



Fisher & Paykel



JET: CG602Q, CG602M, CG902Q, CG902M

TITAN

TITAN: CG901, CG901M

**Gas cooktop
User guide NZ & AU**

Contents

Introducing your cooktop/hob	2
Temperature control	3
Flame Failure safety feature	4
Cookware	5
Cleaning	8
Safety & warnings	10
Frequently asked questions	12
Trouble shooting	13
Warranty	14
Customer care	15
Recipe	16

Important!

It is important that the User Guide should be retained with the appliance for future reference. Should the appliance be sold or transferred to another owner, always ensure that the User Guide is left with the appliance in order that the new owner can familiarise themselves with the appliance and the relevant warnings.

Introducing your cooktop/hob

Now that your new cooktop is installed and ready to use, you will want to know everything about it to ensure excellent results right from the start.

This booklet will introduce you to the features and special talents of your cooktop/hob. We recommend you read the whole book before you start using your cooktop, for the sake of safety as well as success.

First use

- Before using your cooktop clean it with warm soapy water to remove dust.
- Check that the electricity is switched on in order for the electronic ignition to work.

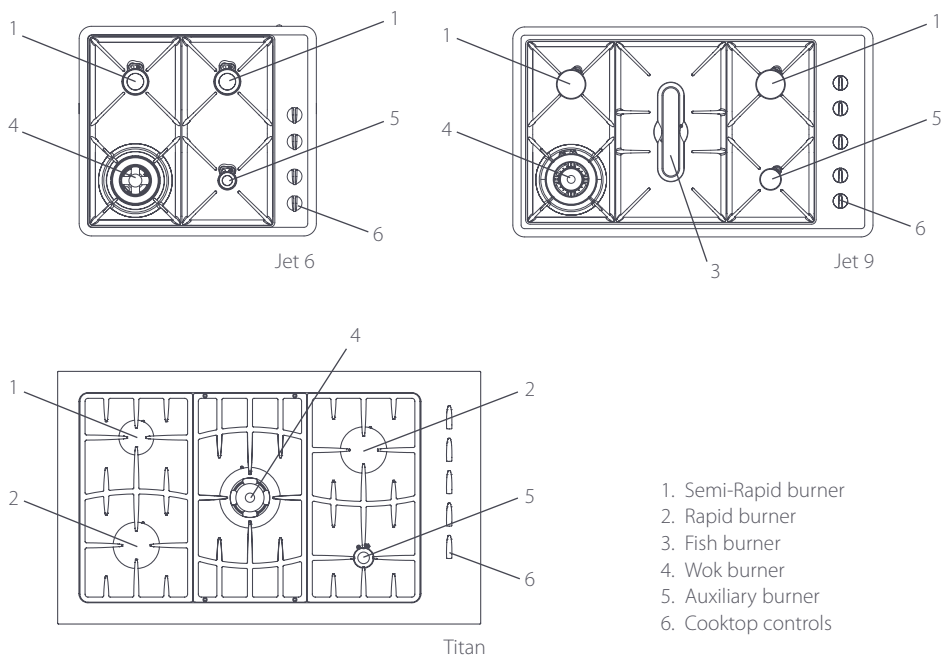

Inspiration

Wrap tasty morsels of oysters, smoked mussels or spicy sausage in strips of bacon. Secure bundles with skewers and lightly fry to serve as nibbles with drinks.

Temperature control

- 1 Choose the control knob for the burner you want to use.
- 2 Press down and turn the knob anti-clockwise all the way to the high flame symbol. Hold down the knob for 5 seconds until the burner lights. All the igniters will spark until the gas ignites on the selected burner.
- 3 The flame can be adjusted anywhere between the high flame symbol and the low flame symbol. Do not regulate the flame between high and off.

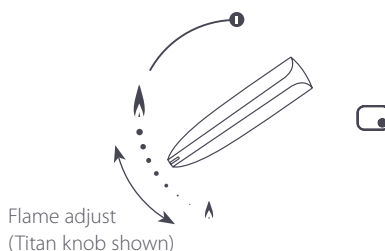

If the cooktop/hob does not light

- Check that you know how the flame failure device works (refer to page 4).
- Check that the power is switched on allowing the electronic ignition to work.
- Check the gas is turned on and coming out.
- Check that the burner rings are placed correctly.
- Clean electrode tips with a toothbrush and methylated spirits.

If the burner has not ignited with 15 seconds, stop operating the igniter and wait at least 1 minute before attempting a further ignition of the burner.

In the event of the burner flames being accidentally extinguished, turn off the burner control and do not attempt to re-ignite the burner for at least 1 minute.

Power failure

In the event of a power failure, the burners can be lit by holding a match close to the side of the burner and turning the control knob to the high flame symbol . Wait until the flame is burning all the way around the burner cap before adjusting.

Heating tips

When you need to boil, simmer or fry your food, first set the temperature to the high flame symbol . Once your pan is boiling, reduce the temperature setting to maintain a steady heat to cook your food through. This will reduce cooking time.

Flame failure safety feature

- Your cooktop has a flame failure safety device fitted.
- A metal probe behind the burner generates electricity when a flame is present.
- After 5 seconds the metal probe gets hot enough to hold a valve open and maintain the gas supply.
- If the flame is blown out then the gas to the burner is cut off.
- To operate the flame failure you need to hold the burner knob down for 5 seconds after the burner has ignited.
- Letting go of the burner knob too soon will extinguish the flame.
- Your cooktop has two probes at the back of the burners, one will be the spark electrode and the other is the flame failure probe.



Inspiration

Make a delicious fruit compote by simmering rhubarb in sugar and water until tender. When cool, add fresh strawberries. Serve chilled.

Cookware

Using a wok

When using a wok on the centre burner, simply turn over the pan support. One side provides a flat surface for flat based pots while the other side has stems specifically designed to support a wok. Care should be taken when using a large wok that other pots are not pushed sideways enough to become unstable or deflect heat onto nearby walls.

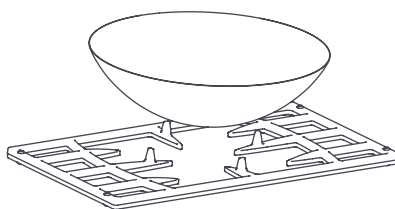

Flip top wok
(Titan models only)

WARNING!

To avoid burns or scalds, do not attempt to handle the pan support while it is hot. Wait until the pan support is cool before turning it over.

Using saucepans

Generally, larger saucepans are more efficient. It is a good idea to match the size of your pan with the cooking zone of the burner and always make sure pans are stable. Do not let large saucepans or frying pans overlap the bench as this can deflect heat onto your benchtop and damage the surface.

Using the simmermat

The Simmermat helps you control the temperature of your cooking surface to ensure the long slow simmering that is needed for successfully cooking delicate foods. Use at low heat only. Always remember it is a simmering utensil and exposure to extreme heat may distort it.

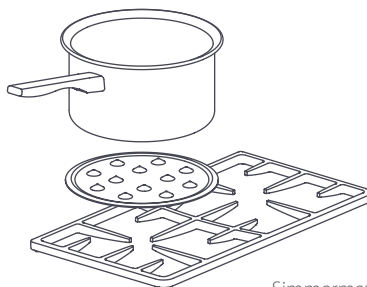

Simmermat

To use the simmermat

- 1 first cook the food, or bring to a boil, over high heat.
- 2 Then reduce the heat and carefully place the Simmermat over the flame with the points facing upward. Put your saucepan on top of the points and simmer on the low flame setting.

WARNING!

Always turn the burner off before moving the Simmermat and handle the hot Simmermat with tongs and/or pot holders to prevent burns.

Using the skillet/griddle (optional extra)

- Your skillet will offer you a quick, hot method of cooking which is ideal for tender cuts of meat, panini, chargrilled vegetables, pikelets and pancakes.
- Best results are obtained by placing the skillet over the large skillet burner on the Jet 9 series gas cooktop or over the left hand burners on the Titan models.
- Always use medium to high temperatures and heat the skillet well before cooking on it. Oil the food with Olive Oil Spray prior to cooking, not the skillet, to avoid splattering and smoking.

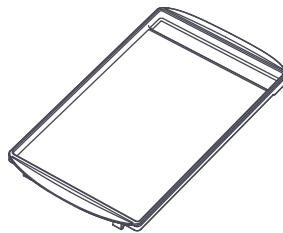

Skillet/griddle first use

- Your new skillet comes with a finish which is intended to burn off with seasoning. The seasoning process will naturally blacken the skillet.
- Wash your skillet thoroughly in warm water with detergent. Use a scouring pad to remove any residue that might be on the skillet. Rinse thoroughly and dry. This may be helped by warming the skillet on a burner.
- Coat the skillet, including handles, liberally with vegetable oil and place in oven at 150°C for 1 hour. Remove from the oven and allow to cool. Wipe excess oil from skillet with a paper towel.

Cleaning your skillet/griddle

Place in hot water with a small amount of detergent while still warm. If there is food residue left on the plate, scrub with a wire barbeque brush to remove it. Make sure that the skillet is completely dry. Do not use abrasive cleaners on your skillet/griddle.

Cooking tips

Skillet cooked steaks are best turned only once about halfway through the cooking time. The skillet needs to have reached a high temperature to prevent the meat stewing in its own juices. Test if steaks are cooked by pressing with tongs, the less movement there is, the more cooked the steak is. Don't cut the steak to see if it is cooked, as this releases the juices and dries the steak out.

Capsicums, eggplant, tomato halves & zucchini are some of the vegetables ideal for char grilling on the ridged side of the skillet, flat breads are wonderful cooked on the flat side.

Hints and tips

To get the best out of your cooktop follow these simple suggestions.

- Do not use an asbestos mat between the flame and the saucepan as this may cause serious damage to your cooktop.
- Never use plastic or aluminium foil dishes on the burners.
- Saucepans should have thick flat bottoms. Food in a saucepan with an uneven bottom will take longer to cook. Heavy saucepans may bend the pan support or deflect the flame.
- Match the bottom of your saucepans with the cooking zone and see that it is stable. This will give you the most efficient cooking. Do not let large saucepans or frying pans overlap the bench as this can deflect heat onto your benchtop and damage the surface.
- For the simmer and semi rapid burners pots should be larger than 12cm in diameter (smaller pots can be used with the coffee pot trivet). The coffee pot support allows small items to be placed on burners. (Jet models only).
- The fish/skillet burner (Jet 9 models only) may be used with pots 18cm in diameter and above. A fish kettle on the fish burner is not only useful for fish, but for steaming long vegetables like cobs of corn, Chinese broccoli, long beans and asparagus.
- The wok burner is primarily designed for woks but may be used with 17- 23cm diameter pots with care. When using a wok only use the circular wok stand supplied with your Jet cooktop.

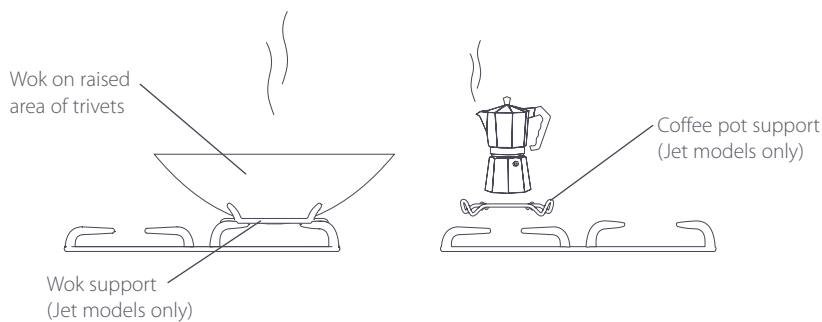

Cleaning

- Apply soapy water with a soft sponge or cloth only when the cooktop is cool.
- Soaking stubborn stains under the soapy cloth for a few minutes will help make them easier to remove.
- Do not use steel soap pads as this may dull the appearance of the appliance over time.
- Pan supports are dishwasher safe.
- The burner parts can be cleaned in hot water, it is important that the holes/slots are kept clear.
- When replacing the burner rings after cleaning, turn the rings until the positioning teeth are placed correctly.
- Clean electrodes with a toothbrush and methylated spirits.

Important!

Do not use harsh/abrasive cleaning agents to clean your cooktop as they may damage the stainless steel finish and the knobs.

Important!

Commercial stainless steel cleaner containing chlorine compounds are corrosive and may damage the appearance of your cooktop.

Brushed stainless steel

- Brushed Stainless Steel can be cleaned with a commercial stainless steel cleaner (see 'Important') or wiped with a clean damp cloth and dried with a lint free cloth.
- Regular use of a stainless steel cleaner will reduce fingerprints and other marks.
- Do not use abrasive cleaners on stainless steel, as they will permanently damage the surface.

Iridium stainless steel (Matt stainless steel)

- This easy clean surface requires only a mild dishwash detergent and warm water.
- Rinse and then dry with a lint free cloth.
- Do not use abrasive cleaners on Iridium as they will permanently damage the surface.

Cleaning the pan supports

- Pan supports are best cleaned immediately after use - before spills get burnt on.
- They are dishwasher safe and can be cleaned with a cream cleaner and a nylon scourer.
- For stubborn stains, soaking in a solution of biological clothes washing detergent for a couple of hours may help.

Repositioning the pan supports

Titan models

The Flip top wok support goes in the centre over the wok burner. The other two pan supports are interchangeable but need to be rotated to match the rounded corners of the base insert.

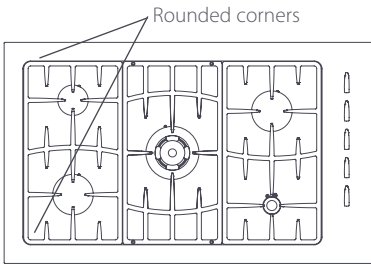

Correct pan support orientation - Titan models

Jet models

The pan supports above the wok burner are different from the other burners. Note the raised area for the wok on the pan support.

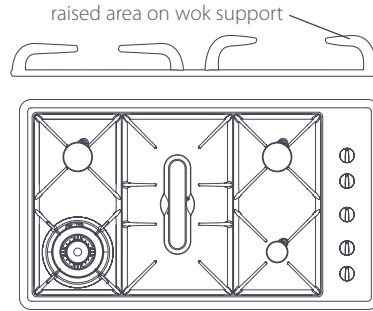

Correct pan support orientation - Jet models

Re-assembling your wok burner (CG901M Iridium models only)

Each part of your wok burner has locating pins to help you to assemble it correctly after cleaning. Incorrect assembly can cause dangerous irregular flames and ignition problems. Refer to this diagram for the correct order of assembly. Note: The brass parts of your wok burner will change colour with use. This is normal and will not affect performance.

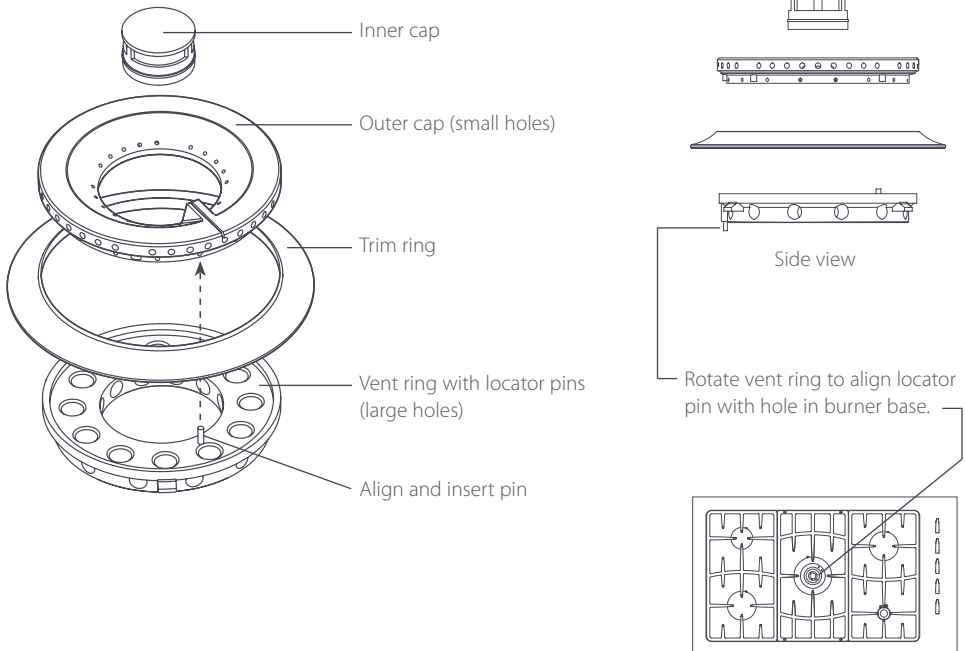

Safety & warnings



WARNING!

Hot Surface Hazard

During use this appliance becomes hot.

Care should be taken to avoid touching cooktop components, burner, pan supports, stainless steel base.

WARNING!

Household appliances are not intended to be played with by children. Children, or persons with a disability which limits their ability to use the appliance, should have a responsible person to instruct them in its use. The instructor should be satisfied that they can use the appliance without danger to themselves or their surroundings.

WARNING!

This appliance should be connected to a circuit that incorporates an isolating switch providing full disconnection from the power supply.

WARNINGS:

- Do not stand or place heavy objects on this appliance.
- Do not use an asbestos mat between the flame and the saucepan as this may cause serious damage to your cooktop.
- Do not place aluminium foil or plastic dishes on the cooktop burners.
- Do not let large saucepans or frying pans overlap the bench as this can deflect heat onto your benchtop and damage the surface.
- Do not spray aerosols in the vicinity of this appliance while it is in operation.
- Do not place aerosol containers near or on the cooktop.
- Do not use a steam cleaner for cleaning this cooktop.

CAUTION!

Handles of saucepans may be hot to touch. Check saucepan handles do not overhang other gas burners that are on. Keep handles out of reach of children.

Electrical supply cord

If the electrical supply cord is damaged, it must only be replaced by an authorised person. Ensure that the electrical connection plug is accessible after installation.

Marine craft & caravan installation

Where this appliance is installed in marine craft or in caravans, it shall not be used as a space heater.

Ventilation

The use of a gas cooking appliance results in the production of heat and moisture in the room in which it is installed. Ensure the kitchen is well ventilated. Keep natural ventilation holes open or install a mechanical ventilation device (mechanical extractor hood).

Prolonged intensive use of the appliance may call for additional ventilation, for example opening of a window, or more effective ventilation, for example increasing the level of mechanical ventilation where present.

Abnormal operation

Abnormal operation which requires the appliance to be serviced include such things as:

- Very yellow flame tips
- Objectionable odours
- The burner flames appearing to lift off the burners



Inspiration

Poach whole pears in white wine, sugar, orange zest, water and a vanilla bean. When tender, serve with whipped cream and caramel sauce.

Frequently asked questions

Q What is the best way to clean stainless steel?

A See cleaning instructions on page 8.

Q How do I clean the pan supports and burners?

A Supports can be washed in the dishwasher or alternatively with a cream cleaner (such as Jif) and a nylon scourer. Burners are best washed in warm water (see cleaning instructions on page 8).

Q All the burners spark at once when I go to light one, is this ok?

A Yes, they are designed to do this.

Q Why doesn't my cooktop light?

A Firstly, check it is plugged in and the gas is turned on. Alternatively, the gas ignitors may be dirty. These are easily cleaned with a toothbrush and methylated spirits. (Also check Trouble shooting on page 13).

Q Will the graphics on my cooktop come off?

A No, these are etched by laser (see stainless steel cleaning instructions, page 8).

Q My burner flames are yellow / slow to start, is something wrong?

A Yes, there are a number of factors which could be causing this

1. If you use bottled gas this may indicate you are getting near the end of the bottle.
2. Your cooktop may not be suited to the gas you are using, check with your service person/installer.
3. The gas pressure may not be at the correct level, check with your service person/installer.
4. See Trouble shooting on page 13.

Q One of my burners has an uneven flame, what can I do?

A Check the burner parts are assembled correctly (see pages 9).

Q What size pots should I use?

A Generally larger pots are more energy efficient, see page 5 for further details.

Q Do I need special pans for a gas cooktop?

A Regular pans are fine. We recommend thick based pans for efficient, even heat.

Trouble shooting

Problem	Possible solutions
My cooktop does not light	<p>Check it is plugged in and there is power to the wall socket.</p> <p>The gas igniters may be dirty. These can be easily cleaned with a toothbrush and methylated spirits.</p> <p>The burner parts may not be located properly. Check the assembly and make sure the burner cap is sitting flat.</p> <p>Check the gas supply valve is turned on and the supply to the house is working. Gas should be heard when you turn a burner on.</p>
My burner flames are yellow/slow to start	<p>The burner parts may not be located properly. Check the assembly and make sure the burner cap is sitting flat.</p> <p>If you use bottled gas this may indicate you are getting near the end of the bottle.</p> <p>Check that the burner parts are not blocked with water.</p> <p>The gas pressure may not be at the correct level, check with your service person/installer.</p>
One of my burners has an uneven flame	<p>Check the burner parts are assembled correctly and that the burner cap is sitting flat on the burner.</p>
My cooktop goes out when I let go of the knob	<p>Your cooktop has a safety feature called 'flame failure'. When lighting a burner, it is necessary to hold down the knob for 5 seconds until it is properly engaged. See page 5 for more on flame failure.</p>
The flame goes out at low settings	<p>Gas supply pressure may be low, check with service person/installer.</p> <p>Low setting may have been adjusted incorrectly, check with your service person/installer.</p>

Warranty

When you purchase any new Fisher & Paykel whiteware Product you automatically receive a 2 year Manufacturer's Warranty covering parts and labour for servicing.

Fisher & Paykel undertakes to

Repair or, at its option, replace without cost to the owner either for material or labour any part of the Product, the serial number of which appears on the Product, which is found to be defective within TWO YEARS of the date of purchase.

This warranty DOES NOT cover

- A. Service calls to which are not related to any defect in the Product. The cost of a service call will be charged if the problem is not found to be a Product fault. For example:
 - 1. Correct the installation of the product.
 - 2. Instruct you how to use the product.
 - 3. Replace house fuses or correct house wiring or plumbing.
 - 4. Correcting fault(s) caused by the user.
- B. Defects caused by factors other than:
 - 1. Normal domestic use or
 - 2. Use in accordance with the Product's User Guide.
- C. Defects to the Product caused by accident, neglect, misuse or Act of God.
- D. The cost of repairs carried out by non-authorized repairers or the cost of correcting such unauthorised repairs.
- E. Normal recommended maintenance as set out in the Product's User Guide.
- F. Repairs when the appliance has been dismantled, repaired or serviced by other than a Fisher & Paykel Authorised Customer Service Centre or the selling dealer.
- G. Pick up and delivery.
- H. Transportation or travelling costs involved in the repair when the product is installed outside the Fisher & Paykel Authorised Customer Service Centre's normal service area.

Service under this Manufacturer's Warranty must be provided by an Authorised Service Centre, please refer to the Customer care section for contact details. Such service shall be provided during normal business hours. This warranty certificate should be shown when making any claim.

Note: This Warranty is an extra benefit and does not affect your legal rights.

Please keep this User Guide in a safe place.
Do not return to Fisher & Paykel.

Customer care

Before you call for service or assistance ...

Check the things you can do yourself. Refer to your User Guide and check...

- 1 Your product is correctly installed
- 2 You are familiar with its normal operation

If after checking these points you still need assistance, please refer to the following or contact us through our website:

www.fisherpaykel.com

In New Zealand if you need assistance ...*

Call your Fisher & Paykel retailer who is trained to provide information on your product, or if we can be of any further help, please contact our Customer Care Centre,

Toll Free: 0800 FP CARE or 0800 37 2273

Fax: (09) 273 0656

Email: customer.care@fp.co.nz

Postal Address: PO Box 58732, Greenmount, Auckland.

If you need service ...*

Fisher & Paykel has a network of independent Fisher & Paykel Authorised Service Centres whose fully trained technicians can carry out any service necessary on your product. Your dealer or our Customer Care Centre can recommend an Authorised Service Centre in your area.

In Australia if you need assistance ...*

Call the Fisher & Paykel Customer Care Centre and talk to one of our consultants.

Toll Free: 1300 650 590 from anywhere within Australia

Fax: (07) 3826 9298

Email: customer.care@fp.com.au

Postal Address: PO Box 798 Cleveland, QLD 4163.

If you need service ...*

Fisher & Paykel Australia Pty Ltd has a network of independent Fisher & Paykel Authorised Service Centres whose fully trained technicians can carry out any service necessary on your product. Your State Office or our Customer Care Centre can recommend an Authorised Service Centre in your area.

* If you call or write, please provide: name, address, model number, serial number, date of purchase and a complete description of the problem. This information is needed in order to better respond to your request for assistance.

Recipe

Beef bourginon (Serves 2 - 4)

The Simmermat is perfect for stews and soups. Long slow cooking at a gentle simmer gives meat dishes that are tender and full of flavour. Try this variation on a French classic.

450g chuck or stewing steak, cubed
4 tbsp oil
200g tiny onions or 2 large onions, chopped
200g carrot, peeled and cut into large slices
2 tbsp oil
4 cloves of garlic, crushed
4 tbsp flour
2 cups good red wine
2 cups beef stock
2 bay leaf
2 tsp thyme

- 1 Place beef in a bowl and sprinkle with salt and pepper. Toss.
- 2 Heat 2 tbsp of the oil in a medium sized saucepan on high. Add half of the steak cubes and brown quickly turning with a wooden spoon to sear all the sides. This is an excellent way to give stews great flavour and a rich brown colour. It should only take a couple of minutes but the meat may spit so take care.
- 3 Remove the first batch and repeat with the remaining steak and two more tablespoons of oil.
- 4 Add onions, carrot and the last 2 tbsp of oil to the empty pan and cook on medium flame until beginning to brown.
- 5 Add garlic and flour and cook until lightly coloured, stirring constantly.
- 6 Stir in the wine and stock, then add bay leaves, thyme and steak. Bring to the boil.
- 7 Reduce the flame to low and carefully place the Simmermat over the flame with the points facing upward. Put the pan on the mat and a lid on the pan and simmer for an hour or two; until the meat is tender and the liquid is full of flavour.
- 8 Serve with creamy mashed potatoes and garnish with lots of chopped fresh parsley.

Copyright Reserved © Fisher & Paykel 2003.

The product specifications in this booklet apply to the specific products and models described at the date of issue. Under our policy of continuous product improvement, these specifications may change at any time. You should therefore check with your Dealer to ensure this booklet correctly describes the product currently available.

www.fisherpaykel.com

NZ AU

Gas cooktop user guide

Published: 12/2003

Part No. 531927 A