



Important!

SAVE THESE INSTRUCTIONS

The models shown in this document may not be available in all markets and are subject to change at any time. For current details about model and specification availability in your country, please visit our local website listed at the end of this document or contact your local Fisher & Paykel dealer.

① SAFETY AND WARNINGS

⚠ WARNING!	
	Electrical shock hazard Disconnect appliance from main power supply before continuing. Failure to do so could result in electrical shock or death.
⚠ WARNING!	
	Cut hazard Take care - panel edges are sharp. Failure to use caution could result in injury or cuts.

Important safety precautions!

- Particular attention shall be given to the relevant requirements regarding ventilation.
- Please make this information available to the person installing the appliance as it could reduce your installation costs.
- This appliance is to be installed and connected to the electricity and gas supply only by an authorised person.
- Installation must comply with your local building and local gas authority codes and electricity regulations.
- Failure to install the appliance correctly could invalidate any warranty or liability claims.
- These appliances are registered in: (New Zealand) at www.ess.govt.nz and (Australia) with SAI Global at www.saiglobal.com.
- This gas appliance is suitable for connection to natural gas only. If in doubt, refer to the local gas network operator or gas supplier to confirm gas type at installation site.

Before you install the appliance, please make sure that

- the local distribution conditions (nature of gas and pressure) and the adjustment of the appliance are compatible. For adjustment conditions for this appliance, see 'Gas rate summary'
- a suitable disconnection switch is incorporated in the permanent wiring, mounted and positioned to comply with the local wiring rules and regulations. A means of disconnection with at least a 3 mm air gap contact separation in all poles must be incorporated into the fixed wiring in accordance with the wiring rules, unless the local wiring rules allow for alternative means
- the appliance is connected to a 220V - 240V 50Hz (10 A) power supply only and earthed via the power supply cable
- there is a power outlet within reach of the power supply cable (900 mm from the centre rear of the product). This must be accessible after installation. The power supply cable should not touch any metal parts
- if the power supply cable is damaged, it is replaced only by the special cable: Part no. 531953 - Flex Terminal Block Assy NZ/AU, obtainable from authorised Fisher & Paykel Service Agents
- the supply connection point (gas shut-off valve) is accessible after installation
- the benchtop is made of a heat resistant material
- the installation complies with all the requirements of Australian and New Zealand Gas Installation Standards (AS5601, NZS5261), including that the product has to be installed so that the surface temperature of any nearby combustible surface will not exceed 65 °C above ambient. See ③ 'Clearance Dimensions'.

When you install the appliance

- We **do not recommend** you flush mount or seal this appliance into the bench with silicone or glue. Doing so will make future servicing difficult. Fisher & Paykel will not be liable for any costs associated with removing or replacing a sealed-in appliance, nor for repairing any damage that may be incurred by doing this.
- Seal exposed bare edges of the cutout with an oil-based paint or moisture-proof polyurethane to prevent possible moisture creeping between the cooktop trim and the benchtop.
- We **do not recommend** the use of a down-draught extractor fan with the appliance, as it may distort the flame pattern, causing uneven heating and reduced cooking performance.
- Where this appliance is installed in marine craft or in caravans, it shall not be used as a space heater.
- No combustible material or products should be placed on this appliance at any time.
- Do not spray aerosols in the vicinity of this appliance while it is in operation.
- If, after following the instructions given, the appliance cannot be adjusted to perform correctly, please refer to the Service & Warranty book for warranty details and your nearest Authorised Service Centre, Customer Care, or contact us through our website: www.fisherpaykel.com.

② PRODUCT & CABINETY DIMENSIONS

Note: Gas inlet connection is located in the back left corner.

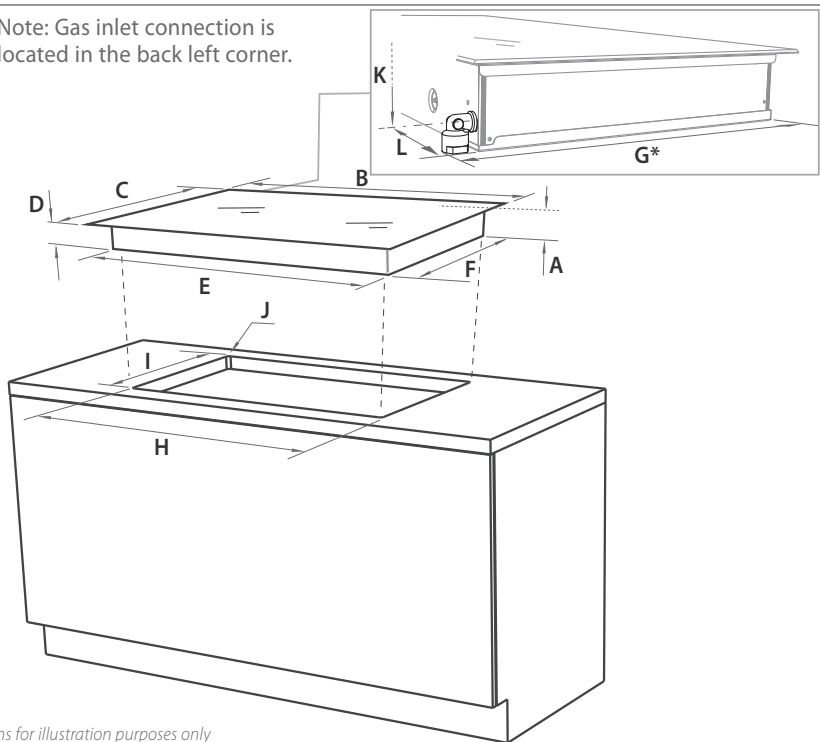

Installation diagrams for illustration purposes only

Product and cabinetry dimensions (mm)

	CG903ML IZONA	CG903MLD IZONA DEEP
A	96	96
B	900	900
C	410	530
D	89	89
E	856	856
F	384	480
G	424	480
H	865	865
I	390	494
J	max. 10	max. 10
K	64	64
L	20	20

Note: *(CG903ML models only) If benchtop thickness exceeds 50 mm, additional cutout space will be required to accommodate the fitted elbow.

③ CLEARANCE DIMENSIONS

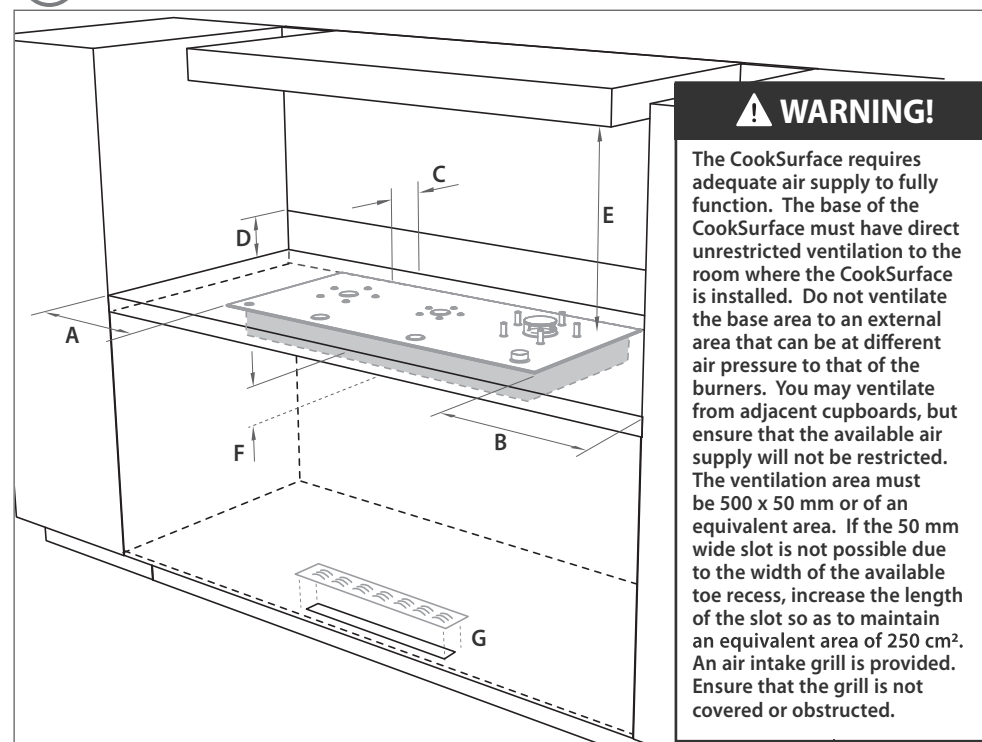

⚠ WARNING!

The CookSurface requires adequate air supply to fully function. The base of the CookSurface must have direct unrestricted ventilation to the room where the CookSurface is installed. Do not ventilate the base area to an external area that can be at different air pressure to that of the burners. You may ventilate from adjacent cupboards, but ensure that the available air supply will not be restricted. The ventilation area must be 500 x 50 mm or of an equivalent area. If the 50 mm wide slot is not possible due to the width of the available toe recess, increase the length of the slot so as to maintain an equivalent area of 250 cm². An air intake grill is provided. Ensure that the grill is not covered or obstructed.

Clearances (mm)

	CG903ML IZONA	CG903MLD IZONA DEEP
A	60	60
B	80	80
C	100	10
	10	10
D	150	150
E	650	650
	800	800
	650	650
	500	500
F	115	115
	100	100
G	cutout measuring 50 x 50 mm for air intake grill. Ensure air can easily enter the area around the base of the product from the room in which the product is installed	

Note: Ensure there is an earthed power outlet within 900 mm of the centre rear of the product. The supplied flexible hose must be used between the product gas inlet and the connector on the wall which should be 650 - 750 mm above the floor and towards the left-hand end of the product. It should be accessible with the product installed.

④ PARTS SUPPLIED

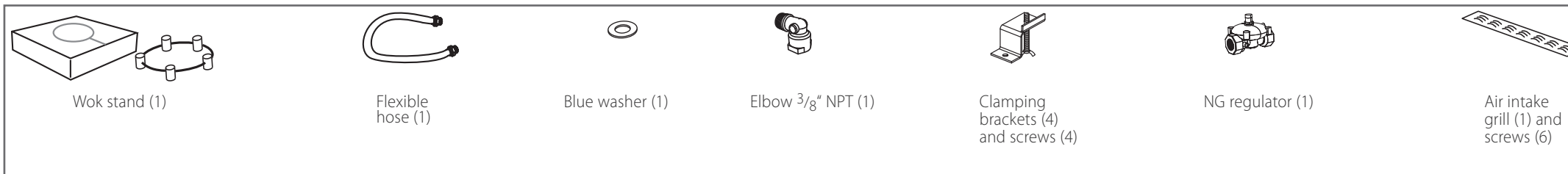

⑤ GAS RATE SUMMARY

All appliances are factory set for natural gas and are not currently convertible to LPG.

NZ AU	Injector orifice (mm) Nominal rating (MJ/h)		Injector orifice (mm) Nominal rating (MJ/h)		Injector orifice (mm) Nominal rating (MJ/h)	
	SMALL		MEDIUM		WOK	
NG (1.0 kPa)*	NG		NG		NG	
CG903ML & CG903MLD	1.09Y	7.2	1.15Y	8.0	1.65	12.8

*Nominal pressure with the two smaller burners on High.

⑥ FLUSH MOUNTING INSTALLATION (NOT RECOMMENDED)

⚠ WARNING!

We do not recommend flush mounting and sealing as servicing requires the CookSurface to be removed from the benchtop. The owner carries all risk for flush mounting the CookSurface. The owner must ensure the CookSurface has been cut out from the benchtop before servicing can be carried out. Fisher & Paykel will not be liable for any costs associated with removing or replacing a flush-mounted and/or sealed-in product, nor for repairing any damage that may be incurred by doing this.

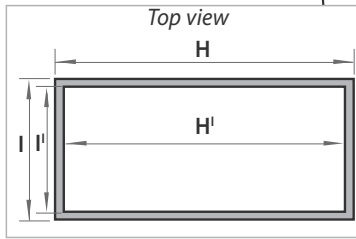
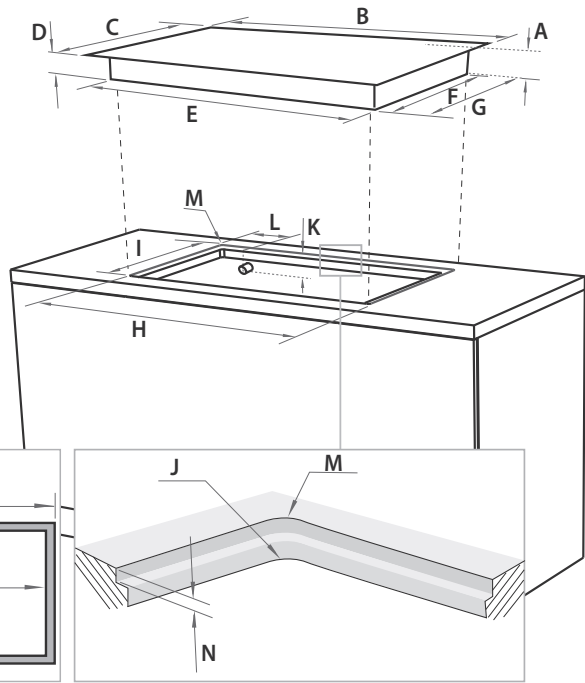

Product and cabinetry dimensions (mm)

	GG903ML IZONA	GG903MLD IZONA DEEP
A	96	96
B	900	900
C	410	530
D	94	94
E	856	856
F	384	480
G	424	480
H	905	905
H'	865	865
I	415	535
I'	390	494
J	max. 10	max. 10
K	64	64
L	20	20
M	max. 2	max. 2
N	5	5

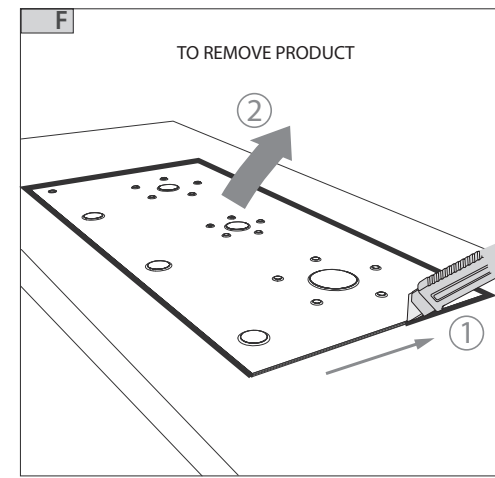
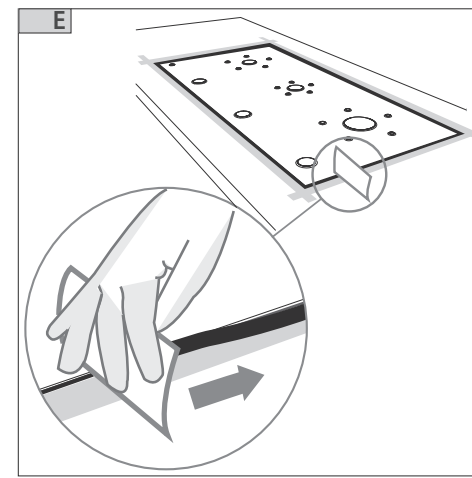
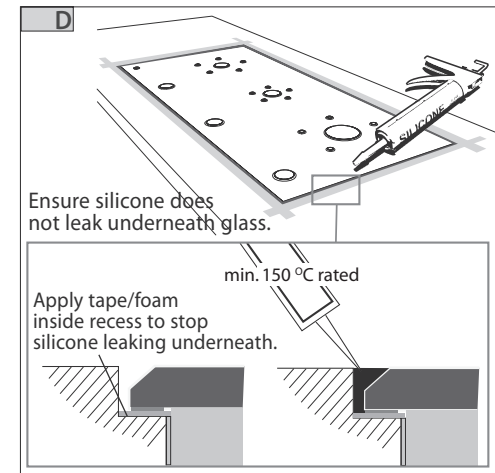
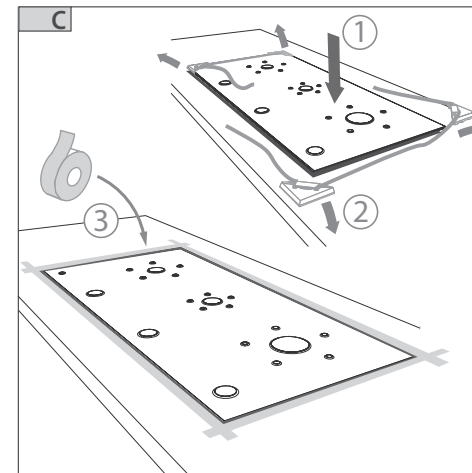
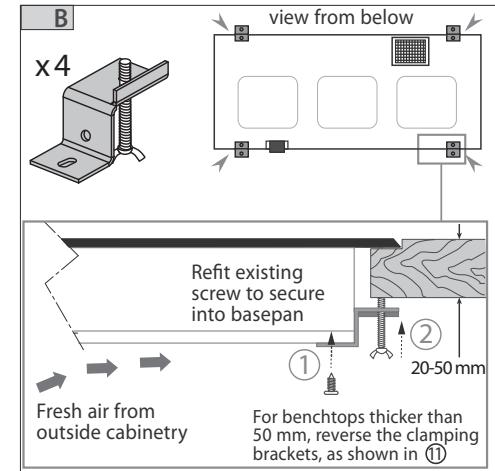
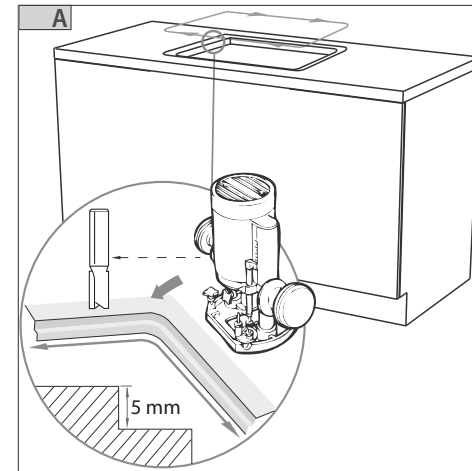

⑦ REMOVE FROM PACKAGING

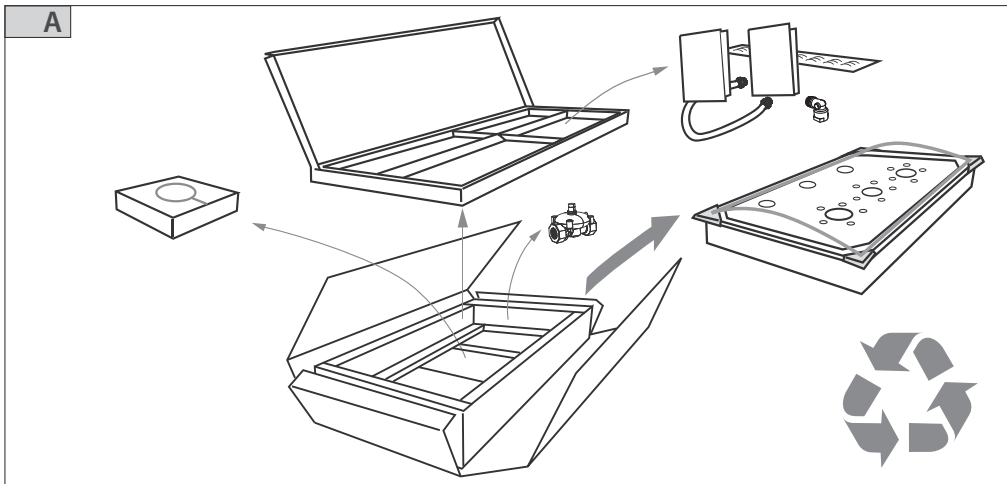

⑧ ENSURE THERE IS ADEQUATE AIR SUPPLY

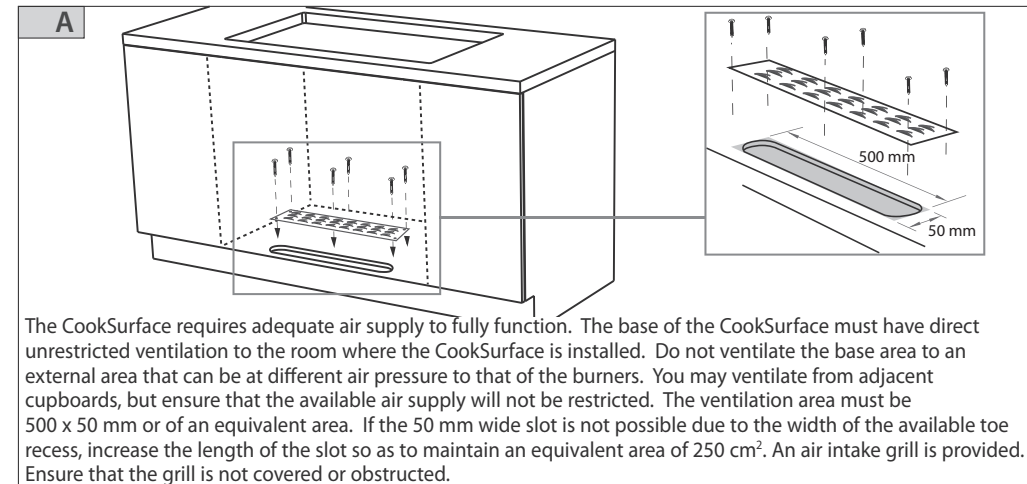

⑨ FIT THE ELBOW & FLEXIBLE HOSE

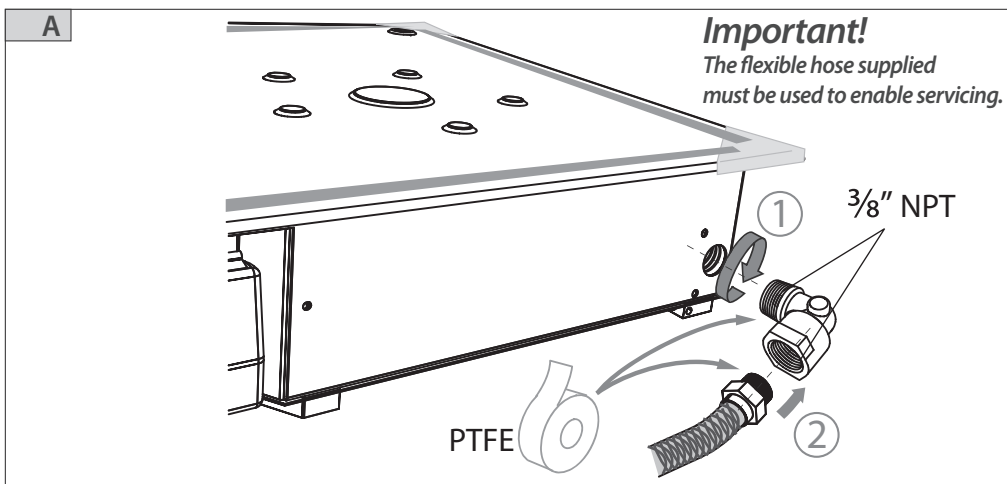

⑩ LOWER GENTLY INTO THE CUTOUT

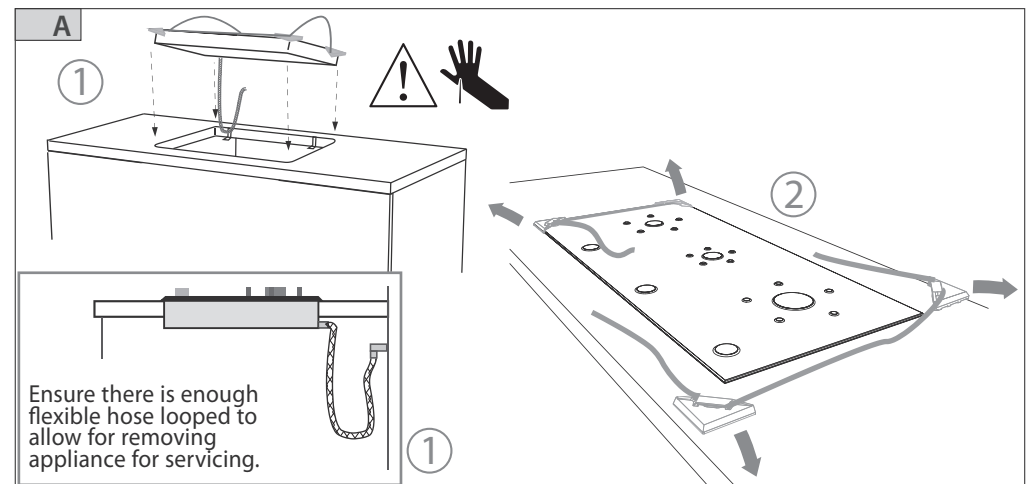

⑪ SECURE THE PRODUCT TO THE BENCHTOP

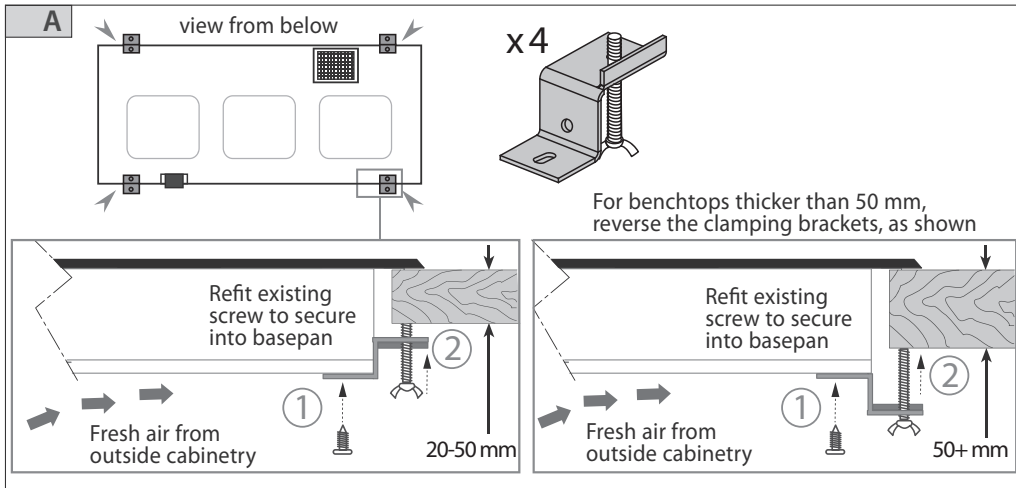

⑫ CONNECT TO THE GAS & ELECTRICAL SUPPLY

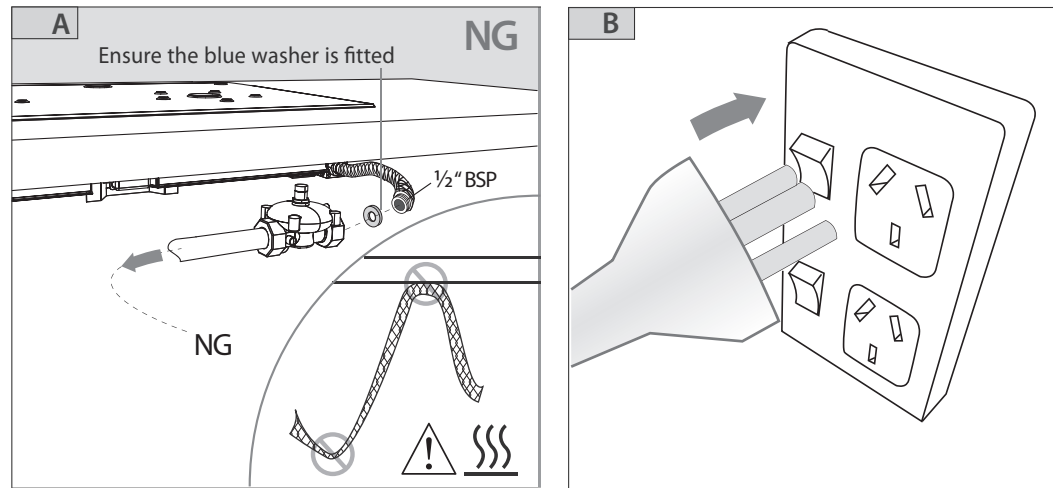

⑬ CHECK FOR GAS LEAKS

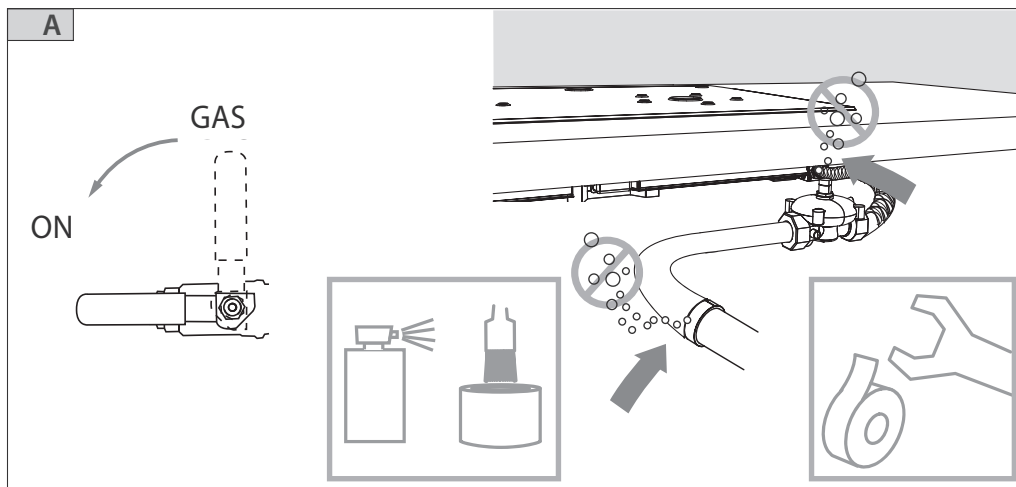

⑭ TEST OPERATION

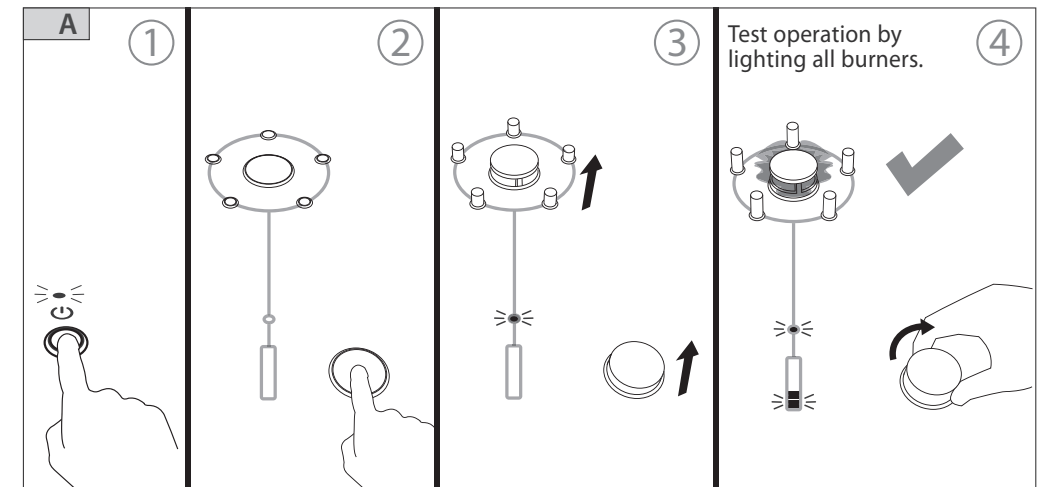

15 FINAL CHECKLIST

TO BE COMPLETED BY THE INSTALLER



- Have you installed the clamping brackets?
- Have you allowed for adequate air supply to the product?
- Have you used the supplied flexible hose and blue washer?
- Have you leak-tested all connections?
- Is the regulator set to the correct working pressure?
- Have you placed the supplied duplicate data plate on an adjacent surface?
- Is the CookSurface earthed?
- Check that the power supply cable is NOT touching the CookSurface.

OPERATION:

- Do all burners ignite both individually and in combination?
- Are the flames consistent and appropriately sized?
- Have you demonstrated the basic operation to the customer?

Installer's name: _____

Installer's signature: _____

Installation company: _____

Date of installation: _____

LEAVE THESE INSTRUCTIONS WITH THE CUSTOMER