

Installation instructions and User guide

Gas cooktops

CG604 models

NZ AU

Safety and warnings	2
Installation instructions	6
Introduction	16
Using your cooktop	18
Care and cleaning	22
Troubleshooting	26
Warranty and service	27

Important!

SAVE THESE INSTRUCTIONS

The models shown in this user guide may not be available in all markets and are subject to change at any time. For current details about model and specification availability in your country, please visit our local website listed on the back cover or contact your local Fisher & Paykel dealer.

! WARNING!



Cut Hazard

Beware of sharp edges when handling stainless steel appliances.
Failure to use caution could result in injury or cuts.

! WARNING!



Electrical Shock Hazard

Before carrying out any work on the electrical section of the appliance, it must be disconnected from the mains electricity supply.
Connection to a good earth wiring system is absolutely essential and mandatory.
Failure to follow this advice may result in death or electrical shock.

Important safety instructions

Installation

- *Read these instructions carefully before installing or using this product.*
- *Please make this information available to the person responsible for installing the product as it could reduce your installation costs.*
- *This appliance shall only be installed and serviced by an authorised person.*
- *Incorrect installation, for which the manufacturer accepts no responsibility, may cause personal injury or damage.*
- *These products are registered:
in New Zealand at www.ess.govt.nz
in Australia with AGA at www.gas.asn.au.*
- *This appliance must be installed in accordance with these installation instructions, local gas fitting regulations, municipal building codes, water supply regulations, electrical wiring regulations, AS5601 / AG 601 and NZS5261 - Gas Installations and any other relevant statutory regulations.*
- *Do not modify this appliance.*
- *Models without flame failure safety feature **MUST NOT** be installed in marine craft, caravans or mobile homes.*
- *Always disconnect the cooktop from the electricity supply before carrying out any maintenance operations or repairs.*
- *In the room where the cooktop is installed, there must be enough air to allow the gas to burn correctly, according to the current local regulations.*

- *Particular attention shall be given to the relevant requirements regarding ventilation.*
- *This product should not be sealed into the bench with silicone or glue. Doing so will make future servicing difficult. Fisher & Paykel will not be liable for costs associated with releasing such a product, nor for repairing damage that may be incurred in doing this.*
- *When this product is installed it shall not be used as a space heater, especially if installed in boats or caravans.*
- *No combustible material or products should be placed on this product at any time.*
- *Do not spray aerosols in the vicinity of this product while it is in operation.*

⚠ WARNING!**Hot Surface Hazard**

This appliance becomes hot during use.

Do not touch the cooktop components, burners, trivets, pan supports or the base when hot.

Before cleaning, turn the burners off and make sure the whole cooktop is cool.

Failure to follow this advice may result in serious injury.

⚠ WARNING!**Explosion Hazard**

Do not use or store flammable materials such as gasoline near this appliance. Do not spray aerosols in the vicinity of this appliance while it is in operation.

Failure to follow this advice may result in death or serious injury.

⚠ WARNING!**Electrical Shock Hazard**

Switch off the cooktop at the wall before carrying out cleaning or maintenance.

Failure to follow this advice may result in death or electrical shock.

Important safety instructions

Operation

- *Keep children away from the cooktop when it is in use.*
- *Household appliances are not intended to be played with by children.*
- *Children, or persons with a disability which limits their ability to use the appliance, should have a responsible person to instruct them in its use. The instructor should be satisfied that they can use the appliance without danger to themselves or their surroundings.*
- *If the electrical supply cord is damaged, it must only be replaced by an authorised person. Ensure that the electrical connection plug is accessible after installation.*
- *This appliance should be connected to a circuit that incorporates an isolating switch providing full disconnection from the electricity supply.*
- *Do not use an asbestos mat or decorative covers between the flame and the saucepan as this may cause serious damage to your cooktop.*
- *Do not place aluminium foil or plastic dishes on the cooktop burners.*
- *Do not let large saucepans or frying pans overlap the bench as this can deflect heat onto your benchtop and damage the surface.*
- *Do not let large saucepans, frying pans or woks push any other pans aside. This could make them unstable or deflect heat onto your benchtop and damage the surface.*
- *Do not use a steam cleaner for cleaning this cooktop.*
- *Saucepan handles may be hot to touch. Ensure saucepan handles do not overhang other gas burners that are on. Keep handles out of reach of children.*
- *Do not stand or place heavy objects on this appliance.*
- *After use, ensure that the knobs are in 'OFF' position.*
- *This appliance shall not be used as a space heater, especially if installed in marine craft or caravans.*
- *The use of a gas cooking appliance results in the production of heat and moisture in the room in which it is installed. Ensure the kitchen is well ventilated. Keep natural ventilation holes open or install a mechanical ventilation device (mechanical extractor hood). Prolonged intensive use of the appliance may call for additional ventilation, for example opening of a window, or more effective ventilation, for example increasing the level of mechanical ventilation where present.*
- *After having unpacked the appliance, check to ensure that it is not damaged. In case of doubt, do not use it and consult your supplier or a professionally qualified technician. Packing elements (i.e. plastic bags, polystyrene foam, nails, packing straps, etc.) should not be left around within easy reach of children, as these may cause serious injuries.*
- *Some appliances are supplied with a protective film on steel and aluminium parts. This film must be removed before using the appliance.*

6 Installation instructions

Dimensions and clearances

This cooktop has been designed and constructed in accordance with the following codes and specifications:

AGA101 (AS 4551) Approval Requirements for Domestic Gas cooking appliances

AS/NZS 60335-1 General Requirements for Domestic electrical appliances

AS/NZS 60335-2-6 Particular Requirements for Domestic electrical cooking appliances

AS/NZS 1044 Electromagnetic Compatibility Requirements.

The installation shall comply with the dimensions in Figs. 1 and 2, bearing in mind the following requirements:

- A minimum clearance of 20 mm has to be kept between the base of the cooktop and the top of an underbench appliance or a shelf. To ensure this clearance, mount the spacers supplied with the appliance, as shown in Fig. 3.
- **Overhead clearances** - In no case shall the clearance between the highest part of the cooktop and a range hood be less than 600 mm, or for an overhead exhaust fan, 750 mm. Any other downward-facing combustible surface less than 600 mm above the highest part of the cooktop shall be protected for the full width and depth of the cooking surface area in accordance with local regulations in force. However, in no case shall this clearance to any surface be less than 450 mm.
- **Side clearances** - Where the distance from the periphery of the nearest burner to any vertical combustible surface is less than 200 mm, the surface shall be protected in accordance with local regulations in force to a height of not less than 150 mm above the cooktop for the full dimension (width or depth) of the cooking surface area.
- Where the distance from the periphery of the nearest burner to any horizontal combustible surface is less than 200 mm, the horizontal surface shall be more than 10 mm below the surface of the cooktop, or the horizontal surface shall be above the trivets (see requirement for vertical combustible surfaces above).
- **Protection of combustible surfaces** - Local regulations in force specify that, where required, protection shall ensure that the surface temperature of the combustible surfaces does not exceed 65 °C above ambient. To comply with this requirement satisfactorily, fix 5 mm-thick ceramic tiles to the surface or attach fire-resistant material to the surface and cover with sheet metal (minimum thickness 0.4 mm).

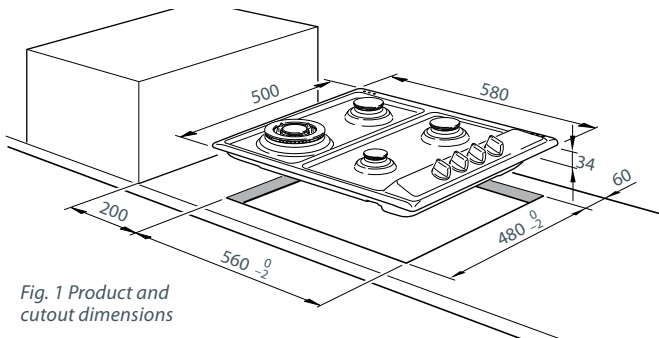

Fig. 1 Product and cutout dimensions

- Installation clearances and protection of combustable surfaces shall comply with the current local regulations e.g. AG 601 (AS 5601) and NZS5261 - Gas Installations code.

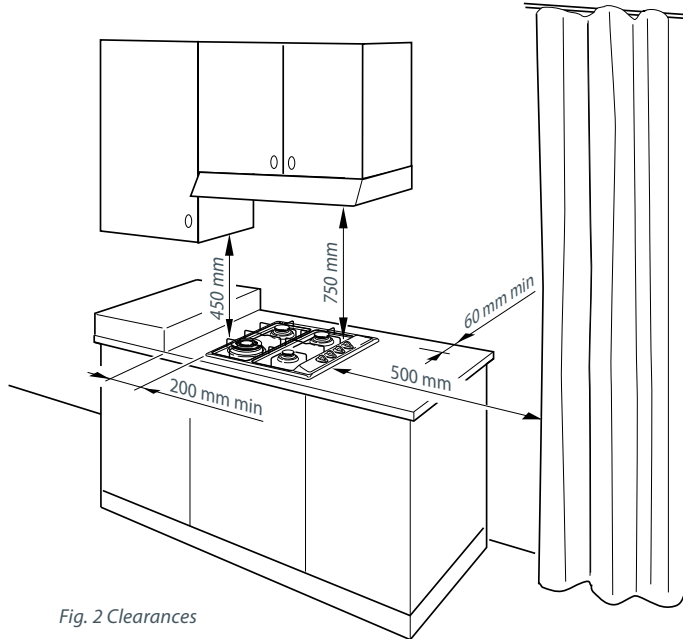

Fig. 2 Clearances

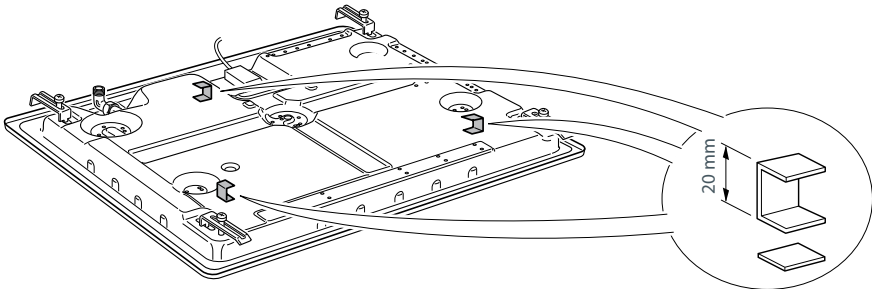

Fig. 3 Mounting the base clearance spacers

Fastening the installation brackets (Fig. 4)

Each cooktop is provided with an installation kit including brackets and screws for fastening the cooktop to benches from 20 to 40 mm thick.

- Turn the cooktop upside down, place it on a soft surface and fasten the brackets "F" and "R" to the appropriate socket holes, without tightening the screws "B" for the moment (see Fig. 4).

Fastening the cooktop (Fig. 4)

- Spread the sealing material "C" out along the edge of the cutout, making sure that the junctions overlap at the corners.
- Insert the cooktop into the cutout and position it correctly.
- Adjust the position of the brackets "F" and "R" and tighten screws "B" to secure the cooktop firmly in position.
- Using a sharp cutter or trimmer knife, trim the excess sealing material around the edge of the cooktop. Take care not to damage the workbench.

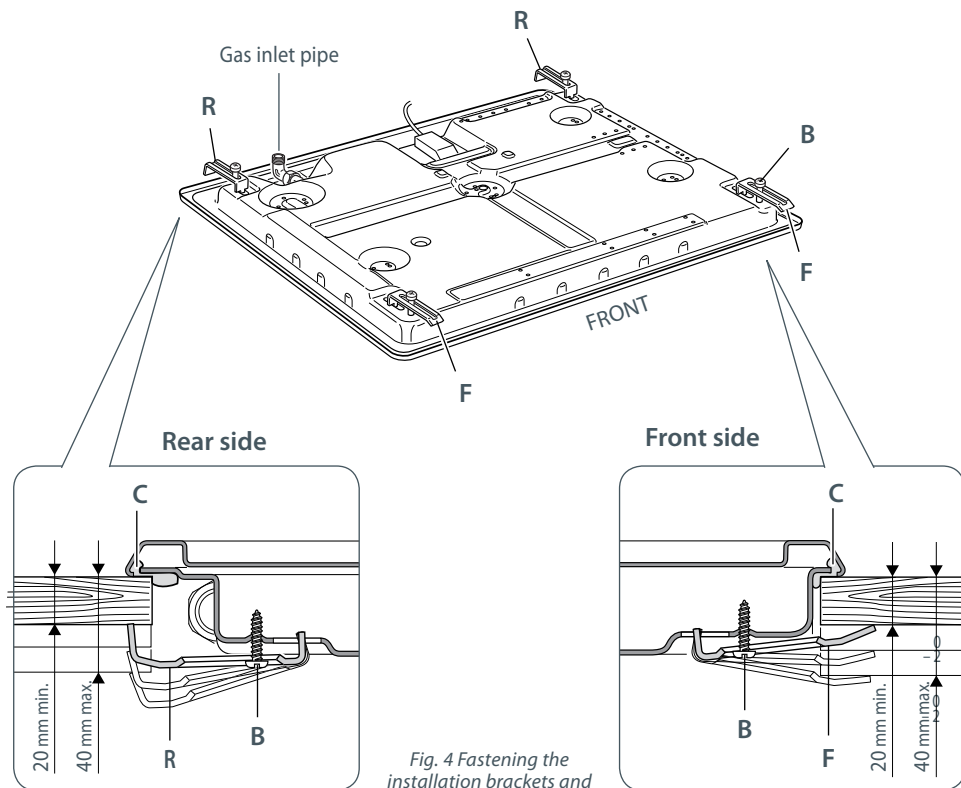

Fig. 4 Fastening the installation brackets and the cooktop

Connecting the cooktop to the gas supply

- The gas connection must be carried out by an authorised person according to the relevant standards.
- Before connecting the appliance to the gas main, mount the brass conical adaptor onto the gas inlet pipe, upon which the washer has been placed (Figs. 5 and 6). Conical adaptor and washer are supplied with the appliance (packed with conversion kit for use with Natural gas or LPG).
- This appliance is suitable for use with Natural gas or LPG. (Check the “gas type” sticker attached to the appliance).
- For Natural Gas, connect the gas supply to the gas pressure regulator which is supplied with the appliance (Fig. 5). Adjust the regulator to obtain a test point pressure of 1 kPa with the two semi-rapid burners operating at the maximum.
- For LPG, connect the gas supply to the test point adaptor which is supplied with the appliance (Fig. 6). Ensure that the supply pressure is regulated to 2.75 kPa.
- Do NOT force the “elbow” to rotate before loosening the floating nut.
- Do NOT overtighten the floating nut at the “elbow”.

Gas connection for NATURAL GAS

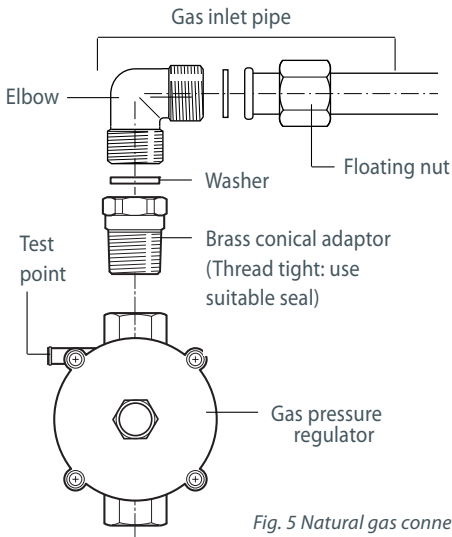

Fig. 5 Natural gas connection

Gas connection for LPG

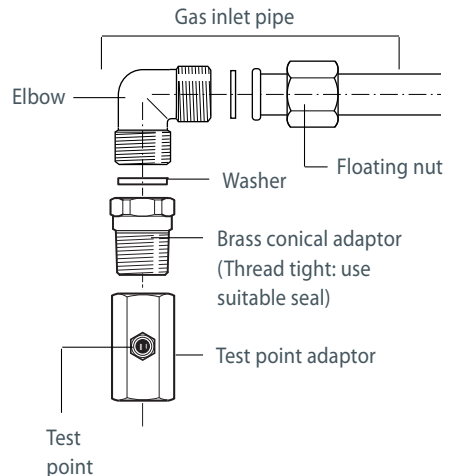

Fig. 6 LPG connection

Leak-testing and flame-testing the cooktop

- 1 After connecting the gas supply, check the piping and connections for leaks using a soap and water solution. The presence of bubbles indicates a leak. Tighten or replace connections as appropriate.

Important!

Do not use any naked flame to check for leaks.

- 2 The operation of the appliance MUST be tested before leaving.
- 3 Adjust the test point pressure or supply pressure to the value which is appropriate for the gas type.
- 4 Turn on the appliance gas controls and light each burner. Check for a well defined blue flame without any yellow tipping. If any abnormality is evident, check that the burner cap is located properly and the injector nipple is aligned correctly.
- 5 Check the minimum burner setting by quickly rotating the gas control knob from the maximum to the minimum position. The flame must not go out. If adjustment is required, see 'Adjusting the minimum burner setting' section following.
- 6 If satisfactory performance cannot be obtained, the installer shall check the installation and notify the local gas supply authority about a gas supply problem, or if it is an appliance problem, our Customer Service Centre should be called to obtain the nearest authorised Service Agent.
- 7 Where the appliance data plate cannot be easily read with the appliance installed, the duplicate data plate must be attached to an adjacent surface and the duplicate Natural gas or LPG conversion label should also be included where a Natural gas or LPG conversion has been completed.

Installation with a flexible hose assembly

- If this appliance has to be installed with a hose assembly, the installer must refer to the network operator or gas supplier for confirmation of the gas type, if in doubt.
- When used with a flexible hose, the connector on the wall should be between 800 mm to 850 mm above the floor and in the region outside the width of the appliance to a distance of 250 mm. The supply connection point shall be accessible with the appliance installed.
- Flexible hose assemblies should be AS/NZS 1869 Class B or Class D certified. The thread connection shall be Rp 1/2" (ISO 7-1) male.
- The hose assembly must be as short as practicable and comply with relevant AS 5601/NZS 5261 requirements.

Important!

- *After connection, the installer must check that the hose is not kinked, subjected to abrasion or permanently deformed. The installer must check also that the hose is not near (or in contact) with any hot surfaces eg. base of metal hotplate, underbench oven etc.*
- *The installer shall ensure the hose assembly is restrained from accidental contact with the flue outlet of an underbench oven.*

Table for the choice of injectors

	Natural Gas		LPG	
Test point Pressure [kPa]	1.0		2.75	
BURNER	Injector Orifice Dia. [mm]	Gas Consumption [MJ/h]	Injector Orifice Dia. [mm]	Gas Consumption [MJ/h]
Auxiliary	0.85	3.60	0.53	3.60
Semi-rapid	1.12	6.30	0.70	6.30
Rapid	1.45	10.30	0.91	10.80
Triple-ring wok	1.60	12.70	0.95	11.90

Converting to a different gas type

Important!

The conversion procedure must be carried out only by an authorised person.

This appliance is suitable for use with Natural gas or LPG (check the “gas type” sticker attached to the appliance). To convert from one gas type to another, you need to replace the injectors, and then adjust the minimum burner setting.

Replacing the injectors

- Remove the trivets and burners from the cooktop.
- Using a spanner, remove the injector (Figs. 7 and 8) and replace it with one according to the gas type (see ‘Table for the choice of injectors’).
- Fix the warning label supplied with the appliance. This label states that the gas cooktop has been converted for use with LPG/Natural gas.
- Where the appliance data plate cannot be easily read with the appliance installed, a second conversion label should also be affixed to an adjacent surface along with the duplicate data plate.

Adjusting the minimum burner setting

- Follow the instructions under ‘Adjusting the minimum burner setting’ following.

Important!

- *If you are converting the cooktop from Natural gas to LPG, remove the gas pressure regulator before connecting the cooktop to the gas supply and replace with the test point adaptor supplied with the conversion kit.*
- *If you are converting the cooktop from LPG to Natural gas, remove the test point adaptor before connecting the cooktop to the gas supply and replace with the gas pressure regulator supplied with the conversion kit.*

Note:

- The burners are designed so that regulation of primary air is not required.

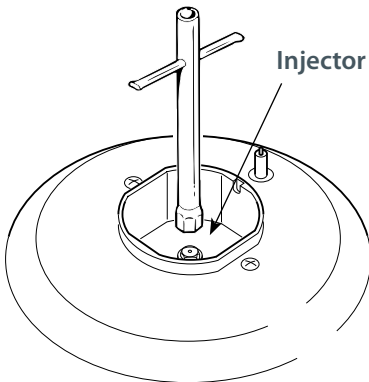

Fig. 7 Auxiliary, rapid and semi-rapid burners

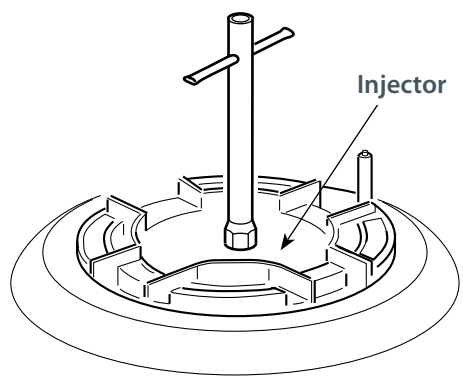

Fig. 8 Triple-ring wok burner

Adjusting the minimum burner setting

When changing from one type of gas to another, the minimum valve output must also be correct, considering that in this position the flame must be about 4 mm long and must remain lit even when the knob is turned quickly from the maximum to the minimum position.

The adjustment is performed with the burner lit, as follows:

- Turn the knob to the minimum position.
- Remove the knob.

On gas valves provided with adjustment screw in the centre of the shaft (Fig. 9)

- Using a screwdriver with max. diameter 3 mm, turn the screw inside the tap until the correct setting is obtained.

On gas valves provided with adjustment screw on the valve body (Fig. 10)

- Turn the screw "A" to the correct setting with a screwdriver.

For LPG, tighten the adjustment screw completely.

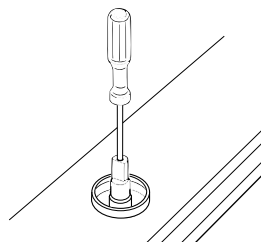

*Fig. 9 Minimum burner setting
- valves with adjustment screw
in the centre of the shaft.*

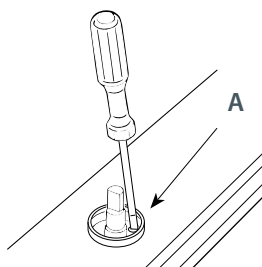

*Fig. 10 Minimum burner setting
- valves with adjustment screw
on the valve body.*

Important!

- *Installation must be carried out according to the manufacturer's instructions.*
- *Incorrect installation may cause harm and damage to people, animals or property, for which the manufacturer accepts no responsibility.*
- *If the installation requires alterations to the domestic electrical system, call a qualified electrician. The electrician should also check that the socket cable section is suitable for the power drawn by the appliance.*
- *Before carrying out any work on the electrical section of the appliance, it must be disconnected from the electricity supply.*
- *Connection to a good earth wiring system is absolutely essential and mandatory.*
- *The manufacturer accepts no responsibility for any inconvenience caused by failure to comply with this rule.*

Electrical requirements

- The appliance must be connected to the mains electricity supply checking that the voltage corresponds to the value given in the rating plate and that the electrical cable sections can withstand the load specified on the plate.
- The plug must be connected to an earthed socket in compliance with safety standards.
- If the appliance is supplied without plug, fit a standard plug which is suitable for the power consumed by the appliance.
- The wires in the power supply cable are coloured in accordance with the following code: Green/Yellow = Earth, Blue = Neutral, Brown = Active.
If the colours of the wires in the power cable to the appliance do not correspond with the coloured markings identifying the terminals in the junction terminal, proceed as follows:
 - 1 The wire which is coloured green and yellow must be connected to the terminal marked E (Earth) or coloured Green.
 - 2 The wire which is coloured blue must be connected to the terminal marked N (Neutral) or coloured Black.
 - 3 The wire which is coloured brown must be connected to the terminal marked L (Live) or A (Active) or coloured Red.
- A suitable disconnection switch must be incorporated in the permanent wiring, mounted and positioned to comply with the local wiring rules and regulations. The switch must be of an approved type installed in the fixed wiring and provide a 3 mm air gap contact separation in all poles in accordance with the local wiring rules.
In Australia and New Zealand, a switch of the approved type with a 3 mm air gap must be installed in the active (phase) conductor of the fixed wiring.
- The power supply cable must not touch the hot parts and must be positioned so that it does not exceed 50°C above ambient.
- Once the appliance has been installed, the switch or socket must always be accessible.
- If the power supply cable is damaged, it must be replaced by the manufacturer or its Service Agent or a similarly qualified person in order to avoid a hazard.

Wiring diagram

- PA Ignition switch
- A Ignition coil
- M Terminal block
- CA Spark electrode

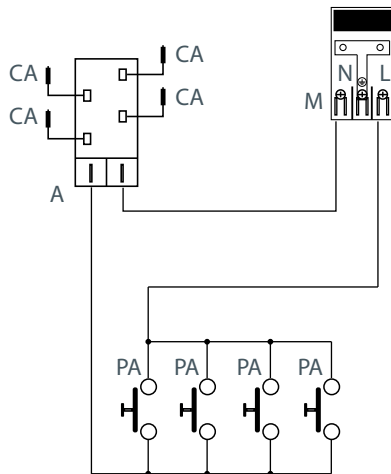

Fig. 11

About your new cooktop

Thank you for buying a Fisher & Paykel gas cooktop. Once it is installed and ready to use, you will want to know everything about it to make sure you get excellent results right from the start. This guide introduces you to all its special features. We recommend you read the whole guide before using your new cooktop, for both safety and cooking success.

Before using your new cooktop

Before using your new cooktop, please:

- Read this user guide, taking special note of the 'Safety and warnings' section.
- Plug the cooktop into the electricity supply and turn it on so the electronic ignition will work.

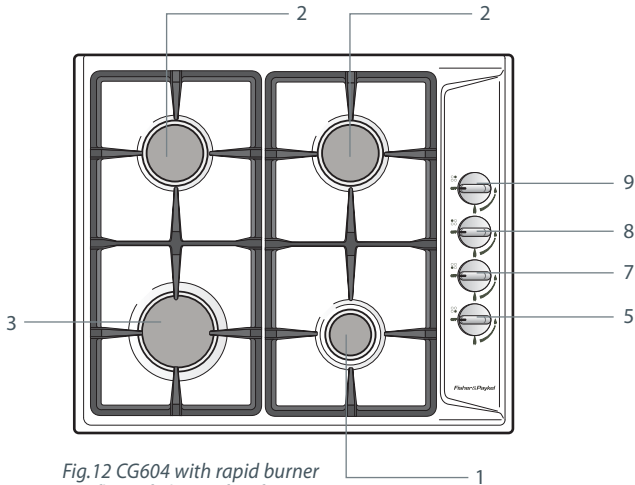

*Fig.12 CG604 with rapid burner
(no flame failure safety feature)
(not available in New Zealand)*

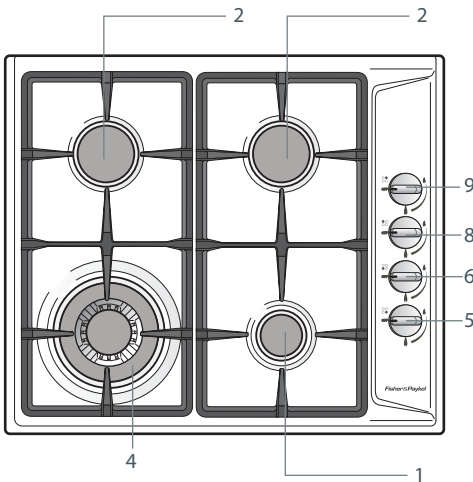

*Fig.13a CG604 with wok burner
(with flame failure safety feature)*

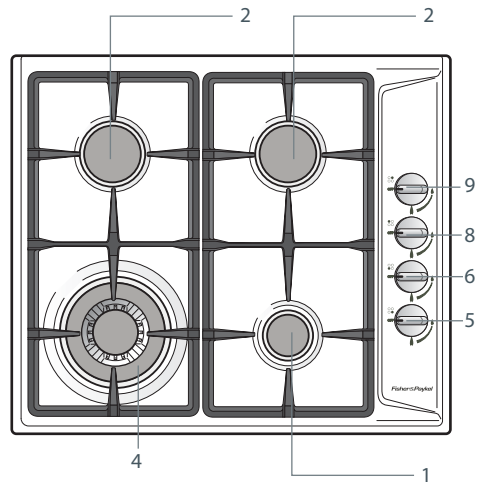

*Fig.13b CG604 with wok burner
(no flame failure safety feature)
(not available in New Zealand)*

- 1 Auxiliary burner
- 2 Semi-rapid burner
- 3 Rapid burner
- 4 Triple-ring wok burner
- 5 Auxiliary burner knob

- 6 Wok burner knob
- 7 Rapid burner knob
- 8 Left semi-rapid burner knob
- 9 Right semi-rapid burner knob

18 Using your cooktop

Gas burners

The knob (Fig. 14) controls the flow of gas through the safety valve.

- **OFF** = closed valve

-  = maximum flow

-  = minimum flow

You can choose to cook at any heat between  and , but never between  and OFF.

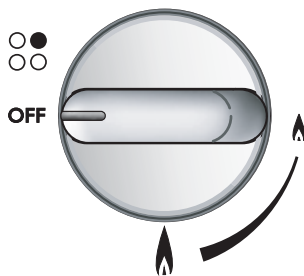

Fig. 14a Burner knob and symbols (models without flame failure safety feature)

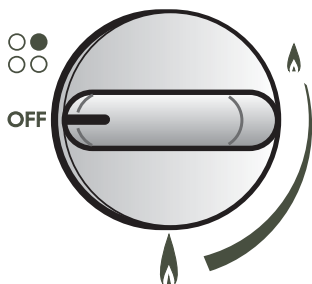





Fig. 14b Burner knob and symbols (models with flame failure safety feature)

Using the burners

- 1 Choose the control knob for the burner you want to use.
- 2 Press the knob down gently and turn it anticlockwise to the  position. The igniters on all the burners will spark.

Flame failure models only: Hold down the knob for approximately 10 seconds after the burner has lit. Releasing the knob too soon will extinguish the flame.

- 3 Adjust the flame anywhere between the  and  positions. Do not adjust the flame between  and OFF.
- Note: If the burner does not light within 15 seconds, turn the control knob off and wait at least one minute before trying again.
- 4 After use, always turn the knobs to the off position. For models without the flame failure safety feature, you should also close the cock valve on the gas bottle or the main gas supply line.

Flame failure safety feature (some models only)

Some cooktop models have a flame failure safety device. These models have a flame failure probe as well as the ignitor (see Fig 16).

The flame failure probe cuts off the gas supply to the burner if the flame is blown out.

When lighting the burner on flame failure models, hold down the knob for approximately 10 seconds after the burner has lit. Releasing the knob too soon will extinguish the flame.

If the flames are accidentally extinguished, turn off the burner and do not try to light it again for at least one minute (to allow the gas to disperse).

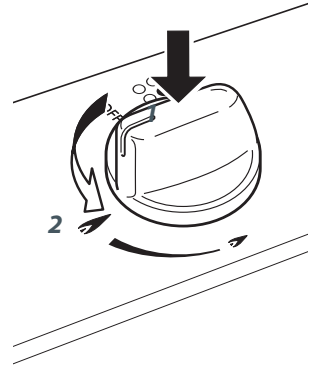

Fig. 15a Pushing then turning the control knob (models **without** flame failure safety feature)

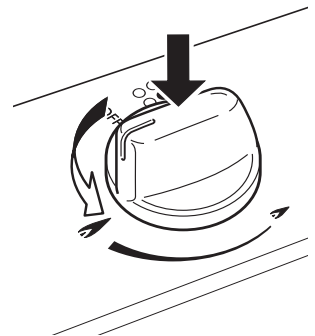

Fig. 15b Pushing then turning the control knob (models **with** flame failure safety feature)

If a burner does not light

Check that:

- The cooktop is plugged in and the electricity is switched on.
- The gas is turned on.
- The gas bottle is not empty (if you are using bottled gas).
- *Flame failure models only:*
You have held down the knob for at least 10 seconds.
- The ignitors are sparking. If the ignitors are not sparking, they may be dirty or wet. Clean them with a toothbrush and methylated spirits, as shown in Fig. 16.

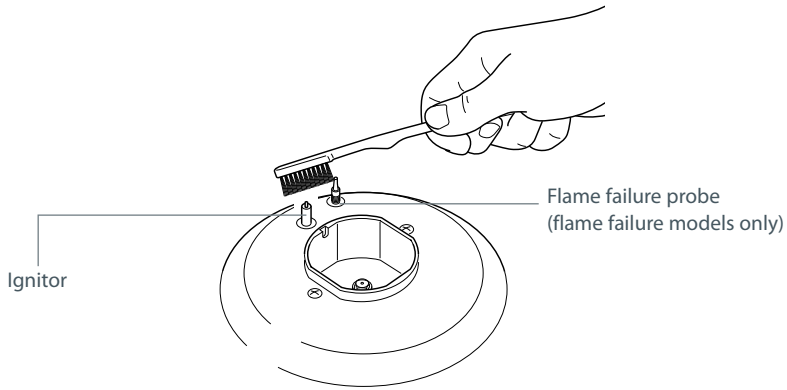

Fig.16 Cleaning the ignitor and probe

If the flame is irregular

If the flame is yellow or irregular, check that the burner parts, including the burner cap, are:

- Clean and dry.
- Positioned correctly as shown in Figs. 19 and 20.
- See also 'Troubleshooting'.

Matching cookware to burner

Use flat-bottomed pans, and make sure they match the size of the burner, as shown in the following table. A small pot on a large burner is not efficient.

Diameters of pans which may be used on the cooktop

Burners	Minimum	Maximum
Auxiliary	12 cm	14 cm
Semi-rapid	16 cm	24 cm
Rapid (some models only)	24 cm	26 cm
Triple-ring wok (some models only)	26 cm	28 cm
	Maximum diameter for woks: 36 cm	

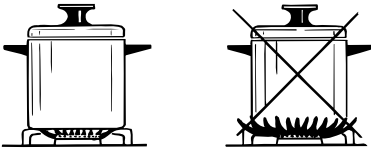

Fig. 17a Correct and incorrect matching



Fig. 17b Efficient and inefficient saucepan bottoms

Wok stand - models fitted with triple-ring wok burner only (Fig. 18b)

The wok stand fits over the triple-ring wok burner trivet.

Important!

- *Using a wok without the stand may cause the wok to tip or the wok burner to operate incorrectly.*
- *Do not use the stand for ordinary, flat-bottomed saucepans.*
- *The wok stand MUST BE PLACED ONLY over the triple-ring wok burner trivet.*

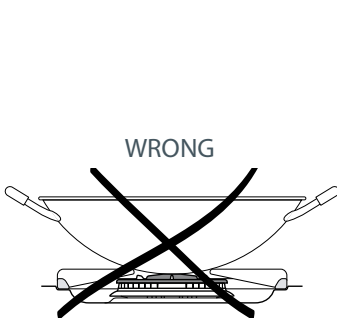

Fig. 18a Incorrect use of wok

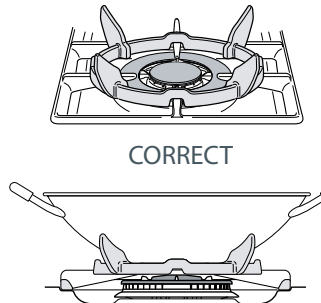

Fig. 18b Correct use of wok on triple-ring wok burner

General advice

Maintenance Period	Description
Daily	Clean gas cooktop as per following instructions.
Monthly	Remove all burner parts, and clean using a non-abrasive detergent. Rinse in cold water, dry thoroughly, and replace. Clean the ignitor carefully, using a toothbrush and methylated spirits.
Every 3-4 years	Contact your local authorised gas Service Agent to perform a thorough check on all gas components on the gas cooktop.

- Before cleaning, you must ensure that the cooktop is switched off.
- Clean the cooktop regularly – do not let stains become burnt on.
- Allow the appliance to cool down before cleaning.
- Avoid leaving acidic substances (lemon juice, vinegar etc.) on the surfaces.
- The control knobs may be removed for cleaning but care should be taken not to damage the seal.
- Do not clean cooktop parts in a self-cleaning oven.
- Do not use a steam cleaner to clean any part of your cooktop.
- For stubborn stains, see the 'Cleaning chart'.

Enamelled parts

- Clean the enamelled parts with a sponge and soapy water only or other non-abrasive products.
- Dry preferably with a microfibre or soft cloth.
- If acidic substances such as lemon juice, tomato sauce, vinegar etc. are left in contact with the enamel for a long time, they will damage the surface.

Stainless steel surfaces

- Stainless steel parts should be rinsed with water and dried with a microfibre or soft cloth.
- Dry thoroughly to avoid leaving water marks. For extra shine on stainless steel, use a stainless steel polish.
- Clean brushed stainless steel in the direction of the grain.
- For persistent dirt, use specific non-abrasive products available commercially or a little hot vinegar.
- Note: regular use could cause discolouring around the burners, because of the high flame temperature.

Burners and trivets

- You can remove and clean these parts with hot soapy water or other appropriate products - see 'Cleaning chart'.
- After cleaning, check that the burners and their flame spreaders are dry before replacing correctly.
- It is very important to check that the burner flame spreader and the cap have been correctly positioned. Failure to do so can cause serious problems.
- Note: to avoid damage to the electronic ignition, do not try to light a burner without all burner parts correctly in place.

Replacing the burners

- It is very important to check that the burner flame spreader and the cap have been correctly positioned (see Fig. 19). Failure to do so can cause serious problems.
- Check that the ignitor (Figs. 19 and 20) is always clean to ensure trouble-free sparking.
- In the models with the flame failure safety device, check that the probe (Figs. 19a and 20) next to each burner is always clean to ensure correct operation of the safety valves.
- Both the ignitor and probe must be very carefully cleaned using a toothbrush and methylated spirits (Fig.16).

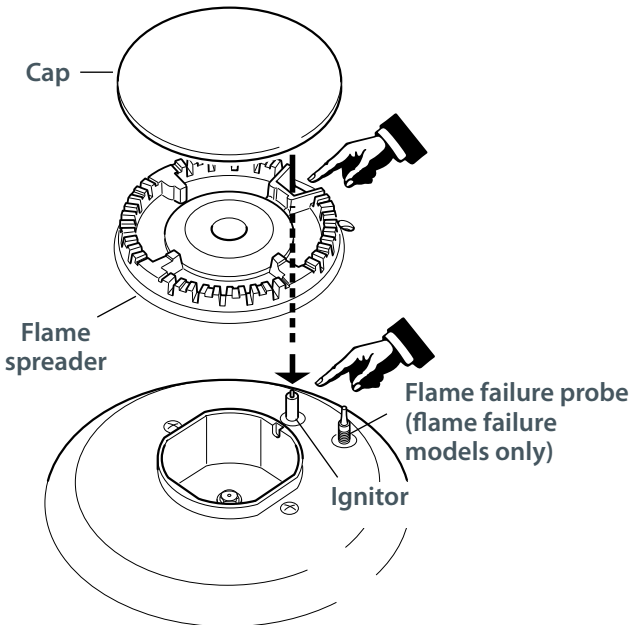

Fig. 19a Correct line-up of auxiliary, rapid and semi-rapid burner parts

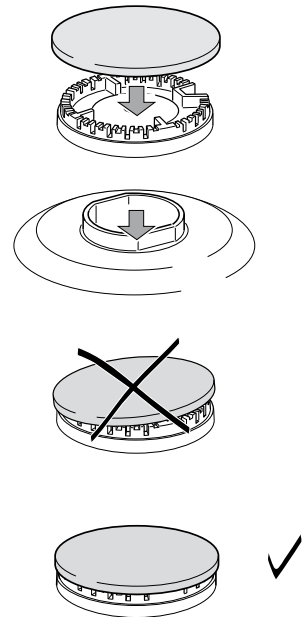

Fig. 19b Replacing the auxiliary, rapid and semi-rapid burner cap

Replacing the triple-ring wok burner

Fit the burner spreader to the housing as shown by the arrow in Fig. 20. Make sure the burner is not able to rotate (Fig. 21).

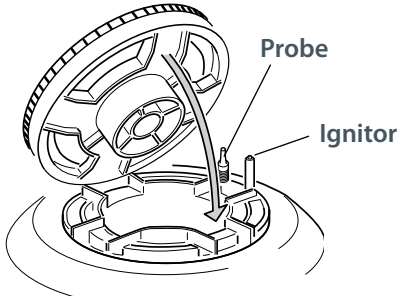

Fig. 20 Fitting the burner spreader to the housing.

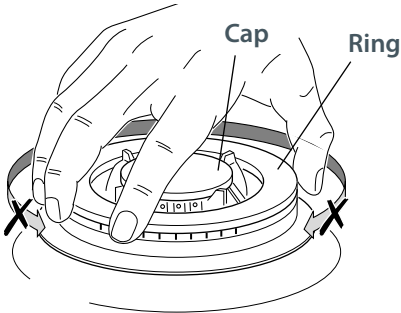

Fig. 21 Correct positioning of cap and ring - triple-ring wok burner

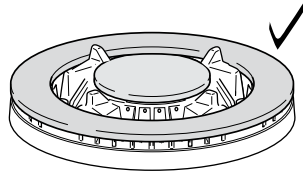
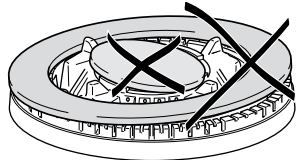
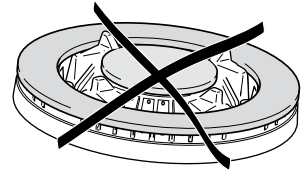

Fig. 22 Incorrect and correct positioning of cap and ring - triple-ring wok burner

Cleaning chart

Cooktop part	Cleaning	Important
Trivets, burner caps	<ul style="list-style-type: none"> ▪ Hot soapy water and nylon scourer. ▪ Soak removeable parts in a solution of biological clothes-washing detergent. ▪ Mild abrasive cream cleaners. ▪ Fume-free or heavy-duty oven cleaners (follow manufacturer's instructions). 	<p>Always allow cooktop parts to cool completely before cleaning them.</p> <p>Always apply minimal pressure with abrasive cleaners.</p> <p>Clean spills regularly before they become burnt on.</p>
Burner parts	<ul style="list-style-type: none"> ▪ Hot soapy water. ▪ To clear the holes use a stiff nylon brush or wire eg straight-ended paper clip. ▪ Mild abrasive cream cleaners. 	<p>Reassemble the burner parts correctly.</p>
Control knobs	<ul style="list-style-type: none"> ▪ Hot soapy water and a soft cloth. 	
Stainless steel base	<ul style="list-style-type: none"> ▪ Soak stains under a hot soapy cloth, rinse and dry thoroughly. ▪ Hard water spots can be removed with household white vinegar. ▪ Non-abrasive stainless steel cleaners. Regular use of a stainless steel polish will reduce fingerprints and other marks. ▪ Heavy soiling can be removed with fume-free or heavy-duty oven cleaner (follow manufacturer's instructions). 	<p>Never use harsh/abrasive cleaning agents as they will damage the stainless steel finish.</p> <p>Chlorine or chlorine compounds in some cleaners are corrosive to stainless steel and may damage the appearance of your cooktop. Check the label on the cleaner before using.</p> <p>The graphics are etched onto the steel and will not rub off.</p>
Enamel base	<ul style="list-style-type: none"> ▪ Use soft cloth or non-abrasive sponge and soapy water. Do not use abrasive products. 	<p>Clean spills regularly before they become burnt on.</p>
Ignitors	<ul style="list-style-type: none"> ▪ Toothbrush and methylated spirits. 	<p>A dirty or wet ignitor will prevent the burner lighting efficiently.</p>
Probe (in models with flame failure safety valves)	<ul style="list-style-type: none"> ▪ Toothbrush and methylated spirits. 	<p>A dirty probe may prevent the safety valve from working effectively.</p>

Troubleshooting chart

Problem	Possible solutions
A burner does not light	<p>Check the cooktop is plugged in and the electricity is switched on. Check the gas supply valve is turned on and the supply to the house is working. You should hear the gas when you turn a burner on.</p> <p>Check the gas bottle is not empty.</p> <p>The ignitors may be dirty. Clean them with a toothbrush and methylated spirits.</p> <p>The burner parts may not be located properly. Check the assembly and make sure the burner cap is sitting flat.</p>
My burner flames are yellow or hard to start	<p>The burner parts may not be located properly. Check the assembly and make sure the burner cap is sitting flat.</p> <p>If you use bottled gas, this may indicate you are getting near the end of the bottle.</p> <p>Check the burner parts are clean and dry.</p> <p>The gas pressure may not be at the correct level. Check with your service person or installer.</p> <p>Your cooktop may not be set up for the gas you are using. Check this with your service person or installer.</p>
One of my burners has an uneven flame	<p>Check the burner parts are clean and dry. Check the assembly and make sure the burner cap is sitting flat.</p>
The flame goes out at low settings	<p>The gas supply pressure may be low. Check this with your service person or installer.</p> <p>The low setting may have been adjusted incorrectly. Check this with your service person or installer.</p> <p>If you use bottled gas, this may indicate you are getting near the end of the bottle.</p>
My burners do not turn down much (when running on bottled gas or LPG)	<p>Your cooktop may not have been adjusted correctly. Check this with your service person or installer.</p>
The flame tips are very yellow	<p>Call your service person to service the cooktop.</p>
There are objectionable odours	<p>Call your service person to service the cooktop.</p>
The flame appears to lift off the burner	<p>Call your service person to service the cooktop.</p>
There is an electricity failure	<p>If there is an electricity failure, you can still use your cooktop. Light the burners by holding a match close to the side of the burner and turning the control knob to the High position. Wait until the flame is burning evenly before adjusting.</p>

Before you call for service or assistance ...

Check the things you can do yourself. Refer to the installation instructions and your user guide and check that:

- 1 your product is correctly installed.
- 2 you are familiar with its normal operation.

If after checking these points you still need assistance or replacement parts, please refer to the Service & Warranty book for warranty and after-sales service details or contact us through our local website listed on the back cover.

Product details

Fisher & Paykel Ltd

Model _____ Serial no. _____

Date of purchase _____ Purchaser _____

Dealer _____ Suburb _____

Town _____ Country _____

Copyright © Fisher & Paykel 2009. All rights reserved.

The product specifications in this booklet apply to the specific products and models described at the date of issue. Under our policy of continuous product improvement, these specifications may change at any time. You should therefore check with your Dealer to ensure this booklet correctly describes the product currently available.

www.fisherpaykel.co.nz
www.fisherpaykel.com.au

NZ AU

Gas cooktop user guide

Published: 04/2009

Part No. 599371 D

F&P Italy Part No. 1103290-β1