

Installation instructions and User guide

Gas cooktops

CG705 models

GB IE

Safety and warnings	2
Installation instructions	6
Introduction	22
Using your cooktop	23
Care and cleaning	26
Troubleshooting	30
Warranty and service	31

Important!

SAVE THESE INSTRUCTIONS

The models shown in this manual may not be available in all markets and are subject to change at any time. For current details about model and specification availability in your country, please visit our local website listed on the back cover or contact your local Fisher & Paykel dealer.

2 Safety and warnings

⚠ WARNING!



Cut Hazard

Beware of sharp edges when handling stainless steel appliances.
Failure to use caution could result in injury or cuts.

⚠ WARNING!



Electrical Shock Hazard

Before carrying out any work on the electrical section of the appliance, it must be disconnected from the mains power supply.
Connection to a good earth wiring system is essential and mandatory.
Failure to follow this advice may result in death or electrical shock.

Important safety precautions

Installation

- *Read these instructions carefully before installing or using this product.*
- *Please make this information available to the person responsible for installing the product as it could reduce your installation costs.*
- *This appliance must be installed in accordance with these installation instructions, local gas fitting regulations, municipal building codes, electrical wiring regulations, and any other relevant statutory regulations.*
- *This appliance shall only be serviced by authorised personnel.*
- *Always disconnect the cooktop from mains power supply before carrying out any maintenance operations or repairs.*
- *In the room where the cooktop is installed, there must be enough air to allow the gas to burn correctly, according to the current local regulations.*

- *Particular attention shall be given to the relevant requirements regarding ventilation.*
- *This product should not be sealed into the bench with silicone or glue. Doing so will make future servicing difficult. Fisher & Paykel will not be liable for costs associated with releasing such a product, nor for repairing damage that may be incurred in doing this.*
- *No combustible material or products should be placed on this product at any time.*
- *Do not spray aerosols in the vicinity of this product while it is in operation.*

! WARNING!**Hot Surface Hazard**

This appliance becomes hot during use.

Do not touch the cooktop components, burners, trivets/pan supports or the base when hot.

Before cleaning, turn the burners off and make sure the whole cooktop is cool.

Failure to follow this advice may result in serious injury.

! WARNING!**Explosion Hazard**

Do not store flammable materials such as gasoline near the cooktop. Do not spray aerosols near the cooktop during use.

Failure to follow this advice may result in death or serious injury.

! WARNING!**Electrical Shock Hazard**

Switch off the cooktop at the wall before carrying out cleaning or maintenance.

Failure to follow this advice may result in death or electrical shock

Important safety precautions

Operation

- *Children, or persons with a disability which limits their ability to use the appliance, should have a responsible person to instruct them in its use. The instructor should be satisfied that they can use the appliance without danger to themselves or their surroundings.*
- *If the power supply cable is damaged, it must only be replaced by an authorised person. Ensure that the electrical connection plug is accessible after installation.*
- *This appliance should be connected to a circuit that incorporates an isolating switch providing full disconnection from the power supply.*
- *Do not use an asbestos mat or decorative covers between the flame and the saucepan as this may cause serious damage to your cooktop.*
- *Do not place aluminium foil or plastic dishes on the cooktop burners.*
- *Do not let large saucepans or frying pans overlap the bench as this can deflect heat onto your benchtop and damage the surface.*
- *Do not let large saucepans, frying pans or woks push any other pans aside. This could make them unstable or deflect heat onto your benchtop and damage the surface.*
- *Do not use a steam cleaner for cleaning this cooktop.*
- *Saucepan handles may be hot to touch. Ensure saucepan handles do not overhang other gas burners that are on. Keep handles out of reach of children.*
- *Keep children away from the cooktop when it is in use.*
- *Household appliances are not intended to be played with by children*
- *Do not stand on this appliance.*
- *Do not place or drop heavy objects on this appliance.*
- *After use, ensure that the knobs are in the off position.*
- *This appliance shall not be used as a space heater.*
- *The use of a gas cooking appliance results in the production of heat and moisture in the room in which it is installed. Ensure the kitchen is well ventilated. Keep natural ventilation holes open or install a mechanical ventilation device (mechanical extractor hood). Prolonged intensive use of the appliance may call for additional ventilation, for example opening of a window, or more effective ventilation, for example increasing the level of mechanical ventilation where present.*
- *After having unpacked the appliance, check to ensure that it is not damaged. In case of doubt, do not use it and consult your supplier or a professionally qualified technician. Packing elements (i.e. plastic bags, polystyrene foam, nails, packing straps, etc.) should not be left around within easy reach of children, as these may cause serious injuries.*

6 Installation instructions

Cooktop and cutout dimensions

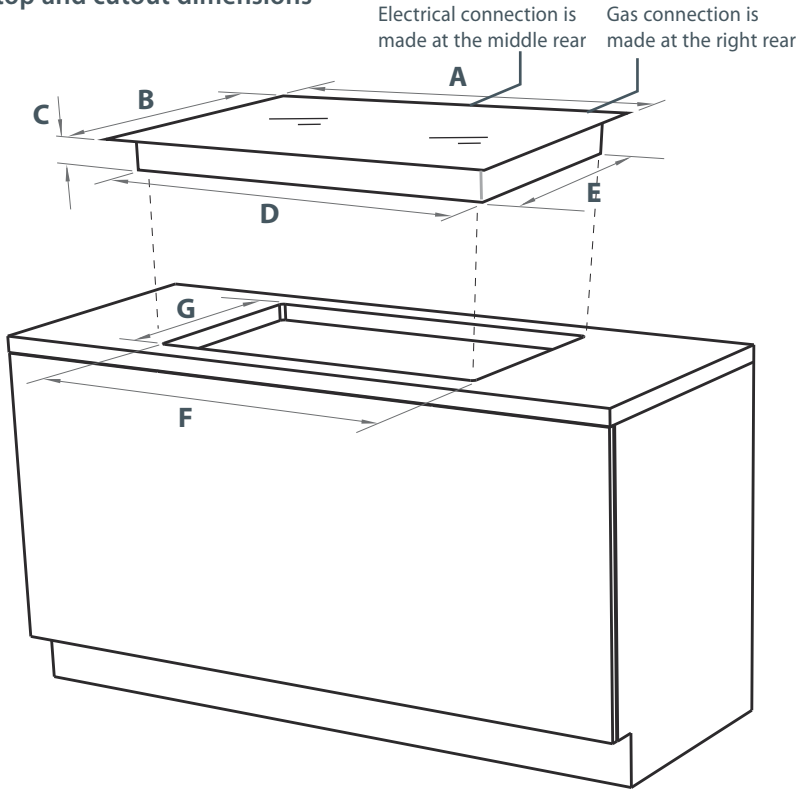

Cooktop and cutout dimensions (mm)

A	overall width of cooktop	680
B	overall depth of cooktop	500
C	height of chassis (below top of bench)	35
D	width of chassis	550
E	depth of chassis	440
F	overall width of cutout	560
G	overall depth of cutout	480

CG705

Clearances

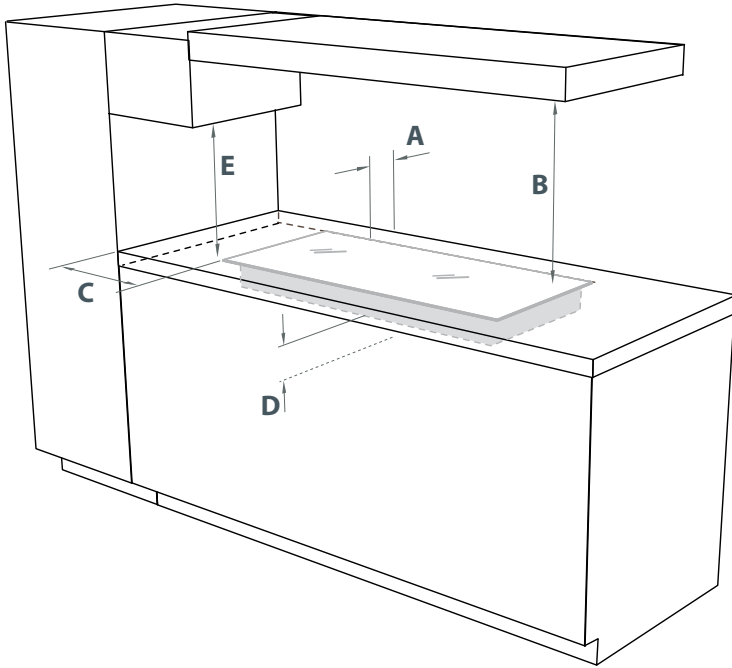

Clearances (mm)

CG705

A	minimum clearance from rear edge of cutout to: nearest combustibles surface	60
B	minimum clearance from cooktop to: rangehood	650
C	minimum clearance from side edges of cutout to: nearest combustibles surface	200
D	minimum clearance below top of benchtop to: combustibles surface nearest non-combustibles surface (eg thermal protection barrier)	65 65
E	minimum clearance from benchtop to: overhead cabinet not directly above the cooktop	450

Installation instructions

- The appliance may be installed in a suitable room in accordance with the current laws in force.
- The appliance is designed and approved for domestic use only and should not be installed in a commercial, semi-commercial or communal environment.
- Installing the appliance in any of the above environments will void the warranty and could affect any third-party or public liability insurances you may have.
- The appliance must be installed in compliance with regulations in force.
- Installation technicians must comply with current laws in force concerning ventilation and the evacuation of exhaust gases.
- Always unplug the appliance before carrying out any maintenance operations or repairs.
- The walls of the units around the appliance must not be higher than the benchtop and must be capable of resisting temperatures of 105°C above room temperature.
- Do not install the appliance near flammable materials (eg curtains).
- You must install a thermal protection barrier between the base of the appliance and the built-in unit or an oven. See Fig. 1 below.
- If the appliance is installed over a built-in oven, the oven should be fitted with a cooling fan and the two appliances should be connected to the gas and electricity supply with independent connections.

The thermal protection barrier must be:

- removable
- heat-resistant
- made from low thermal conductivity material
- at least 30 mm below the base of the cooktop

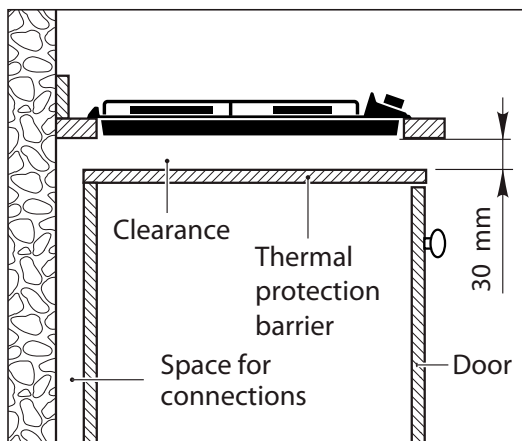
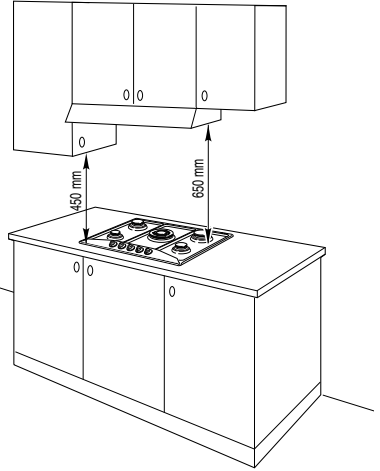

Fig. 1 Location of thermal protection barrier

Ventilation requirements (all countries except UK)

Providing adequate ventilation

- The installer must refer to the current local regulations.
- The room accommodating the gas cooktop must have adequate natural draught to allow combustion of the gas.
- The flow of air must come directly from one or more air vents made in the outside walls with a free area of at least 100 cm².
- The vents must be positioned close to the floor, preferably on the opposite side to the gas burners of your cooker (as shown in Figs. 1a and 1b). The vents must be designed in such a way that they cannot be obstructed either from the inside or the outside.
- When it is not possible to provide the necessary vents, the draught may be supplied from an adjacent room, ventilated in the required manner, provided it is not a bedroom or an area at risk. In this event, the kitchen door must be opened to allow the draught to enter the room.



Extracting cooking and gas fumes

Important!

This appliance is not connected to a device extracting the products of gas combustion. Such a device must be installed and connected in accordance with the installation rules in force. Take special care to provide adequate room ventilation as well.

- To eliminate cooking and gas fumes, extractor hoods ducted directly to the outside must be installed. (Fig. 1a).
- If this is not possible, an electric fan installed in an external wall or window may be used; the fan should have a capacity to circulate air at an hourly rate of 3 to 5 times the total volume of the kitchen (Fig. 1b). The fan can only be installed if the kitchen has suitable vents to allow air to enter, as described under 'Providing adequate ventilation' above.

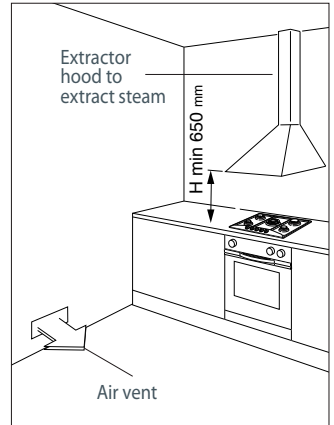

Fig. 2a Ventilation with an extractor hood

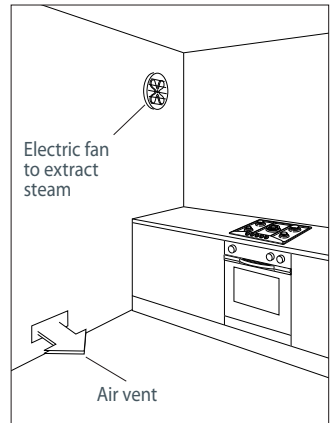

Fig. 2b Ventilation with an electric fan

Ventilation requirements (United Kingdom only)

- The appliance should be installed in a room or space with an air supply in accordance with BS 5440:2 2000.
- For rooms with a volume of less than 5 m³, permanent ventilation through a free area of at least 100 cm² will be required.
- For rooms with a volume between 5 m³ and 10 m³, permanent ventilation through a free area of at least 50 cm² will be required, unless the room has a door which opens directly to the outside air, in which case no permanent ventilation is required.
- For rooms with a volume greater than 10 m³, no permanent ventilation is required.

Important!

Regardless of room size, all rooms containing the appliance must have direct access to the outside air via an openable window or equivalent.

- Where there are other fuel-burning appliances in the same room, BS 5440-2: 2000 should be consulted to determine the correct amount of free area ventilation requirements.
- The above requirements also allow for use of a gas oven and grill, but you need to consult a qualified engineer if there are other gas-burning appliances in the same room.

Applying the seals

- 1 Turn the cooktop upside down and place it on a soft surface.
- 2 Spread the longer seal "A" around the left, rear and right sides (Fig. 3a).
- 3 Using a sharp cutter or a pair of scissors, cut the excess seal "C" and put aside (Fig. 3b).
- 4 Spread the seal "B" around the left, front and right edges of the cooktop (Fig. 3c).
- 5 Spread the seal "C" along the rear edge of the cooktop (Fig. 3d), making sure that the beginning and the end overlap at the junctions with seal "B" (Fig. 3e).

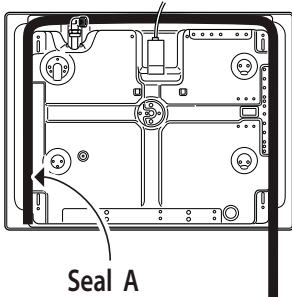

Fig. 3a

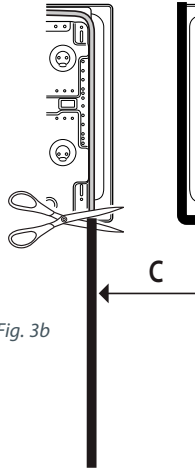

Fig. 3b

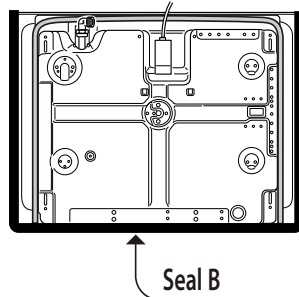

Fig. 3c

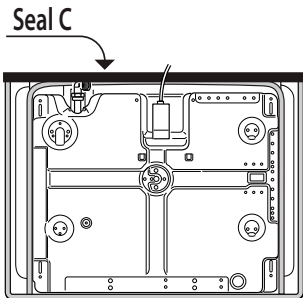

Fig. 3d

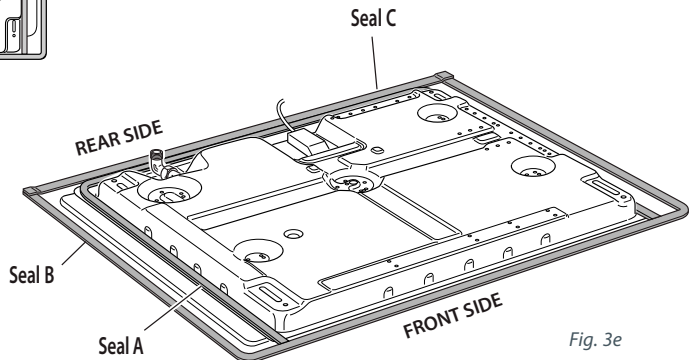

Fig. 3e

12 Installation instructions

Fastening the cooktop to the bench

- 1 With the cooktop turned upside down, mount the supplied front and rear clamps (F and R) and screws (S) onto the cooktop, as shown (without tightening the screws).
- 2 Place the cooktop into the cutout, then tighten the screws to clamp the cooktop securely to the bench.
- 3 Using a sharp cutter or trimmer knife, trim the excess sealing material around the edge of the cooktop. Take care not to damage the benchtop.

Note: if your bench is thicker than 40 mm, recess the underside to between 20 and 40 mm.

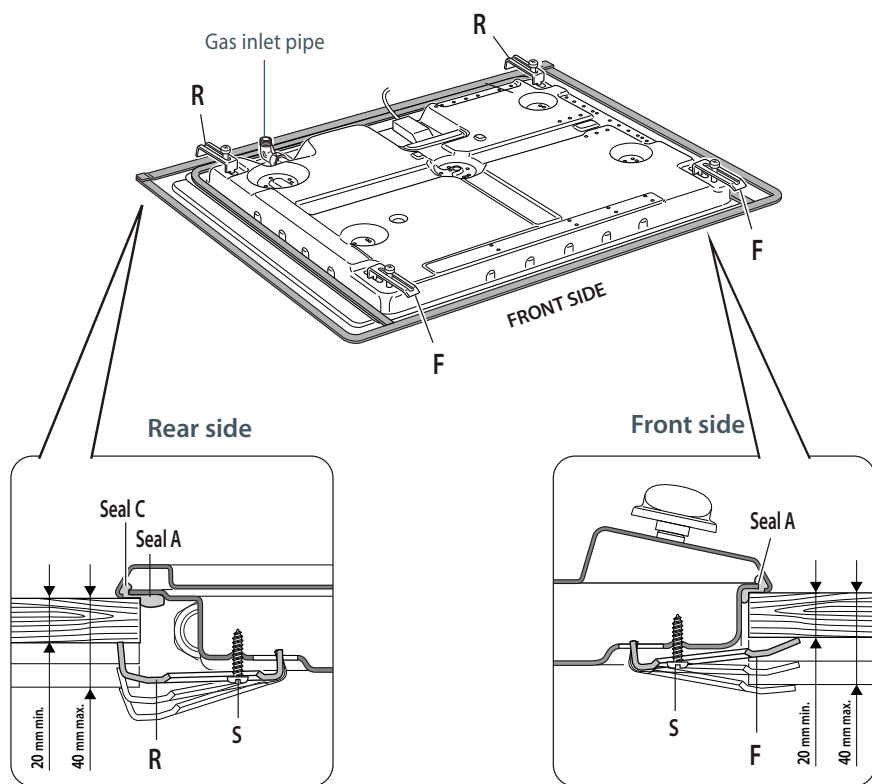

Fig. 4 Fastening the cooktop to the bench

Gas installation requirements

- This appliance is adjusted at the factory for use on Natural gas.
- To use it on LPG, it will first have to be converted. If the LPG conversion kit is not supplied with the appliance, contact your nearest Authorised Service Centre.

Installation and service regulations (United Kingdom only)

Important!

This appliance must be installed and serviced only by a suitably qualified and registered person, and in accordance with the current editions of the following standards and regulations or other locally applicable regulations:

- *Gas Safety (Installation and Use) Regulations*
- *Building Regulations*
- *British Standards*
- *Regulations for Electrical Installation*

Failure to install the appliance correctly could invalidate any manufacturer's warranty and lead to prosecution under the above-quoted regulation.

Additional gas connection requirements (United Kingdom only)

- We recommend connecting the appliance to the gas with a flexible hose made to BS5386.
- Flexible hoses can be used where the sited ambient temperature of the hose will not exceed 70°C. Any hose used must comply with BS 669, Part 1 and be of the correct construction for the type of gas being used.
- Flexible hoses designed for Natural gas MUST NOT be used for supplying LPG (LPG flexible hoses can be identified by either a red band or strip on their outer coating).

Installation and service regulations (all countries)

Important!

- *This appliance must be installed and serviced only by a suitably qualified, registered installer with technical knowledge of both gas installation and electricity. The installation or service must comply with the current editions of the applicable standards, regulations and codes of practice governing gas and electrical installations.*
- *Failure to install the appliance correctly could invalidate any manufacturer's warranty.*

Connecting the cooktop to the gas supply

The gas connection fitting (Fig. 5) is made up of:

- the floating nut
 - the elbow
 - the washer.
- If using a flexible hose, make sure it does not come into contact with moving parts.
 - To maintain the minimum 30 mm clearance requirement below the base of the cooktop, the rear of the chassis is recessed to provide a channel for the appliance inlet pipe.
 - The gas connection fitting can be turned in the direction required (but never in a vertical or horizontal position) after loosening the elbow and floating nut connection.
 - Never attempt to turn the elbow without having first loosened the floating nut.
 - The supplied washer guarantees a good seal for the gas connection. We recommend that you replace it on the slightest sign of wear, deformation or imperfection.
 - After connecting the gas supply, check the piping and connections for leaks as required by local regulations. The presence of bubbles indicates a leak. Tighten or replace connections as appropriate, then re-check for leaks.

Important!

Do not use any naked flame to check for leaks.

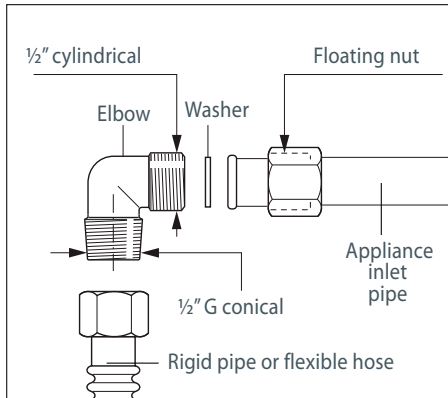

Fig. 5 Gas connection fitting

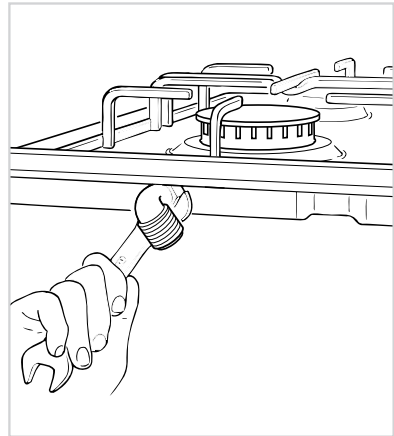

Fig. 6 Turning the gas connection fitting

When connecting the cooktop to the gas supply with rigid pipes or a flexible hose (which must comply with BS 669 in the UK), make sure that:

- you use rigid pipes or a flexible hose compliant with applicable local regulations. The flexible hose shall be of the correct construction for the type of gas being used and of the correct size to maintain the heat output of the appliance
- the connection with rigid metal pipes does not cause stress or pressure to the gas piping.
- the flexible hose is not under tension, twisted, kinked, or too tightly bent, neither while the cooktop is in use nor while it is being connected or disconnected
- the flexible hose is not longer than 2000 mm (or refer to applicable local regulations) and does not come into contact with sharp edges, corners, or moving parts, as these may cause abrasion. Use a single flexible hose only; never connect the cooktop with the more than one flexible hose.
- the flexible hose can easily be inspected along its entire length to check its condition; if it has an expiry date, it should be replaced before that date
- if using a flexible hose which is not entirely made of metal, make sure that it does not come into contact with any part of the cooktop with a surface temperature of 70°C or above.
- the rigid pipe or flexible hose is replaced if it shows signs of damage
- the flexible hose is not subject to excessive heat by direct exposure to flue products or by contact with hot surfaces
- the socket into which the plug of the flexible hose fit is permanently attached to a firmly fixed gas installation pipe and is positioned so that the hose hangs freely downwards.
- the plug of the flexible hose is accessible after installation, so that it can be disconnected for service or removal
- you inform the customer that the rigid pipe or flexible hose should not be subjected to corrosion by cleaning agents.

Leak-testing and flame-testing the cooktop

- 1 After connecting the gas supply, check the piping and connections for leaks as required by local regulations. The presence of bubbles indicates a leak, tighten or replace connections as appropriate, then re-check for leaks.

Important!

Do not use any naked flame to check for leaks.

- 2 The operation of the appliance MUST be tested before leaving.
- 3 Turn on the gas controls and light each burner. Check for a well-defined blue flame without any yellow tipping. If any abnormality is evident, check that the burner cap is located properly and the injector nipple is aligned correctly.
- 4 Check the minimum burner setting by quickly rotating the burner knobs from the maximum to the minimum position: the flame must not go out. If adjustment is required, see section 'Adjusting a burner's minimum gas rate setting' following.
- 5 If satisfactory performance cannot be obtained, check the installation and notify the local gas supply authority of a gas supply problem, or if it is an appliance problem, our Customer Service Centre should be called to obtain the nearest authorised Service Agent.

Table for the choice of injectors



Cat: II 2H3+

Gas type: G20	BURNERS	NOMINAL POWER (H ₅ - kW)	REDUCED POWER (H ₅ - kW)	Ø INJECTOR (1/100 mm)	GAS PRESSURE (mbar)
	Auxiliary (A)	1,00	0,30	72 (X)	20
	Semi-rapid (SR)	1,75	0,45	97 (Z)	
	Rapid (R)	3,00	0,75	115 (Y)	
	Triple ring (TR)	3,50	1,50	135 (T)	

Gas type: G30/G31	BURNERS	NOMINAL POWER (H ₅ - kW)	REDUCED POWER (H ₅ - kW)	Ø INJECTOR (1/100 mm)	GAS PRESSURE (mbar)
	Auxiliary (A)	1,00	0,30	50	28-30/37
	Semi-rapid (SR)	1,75	0,45	65	
	Rapid (R)	3,00	0,75	85	
	Triple ring (TR)	3,50	1,50	95	

Converting the cooktop to a different gas type

Important!

Only a suitably qualified and registered person may convert the cooktop to a different gas type.

To convert from one gas type to another, you need to replace the injectors, and then adjust the minimum gas rate setting.

Replacing the injectors

- 1 Remove the pan supports and burners from the cooktop.
- 2 Using a spanner, remove the injectors and replace them with ones suitable for the type of gas you are converting the cooktop to. See the 'Table for the choice of injectors'.
 - The burners are designed so that regulation of primary air is not required.

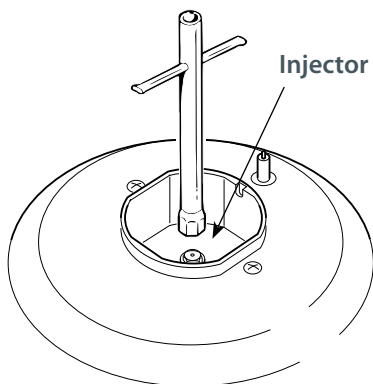

Fig. 7 Auxiliary, rapid and semi-rapid burners

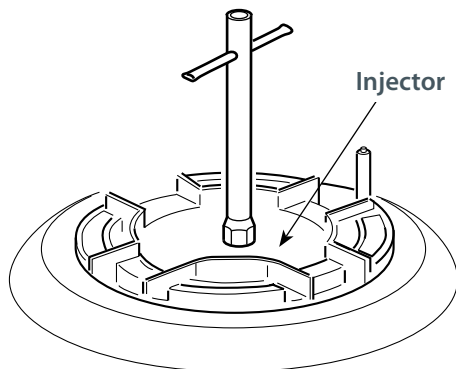

Fig. 8 Triple-ring wok burner

Adjusting a burner's minimum gas rate setting

- Check whether the flame spreads to all burner ports when the burner is lit with the gas valve set to the minimum position. If some ports do not light, increase the minimum gas rate setting.
- Check whether the burner remains lit even when the gas valve is turned quickly from the maximum to the minimum position. If the burner does not remain lit, increase the minimum gas rate setting.

To adjust the minimum gas rate setting

- 1 Make sure the burner is lit.
- 2 Turn the knob to the minimum position.
- 3 Remove the knob.
- 4 Using a screwdriver, turn the adjustment screw until the flame setting is correct.

For LPG, tighten the adjustment screw completely.

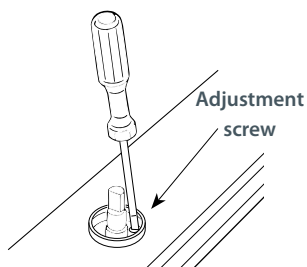

Fig. 9 Adjusting a burner's minimum gas rate setting

Electrical connection

Important!

- *This appliance must be earthed.*
- *Installation must be carried out according to the manufacturer's instructions.*
- *Incorrect installation may cause harm and damage to people, animals or property, for which the manufacturer accepts no responsibility.*
- *If the installation requires alterations to the domestic wiring system, call a qualified electrician. The electrician should also check that the socket cable section is suitable for the power drawn by the appliance. Before carrying out any work on the power section of the appliance, it must be disconnected from the electricity supply.*
- *The plug must be connected to an earthed socket in compliance with safety standards.*
- *Do not use adapters, reducers, a multi-outlet power board or branching devices when connecting this appliance to the mains power supply, as doing so can cause overheating and burning.*
- *The appliance must be connected to the mains power supply checking that the voltage corresponds to the value given in the rating plate and that the electrical cable sections can withstand the load specified on the plate.*
- *If the appliance is supplied without a plug, fit a standard plug which is suitable for the power consumed by the appliance.*
- *A suitable isolating switch providing full disconnection from the mains power supply must be incorporated in the permanent wiring, mounted and positioned to comply with the local wiring rules and regulations. The switch must be of an approved type and provide a 3 mm air gap contact separation in all poles in accordance with the local wiring rules. The switch or socket must be accessible with the appliance installed.*
- *The power supply cable must not touch any hot parts and must be positioned so that it does not exceed 75°C at any point along its length.*
- *If the power supply cable is damaged, it must be replaced by a cable of the same type. It can only be replaced by the manufacturer, its Service Agent or a similarly qualified person by a in order to avoid a hazard.*
- *As the colours of the wires in the power supply cable of this appliance may not correspond with the coloured markings identifying the terminals in your plug, proceed as follows:*

Colour of power supply cable wire

Green & Yellow

Blue

Brown

Colour or mark of plug terminal

"E" (Earth) or green or

"N" (Neutral) or black

"L" (Live) or red

Power supply cable section

Type H05V2V2-F, resistant to temperature of up to 90°C

Power supply

230 V~ 50/60 Hz 3 x 0.75 mm²

230 V

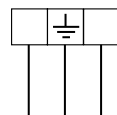

L1 PE N(L2)

Fig. 10 Connection diagram

For the United Kingdom and the Republic of Ireland only:

- The appliance must be connected to a 220-240V~50 Hz supply by means of a suitably earthed three-pin socket and should be protected by a 3A fuse in the plug.
- If the appliance is supplied without a plug, fit a rewirable 13A three-pin plug fitted with a 3A fuse. Should the fuse require replacement, it must be replaced with a fuse rated at 3A and complying with BS1362.
- If the mains plug is unsuitable for the socket at the place of installation or it has to be cut off for any other reason, make sure you dispose of the removed plug safely to prevent the hazard of electrical shock.
- There is a danger of electrical shock if the removed plug is inserted into any 13A socket outlet.
- If the appliance is connected directly to the fixed wiring, a double-pole switch of the electrical supply must be provided no further than 2 metres from the appliance.

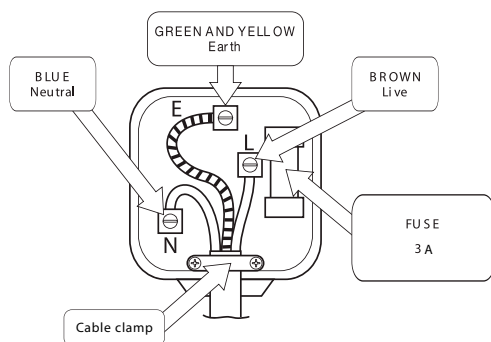

Fig. 11 Connection by a three-pin socket

Final checklist

TO BE COMPLETED BY THE INSTALLER



- Have you installed the clamps?
- Have you clamped the cooktop to the bench securely?
- Have you used the supplied washers?
- Have you leak-tested all connections?
- Is the cooktop set for the correct gas type and pressure?
- Are the injector sizes correct for the gas type?
- Is the cooktop earthed?
- Check that the power supply cable is NOT touching the cooktop.

OPERATION:

- Do all burners ignite individually and in combination?
- Do the burners remain lit when turned down?
- Are the flames consistent and appropriately sized?
- Have you demonstrated the basic operation to the customer?

Installer's name: _____

Installer's signature: _____

Installation company: _____

Date of installation: _____

LEAVE THESE INSTRUCTIONS WITH THE CUSTOMER

About your new cooktop

Thank you for buying a Fisher & Paykel gas cooktop. Once it is installed and ready to use, you will want to know everything about it to make sure you get excellent results right from the start. This guide introduces you to all its special features. We recommend you read the whole guide before using your new cooktop, for both safety and cooking success.

For more information, visit our local website listed on the back cover.

Before using your new cooktop

Before using your new cooktop, please:

- read this user guide, taking special note of the 'Safety and warnings' section
- ensure the power supply to the cooktop is turned on.

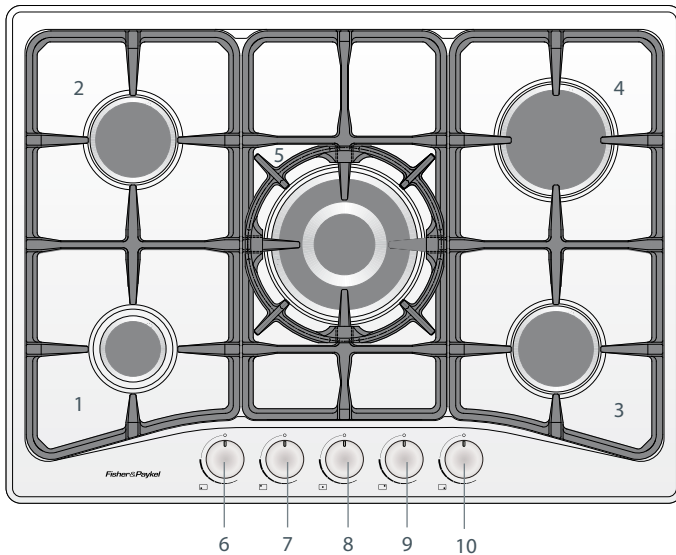

Fig.12 Cooktop layout

- | | |
|---------------------------|---------------------------------|
| 1 Auxiliary burner | 6 Auxiliary burner knob |
| 2 Left semi-rapid burner | 7 Left semi-rapid burner knob |
| 3 Right semi-rapid burner | 8 Triple-ring wok burner knob |
| 4 Rapid burner | 9 Rapid burner knob |
| 5 Triple-ring wok burner | 10 Right semi-rapid burner knob |

Gas burners

The knob (Fig. 13) controls the flow of gas through the safety valve.

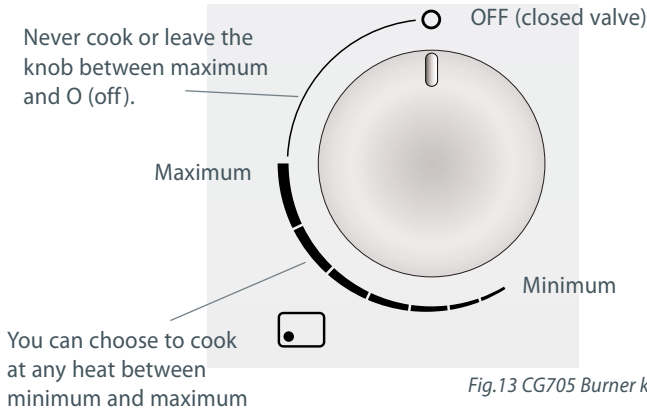

Fig.13 CG705 Burner knob

Using the burners

- 1 Choose the control knob for the burner you want to use.
 - 2 Press the knob down gently and turn it anticlockwise to the maximum position. The ignitors on all the burners will spark.
 - 3 Hold down the knob for approximately 10 seconds after the burner has lit.
Releasing the knob too soon will extinguish the flame.
 - 4 Adjust the flame anywhere between the maximum and minimum positions. Do not adjust the flame between maximum and O (OFF).
- Note: If the burner does not light within 15 seconds, turn the knob off and wait at least one minute before trying again.
- 5 After use, always turn the knobs to the O (OFF) position.

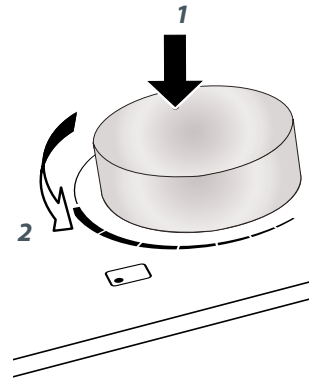

Fig. 14 Pressing down then turning the burner knob

Flame failure safety feature

The burners have a flame failure probe as well as an ignitor (see Fig 15). The flame failure probe cuts off the gas supply to the burner if the flame is blown out.

If the flames are accidentally extinguished, turn off the burner and do not try to light it again for at least one minute (to allow the gas to disperse).

If a burner does not light

Check that:

- the cooktop is plugged in and the electricity is switched on
- the gas is turned on
- the gas bottle is not empty (if you are using bottled gas)
- you have held down the knob for at least 10 seconds
- the ignitors are sparking. If the ignitors are not sparking, they may be dirty or wet. Clean them with a toothbrush and methylated spirits, as shown in Fig. 15.

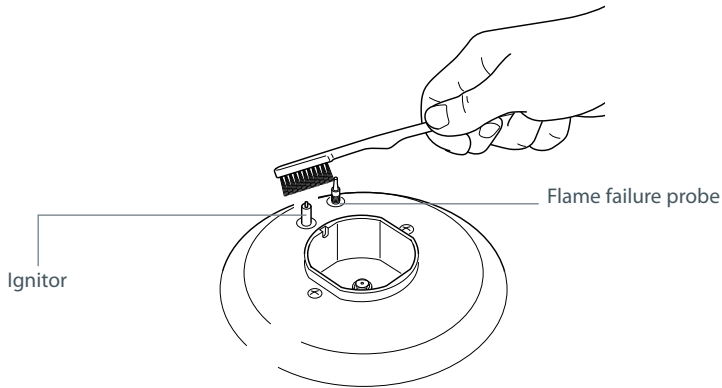

Fig.15 Cleaning the ignitor and probe

If the flame is irregular

If the flame is yellow or irregular, check that the burner parts, including the burner cap, are:

- clean and dry
- positioned correctly as shown in the 'Care and cleaning' section. See also 'Troubleshooting'.

Matching cookware to burner

Use flat-bottomed pans, and make sure they match the size of the burner, as shown in the following table. A small pot on a large burner is not efficient.

Diameters of pans which may be used on the cooktop

Burners	Minimum	Maximum
Auxiliary	12 cm	14 cm
Semi-rapid	16 cm	right front: 22 cm left rear: 24 cm
Rapid	24 cm	26 cm
Triple-ring wok	26 cm	28 cm
Maximum diameter for woks 36 cm		

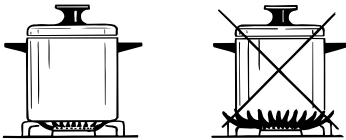

Fig. 16 Correct and incorrect matching of cookware and burner size



Fig. 17 Efficient and inefficient saucepan bottoms

Wok stand

The wok stand fits over the triple-ring wok burner pan support.

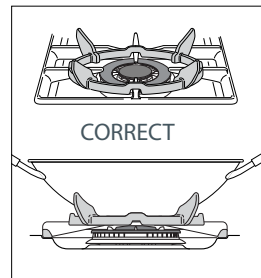
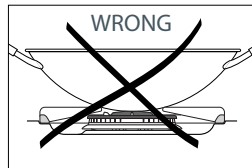

Fig. 18 Correct placement of wok stand

Important!

- Using a wok without the stand may cause the wok to tip or the wok burner to operate incorrectly.
- Do not use the stand for ordinary, flat-bottomed saucepans.
- The wok stand **MUST BE PLACED ONLY** over the pan support for the triple-ring wok burner.

Important!

Before any cleaning or maintenance, make sure that:

- all the burners are turned off
- the cooktop is disconnected from the power supply
- all parts of the cooktop are cool enough to safely touch.

General advice

- Clean the cooktop **after every use** – do not allow stains to become burnt on. See the cleaning chart following.
- Clean the burners and ignitors **at least once a month**. See the cleaning chart following.
- **Once every 3 or 4 years**, contact your local Authorised Service Centre and have all the gas components of your cooktop thoroughly checked, even if your cooktop is functioning correctly.
- Do not leave acidic substances (lemon juice, vinegar etc) on the surfaces.
- Do not use harsh, abrasive cleaners or unsuitable scourers, as these may damage the stainless steel surfaces.
- Do not clean cooktop parts in a self-cleaning oven.
- Do not use a steam cleaner to clean any part of your cooktop.

Cleaning chart

What?	Soiling examples	How?	Important!
Stainless steel base	<ul style="list-style-type: none"> ■ fingerprints ■ food stains ■ hard water spots 	<ul style="list-style-type: none"> ■ Soak stubborn stains under a hot soapy cloth, rinse and dry thoroughly. ■ Hard water spots can be removed with household white vinegar. ■ Use non-abrasive stainless steel cleaners. ■ Regular use of a stainless steel polish will reduce fingerprints and other marks. Follow the manufacturer's instructions. ■ Heavy soiling can be removed with fume free or heavy-duty oven cleaner. Follow the manufacturer's instructions. 	<ul style="list-style-type: none"> ■ <i>Never use harsh/abrasive cleaning agents and scourers as they will damage the stainless steel finish.</i> ■ <i>Chlorine compounds in some cleaners (eg bleaches) are corrosive to stainless steel and may damage its appearance.</i> ■ <i>The graphics are etched onto the steel by laser and will not rub off.</i>
Knobs	<ul style="list-style-type: none"> ■ fingerprints ■ food stains 	<ol style="list-style-type: none"> 1 Clean with hot soapy water. 2 Dry thoroughly with a soft cloth. 	
Pan supports, burner caps and ring	stains left by liquid spills or burnt-on food	<ol style="list-style-type: none"> 1 Remove parts, then soak to remove stubborn stains, then wash with hot soapy water. 2 Rinse, then dry with a soft cloth. 	<ul style="list-style-type: none"> ■ <i>Make sure you replace the burner parts correctly, as shown in the drawings following.</i> ■ <i>Do not use the burners without all its parts correctly in place.</i> ■ <i>Dry all burner parts thoroughly before replacing as even small droplets of water will affect the performance of a burner.</i>
Flame spreaders	soiling trapped in the holes and notches	<ol style="list-style-type: none"> 1 Use a stiff nylon brush or a straightened paper clip to clear the holes and notches. 2 Wash with hot soapy water. 3 Rinse and wipe dry. 	
Ignitor	food or liquid spills on these parts	Use a toothbrush and methylated spirits to clean these. See Fig. 15.	<i>A dirty or wet ignitor will prevent the burner from lighting efficiently.</i>
Flame failure probe			<i>A dirty probe may prevent the flame failure device from working effectively.</i>

Replacing the auxiliary, semi-rapid, and rapid burners

Ensure that the burner assembly is:

- unable to rotate
- stable and level
- correctly aligned.

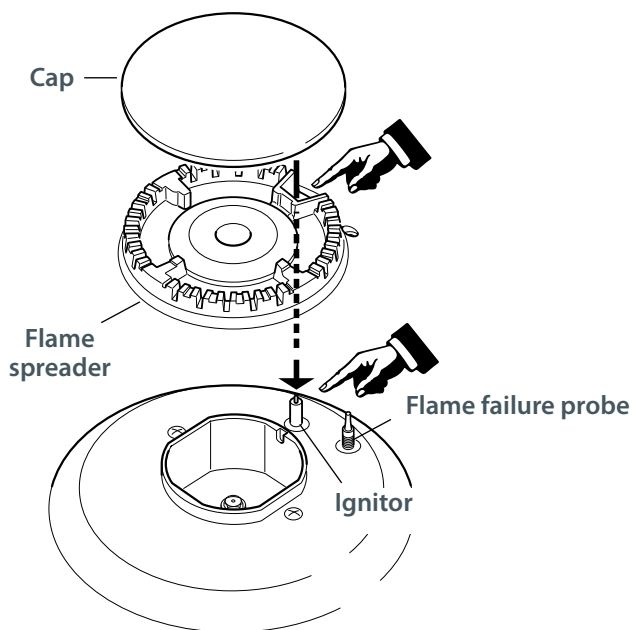

Fig. 19 Correct line-up of auxiliary, rapid and semi-rapid burner parts

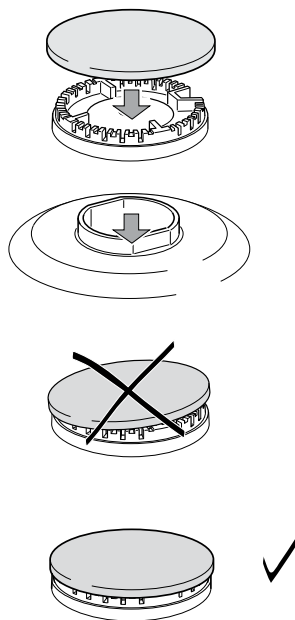

Fig. 20 Replacing the auxiliary, rapid and semi-rapid burner cap

Replacing the triple-ring wok burner

Ensure that the burner assembly is:

- unable to rotate
- stable and level
- correctly aligned.

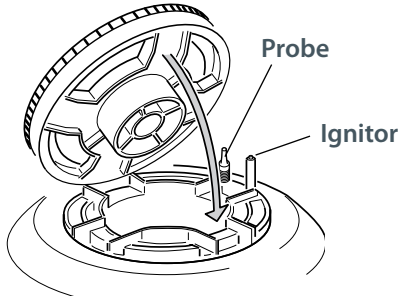

Fig. 21 Fitting the burner spreader to the housing.

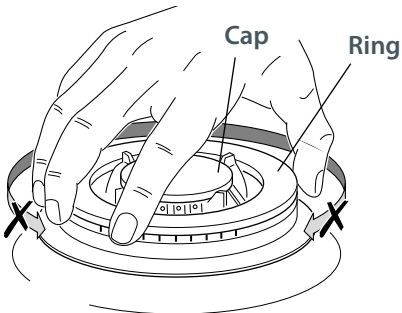

Fig. 22 Correct positioning of cap and ring - triple-ring wok burner

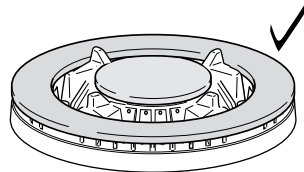
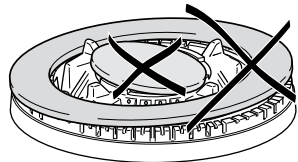
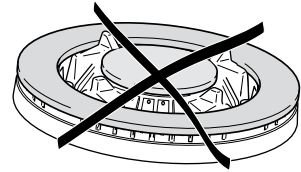

Fig. 23 Incorrect and correct positioning of cap and ring - triple-ring wok burner

Problem	Possible solutions
A burner does not light	<p>Check the cooktop is plugged in and the electricity is switched on. Check the gas supply valve is turned on and the supply to the house is working. You should hear the gas when you turn a burner on.</p> <p>If you use bottled gas, check the gas bottle is not empty. The ignitors may be dirty. Clean them with a toothbrush and methylated spirits.</p> <p>The burner parts may not be located properly. Check the assembly and make sure the burner cap is sitting flat.</p>
My burner flames are yellow or hard to start	<p>The burner parts may not be located properly. Check the assembly and make sure the burner cap is sitting flat.</p> <p>If you use bottled gas, this may indicate you are getting near the end of the bottle.</p> <p>Check the burner parts are clean and dry.</p> <p>The gas pressure may not be at the correct level. Check with your service person or installer.</p> <p>Your cooktop may not be set up for the gas you are using. Check this with your service person or installer.</p>
One of my burners has an uneven flame	<p>Check the burner parts are clean and dry. Check the assembly and make sure the burner cap is sitting flat.</p>
The flame goes out at low settings	<p>The gas supply pressure may be low. Check this with your service person or installer.</p> <p>The low setting may have been adjusted incorrectly. Check this with your service person or installer.</p> <p>If you use bottled gas, this may indicate you are getting near the end of the bottle.</p>
My burners do not turn down much (when running on bottled gas or LPG)	<p>Your cooktop may not have been adjusted correctly. Check this with your service person or installer.</p>
The flame tips are very yellow	<p>Call your service person to service the cooktop.</p>
There are objectionable odours	<p>Call your service person to service the cooktop.</p>
The flame appears to lift off the burner	<p>Call your service person to service the cooktop.</p>
There is an electricity failure	<p>If there is an electricity failure, you can still use your cooktop. Light the burners by holding a match close to the side of the burner and turning the knob to the Maximum position. Wait until the flame is burning evenly before adjusting.</p>

Before you call for service or assistance ...

Check the things you can do yourself. Refer to the installation instructions and your user guide and check that:

- 1 your product is correctly installed
- 2 you are familiar with its normal operation.

If after checking these points you still need assistance, please refer to the Service & Warranty book for warranty and after-sales service details or contact us through our local website listed on the back cover.

This cooktop has been designed and constructed in accordance with the following codes and specifications:

Safety requirements of EEC Directive "Gas" 90/396

- EN 30-1-1
- EN 30-2-1
- EN 437

Safety requirements of EEC Directive "Low voltage" 2006/95:

- EN 60335-1 General Requirements for Domestic electrical appliances
- EN 60335-2-6 Particular Requirements for Domestic electrical cooking appliances

Safety requirements of EEC Directive "EMC" 89/336:

- EN 55014-1, EN 55014-2, EN 61000-3-2, EN 61000-3-3 Electromagnetic Compatibility Requirements

Requirements of EEC Directive 93/68

Product details

Fisher & Paykel Ltd

Model _____ Serial no. _____

Date of purchase _____ Purchaser _____

Dealer _____ Suburb _____

Town _____ Country _____

Copyright © Fisher & Paykel 2008. All rights reserved.

The product specifications in this booklet apply to the specific products and models described at the date of issue. Under our policy of continuous product improvement, these specifications may change at any time. You should therefore check with your Dealer to ensure this booklet correctly describes the product currently available.

www.fisherpaykel.co.uk
www.fisherpaykel.ie

GB IE

Gas cooktop installation and user guide

Published: 09/2008

F&P Part No. 599584 A

F&P Italy Part No. 1103205 - B1