

**CHICAGO  ELECTRIC<sup>®</sup>**  
**POWER TOOLS**

# 1/2" HAMMER DRILL

**Model 68169**

## SET UP AND OPERATING INSTRUCTIONS



Visit our website at: <http://www.harborfreight.com>



**Read this material before using this product.  
Failure to do so can result in serious injury.  
SAVE THIS MANUAL.**

---

Copyright© 2010 by Harbor Freight Tools®. All rights reserved. No portion of this manual or any artwork contained herein may be reproduced in any shape or form without the express written consent of Harbor Freight Tools. Diagrams within this manual may not be drawn proportionally. Due to continuing improvements, actual product may differ slightly from the product described herein. Tools required for assembly and service may not be included.

**For technical questions or replacement parts, please call 1-800-444-3353.**

---

## SAVE THIS MANUAL

---

Keep this manual for the safety warnings and precautions, assembly, operating, inspection, maintenance and cleaning procedures. Write the product's serial number in the back of the manual near the assembly diagram (or month and year of purchase if product has no number). Keep this manual and the receipt in a safe and dry place for future reference.

---

## IMPORTANT SAFETY INFORMATION

---

In this manual, on the labeling, and all other information provided with this product:



This is the safety alert symbol. It is used to alert you to potential personal injury hazards. Obey all safety messages that follow this symbol to avoid possible injury or death.

### **DANGER**

**DANGER** indicates a hazardous situation which, if not avoided, will result in death or serious injury.

### **WARNING**

**WARNING** indicates a hazardous situation which, if not avoided, could result in death or serious injury.

### **CAUTION**

**CAUTION**, used with the safety alert symbol, indicates a hazardous situation which, if not avoided, could result in minor or moderate injury.

### **NOTICE**

**NOTICE** is used to address practices not related to personal injury.

### **CAUTION**

**CAUTION**, without the safety alert symbol, is used to address practices not related to personal injury.

---

## General Power Tool Safety Warnings

---



**WARNING** Read all safety warnings and instructions. *Failure to follow the warnings and instructions may result in electric shock, fire and/or serious injury.*

**Save all warnings and instructions for future reference.**

*The term "power tool" in the warnings refers to your mains-operated (corded) power tool or battery-operated (cordless) power tool.*

1. **Work area safety**
  - a. **Keep work area clean and well lit.** *Cluttered or dark areas invite accidents.*
  - b. **Do not operate power tools in explosive atmospheres, such as in the presence of flammable liquids, gases or dust.** *Power tools create sparks which may ignite the dust or fumes.*
  - c. **Keep children and bystanders away while operating a power tool.** *Distractions can cause you to lose control.*
2. **Electrical safety**
  - a. **Power tool plugs must match the outlet. Never modify the plug in any way. Do not use any adapter plugs with grounded power tools.** *Unmodified plugs and matching outlets will reduce risk of electric shock.*
  - b. **Avoid body contact with grounded surfaces such as pipes, radiators,**

**ranges and refrigerators.** *There is an increased risk of electric shock if your body is grounded.*

- c. **Do not expose power tools to rain or wet conditions.** *Water entering a power tool will increase the risk of electric shock.*
  - d. **Do not abuse the cord. Never use the cord for carrying, pulling or unplugging the power tool. Keep cord away from heat, oil, sharp edges or moving parts.** *Damaged or entangled cords increase the risk of electric shock.*
  - e. **When operating a power tool outdoors, use an extension cord suitable for outdoor use.** *Use of a cord suitable for outdoor use reduces the risk of electric shock.*
  - f. **If operating a power tool in a damp location is unavoidable, use a Ground Fault Circuit Interrupter (GFCI) protected supply.** *Use of a GFCI reduces the risk of electric shock.*
3. **Personal safety**
- a. **Stay alert, watch what you are doing and use common sense when operating a power tool. Do not use a power tool while you are tired or under the influence of drugs, alcohol or medication.** *A moment of inattention while operating power tools may result in serious personal injury.*
  - b. **Use personal protective equipment. Always wear eye protection.** *Safety equipment such as dust mask, non-skid safety shoes, hard hat, or hearing protection used for appropriate conditions will reduce personal injuries.*
  - c. **Prevent unintentional starting. Ensure the switch is in the off-position before connecting to power source and/or battery pack, picking up or carrying the tool.** *Carrying power tools with your finger on the switch or energizing power tools that have the switch on invites accidents.*
- d. **Remove any adjusting key or wrench before turning the power tool on.** *A wrench or a key left attached to a rotating part of the power tool may result in personal injury.*
  - e. **Do not overreach. Keep proper footing and balance at all times.** *This enables better control of the power tool in unexpected situations.*
  - f. **Dress properly. Do not wear loose clothing or jewelry. Keep your hair, clothing and gloves away from moving parts.** *Loose clothes, jewelry or long hair can be caught in moving parts.*
  - g. **If devices are provided for the connection of dust extraction and collection facilities, ensure these are connected and properly used.** *Use of these devices can reduce dust-related hazards.*
  - h. **Only use safety equipment that has been approved by an appropriate standards agency.** *Unapproved safety equipment may not provide adequate protection. Eye protection must be ANSI-approved and breathing protection must be NIOSH-approved for the specific hazards in the work area.*
4. **Power tool use and care**
- a. **Do not force the power tool. Use the correct power tool for your application.** *The correct power tool will do the job better and safer at the rate for which it was designed.*
  - b. **Do not use the power tool if the switch does not turn it on and off.** *Any power tool that cannot be controlled*

*with the switch is dangerous and must be repaired.*

- c. **Disconnect the plug from the power source and/or the battery pack from the power tool before making any adjustments, changing accessories, or storing power tools.** *Such preventive safety measures reduce the risk of starting the power tool accidentally.*
  - d. **Store idle power tools out of the reach of children and do not allow persons unfamiliar with the power tool or these instructions to operate the power tool.** *Power tools are dangerous in the hands of untrained users.*
  - e. **Maintain power tools. Check for misalignment or binding of moving parts, breakage of parts and any other condition that may affect the power tool's operation. If damaged, have the power tool repaired before use.** *Many accidents are caused by poorly maintained power tools.*
  - f. **Keep cutting tools sharp and clean.** *Properly maintained cutting tools with sharp cutting edges are less likely to bind and are easier to control.*
  - g. **Use the power tool, accessories and tool bits etc. in accordance with these instructions, taking into account the working conditions and the work to be performed.** *Use of the power tool for operations different from those intended could result in a hazardous situation.*
5. **Service**
- a. **Have your power tool serviced by a qualified repair person using only identical replacement parts.** *This will ensure that the safety of the power tool is maintained.*

## **Drill and Impact Drill Safety Warnings**

1. **Wear ear protectors with impact drills.** *Exposure to noise can cause hearing loss.*
2. **Use Auxiliary Handle (4) supplied with the Drill.** *Loss of control can cause personal injury.*
3. **Hold power tools by insulated gripping surfaces when performing an operation where the cutting tool may contact hidden wiring or its own cord.** *Contact with a "live" wire will make exposed metal parts of the tool "live" and shock the operator.*
4. Maintain labels and nameplates on the tool. These carry important safety information. If unreadable or missing, contact Harbor Freight Tools for a replacement.
5. Avoid unintentional starting. Prepare to begin work before turning on the tool.
6. Do not lay the tool down until it has come to a complete stop. Moving parts can grab the surface and pull the tool out of your control.
7. When using a handheld power tool, maintain a firm grip on the tool with both hands to resist starting torque.
8. Do not leave the tool unattended when it is plugged into an electrical outlet. Turn off the tool, and unplug it from its electrical outlet before leaving.
9. This product is not a toy. Keep it out of reach of children.
10. People with pacemakers should consult their physician(s) before use. Electromagnetic fields in close proximity to heart pacemaker could cause

pacemaker interference or pacemaker failure. In addition, people with pacemakers should:

- Avoid operating alone.
- Do not use with power switch locked on.
- Properly maintain and inspect to avoid electrical shock.
- Any power cord must be properly grounded. Ground Fault Circuit Interrupter (GFCI) should also be implemented – it prevents sustained electrical shock.

11. **WARNING:** Some dust created by power sanding, sawing, grinding, drilling, and other construction activities, contains chemicals known [to the State of California] to cause cancer, birth defects or other reproductive harm. Some examples of these chemicals are:
- Lead from lead-based paints
  - Crystalline silica from bricks and cement or other masonry products
  - Arsenic and chromium from chemically treated lumber
- Your risk from these exposures varies, depending on how often you do this type of work. To reduce your exposure to these chemicals: work in a well ventilated area, and work with approved safety equipment, such as those dust masks that are specially designed to filter out microscopic particles. (California Health & Safety Code § 25249.5, *et seq.*)
12. **WARNING:** Handling the cord on this product will expose you to lead, a chemical known to the State of California to cause cancer, and birth defects or other reproductive harm. Wash hands after handling. (California Health & Safety Code § 25249.5, *et seq.*)
13. The warnings, precautions, and instructions discussed in this instruction manual cannot cover all possible

conditions and situations that may occur. It must be understood by the operator that common sense and caution are factors which cannot be built into this product, but must be supplied by the operator.

### **Vibration Safety**

This tool vibrates during use. Repeated or long-term exposure to vibration may cause temporary or permanent physical injury, particularly to the hands, arms and shoulders. To reduce the risk of vibration-related injury:

1. Anyone using vibrating tools regularly or for an extended period should first be examined by a doctor and then have regular medical check-ups to ensure medical problems are not being caused or worsened from use. Pregnant women or people who have impaired blood circulation to the hand, past hand injuries, nervous system disorders, diabetes, or Raynaud's Disease should not use this tool. If you feel any symptoms related to vibration (such as tingling, numbness, and white or blue fingers), seek medical advice as soon as possible.
2. Do not smoke during use. Nicotine reduces the blood supply to the hands and fingers, increasing the risk of vibration-related injury.
3. Wear suitable gloves to reduce the vibration effects on the user.
4. Use tools with the lowest vibration when there is a choice.
5. Include vibration-free periods each day of work.
6. Grip tool as lightly as possible (while still keeping safe control of it). Let the tool do the work.

- To reduce vibration, maintain the tool as explained in this manual. If any abnormal vibration occurs, stop use immediately.



## SAVE THESE INSTRUCTIONS.

---

### GROUNDING

---

#### **WARNING** TO PREVENT ELECTRIC SHOCK

#### AND DEATH FROM INCORRECT GROUNDING WIRE CONNECTION:



Check with a qualified electrician if you are in doubt as to whether the outlet is properly grounded. Do not modify the power cord plug provided with the tool. Never remove the grounding prong from the plug. Do not use the tool if the power cord or plug is damaged. If damaged, have it repaired by a service facility before use. If the plug will not fit the outlet, have a proper outlet installed by a qualified electrician.

---

#### Double Insulated Tools: Tools with Two Prong Plugs

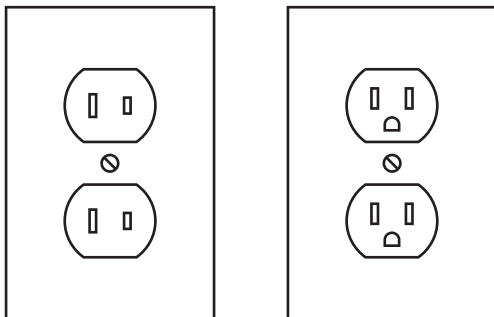

Outlets for 2-Prong Plug

- Tools marked “Double Insulated” do not require grounding. They have a special double insulation system which satisfies OSHA requirements and complies with the applicable standards of Underwriters Laboratories, Inc., the Canadian Standard Association, and the National Electrical Code.
- Double insulated tools may be used in either of the 120 volt outlets shown in the preceding illustration. **(See Outlets for 2-Prong Plug.)**

#### Extension Cords







- Grounded** tools require a three wire extension cord. **Double Insulated** tools can use either a two or three wire extension cord.
- As the distance from the supply outlet increases, you must use a heavier gauge extension cord. Using extension cords with inadequately sized wire causes a serious drop in voltage, resulting in loss of power and possible tool damage. **(See Table A.)**
- The smaller the gauge number of the wire, the greater the capacity of the cord. For example, a 14 gauge cord can carry a higher current than a 16 gauge cord. **(See Table A.)**
- When using more than one extension cord to make up the total length, make sure each cord contains at least the minimum wire size required. **(See Table A.)**
- If you are using one extension cord for more than one tool, add the nameplate amperes and use the sum to determine the required minimum cord size. **(See Table A.)**

6. If you are using an extension cord outdoors, make sure it is marked with the suffix “W-A” (“W” in Canada) to indicate it is acceptable for outdoor use.
7. Make sure the extension cord is properly wired and in good electrical condition. Always replace a damaged extension cord or have it repaired by a qualified electrician before using it.
8. Protect the extension cords from sharp objects, excessive heat, and damp or wet areas.

<b>RECOMMENDED MINIMUM WIRE GAUGE FOR EXTENSION CORDS* (120/240 VOLT)</b>					
<b>NAMEPLATE AMPERES (at full load)</b>	<b>EXTENSION CORD LENGTH</b>				
	<b>25'</b>	<b>50'</b>	<b>75'</b>	<b>100'</b>	<b>150'</b>
0 – 2.0	18	18	18	18	16
2.1 – 3.4	18	18	18	16	14
3.5 – 5.0	18	18	16	14	12
5.1 – 7.0	18	16	14	12	12
7.1 – 12.0	18	14	12	10	-
12.1 – 16.0	14	12	10	-	-
16.1 – 20.0	12	10	-	-	-

**TABLE A** \* Based on limiting the line voltage drop to five volts at 150% of the rated amperes.

### Symbology

	Double Insulated
	Canadian Standards Association
	Underwriters Laboratories, Inc.
	Volts Alternating Current
	Amperes
	No Load Revolutions per Minute (RPM)

## SPECIFICATIONS

Electrical Input	120 V~ / 60 Hz / 7.5 A (Rated)
Motor Speed	0-2800 RPM
Drilling Capacity	1/2" in Steel 5/8" in Masonry 1" in Wood (Hammer Drill and Drill mode)
Chuck Capacity	1/16" to 1/2" Three Jaw Key Type

## UNPACKING

When unpacking, make sure that the item is intact and undamaged. If any parts are missing or broken, please call Harbor Freight Tools at 1-800-444-3353 as soon as possible.

## INSTRUCTIONS FOR PUTTING INTO USE



Read the **ENTIRE IMPORTANT SAFETY INFORMATION** section at the beginning of this manual including all text under subheadings therein before set up or use of this product.

### **!WARNING**

**TO PREVENT SERIOUS INJURY**

**FROM ACCIDENTAL OPERATION:** Turn the Trigger (32) off and unplug the tool from its electrical outlet before assembling or making any adjustments to the tool.

**Note:** For additional information regarding the parts listed in the following pages, refer to the Assembly Diagram near the end of this manual.

## Assembly

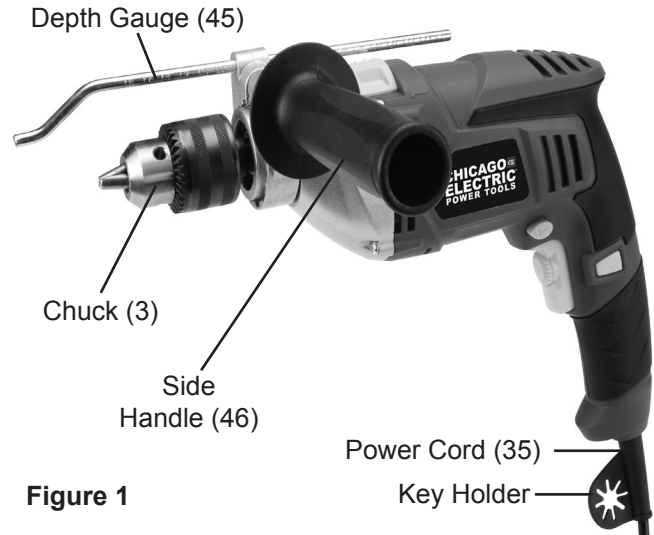

Figure 1

1. Loosen the grip on the Side Handle (46) and slide Side Handle clamp over and behind the Chuck (3) until it is set against housing.
2. Rotate the Side Handle until it is in desired orientation. If you are right-handed, position the Side Handle so it extends from the left of the housing, as shown Figure 1 above.
3. Rotate Side Handle clockwise to secure the clamp.
4. To install the Depth Gauge (45), loosen the Side Handle and slide the Depth Gauge into the gauge hole. See Figure 1, above.
5. Set Depth Gauge to required depth and retighten grip to fasten Depth Gauge into place (read further explanation under General Operating Instructions).



## OPERATING INSTRUCTIONS



Read the **ENTIRE IMPORTANT SAFETY INFORMATION** section at the beginning of this manual including all text under subheadings therein before set up or use of this product.

### Tool Set Up



**TO PREVENT SERIOUS INJURY**

**FROM ACCIDENTAL OPERATION:** Turn Tool off, unplug from its electrical outlet and remove Drill Chuck Key before adjusting tool or installing accessories.

The Hammer Drill is equipped with a keyed Chuck. Follow these steps to insert bit:

1. Insert Chuck Key (2) into the Chuck and turn counterclockwise to open the Chuck.
2. Insert the hammer bit or the drill bit (not included) all the way into the Chuck.
3. Turn the Chuck Key clockwise to tighten the Chuck on the bit. When not in use, the Key can be stored in the key holder on the Power Cord (35).

### Work Piece and Work Area Set Up

1. Designate a work area that is clean and well-lit. The work area must not allow access by children or pets to prevent distraction and injury.
2. Route the power cord along a safe path to reach the work area without creating a tripping hazard or exposing the power cord to possible damage. The power cord must reach the work area with enough extra length to allow free movement while working.

3. If possible, secure loose work pieces using a vise or clamps (not included) to prevent movement while working, if possible.
4. There must not be objects, such as utility lines, nearby that will present a hazard while working.

### General Operating Instructions

1. Plug Power Cord into a working outlet.
2. Set Direction Switch (40) to correct position. For clockwise (forward) rotation, push it from left side (Switch surface is marked with "R"). See Figure 2, below.
3. To rotate Chuck in a counterclockwise (reverse) direction, push it from the left side (Switch surface is marked with "L").

**WARNING! Do not change rotation direction while the Chuck is rotating.**

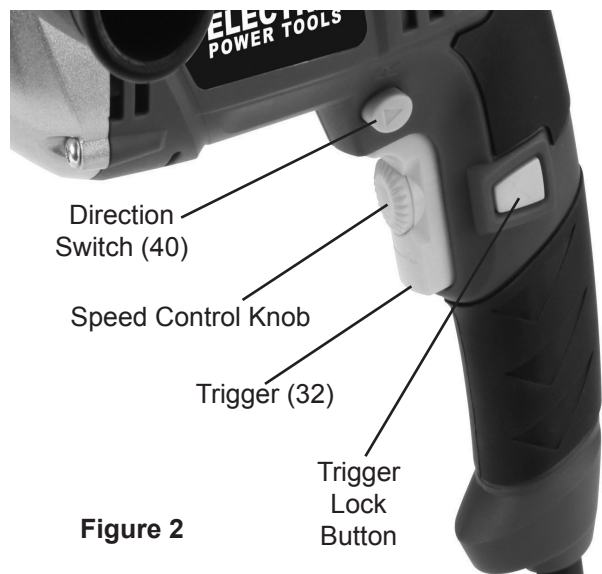

**Figure 2**

4. Verify bit is securely locked in Chuck.
5. Press Trigger to activate. Observe rotating bit, making sure it does not wobble. If it does, back off Chuck and reposition the bit.

6. To adjust the drilling speed, rotate the speed control knob located in the center of the Trigger. Turn clockwise to increase speed and counterclockwise to decrease speed. See Figure 2.
7. For continuous drilling, press Trigger, then Trigger lock button on side of handle, and release Trigger. To release lock, depress Trigger. See Figure 2.
8. **WARNING!** Use both hands during use.
9. Use the Depth Gauge for controlled depth drilling. The Depth Gauge has two sets of markings on opposite ends of the gauge. One is in half inch increments and the other in one-centimeter increments (increments are not precise values, only general guides).
10. Insert bit and tighten Chuck. Loosen Side Handle, place tip of bit against solid surface and extend Depth Gauge until it is against same surface. Determine required hole-depth and retract Gauge accordingly. Tighten Side Handle.
11. To switch between plain drilling and hammering mode (drilling with an oscillating hammer motion), slide the Mode Selector (26) to left or right. The “drill” symbol indicates plain drilling while the “hammer” symbol indicates hammer drilling. See Figure 3.

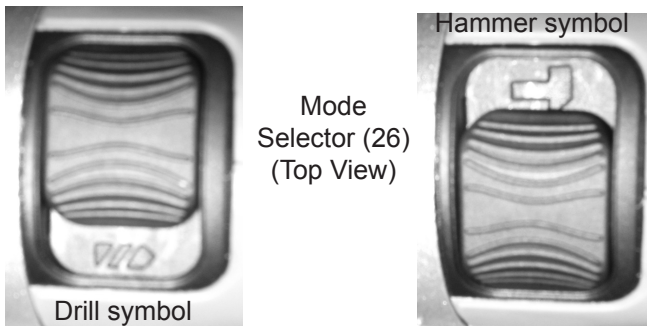

Figure 3

12. **WARNING! Use this continuous drill function ONLY when drilling soft**

**materials. Do not drill or hammer drill hard materials such as steel or concrete with Lock Button pressed (ON).** If drill bit catches on material, the high torque will cause the tool to twist around without stopping. This violent action could cause injury to your hands and arms. It could also damage the Hammer Drill.

13. To prevent accidents, turn off the tool and disconnect its power supply after use. Clean, then store the tool indoors out of children’s reach.

### Metal Drilling Tips

1. Use high speed steel, carbide or specialty bits for metal drilling.
2. Secure work piece to keep it from moving during the drilling operation.
3. Use a center punch (not included) to create a dimple for the bit to start.
4. Remove Key from Chuck.
5. Start by drilling slowly to keep bit from wandering/skating away from your starting point.
6. As hole is established, increase speed. Do not use so much pressure that bit heats up. This can damage bit and create irregular hole. For hard metal, use cutting oil to keep bit cool.
7. When drilling large holes in metal, start by drilling a smaller pilot hole, then using a larger bit for the final size hole.

### Wood Drilling Tips

1. Use high speed bits or bits specially designed for wood drilling, such as brad point, spade bits, forstner bits, etc.
2. Secure work piece to keep it from moving during the drilling operation.

3. Start by drilling slowly to keep bit from wandering away from starting point. Increase speed as hole is established.
4. To prevent or reduce “break out” when bit penetrates work piece, clamp a piece of scrap material to back of work piece.
5. Do not lock Trigger in the ON position, as the bit can easily jam in wood and motor must be stopped quickly.

### Concrete Drilling Tips

1. Use carbide or specialty bits for concrete drilling.
2. Rock and masonry are generally drilled in the hammer (impact) drilling mode.
3. When drilling in walls, start with regular drilling and, once tile is pierced, continue with hammer mode.

**NOTE:** In deep bore holes, occasionally pull the drill bit out to remove dust and chips.

### Recommended Drill Bits Sets

The chart below lists applicable Drill Bit sets that are available from Harbor Freight Tools.

SKU	Name	To Drill Into	Sizes
32925	29-Piece High Speed Steel Drill Bit Set	Metals	1/16" to 1/2" by 64ths
40547	20-Piece 1/8" Shank Diamond Point Set	Metals, Glass	1-3/4" overall length
1637	7-Piece Brad Point Wood Bit Set	Wood	3" to 6" Length; Sizes: 1/8", 3/16", 1/4", 5/16", 3/8", 7/16", and 1/2" bits
33449	3-Piece 25" Long Wood Bit Set	Wood	5/16", 3/8", 7/16"
35837	29-Piece Brad Point Wood Drill Bit Set	Wood	Sizes: 1/16" through 1/2" by 64ths
42256	5-Piece Quick Change Masonry Drill Bits	Concrete/Masonry	5/32", 3/16", 1/4", 5/16" and 3/8"
46754	5-Piece 12" SDS Masonry Bit Set	Concrete/Masonry	5/16", 3/8", 1/2", 3/4", and 1"
46755	5-Piece 16" SDS Masonry Bit Set	Concrete/Masonry	5/16", 3/8", 1/2", 3/4", 1"

---

## MAINTENANCE AND SERVICING

---



Procedures not specifically explained in this manual must be performed only by a qualified technician.

### **!WARNING**

#### TO PREVENT SERIOUS INJURY

**FROM ACCIDENTAL OPERATION:** Turn the Trigger off and unplug the tool from its electrical outlet before performing any inspection, maintenance, or any cleaning procedures.

#### TO PREVENT SERIOUS INJURY FROM TOOL FAILURE:

Do not use damaged equipment. If abnormal noise or vibration occurs, have the problem corrected before further use.

---

### **Cleaning, Maintenance, and Lubrication**

1. **BEFORE EACH USE**, inspect the general condition of the tool. Check for loose hardware, misalignment or binding of moving parts, cracked or broken parts, damaged electrical wiring, and any other condition that may affect its safe operation.
2. **AFTER USE**, wipe the tool with a clean cloth.
3. **PERIODICALLY**, and after each prolonged and extensive application, blow compressed air into the motor housing slots to remove any accumulated dirt and debris.

**!WARNING!** If the supply cord of this power tool is damaged, it must be replaced only by a qualified service technician.

## Troubleshooting

Problem	Possible Causes	Likely Solutions
Tool will not start.	<ol style="list-style-type: none"> <li>1. Cord not connected.</li> <li>2. No power at outlet.</li> <li>3. Internal damage or wear. (Carbon brushes or switch.)</li> </ol>	<ol style="list-style-type: none"> <li>1. Check that cord is plugged in.</li> <li>2. Check power at outlet. If outlet is unpowered, turn off tool and check circuit breaker. If breaker is tripped, make sure circuit is right capacity for tool and circuit has no other loads.</li> <li>3. Have technician service tool.</li> </ol>
Tool operates slowly.	Extension cord too long or wire size too small.	Eliminate use of extension cord. If an extension cord is needed, use shorter/heavier gauge cord. See <i>Extension Cords</i> in <i>GROUNDING</i> section.
Performance decreases over time.	<ol style="list-style-type: none"> <li>1. Accessory dull or damaged.</li> <li>2. Carbon brushes worn or damaged.</li> </ol>	<ol style="list-style-type: none"> <li>1. Keep cutting accessories sharp. Replace as needed.</li> <li>2. Have qualified technician replace brushes.</li> </ol>
Excessive noise or rattling.	Internal damage or wear. (Carbon brushes or bearings, for example.)	Have technician service tool.
Overheating.	<ol style="list-style-type: none"> <li>1. Forcing tool to work too fast.</li> <li>2. Bit dull or damaged.</li> <li>3. Blocked motor housing vents.</li> <li>4. Motor being strained by long or small diameter extension cord.</li> <li>5. Improper internal parts lubrication.</li> </ol>	<ol style="list-style-type: none"> <li>1. Allow tool to work at its own rate.</li> <li>2. Keep bit sharp. Replace as needed.</li> <li>3. Wear ANSI-approved safety goggles and NIOSH-approved dust mask/respirator while blowing dust out of motor using compressed air.</li> <li>4. Eliminate use of extension cord. If an extension cord is needed, use one with the proper diameter for its length and load. See <i>Extension Cords</i> in <i>GROUNDING</i> section.</li> <li>5. Have a qualified technician service the tool using ONLY white lithium grease.</li> </ol>
 <b>Follow all safety precautions whenever diagnosing or servicing the tool. Disconnect power supply before service.</b>		

## PLEASE READ THE FOLLOWING CAREFULLY

THE MANUFACTURER AND/OR DISTRIBUTOR HAS PROVIDED THE PARTS LIST AND ASSEMBLY DIAGRAM IN THIS MANUAL AS A REFERENCE TOOL ONLY. NEITHER THE MANUFACTURER OR DISTRIBUTOR MAKES ANY REPRESENTATION OR WARRANTY OF ANY KIND TO THE BUYER THAT HE OR SHE IS QUALIFIED TO MAKE ANY REPAIRS TO THE PRODUCT, OR THAT HE OR SHE IS QUALIFIED TO REPLACE ANY PARTS OF THE PRODUCT. IN FACT, THE MANUFACTURER AND/OR DISTRIBUTOR EXPRESSLY STATES THAT ALL REPAIRS AND PARTS REPLACEMENTS SHOULD BE UNDERTAKEN BY CERTIFIED AND LICENSED TECHNICIANS, AND NOT BY THE BUYER. THE BUYER ASSUMES ALL RISK AND LIABILITY ARISING OUT OF HIS OR HER REPAIRS TO THE ORIGINAL PRODUCT OR REPLACEMENT PARTS THERETO, OR ARISING OUT OF HIS OR HER INSTALLATION OF REPLACEMENT PARTS THERETO.

## PARTS LIST

Part	Description	Qty.	Part	Description	Qty.
1	Screw (M6x25)	1	24	Spring Cap	1
2	Chuck Key	1	25	Spring	1
3	Chuck	1	26	Mode Selector	1
4	Spindle	1	27	Bearing (607)	1
5	Spindle Key (3x10mm)	1	28	Stator	1
6	Circlip (M23)	1	29	Housing	1
7	Bearing (6002)	1	30	O-Ring	1
8	Front Gear	1	31	Inductor	1
9	Back Gear	1	32	Trigger	1
10	Gear box	1	33	Cord Clamp	1
11	Screw (ST4x20)	4	34	Screw (ST4x14)	2
12	Circlip (M22)	1	35	Power Cord	1
13	Oil Seal	1	36	Cord Sleeve	1
14	Inner Gear	1	37	Screw (ST2.9x12)	4
15	Circlip (M12)	1	38	Carbon Brush	2
16	Spring	1	39	Brush Holder	2
17	Seal Ring	1	40	Direction Switch	1
18	Oil Seal	1	41	Capacitor	1
19	Support	1	42	Screw (ST4x22)	1
20	Bearing (608)	1	43	Housing	1
21	Rotor	1	44	Screw (ST4.2x16)	6
22	Bearing (607)	1	45	Depth Gauge	1
23	Impact Selector	1	46	Side Handle	1

**Record Product's Serial Number Here:** \_\_\_\_\_

**Note:** If product has no serial number, record month and year of purchase instead.

**Note:** Some parts are listed and shown for illustration purposes only, and are not available individually as replacement parts.

**ASSEMBLY DIAGRAM**

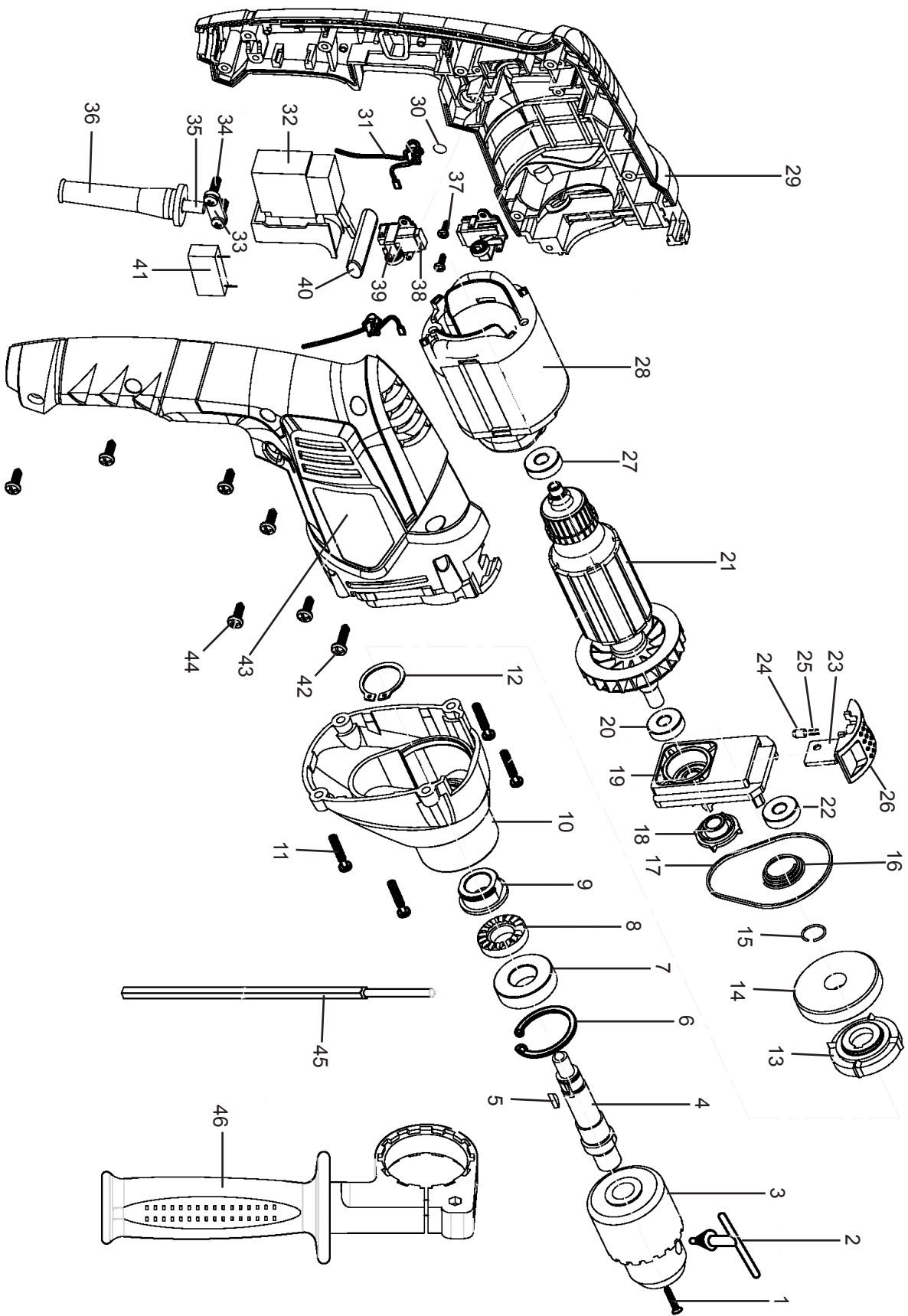

---

## LIMITED 90 DAY WARRANTY

---

Harbor Freight Tools Co. makes every effort to assure that its products meet high quality and durability standards, and warrants to the original purchaser that this product is free from defects in materials and workmanship for the period of 90 days from the date of purchase. This warranty does not apply to damage due directly or indirectly, to misuse, abuse, negligence or accidents, repairs or alterations outside our facilities, criminal activity, improper installation, normal wear and tear, or to lack of maintenance. We shall in no event be liable for death, injuries to persons or property, or for incidental, contingent, special or consequential damages arising from the use of our product. Some states do not allow the exclusion or limitation of incidental or consequential damages, so the above limitation of exclusion may not apply to you. THIS WARRANTY IS EXPRESSLY IN LIEU OF ALL OTHER WARRANTIES, EXPRESS OR IMPLIED, INCLUDING THE WARRANTIES OF MERCHANTABILITY AND FITNESS.

To take advantage of this warranty, the product or part must be returned to us with transportation charges prepaid. Proof of purchase date and an explanation of the complaint must accompany the merchandise. If our inspection verifies the defect, we will either repair or replace the product at our election or we may elect to refund the purchase price if we cannot readily and quickly provide you with a replacement. We will return repaired products at our expense, but if we determine there is no defect, or that the defect resulted from causes not within the scope of our warranty, then you must bear the cost of returning the product.

This warranty gives you specific legal rights and you may also have other rights which vary from state to state.

**3491 Mission Oaks Blvd. • PO Box 6009 Camarillo, CA 93011 • (800) 444-3353**