



Libero Line Series Infrared Cooktop

ITEM # _____

MODEL # _____

PROJECT NAME # _____

SIS # _____

AIA # _____

Electrolux

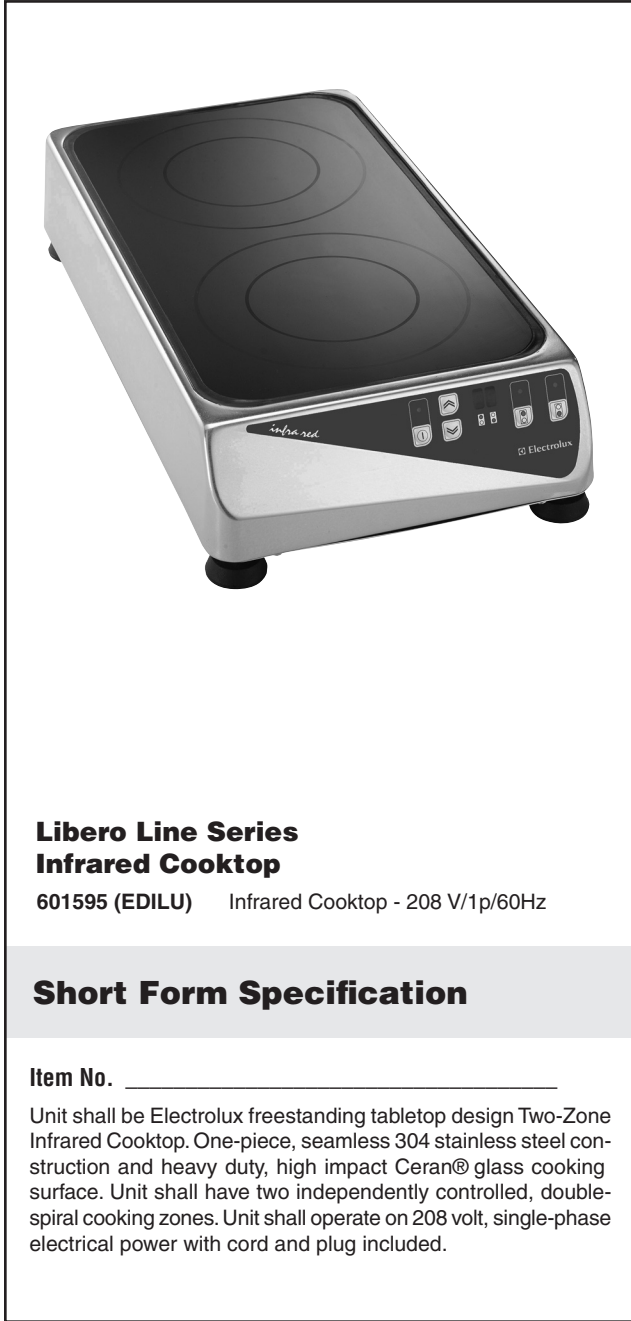

Libero Line Series Infrared Cooktop

601595 (EDILU) Infrared Cooktop - 208 V/1p/60Hz

Short Form Specification

Item No. _____

Unit shall be Electrolux freestanding tabletop design Two-Zone Infrared Cooktop. One-piece, seamless 304 stainless steel construction and heavy duty, high impact Ceran® glass cooking surface. Unit shall have two independently controlled, double-spiral cooking zones. Unit shall operate on 208 volt, single-phase electrical power with cord and plug included.

Main features

- Tabletop design, front-to-back model.
- Heavy duty, one-piece seamless, 304 AISI stainless steel construction.
- High impact, heavy duty Ceran® glass cooking surface for durability and easy cleaning.
- Two infrared, double spiral cooking zones (1.5 kW each) with independent touch button controls.
- Smooth rounded edges guarantee a flush fit between units.
- Diameter/size of cooking zones 8.6"
- Digital power level display and touch button control panel.
- IPX4 water protection.
- Cord and plug included.
- Installed electric power: 3 kW.
- External dimensions:
 - Height: 5.2"
 - Depth: 23.6"
 - Width: 12.8"
- ETL electrical and sanitation listed.
- NEMA # : 6-20P.
- Shipping weight – 31 lbs.
- Net weight – 29 lbs.
- 2 year parts warranty, 1 year labor.



NEMA #: 6-20P

Approval: _____

Electrolux Professional, Inc.
www.electroluxusa.com/professional

3225 SW 42nd Street, Fort Lauderdale, Florida, 33312 • Telephone Number: 866-449-4200 • Fax Number: 954-327-6789

Libero Line Series
Infrared Cooktop

Electric

Supply voltage:

601595 (EDILU) 208 V/1p/60Hz - 13.8A

Front View

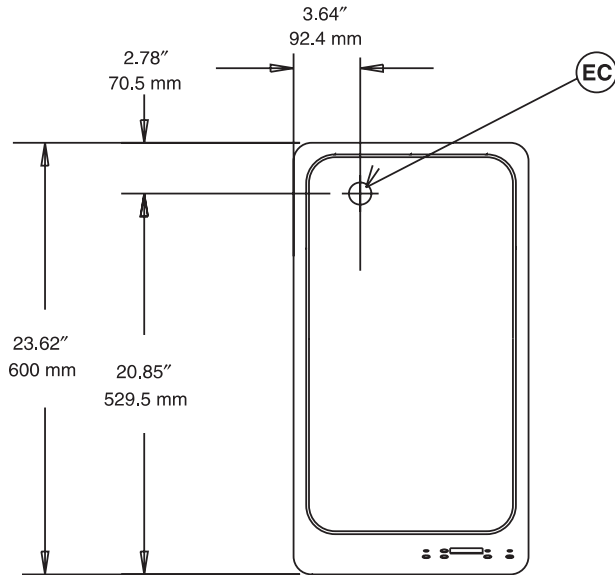

EC = Electrical connection

Top View

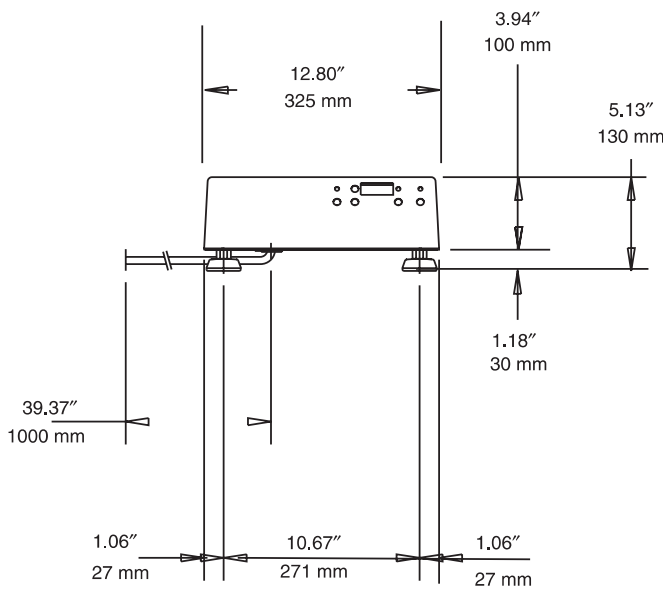

Side View

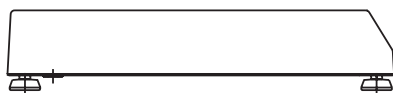

Libero Line Series
Infrared Cooktop

The company reserves the right to make modifications to the products without prior notice. All information correct at time of printing.

4-27-09