

User Instructions





Thank you for choosing our product. From now on, cooking will always be pleasantly creative with your new cooker.

We recommend carefully reading all the instructions in this manual, which includes detailed information about the most suitable conditions for using the cooker correctly and safely. These instructions also help you to become familiar with each component.

Useful advice is given for using recipients, utensils, positions of guides and control settings.

The correct cleaning operations contained in this manual allow you to maintain the cooker's performance unchanged over time.

The individual sections are set out in order to allow you to become familiar with all the functions in the cooker. The text is easy to comprehend and is accompanied with detailed images and simple pictograms.

Reading this manual thoroughly will provide you with the answer to any question that may arise regarding the correct use of your new cooker.



INSTRUCTIONS FOR THE INSTALLER: *for the **qualified technician** who is in charge of adequately checking the gas system, installing, commissioning and testing the appliance.*



INSTRUCTIONS FOR THE USER: *include suggestions, the description of the controls and the correct cleaning and maintenance operations for the appliance.*

1. General information	5
1.1 Technical service	5
2. Warnings for safety and use	6
3. Installation	8
3.1 General warnings	8
3.2 Fitting the adjustable feet	8
3.3 Electric connection	9
3.4 Power consumption of the vitroceramic hob	11
3.5 Ventilation requirements	12
3.6 Gas connection	12
3.7 Stability chain	13
3.8 Gas regulations	14
3.9 Connecting to LPG	14
4. Final operations	15
4.1 Levelling the cooker to the floor	15
5. Description of controls	16
5.1 The front panel	16
6. Using the cooking hob	22
6.1 Switching on the burners	22
6.2 Switching off the burners	22
7. Using the fry-top / steak grill	23
7.1 Before switching on the fry-top / steak grill	23
7.2 Switching on	23
7.3 Energy regulator table	23
7.4 Switching off	23
8. Using the vitroceramic hob	24
8.1 General warnings	24
8.2 Switching on	24
8.3 Switching off	24
9. Using the ovens	25
9.1 General warnings	25
9.2 Drawer and storage compartment	25
9.3 Using the electric multifunction oven	25
9.4 Using the auxiliary oven with natural convection	27

10. Cooking suggestions	28
10.1 Suggestions for using the hob burners correctly	28
10.2 Suggestions for using the fry-top / steak grill correctly	28
10.3 Suggestions for using the vitroceramic hob correctly	28
10.4 Suggestions for using the oven correctly	28
11. Cleaning and maintenance	31
11.1 Cleaning stainless steel surfaces	31
11.2 Cleaning enamelled surfaces	31
11.3 Cleaning the knobs and the control panel	31
11.4 Cleaning the grids and burners	31
11.5 Cleaning the igniter plugs and thermocouples	32
11.6 Cleaning the fry-top / steak grill	32
11.7 Cleaning the vitroceramic hob	32
11.8 Cleaning the oven	33
11.9 Replacing the oven light bulb	33
12. Special maintenance	34
12.1 Removing the oven door	34
12.2 Removing the side rack-holder frames	35
12.3 Removing and cleaning the inside oven fan	35

This user's manual is an integral part of the product purchased. The user must conserve the manual correctly so that it is always available for consultation during the use and maintenance of the product. Keep this user's manual for future reference. If the product is resold, the manual must be transferred to any subsequent owner or user of the product.

CLASSES OF APPLIANCES

The cooking appliances described in this operating manual belong to the following installation classes:

- **Class 1: non-flush-mounted** cooking appliance;

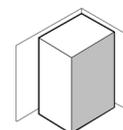

- **Class 2 – subclass 1:** cooking appliance **flush-mounted between two units**, made up of a single unit, but which can also be installed so that the side walls are accessible.

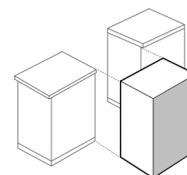

1. General information

This product conforms to the requirements of the following European directives:

- **73/23/EEC** for "Low Voltage".
- **89/336/EEC** for "Electromagnetic Disturbance".
- **90/396/EEC** for "Gas Appliances".
- **89/109/EEC** for "Material in contact with Food".

The above mentioned directives also conform to **Machine directive 98/37/EC**.

1.1 Technical service



Before leaving the factory, this appliance has been tested and set up by qualified, specialist personnel, so as to guarantee the best operating results. Each repair or adjustment that may subsequently be necessary must be carried out with the utmost care and attention. We therefore recommend always contacting the Dealer where the appliance was purchased or your nearest Service Centre, specifying the type of problem and the appliance model.

2. Warnings for safety and use

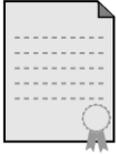

THIS MANUAL IS AN INTEGRAL PART OF THE APPLIANCE. IT SHOULD BE KEPT IN GOOD CONDITION AND CLOSE TO THE APPLIANCE FOR THE WHOLE LIFECYCLE OF THE COOKER. WE RECOMMEND READING THIS MANUAL VERY CAREFULLY BEFORE USING THE COOKER. IN CASE AN ADDITIONAL JETS KIT IS GIVEN AS ACCESSORY TO THE COOKER, WE RECOMMEND KEEPING AND PRESERVING IT. **THE INSTALLATION MUST BE CARRIED OUT BY QUALIFIED PERSONNEL AND IN COMPLIANCE WITH CURRENT STANDARDS.** THIS APPLIANCE IS FOR DOMESTIC USE AND CONFORMS TO THE **EEC DIRECTIVES** CURRENTLY IN FORCE. THE APPLIANCE IS BUILT FOR CARRYING OUT THE FOLLOWING FUNCTION: **COOKING AND HEATING FOOD**; ANY OTHER USE IS TO BE CONSIDERED IMPROPER. **THE MANUFACTURER DECLINES ANY RESPONSIBILITY SHOULD THE APPLIANCE BE USED FOR PURPOSES OTHER THAN THOSE INDICATED.**

AT THE MOMENT OF PURCHASE, THE USER ASSUMES DIRECT RESPONSIBILITY FOR THE PRODUCT AND MUST THEREFORE MAKE SURE THAT, WITH NORMAL USE, NO INSTABILITY, DEFORMATION, BREAKAGE OR WEAR OCCURS OVER TIME THAT WOULD REDUCE PRODUCT SAFETY.

THIS PRODUCT IS DESIGNED AND MANUFACTURED TO OPERATE SAFELY AND DOES NOT POSE ANY DANGERS TO PEOPLE, ANIMALS, AND OBJECTS.

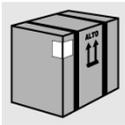

DO NOT LEAVE ANY PIECES OF THE PACKING UNATTENDED IN THE HOME. SEPARATE THE VARIOUS PACKING MATERIALS AND DELIVER THEM TO THE NEAREST RECYCLING CENTRE.

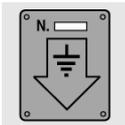

THE EARTH CONNECTION IS OBLIGATORY CONFORMING TO THE MODALITIES ENVISAGED BY THE SAFETY STANDARDS OF THE ELECTRICAL WIRING SYSTEM.

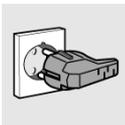

THE PLUG TO BE CONNECTED TO THE POWER SUPPLY CABLE AND THE RELATIVE SOCKET MUST BE THE SAME TYPE AND MUST COMPLY WITH CURRENT STANDARDS. AFTER INSTALLING THE APPLIANCE MAKE SURE THAT THE PLUG IS ACCESSIBLE TO ALLOW THE PERIODICAL CHECK-UP. **DO NOT PULL OUT THE PLUG BY PULLING THE CABLE.**



SHOULD THE GAS TAPS BE DIFFICULT TO ROTATE, LUBRICATE THEM USING A SPECIFIC PRODUCT FOR HIGH TEMPERATURES. **CONTACT THE TECHNICAL SERVICE FOR THIS OPERATION.**



IMMEDIATELY AFTER INSTALLATION, TEST THE APPLIANCE BRIEFLY BY FOLLOWING THE INSTRUCTIONS SHOWN BELOW. IN THE EVENT OF A MALFUNCTION, DISCONNECT THE APPLIANCE FROM THE MAINS AND CONTACT YOUR NEAREST TECHNICAL SERVICE CENTRE. **DO NOT ATTEMPT TO REPAIR THE APPLIANCE.**



EACH TIME YOU FINISH USING THE COOKING HOB, ALWAYS CHECK THAT THE CONTROL KNOBS ARE IN "ZERO" POSITION (OFF).



NEVER PUT INFLAMMABLE OBJECTS INTO THE OVEN: SHOULD IT BE ACCIDENTALLY SWITCHED ON, A FIRE MAY BREAK OUT. **IN THE EVENT OF A FIRE: CLOSE THE MAIN GAS SUPPLY AND CUT OFF THE ELECTRIC CURRENT.** DO NOT THROW WATER ON BURNING OR FRYING OIL. DO NOT STORE INFLAMMABLE OBJECTS OR AEROSOL CANS NEAR THE APPLIANCE AND DO NOT SPRAY NEAR THE BURNERS WHEN SWITCHED ON. DO NOT WEAR BAGGY CLOTHES OR ACCESSORIES THAT ARE NOT CLOSE TO THE BODY WHEN THE BURNERS ARE SWITCHED ON: SERIOUS INJURIES CAN BE CAUSED BY BURNING FABRIC.

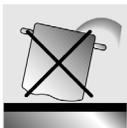

DO NOT REST SAUCEPANS THAT DO NOT HAVE A PERFECTLY SMOOTH, EVEN BASE ON THE COOKING HOB.

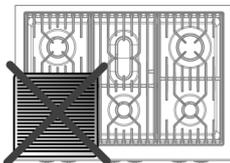

DO NOT USE RECIPIENTS OR STEAK GRILLS THAT EXCEED THE OUTER PERIMETER OF THE COOKING HOB.

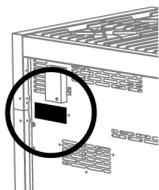

THE IDENTIFICATION PLATE WITH THE TECHNICAL DATA, SERIAL NUMBER AND THE MARK IS CLEARLY VISIBLE ON THE BACK OF THE APPLIANCE.
THE PLATE MUST NEVER BE REMOVED.



THE APPLIANCE SHOULD ONLY BE USED BY ADULTS. DO NOT ALLOW CHILDREN TO APPROACH OR PLAY WITH THE APPLIANCE. NEVER STORE ITEMS THAT CHILDREN MAY ATTEMPT TO REACH ABOVE THE APPLIANCE. THE HEATING UP OF SOME PARTS OF THE APPLIANCE AND OF THE USED PANS MAY BE A DANGER, SO DURING FUNCTIONING AND DURING ALL THE TIME NECESSARY FOR THE COOLING DOWN, TAKE CARE TO POSITION THE HOT PANS IN A WAY TO PREVENT BURNS OR OVERTURNING. AVOID LEAVING THE OVEN DOOR OPEN DURING FUNCTIONING OR IMMEDIATELY SOON AFTER THE SWITCHING OFF. AVOID TOUCHING THE HEATING ELEMENTS INSIDE THE OVEN AND GRILLS AS WELL.



RESTING OR SITTING ON THE OPEN OVEN DOOR, DRAWERS OR STORAGE COMPARTMENT CAN OVERTURN THE APPLIANCE, AND CONSEQUENTLY CAUSE HARM. THE DRAWERS HAVE A DYNAMIC CAPACITY OF 25 KG.

IF THE COOKER IS SET ON A PEDESTAL, APPROPRIATE MEASURES MUST BE TAKEN TO PREVENT IT FROM SLIDING OFF THE PEDESTAL.



WHEN THE APPLIANCE IS DECOMMISSIONED, IT MUST BE DISPOSED OF IN A SUITABLE RECYCLING CENTRE. CUT OFF THE MAINS POWER CORD AFTER UNPLUGGING IT FROM THE WALL OUTLET, AND MAKE SAFE ANY COMPONENTS WHICH MIGHT BE DANGEROUS FOR CHILDREN (DOORS, ETC.).



THIS APPLIANCE IS MARKED ACCORDING TO THE **EUROPEAN DIRECTIVE 2002/96/EC** ON WASTE ELECTRICAL AND ELECTRONIC EQUIPMENT (**WEEE**). BY ENSURING THIS PRODUCT IS DISPOSED OF CORRECTLY, YOU WILL HELP PREVENT POTENTIAL NEGATIVE CONSEQUENCES FOR THE ENVIRONMENT AND HUMAN HEALTH, WHICH COULD OTHERWISE BE CAUSED BY INAPPROPRIATE WASTE HANDLING OF THIS PRODUCT.

THE SYMBOL  ON THE PRODUCT, OR ON THE DOCUMENTS ACCOMPANYING THE PRODUCT, INDICATES THAT THIS APPLIANCE MAY NOT BE TREATED AS HOUSEHOLD WASTE. INSTEAD IT SHALL BE HANDED OVER TO THE APPLICABLE COLLECTION POINT FOR THE RECYCLING OF ELECTRICAL AND ELECTRONIC EQUIPMENT. DISPOSAL MUST BE CARRIED OUT IN ACCORDANCE WITH LOCAL ENVIRONMENTAL REGULATIONS FOR WASTE DISPOSAL. FOR MORE DETAILED INFORMATION ABOUT TREATMENT, RECOVERY AND RECYCLING OF THIS PRODUCT, PLEASE CONTACT YOUR LOCAL CITY OFFICE, YOUR HOUSEHOLD WASTE DISPOSAL SERVICE OR THE SHOP WHERE YOU PURCHASED THE PRODUCT.



The manufacturer declines any responsibility for damage incurred by persons or objects that is caused by not following the above guidelines or by tampering with any part of the appliance or by using non-original spare parts.



3. Installation

DIMENSIONS OF THE COOKERS

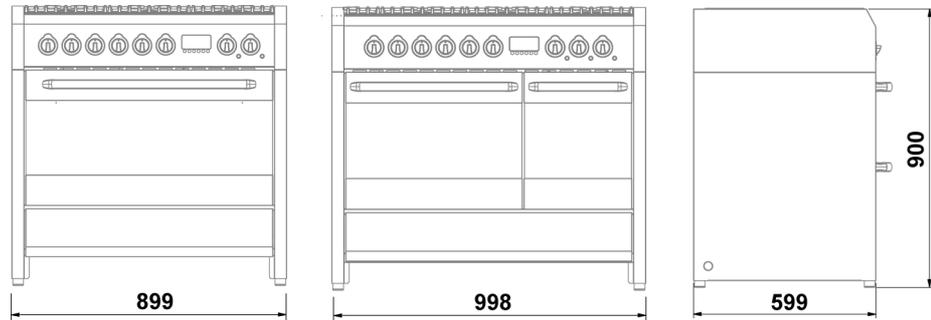

3.1 General warnings



It is the law that a competent person installs all gas appliances. In the UK Corgi gas installers are approved to work to safe and satisfactory standards. The cooker must be installed in accordance with BS 6172. Failure to install the cooker correctly could invalidate the warranty liability claims could and could lead to prosecution.

The manufacturer declines any responsibility for damage incurred by persons, animals or objects that is caused by not following the above guidelines (cfr. chapter “2. Warnings for safety and use”).

The technical data is indicated on the plate located on the back of the appliance. The adjustment conditions are shown on a label applied to the packing and the appliance.

Do not use the oven door handle for handling the appliance, or for removing the appliance from the packing.

3.2 Fitting the adjustable feet



Before turning the cooker over, we recommend removing all the parts that are not stably attached to it, in particular the cooking hob grids and burners. To lighten the weight of the cooker, the accessories inside the oven may also be removed, thereby preventing accidental damage during the overturning operation.

The cooker is delivered with the feet removed. Before moving and hooking up the cooker, take the feet from the packing and screw them onto the cooker. This can be done in one of two ways:

- A** Lifting the cooker off the floor.
- B** Laying the cooker on its back.

The **final regulation** of the feet to level the cooker to the floor will be done **after the gas and electric hook-ups have been made.**

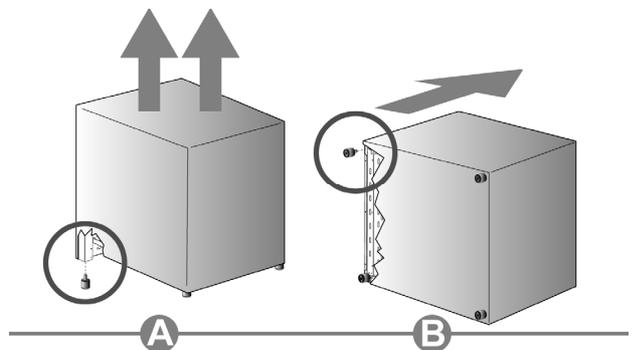

Should it be necessary to drag the cooker, screw the feet in completely and carry out the final regulation only when the other operations are completed.



3.3 Electric connection



Make sure that the voltage and the size of the mains corresponds to the specifications shown on the plate located on the back of the appliance.

The plate must never be removed.



The plug at the end of the power supply cable and the wall socket must be the same type and must comply with current electric standards. Check that the mains is adequately earthed. Once the appliance has been installed make sure that the plug is accessible to allow the periodical check-up. The power supply cable should conform to BS6004.



Prepare an omni-polar cutoff device on the power supply line of the appliance with a contact opening distance equal to or more than **3 mm**, located in a convenient position near the appliance.

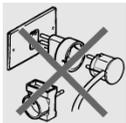

Do not use reducers, adapters or shunts.

Before making the electric connection, make sure of the efficiency of the earthing.

Make sure that the relief valve and the home wiring system are able to withstand the appliance load.

The yellow/green earth cable must not be subject to cutoffs.

The electric cable must not come into contact with parts whose temperature is more than **50°C** higher than room temperature.

The cooker should be installed in accordance with the latest edition of the IEE regulations.

3.3.1 Electric power cable section

According to the type of power supply, use a cable that conforms to the following table.

Running at 400V3N~ (models connected according to DIAGRAM "A"): use a pentapolar cable type H05RR-F/H05RN-F (cable measuring 5 x 2.5 mm²).

Running at 230V3~ (models connected according to DIAGRAM "C" but commutated by the installer according to DIAGRAM "B"): use a tetrapolar cable type H05RR-F/H05RN-F (cable measuring 4 x 4 mm²).

Running at 230V1N~ (models connected according to DIAGRAM "C"): **up to 2.9 kW** use a tripolar cable type H05RR-F/H05RN-F (cable measuring 3 x 1.5 mm²); **between 2.9 kW and 5.4 kW** use a tripolar cable type H05RR-F/H05RN-F (cable measuring 3 x 2.5 mm²); **between 5.4 kW and 7 kW** use a tripolar cable type H05RR-F/H05RN-F (cable measuring 3 x 4 mm²); **over 7 kW** use a tripolar cable type H05RR-F/H05RN-F (cable measuring 3 x 6 mm²).

The end to be connected to the appliance must have the earth wire (**yellow-green**) at least **20 mm** longer.

The cable type **H05RN-F** is to be used for the models with fryer, while cable type **H05RR-F** for those without fryer.

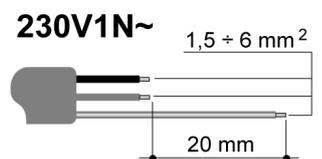
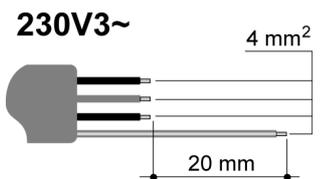
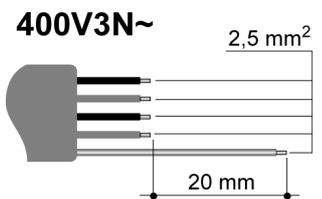



3.3.2 Type of power supply

It is possible to obtain different connections according to the voltage, simply by moving the unconnected cable ends on the terminal board as shown in the following diagrams. According to the model, consult the table "CONNECTION TO THE TERMINAL BOARD".

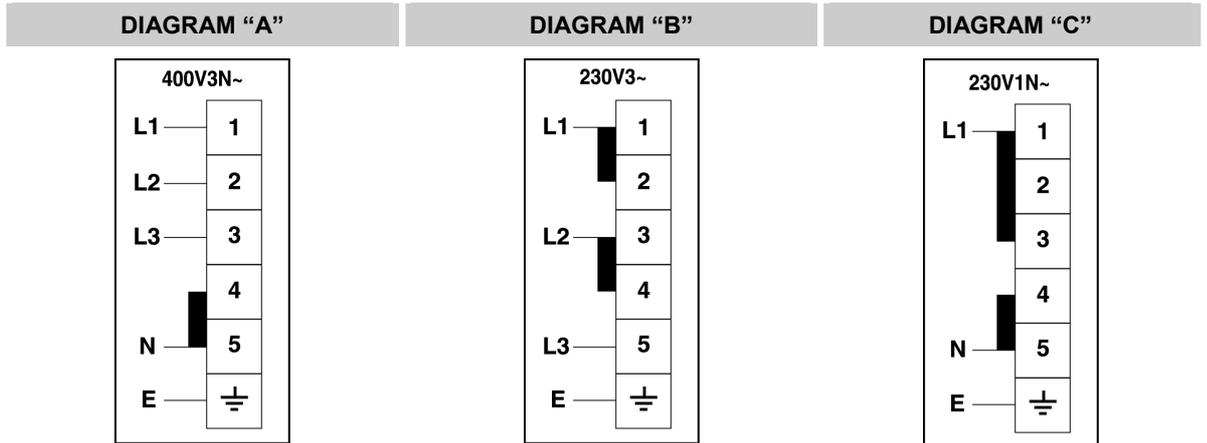

CONNECTION TO THE TERMINAL BOARD		
MODEL	POWER kW	POWER SUPPLY
COOKER 6 BURNERS (1 OVEN)	2,9	DIAGRAM "C"
COOKER VITROCERAMIC HOB (1 OVEN) (5 HEATING ELEMENTS)	12,7	DIAGRAM "A"
COOKER 6 BURNERS (2 OVENS)	3,9	DIAGRAM "C"
COOKER 4 BURNERS (2 OVENS) + T	6,3	
COOKER VITROCERAMIC HOB (2 OVENS) (5 HEATING ELEMENTS)	13,7	DIAGRAM "A"
T = FRY-TOP		
MODELS CONNECTED ACCORDING TO DIAGRAM "A" CAN BE COMMUTATED BY THE INSTALLER ACCORDING TO DIAGRAM "B".		
MODELS CONNECTED ACCORDING TO DIAGRAM "C" CAN BE COMMUTATED BY THE INSTALLER ACCORDING TO DIAGRAM "A".		



3.3.3 Replacing the electric cable

To replace the electric cable, it is necessary to access the terminal board. It is located on the back of the appliance, at the top left, as shown in the figure.

To replace the cable, proceed as follows:

- open the terminal board box;
- unscrew the screw **A** that locks the cable;
- loosen the screw contacts and replace the cable with one of the same length that corresponds to the specifications in the table in section "3.3.1 Electric power cable section";
- the "yellow-green" earth wire must be connected to the terminal \oplus and must be approximately **20 mm** longer than the line cables;
- the neutral "blue" wire must be connected to the terminal marked with the letter **N**;
- the line wire must be connected to the terminal marked with the letter **L**.

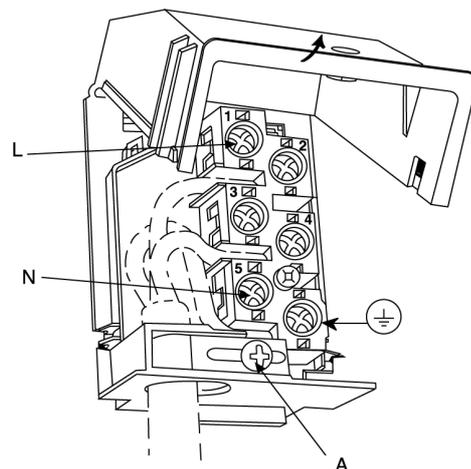

3.4 Power consumption of the vitroceramic hob

The vitroceramic hob has different power consumptions depending on the type of heating element used. The diagram shows the values of the power consumed.

In the envisaged cases, the first numeric value refers to the total power, whereas the value that follows the symbol "/" refers to the inside diameter, with the exception of the central heating element, whose value that follows "/" refers to the outer diameter.

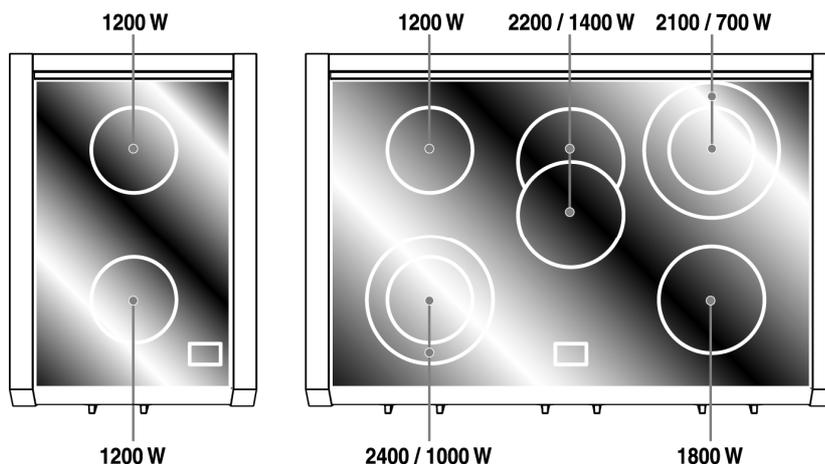



3.5 Ventilation requirements

The room containing the appliances should have an air supply in accordance with B.S. 5440 part 2.

1. All rooms require an opening window or equivalent, and some rooms will require a permanent vent as well.
2. For room volumes up to 5m³ an air vent of 100cm² is required.
3. If the room has a door that opens directly to the outside, and the room exceeds 1m³ no air vent is required.
4. For room volumes between 5m³ and 10m³ an air vent of 50cm² is required.
5. If there are other fuel burning appliances in the same room B.S. 5440 part 2 should be consulted to determine the air vent requirements.
6. The appliance must not be installed in a bed sitting room of less than 20m or in a bathroom or shower room.

Windows and permanent vents should therefore not be blocked or removed without first consulting a Corgi gas installer.

Failure to install appliances correctly is dangerous and could lead to prosecution.

DO NOT install LPG version below ground level. This does not exclude installation into a room, which equates to a basement on one side of the building, but open to ground level on the opposite side.

3.6 Gas connection



Gas-powered devices for home use, which are not connected to a conduit for the evacuation of combustion products, must not cause a concentration of carbon monoxide that could pose a health risk to the persons exposed in relation to the time of exposure.

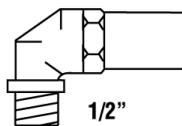

We recommend checking that the appliance is properly set up for the type of gas distributed. The threaded 1/2" gas connection pipe is located at the rear on the right hand side of the appliance.

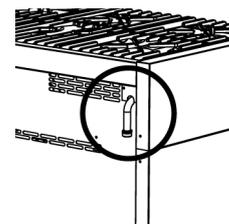

The cooker is designed to match the depth of standard 600mm worktops. An adaptor back plate should, therefore, be fitted within the shaded area shown to allow the cooker to be pushed in fully and chased to the wall.

Connection to the cooker should be made with an approved appliance flexible connection to BS 669. A length of 0.9 to 1.25m is recommended. The length of hose chosen should be such that when the cooker is in situ, the hose does not touch the floor.

The temperature rise of areas at the rear of the cooker that are likely to come in contact with the flexible hose do not exceed 70°C.

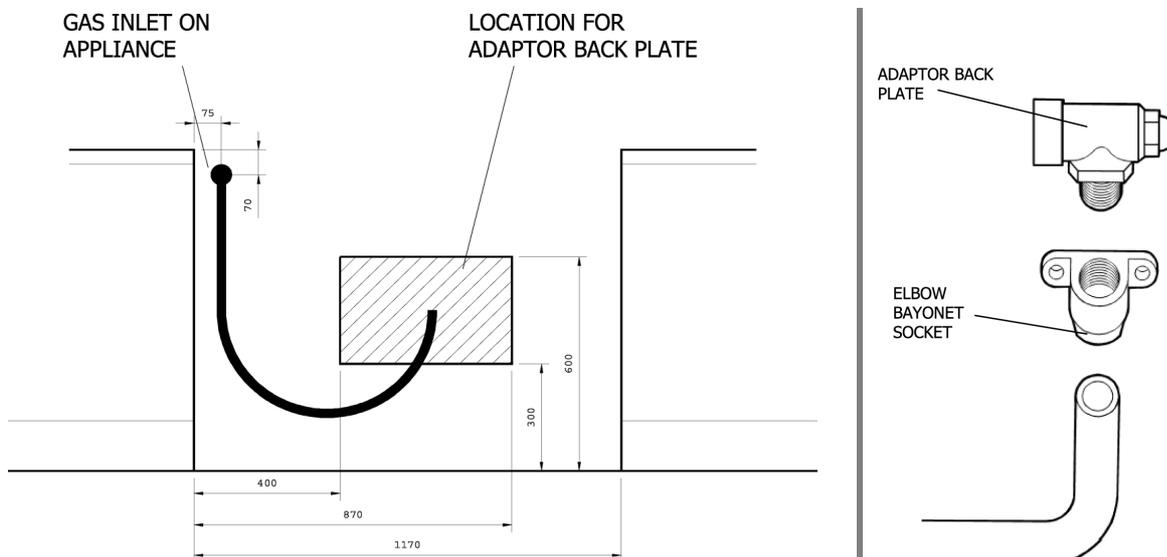



3.7 Stability chain

The cooker is fitted with a stability device such as a proprietary stability chain as shown and firmly secured to the fabric of the building.

Whatever the position, remember to leave enough room for the cooker to be pulled out for cleaning and service.

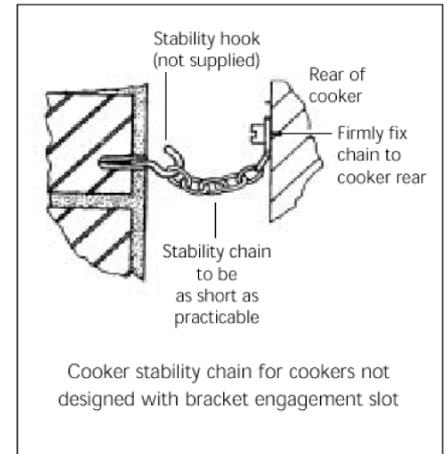

The wall behind the cooker between the hotplate and 450mm above, and across the width of the cooker, must be an incombustible material such as ceramic wall tiles.

This appliance is designed not to project in front of standard 600mm worktops (excluding handles). To achieve the best fit the cooker must be pushed against the wall.

As this appliance is very heavy it should be situated on a suitably hard surface as to ensure servicing and installation is made possible with minimal impact on the floor surface.

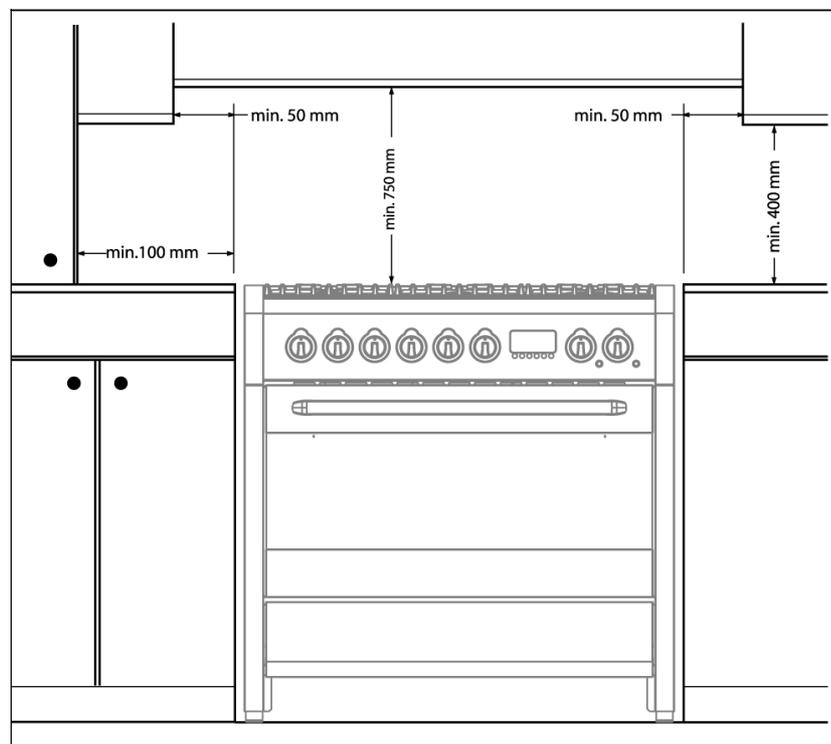



3.8 Gas regulations

If the cooking appliance is set up for a **different** type of gas than that available, its injectors must be replaced, the minimum flow regulated. In order to replace the injectors in the cooking hob, it is necessary to carry out the following operations:

- remove the pan supports;
- remove the burners and burner caps (**Fig. A**);
- take out the injector (**Fig. B**) and replace it with one suitable for the new type of gas (see "**GENERAL INJECTORS TABLE**");
- replace the gas label (on the rear of the appliance) with the new one provided with the injectors kit;
- refit all parts by following the disassembly instructions in reverse order and taking care to position the burner cap correctly on the burner.

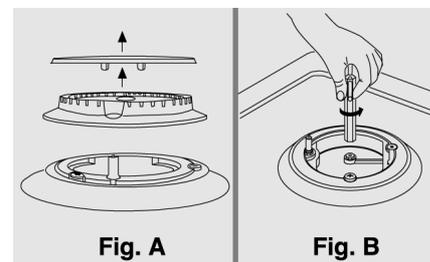

3.8.1 Minimum flow of valved cooking hob taps

- Switch on the burner and turn the control knob towards the minimum flow position ;
- remove the knob;
- using a screwdriver, adjust the internal screw **Z** until the correct low flame is obtained;
- refit the knob.

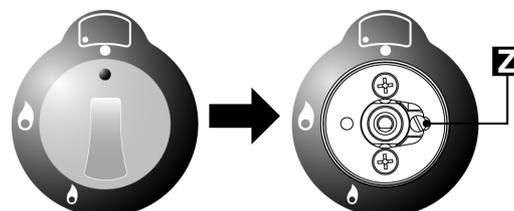

3.8.2 Minimum flow of non-valved cooking hob taps

- Switch on the burner and turn the control knob towards the minimum flow position ;
- remove the knob;
- insert a small screwdriver into the rod of the tap and adjust the internal screw **Z** until the correct low flame is obtained;
- refit the knob.

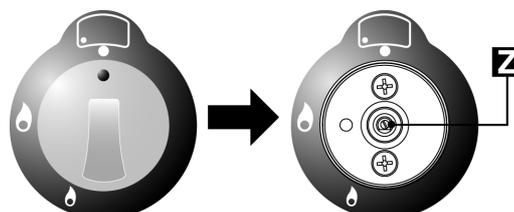

- *Unscrew the adjustment screw **Z** to increase the flow, or tighten it to reduce the flow.*
- *The adjustment is correct when the low flame measures approximately 3 or 4 mm.*
- *When changing quickly from maximum to minimum flow and vice versa **make sure that the flame does not go out.***

GENERAL INJECTORS TABLE

TYPE OF GAS	mBar	NOZZLE NO.	BURNERS POSITION TYPE	POWER Watt		CONSUMPTION
				MAX.	MIN.	MAX.
NATURAL GAS	20	115	RAPID	3000	750	286 l/h
		97	SEMI RAPID	1750	480	167 l/h
		72	AUXILIARY	1000	330	95 l/h
		128	TRIPLE-RING	3300	1300	314 l/h
		94	FISH KETTLE	1900	750	181 l/h
LPG BUTANE PROPANE	30 28 37	85	RAPID	3000	750	219 g/h
		65	SEMI RAPID	1750	480	128 g/h
		50	AUXILIARY	1000	330	73 g/h
		93	TRIPLE-RING	3300	1300	241 g/h
		68	FISH KETTLE	1900	750	138 g/h

3.9 Connecting to LPG

Use a pressure regulator and connect to the cylinder in compliance with the guidelines set out in standards regulations in force.





4. Final operations

4.1 Levelling the cooker to the floor

After having made the electrical and gas hook-ups, level the cooker to the floor using the adjustable feet that were previously screwed onto the bottom of the cooker.

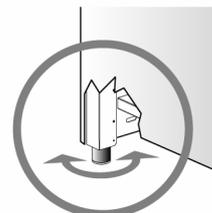

*Should it be necessary to drag the cooker, **screw the feet in completely and carry out the final regulation only when the other operations are completed.***



5. Description of controls

5.1 The front panel

All the commands and controls for the cooking hob and oven are on the front panel.

THE CONTROL PANEL

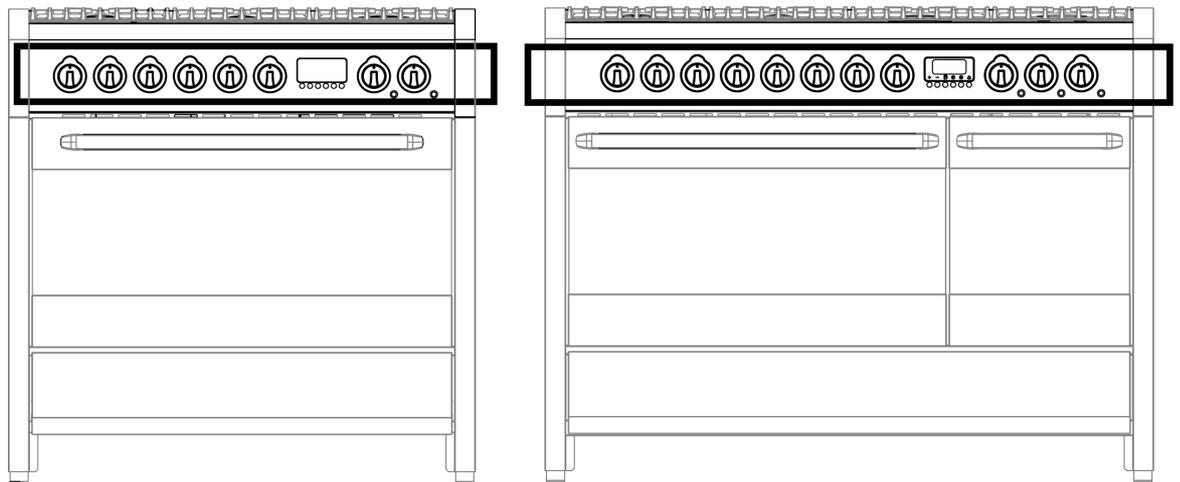

DESCRIPTION OF HOB BURNER KNOB

The flame is lit by simultaneously pressing and turning the knob anticlockwise to the low flame symbol .

To regulate the flow of the flame, turn the knob to between the maximum  and minimum  settings. Turn off the burner by returning the knob to position .



LAYOUT OF BURNERS – Description of symbols

	REAR LEFT		REAR RIGHT
	REAR CENTRE LEFT		REAR CENTRE RIGHT
	CENTRE FRONT		CENTRE REAR
	FRONT CENTRE LEFT		FRONT CENTRE RIGHT
	FRONT LEFT		FRONT RIGHT



DESCRIPTION OF FRY-TOP / STEAK GRILL AND GRILL KNOB

FRY-TOP/STEAK GRILL: is equipped with **differentiated heating**. The entire cooking surface can be used, or only one of the two halves, front or rear. The knobs that regulate the energy individually control the temperature of the two heating elements. A **red light** indicates that the appliance is heating.

GRILL: two warning lights give essential information on how the appliance is working. The **orange light** switches on to indicate that the appliance is powered (ON). A **red light** indicates that the heating element is heating up.



LAYOUT OF HEATING ELEMENTS - Description of symbols



REAR



FRONT

DESCRIPTION OF VITROCERAMIC HOB KNOBS

Besides the normal knobs that regulate the energy, the vitroceramic hob is equipped with knobs for **differentiated heating**. Settings from **1** to **11** control the heating of the internal element, setting the knob to the symbol ● the outer element also operates.



LAYOUT OF HEATING ELEMENTS - Description of symbols



REAR LEFT



REAR RIGHT



FRONT LEFT



FRONT RIGHT



CENTRAL

DESCRIPTION OF ELECTRIC OVEN KNOBS

The electric oven is controlled by two knobs: **function switch knob** and **thermostat knob**. They allow you to choose the most suitable type of heating for different cooking requirements, by switching on the heating elements appropriately and setting the required temperature (from **50°C** to **MAX**).

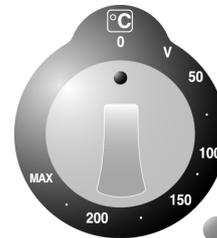

The **V** setting on the thermostat knob operates the oven fan.

Below the oven knobs there are two warning lights: the **red light** signals the oven is working; the **orange light** indicates that the preset temperature has been reached. The **orange light** switches on and off to indicate when the heating automatically kicks in to maintain the temperature inside the oven at the level set on the thermostat knob.

The oven has an **internal light**. The light is always on while the oven is working: it can be switched on while the oven is off, for cleaning purposes, by turning the function switch knob to the symbol ☼



DESCRIPTION OF SYMBOLS ON THE FUNCTION SWITCH KNOB

	SWITCH ON LIGHT INSIDE OVEN		GRILL-FAN ELEMENT
	UPPER AND LOWER HEATING ELEMENTS		UPPER AND LOWER HEATING ELEMENTS – FAN
	UPPER HEATING ELEMENT		HEATING ELEMENT-CONVECTION
	LOWER HEATING ELEMENT		DEFROST
	GRILL ELEMENT		

DESCRIPTION OF AUXILIARY ELECTRIC OVEN KNOB

Some cooker models are equipped with an auxiliary electric oven with natural convection, controlled by a single knob. This allows the user to choose the most suitable type of heating for different cooking requirements, by switching on the heating elements appropriately and setting the required temperature (from **60** to **MAX**). Using the same knob it is also possible to set the functions described in the table.

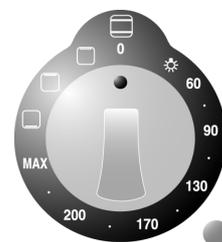

Below the auxiliary oven knob there is an **orange light**, which indicates when the oven has reached the set temperature. The **orange light** switches on and off to indicate when the heating automatically kicks in to maintain the temperature inside the auxiliary oven at the level set on the control knob.

The auxiliary oven has an **internal light**. The light is always on while the oven is working: it can be switched on while the oven is off, for cleaning purposes, by turning the function switch knob to the symbol .

DESCRIPTION OF SYMBOLS ON AUXILIARY ELECTRIC OVEN KNOB

	SWITCH ON LIGHT INSIDE OVEN		UPPER HEATING ELEMENT
60÷MAX	UPPER AND LOWER HEATING ELEMENTS		GRILL ELEMENT + SPIT
	LOWER HEATING ELEMENT		



THE ELECTRONIC TIMER

KEY

A	COOK TIME
B	END TIME
C	COUNTDOWN
D	TIME
E	DECREASE CONTROL
F	SELECTOR CONTROL
G	INCREASE CONTROL

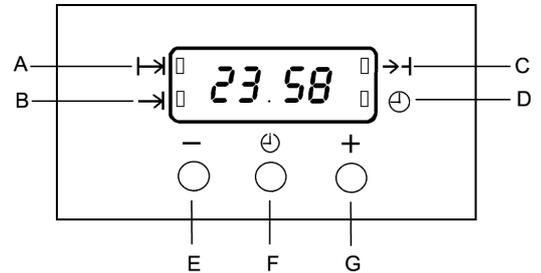

The time of day must be set before the main oven will operate manually.

SET THE TIME OF DAY

The oven has a 24 hour clock.

When the electricity supply is first switched ON, the display will show 12.00 and the 'Time' (⊖) indicator neon will flash as Fig. 1.

To set the correct time press the increase control button (+) and if necessary, the decrease control button (-) until the correct time on the 24 hour clock is reached, e.g. 10.00 a.m. as Fig. 2. The 'Time' indicator (⊖) neon will flash for 5 seconds and then go out.

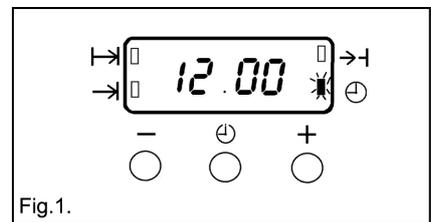

Fig.1.

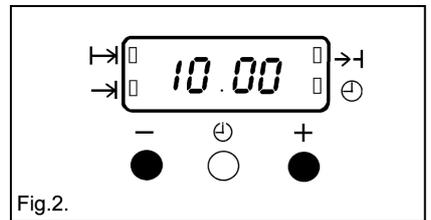

Fig.2.



The increase and decrease control buttons operate slowly at first, and then more rapidly. They should be pressed separately.

HOW TO SET THE COUNTDOWN

The 'Countdown' gives an audible reminder at the end of any period of cooking. This cooking period may be up to 2 hrs 30 mins. It is not part of the automatic control.

To set, press the Selector Control button (⊖) until the 'Countdown' indicator is illuminated (→) the display reads 0.00 as Fig. 3.

To set the correct time duration depress the increase control (+) until the display indicates the interval to be timed, e.g. 1hr 45 mins as Fig. 4. If necessary depress the decrease control (-) to achieve the correct time interval.

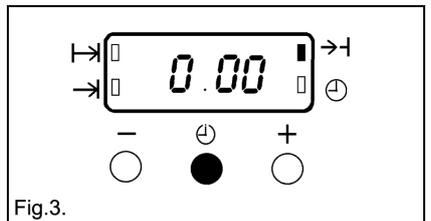

Fig.3.



This must be completed within 5 seconds of first pressing the Selector Control button.

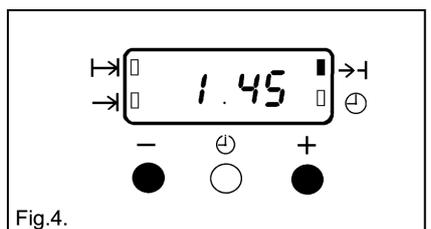

Fig.4.

During the operation of the 'Countdown', the remaining time period will be shown in the display. The 'Countdown' will sound intermittently for up to 2 minutes at the end of the timed period. The sound can be stopped by pressing any button.



TO CANCEL THE COUNTDOWN

If you change your mind and want to cancel the 'Countdown', press the Selector Control button until the 'Countdown' indicator (→|) flashes and then the decrease control (-) until 0.00 shows in the display as Fig. 5. The 'Countdown' indicator (→|) will continue to flash for a few seconds and then return to the time of day.

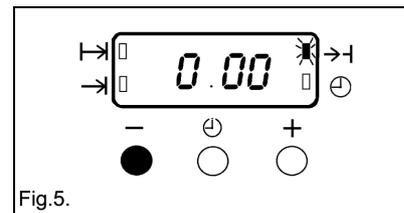

Fig.5.

SETTING THE OVEN TIMER CONTROL

The main oven can be automatically timed.

When using the timer control for the very first time, it is advisable to let it operate while you are at home. The displays can be checked to show that it is operating correctly and you will feel confident to leave a meal to cook automatically in the future.

A) TO SET THE TIMER TO SWITCH ON AND OFF AUTOMATICALLY

- i) Ensure the electricity supply is switched ON and that the correct time of day is displayed, e.g. 9 a.m. as Fig. 6.
- ii) Place food in oven.
- iii) To set the length of cooking time, press the Selector control button (⊖) until the 'Cook Time' indicator is illuminated (|→). Press the increase control (+) until the required length of cooking time is displayed, e.g. 2 hrs 15 mins as Fig. 7. If necessary depress the decrease control (-) until the correct time interval is achieved.

The maximum cooking time is 10 hours.

- iv) Release the buttons. The 'Cook Time' indicator (|→) will be illuminated.

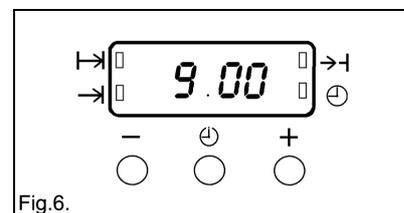

Fig.6.

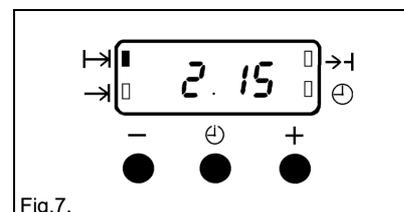

Fig.7.

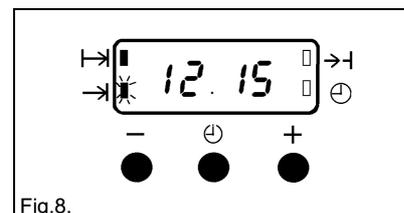

Fig.8.



Remember, this must be completed within 5 seconds of first pressing the Selector Control button.

- v) To set the 'End Time'. Press the Selector Control button until the 'End Time' (→|) flashes. Press the increase control (+) until the required stop time is displayed, e.g. 12.15 p.m. as Fig. 8. If necessary depress the decrease control (-) until the correct time interval is achieved.
- vi) Release the buttons. The time of day will be displayed after 5 seconds. The 'Cook Time' (|→) and 'End Time' (→|) indicators will be illuminated.
The 'End Time' must not be more than 23 hours 59 minutes from the time of day. For example, if the time of day is 09.00 a.m., the latest 'End Time' would be 08.59 a.m. the next day.
- vii) Set the main oven control to the required temperature. The oven indicator neon should be OFF.



When the automatic timed period starts, the oven indicator neon will turn ON and OFF periodically during cooking, showing that the temperature is being maintained.



B) TO SET THE TIMER TO SWITCH OFF ONLY

- i) Ensure the electricity supply is switched ON and that the correct time of day is displayed, e.g. 10.00 a.m. as Fig. 9.
- ii) Place food in oven.
- iii) To set the length of cooking time, press the Selector Control button until the 'Cook Time' (I→) indicator is illuminated. Press the increase control (+) until the required length of cooking time is displayed, e.g. 2 hrs 15 mins as Fig. 10. Depress the decrease control (-) if necessary.
- iv) Release the buttons. The 'Cook Time' indicator (I→) will illuminate and the time of day will be displayed after 5 seconds.
- v) Set the oven temperature. The oven indicator neon should be ON.
- vi) To check the 'End Time' during the cooking period, simply press the Selector Control button once and the remaining time will be displayed, as Fig. 11.

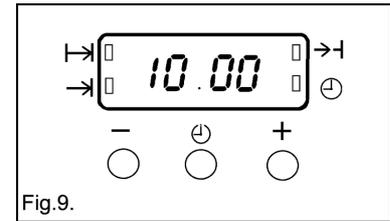

Fig.9.

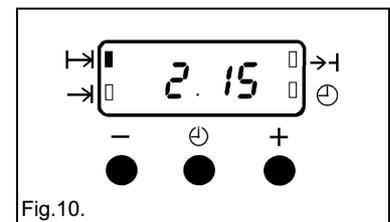

Fig.10.

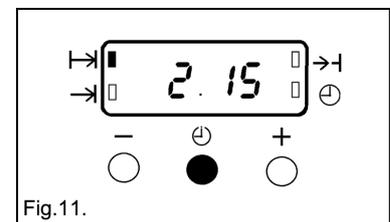

Fig.11.

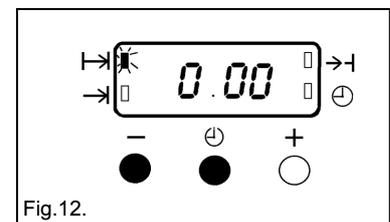

Fig.12.

TO CANCEL AN AUTOMATIC PROGRAMME

- i) To cancel an automatic programme press the Selector Control button until the 'Cook Time' indicator (I→) neon flashes. Press the decrease control (-) until the display reads 0.00 as Fig. 12.
- ii) Release the buttons. The 'Cook Time' indicator (I→) will flash and after 5 seconds return to the time of day.
- iii) Turn off oven control.

TO RETURN THE APPLIANCE TO MANUAL

At the end of a timed cooking period, the indicator neon will flash and an alarm will sound for up to 2 minutes.

- i) To stop the sound press any of the three buttons, as Fig. 13.
- ii) The display will return to the time of day.
- iii) Turn off the oven controls.

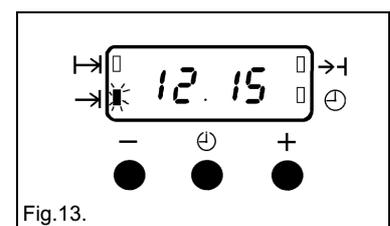

Fig.13.

THINGS TO NOTE

In the event of an interruption of the electricity supply, the timer will reset itself to zero, and all programming will be cancelled.

AUTOMATIC COOKING

It is advisable to leave food in the oven for as short a time as possible before automatic cooking. Always ensure commercially prepared food is well within its use by date and that home prepared food is fresh and of good quality.

When cooking is complete, **do not** leave food to stand in the oven, but remove and cool it quickly if the food is not to be consumed immediately.

Always ensure food in the oven has been covered before cooking if it is not possible to remove food immediately after cooking.



6. Using the cooking hob



Make sure that the flame caps, the burner caps and the pan supports are fitted correctly.



During normal operations, the appliance heats up considerably. Caution should therefore be used. **Do not allow children to approach the appliance. Do not leave the cooking hob unattended while it is on.**

6.1 Switching on the burners



All the hob burner knobs have the following symbols:

- tap closed
- 🔥 high flame
- 🔥 low flame

The low flame setting is found by turning the knob anticlockwise all the way. All intermediate settings must be selected between the high flame and low flame, **never between high flame and closed.**

6.1.1 One-touch lighting

The hob burners are equipped with a "one-touch" lighting system. To switch on one of the burners, press the knob corresponding to the required burner and turn it anticlockwise to the low setting 🔥. Hold down the knob to activate the automatic "one-touch" lighting system. When the burner is on, hold down the knob for approximately **10 seconds**, to allow the safety valve to open. In the event of a power cut, the burner can also be lit with a match (see section "6.1.2 Manual lighting").



Should the burner switch off accidentally, the safety thermocouple blocks the gas flow, even when the tap is open.



Appliances not equipped with safety valve: it is not necessary to hold down the knob (the burner is immediately operative). Take care, however, as **if the flame should go out accidentally**, gas will continue to come out of the burner.

The device should not be activated for longer than **15 seconds**. If after that time it fails to operate stop pressing the knob, open the window and **wait 1 minute** before trying again. In case the flame goes out accidentally turn off the knob and do not try to switch on the burner for at least **1 minute**.

6.1.2 Manual lighting

To light one of the burners, move a lit match towards the burner, press the corresponding knob and turn it anticlockwise to the minimum setting 🔥. Release the knob.

6.2 Switching off the burners

At the end of the cooking, return the knob to position ●.



7. Using the fry-top / steak grill



During normal operations, the appliance heats up considerably. Caution should therefore be used. **Do not allow children to approach the appliance. Do not leave the fry-top/steak grill unattended while it is on.**

Depending on the model, the appliance is fitted with a **fry-top** with smooth griddle, or a **steak grill** with lined griddle.

FRY-TOP

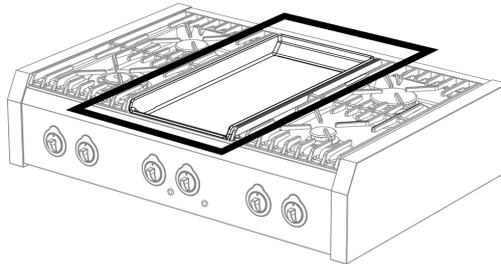

STEAK GRILL

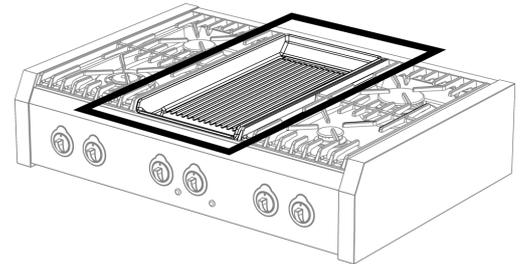

7.1 Before switching on the fry-top / steak grill

The first time it is used, the fry-top/steak grill griddle may develop an acrid or burnt smell caused by oily residue from manufacturing that may give unpleasant odours or flavours to food. To eliminate this problem, clean the griddle as described in section “11.6 Cleaning the fry-top / steak grill” before use.

7.2 Switching on

The fry-top/steak grill is equipped with **differentiated heating**. The entire surface of the griddle can be used, or only one of the two halves, front or rear.

Position the control knob of the heating element to the required setting. The **red light** switches on to indicate the appliance is working. Place the food on the griddle and cook as preferred.

7.3 Energy regulator table

The following table offers only indicative values because, according to the thickness and type of food, as well as personal taste, the heat should be higher or lower.



1 - 4	Maintaining the heat on the griddle
5 - 7	For light cooking
8 - 9	To grill
10 - 11	To grill thicker meat
11	For rapid warming and cleaning

7.4 Switching off

After cooking, return the knob to position ●.



8. Using the vitroceramic hob



During normal operations, the appliance heats up considerably. Caution should therefore be used. **Do not allow children to approach the appliance.** Do not leave the vitroceramic hob unattended while it is on.

8.1 General warnings

The first time it is heated, the vitroceramic hob may develop an acrid or burnt smell caused by oily residue from manufacturing, which disappears completely after repeated use.

The vitroceramic hob is fitted with a cooking area with various diameters and power (see section "3.4 Power consumption of the vitroceramic hob"). Their position is clearly indicated with circles and the heat is delimited within the diameters marked on the glass.

8.2 Switching on



Position the pan or pot with the food to be cooked inside it on the required heating element. Turn the energy regulator knob to the required setting. After a few moments, the **latent heat light** corresponding to the selected heating element switches on.

If the vitroceramic hob is used to boil water, once it has boiled, turn the energy regulator knob to a lower setting to prevent the liquid in the pot from boiling over and soiling the surface.



Some knobs are fitted with a **supplementary heating setting (griddle with dual heating element)**. To activate it, turn the energy regulator knob to position 11.

8.3 Switching off

After cooking, return the knob to position 0.

The vitroceramic hob features a **latent heat light** which reproduces in reduced scale the position of the heating diameters. This light signals that the surface area is still hot.

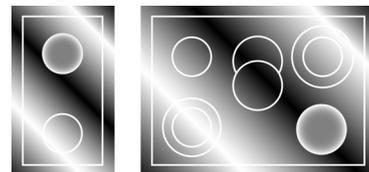

Do not clean or touch the surface until the latent heat light has switched off.



9. Using the ovens

9.1 General warnings



When the oven or grill is operating, the outer walls and oven door can become very hot. **Keep children away from the appliance. Do not allow children to sit on the oven door or play with it. Do not use the door as a stool.**

Do not cook food on the bottom of the oven.

When using the oven for the first time, or after a power cut, the display flashes regularly indicating 0:00. To set the display, refer to section "SET THE TIME OF DAY" on page 19.

Do not attempt to disassemble the oven door without consulting the relative instructions carefully (refer to section "12.1 Removing the oven door"): **the hinges on the oven door may injure the hands.**



HEATING BLOCK OF THE OVEN

If during normal operation the oven interrupts heating and the programmer display begins to flash and goes to zero, check whether:

- there has been a current interruption.

If the block occurs again after the cooking programme has been restarted, this means that the safety device has been tripped. This device intervenes in the event of a thermostat fault and prevents oven overheating. In such case, we recommend that you not try to light the oven again and that you contact your nearest service centre.

9.2 Drawer and storage compartment

In some models a storage drawer is provided on the lower part of the cooker beneath the oven or in the next side compartment. Use this cabinets only to store metal cooker accessories.

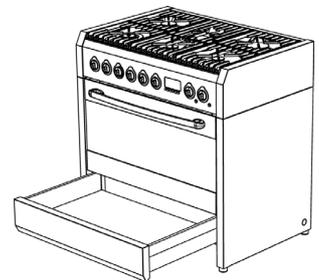

Do not store inflammable material such as cloths, paper or similar in the drawer and storage compartment.

9.3 Using the electric multifunction oven



The end of cooking display and the control knobs on the main oven **have no bearing** on the operation of the auxiliary oven.



9.3.1 Switching on the oven for the first time

The first time it is used, the oven may smoke or give off an acrid smell caused by oily residue from manufacturing that may give unpleasant odours or flavours to food. **Before putting food in the oven, heat to the maximum temperature for 30-40 minutes with the door closed and wait until the smoke or odour has stopped.**

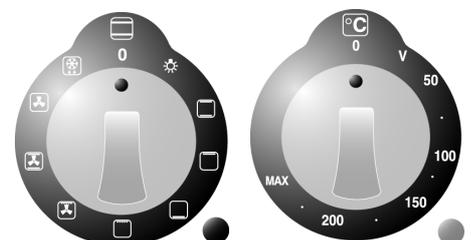



To prevent any steam in the oven from scalding, proceed as follows: turn the function switch knob to "0", or to function ; open the door in two stages: hold it partly open (**approx. 5 cm**) for 4-5 seconds, then open it completely.

Should you need to adjust the food, leave the door open for as short a time as possible to prevent the temperature inside the oven from lowering to such an extent as to jeopardise cooking.

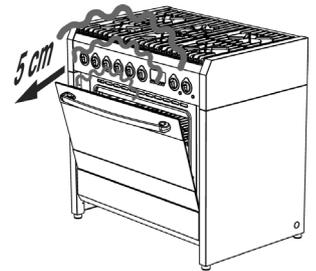

9.3.2 Traditional cooking

Turn the function switch knob to position  and the thermostat knob in correspondence with the required temperature value. For differentiated heating over or below the food, set the function selector switch to position  (hot above) or  (hot below). For more uniform heating throughout the oven, turn the function switch knob to position .



After preheating and putting the food in the oven an air flow between the upper side of the door and the lower side of the hob may be noticed. **In case that does not happen, switch off the appliance and contact the Technical Service immediately.**

9.3.3 Convection cooking

Turn the function switch knob to position ; turn the thermostat knob in correspondence with the required temperature value.

9.3.4 Cooking with the ventilated grill

Turn the function switch knob to position ; turn the thermostat knob in correspondence with the maximum temperature value (**MAX**).

9.3.5 Cooking with the grill + roasting spit

Turn the function switch knob to position ; turn the thermostat knob in correspondence with the maximum temperature value (**MAX**). The grill and spit operate at the same time, allowing for cooking on the spit.

9.3.6 Cooking with the roasting spit

If your oven model has a roasting spit, proceed as follows:

- Slide the meat to be cooked on the spit rod **A** and secure it with the adjustable forks.
- Hang the hook **B** at the top of the oven as shown in the figure.
- Place the spit rod **A** into the hole **C** in the oven casing; before closing the oven door, make sure that the rod **A** is correctly inserted into the hole **C** (insert the rod and turn it slightly back and forth).
- Hang the other end of the spit rod to the hook **B** (the pulley of the rod **A** is situated on the handle of the hook **B**).
- Close the oven door and activate the spit by turning the function selector knob to the  position.
- When cooking is completed, open the oven door and remove the spit rod using the plastic handle **D**, which is screwed into the base of the rod **A**.

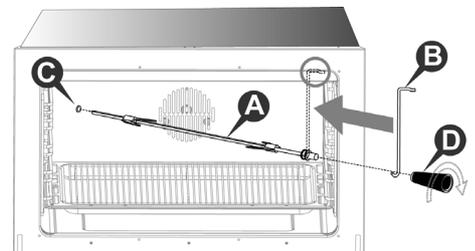

9.3.7 Defrosting

Turn the function switch knob to position , turn the thermostat knob to position "0": in this way the motor fan is activated, which moves the air inside the oven and encourages frozen food to defrost.

9.3.8 Switching off the oven

The oven is switched off by returning the thermostat knob to position "0".



9.4 Using the auxiliary oven with natural convection



The end of cooking display and the control knobs on the main oven **have no bearing** on the operation of the auxiliary oven.



The auxiliary oven with natural convection is equipped with:

- a heating element positioned on the base of the oven (at the bottom);
- a heating element positioned on the ceiling of the oven (at the top) + grill.



9.4.1 Switching on the auxiliary oven for the first time

The first time it is used, the auxiliary oven may smoke or give off an acrid smell caused by oily residue from manufacturing that may give unpleasant odours or flavours to food. **Before putting food in the oven, heat the auxiliary oven to the maximum temperature for 30-40 minutes with the door closed and wait until the smoke or odour has stopped.**

To start heating the auxiliary oven, select the temperature (from **60** to **MAX**) or the required function by turning the thermostat knob.

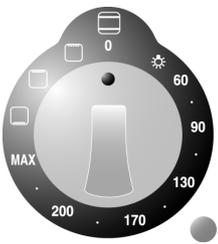

9.4.2 Cooking with the grill (auxiliary oven)

Turn the thermostat knob to position  and let the auxiliary oven preheat for approximately 5 minutes. For correct operations, position the grill shelf on the third guide from the bottom. It is however possible to vary the position of the grill shelf according to personal taste and different cooking requirements. Before putting food in the oven, allow it to preheat for 5 minutes. A cooling system prevents the control knobs from overheating.

9.4.3 Cooking with the spit (auxiliary oven)

Turn the thermostat knob to position  and let the auxiliary oven preheat for approximately 5 minutes. In the meantime, proceed as follows:

- insert the food on to the spit rod **A** taking care to hold it firm with the two forks **B**, and balancing it so as to avoid straining the gearmotor;
- place the pulley **C** of the spit rod onto the support **D** after introducing the opposite end into the hole **E**, until the coupling with the gearmotor **F** so that the rod rotates;
- pour a little water into the dripping pan and position it under the spit rod;
- monitor the cooking from time to time and check the spit rod is rotating correctly;
- at the end of the cooking, switch off the auxiliary oven by returning the thermostat knob to position "0";
- remove the spit rod from the auxiliary oven using the knob **G** and wearing an oven glove.

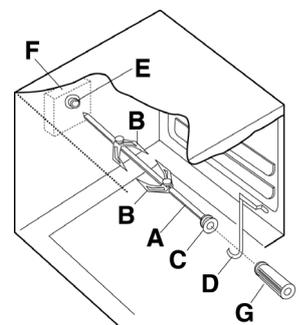

9.4.4 Switching off the auxiliary oven

The oven is switched off by returning the thermostat knob to position "0".



10. Cooking suggestions

10.1 Suggestions for using the hob burners correctly

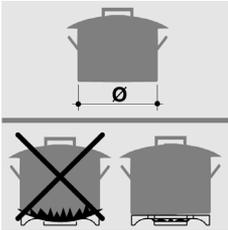

The diameter of the base of cooking recipients should fit the diameter of the burner used (see adjacent table). The burner flame must never be wider than the diameter of the recipient. Use recipients with a flat base. Where possible use pots with a lid, as this allows less power to be used. To reduce cooking times for vegetables, potatoes, etc., use little water.

Burner	Recipient diameter (in cm)
Rapid	from 24 to 26
Semi rapid	from 16 to 22
Auxiliary	from 8 to 14
Triple-ring	from 24 to 26
Fish kettle	from 16 to 35

10.2 Suggestions for using the fry-top / steak grill correctly

The **fry-top** griddle is smooth, whereas the **steak grill** is lined and can be used to obtain the typical rhomboidal pattern together with the delicious flavour of barbecue cooking. Foods cooked on the fry-top/steak grill have a special taste that does not require the excessive use of spices. It is possible to cook in different ways. For example, different foods, such as meat and fish, can be cooked at the same time. Before cooking meat, we recommend treating it with flavoured oil or marinating it for a few hours. A little tip: meat should always be salted after cooking on the griddle, so that its juices do not come out prematurely.

10.3 Suggestions for using the vitroceramic hob correctly

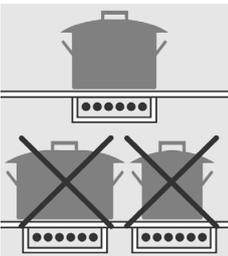

In order to obtain good efficiency and adequate energy consumption, it is essential to use only recipients that are suitable for electric cooking. The diameter of the base of the recipient must be the same as the diameter of the outline of the cooking area. Energy is wasted if they do not correspond. The base of the recipient must be very thick and perfectly flat. It should also be clean and dry, as should the glass on the hob. Do not use cast iron pots or pots with a rough base, as they may scratch the surface.

When using the vitroceramic hob, it must be thoroughly cleaned before switching on the heating elements. The glass may be scratched if pans are placed on abrasive residues. Any scratches do not however jeopardise the cooking procedure.

The ideal thickness for the base of the pans is:

- 2-3 mm in enamelled steel;
- 4-6 mm in stainless steel with double base.

Before cooking food with a high sugar content (e.g. jam), apply a protective product to the cooking surface to prevent it from being damaged if the food spits or boils over.

10.4 Suggestions for using the oven correctly



The oven allows to optimise cooking. It is possible to cook traditionally, with convection and with the grill.

The oven door should be completely closed for all types of cooking.



10.4.1 Traditional cooking

With this type of cooking, the heat comes from the top and the bottom. It is therefore preferable to use the central guides. If the cooking requires a hotter temperature from the bottom or from the top, use the lower or upper guides. Traditional cooking is recommended for all food that requires high cooking temperatures, or long brazing times. This system is also recommended when cooking with recipients made of terracotta, porcelain and similar materials.

10.4.2 Convection cooking

With this type of cooking, the food is heated by preheated air that is circulated in the oven thanks to a fan located on the rear wall of the oven. Heat rapidly and evenly reaches all parts of the oven, thus enabling different food to be cooked at the same time on different shelves. Humidity is eliminated from the air and the drier area prevents odours and flavours from being spread and mixed.

The possibility of cooking on more than one shelf allows you to cook many different dishes at the same time. Biscuits and mini pizzas can be cooked in three different baking tins. The oven, however, can also be used for cooking on a single shelf. The lower shelves can be used so that it is easier to monitor cooking.

Convection cooking is particularly convenient for bringing frozen food rapidly back to room temperature, for sterilising preserves or home-made fruit in syrup and, finally, for drying mushrooms or fruit.

10.4.3 Cooking with the grill

The heat comes from the top. Almost all meat can be grilled, with the exception of lean game and dishes such as meat-loaf. Meat and fish to be grilled should be lightly drizzled with oil and placed on the grid bars, which should be placed in the guides closest to or farthest away from the grill element, depending on the thickness of the meat, so as to avoid burning the surface and cooking too little inside.

Suitable for: relatively thin meat; toasted sandwiches.



Pour 1 or 2 glasses of water into the dripping pan to avoid smoke forming due to drops of juice or fat.

While cooking with the grill, the dripping pan should always be positioned in the 1st guide from the bottom.

10.4.4 Cooking with the ventilated grill

Using the combination of grill and fan .

This type of cooking allows the heat to penetrate gradually inside the food, even though the surface is directly exposed to the grill.

Suitable for: thicker meat; game-birds.

10.4.5 Cooking meat and fish

Meat to be cooked in the oven should weigh at least **1 kg**. Very tender red meat to be cooked rare (roast beef, fillet, etc.), or which should be well cooked on the outside and preserve all its juices on the inside, require cooking on high temperatures for a short time (**200-250°C**). White meat, game-birds and fish require cooking on low temperatures (**150-175°C**).

The ingredients for the sauce should only be placed in the baking tin if the cooking time is short, otherwise, they should be added in the last half hour. Meat can be placed on an ovenproof plate or directly on the grid bars, below which the dripping pan should be placed to collect the juice. Press the meat with a spoon to check if it is done. If it is firm, it is cooked.

At the end of the cooking, wait at least **15 minutes** before cutting the meat so as not to lose the juices. Before serving, plates can be warmed in the oven at minimum temperature.

10.4.6 Baking

Beaten mixtures must stick to the spoon because excess fluidity would prolong the cooking time. Sweets require moderate temperatures (generally between **150-200°C**) and require preheating (**approximately 10 minutes**). The oven door must not be opened until at least $\frac{3}{4}$ of the way through the cooking time.



10.4.7 Recommended cooking tables

Cooking times vary according to the nature, homogeneity and volume of the food. We recommend monitoring your first attempts and checking the results, as similar results are obtained by cooking the same dishes in the same conditions. The following three tables (I, II and III) provide guidelines.

TABLE OF CONVECTION AND TRADITIONAL COOKING TIMES (I)

TYPE OF COOKING	QUANTITY KG.	POSITION OF GUIDE FROM BOTTOM		TEMPERATURE °C		TIME IN MINUTES
		CONVECTION 	TRADITIONAL 	CONVECTION 	TRADITIONAL 	
BAKING						
WITH BEATEN MIXTURE, IN A TIN	1	1-3	2	175	200	60
WITH BEATEN MIXTURE, ON THE DRIPPING PAN	1	1-3	2	175	200	50
SHORT PASTRY, PIE BASE	0.5	1-3	3	175	200	30
SHORT PASTRY WITH MOIST FILLING	1.5	1-3	2	175	200	70
SHORT PASTRY WITH DRY FILLING	1	1-3	2	175	200	45
MIXTURE WITH NATURAL LEAVENING	1	1-3	1	175	200	50
SMALL CAKES	0.5	1-3	3	160	175	30
MEAT						
VEAL	1	2	2	180	200	60
BEEF	1	2	2	180	200	70
ENGLISH STYLE ROAST BEEF	1	2	2	220	220	50
PORK	1	2	2	180	200	70
CHICKEN	1-1.5	2	2	200	200	70
STEWES						
BEEF STEW	1	1	2	175	200	120
VEAL STEW	1	1	2	175	200	110
FISH						
FILLET, STEAK, COD, HAKE, SOLE	1	1-3	2	180	180	30
MACKEREL, TURBOT, SALMON	1	1-3	2	180	180	45
OYSTERS	1	1-3	2	180	180	20
TIMBALE						
PASTA TIMBALE	2	1-3	2	185	200	60
VEGETABLE TIMBALE	2	1-3	2	185	200	50
SWEET AND SAVOURY SOUFFLÉS	0.75	1-3	2	180	200	50
PIZZA AND CALZONE	0.5	1-3	2	200	220	30

- The times refer to cooking on one shelf only; for more than one shelf increase the time by **5-10'**.
- The cooking times do not include preheating which takes **approximately 15'**.
- When cooking on more than one shelf, the guides are given in the preferential position.
- For beef, veal, pork and turkey roasts, either with bone or rolled, increase the time by **20'**.

TABLE OF COOKING TIMES WITH GRILL AND VENTILATED GRILL (II)

TRADITIONAL GRILLING				
TYPE OF COOKING	QUANTITY KG.	POSITION OF GUIDE FROM BOTTOM	TEMPERATURE °C	TIME IN MINUTES
CHICKEN	1-1.5	3	MAX	30 PER SIDE
TOASTED SANDWICHES	0.5	4	MAX	5 PER SIDE
SAUSAGES	0.5	4	MAX	10 PER SIDE
PORK CHOPS	0.5	4	MAX	8 PER SIDE
FISH	0.5	4	MAX	8 PER SIDE
GRILLING WITH VENTILATED GRILL				
TYPE OF COOKING	QUANTITY KG.	POSITION OF GUIDE FROM BOTTOM	TEMPERATURE °C	TIME IN MINUTES
ROAST PORK	1.5	2	170	180
ROAST BEEF	1.5	3	220	60
CHICKEN	1.2	2	190	90

- The dripping pan for collecting cooking juices should always be positioned in the **1st guide from the bottom**.

TABLE OF DEFROSTING TIMES (III)

DEFROSTING			
TYPE OF FOOD	QUANTITY KG.	POSITION OF GUIDE FROM BOTTOM	TIME IN MINUTES
READY-TO-EAT DISHES	1	2	45
MEAT	0.5	2	50
MEAT	0.75	2	70
MEAT	1	2	110

- Defrosting at room temperature has the advantage of not modifying the flavour and appearance of food.



11. Cleaning and maintenance



Before cleaning or carrying out maintenance, switch off the power supply to the appliance and close the gas tap.



Do not clean the surfaces of the appliance when they are still hot. Do not use pressure or steam spray guns to clean the appliance.

11.1 Cleaning stainless steel surfaces



To clean and preserve the stainless steel surfaces and remove the toughest stains, always use specific products, provided **they do not contain chlorine-based abrasives or acid substances**, or a little warm vinegar.

Pour the product onto a damp cloth and wipe the steel surface. Rinse carefully and dry with a soft cloth or a piece of deerskin.

Do not under any circumstances use metallic sponges or sharp scrapers that may damage the surfaces. Only use non-scratch, non-abrasive sponges and, if necessary, wooden or plastic utensils.

11.2 Cleaning enamelled surfaces

Clean with a non-scratch, **non-abrasive** sponge dampened with soap and water. Grease stains can easily be eliminated with hot water or a product specifically made for cleaning enamel. Rinse carefully and dry with a soft cloth or a piece of deerskin.

Do not use products containing abrasives, scouring pads, steel wool or acid, which may spoil the surfaces. Do not leave acid or alkaline substances on the enamel (lemon juice, vinegar, salt, etc.).

11.3 Cleaning the knobs and the control panel

Clean the knobs and the control panel with a damp cloth.

11.4 Cleaning the grids and burners

To clean the grids and hob burners, remove them from their housing by lifting them upwards as shown in the figure, and immerse them in a solution of warm water and **non-abrasive** detergent for about ten minutes. Rinse and dry carefully.

Always check that none of the burner openings is clogged.

Be sure to refit the burner correctly, checking the flame is uniform.

We recommend carrying out this operation at least once a week and each time it is necessary.

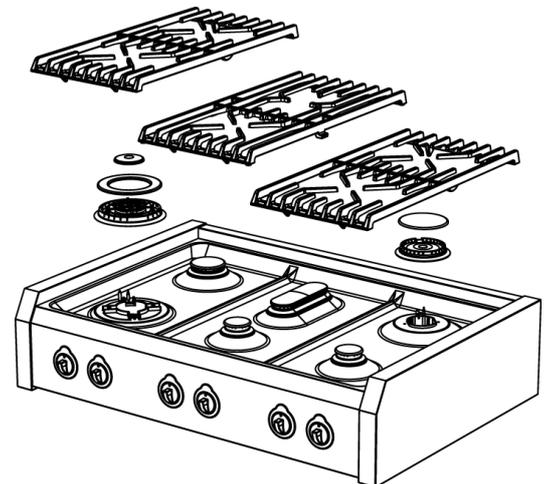



11.5 Cleaning the igniter plugs and thermocouples

In order for the igniter plugs and thermocouples to operate correctly, they must be kept clean at all times. Check them frequently and, if necessary, clean them with a damp cloth. Any dry residue should be removed with a toothpick or needle, **taking care not to damage the insulating ceramic part.**

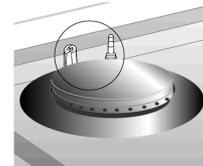

11.6 Cleaning the fry-top / steak grill

Any grease deposits on the fry-top/steak grill can be eliminated more easily when the griddle is still warm. If necessary, leave it to cool and soak for a few minutes. Finally, clean with warm salted water, dry with a tea cloth or kitchen roll.

After each use, the vitroceramic surface **V** underneath the fry-top/steak grill should also be cleaned. Any residue of meat or grease can be removed by proceeding as follows:

- remove the fry-top/steak grill from its housing;
- turn the knob to position **11**;
- after approximately **20-30 minutes**, even the toughest residue can easily be cleaned off the vitroceramic surface with a wooden spatula;
- switch off the heating and leave to cool, then clean the vitroceramic surface **V** with specific products;
- dry thoroughly and return the fry-top/steak grill to its working position.

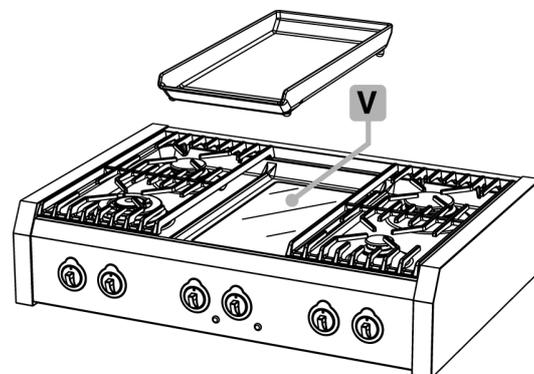

11.7 Cleaning the vitroceramic hob

The vitroceramic hob must be cleaned regularly, each time it is used if possible, when the latent heat lights are off.

Any light-coloured marks caused by aluminium-based pans can be removed with a damp cloth dipped in vinegar.

Any burnt residue left after cooking can be removed with a wooden spatula. Rinse with water and dry well with a clean cloth.

Do not under any circumstances use **abrasive or corrosive** detergents (e.g. powder products, oven sprays, stain-removers or metallic sponges).

Any grease deposits on the vitroceramic hob can be removed more easily by heating it for approximately **20-30 minutes** (knob in position **11**). Afterwards, this residue can be cleaned off with a wooden spatula. Allow the surface to cool, rinse with water and dry well with a clean cloth.

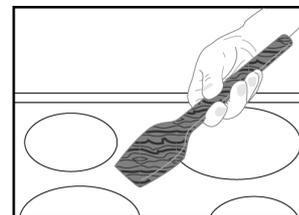
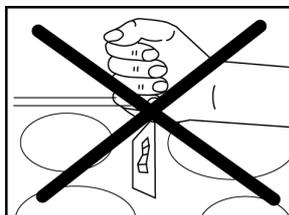

In the event that aluminium or plastic marks, sugar or food containing sugar melt on the cooking surface, **remove immediately** while the surface is still warm with a wooden spatula. This will prevent any damage to the surface.



The cooking surface of the vitroceramic hob is extremely resistant. It is not however unbreakable and may be damaged, above all by pointed or hard objects if dropped onto it with a certain force.
Warning! If any crack should appear on the hob, isolate the cooker from the main supply and do not use the appliance to avoid electrocution. Call Customer Services immediately.



11.8 Cleaning the oven

In order to preserve the oven well, it should be cleaned regularly, each time it is used if possible, **after leaving it to cool**: in this way it is possible to remove any residue more easily, preventing it from burning the next time the oven is used.

Clean the stainless steel parts and enamelled parts as described in the corresponding sections “11.1 Cleaning stainless steel surfaces” and “11.2 Cleaning enamelled surfaces”.

Take out all the removable parts and wash them separately. Rinse and dry thoroughly with a clean cloth.

11.8.1 Cleaning the oven walls

Never use detergent products to clean this type of oven.

The walls of the oven can be cleaned using white vinegar and wiped with a cloth dampened with water. Subsequently, heat the oven for at least one hour at **150°C** to facilitate cleaning. When the oven has cooled, wipe it again with a damp cloth.

11.8.2 Cleaning the oven door

We recommend always keeping the oven door clean. Use kitchen roll and on tougher dirt use a damp cloth and household detergent.



Spray products for cleaning the oven must not be used to clean the fan and the thermostat sensor inside the oven compartment.

11.9 Replacing the oven light bulb



Before carrying out maintenance, switch off the power supply to the appliance.

Proceed as follows:

- open the oven door;
- unscrew the glass safety cap anticlockwise; unscrew the bulb and replace it with another one for **high temperatures (300°C)** with the following characteristics:

Voltage: 230 V / 50 Hz

Power: 15 W

Attachment: E 14

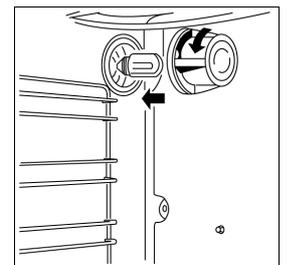

- Refit the glass cap and switch on the power. It is possible to check that the oven light is working even when the door is closed by turning the function switch knob to position ☀.



12. Special maintenance

Periodically, it is necessary to maintain or replace some parts that are subject to wear and tear. Specific instructions are given below for each type of maintenance.



Before carrying out maintenance, switch off the power supply to the appliance and close the gas tap.

12.1 Removing the oven door

The oven door can be completely removed to enable more thorough cleaning. Though this operation is possible, it should not be performed by everyone, as it requires the strength to hold up the door and a minimum of expertise to re-fit it. If you are not sure of being able to do this, we recommend that you clean the door without taking it off or, in special cases, that you contact the nearest authorised service centre.

To remove the door, proceed as follows:

- Open the oven door and release the safety catches of the hinges by turning the respective pins **A** (one for each hinge) backward.
- Partially close the door until there is no more load tension on the springs (the door will form an angle of about 30°).
- Using both hands, accompany the movement of the door towards closure and simultaneously lift it upward.
- Turn the lower part of the door towards the outside to free the hinges **B** from their seats.

If you need to remove any dry residues or dust deposited on the inner part of the windows, turn the door upside down as shown in the figure, slide a soft bottle brush into the spaces between the glass plates and brush gently.

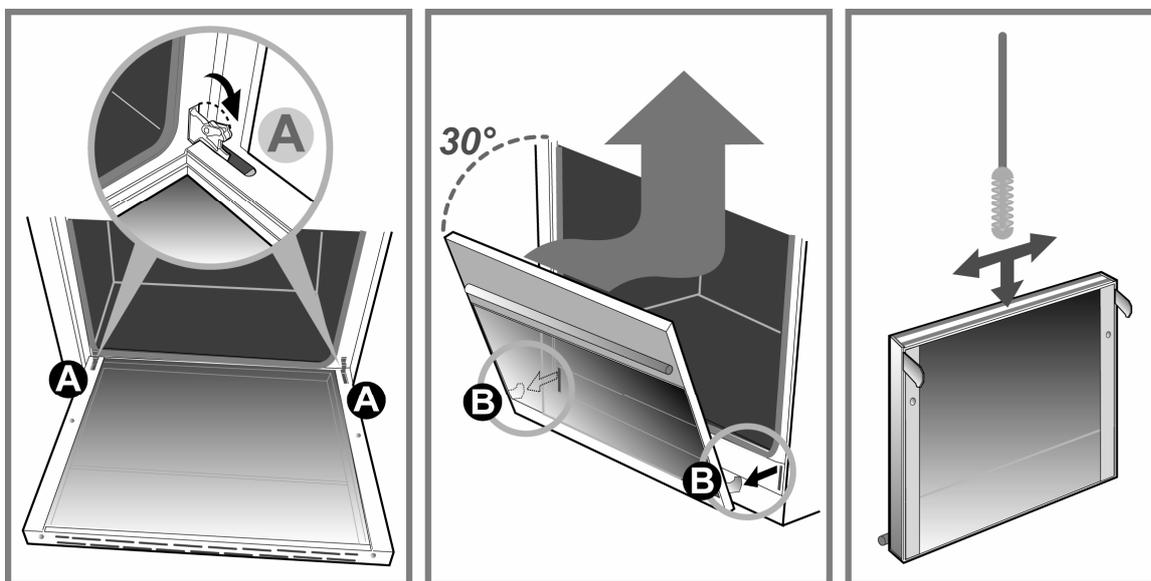

To re-fit the door, carry out the instructions given above in the inverse direction. When the hinges **B** are back in their seats, open the door all the way and re-fit the safety catches of the hinges, lowering the respective pins **A** (one for each hinge).

CAUTION: After re-fitting the door, **always** be sure to re-fit the hinge safety catches.





12.2 Removing the side rack-holder frames

The rack-holder frames can be removed to clean them separately and to facilitate cleaning the oven walls. The frames are hooked to the oven wall in the three points indicated by the arrows in the figure (detail 1).

- Press downward with your fingers as shown in detail 2 of the figure to release the frame from the upper pin.
- Lift the frame upward and take it out.

To re-fit proceed in the inverse direction. Set the lower part of the frame on the respective pins and press the upper part against the oven wall until it hooks onto the pin.

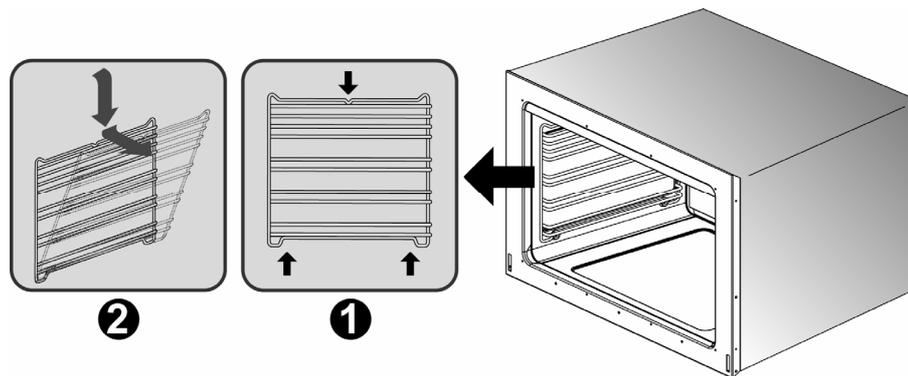

12.3 Removing and cleaning the inside oven fan

The inside fan of the ventilated oven may require periodic cleaning. To disassemble the fan proceed as follows:

- **Make sure that the power supply to the appliance is switched off.**
- Remove all inside components (dripping pan, shelves).
- Loosen and remove the four screws **A** from the cover panel.
- Remove the cover panel **B**.
- Use a coin to loosen the fixing nut **C** of the fan (this threading is inverse; to loosen turn clockwise).
- Remove the fan **D** and wash it by immersing it in warm water and dish detergent. **Never use abrasive or corrosive detergents, powdered products, or metal scrubbers.** Rinse the fan and dry it thoroughly.

Re-fit the fan and the cover by working in the inverse direction to the instructions for removal.

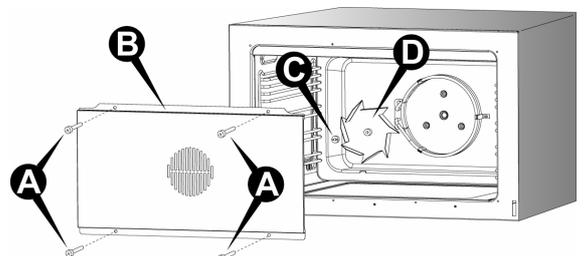

 **From the Electrolux Group. The world's No. 1 choice.**

The Electrolux Group is the world's largest producer of powered appliances for kitchen, cleaning and outdoor use. More than 55 million Electrolux Group products (such as refrigerators, cookers, washing machines, vacuum cleaners, chain saws and lawn mowers) are sold each year to a value of approx. USD 14 billion in more than 150 countries around the world.