

Airlines & Avionics Products
Honeywell International, Inc.
15001 N.E. 36 th Street
Redmond, WA 98052

MK XXII

Enhanced Ground Proximity Warning System for Rotorwing Aircraft

Installation Manual

060-4314-225 Rev C

Part Numbers:

965-1590-006

965-1590-008

965-1590-010

965-1590-011

Release Date: 12/14/00

Honeywell
MK XXII EGPWS Installation Manual

This document is an unpublished work. Copyright ©2000 Honeywell, International, Inc. All rights reserved.

This document and all information and expression contained herein are the property of Honeywell International Inc., and is provided to the recipient in confidence on a “need to know” basis. Your use of this document is strictly limited to a legitimate business purpose requiring the information contained therein. Your use of this document constitutes acceptance of these terms.

Honeywell
MK XXII EGPWS Installation Manual

Typed names constitute approval signatures. Actual signatures are on file at Honeywell in Redmond, WA.

DRAWN	Dennis Martin	12/8/00
CHECK	Sara Stark	12/8/00
ENGR	Dennis Martin	12/8/00
MFG		
QA		
APVD	Dennis Martin	12/8/00
APVD		

REVISIONS				
SH	REV	DESCRIPTION	DATE	APPROVED
ALL	A	Added Software -008 Revisions. Reason: 01 Severity: 10	8/9/01 8/9/01	S. Wright D. Martin
ALL	B	Added Software -010 Revisions. Reason: 01 Severity: 10	3/22/02 3/22/02	D. Martin R Gilliland
ALL	C	Added Software -011 Revisions. Reason: 01 Severity: 10	6/07/02 6/7/02	D Martin T Curtis

Honeywell
MK XXII EGPWS Installation Manual

TABLE OF CONTENTS

SECTION I – GENERAL INFORMATION.....	16
1.1 INTRODUCTION	16
1.2 APPLICABILITY	16
1.3 HOW TO USE THIS DOCUMENT	16
1.4 REFERENCE DOCUMENTS	17
1.5 DESCRIPTION OF EQUIPMENT.....	18
1.5.1 MK XXII EGPWS Computer.....	19
1.5.2 MK XXII EGPWS Configuration Module	19
1.5.3 GPS Antenna.....	19
1.5.4 OAT Sensor.....	19
1.5.5 Smart Cable (PCMCIA Interface).....	20
1.6 TECHNICAL CHARACTERISTICS	21
1.7 UNITS SUPPLIED	22
1.7.1 MK XXII EGPWS.....	22
<i>note 1: -0XX defines the Application software version.....</i>	<i>22</i>
1.7.2 Configuration Module.....	22
1.7.3 Smart Cable (PCMCIA Interface).....	22
1.8 INSTALLATION AND ACCESSORIES KITS	24
1.8.1 MK XXII EGPWS Installation Kits	24
1.8.2 RS-232 Cable	24
1.8.3 Smart Cable	24
1.8.4 Terrain Database Cards	25
1.8.5 Flight History Card	25
1.9 ACCESSORIES REQUIRED BUT NOT SUPPLIED.....	25
1.9.1 ARINC 453 Terrain Display wiring.....	25
1.9.2 GPS Antenna & cable	26
1.9.3 Circuit Breaker	26
1.9.4 Annunciators & Switch/Annunciators.....	26
1.9.4.1 GPWS Warning (red) P/TEST; switch/annunciator assembly	26
1.9.4.2 GPWS Caution (amber) G/S CANCLD switch/annunciator assembly.....	27
1.9.4.3 LOW ALT / ON switch/annunciator assembly.....	27
1.9.4.4 TERR INHIB / ON switch/annunciator assembly	27
1.9.4.5 AUDIO INHIBIT / ON switch/annunciator assembly	27
1.9.4.6 GPWS INOP / TERR INOP annunciator assemblies.....	27
1.9.4.7 TERR DISPLAY / ON switch/annunciator assemblies	27
1.10 COCKPIT SPEAKER (OPTIONAL).....	27
1.11 TOOLS REQUIRED	28
1.11.1 Crimping Tool - P1, P2, P3	28
1.11.2 Contact Positioner - P1, P2, P3.....	28

Proprietary notice on title page applies

Honeywell
MK VI MK VIII EGPWS Installation Design Guide

1.11.3 Insertion/Removal Tool - P1, P2, P3	28
1.11.4 Spare Contacts - P1, P2, P3	28
1.12 LICENSE REQUIREMENTS	28
SECTION II - INSTALLATION	33
2.1 INTRODUCTION	33
2.2 UNPACKING AND INSPECTING THE EQUIPMENT	33
2.3 EQUIPMENT INSTALLATION	33
2.3.1 General	33
2.3.2 MK XXII Computer Location.....	34
2.3.3 MK XXII Computer Installation.....	34
2.3.4 Configuration Module Location	35
2.3.5 Configuration Module Installation	35
2.3.6 GPS Antenna location.....	44
2.3.7 GPS Antenna Installation	44
2.3.8 OAT Sensor Location.....	44
2.3.9 OAT Sensor Installation.....	44
2.3.10 Cockpit Annunciators / Switches.....	44
2.3.10.1 Description	45
2.3.10.2 Location.....	46
2.3.10.3 Inhibit Switch Functions and Selection	48
2.3.10.3.1 Terrain Inhibit	48
2.3.10.3.2 Audio Inhibit (Timed)	48
2.3.10.3.3 Audio Inhibit (Not Described Above).....	48
2.3.10.3.4 Low Altitude Mode	48
SECTION III – SYSTEM PLANNING	57
3.1 INTRODUCTION	57
3.2 SYSTEM WIRING/ ELECTRICAL INTERFACES.....	57
3.2.1 Primary Power Input	57
3.2.2 Chassis Ground	57
3.2.3 GPS Antenna.....	58
3.2.4 Analog and Digital Inputs.....	58
3.2.5 Discrete Inputs.....	58
3.2.6 Serial Outputs	58
3.2.7 Audio Output.....	59
3.2.8 Discrete Outputs	59
3.2.9 Configuration Module.....	59
3.3 CONFIGURABLE INTERFACES	60
3.3.1 Category 1 - Aircraft / Mode Type Select.....	60
3.3.1.1 Aircraft / Mode Type	60
3.3.1.2 Instructions	60
3.3.1.3 Generic Helicopter with and without Torque.....	60

Proprietary notice on title page applies

Honeywell
MK VI MK VIII EGPWS Installation Design Guide

3.3.2 Category 2 – Air Data Input Select.....	61
3.3.2.1 Instructions	61
3.3.2.2 Examples	62
3.3.2.3 Analog altitude and 500 ohm OAT	62
3.3.2.4 Digital – ARINC 429 (Cat. 2 ID 5, 1, 6)	63
3.3.2.5 Digital –ARINC 575 (Cat. 2 ID 2)	64
3.3.2.6 Shadin 2000 (Cat. 2 ID 10)	65
3.3.2.7 Digital – ARINC 429 Dual IOC Buses (Cat. 2. ID 255)	66
3.3.3 Category 3 – Position Input Select	67
3.3.3.1 Instructions	67
3.3.3.2 ARINC 743 Format	67
3.3.3.Examples	68
3.3.3.1 ARINC 429 BUS (Cat. 3 ID 0,1,4,5).....	68
3.3.3.2 RS-232 Transmit-Receive, 9600 baud (Cat. 3 ID 3)	68
3.3.3.3 Dual ARINC 429 BUS (Cat. 3 ID 255).....	69
3.3.4 Category 4 – Altitude Callouts	70
3.3.4.1 Instructions	70
3.3.5 Category 5 – Audio Menu Select	71
3.3.5.1 Instructions	71
3.3.6 Category 6 – Terrain Display Select	72
3.3.6.1 Instructions	72
3.3.6.2 TAD Selection	72
3.3.6.3 Terrain Display Configuration Group.....	73
3.3.6.4 Display Input Control Group	75
3.3.6.5 Output 429 Bus Group.....	75
3.3.6.6 Example.....	75
3.3.7 Category 7 – Options Select Group #1	81
3.3.7.1 Instructions	81
3.3.7.2 Steep Approach (Not Available in the Mk XXII).....	81
3.3.7.3 TA&D Alternate Pop-up.....	81
3.3.7.4 Peaks Mode	82
3.3.7.5 Obstacle Awareness.....	82
3.3.7.6 Bank Angle Callout Enabling.....	82
3.3.7.8 WOW Reversal.....	83
3.3.7.9 GPS Altitude Reference.....	83
3.3.8 Category 8 – Radio Altitude Input Select.....	84
3.3.8.1 Instructions	84
3.3.8.2 Example.....	84
3.3.8.3 Digital Radio Altitude Interface	84
3.3.8.4 Analog Radio Altitude Interface.....	85
3.3.9 Category 9 – Navigation Inputs Select	86
3.3.9.1 Instructions	86
3.3.9.2 Example.....	87

Proprietary notice on title page applies

Honeywell
MK VI MK VIII EGPWS Installation Design Guide

3.3.9.3 Analog Glideslope Interface (cat. 9 ID 0,1,5)	87
3.3.9.4 Digital Glideslope/Localizer Interface	88
3.3.9.5 Dual Glideslope Receiver	88
3.3.10 <i>Category 10 – Attitude Input Select</i>	89
3.3.10.1 Attitude Signals	89
3.3.10.2 Instructions	89
3.3.10.3 Example	90
3.3.10.4 Analog Roll Angle (Synchro).....	90
3.3.10.5 Digital ARINC 429 High Speed.....	91
3.3.11 <i>Category 11 – Heading Input Select</i>	92
3.3.11.1 Instructions	92
3.3.11.2 Magnetic Heading.....	92
3.3.11.3 Example.....	93
3.3.11.3.1 Analog Heading (Synchro) (CAT. 11 ID 0)	93
3.3.11.3.2 Digital ARINC 429 High Speed	94
3.3.12 <i>Category 12 – Windshear Input Select</i>	95
3.3.12.1 Instruction.....	95
3.3.13 <i>Category 13 – Input / Output Discrete Type Select</i>	96
3.3.13.1 Instruction.....	96
3.3.13.2 Input/Output Discretes	96
3.3.13.3 Audio Inhibit Discrete	97
3.3.13.4 Landing Gear Discrete.....	97
3.3.13.5 Weight ON Wheels (WOW) Discrete	97
3.3.13.6 Glideslope Cancel Discrete	98
3.3.13.7 Mode 6 Low Volume Discrete	98
3.3.13.8 Autopilot Engaged Discrete	98
3.3.13.9 Terrain Awareness Inhibit	99
3.3.13.10 Self Test Discrete	99
3.3.13.11 Glideslope Inhibit Discrete.....	99
3.3.13.12 Timed Audio Inhibit Discrete.....	100
3.3.13.13 Low Altitude Mode Select Discrete	100
3.3.13.14 Output Discretes.....	100
3.3.13.15 Lamp Format	100
3.3.13.16 GPWS INOP Discrete	101
3.3.13.17 TAD INOP Discrete	101
3.3.13.18 GPWS Warning Discrete.....	101
3.3.13.19 GPWS Alert Discrete	101
3.3.13.20 Glideslope Cancel Discrete	101
3.3.13.21 TCAS Inhibit Discrete.....	101
3.3.13.22 Terrain Display Select #1 & #2 Discrete.....	102
3.3.13.23 Timed Audio Inhibit Discrete.....	102
3.3.13.24 Low Altitude Mode Discrete	102
3.3.14 <i>Category 14 – Audio Output Level</i>	104

Proprietary notice on title page applies

Honeywell
MK VI MK VIII EGPWS Installation Design Guide

3.3.14.1 Instructions	104
3.3.15 <i>Category 15, Autorotation Threshold</i>	105
3.3.15.1 Instruction.....	105
SECTION IV – CONFIGURATION MODULE PROGRAMMING AND REGIONAL TERRAIN	
DATABASE LOADING.....	109
4.1 INTRODUCTION	109
4.2 HARNESS CHECKOUT AND POWER CHECK	109
4.3 UNIT INSTALLATION	109
4.4 EGPWC INITIALIZATION AND CONFIGURATION	109
4.4.1 <i>RS-232 Communication with the MK XXII EGPWS</i>	109
4.4.2 <i>EGPWC Front Panel Test Connector</i>	110
4.4.3 <i>WinVIEWS</i>	110
4.4.4 <i>WinVIEWS Operation</i>	111
4.5 CONFIGURATION MODULE PROGRAMMING	111
4.5.1 <i>CUW and CMR Commands</i>	113
4.5.2 <i>Configuration Module Reprogramming</i>	114
4.6 REGIONAL TERRAIN DATABASE LOADING	115
4.6.1 <i>Effectivity</i>	115
4.6.2 <i>Description</i>	115
4.6.3 <i>Approval</i>	115
4.6.4 <i>Material – Cost and Availability</i>	116
4.6.5 <i>Accomplishment Instructions</i>	117
4.6.6 <i>Verification of the Terrain Database Version</i>	118
SECTION V – CERTIFICATION	124
5.1 INTRODUCTION	124
5.2 CERTIFICATION PROCEDURE	124
5.2.2 <i>Equipment Location</i>	124
5.2.3 <i>FAA Requirements</i>	124
5.2.4 <i>Ground Test</i>	124
5.2.5 <i>Flight Manual Revision</i>	124
5.2.6 <i>Flight Test</i>	125
5.2.7 <i>Pilots Guide</i>	125
5.2.8 <i>Failure Modes, Effects, and Safety Analysis</i>	125
5.2.9 <i>Existing STC's</i>	125
APPENDIX A.....	127
CUSTOMER WORKSHEET	127
APPENDIX B.....	139
SAMPLE WIRING DIAGRAMS.....	139

Proprietary notice on title page applies

Honeywell
MK VI MK VIII EGPWS Installation Design Guide

APPENDIX C.....	143
WINVIEWS OPERATION INSTRUCTIONS	143
APPENDIX D.....	149
VENDOR DRAWINGS.....	149
D 1-0 VENDOR CONTACT INFORMATION	151
D1-1 EDMO.....	153
D1-2 EMTEQ.....	154
GPS - RF Cable Sets.....	154
TABLE 2	156
<u>Table 2.A.1 Connectors (for TFLX cable series) - GPS</u>	156
TABLE 2 (continued).....	157
<u>Table 2.B.1 Connectors (for PFLX cable series) - GPS</u>	157
TOOL FRAME AND DIE PART NUMBERS.....	158
<u>INSTALLATION CONSIDERATIONS:</u>	159
D1-3 Aerospace Optics	160
AEROSPACE OPTICS INC.....	160
LED LIGHTING	160
INTRODUCTION	166
E 1 PART NUMBER.....	166
E 2 PURPOSE.....	166
E 3 SYSTEM OVERVIEW	166
E 4 ELECTRICAL INTERFACE	167
E 4.1 Introduction	167
E 4.2 Signal Interfaces	167
E 4.2.1 Grounds	167
E 4.2.2 Primary Power Input	167
E 4.2.3 DC Analog Inputs	168
E 4.2.7 AC Analog Inputs.....	170
E 4.2.9 ARINC 429/575 Digital Serial Bus Inputs	172
E 4.2.9.1 RS-232 / RS-422 Digital Serial Bus Inputs	173
E 4.2.10 Discrete Inputs	174
E 4.2.11 Configuration Module Interface	175
E 4.2.12 GPS Antenna Input	175
E 4.2.13 OAT Voltage Reference Output.....	176
E 4.2.14 Lamp Driver Outputs	176
E 4.2.16 Audio Outputs	176
E 4.2.17 ARINC Digital Serial Output Busses	177

Proprietary notice on title page applies

Honeywell
MK VI MK VIII EGPWS Installation Design Guide

E 4.2.17.1	ARINC 429 Output Bus.....	177
E 4.2.17.2	ARINC 453 Output Bus.....	178
E 4.2.18	FRONT PANEL TEST INTERFACE.....	178
E 4.2.18.1	RS-232 MAINTENANCE PORT (SERIAL PORT 4).....	178
E 4.2.18.2	PCMCIA / SmartCable Port	179
E 4.2.18.3	GSE Present Discrete Input.....	179
E 4.2.19	FRONT PANEL STATUS INDICATORS	179
E 5	AIRCRAFT APPLICATION DATA	180
E 5.1	CONFIGURATION TYPES.....	180
E 5.2	CONFIGURATION SELECTION	180
E 5.3	Configuration Selection Tables.....	182
E 5.3.1	Category 1, Aircraft / Mode Type Select.....	183
E 5.3.2	Category 2, Air Data Input Select.....	189
E 5.3.3	Category 3, Position Input Select	195
E 5.3.4	Category 4, Altitude Callouts	199
E 5.3.5	Category 5, Audio Menu Select.....	201
E 5.3.6	Category 6, Terrain Display Select.....	202
E 5.3.7	Category 7, Options 1 Select	231
E 5.3.8	Category 8, Radio Altitude Input Select.....	233
E 5.3.9	Category 9, Navigation Input Select.....	236
E 5.3.10	Category 10, Attitude Input Select	238
E 5.3.11	Category 11, Heading Input Select.....	240
E 5.3.12	Category 12, Windshear Input Select.....	241
E 5.3.13	Category 13, Input / Output Discrete Type Select	242
E 5.3.14	Category 14, Audio Output Level	245
E 5.3.15	Category 15, Autorotation Threshold.....	246
E 6	CONNECTOR INTERFACE	247
E 6.1	PINOUT FOR FRONT CONNECTORS SORTED BY PIN NUMBER	247
E 7	DEFINITIONS	252

Honeywell
MK XXII EGPWS Installation Manual

SECTION I
GENERAL INFORMATION

Honeywell
MK XXII EGPWS Installation Manual

SECTION I – GENERAL INFORMATION

SECTION I – GENERAL INFORMATION.....	16
1.1 INTRODUCTION	16
1.2 APPLICABILITY	16
1.3 HOW TO USE THIS DOCUMENT	16
1.4 REFERENCE DOCUMENTS	17
1.5 DESCRIPTION OF EQUIPMENT.....	18
1.5.1 MK XXII EGPWS Computer.....	19
1.5.2 MK XXII EGPWS Configuration Module	19
1.5.3 GPS Antenna.....	19
1.5.4 OAT Sensor.....	19
1.5.5 Smart Cable (PCMCIA Interface).....	20
1.6 TECHNICAL CHARACTERISTICS	21
1.7 UNITS SUPPLIED	22
1.7.1 MK XXII EGPWS.....	22
<i>note 1: -0XX defines the Application software version.....</i>	<i>22</i>
1.7.2 Configuration Module.....	22
1.7.3 Smart Cable (PCMCIA Interface).....	22
1.8 INSTALLATION AND ACCESSORIES KITS	24
1.8.1 MK XXII EGPWS Installation Kits	24
1.8.2 RS-232 Cable.....	24
1.8.3 Smart Cable	24
1.8.4 Terrain Database Cards	25
1.8.5 Flight History Card	25
1.9 ACCESSORIES REQUIRED BUT NOT SUPPLIED.....	25
1.9.1 ARINC 453 Terrain Display wiring.....	25
1.9.2 GPS Antenna & cable	26
1.9.3 Circuit Breaker.....	26
1.9.4 Annunciators & Switch/Annunciators.....	26
1.9.4.1 GPWS Warning (red) P/TEST; switch/annunciator assembly	26
1.9.4.2 GPWS Caution (amber) G/S CANCLD switch/annunciator assembly.....	27
1.9.4.3 LOW ALT / ON switch/annunciator assembly.....	27
1.9.4.4 TERR INHIB / ON switch/annunciator assembly	27
1.9.4.5 AUDIO INHIBIT / ON switch/annunciator assembly.....	27
1.9.4.6 GPWS INOP / TERR INOP annunciator assemblies.....	27
1.9.4.7 TERR DISPLAY / ON switch/annunciator assemblies	27
1.10 COCKPIT SPEAKER (OPTIONAL).....	27
1.11 TOOLS REQUIRED	28
1.11.1 Crimping Tool - P1, P2, P3	28
1.11.2 Contact Positioner - P1, P2, P3.....	28
1.11.3 Insertion/Removal Tool - P1, P2, P3	28
1.11.4 Spare Contacts - P1, P2, P3	28

Honeywell
MK XXII EGPWS Installation Manual

1.12 LICENSE REQUIREMENTS..... 28

SECTION I – GENERAL INFORMATION

1.1 Introduction

The Honeywell MK XXII Enhanced Ground Proximity Warning System (MK XXII EGPWS) provides alerts and warnings to prevent controlled flight into terrain (CFIT).

This Installation Manual must be used in conjunction with the Interface Description Document (Appendix E) for the MK XXII Enhanced Ground Proximity Warning System (MK XXII EGPWS) to select features and design the installation for this system.

It is assumed that the user of this document is familiar with avionics installation practices and helicopter systems associated with the installation and operation of the MK XXII EGPWS. It also assumes access to pertinent aircraft wiring diagrams, modification records and manuals.

The information contained herein, together with general procedures outlined in FAA AC.43.13 must be followed carefully to assure a safe, electrically sound, certifiable and operational installation.

The contents of this document are for information and reference only and must not be construed as formal FAA approved work authorization.

1.2 Applicability

This manual is applicable only to MK XXII EGPWS computers with the following part number:

MK XXII 965-1590-0XX

Part numbers 965-1590-0XX include an internal GPS card.

1.3 How To Use This Document

Section 1 provides a system overview.

Section 2 provides mechanical installation and location information.

Section 3 provides information and instructions for selecting required features of the EGPWS.

Section 4 provides Configuration Module programming instructions.

Section 5 provides certification requirements.

Appendix A Customer Worksheet.

Appendix B Sample Wiring Diagrams.

Appendix C provides WinViews operation instructions.

Appendix D Vendor drawings.

Appendix E Interface Description Document

Honeywell
MK XXII EGPWS Installation Manual

1.4 Reference Documents

Following is a list of Honeywell reference documents:

965-1590-601	Product Specification for the MK XXII Enhanced Ground Proximity Warning System (EGPWS)
993-1176-401	Interface Control Document (ICD) for the MK VI/VIII/XXII Enhanced Ground Proximity Warning System
965-1590-206	Outline, MK XXII EGPWC
060-4326-000	EGPWS Terrain Database Airport Coverage List
060-4314-009	Generic RWFM Supplement For EGPWS
060-4314-200	Mk XXII Helicopter-Enhanced GPWS Pilot's Guide
060-4314-006	General Flight Test Procedure
060-4167-167	Installation Ground Test Procedure for the Mk XXII EGPWS for Rotary Wing Aircraft
060-4314-002	Failures Modes, Effects, and Safety Analysis
060-4314-011	Line Maintenance Manual

Honeywell
MK XXII EGPWS Installation Manual

1.5 Description of Equipment

The MK XXII EGPWS is a rack mount ground proximity warning (GPWS) and terrain display (TAWS) computer. Some of the system features include:

- ◆ Basic Helicopter Ground Proximity Warning Modes 1-5
- ◆ Mode 6 Altitude, Bank Angle, and Tail Strike Callouts
- ◆ Terrain and Obstacle Awareness alert and display
- ◆ Terrain map with runways
- ◆ Internal GPS card
- ◆ Front loading updateable database
- ◆ External Configuration Module
- ◆ Internal heater blanket for operation outside of the heated area of the aircraft



Fig 1.0 MK XXII EGPWC

Honeywell
MK XXII EGPWS Installation Manual

1.5.1 MK XXII EGPWS Computer

The MK XXII EGPWS computer is available under P/N 965-1590-0XX with internal GPS. The MK XXII EGPWS computer is intended for Helicopters and provides a mixture of analog and digital interfaces. The type of supported displays is limited and includes some EFIS displays. The terrain database included with the MK XXII EGPWS computer are North America, South America, Europe, Eastern Europe, Africa, Asia, Pacific, South Pacific, and Middle East regions and are comprised of terrain data (6 arc second where available), all known airports, many heliports and man-made obstacles (North America only).

1.5.2 MK XXII EGPWS Configuration Module

The MK XXII EGPWS Configuration Module is available under P/N 700-1710-001 (Included in Installation Kits, see section 1.8). The MK XXII EGPWS uses a Configuration Module installed in the aircraft wiring to store aircraft/EGPWS interface configuration. Specifically, the module comes prewired and replaces part of the backshell of the (P2) connector that plugs into the front of the MK XXII computer. The Configuration Module is read by the EGPWS only during power up. The configuration is copied into Non Volatile Memory (NVM) of the EGPWS. The Configuration Module is programmable via an RS-232 interface with the EGPWS. The contents of the Configuration Module can also be read back via the same RS-232 interface.

1.5.3 GPS Antenna

EGPWS installations using the internal GPS require an active GPS antenna and cabling. The GPS antenna should meet the following qualifications:

Frequency:	1575.42 MHz
Impedance:	50 ohms
Gain:	33dB max, 26.5 dB preferred
Power:	5 VDC
Qualification:	TSO C129 or C129a or C144

The following GPS antennas are found to be compatible with the EGPWS internal GPS card. Other GPS antennas may be found compatible, contact EGPWS engineering for assistance. It is the responsibility of the OEM or owner/operator (and ultimately the regulatory authorities) to assess the antenna acceptance criteria relative to ARINC, MIL, or other specifications.

King KA 91	P/N 071-01545-0200	TSO-C129
King KA 92	P/N 071-01553-0200	TSO-C129
Sensor Systems	P/N S67-1575-52	TSO-C129, ARINC 743A
Sensor Systems	P/N S67-1575-133	TSO-C129a, ARINC 743A

1.5.4 OAT Sensor

The OAT sensor is available from Computer Instruments Corp. (CIC) P/N 05257. The EGPWS uses a separate OAT sensor (Outside Air Temperature) to measure outside air temperature on

Honeywell
MK XXII EGPWS Installation Manual

aircraft that do not have another compatible source of outside air temperature. Outside Air Temperature is used by the EGPWS along with pressure altitude in computing Geometric Altitude. If Outside Air Temperature is not available, Geometric Altitude is computed using pressure altitude with a corresponding reduction in accuracy.

Geometric Altitude is computed by the EGPWS to reduce or eliminate errors potentially induced in corrected barometric altitude by temperature extremes, non-standard altitude conditions, and altimeter miss-sets. Geometric Altitude also allows continuous EGPWS operation in QFE environments without crew intervention.

1.5.5 Smart Cable (PCMCIA Interface)

The EGPWS Smart Cable (part number 951-0386-001) is a removable PCMCIA card interface. The Smart Card is compatible with any Honeywell supplied EGPWS PCMCIA style cards. The purpose of the Smart Cable in the EGPWS system is for upload of software and databases and also for download of EGPWS Flight History. The Smart Card loading operation will closely emulate that of an ARINC 615 Data Loader.

Honeywell
MK XXII EGPWS Installation Manual

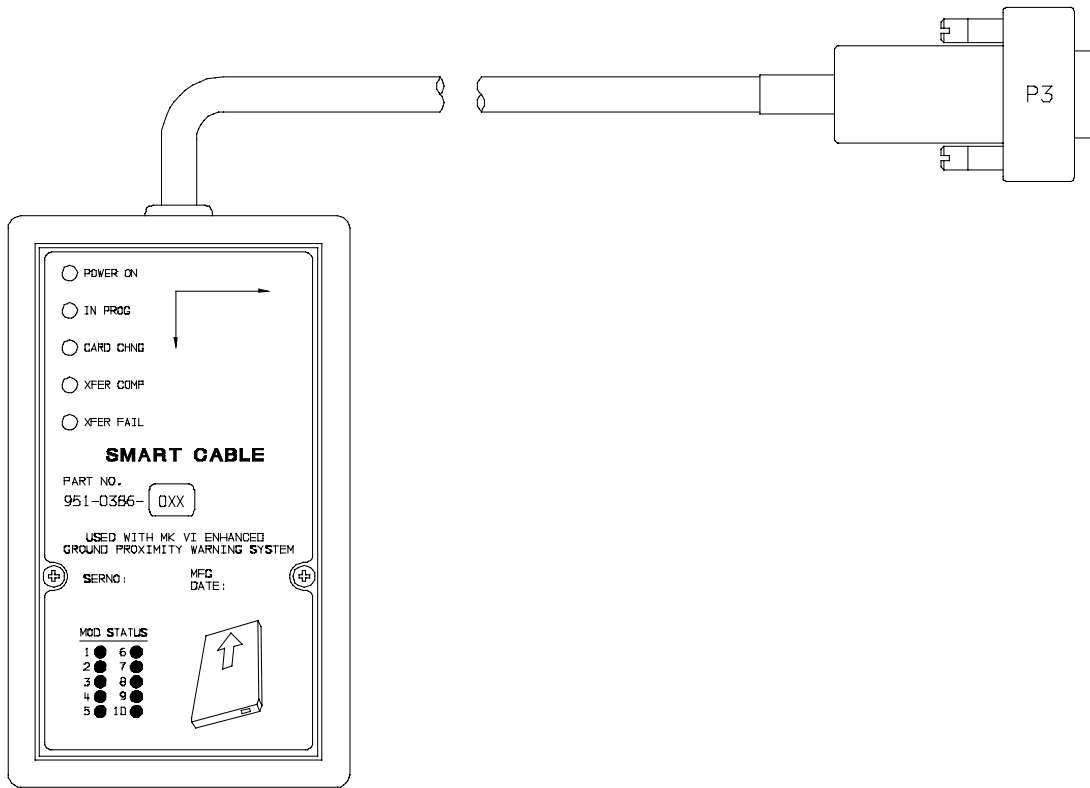

FIGURE 1-1 MK XXII EGPWS SMART CABLE

1.6 Technical Characteristics

MK XXII EGPWS	
TSO Compliance:	TSO-C92c, TSO-C151a, class A
Physical size (HxWxD):	6.20" x 3.04" x 10.30"
Weight:	3.9 pounds maximum
Mounting:	Standard 3 inch King Radio rack
Temperature (operational):	-55°C to +70°C (F2)
Altitude range:	55,000 feet (F2)
Cooling:	No cooling necessary
Shock:	No shock mounting required
Power Consumption (28 VDC):	3 Amps 9 watts – no warning +7 watts – with warning over 8 ohm speaker +3 watts – with GPS card +49 watts – with heater blanket on
Configuration Module	
TSO Compliance:	same as MK XXII EGPWS

Honeywell
MK XXII EGPWS Installation Manual

Physical size:	2.68" x 1.51" x 0.32" (fits Positronic connector backshell)
Weight:	<1 pound with connector and backshell
Mounting:	Mounts to Positronic connector backshell
Temperature (operational):	same as MK XXII EGPWS
Altitude range:	same as MK XXII EGPWS
Cooling:	No cooling necessary
Shock:	No shock mounting required
Power Consumption (5 VDC):	from MK XXII EGPWS

GPS Antenna Sensor

See Manufacturer's specifications Appendix D.

OAT Sensor

See Manufacturer's specifications Appendix D.

1.7 Units Supplied

1.7.1 MK XXII EGPWS

The MK XXII EGPWS The part number for the units is as follows:

965-1590-0XX with Internal GPS card

note 1: -0XX defines the Application software version

1.7.2 Configuration Module

The MK XXII EGPWS Configuration Module is available in one version. When ordering the Configuration Module, order part number 700-1710-001.

1.7.3 Smart Cable (PCMCIA Interface)

The MK XXII EGPWS Smart Cable is available in one version. The Smart Cable is used for Line Maintenance, **only one Smart Cable is required for an installation house or operator**. When ordering the Smart Cable, order part number 951-0386-001.

Honeywell
MK XXII EGPWS Installation Manual

Honeywell
MK XXII EGPWS Installation Manual

1.8 Installation and Accessories Kits

NOTE: Not all installation kits are immediately available, contact Honeywell Order Administration (425-885-8719) for availability.

1.8.1 MK XXII EGPWS Installation Kits

(A) New EGPWS installation with OAT and Internal GPS

The MK XXII EGPWS Installation Kit #1, P/N 755-7013-001, contains the following parts:

Vendor Name	Vendor P/N	Description	QTY	UM	Honeywell P/N
Positronic Ind.	DD78F1OJVLC-15	P1 connector	1	EA	440-1158-009
Positronic Ind.	RD50F1OJVLC-15	P2 connector	1	EA	440-1233-001
Amphenol	79075	GPS Antenna connector	1	EA	440-1239-001
Honeywell	700-1710-001	Configuration Module	1	EA	700-1710-001
Bendix/King	071-04003-0002	Computer Mounting Tray	1	EA	405-0383-001
CIC	05257	OAT Sensor	1	EA	107-1049-001
CIC	05257-TOMK	OAT mounting Kit	1	EA	107-1049-002
CIC	05257-TPIK	OAT Connector Kit	1	EA	107-1049-003

(B) New EGPWS installation with Internal GPS

The MK XXII EGPWS Installation Kit #5, P/N 755-7013-005, contains the following parts:

Vendor Name	Vendor P/N	Description	QTY	UM	Honeywell P/N
Positronic Ind.	DD78F1OJVLC-15	P1 connector	1	EA	440-1158-009
Positronic Ind.	RD50F1OJVLC-15	P2 connector	1	EA	440-1233-001
Amphenol	79075	GPS Antenna connector	1	EA	440-1239-001
Honeywell	700-1710-001	Configuration Module	1	EA	700-1710-001
Bendix/King	071-04003-0002	Computer Mounting Tray	1	EA	405-0383-001

1.8.2 RS-232 Cable

The MK XXII EGPWS RS-232 Cable can be ordered using the following part numbers:

NOTE: The RS-232 Cable can be built by the Installer/Operator per the description in Section 4.4.2

Vendor Name	Vendor P/N	Description	QTY	UM	Honeywell P/N
Honeywell	704-2617-001	RS-232 Cable	1	EA	704-2617-001

1.8.3 Smart Cable

The MK XXII EGPWS Smart Cable can be ordered using the following part numbers:

Vendor Name	Vendor P/N	Description	QTY	UM	Honeywell P/N
Honeywell	951-0386-001	Smart Cable	1	EA	951-0386-001

Honeywell
MK XXII EGPWS Installation Manual

1.8.4 Terrain Database Cards

The MK XII EGPWS Terrain Database Cards can be ordered using the following part numbers:

Vendor Name	Vendor P/N	Description	QTY	UM	Honeywell P/N
Honeywell	424NAM	North America	1	EA	718-1447-xxx
Honeywell	424SAM	South America	1	EA	718-1448-xxx
Honeywell	424EUR	Europe	1	EA	718-1449-xxx
Honeywell	424EEU	Eastern Europe	1	EA	718-1450-xxx
Honeywell	424AFR	Africa	1	EA	718-1451-xxx
Honeywell	424PAC	Pacific	1	EA	718-1452-xxx
Honeywell	424ASI	Asia	1	EA	718-1453-xxx
Honeywell	424SPA	South Pacific	1	EA	718-1457-xxx
Honeywell	424MES	Middle East	1	EA	718-1458-xxx
Honeywell	402-6075-xxx	Label, TDB Front Panel	1	EA	402-6075-xxx

1.8.5 Flight History Card

The Flight History Card is a PCMCIA card that has been loaded with a down load instruction file to allow the down loading of flight history data from an EGPWS. Flight History files contain status information, fault history and flight data from 20 seconds prior to 10 seconds after a EGPWS caution or warning event. The card is used to aid in troubleshooting systems faults and or nuisance warnings.

The MK XXII EGPWS Flight History Card can be ordered using the following part numbers:

Vendor Name	Vendor P/N	Description	QTY	UM	Honeywell P/N
Honeywell	*	Flight History Download	1	EA	*

* For flight history download cards call Honeywell GPWS Hotline 1 800 813-2099

1.9 Accessories Required but not Supplied

1.9.1 ARINC 453 Terrain Display wiring

The Terrain display wiring (ARINC 453) must meet the display manufacturer's specifications including termination method. ARINC 453 buss wiring must meet the following requirements:

- Cable length must be less than 300 feet (91.4 meters).
- Wire to wire capacitance must not exceed 50 pF/foot.
- Shielded twisted pair with not less than one twist per inch.
- Impedance of 78 ohms \pm 10% at 1 MHz.

Vendor Name	Vendor P/N	Description	QTY	UM	Honeywell P/N
Pic Wire&Cable	D620224	ARINC 453 cable	A/R	EA	
Pic Wire&Cable	D5102QX	Hi Temp Quadaxial	A/R	EA	
Pic Wire&Cable	D771553	MIL-STD 1553 Data Bus	A/R	EA	
ECS	4122021	ARINC 453 cable	A/R	EA	

Honeywell
MK XXII EGPWS Installation Manual

Vendor Name	Vendor P/N	Description	QTY	UM	Honeywell P/N
Emteq	D 07002-100	ARINC 453 Cable	A/R	EA	
	M17/176-00002	Military Specification	A/R	EA	

1.9.2 GPS Antenna & cable

The GPS Antenna & cable can be ordered from their manufacturers using the following part numbers:

Vendor Name	Vendor P/N	Description	QTY	UM	Honeywell P/N
Bendix/King	071-01545-0200	KA 91 GPS Antenna	1	EA	
Bendix/King	071-01553-0200	KA 92 GPS Antenna	1	EA	300-1147-001
Comant	CI 405-2	KA 92 GPS Antenna	1	EA	300-1147-001
Bendix/King	050-03318-0000	Antenna Installation Kit	OPT	EA	405-0432-001
Sensor Systems	S67-1575-38	S67 GPS Antenna	1	EA	
Sensor Systems	S67-1575-52	S67 GPS Antenna	1	EA	
Sensor Systems	S67-1575-133	S67 GPS Antenna	1	EA	
Thermax	M17/128-RG400	Coax Cable, RG400	A/R	EA	
		Coax Cable, RG-142	A/R	EA	
Amp	225554-6	TNC Angle Plug, Male	1	EA	440-1239-001
Amphenol	79075	TNC Angle Plug, Male	1	EA	440-1239-001

1.9.3 Circuit Breaker

The Circuit Breaker needs to be a 3 Amp delayed action circuit breaker.

Vendor Name	Vendor P/N	Description	QTY	UM	Honeywell P/N
Klixon (T.I.)	7277-2-3	3 Amp Circuit Breaker, EGPWS power +28	1	EA	
Klixon (T.I.)	7277-2-1	1 Amp Circuit Breaker, lamp power +28	1	EA	

1.9.4 Annunciators & Switch/Annunciators

The devices shown below are switch/annunciators and are representative of those used in some installations. The installer/customer is cautioned to verify regulatory approval of the annunciation devices installed. See Appendix D for Vendors.

1.9.4.1 GPWS Warning (red) P/TEST; switch/annunciator assembly

The 'GPWS' annunciator provides visual indication of an EGPWS alert. The GPWS warning (red) annunciator also has a switch that is used to manually initiate EGPWS Self Test.

Honeywell
MK XXII EGPWS Installation Manual

1.9.4.2 GPWS Caution (amber) G/S CANCLD switch/annunciator assembly.

The 'GPWS caution annunciator provides visual indication of an EGPWS alert. The EGPWS caution (amber) annunciator also has a switch that is used to manually inhibit EGPWS Mode 5 glideslope alerts. The bottom half of the annunciator provides visual indication that the mode 5 glideslope alerts have been canceled.

1.9.4.3 LOW ALT / ON switch/annunciator assembly

The LOW ALT / ON switch/annunciator provides for manual selection of low altitude mode and visual indication that the Mk XXII EGPWS is in low altitude mode.

1.9.4.4 TERR INHIB / ON switch/annunciator assembly

The 'TERR INHIBIT' switch/annunciator provides for manual selection of terrain inhibit mode and visual indication that the EGPWS Terrain functions have been inhibited.

1.9.4.5 AUDIO INHIBIT / ON switch/annunciator assembly

The 'AUDIO INHIBIT' switch/annunciator provides for manual selection of audio inhibit mode and visual indication that the EGPWS mode 6 functions have been inhibited.

1.9.4.6 GPWS INOP / TERR INOP annunciator assemblies

The 'GPWS INOP' annunciator provides visual indication that the EGPWS GPWS modes have a disabled function.

The 'TERR INOP' annunciator provides visual indication that the EGPWS Terrain modes have a disabled function.

1.9.4.7 TERR DISPLAY / ON switch/annunciator assemblies

The 'TERR DISPLAY' switch/annunciator provides for manual selection of the terrain display and visual indication that the EGPWS Terrain Display has been selected for the associated display.

1.10 Cockpit Speaker (Optional)

The MK XXII EGPWS can interface to an 8 ohm audio speaker for cockpit annunciation of aural alerts.

Vendor Name	Vendor P/N	Description	QTY	UM	Honeywell P/N
Quam	30A05Z8	Audio Speaker	1	EA	
Utah	SP-3A	Audio Speaker	1	EA	
CTS	4AC3	Audio Speaker	1	EA	300-0218-002

Honeywell
MK XXII EGPWS Installation Manual

1.11 Tools Required

1.11.1 Crimping Tool - P1, P2, P3

Description	UM	QTY	Vendor Name & Part Number
Hand Crimping Tool	EA	1	Positronic Ind. 9507
Hand Crimping Tool	EA	1	Daniels AFM8
Hand Crimping Tool	EA	1	Military M22520/2-1

1.11.2 Contact Positioner - P1, P2, P3

Description	UM	QTY	Vendor Name & Part Number
Contact Positioner, Socket P1	EA	1	Positronic Ind. 9502-3
Contact Positioner, Socket P1	EA	1	Daniels K41 (for 22 to 28 AWG)
Contact Positioner, Socket P1	EA	1	Military M22520/2-06
Contact Positioner, Socket P2	EA	1	Positronic Ind. 9502-5
Contact Positioner, Socket P2	EA	1	Daniels K13-1 (20-24 AWG)
Contact Positioner, Socket P2	EA	1	Military M22520/2-08
Contact Positioner, Pin P3	EA	1	Positronics 9502-4
Contact Positioner, Pin P3	EA	1	Daniles K42 (22-28 AWG)
Contact Positioner, Pin P3	EA	1	Military M22520/2-09

1.11.3 Insertion/Removal Tool - P1, P2, P3

Description	UM	QTY	Vendor Name & Part Number
Removal Tool P1, P3	EA	1	Daniels DRK 95-22M
Removal Tool P1, P3	EA	1	Military M81969/8-02
Removal Tool P2	EA	1	Daniels DRK145
Insertion Tool P1, P3	EA	1	Daniels DAK 95-22M
Insertion Tool P1, P3	EA	1	Military M81969/8-01
Insertion Tool P2	EA	1	Daniels DAK145
Insertion/Removal Tool P1, P3	EA	1	Military M81969/1-04
Insertion/Removal Tool P2	EA	1	Military M81969/1-02

1.11.4 Spare Contacts - P1, P2, P3

Description	Mil Spec Part Number	
Contacts (P1) socket	M39029/57-354	22-28 GA Wire
Contacts (P2) socket	M39029/63-368	20-24 GA Wire
Contacts (P3) Pin	M39029/58-360	22-28 GA Wire

1.12 License Requirements

There are no Radio license requirements for the MK XXII EGPWS.

Honeywell
MK XXII EGPWS Installation Manual

SECTION II
INSTALLATION

Honeywell
MK XXII EGPWS Installation Manual

Honeywell
MK XXII EGPWS Installation Manual

SECTION II – INSTALLATION

SECTION II - INSTALLATION 33

2.1 INTRODUCTION 33

2.2 UNPACKING AND INSPECTING THE EQUIPMENT 33

2.3 EQUIPMENT INSTALLATION 33

 2.3.1 *General* 33

 2.3.2 *MK XXII Computer Location* 34

 2.3.3 *MK XXII Computer Installation* 34

 2.3.4 *Configuration Module Location* 35

 2.3.5 *Configuration Module Installation* 35

 2.3.6 *GPS Antenna location* 44

 2.3.7 *GPS Antenna Installation* 44

 2.3.8 *OAT Sensor Location* 44

 2.3.9 *OAT Sensor Installation* 44

 2.3.10 *Cockpit Annunciators / Switches* 44

 2.3.10.1 *Description* 45

 2.3.10.2 *Location* 46

 2.3.10.3 *Inhibit Switch Functions and Selection* 48

 2.3.10.3.1 *Terrain Inhibit* 48

 2.3.10.3.2 *Audio Inhibit (Timed)* 48

 2.3.10.3.3 *Audio Inhibit (Not Described Above)* 48

 2.3.10.3.4 *Low Altitude Mode* 48

SECTION II - INSTALLATION

2.1 Introduction

This section contains suggestions and factors to consider before installing the Enhanced Ground Proximity Warning System. Close adherence to these suggestions will assure satisfactory performance from the equipment.

NOTE

The conditions and tests performed on this article are minimum performance standards. It is the responsibility of those desiring to install this article either on or within a specific type or class of aircraft to determine that the aircraft installation conditions are within these performance standards. The article may be installed only if further evaluation by the applicant documents an acceptable installation and is approved by the Administrator.

2.2 Unpacking and Inspecting the Equipment

Exercise extreme caution when unpacking equipment. Perform a visual inspection of the unit for evidence of damage incurred during shipment. If a damage claim must be filed then save the shipping container and all packing materials to substantiate your claim. The claim should be filed as soon as possible. The shipping container and all packing materials should be retained in the event that storage or reshipment of the equipment is necessary.

2.3 Equipment Installation

2.3.1 General

The following paragraphs contain information pertaining to the installation of the MK XXII EGPWS, including instructions concerning the location and mounting of the equipment. The equipment should be installed in the aircraft in a manner consistent with acceptable workmanship and engineering practices, and in accordance with the instructions set forth in this publication. To ensure the system has been properly and safely installed in the aircraft, the installer should make a thorough visual inspection and conduct an overall operational check of the system, on the ground, prior to flight.

CAUTION

AFTER INSTALLATION OF THE CABLING AND BEFORE INSTALLATION OF THE EQUIPMENT, A CHECK SHOULD BE MADE WITH THE AIRCRAFT PRIMARY POWER SUPPLIED TO THE MOUNTING CONNECTOR, TO ENSURE THAT POWER IS APPLIED ONLY TO THE PINS SPECIFIED IN THE INTERWIRING DIAGRAMS IN SECTION III.

Honeywell
MK XXII EGPWS Installation Manual

2.3.2 MK XXII Computer Location

Care should be exercised to avoid mounting components near equipment operating with high pulse current or high power outputs such as radar and satellite communications equipment. In general, the equipment should be installed in a location convenient for operation, inspection, and maintenance, and in an area free from excessive vibration, heat, and noise generating sources.

The MK XXII EGPWS has an internal heater blanket therefore they can be mounted outside the heated area of the aircraft. The computers have been qualified for operation up to 50,000 feet and -55°C using the heater blanket.

All mechanical installation drawings, connector assembly diagrams, interwiring diagrams, and connector pin assignment tables referenced in this section are located at the end of Section II, of the manual. Determine the mounting location for the system components following the guidelines below.

The length of cables from the EGPWS connectors to other system units is not generally critical because unit interfaces are designed with high impedance inputs, low impedance outputs, and low noise susceptibility characteristics. The exception is the wires from the EGPWS Configuration Module, which was designed to be a part of the EGPWS connector backshell because of the requirement for short lead length.

To allow for inspection or repair of the wiring of the connector assembly itself, sufficient lead length should be left so that EGPWS may be moved several inches. A bend should be made in the harness to allow water droplets that might form on the harness due to condensation, to drip off at the bend and not collect in the connector.

Prior to installing any equipment, make a continuity check of all wires and cables associated with the system. Then apply power and check for proper voltages at system connectors, and then remove power before completing the installation.

2.3.3 MK XXII Computer Installation

The MK XXII EGPWS installation will conform to standards designated by the customer, installing agency, and existing conditions as to the unit location and type of installation. However, the following suggestions will assure a more satisfactory performance from the equipment.

- A. Plan a location on the aircraft so that the EGPWS is accessible for front panel maintenance controls. Check to be sure that there is adequate space in the front of the computer for connectors and cabling.
- B. Refer to Figure 2-2 and 2-3 for outline dimensions of the computer and mounting tray.
- C. Mount the EGPWS mounting tray in the aircraft radio rack or other location using the four screw mounting holes. Match drill the mounting holes using the Mounting Tray as a template.
- D. Ensure that the mounting tray is electrically bonded (less than 10 milli-ohm to aircraft ground).

Honeywell
MK XXII EGPWS Installation Manual

- E. Slide the EGPWS unit in the mounting tray, and secure it using the Hold Down latch.
- F. (After Continuity and Power check) Attach the cable harness to the front panel connectors and lock connectors using the slide lock of the P1 & P2 connectors. The EGPWS should be wired according to the interconnect diagrams in Section III, of this manual.

2.3.4 Configuration Module Location

The aircraft configuration is programmed into the EGPWS Configuration Module installed in the aircraft wiring. The Configuration Module is identified as Honeywell part number 700-1710-001. The Configuration Module is installed as one side of the P2 (50 pin) mating connector backshell and contains electrically reprogrammable memory for configuration storage. The Configuration Module when installed is wired directly to the appropriate pins in the P2 connector.

2.3.5 Configuration Module Installation

The purpose of this procedure is to give an assembly sequence for assembly of the Configuration Module with the P2 connector and backshell.

- A. The P2 connector, Honeywell part number 440-1233-001, vendor part number RD50F1OJVLC-15, when ordered comes with 50 contacts and a plastic backshell (hood).
- B. The Configuration Module will replace the Backshell Plate. The Backshell Plate can be discarded.
- C. Wire the Configuration Module to the P2 connector using contacts provided with the connector. Wire per the following wire list:

Wire Color	P2 pin #	Wire Color	P2 pin #
Violet	P2-17	Black	P2-50
Blue	P2-16	White	P2-49
Orange	P2-33	Red	P2-32

Honeywell
MK XXII EGPWS Installation Manual

- D. Position Slide Lock and Spring Clip onto connector.
- E. Install Backshell Housing onto connector. The Ground wire (used for ESD discharge) is terminated with shielded pigtailed inside the backshell to the P2 connector.
- F. Organize and dress wire exiting from the backshell, route Configuration Module wires in a coil. Install Cable Clamp, do not tighten Cable Clamp screws.
- G. Secure the Configuration Module to the connector using screws provided. Tighten Cable Clamp screws as required.

CONFIGURATION MODULE ASSEMBLY

REQUIRED: Two items as follows:

ITEM	1.0	Connector (P2)	Positronic Ind.	RD50F10JVLC-15 *
ITEM	2.0	Configuration Module	Honeywell	700-1710-001

* This item may be available from Honeywell under Part No. (440-1233-001)

ITEM 1 DESCRIPTION:

Connector P2 (Positronic Ind. PN RD50F10JVLC-15) is a packaged kit consisting of the following parts:

1.1	Connector, 50 socket D-Sub	Qty - 1
1.2	Contacts, size 20 crimp	Qty - 50
1.3	Backshell housing	Qty - 1
1.4	Backshell plate	Qty - 1
1.5	Screws, Phillips CSK	Qty - 2
1.6	Spring Clip	Qty - 1
1.7	Slide Lock	Qty - 1
1.8	Screws, Slotted	Qty - 2
1.9	Cable Clamp	Qty - 1

INSTALLATION ASSEMBLY SEQUENCE

STEP 1 Install all MK XXII system aircraft wiring to this connector using items 1.2 (Crimp Contacts) and item 1.1 (Connector). See figure 2-1.1 below.

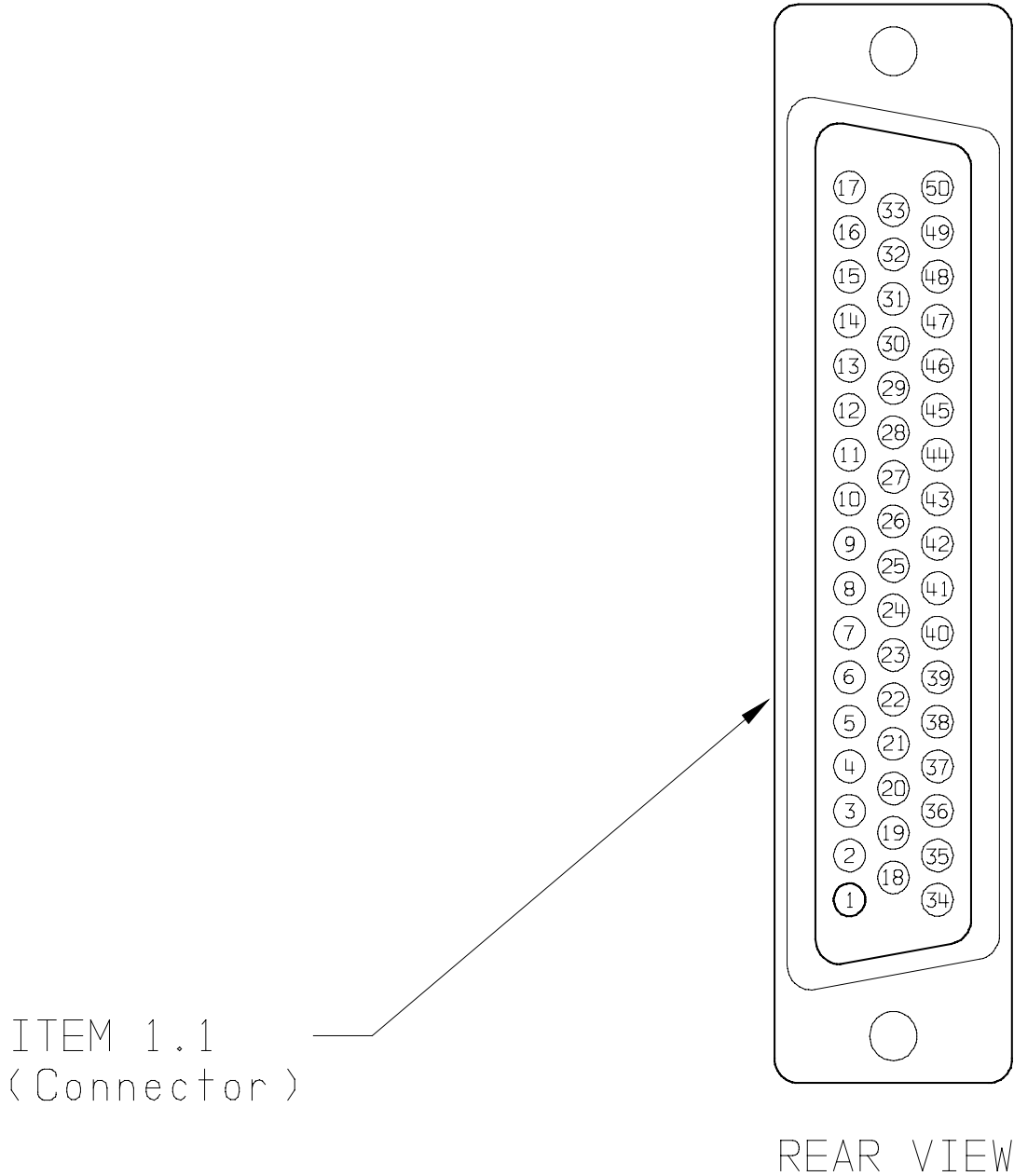

FIGURE 2-1.1 MK XXII EGPWS CONFIGURATION MODULE

Honeywell
MK XXII EGPWS Installation Manual

STEP 2

Wire item 2.0 (Configuration Module). This part will replace item 1.4 (Backshell plate). Install the pre-crimped colored wires into item 1.1 (Connector) as shown in figure 2-1.2 below.

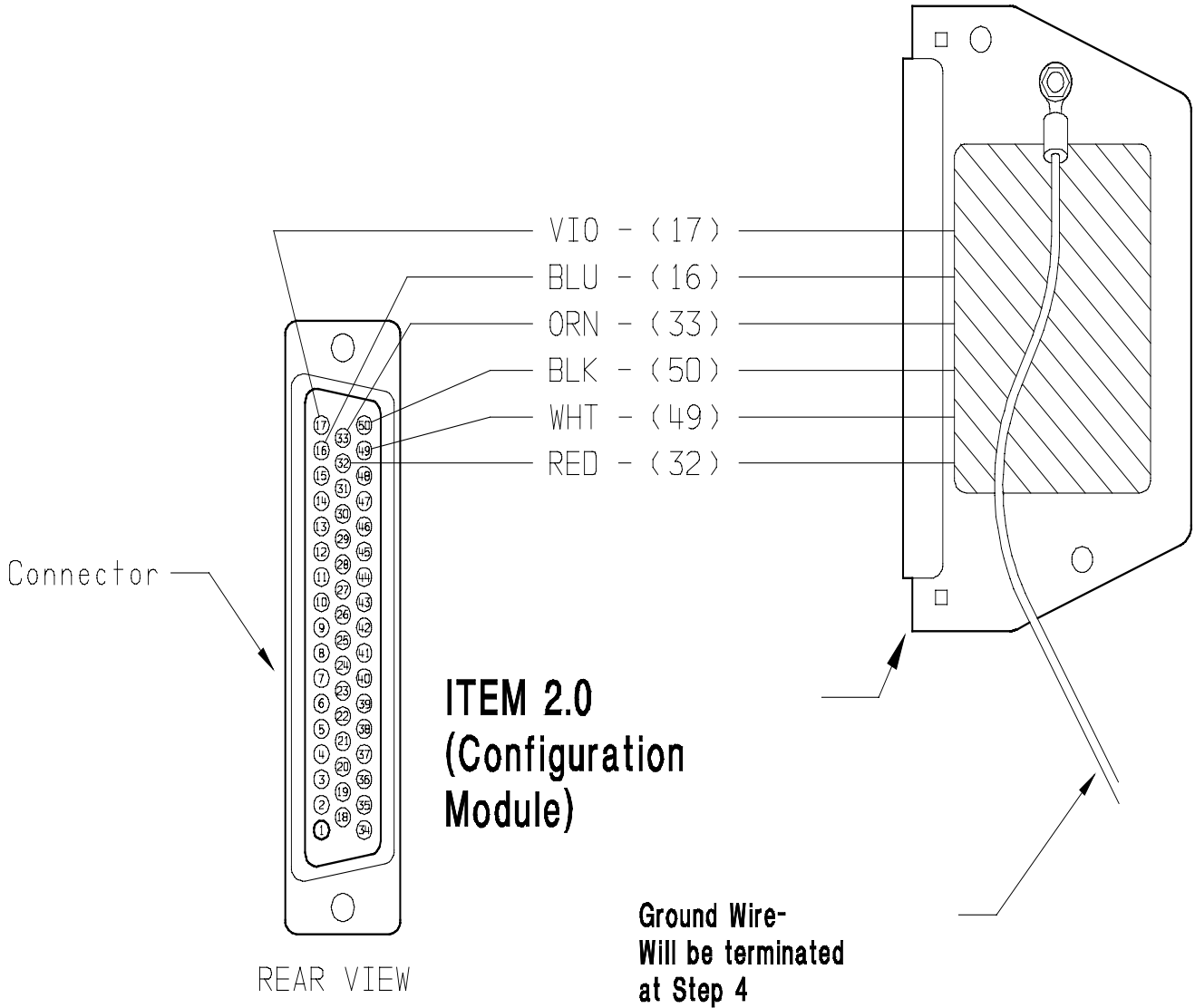

FIGURE 2-1.2 MK XXII EGPWS CONFIGURATION MODULE

Honeywell
MK XXII EGPWS Installation Manual

STEP 3 Position item 1.7 (Slide lock) onto wired connector as shown in figure 2-1.3 below:

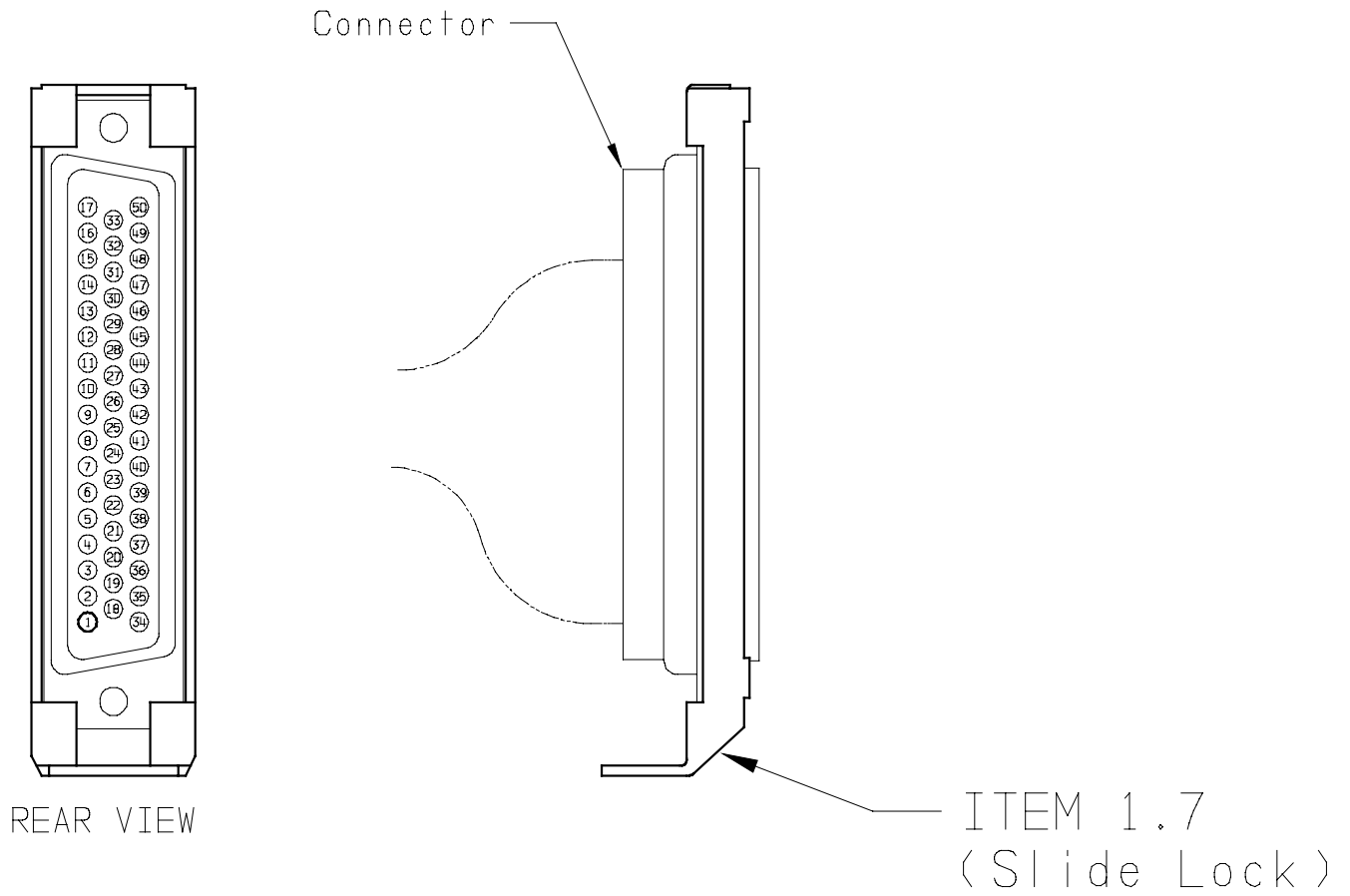

FIGURE 2-1.3 MK XXII EGPWS CONFIGURATION MODULE

Honeywell
MK XXII EGPWS Installation Manual

STEP 4 Install item 1.3 (Backshell Housing) onto connector using item 1.8 (Screws) as shown in figure 2-1.4 below:

Ground Wire (used for electrostatic discharge {ESD} protection) is terminated with shielded pigtails of wires at this connector.

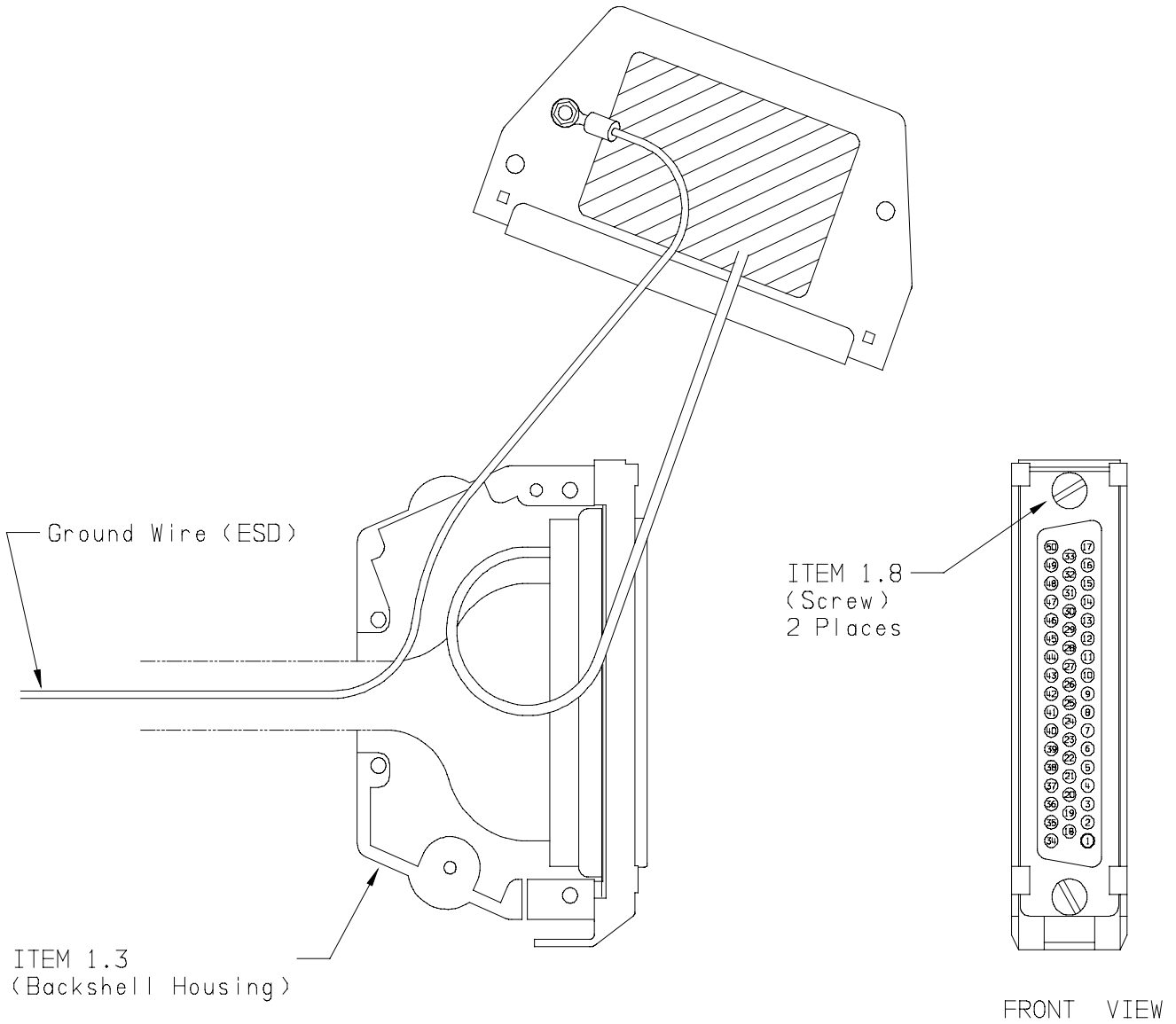

FIGURE 2-1.4 MK XXII EGPWS CONFIGURATION MODULE

Honeywell
MK XXII EGPWS Installation Manual

STEP 5 Install item 1.6 (Spring Clip) as shown figure 2-1.5 below:

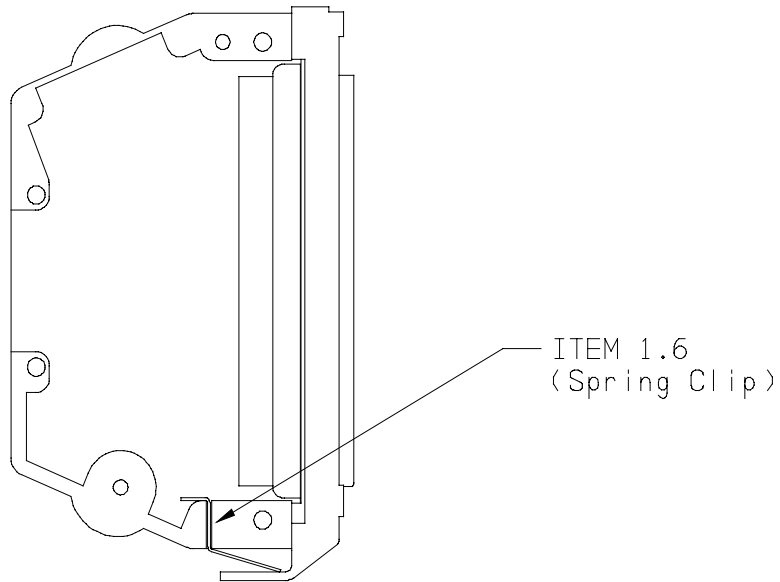

FIGURE 2-1.5 MK XXII EGPWS CONFIGURATION MODULE

Honeywell
MK XXII EGPWS Installation Manual

STEP 6 Organize and dress wiring exiting from backshell. Route Configuration Module wires exiting from connector, then coil as shown in figure 2-1.6 below. Install item 1.9 (Cable Clamp) as shown. Do not tighten screws yet.

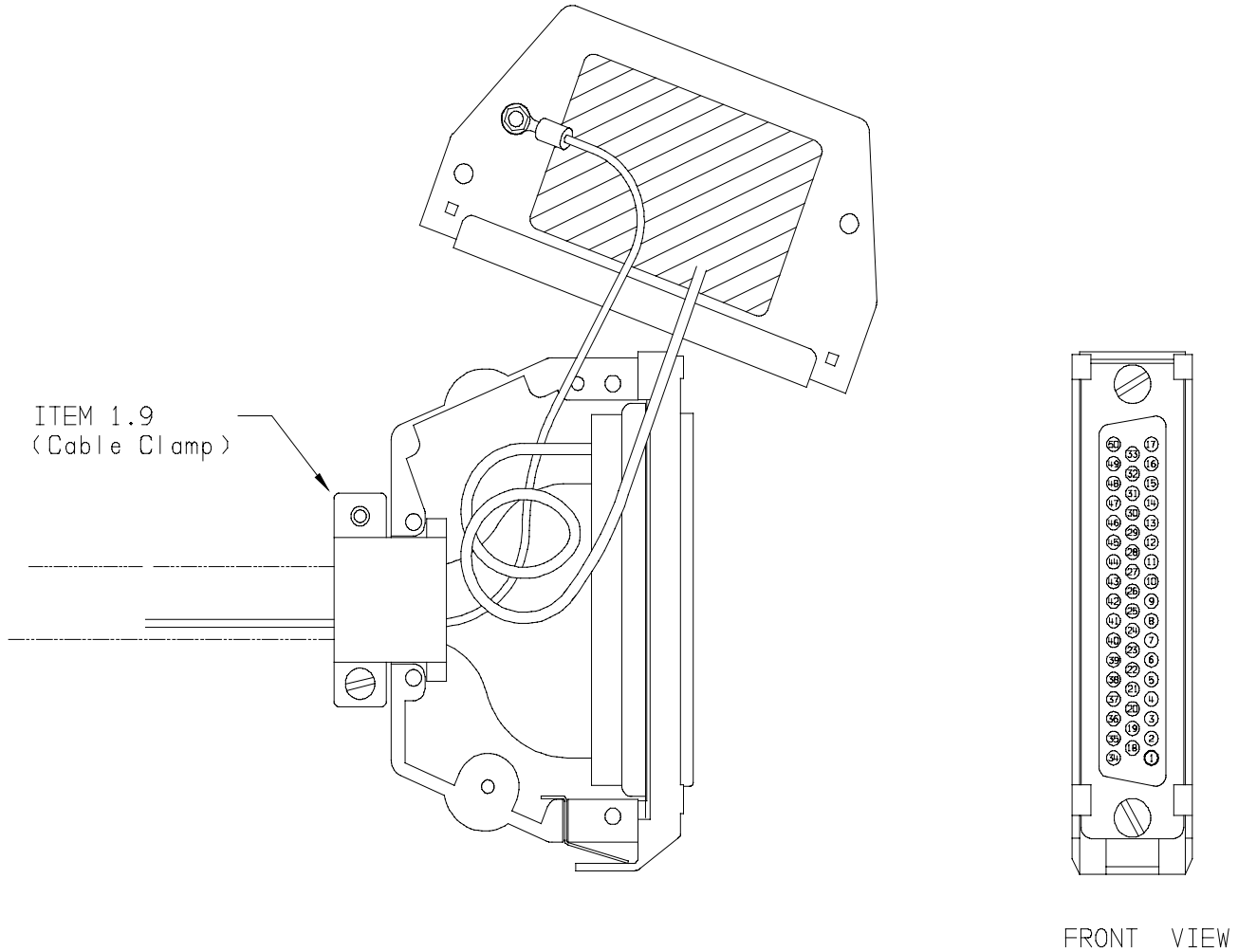

FIGURE 2-1.6 MK XXII EGPWS CONFIGURATION MODULE

Honeywell
MK XXII EGPWS Installation Manual

STEP 7 Secure Configuration Module to connector assembly using item 1.5 (Screws) as shown in figure 2-1.7 below. Tighten Cable Clamp screws as required.

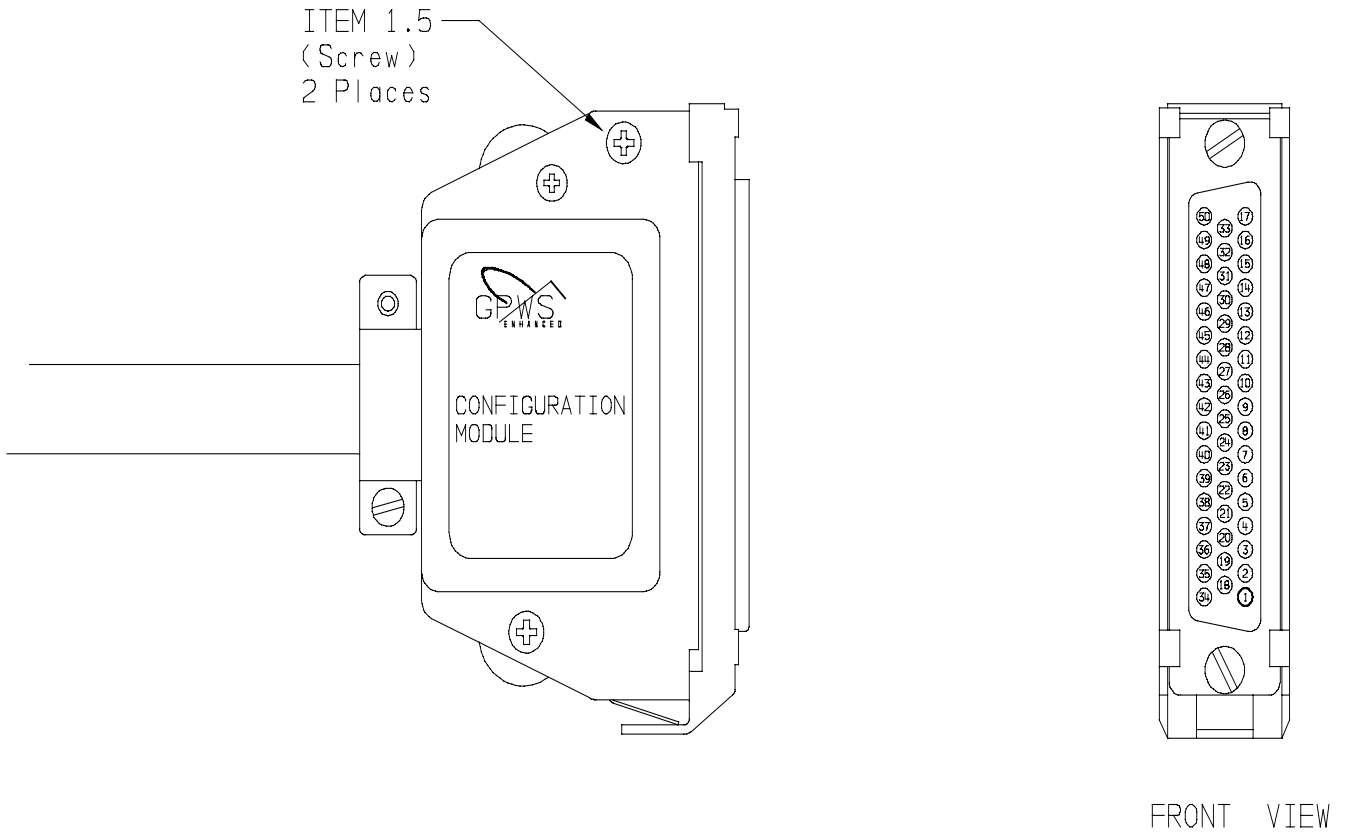

FIGURE 2-1.7 MK XXII EGPWS CONFIGURATION MODULE

2.3.6 GPS Antenna location

The antenna must be mounted on top of the fuselage. Avoid mounting the antenna near any projections such as the rotor mast, or engine exhaust, where shadows could occur or high heat could damage the antenna. It is recommended that there be a separation of at least 3 feet between the GPS antenna and any VHF Comm antenna on the aircraft. The antenna baseplate must be level within $\pm 5^\circ$ in both axis when the aircraft is level (level is defined as the aircraft attitude required when weighing the aircraft for weight and balance). If the antenna is tilted more than 5° or is mounted close to other objects that shadow it, loss of some of the satellites will occur and system performance may be degraded. See manufacturer's drawing in Appendix D for specifications of antenna, antenna cables, and connector information.

2.3.7 GPS Antenna Installation

Refer to manufacturer's procedures or applicable STC documentation.

2.3.8 OAT Sensor Location

The OAT sensor (CIC 05257) should be mounted on the underside (belly) of the aircraft or other convenient location meeting the following conditions. Avoid mounting the sensor where it can be affected by direct sunlight, or exhaust gases from engines or heaters. The probe tip should extend beyond the aircraft boundary layer into the turbulent airflow. See manufacturer's drawing in Appendix D for specifications.

2.3.9 OAT Sensor Installation

Refer to manufacturer's procedures or applicable STC documentation.

2.3.10 Cockpit Annunciators / Switches

This section provides information for selecting, locating and mounting of the MK XXII EGPWS Lighted annunciators / switches. **NOTE:** The nomenclature given for each lamp is an example only. Other manufacturers use nomenclature that is also acceptable. Refer to Honeywell Product Specification 965-1590-601 for additional information and for electrical loads specification

Honeywell
MK XXII EGPWS Installation Manual

2.3.10.1 Description

EGPWS warning **GPWS** **P/TEST**

This assembly is illuminated with Red background and black or white letters. For dark cockpits black background and Red letters. The EGPWS warning annunciator is not normally dimmable. For Lamp Format 1 (I/O Discrete Type 128) the lamp is activated during any Mode 1 through Mode 4, and Terrain /Obstacle Awareness alerts and warnings. For Lamp Format 2 (I/O Discrete Type 129) the lamp is activated during Mode 1 and Mode 2 Pull Up, and Terrain /Obstacle Awareness warnings. This assembly also includes a momentary switch that will activate EGPWS Self Test.

EGPWS caution **GPWS** **G/S CANCLD**

This assembly is illuminated with Amber background and black or white letters, for dark cockpits black background and Amber letters. The EGPWS alert annunciator is not normally dimmable. For Lamp Format 1 (I/O Discrete Type 128) the lamp is activated during any Mode 5 alert. For Lamp Format 2 (I/O Discrete Type 129) the lamp is activated during any Mode 1 through Mode 4, and Terrain /Obstacle Awareness alerts. This assembly also includes a momentary switch that will activate glideslope cancel.

LOW ALTITUDE **LOW ALT** **ON**

This assembly is illuminated with black background and white, green, or blue letters. This assembly also includes a momentary switch that will activate / de-activate (cancel) EGPWS low altitude mode.

TERRAIN INHIBIT **TERR INHIB** **ON**

This assembly is illuminated with black background and white, blue, or green letters. This assembly also includes a alternate action switch that will activate ./ de-activate (cancel) Terrain inhibit mode. **(Optional see section 2.3.10.3)**

AUDIO INHIBIT **AUDIO INHIB** **ON**

This assembly is illuminated with black background and white, blue, or green letters This assembly also includes a momentary switch that will activate ./ de-activate (cancel) Audio inhibit mode. **(Optional see section 2.3.10.3)**

GPWS system validity **GPWS INOP** **TERR INOP**

This assembly is illuminated with black background and amber letters activated during any detected partial or total failure of the GPWS modes 1-5. And TA&D

TERRAIN select **TERR DISPLAY** **ON**

This assembly is illuminated with white background and activated after the flight crew has initiated the manual selection of the EGPWS terrain display for the associated cockpit display. This assembly also includes a momentary switch that will activate EGPWS Terrain display feature.

2.3.10.2 Location

Cockpit layout, size and operator's preference will determine if only one set of lights is used (i.e., mounted in the center), or if dual sets of lights are used (one set on each side), or a combination thereof is desired. For a typical example of cockpit light locations refer to Figure 2-7. For panel cutouts and assembly options see the manufacturer's specifications in Appendix D. The following are recommended locations:

GPWS warning (red) & GPWS alert (amber)

These lights should be located together and in the flight crew's "primary field of view". This would include either the instrument panel or the edge of the glareshield.

LOW ALTITUDE

This light should be located in the flight crew's "field of view" and within reach of both crewmembers. This light/switch may be located in an assembly with the GPWS red and GPWS amber lights and/or other EGPWS annunciators.

TERR INHIBIT ON (Optional see section 2.3.10.3)

This light should be located in the flight crew's "field of view" and within reach of both crewmembers. This light/switch may be located in an assembly with the TERR DISPLAY light(s) and/or other EGPWS annunciators.

AUDIO INHIBIT ON (Optional see section 2.3.10.3)

This light should be located in the flight crew's "field of view" and within reach of both crewmembers. This light/switch may be located in an assembly with the TERR DISPLAY light(s) and/or other EGPWS annunciators.

TERR DISPLAY ON

This light should be located near the associated cockpit display, in the flight crew's "field of view" and within reach of one or both crewmembers. This light/switch may be located in an assembly with the TERR INHIBIT light(s) and/or other EGPWS annunciators.

GPWS INOP

This light should be located within crewmember's "field of view" or with other system INOP lights of similar importance. It is recommended that this light not be located in the flight crew's "primary field of view". The reason being that in the event of a GPWS system failure at the beginning of a flight, this light will remain "ON" until the problem is fixed.

TERR INOP

This light should be located within at least one crewmember's "field of view" or with other system INOP lights of similar importance. Note: Annunciators are available with split legend GPWS INOP / TERR INOP in one assembly. It is recommended that this light not be located in the flight crew's "primary field of view". The reason being that in the event of a GPWS system failure at the beginning of a flight, this light will remain "ON" until the problem is fixed.

**Honeywell
MK XXII EGPWS Installation Manual**

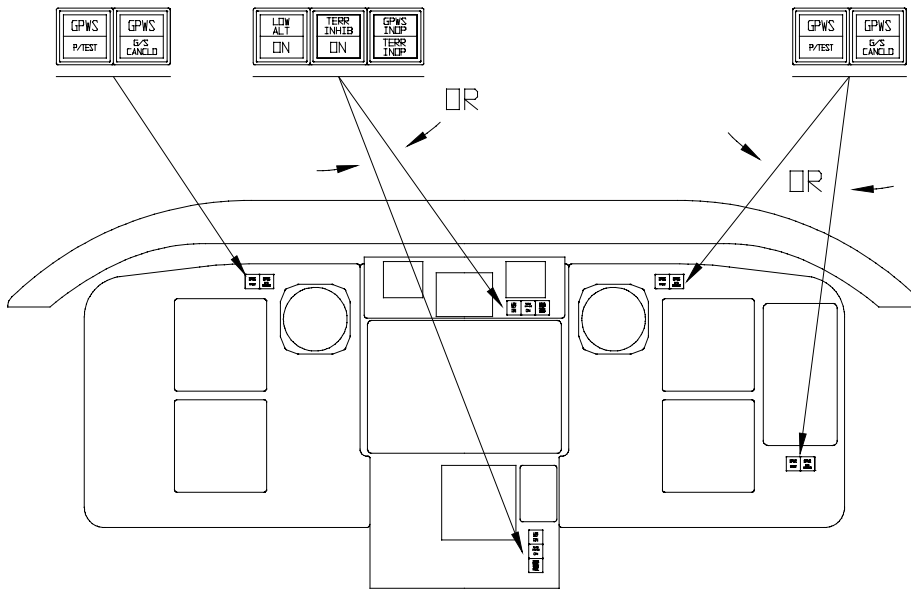

SUGGESTED LIGHT LOCATIONS for SMALL COCKPITS

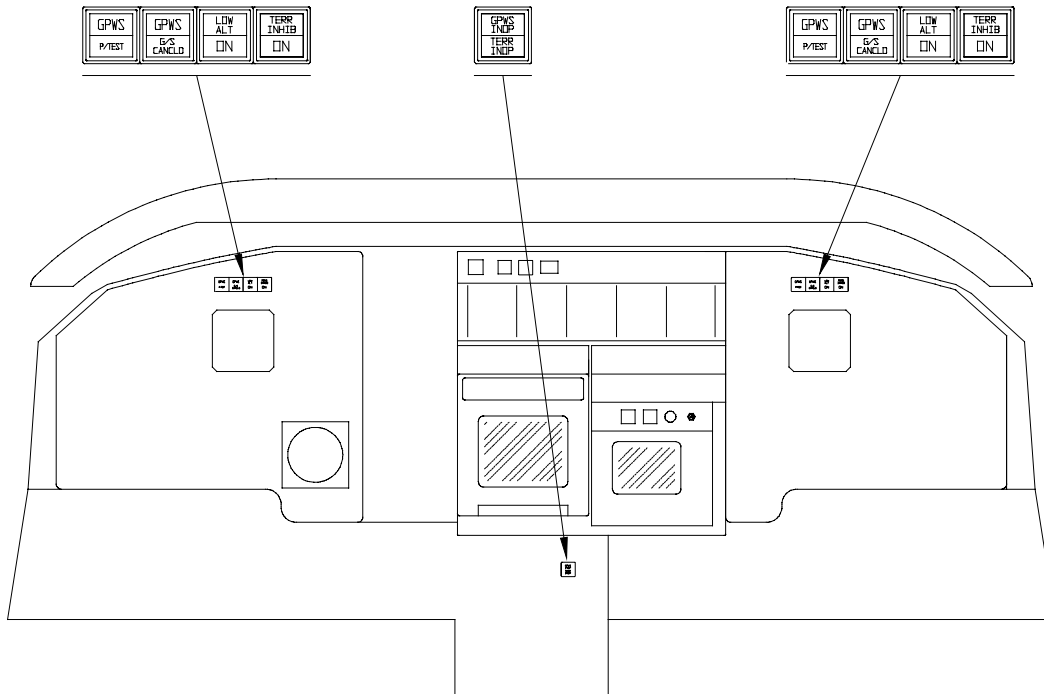

SUGGESTED LIGHT LOCATIONS for WIDE COCKPITS

FIGURE 2-1.8 MK XXII EGPWS Annunciators/Switches Location

2.3.10.3 Inhibit Switch Functions and Selection

The Terrain Inhibit and Audio Inhibit functions are optional but it is recommended that one be used to inhibit the system during certain operations. The operator should evaluate the two options together with the Low Altitude Mode function and select the one that best fits his operational requirements. The Low Altitude Mode is also described below for reference.

2.3.10.3.1 Terrain Inhibit

The Terrain Inhibit will inhibit Terrain and Obstacle audio alerts and warnings. It will not deselect the Terrain Display. The switch is a toggle action, which must be pressed to turn ON and re-pressed to turn OFF. The switch lighting must be activated thru the switch contacts. This Inhibit is recommended for corporate transport operations.

2.3.10.3.2 Audio Inhibit (Timed)

The Timed Audio Inhibit will inhibit all audio output for a period of 5 minutes. It will not affect visual alert and warning outputs and will not deselect the terrain display. The switch is momentary and the lamp is illuminated by an output from the EGPWS. This inhibit is recommended for EMS and SAR operations.

2.3.10.3.3 Audio Inhibit (Not Described Above)

The Audio Inhibit will inhibit all audio output as long as it is active. It will not affect visual alert and warning outputs and will not deselect the terrain display. The switch is a toggle action, which must be pressed to turn ON and re-pressed to turn OFF. The switch lighting must be activated thru the switch contacts. This Inhibit is NOT RECOMMENDED.

2.3.10.3.4 Low Altitude Mode

To allow for helicopter operations that require low altitude flight a Low Altitude function is enabled with a switch. This function is designed for flight at low altitude in VFR conditions. When this function is engaged Mode 2 and Mode 4 warning boundaries are significantly reduced and Terrain Advisory look ahead distances are reduced. . Low Altitude operation is defined as operation below 500 feet AGL. There are other circumstances where the use of the Low Altitude Mode is appropriate. Those include operation in a high-density metropolitan environment with high rise buildings, operation below 1250 feet AGL when the GPS is not operational or is providing poor accuracy.

Honeywell
MK XXII EGPWS Installation Manual

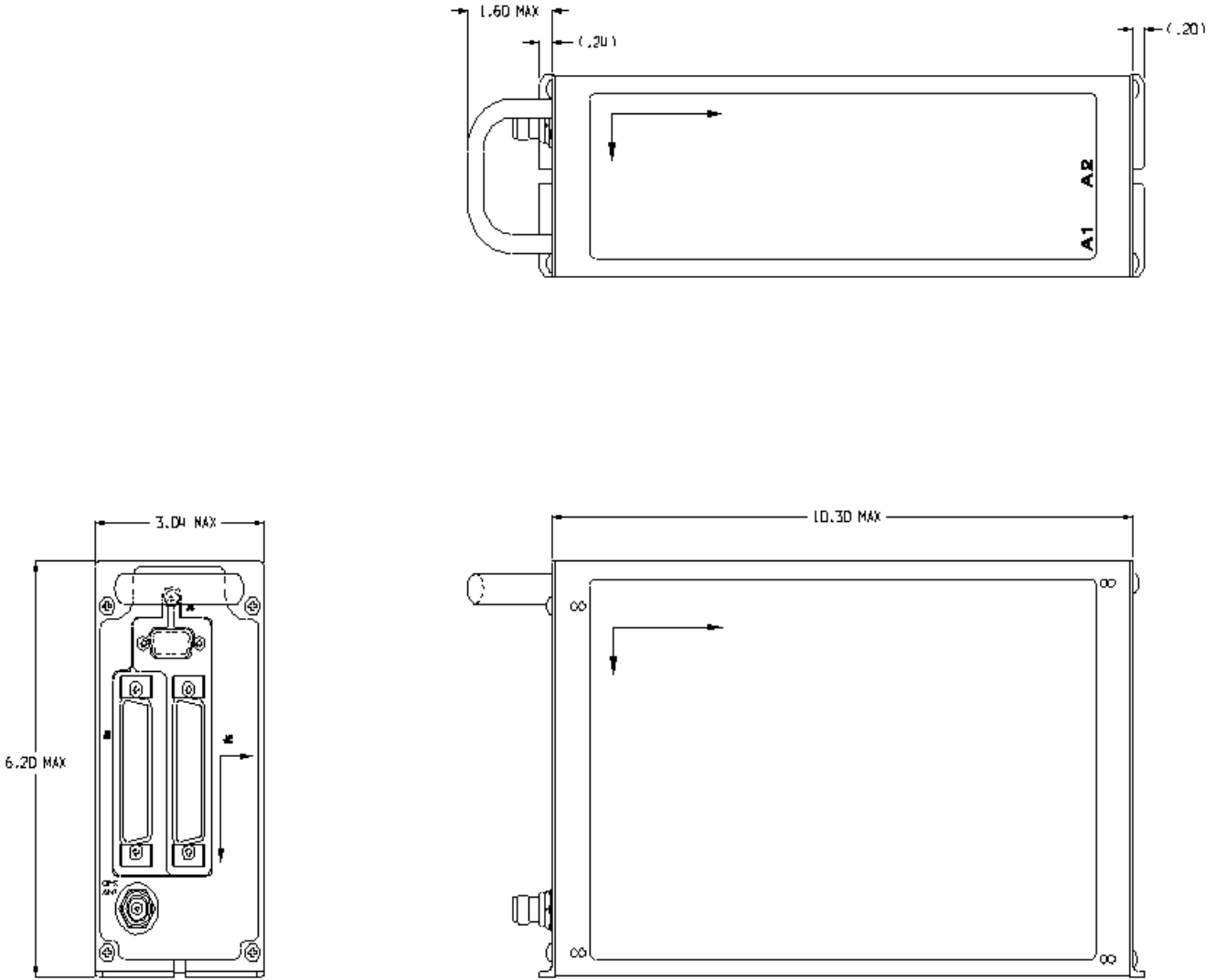

FIGURE 2-2 MK XXII EGPWS OUTLINE

Honeywell
MK XXII EGPWS Installation Manual

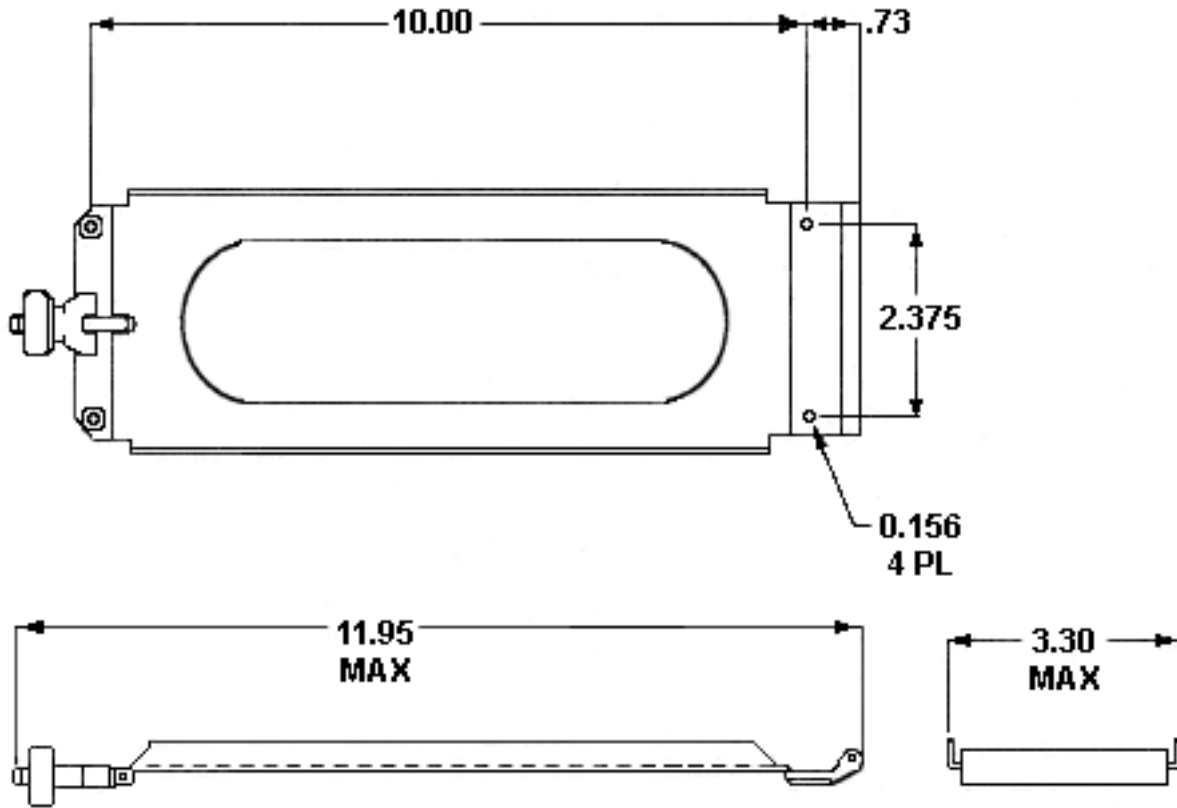

FIGURE 2-3 MK XXII EGPWS MOUNTING TRAY

Honeywell P/N

405-0383-001

Honeywell
MK XXII EGPWS Installation Manual

SECTION III
SYSTEM PLANNING

Honeywell
MK XXII EGPWS Installation Manual

SECTION III – SYSTEM PLANNING

SECTION III – SYSTEM PLANNING.....	57
3.1 INTRODUCTION	57
3.2 SYSTEM WIRING/ ELECTRICAL INTERFACES.....	57
3.2.1 Primary Power Input	57
3.2.2 Chassis Ground	57
3.2.3 GPS Antenna.....	58
3.2.4 Analog and Digital Inputs.....	58
3.2.5 Discrete Inputs.....	58
3.2.6 Serial Outputs.....	58
3.2.7 Audio Output.....	59
3.2.8 Discrete Outputs.....	59
3.2.9 Configuration Module	59
3.3 CONFIGURABLE INTERFACES.....	60
3.3.1 Category 1 - Aircraft / Mode Type Select	60
3.3.1.1 Aircraft / Mode Type.....	60
3.3.1.2 Instructions	60
3.3.1.3 Generic Helicopter with and without Torque.....	60
3.3.2 Category 2 – Air Data Input Select.....	61
3.3.2.1 Instructions	61
3.3.2.2 Examples	62
3.3.2.3 Analog altitude and 500 ohm OAT	62
3.3.2.4 Digital – ARINC 429 (Cat. 2 ID 5, 1, 6)	63
3.3.2.5 Digital –ARINC 575 (Cat. 2 ID 2)	64
3.3.2.6 Shadin 2000 (Cat. 2 ID 10)	65
3.3.2.7 Digital – ARINC 429 Dual IOC Buses (Cat. 2. ID 255)	66
3.3.3 Category 3 – Position Input Select	67
3.3.3.1 Instructions	67
3.3.3.2 ARINC 743 Format	67
3.3.3.Examples	68
3.3.3.1 ARINC 429 BUS (Cat. 3 ID 0,1,4,5).....	68
3.3.3.2 RS-232 Transmit-Receive, 9600 baud (Cat. 3 ID 3)	68
3.3.3.3 Dual ARINC 429 BUS (Cat. 3 ID 255).....	69
3.3.4 Category 4 – Altitude Callouts	70
3.3.4.1 Instructions	70
3.3.5 Category 5 – Audio Menu Select	71
3.3.5.1 Instructions	71
3.3.6 Category 6 – Terrain Display Select	72
3.3.6.1 Instructions	72
3.3.6.2 TAD Selection	72

Honeywell
MK XXII EGPWS Installation Manual

3.3.6.3 Terrain Display Configuration Group.....	73
3.3.6.4 Display Input Control Group.....	75
3.3.6.5 Output 429 Bus Group.....	75
3.3.6.6 Example.....	75
<i>3.3.7 Category 7 – Options Select Group #1.....</i>	<i>81</i>
3.3.7.1 Instructions.....	81
3.3.7.2 Steep Approach (Not Available in the Mk XXII).....	81
3.3.7.3 TA&D Alternate Pop-up.....	81
3.3.7.4 Peaks Mode.....	82
3.3.7.5 Obstacle Awareness.....	82
3.3.7.6 Bank Angle Callout Enabling.....	82
3.3.7.8 WOW Reversal.....	83
3.3.7.9 GPS Altitude Reference.....	83
<i>3.3.8 Category 8 – Radio Altitude Input Select.....</i>	<i>84</i>
3.3.8.1 Instructions.....	84
3.3.8.2 Example.....	84
3.3.8.3 Digital Radio Altitude Interface.....	84
3.3.8.4 Analog Radio Altitude Interface.....	85
<i>3.3.9 Category 9 – Navigation Inputs Select.....</i>	<i>86</i>
3.3.9.1 Instructions.....	86
3.3.9.2 Example.....	87
3.3.9.3 Analog Glideslope Interface (cat. 9 ID 0,1,5).....	87
3.3.9.4 Digital Glideslope/Localizer Interface.....	88
3.3.9.5 Dual Glideslope Receiver.....	88
<i>3.3.10 Category 10 – Attitude Input Select.....</i>	<i>89</i>
3.3.10.1 Attitude Signals.....	89
3.3.10.2 Instructions.....	89
3.3.10.3 Example.....	90
3.3.10.4 Analog Roll Angle (Synchro).....	90
3.3.10.5 Digital ARINC 429 High Speed.....	91
<i>3.3.11 Category 11 – Heading Input Select.....</i>	<i>92</i>
3.3.11.1 Instructions.....	92
3.3.11.2 Magnetic Heading.....	92
3.3.11.3 Example.....	93
3.3.11.3.1 Analog Heading (Synchro) (CAT. 11 ID 0).....	93
3.3.11.3.2 Digital ARINC 429 High Speed.....	94
<i>3.3.12 Category 12 – Windshear Input Select.....</i>	<i>95</i>
3.3.12.1 Instruction.....	95
<i>3.3.13 Category 13 – Input / Output Discrete Type Select.....</i>	<i>96</i>
3.3.13.1 Instruction.....	96
3.3.13.2 Input/Output Discretes.....	96
3.3.13.3 Audio Inhibit Discrete.....	97
3.3.13.4 Landing Gear Discrete.....	97

Honeywell
MK XXII EGPWS Installation Manual

3.3.13.5 Weight ON Wheels (WOW) Discrete	97
3.3.13.6 Glideslope Cancel Discrete	98
3.3.13.7 Mode 6 Low Volume Discrete	98
3.3.13.8 Autopilot Engaged Discrete	98
3.3.13.9 Terrain Awareness Inhibit	99
3.3.13.10 Self Test Discrete	99
3.3.13.11 Glideslope Inhibit Discrete.....	99
3.3.13.12 Timed Audio Inhibit Discrete.....	100
3.3.13.13 Low Altitude Mode Select Discrete	100
3.3.13.14 Output Discretes.....	100
3.3.13.15 Lamp Format	100
3.3.13.16 GPWS INOP Discrete	101
3.3.13.17 TAD INOP Discrete	101
3.3.13.18 GPWS Warning Discrete.....	101
3.3.13.19 GPWS Alert Discrete	101
3.3.13.20 Glideslope Cancel Discrete	101
3.3.13.21 TCAS Inhibit Discrete.....	101
3.3.13.22 Terrain Display Select #1 & #2 Discrete.....	102
3.3.13.23 Timed Audio Inhibit Discrete.....	102
3.3.13.24 Low Altitude Mode Discrete	102
<i>3.3.14 Category 14 – Audio Output Level</i>	<i>104</i>
3.3.14.1 Instructions	104
<i>3.3.15 Category 15, Autorotation Threshold.....</i>	<i>105</i>
3.3.15.1 Instruction.....	105

SECTION III – SYSTEM PLANNING

3.1 Introduction

This section provides information for selecting features and wiring the electrical interfaces of the MK XXII EGPWS. Sample wiring diagrams for the most commonly used MK XXII EGPWS configurations are provided in Appendix B. Appendix E Section E 3 groups features (functions) into sets called Categories. This document follows the Category structure of the Appendix E . It provides descriptions of the features and instructions for selecting features and for determining the correct wiring.

1. Make a copy of Appendix E Table E 3. Use this table along with Appendix A Fig A-1.1, A1.2, and A1.3 to record feature selection and determine the wiring interface.

3.2 System Wiring/ Electrical Interfaces

System wiring is broken down into the following main components:

- Electrical Interfaces (power and ground)
- GPS Antenna
- Analog and Digital Inputs
- Discrete Inputs
- Serial Outputs
- Audio Outputs
- Discrete Outputs
- Configuration Module

Many of these inputs and outputs will be defined as the Categories are selected for Configuration Module programming. Appendix E Table E 4 shows the typical usage for each pin, on the Left (J1), Right (J2) and Upper (J3) connectors.

3.2.1 Primary Power Input

The MK XXII EGPWC requires a primary power input (28 VDC input power) and ground. The Primary power should be connected as follows.

Pin	Signal
J1-40, J1-60	+28 VDC Input
J1-41, J1-61	+28 VDC Return

Recommended EGPWC Power Control Device: 3 Amp Delayed Action Circuit Breaker

3.2.2 Chassis Ground

Chassis ground provides a redundant metal connection and should not be used as a normal current carrying conductor. Chassis ground should be connected as follows:

Pin	Signal
J1-42, J1-53	GND

3.2.3 GPS Antenna

A GPS antenna connector is available on the front of the MK XXII EGPWS 965-1590-0XX.

3.2.4 Analog and Digital Inputs

The analog and digital inputs to the MK XXII EGPWS are defined as the Categories are selected. Instructions for documenting these interfaces are provided with the Category selection instructions. Section 3.3 contains detailed category configuration information.

3.2.5 Discrete Inputs

Additional information for some discretes is provided within the Category in which they are used. See section 3.3.13.

3.2.6 Serial Outputs

The EGPWC provides for ARINC 453 and ARINC 429 serial outputs.

Terrain display data is output on two ARINC 453 channels when the Terrain Awareness display function is enabled.

Two ARINC 429 low speed output buses provided by the EGPWC. The ARINC 429 output data includes:

1. Internal data (data output for test purposes only such as internal logic booleans, Geometric Altitude, and Terrain Clearance information).
2. Alert/Warning status (Voice and Lamp activity can be provided to display systems and flight recorders).
3. Internal mode status.
4. Terrain display messages for TAD cockpit integration.

Note: During EGPWS Self Test, the SSM of each output label is set to the Functional Test status code.

For category configuration information see section 3.3.6.

3.2.7 Audio Output

The audio outputs consist of both an 8-ohm amplifier and a transformer isolated 600-ohm output. Audio output messages are provided as specified in the selected Audio Menu (Category 5) when inputs are valid and the audio inhibit discretes are not active.

When audio inhibit is enabled, the output discrete(s) associated with suppressed message(s) are active.

3.2.8 Discrete Outputs

The MK XXII EGPWS provides for up to twelve 0.5 amp (1 amp maximum) Ground/Open discrete outputs. The discrete outputs are defined in Appendix E *Category 13*.

The discrete outputs are optional if the ARINC 429 output data is used for driving the alert/warning lamps via a symbol generator. Except for fully integrated cockpits, most Aircraft Types do not use the ARINC 429 output data for lamp control. (This data is typically sent to the Flight Data Recorder.)

All outputs to lamps are driven by solid state switches to ground. These outputs can also be used as discrete drivers for other devices (e.g. terrain display switching). See section 3.3.13.

3.2.9 Configuration Module

The EGPWS aircraft configuration is programmed into a configuration module installed in the aircraft wiring. This Configuration Module is identified as Honeywell part number 700-1710-001. The configuration module is installed as part of the P2 mating connector backshell and contains electrically reprogrammable memory for configuration storage. By this method the aircraft configuration is stored in the configuration module on the aircraft and each newly installed EGPWS computer does not require operator assisted programming before or during installation. The aircraft configuration in the Configuration Module can be changed at any time by use of the WinViews software, as explained in Section 4.

3.3 Configurable Interfaces

The following subsections define configurable interfaces for the EGPWS. Typical interface connection information and diagrams are provided. Use this in conjunction with Appendix E which has detailed interface configuration information.

3.3.1 Category 1 - Aircraft / Mode Type Select

Category 1 specifies the general aircraft type, warning mode definitions, , fixed or retractable gear, and engine torque interface.

Note: Category 15 will set the engine torque value used for autorotation mode.

3.3.1.1 Aircraft / Mode Type

The Aircraft Type identifies the aircraft as "Manufacture and Model". The aircraft category defines configurable data that control performance. The configurable values are not user defined or controlled.

Appendix E Table E 3.1.1 lists the combinations of Aircraft/Mode Types and identifies the first MK XXII EGPWS version in which the option was available (see the Effectivity entry), and describes the options available with each Aircraft/Model type (see Description column).

3.3.1.2 Instructions

1. Using Appendix E Tables E 3, under Step/category 1 select Aircraft type. Using Table E 3.1.1 select ID number for your aircraft type and record that number on Table E 3 under Ident No. This number will be used for programming the configuration module.
2. Using Appendix E Table E 3.1.1 under **Aircraft/Model Type Table** use table E 3.1.1-x to determine the torque wiring interconnects and record it on Appendix A Fig A1-2.

Note. Aircraft types 129, 130 and 138 with software version –010 and earlier are configured for the raw low level DC torque input. This interface will not work. With software version –011 these types are configured to use an external Buffer Amplifier provideing a gain of 30.23. For these applications it is recommended that either the No Torque configuration or the Shadin Converter configuration, described below, be used.

3.3.1.3 Generic Helicopter with and without Torque

For any airframe not listed in Appendix E table E 3.1.1 contact Honeywell GPWS hot line 1 800 813-2099.

Generic helicopter types are provided for aircraft with torque interfacing problems. Category 1 ID type 146, 147, 148, and 149, allow interface to airframes without torque input,. These types do

Honeywell
MK XXII EGPWS Installation Manual

not detect autorotation and thus do not provide the autorotation altitude callouts or advanced gear warnings. Mode 1 is inhibited in these types. The generic types are segregated into retractable and fixed gear configurations and tail strike warning profiles. Contact the **Honeywell GPWS hot line 1 800 813-2099** for help in selecting the correct generic type.

Category 1 ID types 150, 151, 152 and 153 are provided for applications where low level DC torque signals are externally amplified and scaled to a common 0.040 VDC per %.

Category 1 ID types 154, 155, 156 and 157 are provided for applications where low level DC torque is scaled and converted to ARINC 429 using the Shadin DC Torque to 429 Converter, Part Number 933755-00. This is particularly applicable to S-76-A/A+/A++ /C, and Bell 407 aircraft.

Contact the **Honeywell GPWS hot line 1 800 813-2099** for help in selecting the correct generic type.

3.3.2 Category 2 – Air Data Input Select

Category 2 defines the Air Data interface. The Air Data input currently defines 5 analog and 6 digital air data types.

3.3.2.1 Instructions

1. Using Appendix E Table E 3, under Step/category 2 select Air Data Source. Using table E 3.1.2 and 3.1.2-x select the ID number for your air data source and record that number on Table E 3 under Ident No. for step 2. This number will be used during programming of the configuration module.
2. Using Appendix E Tables E 3.1.2-x, where x is the Air Data Type number, define the electrical interfaces required to support your Air Data Type. Using Table E 3.1.2-x determine the wiring interconnects and record it on Appendix A Fig A1-2.

Honeywell
MK XXII EGPWS Installation Manual

3.3.2.2 Examples

3.3.2.3 Analog altitude and 500 ohm OAT

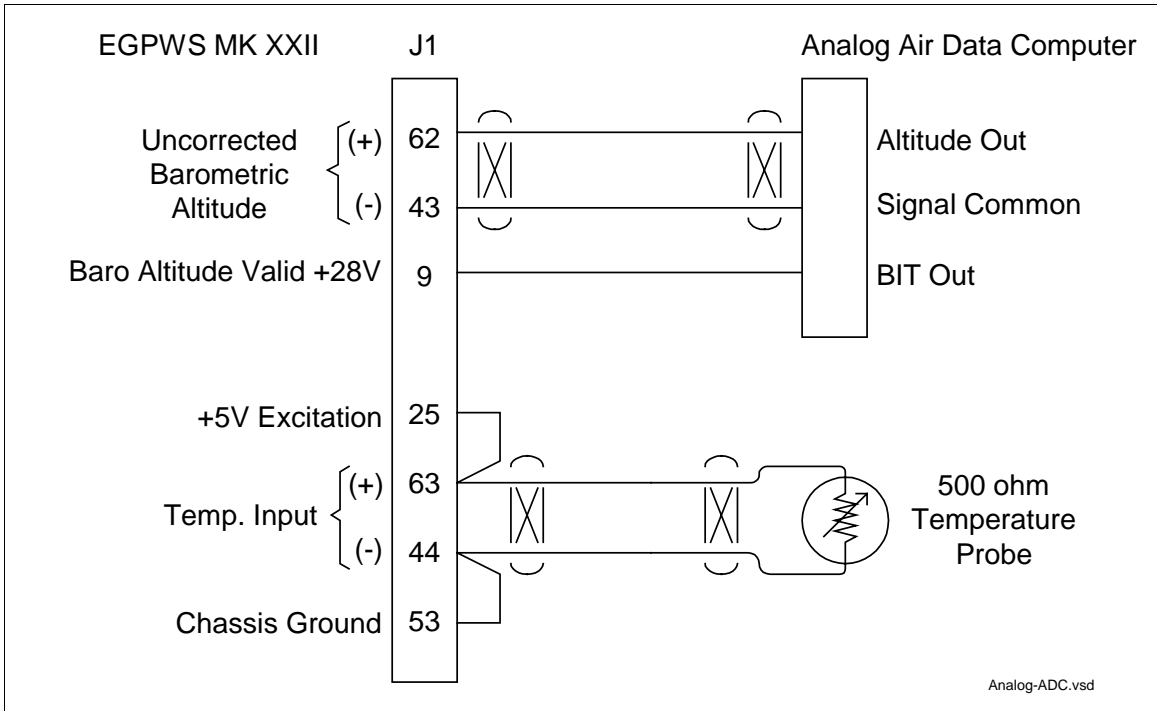

Vendor Model	Cat 2	Uncorrected Baro Altitude		
	ID	Altitude Out	Common	BIT Out
CIC 04077	0	J1-F	J1-G	J1-E
Collins ADS-65	3	J1-12	J1-13	J1-5
CIC 02702	4	J1-A	J1-B	J1-E
Honeywell AZ-241	11/12	J1-63	J1-11	J1-12
Honeywell AZ-242	11/12	J1A-40	J1A-11	J1A-12
Honeywell AZ-648	11/12	J1-J	J1-G	J1-U
Honeywell AZ-800	11/12	J1A-78	J1A-10	J1A-34
Honeywell AZ-810	11/12	J1A-78	J1A-10	J1A-34

NOTE: The connector pin numbers given in the Table above are to the best knowledge of Honeywell EGPWS engineering. Please contact the manufacturer's customer service to confirm your installation.

NOTE: Honeywell AZ-810 should only be used as an analog source if it does not have a digital interface.

NOTE: The CIC 02702 scaling was changed in -008 software. The analog barometric altitude conversion to barometric altitude rate noise problem was fixed in -008 software.

Honeywell
MK XXII EGPWS Installation Manual

3.3.2.4 Digital – ARINC 429 (Cat. 2 ID 5, 1, 6)

Air Data Type 1 (AZ-800 or equivalent) is a low speed, digital ARINC 429 signal having the air data labels 203, 206, 212, and 213.

Air Data Type 5 (AZ-800 or equivalent) is a low speed, digital ARINC 429 signal having the air data labels 203, 204, 206, 212, and 213.

Air Data Type 6 (AZ-800 or equivalent) is a low speed, digital ARINC 429 signal having the air data labels 203, 206, and 213.

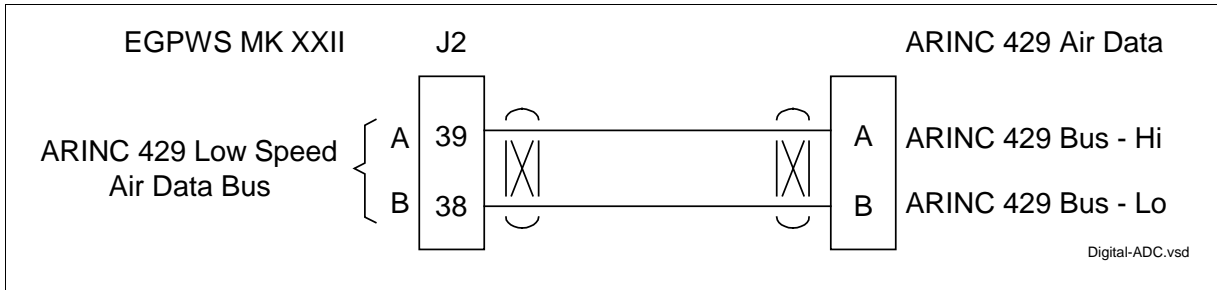

Vendor Model	Cat 2 ID	Bus 1		Bus 2	
		A	B	A	B
Sperry AZ-8XX	5*	J1B-26	J1B-27	J1B-70	J1B-71
CIC 04471	5*	J1-12	J1-13		
CIC 02702 mod 6	*	J2-J	J2-K		
KDC 281	*	P2811-5	P2811-6		
KDC 481	*	P4811-U	P4811- j		
B&D 90004	5*	J1-27	J1-9		
B&D 2600	*	6	8		
B&D 2601	*	14	13		
B&D 2800	*	P201-11	P201-28		
Collins ADC 85/86	5*	P2-9	P2-10	P2-29	P2-30
Shadin ADC-2000 (s/w mod 71.73.01)	5*	J1-40	J1-22		

NOTE: The connector pin numbers given in the Table above are to the best knowledge of Honeywell EGPWS engineering. Please contact the manufacturer's customer service to confirm your installation.

* Category 2, ID 5, 1 or 6 depending on availability of labels 204 and 212.

Honeywell
MK XXII EGPWS Installation Manual

3.3.2.5 Digital –ARINC 575 (Cat. 2 ID 2)

Air Data Type 2 (ADC-80 or equivalent) is a low speed, digital ARINC 575 signal having the air data labels 203, 206, 212, and 213.

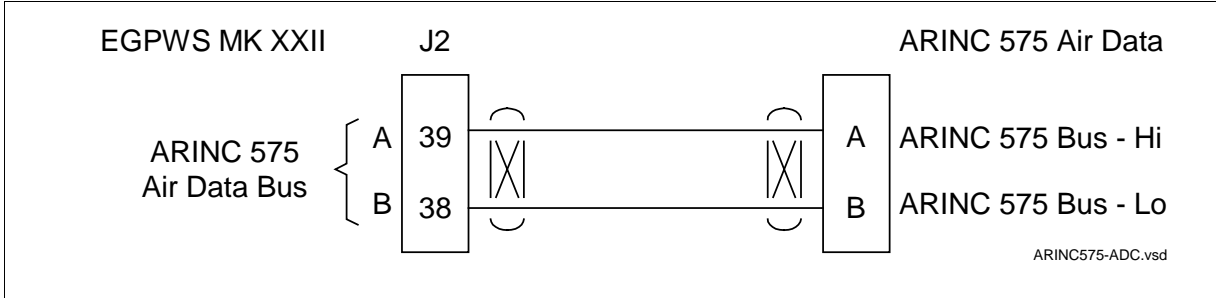

Vendor Model	Cat 2 ID	Bus 1		Bus 2	
		A	B	A	B
Collins ADC-80() Collins ADC-82A	2	P3-35	P3-36		
B&D 90004	2	J1-27	J1-9		

NOTE: The connector pin numbers given in the Table above are to the best knowledge of Honeywell EGPWS engineering. Please contact the manufacturer's customer service to confirm your installation.

Honeywell
MK XXII EGPWS Installation Manual

3.3.2.6 Shadin 2000 (Cat. 2 ID 10)

Air Data Type 10 (Shadin 2000 or equivalent) is a low speed, digital ARINC 429 signal having the air data labels 203, 204, 206, and 212. Total Air Temperature is from a dedicated (EGPWS) 500-ohm probe using +5 volt excitation from the MK XXII EGPWC.

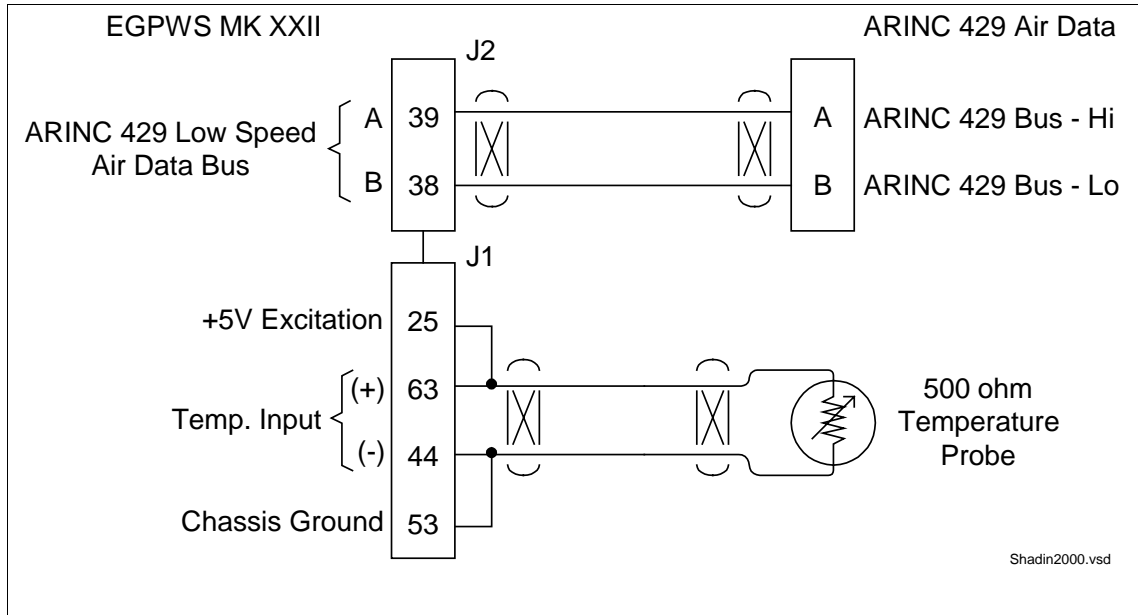

Vendor PN	Cat 2 ID	Bus 1		Bus 2	
		A	B	A	B
962830-1,2,3	10	J2-7	J2-8		
962830A-1,2,3 962830A-X-S-4 962830A-X-S-5 962830A-1-S-7(B212/412)	10	J1-40	J1-22		

NOTE: The connector pin numbers given in the Table above are to the best knowledge of Honeywell EGPWS engineering. Please contact the manufacturer's customer service to confirm your installation.

Honeywell
MK XXII EGPWS Installation Manual

3.3.2.7 Digital – ARINC 429 Dual IOC Buses (Cat. 2. ID 255)

Air Data Type 255 (IOC bus or equivalent) is a dual, high speed, digital ARINC 429 signal having the air data labels 203, 204, 206, 210, 212, and 213.

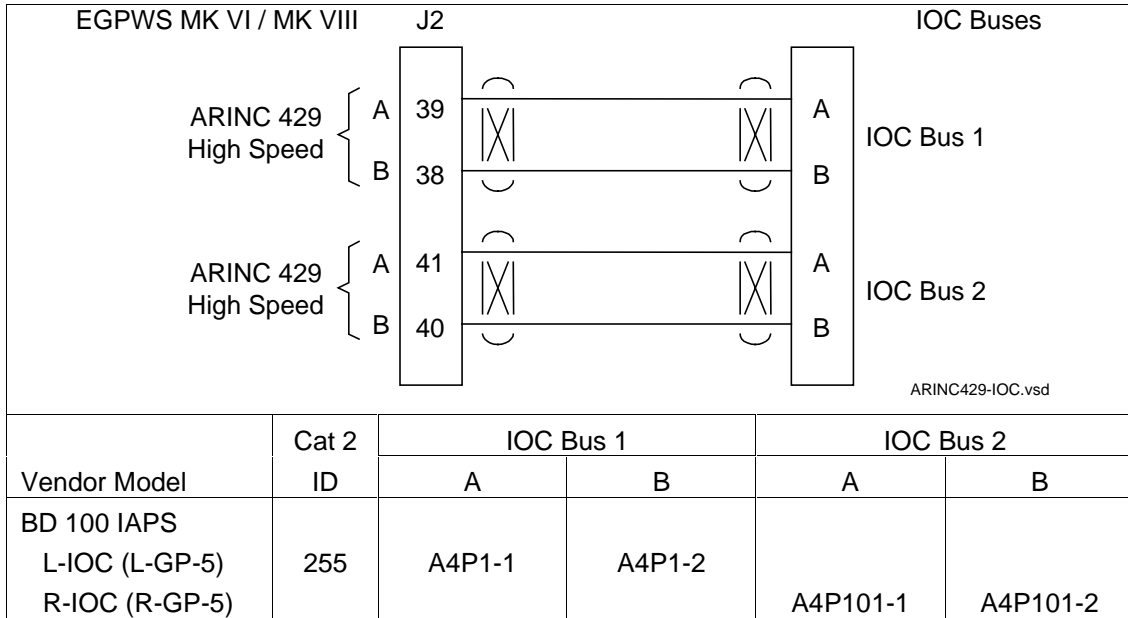

NOTE: The connector pin numbers given in the Table above are to the best knowledge of Honeywell EGPWS engineering. Please contact the manufacturer's customer service to confirm your installation.

3.3.3 Category 3 – Position Input Select

Category 3 defines the Global Position System bus type and interface. GPS Input selection is available in the following formats: ARINC 429 low speed and ARINC 429 high speed in either ARINC 743 or 743A format, RS-232, and Internal GPS card.

CAUTION

Not all GPS receivers calculate Horizontal Figure of Merit (HFOM) and Vertical Figure of Merit (VFOM) correctly and thus are unacceptable sources of position. The following GPS systems are known to have FOM computational errors:

Universal GPS-1000

3.3.3.1 Instructions

1. Using Appendix E Tables E 3, Under Step/category 3 select Position Input Source. Using table E 3.1.3 and E 3.1.3-x select ID number for your position input source and record that number on Table E 3 under Ident No. for step 3. This number will be used during programming of the configuration module.
2. Appendix E Tables E 3.1.3-x, where x is the position input type number, define the electrical interfaces required to support the position input type. Using Tables E 3.1.3-x determine the wiring interconnects and record it on Appendix A Fig A1-3.

Note: See Category 7 to select GPS Altitude Reference (mean sea level or WGS-84) for ARINC 429 label 076.

3.3.3.2 ARINC 743 Format

This option provides the ability to specify the GPS input data format as ARINC 743 instead of the ARINC 743A data format. For ARINC 743A the VFOM is in feet and the HFOM is in nautical miles (nm). For ARINC 743 both VFOM and HFOM are in meters.

Honeywell
MK XXII EGPWS Installation Manual

3.3.3.Examples

3.3.3.1 ARINC 429 BUS (Cat. 3 ID 0,1,4,5)

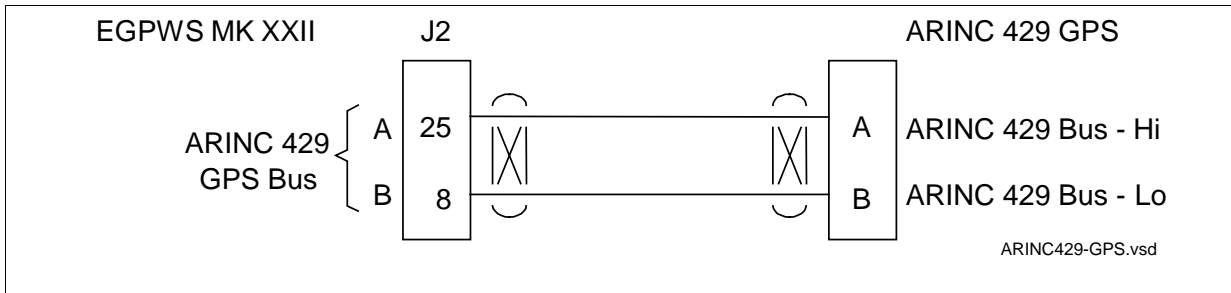

Vendor Model	429 Speed	GPS Alt Ref.	ARINC 743/743A	Bus 1		Bus 2	
				A	B	A	B
GNS-XLS (17960-0203-) or (17960-0102-) SM06	Low	MSL	743A	J101-N5 *	J101-N6 *		
GNS-XL (18355-) SM06	Low	MSL	743A	J101-N5	J101-N6		
HG2021GBXX	H/L**	MSL	743	J1-38	J1-39	J1-24	J1-25
HG2021GDXX	H/L**	MSL	743A	J1-38	J1-39	J1-24	J1-25

NOTE: The connector pin numbers given in the Table above are to the best knowledge of Honeywell EGPWS engineering. Please contact the manufacturer's customer service to confirm your installation.

- * GNS-XLS ARINC 429 bus also contains Range label
- ** Pin 21 open = high speed; Pin 21 GND = Low speed

3.3.3.2 RS-232 Transmit-Receive, 9600 baud (Cat. 3 ID 3)

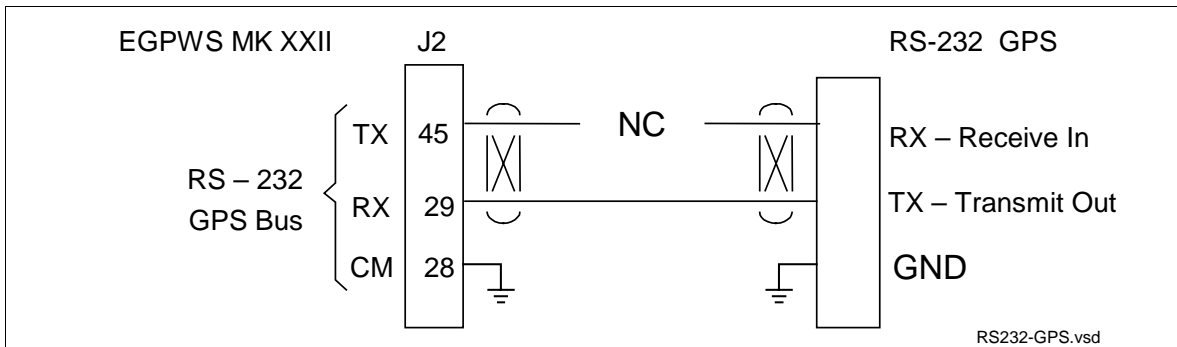

Vendor Model	GPS Alt Ref.	ARINC 743/743A	RS-232		
			RX	TX	GND
GARMIN GNS430 Software Version 2.21	MSL	N/A		P4001-56	Chassis
KLN 900 066-04034-0104 or 066-04034-0204	MSL	N/A		P9002-13	Chassis
KLN 94	MSL	N/A		P941-6	Chassis

NOTE: The connector pin numbers given in the Table above are to the best knowledge of Honeywell EGPWS engineering. Please contact the manufacturer's customer service to confirm your installation.

The KLN 90B is not compatible with EGPWS.

The GNS 430 software mod is also applicable to the GPS 400 and GNC 420 units.

Honeywell
MK XXII EGPWS Installation Manual

3.3.3.3 Dual ARINC 429 BUS (Cat. 3 ID 255)

NOTE: If GPS #2 is not installed in the aircraft, then GPS bus #1 must be connected in parallel to both EGPWS GPS input ports.

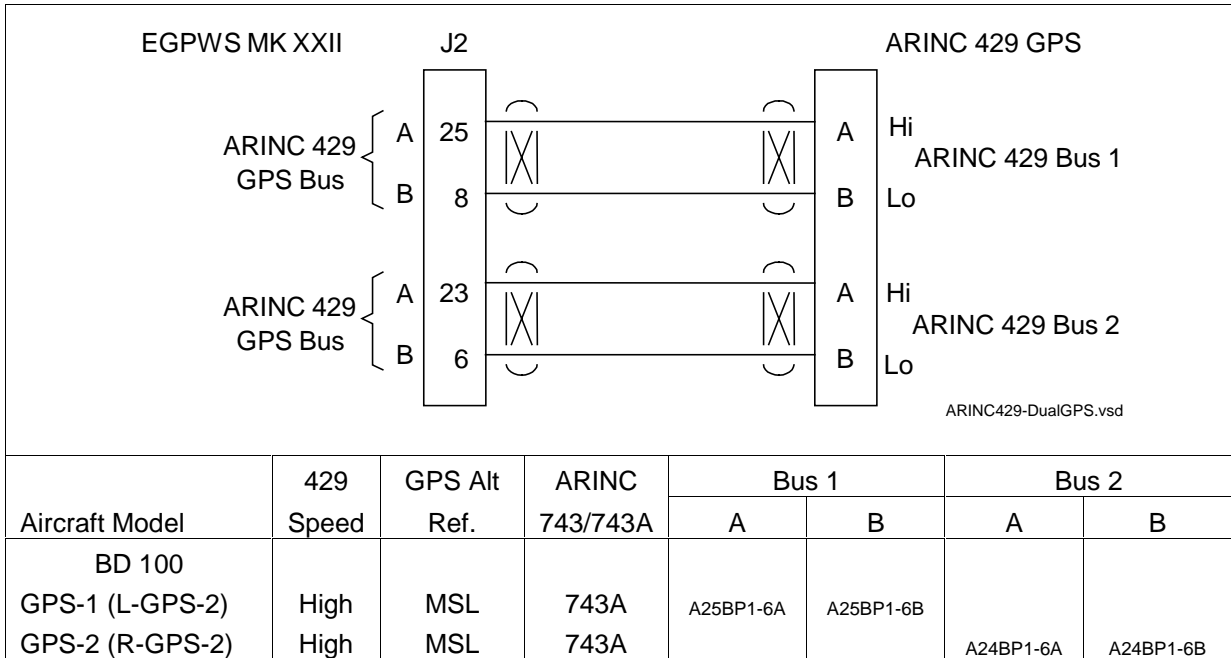

NOTE: The connector pin numbers given in the Table above are to the best knowledge of Honeywell EGPWS engineering. Please contact the manufacturer's customer service to confirm your installation.

Honeywell
MK XXII EGPWS Installation Manual

3.3.4 Category 4 – Altitude Callouts

Category 4 defines the Altitude Callout menu choices and Smart '500' Callout selection along with Autorotation callout enablement.

Appendix E Table E 3.1.4 defines the Altitude Callout Menu options and identifies the first MK XXII EGPWS version in which the option was available (see the Effectivity entry).

The Altitude callout menus have selected combinations of "Minimums-Minimums", Smart "500", "200", "100", "50", "40", "30", "20", and "10". Autorotation mode, and no altitude callouts may also be selected. Recommended selections are ID 133, 135 or 136.

NOTE: For applications that use Category 1 (Aircraft Type) ID 146, 147, 148 or 149, where autorotation will not be detected, it is strongly recommended that a callout menu be selected that provides, as a minimum, 200 and 100 feet such as ID 132 or 136.

The Altitude Callout menu provides altitude annunciation for descent below predefined altitudes (example: "One Hundred" is annunciated when descending through 100 feet radio altitude).

A Smart "500" foot callout is available that will issue a "500" callout when the aircraft is 500' AGL. This callout is active only during non-precision approaches or when the Glideslope or Localizer deviation is greater than 2 dots.

"Minimums-Minimums" callout can be selected or deselected from these combinations by connecting or not connecting the Decision Height (DH) discrete (J1-33) of Category 8.

3.3.4.1 Instructions

1. Using *Appendix E Table E 3.1.4*, select the preferred Altitude Callout Menu Type (ID) that matches the feature preferences and version (part number) being installed. Using table E 3.1.4 select ID number for your Altitude callouts and record that number on Table E 3 under Ident No. for step 4. This number will be used during programming of the configuration module.
2. If the "Minimums-Minimums" callout will be used, use the electrical interfaces (pin-outs) for Radio Altitude Input Select Type (Category 8) shown in *Appendix E Table E 3.1.8-x* to generate the installation wiring diagrams.

3.3.5 Category 5 – Audio Menu Select

Category 5 defines one Audio Menu options for Helicopters (ID 128).

3.3.5.1 Instructions

1. Using Appendix E Tables E 3, Under Step/category 5 select Audio Menu. Using table E 3.1.5, select ID number for your audio menu and record that number on Table E 3 under Ident No. This number will be used for programming the configuration module.
2. Audio Menu has no bearing on Aircraft wiring interface

3.3.6 Category 6 – Terrain Display Select

Category 6 defines the Terrain Display options available.

Appendix E *Table E 3.1.6* defines the Terrain Display Select options (***Display Configuration Group Tables, Display Input Control Group Tables*** and ***Output 429 Bus Group Tables***) and identifies the first MK XXII EGPWS version in which the option was available (see the Effectivity entry).

Note: TA&D mode *enabling/disabling* is controlled by Category 6. Chose ID 2 for aircraft without TA&D.

3.3.6.1 Instructions

1. Using Appendix E *Tables E3.1.6 and E 3.1.6-x* select the Terrain Display Select Type (ID) that matches the aircraft configuration, feature preferences and version (part number) being installed. Record the ID number for the Terrain Display Select Type from Appendix E *Table E 3* under the Ident No. heading for Step (Category) 6 .
2. Using the I D number *Table E 3.1.6* as “x”, go to the *Table E 3.1.6-x* . The electrical interfaces (pin-outs) for the Display are shown in the ***Display Configuration Group, Display Input Control Group, and Output 429 Bus Group, Table E 3.1.6-x*** are used to generate the installation wiring diagrams. Determine the wiring interconnects and record it on Appendix A Fig A1-1.

Figure 3.8-1 is an example of single tube Wx/Terrain display wiring connections.

3.3.6.2 TAD Selection

The Terrain Awareness & Display feature consists of a Terrain Awareness Alerting feature and a Terrain Awareness Display feature. The Terrain Awareness Alerting feature continuously computes terrain clearance envelopes ahead of the aircraft and issues alerts if the boundaries of these envelopes conflict with terrain elevation data in the terrain database. The Terrain Awareness Display feature displays the terrain data relative to aircraft altitude.

A “False” entry in Appendix E *Table E 3.1.6* for “TAD Disable” indicates that TA&D is ENABLED (the “Disable” is disabled).

Honeywell
MK XXII EGPWS Installation Manual

3.3.6.3 Terrain Display Configuration Group

This option provides the ability to specify the type of Terrain Display compatible with the aircraft configuration. A definition of each of the entries in the Display Configuration Group tables is provided in the table below.

Function	Value	Reference section
Display Type	<i>Display manufacturer, model, etc.</i>	
Sweep Type	<i>The type of sweep used for terrain data (fan, standard, etc.)</i>	
Auto Pop Up	Category 7, Options Select Group #1	
	TA&D Alternate Pop Up: False	TA&D Alternate Pop Up: True
	<i>The TA&D Alternate Pop Up is set to False or True in Category 7. If False, Pop Up behavior for the terrain display is described here.</i>	<i>The TA&D Alternate Pop Up is set to False or True in Category 7. If True, Pop Up behavior for the terrain display is described here.</i>
Peaks Mode See Note 1	Category 7, Options Select Group #1	
	Peaks Enable: False	Peaks Enable: True
	<i>Peaks Enable is set to False or True in Category 7. The effect of setting it to False is described here.</i>	<i>Peaks Enable is set to False or True in Category 7. The effect of setting it to True is described here.</i>
Manual select	<i>Describes if/when terrain display(s) can be manually selected</i>	
Manual deselect	<i>Describes if/when terrain display(s) can be manually deselected</i>	
Auto Range	<i>Defines if the display data is automatically scaled and, if so, the scale used (such as 10 nautical miles)</i>	
Moving Marker	<i>Indicates whether or not a moving marker is provided</i>	
Overlay Page	<i>Describes where "TERR" and Peaks Elevations overlays will be located on the display screen.</i>	
Display Priority	<i>Indicates the priority for displaying terrain data. For example: Standard (PWS Warn, Terrain Warn, PWS Caution, Terrain Caution)</i>	
Searchlights		
Display bus type	<i>Defines the display bus type 'KC Picture Bus' (ASPB), 'Honeywell Picture Bus' or 'ARINC 453'.</i>	
CHANNEL TX453-1	CONNECT TO:	
A = J1-58 B = J1-59	<i>Indicates the correct connection for these pins</i>	
CHANNEL TX453-2	CONNECT TO:	
A = J1-56 B = J1-57	<i>Indicates the correct connection for these pins</i>	

Notes: 1 Peaks Mode "(Not Available)" or "(Elevations via overlay)" shown here. Peaks mode "Not Available" means that this display type cannot display Peaks Mode.

Table 0-1 Definition of Display Configuration Group Tables (Appendix E Section 5.3.6)

Honeywell
MK XXII EGPWS Installation Manual

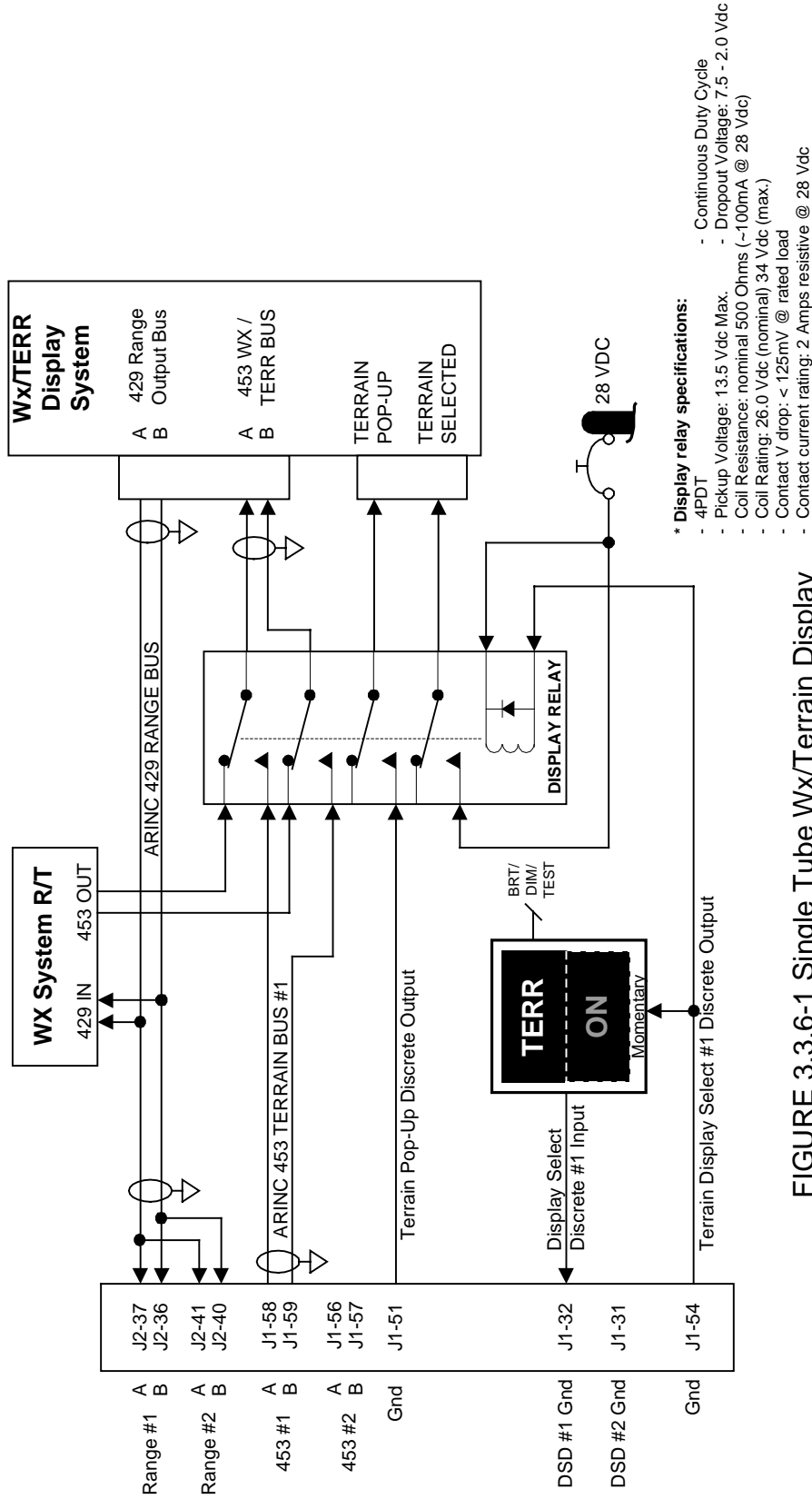

FIGURE 3.3.6-1 Single Tube Wx/Terrain Display

Honeywell
MK XXII EGPWS Installation Manual

3.3.6.4 Display Input Control Group

This input bus is connected to the display (or display controller) and transmits Range settings, Display Mode, and Display status to the MK XXII EGPWC.

3.3.6.5 Output 429 Bus Group

This output bus is commonly connected to EFIS and/or EICAS displays and Flight Recorders and transmits MK XXII EGPWC alert, fault, and mode status to other systems.

3.3.6.6 Example

**Honeywell
MK XXII EGPWS Installation Manual**

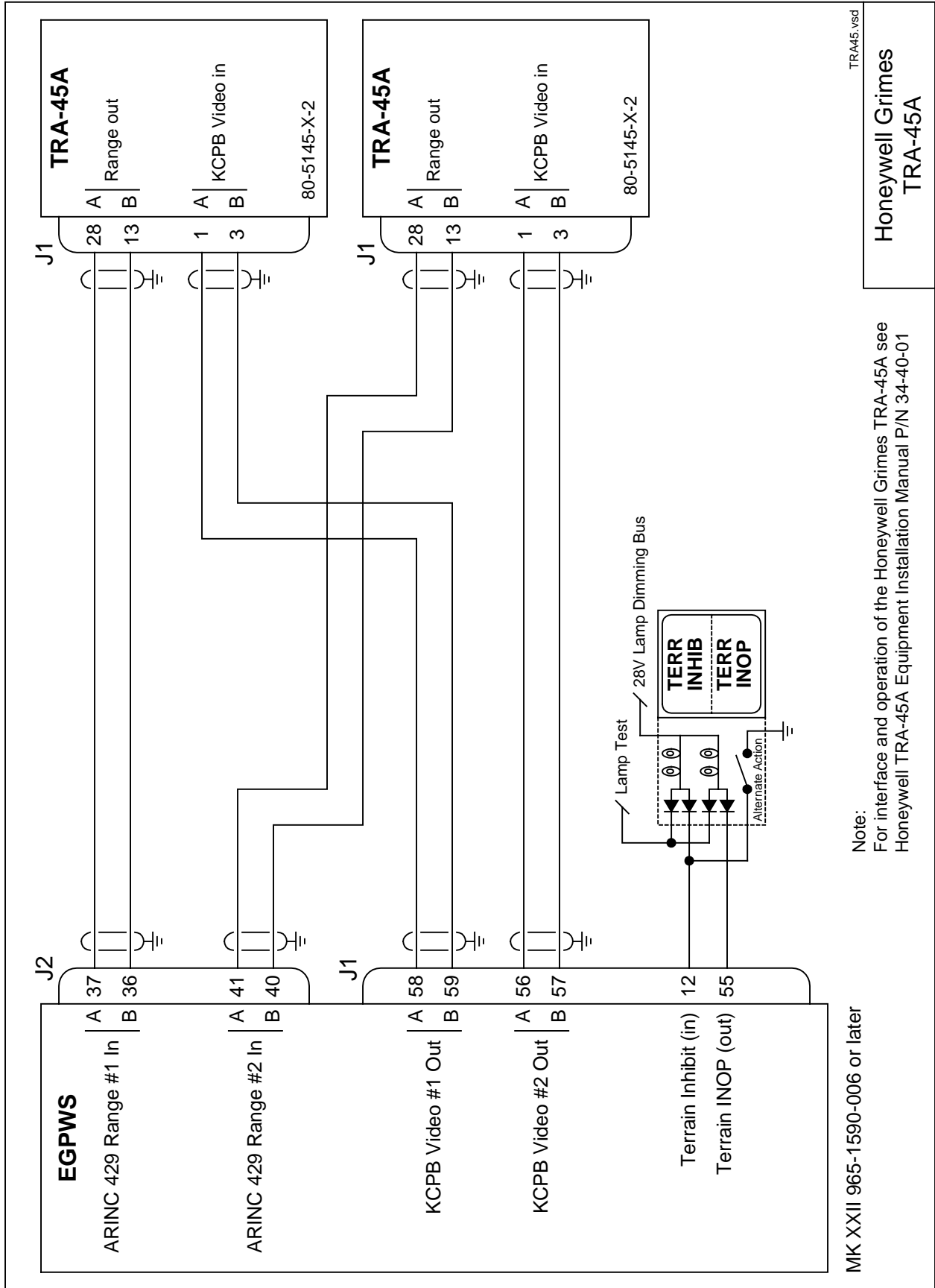

TRA45.vsd
**Honeywell Grimes
TRA-45A**

Note:
 For interface and operation of the Honeywell Grimes TRA-45A see
 Honeywell TRA-45A Equipment Installation Manual P/N 34-40-01

MK XXII 965-1590-006 or later

Honeywell
MK XXII EGPWS Installation Manual

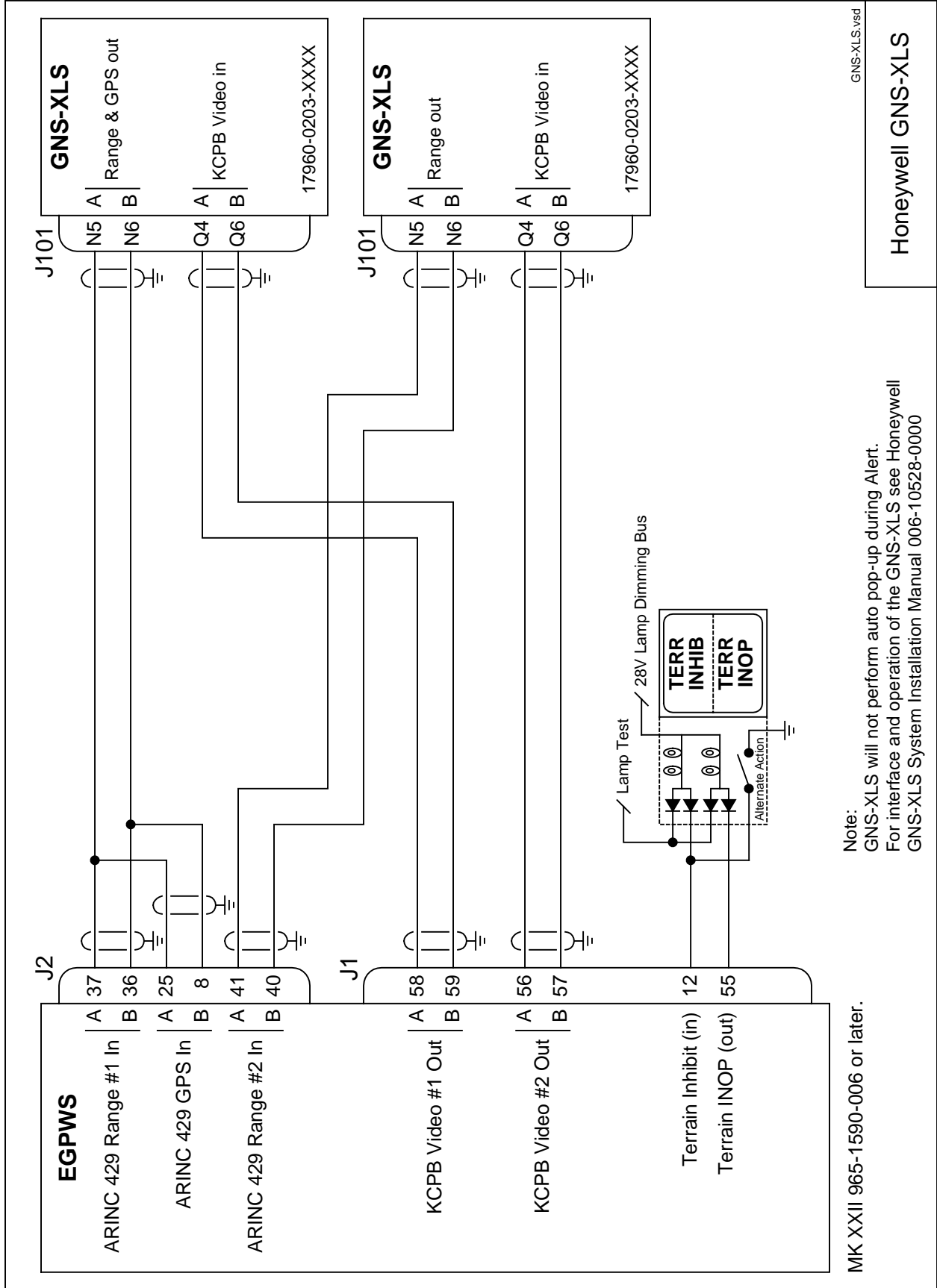

Honeywell
MK XXII EGPWS Installation Manual

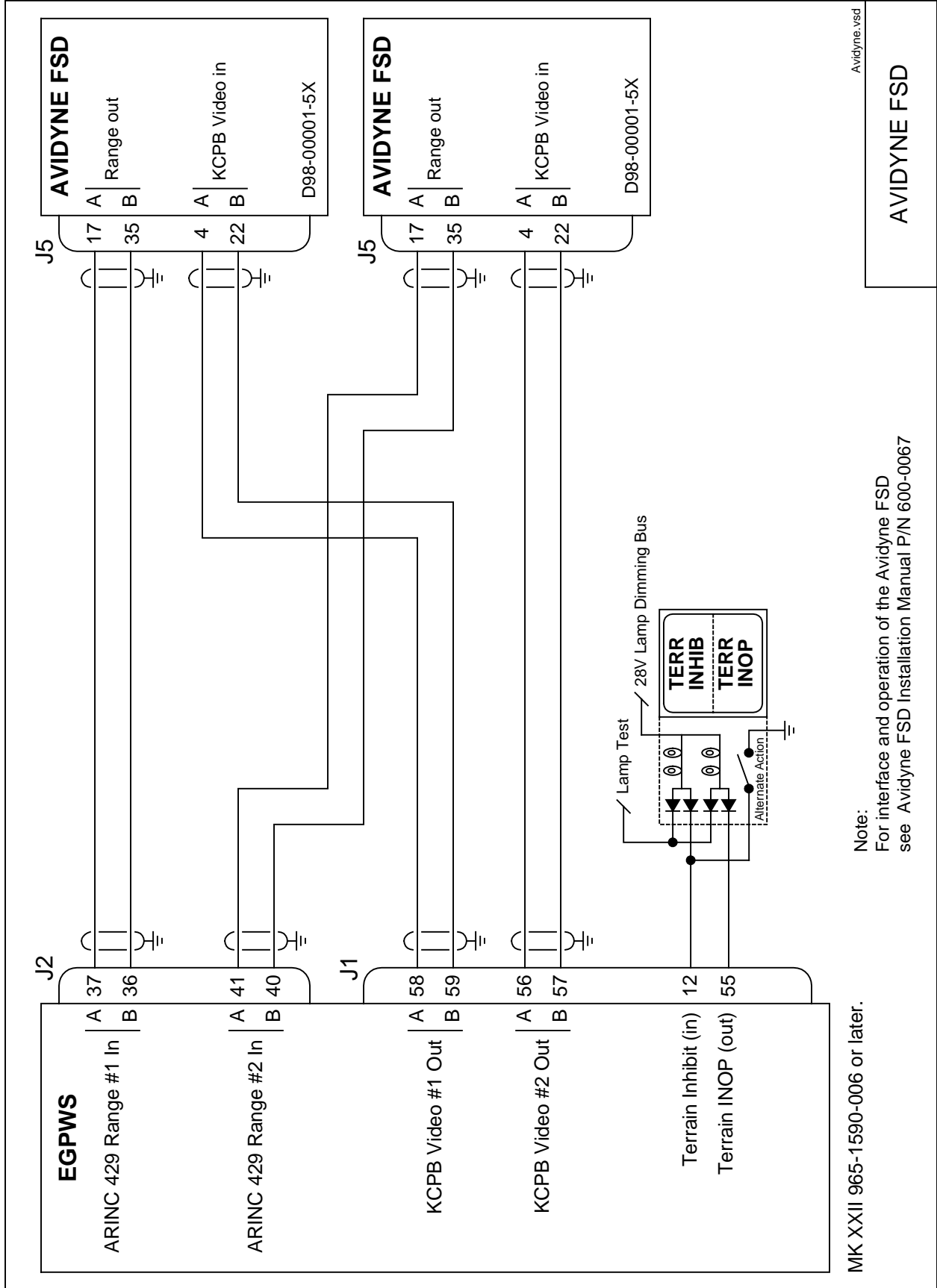

Honeywell
MK XXII EGPWS Installation Manual

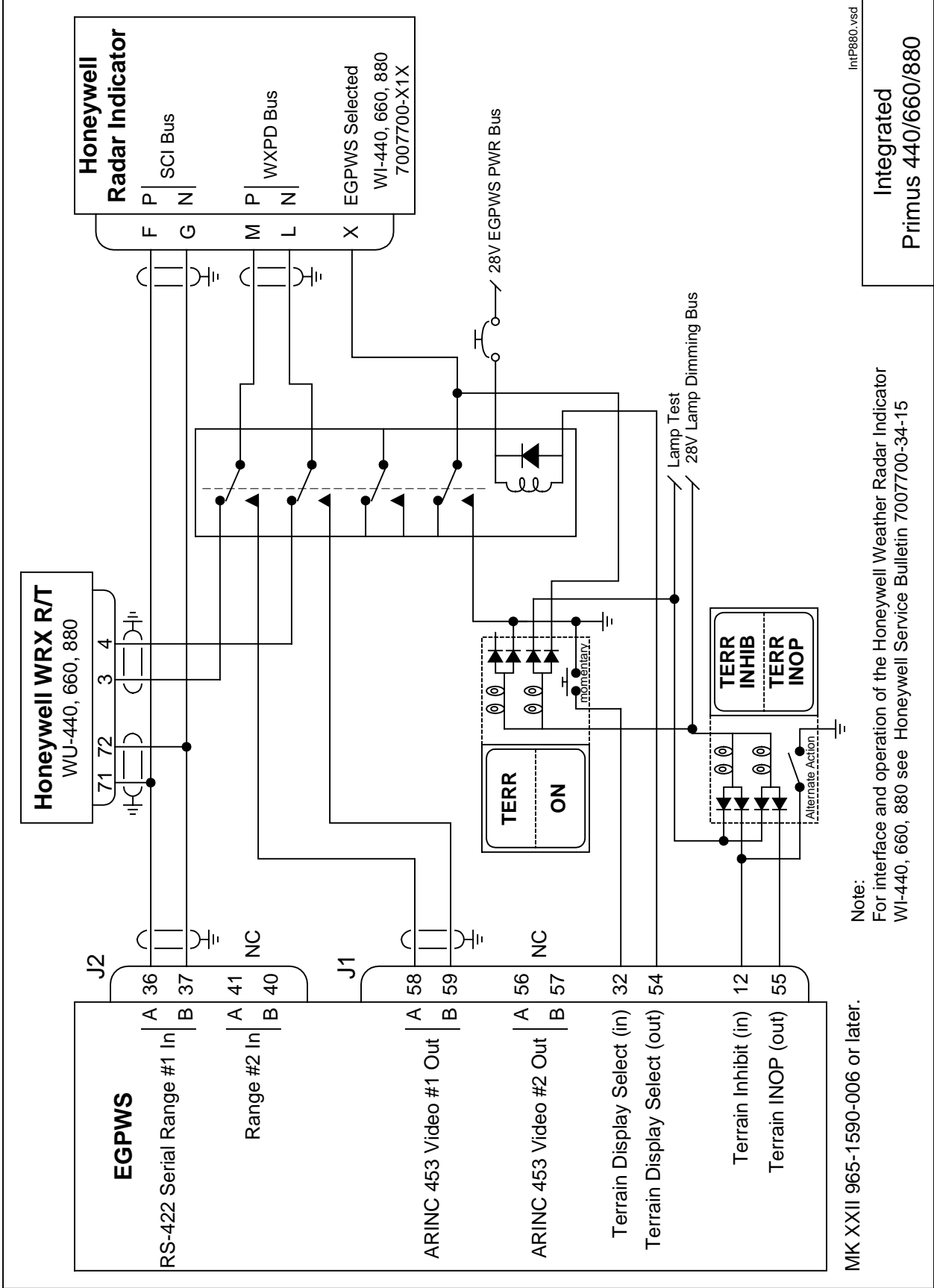

IntP880_vsd

Integrated
Primus 440/660/880

Note:
 For interface and operation of the Honeywell Weather Radar Indicator
 WI-440, 660, 880 see Honeywell Service Bulletin 7007700-34-15

MK XXII 965-1590-006 or later.

Honeywell
MK XXII EGPWS Installation Manual

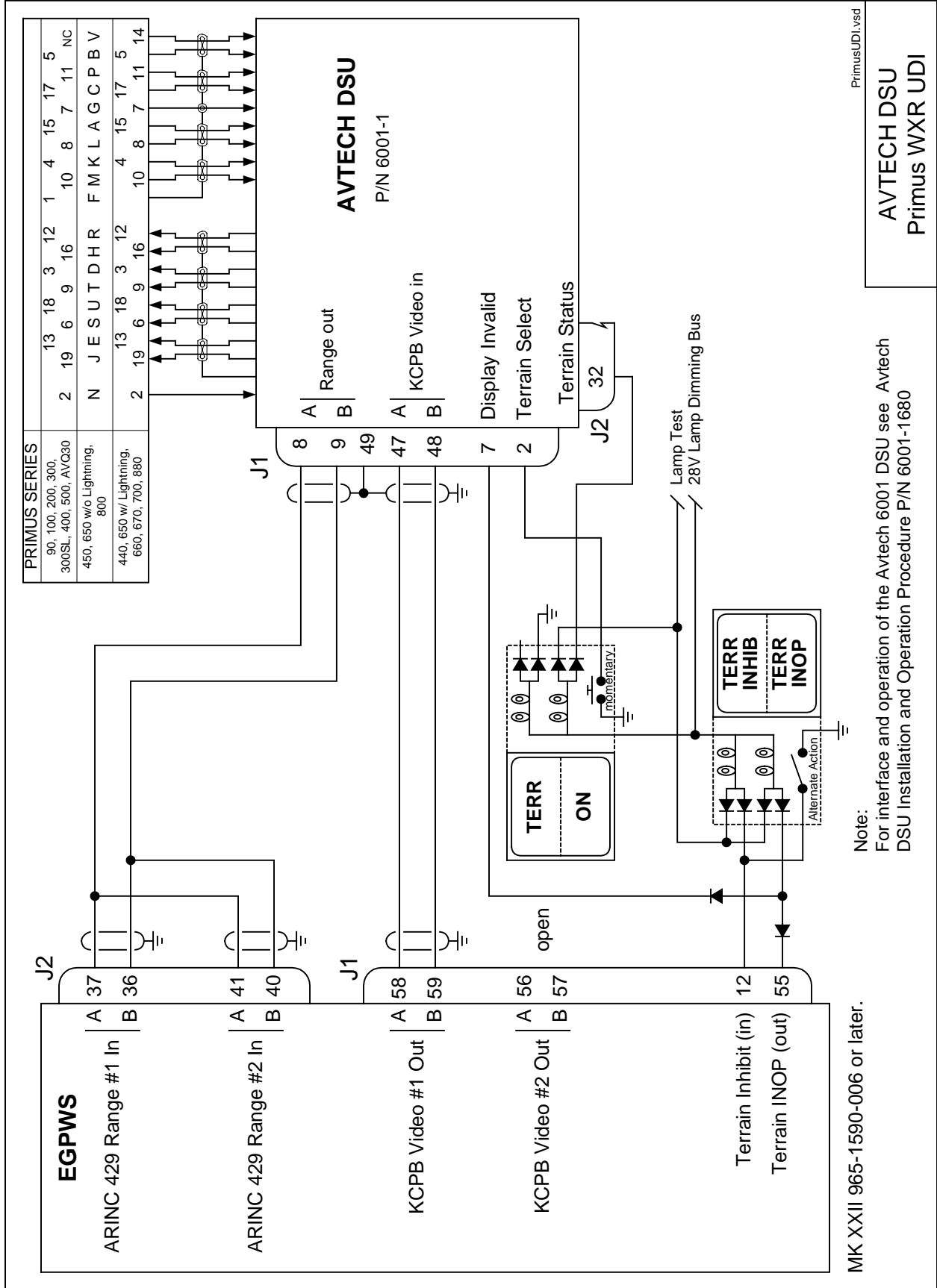

PrimusUDI.vsd

AVTECH DSU
Primus WXR UDI

Note:
 For interface and operation of the Avtech 6001 DSU see Avtech DSU Installation and Operation Procedure P/N 6001-1680

MK XXII 965-1590-006 or later.

3.3.7 Category 7 – Options Select Group #1

Category 7 enables/disables the following Options: Steep Approach (**not available in MkXXII**), TA&D Alternate Pop Up, Peaks Mode, Obstacle Awareness, Bank Angle, WOW Reversal, and GPS Altitude Reference.

Appendix E *Table E 3.1.7* defines the Options Select group and identifies the first MK XXII EGPWS version in which the option was available (see the Effectivity entry).

Note: **Disabling peaks mode is not an option in the Mk XXII**

3.3.7.1 Instructions

1. Review the sections below for information on Steep Approach, TA&D Pop Up, Peaks Mode, Obstacle Awareness, Bank Angle, WOW Reversal, and GPS Altitude Reference
2. Using Appendix E *Tables E 3.1.7*, select the preferred Category 7 (Options Select Group #1) ID that matches the aircraft configuration, features preferences and version (part number) being installed. Record the ID number for the Options Select Group #1 from Appendix E *Table E 3* under the Ident No. heading for Step (Category) 7. This number will be used for programming the configuration module

3.3.7.2 Steep Approach (Not Available in the Mk XXII)

This feature is not applicable to MK XXII.

3.3.7.3 TA&D Alternate Pop-up

The Display Configuration Group Type (Category 6) defines default and alternate definitions for EGPWS alert “Pop-up” behavior, when no terrain displays are active or when a combination of terrain and non-terrain displays are active. (Some Display Configuration Group Types do not support an Alternate Pop-up definition.)

Category 7 enables/disables Alternate Pop Up.

Pop-Up and Alternate Pop-Up

Defines whether EGPWC visual alerts will “pop-up” on displays not currently displaying terrain data. The entries are:

- | | |
|--------------|--|
| False | Selected terrain-compatible displays will switch to display surrounding terrain data. (Some displays will only Pop Up when display is in the proper mode.) |
| True | EGPWS alerts will not pop-up in terrain-compatible displays. |

Honeywell
MK XXII EGPWS Installation Manual

For Helicopters TA&D Alternate Pop Up should always be set to False.

3.3.7.4 Peaks Mode

Peaks mode is an alternate means of displaying terrain data. The standard terrain display mode displays terrain relative to the aircraft altitude that is within the aircraft envelope (the terrain is above or not more than 2000 feet below the aircraft). The terrain display is typically blank during the cruise portion of a flight. Peaks mode provides increased situational awareness by providing the same information as the standard display mode as well as displaying terrain outside of the aircraft envelope and the highest and lowest elevations of terrain displayed. Peaks mode displays terrain based on the absolute terrain elevations.

Disabling peaks mode is not an option in the Mk XXII. Peaks Mode is always selected.

3.3.7.5 Obstacle Awareness

The Obstacle Awareness feature adds a database of (man-made) obstacles that are greater than 100 feet taller than the surrounding terrain to the Terrain Awareness Alerting calculations. (The Terrain Awareness Alerting feature continuously computes terrain clearance envelopes ahead of the aircraft and issues alerts if the boundaries of these envelopes conflict with terrain elevation data in the terrain database.) Obstacle data is currently available for North America and parts of the Caribbean. Not all obstacles will be contained in the database.

Category 7 enables Obstacle Awareness if TA&D is not disabled in Category 6.

Note: TAD must be enabled if Obstacle Awareness is enabled.

Honeywell strongly recommends the selection of Obstacle Awareness.

3.3.7.6 Bank Angle Callout Enabling

The Bank Angle feature provides protection for over banking during maneuvering on approach or climb-out and while at altitude.. The Bank Angle callout can be enabled or disabled as appropriate for this installation.

Honeywell
MK XXII EGPWS Installation Manual

3.3.7.8 WOW Reversal

The WOW discrete input is defined in Category 13. The Category 7 control is used to reverse the defined logic to match aircraft wiring, if necessary.

+28 VDC WOW discrete active position:

WOW Discrete (Category 13)	WOW Reversal	
	Not Selected	Selected
WOW Discrete = +28V	WOW	Not WOW
WOW Discrete = Open	Not WOW	WOW

Ground seeking WOW discrete active position:

WOW Discrete (Category 13)	WOW Reversal	
	Not Selected	Selected
WOW Discrete = GND	WOW	Not WOW
WOW Discrete = Open	Not WOW	WOW

3.3.7.9 GPS Altitude Reference

The GPS Altitude (label 076, Category 3) may be referenced to mean sea level (MSL) or WGS-84. Determine which reference the GPS position uses and set the GPS Altitude Reference accordingly in this Category. If using the internal GPS card select MSL.

Honeywell
MK XXII EGPWS Installation Manual

3.3.8 Category 8 – Radio Altitude Input Select

Category 8 defines the Radio Altitude and Decision Height interface.

3.3.8.1 Instructions

1. Using Appendix E Tables E 3, under Step/category 8 select Radio Altitude Type. Using table E 3.1.8 and E 3.1.8-x select ID number for your Radio Altimeter and record that number on Table E 3 under Ident No. for step 8. This number will be used during programming of the configuration module.
2. Appendix E Tables E 3.1.8-x, where x is the Radio Altimeter Type number, define the electrical interfaces required to support each Radio Altimeter. Using Table E 3.1.8-x determine the wiring interconnects and record it on Appendix A Fig A1-1.
3. The Decision Height discrete (J1-33, Category 8) indicates to the MK XXII EGPWC whether the aircraft is above or below the selected Decision Height. This discrete is typically connected to the Decision Height output on the Radio Altimeter indicator. If the 'Minimums-Minimums' callout is not wanted the Decision Height discrete should be left open. Using Table E 3.1.8-x determine the wiring interconnects for Decision Height and record it on Appendix A Fig A1-1.

3.3.8.2 Example

3.3.8.3 Digital Radio Altitude Interface

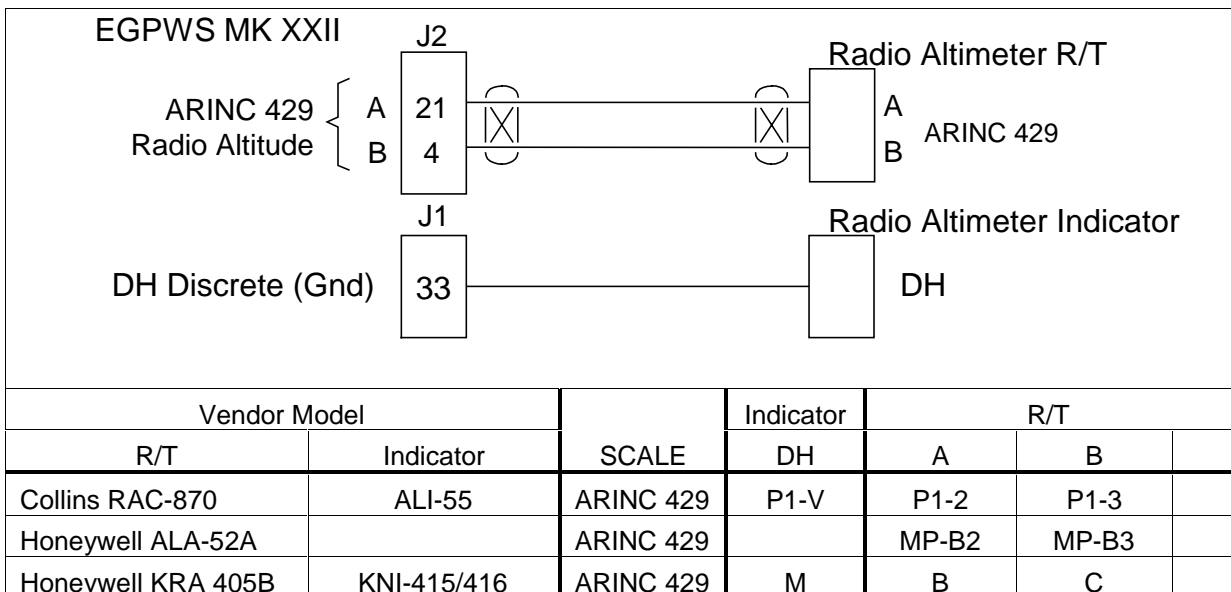

Honeywell
MK XXII EGPWS Installation Manual

3.3.8.4 Analog Radio Altitude Interface

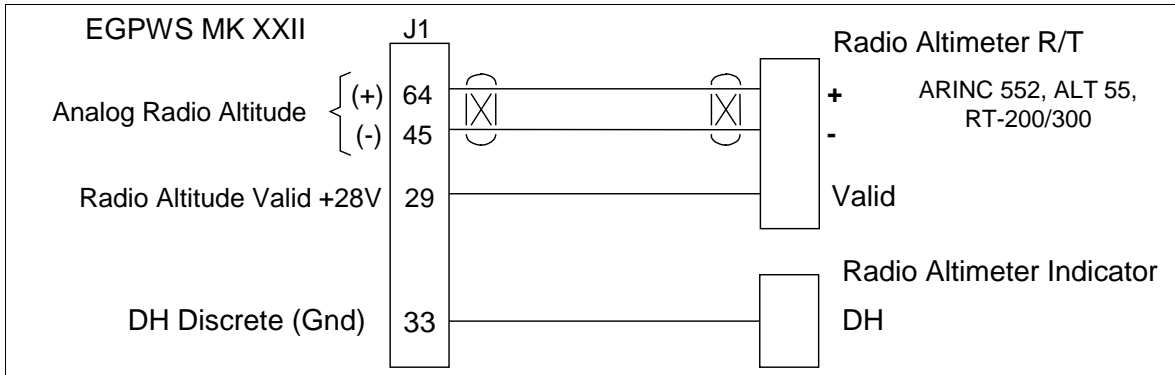

Vendor Model		SCALE	Indicator	R/T		
R/T	Indicator		DH	+	-	Valid
Collins ALT 55 ⁽³⁾	ALI-55	ALT55	P1-V	P1-57	P1-59	P1-49
Collins ALT 50		-20 to 2100 ft		P1-57	P1-59	P1-49
Honeywell HG7502	JG1072()	ARINC 552	P1- <u>e</u>	P4-47	P4-46	P4-27
Honeywell RT-300 ⁽¹⁾	RA-315	ARINC 552	P1-F	P1-X	P1-N	P1-Y
Honeywell RT-200 ⁽²⁾	RA-215	-.4mV/ft	P1-F	P1-N	P1-W	P1-Y
Honeywell KRA-405	KNI-415/416	ALT55	M	P1-B	P1-g	S
Honeywell KRA 405B	KNI-415/416	ALT55	M	E	X	j
KRA 405B ⁽²⁾ 066-01153-0101		-4mV/ft		G	Z	i
KRA 405B 066-01153-0202		ARINC 552A		Z	G	j
Honeywell ALA-51A	INA-51()	ARINC 552	P2- <u>e</u>	P1B-47	P1B-46	P1B-27
Collins 860F-1	339H-1/-2	ARINC 552	P1- <u>e</u>	P1B-47	P1B-46	P1B-27

NOTE 1: The following RT-300 part numbers meet ARINC 552 for the Auxiliary Output: 7001840 - 902, -906, -912, -916, -917, -918, -922, -926, -928, -932, -936, -937, and -938. Some RT-200's are also compatible, consult your Honeywell representative.

NOTE 2: This is the precision output from the R/T. Note the + and – signals are swapped to convert the –4mV to +4mV.

NOTE 3: The ALT-55 provides compromised EGPWS performance due to the average altitude tracking algorithm employed.

3.3.9 Category 9 – Navigation Inputs Select

Category 9 selects the Glideslope and Localizer Deviation interfaces and Glideslope Validity and ILS Tuned discretes.

Appendix E Table E 3.1.9 defines the Category 9 Navigation Inputs Select options (called Navigation Inputs Select Types) and identifies the first MK XXII EGPWS version in which the option was available (see the Effectivity entry).

3.3.9.1 Instructions

1. Using *Appendix E Tables E 3, E 3.1.9 and E 3.1.9-x* as described above, select the Navigation Input Select Type that matches the aircraft configuration, feature preferences, and version (part number) being installed.
2. Record the ID number for the Navigation Inputs Select Type from *Appendix E Table E 3* under the Ident No. heading for Step (Category) 9. This number will be used during programming of the configuration module.
3. Using the Navigation Inputs Select number from *Appendix E Table E 3.1.9* as “x”, go to *Appendix E Table E 3.1.9-x*. The electrical interfaces (pin-outs) for the Navigation Inputs Select Type are shown in *Appendix E Table E 3.1.9-x* and are used to determine the wiring interconnects and record it on Appendix A Fig A1-1.

Navigation Inputs Select (Glideslope & Localizer Inputs)

Glideslope Deviation is basic (required) and is available in analog and digital formats. Localizer Deviation is an enhancement (not required) and is available in digital format only.

Glideslope Validity

Glideslope Validity (+28V Super Flag) is required for Navigation Inputs Select 0 at pin J1-11.

Glideslope Validity (Low Level) is required for Navigation Inputs Select 1 at pins J1-30 (+) and J1-10 (-).

Digital 429 Glideslope interfaces (Navigation Inputs 2 & 3) do not require Glideslope Validity input.

ILS Tuned Discrete Input #1 (+28V) and #2 (GND)

The ILS Tuned Discrete indicates that an Instrument Landing System frequency has been selected on the Captain's (or selected) ILS. The ILS Tuned Discretes #1 (+28V) and #2 (GND) are optional to each other. These discretes are used with the analog Glideslope inputs. When an ILS is tuned, the MK XXII EGPWS checks the Glideslope Validity discretes and monitors the Glideslope inputs.

Honeywell
MK XXII EGPWS Installation Manual

3.3.9.2 Example

3.3.9.3 Analog Glideslope Interface (cat. 9 ID 0,1,5)

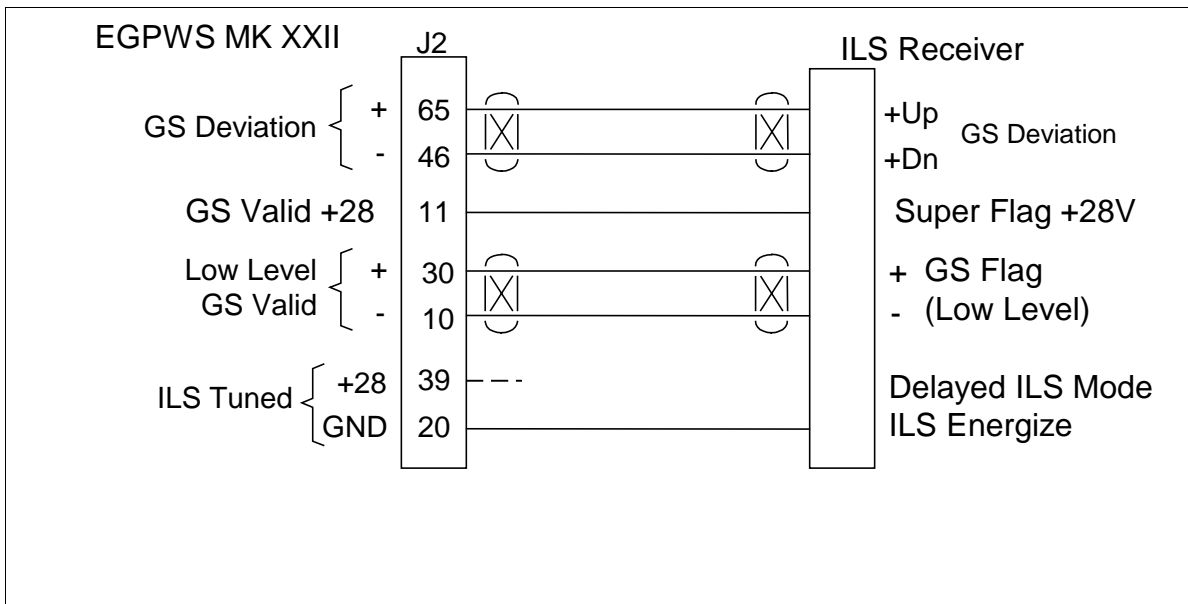

Vendor Model	Valid		ILS Tuned		Deviation	
	SuperFlag +28V	Low Level Flag	+28V	GND	GS +up/+dn	
Honeywell KNR 630	J1003-27	J1003-21 J1003-22		J1002-18	J1003-8 J1003-9	
Honeywell KNR 634	P6342-50	P6342-34 P6342-18		P6341-17	P6342-36 P6342-35	
Honeywell KGM-691		P692-S P692-T		P692-a	P692-B P692-C	
Honeywell KNR 600A		P601-e P601-g		P601-k	P601-r P601-s	
Collins 51RV-1		TP-22 TP-21		BP-18	TP-8 TP-9	
Collins VIR-30, -31, -32	P1-17	J1-9 J1-13		P2-40	P1-5 P1-1	
Honeywell VNS 41A	P1001-60			J1001-56	J1001-90 J1001-23	
Honeywell RNA-34A	TP-27	TP-21		BP-18	TP-8 TP-9	
Honeywell KN 53		P2-13 P2-R		P2-12	P2-P P2-14	
Honeywell RNZ 850	P1-A74			P1-B64	P1-B79 P1-B75	

Honeywell
MK XXII EGPWS Installation Manual

3.3.9.4 Digital Glideslope/Localizer Interface

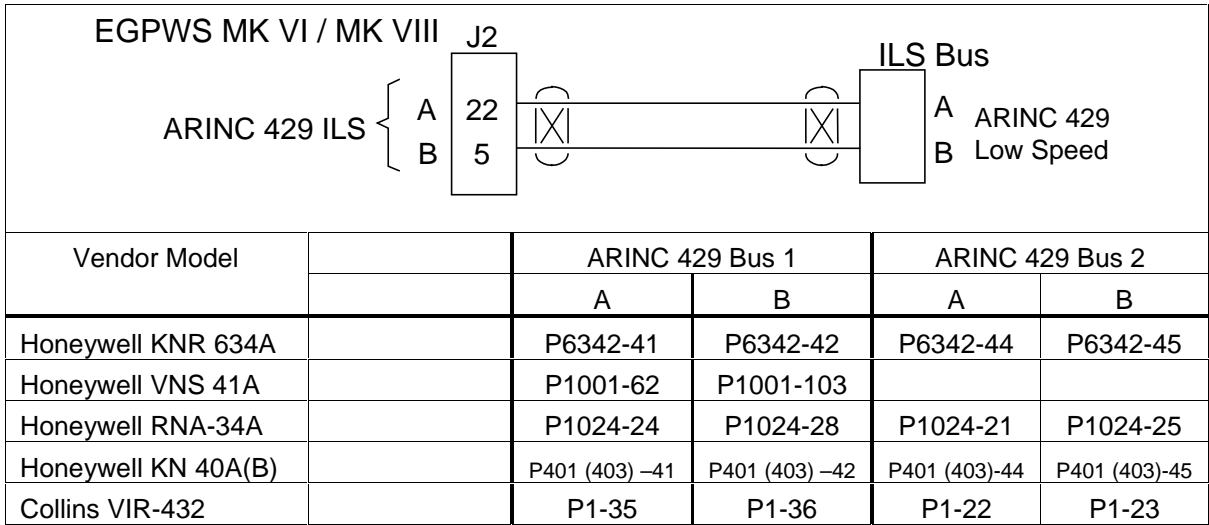

3.3.9.5 Dual Glideslope Receiver

An example of dual Glideslope receivers are shown on Fig A1-1 Appendix A

3.3.10 Category 10 – Attitude Input Select

Category 10 defines the Roll and Pitch Attitude interface.

3.3.10.1 Attitude Signals

Roll Angle is used for Bank Angle callout, Pseudo Altitude Algorithm and Terrain Awareness display.

Pitch Angle is used for the Tail Strike alert.

NOTE: For MD900 series aircraft where no Tail Strike alert is applicable, Pitch is not required, so a roll only configuration may be selected.

Appendix E Table E 3.1.10 defines the Attitude Input Select type and identifies the first MK XXII EGPWS version in which the option was available (see the Effectivity entry).

3.3.10.2 Instructions

1. Using *Appendix E Tables E 3 and Table E 3.1.10*, select the Attitude Input Select type that matches the aircraft configuration, feature preferences, and version (part number) being installed.
2. Record the ID number for the Attitude Input Select from *Appendix E Table E 3.1.10* under the Ident No. heading for Step (Category) 10 on Table E 3. This number will be used for programming the configuration module
3. Using the Attitude Input Select ID number from *Appendix E Table E 3.1.10* as “x”, go to *Appendix E Table E 3.1.10-x*. The electrical interfaces (pin-outs) for the Attitude Input Select Type are used to determine the wiring interconnects and record it on Appendix A Fig A1-3.

Honeywell
MK XXII EGPWS Installation Manual

3.3.10.3 Example

3.3.10.4 Analog Roll Angle (Synchro)

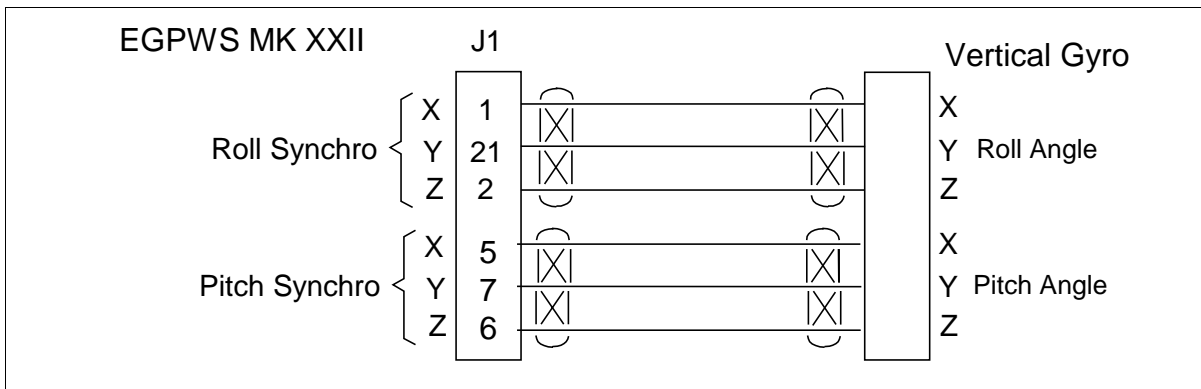

Vendor Model V/G	Attitude Valid +28	Pitch Synchro			Roll Synchro		
		X	Y	Z	X	Y	Z
Aeronetics RVG 801	P1-U	P1-A	P1-B	P1-C	P1-D	P1-E	P1-F
Collins AHC-85()	P1-13	P2-50	P2-51	P2-52	P2-42	P2-43	P2-44
Collins 332D-11	N	A	B	C	D	E	F
Honeywell HG1075		J1B-C9	J1B-C10	J1B-C11	J1B-D9	J1B-D10	J1B-D11
Jet VG-208	P1-U	P1-A	P1-B	P1-C	P1-D	P1-E	P1-F
King KVG-350	HH	<u>X</u>	<u>Y</u>	<u>Z</u>	<u>P</u>	<u>Q</u>	<u>R</u>
Litef LTR-81	MP-A11	MP-B1	MP-B2	MP-B3	MP-B4	MP-B5	MP-B6
Litef LCR-92& 93	Note 2	J3-11	J3-40	J3-26	J3-16	J3-39	J3-25
Sperry VG-14A	Note 3	<u>X</u>	<u>Y</u>	<u>Z</u>	<u>P</u>	<u>Q</u>	<u>R</u>
Sperry VG-311	P1-45	P1-5	P1-4	P1-6	P1-7	P1-8	P1-9

Note 1: The connector pin numbers given in the table above are to the best knowledge of Honeywell EGPWS engineering. Please contact the manufacturer's customer service to confirm your installation.

Note 2: See LCR installation manual.

Note 3: See airframe drawing.

Honeywell
MK XXII EGPWS Installation Manual

3.3.10.5 Digital ARINC 429 High Speed

Attitude Input ID 128 (Litef LCR 92S or equivalent) is a high speed, digital ARINC 429 signal having roll pitch angle, and roll pitch rate labels 325, 324, 327, and 326.

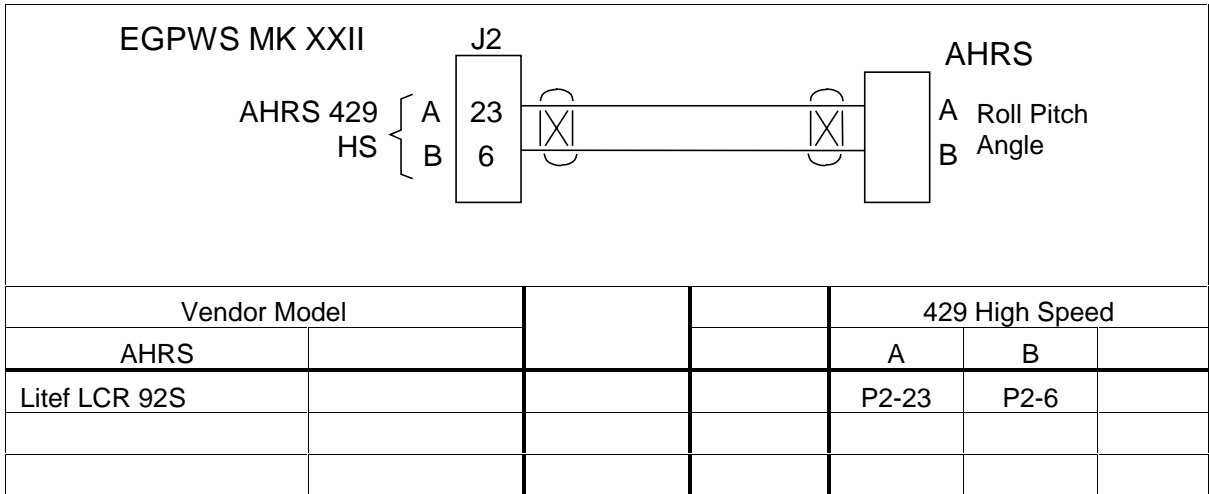

3.3.11 Category 11 – Heading Input Select

Category 11 defines the Magnetic Heading interface.

Appendix E Table E 3.1.11 defines the Heading Input Select types and identifies the first MK XXII EGPWS version in which the option was available (see the Effectivity entry).

3.3.11.1 Instructions

1. Using *Appendix E Tables E 3, E 3.1.11 and E 3.1.11-x*, select Heading Input type that matches the aircraft configuration, feature preferences, and version (part number) being installed.
2. Record the ID number for the Heading Input Select from *Appendix E Table E 3.1.11* under the Ident No. heading for Step (Category) 11 on Table E 3. This number will be used for programming the configuration module.
3. Using the Heading Input Select number from *Appendix E Table E 3.1.11* as “x”, go to *Appendix E Table E 3.1.11-x*. The electrical interfaces (pin-outs) for the Heading Input Select Type are shown in *Appendix E Table E 3.1.11-x* are used to determine the wiring interconnects and record it on Appendix A Fig A1-3.

3.3.11.2 Magnetic Heading

Magnetic Heading is used for Terrain Awareness alert and display and for Envelope Modulation.

Honeywell
MK XXII EGPWS Installation Manual

3.3.11.3 Example

3.3.11.3.1 Analog Heading (Synchro) (CAT. 11 ID 0)

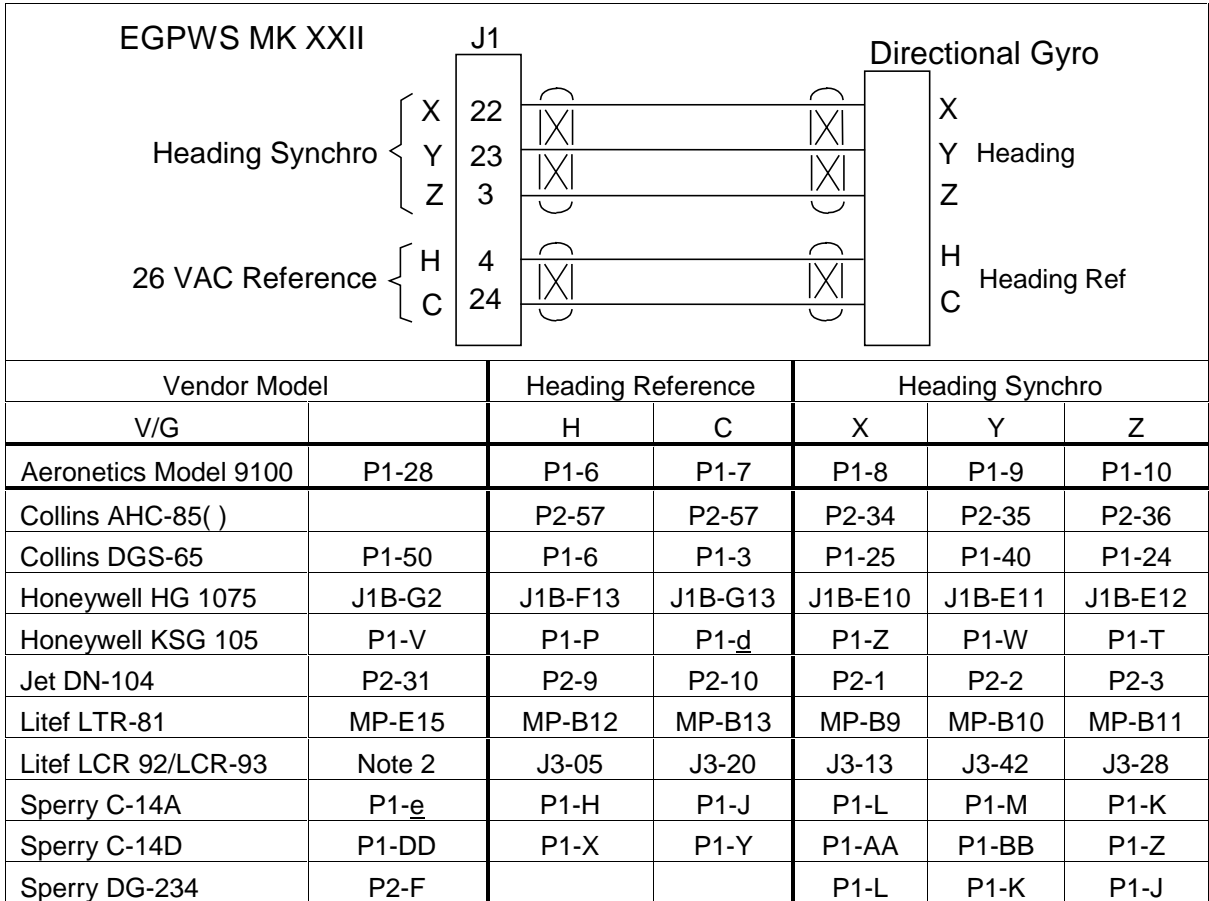

Note 1: The connector pin numbers given in the table above are to the best knowledge of Honeywell EGPWS engineering. Please contact the manufacturer's customer service to confirm your installation.

Note 2: See LCR installation manual.

Note 3: See airframe drawing.

Honeywell
MK XXII EGPWS Installation Manual

3.3.11.3.2 Digital ARINC 429 High Speed

Heading Input ID (Litef LCR 92S or equivalent) is a high speed, digital ARINC 429 signal having roll angle, pitch angle, roll rate, pitch rate, and heading labels 320, 325, 324, 327, and 326.

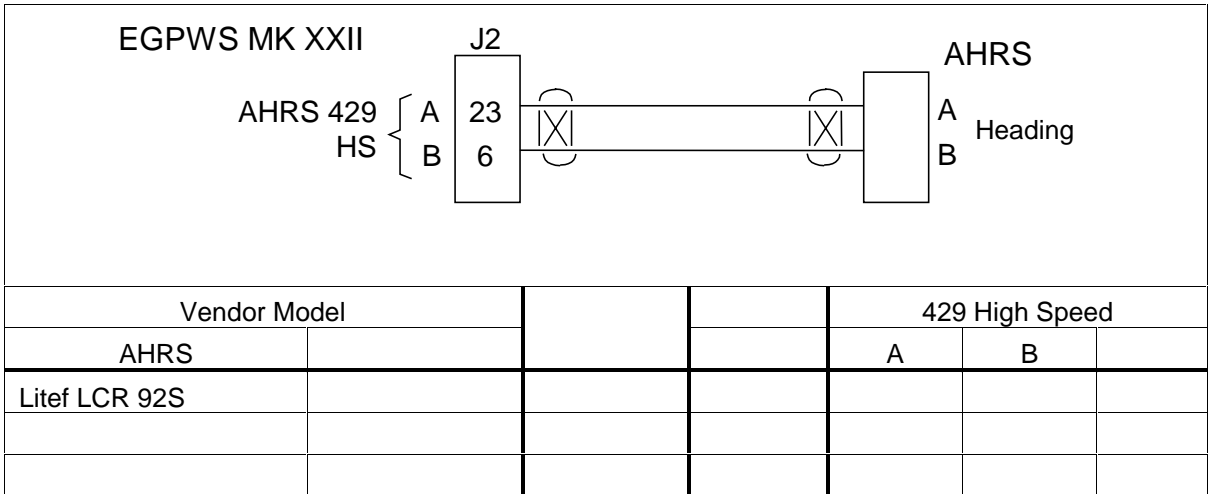

3.3.12 Category 12 – Windshear Input Select

Category 12 defines the Windshear interface.

Windshear is not applicable to MK XXII.

3.3.12.1 Instruction

Select ID 0 for all helicopter configurations.

3.3.13 Category 13 – Input / Output Discrete Type Select

Category 13 defines the input and output discretes not defined as part of any of the other Categories.

Appendix E Table E 3.1.13 defines the Input/Output discretes options and identifies the first MK XXII EGPWS version in which the option was available (see the Effectivity entry).

3.3.13.1 Instruction

1. Using *Appendix E Tables E 3, E 3.1.13, and E 3.1.13-x*, select the Input/Output Discrete Type number that matches the aircraft configuration, feature preferences and version (part number) being installed.

Note: Helicopter I/O Discrete options are Types 128 or 129. The difference is the Output Lamp format described below in section 3.3.13.3.1.

2. Record the ID number for the Input/Output Discrete Select number from *Appendix E Table E 3.1.13* under the Ident No. heading for Step (Category) 13 in *Appendix E Table E 3*. This number will be used for programming the configuration module.
3. Using the Input/Output Discrete Type number from *Appendix E Table E 3.1.13* as “x”, the *ICD Table E 3.1.13-x* is used to determine the wiring interconnects, record it on Appendix A Fig A1-1, A1-2, and A1-3.

Note: When there are two discrete pin choices for the same pin function in *Appendix E Table E 3.1.13-x*, use only the one that matches the aircraft wiring (use only the +28V and 0V or the Ground and Open definitions).

3.3.13.2 Input/Output Discretes

Additional information for the discretes is provided below.

Honeywell
MK XXII EGPWS Installation Manual

3.3.13.3 Audio Inhibit Discrete

The Audio Inhibit discrete is an optional input to maintain audio and visual prioritization. When activated, this discrete inhibits all audio (Ground Proximity and Terrain Awareness). Activation of the Audio Inhibit input for more than 60 seconds will result in the “All Modes Inhibit” fault.

The Audio Inhibit discrete input can be connected to any or all of the following (as applicable to the aircraft configuration):

- a separately labeled guarded cockpit switch

For some existing GPWS installations, this discrete may have been tied to the analog Radio Altimeter Receiver-Transmitter Self-Test output. This connection is no longer required but may be left intact for this installation.

Discrete	Position / Status	Connector Pin
Audio Inhibit +28	Inhibit = +28V Not Inhibit = Gnd/Open	J1-36

Honeywell does not recommend the use of this input for Helicopters.

3.3.13.4 Landing Gear Discrete

Landing Gear discrete is supplied by the Gear (or Gear handle) switch. The active position (+28V or GND) indicates “Gear Down” and should be connected to a contact that will indicate Gear Down when the Gear are lowered.

Discrete	Position / Status	Connector Pin
Landing Gear +28	Down = +28V Not Down = Gnd/Open	J1-35
Landing Gear Gnd	Down = Gnd Not Down = +28V /Open	J1-16

For fixed gear or skid equipped aircraft this input is not required.

3.3.13.5 Weight ON Wheels (WOW) Discrete

The Weight on Wheels (WOW) discrete is supplied by the WOW system in the aircraft. Connection can be made to the actual OLEO switch or relay logic later in the aircraft wiring.

For aircraft without WOW indication such as those with fixed gear or skids, this input discrete is not required.

Discrete	Position / Status	Connector Pin
WOW +28	On Ground = +28V In Air = Gnd/Open	J1-37
WOW Gnd	On Ground = Gnd In Air = +28V /Open	J1-18

Honeywell
MK XXII EGPWS Installation Manual

NOTE: The logic sense of the WOW discrete can be reversed by selecting the WOW eversal option in Category 7, see section 3.3.7.

3.3.13.6 Glideslope Cancel Discrete

The Glideslope Cancel discrete provides the crew with the capability to manually cancel Mode 5 for an approach. This is automatically reset when the aircraft descends below 30 feet or ascends above 2000 feet or by selecting a non-ILS frequency.

This discrete is typically supplied by a momentary action cockpit Glideslope mode manual inhibit switch, typically part of the Glideslope Lamp assembly (Below GS).

Discrete	Position / Status	Connector Pin
Glideslope Cancel	Cancel = Gnd Normal = Open	J1-15

3.3.13.7 Mode 6 Low Volume Discrete

The Mode 6 Low Volume discrete permanently or temporarily modifies the volume of the Mode 6 altitude and bank angle callouts. This discrete operates independent of the Category 14 options.

The Mode 6 Low Volume discrete is used to reduce the Mode 6 volume by 6dB from the volume level select in Category 14.

This discrete is typically connected to ground to lower the volume an additional 6dB. In some installations, it is connected to the windshield wiper control to decrease the Mode 6 Volume level under normal conditions and automatically increase Mode 6 volume 6dB when the cabin noise increases due to the windshield wipers being on.

Discrete	Position / Status	Connector Pin
Mode 6 Low Volume	Low Volume = Gnd Not Low Volume = Open	J1-13

3.3.13.8 Autopilot Engaged Discrete

For helicopters this discrete is currently not used.

Discrete	Position / Status	Connector Pin
Autopilot Engaged	Engaged = +28V Not Engaged = Open	J1-8

Honeywell
MK XXII EGPWS Installation Manual

3.3.13.9 Terrain Awareness Inhibit

The Terrain Awareness inhibit discrete, inhibits the Terrain Awareness modes in the MK XXII EGPWS.

This discrete is typically connected to an “alternate action switch” in the cockpit. The recommended label for this switch is “Terrain Override” although labeling for this switch should be consistent with existing cockpit nomenclature.

“Terrain Inhibited” will be annunciated during cockpit Self-Test if these functions are inhibited.

Discrete	Position / Status	Connector Pin
TA Inhibit	Inhibit = Gnd Not Inhibit = Open	J1-12

3.3.13.10 Self Test Discrete

The cockpit Self Test discrete is provided to manually initiate test of the EGPWC, EGPWS aircraft interface, and to annunciate system configuration and status information. This discrete is typically supplied by a momentary action cockpit ‘push to test’ switch, typically part of the GPWS WARN Lamp assembly.

This discrete must be momentarily connected to ground to activate the Self Test. Activation of this discrete continuously for more than 60 seconds will result in the ‘Self Test Invalid’ fault which will cause a GPWS INOP indication.

Discrete	Position / Status	Connector Pin
Self Test	Self Test = Gnd Normal = Open	J1-34

3.3.13.11 Glideslope Inhibit Discrete

The Glideslope Inhibit Discrete, also known as the Backcourse Inhibit, provides an inhibit to the Glideslope alert when on a backcourse approach.

The Glideslope Inhibit is usually connected to the Flight Director or FMS backcourse discrete output.

Discrete	Position / Status	Connector Pin
Glideslope Inhibit +28	Inhibit = +28V Not Inhibit = Gnd/Open	J1-38
Glideslope Inhibit Gnd	Inhibit = Gnd Not Inhibit = +28V /Open	J1-19

Honeywell
MK XXII EGPWS Installation Manual

3.3.13.12 Timed Audio Inhibit Discrete

The Timed Audio Inhibit will cause the inhibiting of all audio messages for a period of 5 minutes or until reset. The discrete input is connected to a momentary lighted switch. When pressed the condition is latched in memory and will be reset after 5 minutes have elapsed or pressing the switch again or when landing. The switch lighting, indicating the Audio is Inhibited is driven by a discrete output described below.

Discrete	Position / Status	Connector Pin
Timed Audio Inhibit	Momentary Toggle = Gnd Normal = Open	J1-17

NOTE: Either the Timed Audio Inhibit or the Terrain Inhibit should be used depending on the aircraft operations. See discussion in section 1.

3.3.13.13 Low Altitude Mode Select Discrete

The Low Altitude Mode select is a required input and is used for cruise operation below 500 feet AGL and for operation in high density metropolitan environments such as tall buildings. When selected, the Low Altitude Mode inhibits Excessive Terrain Closure (Mode 2) warnings, retards the Terrain Clearance warnings (Mode 4), and reduces the Terrain look ahead distances and width. When selected, Low Altitude Mode may be de-selected by pressing the switch again.

The Low Altitude select switch is a lighted momentary switch where the selected condition lighting is driven by an output discrete described below.

3.3.13.14 Output Discrettes

The discrete outputs are defined in *Appendix E Section 7.4*. The MK XXII EGPWS supports two kinds of Ground/Open discrete outputs used to indicate various conditions. Monitor outputs are used to indicate failure conditions for the EGPWS system. Monitor outputs default to an active state when there is a failure or if power is removed from the EGPWS (no connection if the EGPWC is removed from the rack). The Discrete Out Lamp driver outputs are used to indicate alert modes (GPWS WARN, BELOW GS, etc.) or mode control status (Terrain Display Select, etc.) of the EGPWS.

Short-term current limit protection is provided on all drivers for output shorting conditions. Ground going output discrettes may be connected together to produce a 'wired OR' function for the active low state of the outputs. If output discrettes are 'wire OR'd' then diodes must be installed for isolation.

3.3.13.15 Lamp Format

The Lamp Format Type (configuration) is a function of the discrete output pin functions and defines the operation of the red and amber GPWS cockpit lamps.

Honeywell
MK XXII EGPWS Installation Manual

For Lamp Format Type 1, the amber "Below G/S" lamp is driven by the GPWS Alert (Glideslope only) discrete and the red "GPWS" lamp is driven by the remaining alerts and warnings.

For Lamp Format Type 2, the red "EGPWS" lamp is driven by the GPWS Warning (Pull Up, Warning Terrain, and Warning Obstacle only) discrete and the amber "EGPWS" lamp is driven by the remaining alerts and warnings.

3.3.13.16 GPWS INOP Discrete

The GPWS INOP discrete (J1-72) indicates GPWS modes are inoperative. This feature activates a 'GPWS INOP' lamp located in the cockpit within sight of the pilots.

3.3.13.17 TAD INOP Discrete

The TAD INOP discrete (J1-55) indicates, Terrain Awareness (TA), and Terrain Display are 'Not Available'. This feature activates a 'TERRAIN INOP' lamp located in the cockpit within sight of the pilots.

3.3.13.18 GPWS Warning Discrete

(Lamp Format Type 1 definition)

GPWS Warning discrete (J1-78) will activate during any Mode 1 through Mode 4 alert or warning, Terrain Awareness caution/warning, and Obstacle Awareness caution/warning. This feature activates a 'GPWS' lamp located in the cockpit within sight of each pilot. Note that Mode 6 does not activate any lamp outputs, only voices.

3.3.13.19 GPWS Alert Discrete

(Lamp Format Type 1 definition)

GPWS Alert discrete (J1-77) will activate during Mode 5 Glideslope cautions only. This feature activates a 'BELOW GS' red lamp located in the cockpit within sight of each pilot.

3.3.13.20 Glideslope Cancel Discrete

-Optional- Glideslope Cancel discrete (J1-76) will activate when the Glideslope Cancel discrete (momentary) has been pressed any time below 2000 feet Radio Altitude if the ILS is tuned. This feature activates a 'G/S CAN' amber lamp located in the cockpit within sight of the pilots.

3.3.13.21 TCAS Inhibit Discrete

-Optional- TCAS Inhibit discrete (J1-69) will activate during any EGPWS voice annunciation. This output is used to inhibit TCAS from talking during EGPWS annunciation. This feature does not have a lamp associated with it.

Honeywell
MK XXII EGPWS Installation Manual

3.3.13.22 Terrain Display Select #1 & #2 Discrete

Terrain Display Select #1 & #2 discrete (J1-54 & J1-49) will activate after the related pilot has initiated manual selection of the Terrain Display Select (momentary) discrete #1 or #2 (J1-32 & J1-31, Category 6). This feature activates a ‘TERR’ white lamp located in the cockpit within sight of each pilot. The lamp serves to remind the flight crew that this function is active. The select switches (J1-32 & J1-31) and the indicator lamps (J1-54 & J1-49) are commonly combined in switch-lamp assemblies mounted near the displays being selected.

3.3.13.23 Timed Audio Inhibit Discrete

The Timed Audio Inhibit discrete (J1-52) will activate after a Timed Audio Inhibit switch (momentary) is pressed in the cockpit. The discrete will stay active until the Timed Audio Inhibit latch resets after 5 minutes or the switch is pressed again or the aircraft lands. The discrete is used to light the ON status portion of the Timed Audio Inhibit lighted switch assembly.

3.3.13.24 Low Altitude Mode Discrete

The Low Altitude Mode discrete (J1-73) will activate after a Low Alt switch (momentary) is pressed in the cockpit. The discrete is used to light the ON status portion of the Low Altitude lighted switch assembly. The discrete will stay active as long as the Low Altitude Mode is selected. The Low Altitude Mode may be de-selected by pressing the Low Alt switch again.

Honeywell MK XXII EGPWS Installation Manual

MkXXII EGPWS - COCKPIT LIGHTS

FUNCTION	SWITCH TYPE	NO.	ANNUNCIATOR DESCRIPTION (LAMP FORMAT TYPE 2)	CIRCUIT INTERCONNECT DIAGRAM MKXXII COMPUTER ANNUNCIATOR												
EGPWS - WARNING ALERT PRESS TO SELF TEST	MOM.	1	<table style="width: 100%; border-collapse: collapse;"> <tr> <td style="width: 33%;">OFF - Legend DAY Bgnd BLK</td> <td style="width: 33%;">Legend Bgnd BLK</td> <td style="width: 33%;">VIS WHT Bgnd BLK</td> </tr> <tr> <td style="width: 33%;">ON - NO DIM</td> <td style="width: 33%;">Legend Bgnd RED</td> <td style="width: 33%;">Legend Bgnd BLK</td> </tr> <tr> <td style="width: 33%;">ON - DIM 1 NIGHT</td> <td style="width: 33%;">Legend Bgnd GRN</td> <td style="width: 33%;">Legend Bgnd BLK</td> </tr> </table>	OFF - Legend DAY Bgnd BLK	Legend Bgnd BLK	VIS WHT Bgnd BLK	ON - NO DIM	Legend Bgnd RED	Legend Bgnd BLK	ON - DIM 1 NIGHT	Legend Bgnd GRN	Legend Bgnd BLK				
		OFF - Legend DAY Bgnd BLK	Legend Bgnd BLK	VIS WHT Bgnd BLK												
ON - NO DIM	Legend Bgnd RED	Legend Bgnd BLK														
ON - DIM 1 NIGHT	Legend Bgnd GRN	Legend Bgnd BLK														
2	<table style="width: 100%; border-collapse: collapse;"> <tr> <td style="width: 33%;">OFF - Legend DAY Bgnd BLK</td> <td style="width: 33%;">Legend Bgnd BLK</td> <td style="width: 33%;">VIS WHT Bgnd BLK</td> </tr> <tr> <td style="width: 33%;">ON - NO DIM</td> <td style="width: 33%;">Legend Bgnd RED</td> <td style="width: 33%;">Legend Bgnd BLK</td> </tr> <tr> <td style="width: 33%;">ON - DIM 1 NIGHT</td> <td style="width: 33%;">Legend Bgnd GRN</td> <td style="width: 33%;">Legend Bgnd BLK</td> </tr> </table>	OFF - Legend DAY Bgnd BLK	Legend Bgnd BLK	VIS WHT Bgnd BLK	ON - NO DIM	Legend Bgnd RED	Legend Bgnd BLK	ON - DIM 1 NIGHT	Legend Bgnd GRN	Legend Bgnd BLK						
OFF - Legend DAY Bgnd BLK	Legend Bgnd BLK	VIS WHT Bgnd BLK														
ON - NO DIM	Legend Bgnd RED	Legend Bgnd BLK														
ON - DIM 1 NIGHT	Legend Bgnd GRN	Legend Bgnd BLK														
EGPWS - CAUTION ALERT PRESS TO CANCEL G/S	MOM.	3	<table style="width: 100%; border-collapse: collapse;"> <tr> <td style="width: 33%;">OFF - Legend DAY Bgnd BLK</td> <td style="width: 33%;">Legend Bgnd BLK</td> <td style="width: 33%;">VIS WHT Bgnd BLK</td> </tr> <tr> <td style="width: 33%;">ON - NO DIM</td> <td style="width: 33%;">Legend Bgnd AMBER</td> <td style="width: 33%;">Legend Bgnd BLK</td> </tr> <tr> <td style="width: 33%;">ON - DIM 1 NIGHT</td> <td style="width: 33%;">Legend Bgnd GRN</td> <td style="width: 33%;">Legend Bgnd BLK</td> </tr> </table>	OFF - Legend DAY Bgnd BLK	Legend Bgnd BLK	VIS WHT Bgnd BLK	ON - NO DIM	Legend Bgnd AMBER	Legend Bgnd BLK	ON - DIM 1 NIGHT	Legend Bgnd GRN	Legend Bgnd BLK				
		OFF - Legend DAY Bgnd BLK	Legend Bgnd BLK	VIS WHT Bgnd BLK												
ON - NO DIM	Legend Bgnd AMBER	Legend Bgnd BLK														
ON - DIM 1 NIGHT	Legend Bgnd GRN	Legend Bgnd BLK														
4	<table style="width: 100%; border-collapse: collapse;"> <tr> <td style="width: 33%;">OFF - Legend DAY Bgnd BLK</td> <td style="width: 33%;">Legend Bgnd BLK</td> <td style="width: 33%;">VIS WHT Bgnd BLK</td> </tr> <tr> <td style="width: 33%;">ON - NO DIM</td> <td style="width: 33%;">Legend Bgnd AMBER</td> <td style="width: 33%;">Legend Bgnd BLK</td> </tr> <tr> <td style="width: 33%;">ON - DIM 1 NIGHT</td> <td style="width: 33%;">Legend Bgnd GRN</td> <td style="width: 33%;">Legend Bgnd BLK</td> </tr> </table>	OFF - Legend DAY Bgnd BLK	Legend Bgnd BLK	VIS WHT Bgnd BLK	ON - NO DIM	Legend Bgnd AMBER	Legend Bgnd BLK	ON - DIM 1 NIGHT	Legend Bgnd GRN	Legend Bgnd BLK						
OFF - Legend DAY Bgnd BLK	Legend Bgnd BLK	VIS WHT Bgnd BLK														
ON - NO DIM	Legend Bgnd AMBER	Legend Bgnd BLK														
ON - DIM 1 NIGHT	Legend Bgnd GRN	Legend Bgnd BLK														
EGPWS - CAUTION ALERT PRESS TO CANCEL G/S G/S CANCELLED	MOM.	5	<table style="width: 100%; border-collapse: collapse;"> <tr> <td style="width: 33%;">OFF - Legend DAY (GPWS) Bgnd BLK</td> <td style="width: 33%;">Legend Bgnd BLK</td> <td style="width: 33%;">VIS WHT Bgnd BLK</td> </tr> <tr> <td style="width: 33%;">ON - NO DIM</td> <td style="width: 33%;">Legend Bgnd AMBER</td> <td style="width: 33%;">Legend Bgnd BLK</td> </tr> <tr> <td style="width: 33%;">ON - DIM 1 (G/S)</td> <td style="width: 33%;">Legend Bgnd GRN</td> <td style="width: 33%;">Legend Bgnd BLK</td> </tr> <tr> <td style="width: 33%;">ON - DIM 2 (CAN)</td> <td style="width: 33%;">Legend Bgnd BLK</td> <td style="width: 33%;">Legend Bgnd BLK</td> </tr> </table>	OFF - Legend DAY (GPWS) Bgnd BLK	Legend Bgnd BLK	VIS WHT Bgnd BLK	ON - NO DIM	Legend Bgnd AMBER	Legend Bgnd BLK	ON - DIM 1 (G/S)	Legend Bgnd GRN	Legend Bgnd BLK	ON - DIM 2 (CAN)	Legend Bgnd BLK	Legend Bgnd BLK	
		OFF - Legend DAY (GPWS) Bgnd BLK	Legend Bgnd BLK	VIS WHT Bgnd BLK												
ON - NO DIM	Legend Bgnd AMBER	Legend Bgnd BLK														
ON - DIM 1 (G/S)	Legend Bgnd GRN	Legend Bgnd BLK														
ON - DIM 2 (CAN)	Legend Bgnd BLK	Legend Bgnd BLK														
6	<table style="width: 100%; border-collapse: collapse;"> <tr> <td style="width: 33%;">OFF - Legend DAY (GPWS) Bgnd BLK</td> <td style="width: 33%;">Legend Bgnd BLK</td> <td style="width: 33%;">VIS WHT Bgnd BLK</td> </tr> <tr> <td style="width: 33%;">ON - NO DIM</td> <td style="width: 33%;">Legend Bgnd AMBER</td> <td style="width: 33%;">Legend Bgnd BLK</td> </tr> <tr> <td style="width: 33%;">ON - DIM 1 (G/S)</td> <td style="width: 33%;">Legend Bgnd GRN</td> <td style="width: 33%;">Legend Bgnd BLK</td> </tr> <tr> <td style="width: 33%;">ON - DIM 2 (CAN)</td> <td style="width: 33%;">Legend Bgnd BLK</td> <td style="width: 33%;">Legend Bgnd BLK</td> </tr> </table>	OFF - Legend DAY (GPWS) Bgnd BLK	Legend Bgnd BLK	VIS WHT Bgnd BLK	ON - NO DIM	Legend Bgnd AMBER	Legend Bgnd BLK	ON - DIM 1 (G/S)	Legend Bgnd GRN	Legend Bgnd BLK	ON - DIM 2 (CAN)	Legend Bgnd BLK	Legend Bgnd BLK			
OFF - Legend DAY (GPWS) Bgnd BLK	Legend Bgnd BLK	VIS WHT Bgnd BLK														
ON - NO DIM	Legend Bgnd AMBER	Legend Bgnd BLK														
ON - DIM 1 (G/S)	Legend Bgnd GRN	Legend Bgnd BLK														
ON - DIM 2 (CAN)	Legend Bgnd BLK	Legend Bgnd BLK														
LOW ALTITUDE MODE PRESS TO ENGAGE	MOM.	7	<table style="width: 100%; border-collapse: collapse;"> <tr> <td style="width: 33%;">OFF - Legend DAY Bgnd BLK</td> <td style="width: 33%;">Legend Bgnd BLK</td> <td style="width: 33%;">VIS WHT Bgnd BLK</td> </tr> <tr> <td style="width: 33%;">ON - DIM 1 NIGHT</td> <td style="width: 33%;">Legend Bgnd GRN</td> <td style="width: 33%;">Legend Bgnd BLK</td> </tr> <tr> <td style="width: 33%;">ON - DIM 2</td> <td style="width: 33%;">Legend Bgnd GRN</td> <td style="width: 33%;">Legend Bgnd BLK</td> </tr> </table>	OFF - Legend DAY Bgnd BLK	Legend Bgnd BLK	VIS WHT Bgnd BLK	ON - DIM 1 NIGHT	Legend Bgnd GRN	Legend Bgnd BLK	ON - DIM 2	Legend Bgnd GRN	Legend Bgnd BLK				
OFF - Legend DAY Bgnd BLK	Legend Bgnd BLK	VIS WHT Bgnd BLK														
ON - DIM 1 NIGHT	Legend Bgnd GRN	Legend Bgnd BLK														
ON - DIM 2	Legend Bgnd GRN	Legend Bgnd BLK														
TERRAIN INHIBIT PRESS TO INHIBIT	ALT.	8	<table style="width: 100%; border-collapse: collapse;"> <tr> <td style="width: 33%;">OFF - Legend DAY Bgnd BLK</td> <td style="width: 33%;">Legend Bgnd BLK</td> <td style="width: 33%;">VIS WHT Bgnd BLK</td> </tr> <tr> <td style="width: 33%;">ON - DIM 1 NIGHT</td> <td style="width: 33%;">Legend Bgnd GRN</td> <td style="width: 33%;">Legend Bgnd BLK</td> </tr> <tr> <td style="width: 33%;">ON - DIM 2</td> <td style="width: 33%;">Legend Bgnd GRN</td> <td style="width: 33%;">Legend Bgnd BLK</td> </tr> </table>	OFF - Legend DAY Bgnd BLK	Legend Bgnd BLK	VIS WHT Bgnd BLK	ON - DIM 1 NIGHT	Legend Bgnd GRN	Legend Bgnd BLK	ON - DIM 2	Legend Bgnd GRN	Legend Bgnd BLK				
OFF - Legend DAY Bgnd BLK	Legend Bgnd BLK	VIS WHT Bgnd BLK														
ON - DIM 1 NIGHT	Legend Bgnd GRN	Legend Bgnd BLK														
ON - DIM 2	Legend Bgnd GRN	Legend Bgnd BLK														
AUDIO INHIBIT PRESS TO INHIBIT	MOM.	9	<table style="width: 100%; border-collapse: collapse;"> <tr> <td style="width: 33%;">OFF - Legend DAY Bgnd BLK</td> <td style="width: 33%;">Legend Bgnd BLK</td> <td style="width: 33%;">VIS WHT Bgnd BLK</td> </tr> <tr> <td style="width: 33%;">ON - DIM 1 NIGHT</td> <td style="width: 33%;">Legend Bgnd GRN</td> <td style="width: 33%;">Legend Bgnd BLK</td> </tr> <tr> <td style="width: 33%;">ON - DIM 2</td> <td style="width: 33%;">Legend Bgnd GRN</td> <td style="width: 33%;">Legend Bgnd BLK</td> </tr> </table>	OFF - Legend DAY Bgnd BLK	Legend Bgnd BLK	VIS WHT Bgnd BLK	ON - DIM 1 NIGHT	Legend Bgnd GRN	Legend Bgnd BLK	ON - DIM 2	Legend Bgnd GRN	Legend Bgnd BLK				
OFF - Legend DAY Bgnd BLK	Legend Bgnd BLK	VIS WHT Bgnd BLK														
ON - DIM 1 NIGHT	Legend Bgnd GRN	Legend Bgnd BLK														
ON - DIM 2	Legend Bgnd GRN	Legend Bgnd BLK														
TERRAIN SELECT PRESS TO SELECT	MOM.	10	<table style="width: 100%; border-collapse: collapse;"> <tr> <td style="width: 33%;">OFF - Legend DAY Bgnd BLK</td> <td style="width: 33%;">Legend Bgnd BLK</td> <td style="width: 33%;">VIS WHT Bgnd BLK</td> </tr> <tr> <td style="width: 33%;">ON - DIM 1 NIGHT</td> <td style="width: 33%;">Legend Bgnd GRN</td> <td style="width: 33%;">Legend Bgnd BLK</td> </tr> <tr> <td style="width: 33%;">ON - DIM 2</td> <td style="width: 33%;">Legend Bgnd GRN</td> <td style="width: 33%;">Legend Bgnd BLK</td> </tr> </table>	OFF - Legend DAY Bgnd BLK	Legend Bgnd BLK	VIS WHT Bgnd BLK	ON - DIM 1 NIGHT	Legend Bgnd GRN	Legend Bgnd BLK	ON - DIM 2	Legend Bgnd GRN	Legend Bgnd BLK				
OFF - Legend DAY Bgnd BLK	Legend Bgnd BLK	VIS WHT Bgnd BLK														
ON - DIM 1 NIGHT	Legend Bgnd GRN	Legend Bgnd BLK														
ON - DIM 2	Legend Bgnd GRN	Legend Bgnd BLK														
GPWS SYSTEM VALIDITY GPWS / TERR	X	11	<table style="width: 100%; border-collapse: collapse;"> <tr> <td style="width: 33%;">OFF - Legend DAY Bgnd BLK</td> <td style="width: 33%;">Legend Bgnd BLK</td> <td style="width: 33%;">VIS WHT Bgnd BLK</td> </tr> <tr> <td style="width: 33%;">ON - DIM 2</td> <td style="width: 33%;">Legend Bgnd AMBER</td> <td style="width: 33%;">Legend Bgnd BLK</td> </tr> <tr> <td style="width: 33%;">ON - DIM 2</td> <td style="width: 33%;">Legend Bgnd AMBER</td> <td style="width: 33%;">Legend Bgnd BLK</td> </tr> </table>	OFF - Legend DAY Bgnd BLK	Legend Bgnd BLK	VIS WHT Bgnd BLK	ON - DIM 2	Legend Bgnd AMBER	Legend Bgnd BLK	ON - DIM 2	Legend Bgnd AMBER	Legend Bgnd BLK				
OFF - Legend DAY Bgnd BLK	Legend Bgnd BLK	VIS WHT Bgnd BLK														
ON - DIM 2	Legend Bgnd AMBER	Legend Bgnd BLK														
ON - DIM 2	Legend Bgnd AMBER	Legend Bgnd BLK														

DIMMER EXPLANATION: DIM 1 = VISIBLE WHITE LEGEND PWR (0 VDC DAY/+16 VDC NIGHT)
DIM 2 = DEADFACE LEGEND PWR (+28 VDC DAY/+16 VDC NIGHT)

REVISED: 6-25-01

Table 0-1 MKXXII EGPWS – Example Cockpit Lights

Honeywell
MK XXII EGPWS Installation Manual

3.3.14 Category 14 – Audio Output Level

Category 14 controls the Audio Output level for alert menu callouts (cautions and warnings). Refer to Category 13 for information on the Mode 6 Low Volume discrete.

Appendix E Table E 3.1.14 defines the Audio Output Level options and identifies the first MK VI/VIII EGPWS version in which the option was available (see the Effectivity entry).

3.3.14.1 Instructions

1. Using *Appendix E Tables E 3 and E 3.1.14* as described above, select the Audio Output Level ID number that matches the feature preferences and version (part number) being installed.
2. Record the ID number for the Audio Output Level from *Appendix E Table E 3.1.14* under the Ident No. heading for Step (Category) 14 in *Appendix E Table E 3*.

The Nominal Volume Select is equivalent to MK XXII MAX volume level. The –6dB through –24 dB are successively lower volume from Nominal. The Nominal output is 4 watts rms into an 8-ohm load and 100 milli-watts rms into a 600-ohm load. The audio output level for Mode 6 alerts can be reduced an additional 6 dB by activating the Mode 6 Low Volume discrete of Category 13.

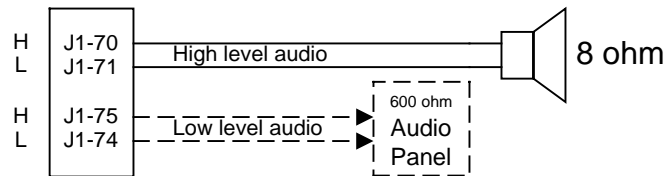

FIGURE 3.16-1 Audio Interface

Note: Because most helicopters use a full muff headset, cockpit speakers are not applicable.

3.3.15 Category 15, Autorotation Threshold

Category 15 controls the Autorotation Threshold level used for Autorotation detection. Actual thresholds are determined during first of type flight. The thresholds are found in Table 3.1.15-1-1 below.

Appendix E Table E 3.1.15 defines the Autorotation threshold options.

3.3.15.1 Instruction

1. Using Table 3.1.15-1-1 below and *Appendix E Tables E 3 and E 3.1.15* as described above, select the Autorotation threshold torque ID number that was determined during flight test.
2. Record the ID number for the Autorotation threshold torque Level from Table 3.1.15-1 or Table 3.1.15-1 below under the Ident No. heading for Step (Category) 15 in *Appendix E Table E 3*.

Honeywell
MK XXII EGPWS Installation Manual

AUTOROTATION THRESHOLD

Aircraft Type ID	Aircraft Model	Threshold %	Threshold ID
128	S-76 B/C+	7.5	15
129	S-76C/A++	7.5	15
130	S-76A/A+	7.5	15
131	Bell 212	6	12
131	Bell 412	6	12
132	EC-155B	7.5	15
133	MD900	7.5	15
133	MD902	7.5	15
134			
135			
136	AS 365N3	7.5	15
137			
138			
139			
140			
141	Bell 412, DC Torque	6	12
142			
143			
144			
145			

Table 3.1.15-1: Autorotation Thershold

SECTION IV
CONFIGURATION MODULE PROGRAMMING
AND
REGIONAL TERRAIN DATABASE LOADING

SECTION IV – CONFIGURATION MODULE PROGRAMMING AND REGIONAL TERRAIN DATABASE LOADING

SECTION IV – CONFIGURATION MODULE PROGRAMMING AND REGIONAL TERRAIN DATABASE LOADING	109
4.1 INTRODUCTION	109
4.2 HARNESS CHECKOUT AND POWER CHECK	109
4.3 UNIT INSTALLATION	109
4.4 EGPWC INITIALIZATION AND CONFIGURATION	109
4.4.1 RS-232 Communication with the MK XXII EGPWS	109
4.4.2 EGPWC Front Panel Test Connector	110
4.4.3 WinVIEWS	110
4.4.4 WinVIEWS Operation	111
4.5 CONFIGURATION MODULE PROGRAMMING	111
4.5.1 CUW and CMR Commands	113
4.5.2 Configuration Module Reprogramming	114
4.6 REGIONAL TERRAIN DATABASE LOADING	115
4.6.1 Effectivity	115
4.6.2 Description	115
4.6.3 Approval	115
4.6.4 Material – Cost and Availability	116
4.6.5 Accomplishment Instructions	117
4.6.6 Verification of the Terrain Database Version	118

SECTION IV – CONFIGURATION MODULE PROGRAMMING AND REGIONAL TERRAIN DATABASE LOADING

4.1 Introduction

The following procedures outline the steps necessary to accomplish a complete configuration of the MK XXII EGPWS. This section must be accomplished in the order presented to minimize errors in configuring and operating the system(s). If problems are encountered in performing these procedures, the installer may refer to aircraft wiring diagrams for harness troubleshooting or the aircraft maintenance manual to isolate faulty equipment. All discrepancies should be resolved before proceeding. This section will also load the Regional Terrain Database in MK XXII EGPWS that will be operating outside of the North American region.

4.2 Harness Checkout and Power Check

Prior to installing any equipment, it is important to verify that all interfaces have been made and that power and ground at each unit connector is correct, using the wiring diagrams for the installation. Any discrepancies in the wiring must be resolved before proceeding.

The wire harness should also be checked for proper clearance near any control cables and other potential areas that may cause binding and/or chafing.

4.3 Unit Installation

After the harness check has been completed and any discrepancies have been resolved, the units should be installed into their respective racks, and all connections to the wiring harness should be made (connectors attached). Verify that all of the units are secure in their respective racks, panels, etc., and all harness connections are secure. Refer to aircraft installation drawings for the unit locations and mounting information.

4.4 EGPWC Initialization and Configuration

The first time a MK XXII EGPWS is turned on in a new installation, the Configuration Module in the EGPWS harness must be programmed to the specific interface configuration for the aircraft. This programming is done via RS-232 cable connection between the EGPWC and a PC running the Honeywell WinViews software. This interface capability is provided to facilitate diagnostic and configuration functions with the EGPWC during post installation checkout. Refer to Appendix C for instructions related to using the WinViews software.

4.4.1 RS-232 Communication with the MK XXII EGPWS

The MK XXII EGPWS computer contains software that allows monitoring of its internal

Honeywell
MK XXII EGPWS Installation Manual

parameters, for testing purposes, without altering its operation. The monitoring of these parameter values enables the operator to quickly determine if the EGPWC is using the correct signal and scaling. The communication link utilizes the RS-232 communication protocol configured as follows:

19200 Baud, No Parity, 8 Bits, and 1 Stop Bit

4.4.2 EGPWC Front Panel Test Connector

The RS-232 interface with the EGPWC is accomplished via a test connector provided on the EGPWC front panel (J3). This provides access for a PC test monitor and portable data loading capabilities. The mating connector for the EGPWC test plug (P3) is a male, 15 pin, double density D-subminiature type (or equivalent).

The connection between the PC serial port connector (with standard DB9) and the EGPWC RS-232 interface is defined as follows:

	RS-232 Receive	RS-232 Transmit	RS-232 Ground
EGPWS Front Connector (J3)	Pin 3	Pin 4	Pin 1
Standard (PC)* DB9 Connector	Pin 3	Pin 2	Pin 5

***NOTE:** Some PC Comm Ports have Pins 2 & 3 reversed from what is described above.

Connector, AMP 205161-1
Socket Contact, AMP 205090-1, QTY 3

Connector, AMP 748364-1
Pin Contact, 204370-2, QTY 4
Backshell, AMP 745854-5
Jackscrew, AMP 747784-3
Grommet Set, AMP 747746-1

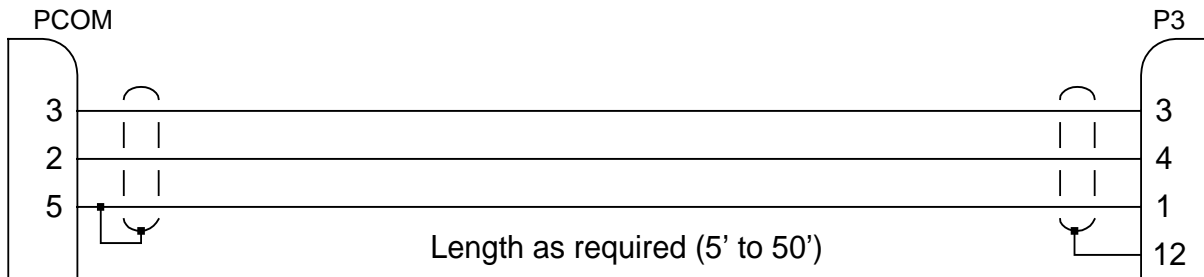

4.4.3 WinVIEWS

(Windows Virtual Interface to the Enhanced Warning System)

WinVIEWS is a software tool developed by Honeywell to communicate with the EGPWS. WinVIEWS provides a detailed status of the software configuration and input signals, which enables quick identification of system configuration, and is utilized for programming the system Configuration Module.

Honeywell
MK XXII EGPWS Installation Manual

To obtain a copy of the WinVIEWS software, contact:

Honeywell	or	Honeywell
Aerospace Electronic Systems		Aerospace Electronic Systems
PO Box 97001		PO Box 97001
Redmond, WA 98073-9701 USA		Redmond, WA 98073-9701 USA
Attn: Order Administration M/S 33		Attn: EGPWS Applications Engineering
Phone: (425) 885-8719		Phone: (425) 885-3711
FAX: (425) 885-8988		FAX: (425) 885-2994
		GPWS Hotline: (800) 813-2099

WinVIEWS can be sent via e-mail when an e-mail address is provided or downloaded from the web (www.egpws.com)

4.4.4 WinVIEWS Operation

1. Connect the PC to the EGPWC using the RS-232 cable as described in section 4.4.2.
2. On the PC, start Windows 3.1, or higher.
3. Start the WinVIEWS.EXE program.
4. Use **F6** to select the Terminal Mode. Various commands are available in this mode. Type "HELP" or "?" for a list of the commands available.

4.5 Configuration Module Programming

The EGPWC reads the aircraft configuration from the Configuration Module, which is installed in the EGPWC connector. The Configuration Module must have the aircraft specific configuration ID string written to it before the EGPWS is operational. The ID string is defined by 15 separate categories listed in Appendix E Table 5.2, Category ID Selection Procedure.

For programming the Configuration Module, the following procedure is used:

1. Verify EGPWC interface to P2 connector (including Configuration Module) and RS-232 interface to PC.
2. Power EGPWC and PC and start WinVIEWS.
3. With WinVIEWS active in the Terminal Mode, configuration sub-mode commands are available for programming purpose. Type "**CFG**" at the Terminal Mode prompt (>). At this point, the CFG> prompt is displayed and the program and EGPWC are ready for entering the program command and data string. Type "**HELP**" or "?" to display a list of the Terminal Mode commands and their description. "**CUW**" is the preface command for entering the ID string.
4. Using the Category ID's as chosen from the Appendix E (refer to completed Table 5.2), create a command string with the following structure:

CUW 0/15 # # # # # # # # # # # # # # # # #

Honeywell
MK XXII EGPWS Installation Manual

- **CUW<space>0** is the command and version number. CUW writes the category ID's defined by version 0 definition (0 is the only version currently available) to the Configuration Module via the EGPWC without a CRC (checksum) value attached (this is generated by the EGPWC when the data is transmitted).
- **/15** indicates the beginning of the data string (/) with 15 being the number of categories to follow.
- **<space><Cat 1 ID#><space><Cat 2 ID #>...<Cat 14 ID#>/** each Cat ID# is the chosen ID for the category from the Appendix E Table 5.2. The ending slash (/) indicates the end of the data string.

Note: If 15 ID's do not follow "/15", the error message "**Invalid Parameter. Not enough ID's. Configuration update failed, please try again.**" will be given. The value entered for each category must be an available ID for the associated category or a similar error message will be given. If the number of categories provided is less than 15 (e.g., "/8 # ... #/" with eight ID's defined), then the remaining categories (9 through 15) will be set to 0.

After completing the data string as defined above, pressing ENTER the cursor will flash waiting for an answer "Y" or "N". Pressing the Y (or y) key confirms the data and sends the data to the EGPWC to write to the Configuration Module.

Note: Using Kermit or a similar terminal emulator pressing ENTER results in a question: "**Confirm this data reflects configuration to be programmed (Y/N)**". Pressing the Y (or y) key confirms the data and sends the data to the EGPWC to write to the Configuration Module.

Following the writing to the Configuration Module the EGPWC is automatically rebooted in order for the new configuration to take affect.

Note: If when the ENTER key is pressed the question response is not given (cursor just moves to the next line), pressing any character key should provide the proper response.

Pressing the N key results in the message "**Command aborted – No configuration module change has been made**". If necessary, revise the data to correct or change as necessary and continue as above. The backspace key can be used to make corrections.

5. Following the successful writing to the Configuration Module (no error messages) and EGPWC reboot, pressing **Control Z (Ctrl-Z)** restarts the WinVIEWS Terminal Mode communication.
6. There are a couple ways to now confirm the Configuration Module programming with the following being the preferred. As above, type "CFG" to restart the Configuration sub-mode. At the CFG> prompt, type "**CMR<Enter>**". Each category and its associated ID is read from the

Honeywell
MK XXII EGPWS Installation Manual

Configuration Module and listed on the PC screen. Alternately, when not in the Configuration sub-mode, the command “**PS<Enter>**” (Present Status) will display EGPWC and configuration data.

7. Configuration Module programming is complete. If the “CFG >” prompt is still present type “**Exit<Enter>**” to exit the Configuration sub-mode.

4.5.1 CUW and CMR Commands

An example CUW command/data string, its definition, and the corresponding CWR list is provided below.

CUW command/data string:

CFG > CUW 0/15 128 3 2 134 128 3 29 1 0 2 0 0 129 0 15/

Above configuration defined:

Category 1 Aircraft/Mode Type:	128	
Category 2 Air Data Type:	3	
Category 3 Position Type:	2	
Category 4 Altitude Callouts Menu:	134	(All Callouts)
Category 5 Audio Menu:	128	(Basic menu)
Category 6 Display Type:	3	
Category 7 Options Select Group #1:	29	(TA&D Alternate pop-up False) (Peaks Mode True) (Obstacle Awareness True) (Bank Angle True) (Weight on Wheels Reversal) (GPS Altitude Ref. MSL)
Category 8 Radio Altitude Type:	1	
Category 9 Navigation Type:	0	
Category 10 Attitude Type:	2	
Category 11 Heading Type:	0	
Category 12 Windshear select Type:	0	
Category 13 Discrete I/O Type:	129	
Category 14 Audio Output Level Type:	0	
Category 15 Autorotation Threshold	15	

CWR list: (based on the above configuration)

CFG > CMR<Enter>

CONFIGURATION MODULE:

Format Version:	0
Category 1 ID:	128
Category 2 ID:	3
Category 3 ID:	2
Category 4 ID:	134
Category 5 ID:	128
Category 6 ID:	3

Honeywell
MK XXII EGPWS Installation Manual

Category 7 ID:	29
Category 8 ID:	1
Category 9 ID:	0
Category 10 ID:	2
Category 11 ID:	0
Category 12 ID:	0
Category 13 ID:	129
Category 14 ID:	0
Category 15 ID:	15
CRC:	527518533

4.5.2 Configuration Module Reprogramming

Reprogramming the EGPWS Configuration Module is accomplished similar to the programming process above. Prior to reprogramming, the desired new configuration should be determined based on the MK XXII Installation Manual (Appendix E), document number 060-4314-225.

For reprogramming the Configuration Module, the following procedure is used:

1. Verify EGPWC interface to P2 connector (including Configuration Module) and RS-232 interface to PC.
2. Power EGPWC and PC and start WinVIEWS.
3. With WinVIEWS active in the Terminal Mode, start the Configuration sub-mode by typing "CFG" at the prompt (>). At this point, either all the ID's can be rewritten using the CUW command as before, or individual categories can be changed as follows:
4. At the *CFG >* prompt use the **CAT** command with the following structure:
 - **CAT<space><category #><space><ID#><space><T or F><Enter>**
 - <category #> is the Appendix E Category to change (example 7)
 - <ID #> is the new ID to change to (example 92)
 - <T or F> is True or False for rebooting the EGPWC. Use "T" if only one category is to be changed and the EGPWC will reboot following <Enter>. Use "F" if another individual ID is to be changed by another CAT operation.

Example: **CFG > CAT 7 92 T<Enter>**

5. After inputting the desired change information, pressing <Enter> will transmit the data to the EGPWC to write to the Configuration Module. If a reboot is commanded (T), then the EGPWC will reboot at the completion of the write process. If a reboot is not commanded (F), then a message "**Writing to configuration module ... Category 7 ID updated successfully.**" is given and the **CFG >** prompt is again displayed. At this point the Configuration Module has been changed, but the change will not be effective until the EGPWC is rebooted. Additional changes can be made with the final change set to command the EGPWC to reboot (or cycle EGPWC power to reboot).
6. Verification of the changes made is the same as before. As above, type "**CFG**" to restart the Configuration sub-mode. At the **CFG >** prompt, type "**CMR<Enter>**". Each category and its

Honeywell
MK XXII EGPWS Installation Manual

associated ID is read from the Configuration Module and listed on the PC display. Alternately, when not in the Configuration sub-mode, the command "**PS<Enter>**" (Present Status) will display the EGPWC and Configuration Module data.

7. Configuration Module reprogramming is complete.

4.6 Regional Terrain Database Loading

4.6.1 Effectivity

The MK XXII EGPWS (965-1590-0XX) are shipped from the factory with the North American Regional Terrain Database installed. Aircraft operating outside of the North American region will have to load one of the other eight Regional Terrain Databases before beginning the ground test. Use (operation) of a MK XXII EGPWS outside of the loaded Regional Terrain Database will result in the Terrain Awareness function being unavailable.

4.6.2 Description

This modification consists of loading the PCMCIA card into the EGPWS either **In The Aircraft** or **On The Bench**. An optional verification procedure is provided.

4.6.3 Approval

This procedure contains no modification information that revises the approved configuration and therefore does not require FAA or other regulatory agency approval.

Honeywell
MK XXII EGPWS Installation Manual

4.6.4 Material – Cost and Availability

The Regional Terrain Database PCMCIA card is available at no charge to Operators that will be operating outside of the North America region. Order part from:

Honeywell
Airlines & Avionics Products
Order Administration M/S 33
PO Box 97001
Redmond, WA 98073-9701
Phone: 425-885-8719
Fax: 425-885-8988

Honeywell Aerospace
Toulouse Office
Centreda, Avenue Didier Daurat
31700 Blagnac, France
Phone: (33) 5-6171-0079
Fax: (33) 5-6130-0497

Vendor Name	Vendor P/N	Description	QTY	UM	Honeywell P/N
Honeywell	424NAM	North America	1	EA	718-1447-XXX
Honeywell	424 SAM	South America	1	EA	718-1448-XXX
Honeywell	424EUR	Europe	1	EA	718-1449-XXX
Honeywell	424EEU	Eastern Europe	1	EA	718-1450-XXX
Honeywell	424AFR	Africa	1	EA	718-1451-XXX
Honeywell	424PAC	Pacific	1	EA	718-1452-XXX
Honeywell	424SPA	South Pacific	1	EA	718-1457-XXX
Honeywell	424MES	Middle East	1	EA	718-1458-XXX

Honeywell
MK XXII EGPWS Installation Manual

4.6.5 Accomplishment Instructions

Load the PCMCIA card data as described in paragraphs 4.6.5 A. or 4.6.5 B. below. Loading time will be approximately 70 minutes.

A. Loading the PCMCIA Card Data with the Computer mounted in the Aircraft.

- (1) Connect the Smart Cable (Honeywell PN 951-0386-001) to the EGPWC J3 connector.
- (2) Ensure that the 28 VDC circuit breaker to the EGPWC is ON and that the **COMPUTER OK** LED on the EGPWC front panel is on.
- (3) Insert the PCMCIA card into the Smart Cable PCMCIA card slot.

NOTE: Precautionary notes on the PCMCIA card, regarding insertion and/or removal while power is applied, should be ignored since the EGPWC automatically handles the application and removal of PCMCIA card power.

- (4) While the loading is in progress, the **IN PROG** LED on the Smart Card remains ON and the **COMPUTER OK** LED on the EGPWC is OFF.
- (5) When loading is complete the **XFER COMP** LED on the Smart Card turns ON.
- (6) Remove the PCMCIA card from the Smart Card slot.
- (7) After approximately 15 seconds the **COMPUTER OK** LED comes ON to indicate that the contents of the PCMCIA card were successfully transferred.
- (8) Remove the Smart Card connector from the EGPWC front panel J3 connector.
- (9) To perform the verification of the Terrain Database version, go to paragraph 4.6.6 below.

B. Loading the PCMCIA Card Data with the Computer removed from aircraft

- (1) Locate a 28 VDC Power Supply with a minimum supply current of 2 amps.
- (2) With the Power Supply turned OFF, connect the Power Supply to the J1 connector of the EGPWC as follows:

J1 connector Pin	Pin Nomenclature
J1-40, J1-60	28 VDC (+)
J1-41, J1-61	28 VDC (-)
J1-42, J1-53	Chassis GND

Honeywell
MK XXII EGPWS Installation Manual

- (3) Connect the Smart Cable (Honeywell PN 951-0386-001) to the EGPWC J3 connector.
- (4) Turn the Power Supply ON and verify the **COMPUTER OK** LED on front of the EGPWC panel is on.
- (5) Insert the PCMCIA card into the Smart Cable PCMCIA card slot.

NOTE: Precautionary notes on the PCMCIA card, regarding insertion and/or removal while power is applied, should be ignored since the EGPWC automatically handles the application and removal of PCMCIA card power.

- (6) While the loading is in progress, the **IN PROG** LED on the Smart Card remains ON and the **COMPUTER OK** LED on the EGPWC remains OFF.
- (7) When loading is complete the **XFER COMP** LED on the Smart Card turns ON.
- (8) Remove the PCMCIA card from the Smart Card slot.
- (9) After approximately 15 seconds the **COMPUTER OK** LED comes ON to indicate that the contents of the PCMCIA card were successfully transferred.
- (10) Remove the Smart Card connector from the EGPWC front panel J3 connector.
- (11) To perform the verification of the Terrain Database version, go to paragraph 4.6.6 below.

4.6.6 Verification of the Terrain Database Version

Since the EGPWC software verifies the PCMCIA card loading process, this verification is to assure the operator/installer that the correct Regional Terrain Database version is installed.

Terrain Database version verification is accomplished with the EGPWS Self Test (ST) function. The ST function may be initiated from the aircraft cockpit with the GPWS Test Switch. **NOTE:** Initiation of the cockpit ST function may vary from one aircraft to another. For example, the ST function may be initiated by pressing the **GPWS (PULL-UP)** light assembly, or by activating a separate ST switch.

The EGPWS ST function has 6 levels that describe the current condition and configuration of the EGPWS, the fault and warning history, and the condition of the various inputs. To help navigate through the various levels, there are 2 cancel functions: **SHORT CANCEL** (press and hold the ST button for more than 0.5 seconds, but less than 2 seconds) and **LONG CANCEL** (press and hold the ST button for more than 2 seconds, but less than 8 seconds). The Short Cancel and Long Cancel functions operate differently, depending upon the ST level. To initiate a ST sequence, or

Honeywell
MK XXII EGPWS Installation Manual

to continue from level-to-level, the ST button must also be 'pressed and held' for more than 0.5 seconds, but less than 2 seconds, which is identical to the Short Cancel function.

Therefore, for simplicity, the phrase "Press ST Button" in the verification procedure means to press and hold the ST button for more than 0.5 seconds, but less than 2 seconds. The procedure guides the operator directly to ST Level 3, "System Configuration", skipping most of ST Level 1 and Level 2.

To verify the Regional Terrain Database that was just loaded into the EGPWC, perform these steps:

NOTE: 'On the Bench', this test requires an audio speaker and a self test button.

- (1) Ensure the EGPWC power is ON
- (2) **Press ST button** to initiate ST Level 1.
- (3) After ST Level 1 message starts, **Press ST button** to cancel Level 1 and start Level 2.
- (4) After ST Level 2 message, "Current Faults", is heard, **Press ST button** to cancel Level 2.
- (5) When the message, "Press to Continue", is heard, **Press ST button** to start ST Level 3.
- (6) Verify the Terrain Database version annunciated in the following sequence:
 - a) "SYSTEM CONFIGURATION"
 - b) "PART NUMBER 965-1590-XXX"
 - c) "MOD STATUS XX"
 - d) "SERIAL NUMBER XXXX"
 - e) "APPLICATION SOFTWARE VERSION XXXXX"
 - f) "TERRAIN DATABASE VERSION XXXX"

The following example of Terrain Database Version annunciation: "424NAM" (for NORTH AMERICA), "424EUR" (for EUROPE), or "424PAC" (for PACIFIC). Other versions will follow the same pattern.

- (7) Other messages that follow the Terrain Database Version can be ignored. When ST Level 3 finishes, the message "Press to Continue" is heard. If the ST button is not pressed again the ST sequence terminates.

NOTE: If power was connected to the EGPWC per steps B1 through B4, perform shut-down per steps (7) and (8) following.

- (8) **Turn Power Supply OFF.**
- (9) Disconnect Power leads from the EGPWC.

END OF TEST

Honeywell
MK XXII EGPWS Installation Manual

SECTION V
CERTIFICATION

Honeywell
MK XXII EGPWS Installation Manual

SECTION V – CERTIFICATION 124

5.1 INTRODUCTION	124
5.2 CERTIFICATION PROCEDURE	124
5.2.2 <i>Equipment Location</i>	124
5.2.3 <i>FAA Requirements</i>	124
5.2.4 <i>Ground Test</i>	124
5.2.5 <i>Flight Manual Revision</i>	124
5.2.6 <i>Flight Test</i>	125
5.2.7 <i>Pilots Guide</i>	125
5.2.8 <i>Failure Modes, Effects, and Safety Analysis</i>	125
5.2.9 <i>Existing STC's</i>	125

SECTION V – CERTIFICATION

5.1 Introduction

This section outlines the procedures required to obtain FAA approval for the MK XXII EGPWS installation.

5.2 Certification Procedure

5.2.1.1 Equipment Compatibility

Careful consideration must be paid to the electrical characteristics of existing equipment or possible additions that will be interfaced to the MK XXII EGPWS, in order to ensure system compatibility. Section III of this manual provides system-planning guidelines, and defines the electrical characteristics of the EGPWS. **The installing agency should contact Honeywell Product Support (800-813-2099), for information regarding the compatibility of equipment not listed in Section III or interface into any airframe not listed in Appendix E Table E 3.1.1.** Normal business hours are 8:00 AM to 5:00 PM Pacific Time, Monday through Friday.

5.2.2 Equipment Location

The EGPWS and associated indicators, annunciators, and switches should be clearly visible and within easy reach of the pilot(s). Refer to Section II of this manual for complete installation information.

5.2.3 FAA Requirements

The installing agency should contact a local FAA Inspector who will determine whether the installation may be approved by Supplemental Type Certificate (STC) or by submitting FAA Form 337 with an applicable STC package.

5.2.4 Ground Test

Honeywell has developed a generic Installation Ground Test Procedure for the MK XXII EGPWS, drawing number 060-4167-167.

5.2.5 Flight Manual Revision

Honeywell has developed a generic Rotorwing Flight Manual Supplement for the MK XXII EGPWS, drawing number 060-4314-009.

Honeywell
MK XXII EGPWS Installation Manual

5.2.6 Flight Test

Honeywell has developed a generic Flight Test procedure for the MK XXII EGPWS, drawing number 060-4314-006. The Flight Test procedure was developed for first of type installations, for these installations all sections of the Flight Test procedure shall be performed.

For follow on installations of the same aircraft type and interface, the flight test is not required. When updating an STC to the current part number it is only necessary to flight test significant new features. The notice of change is available in Honeywell Service Bulletins.

5.2.7 Pilots Guide

Honeywell has developed a Pilot's Guide for the MK XXII EGPWS, drawing number 060-4314-200 that provides a description of the modes and the controls of the EGPWS.

5.2.8 Failure Modes, Effects, and Safety Analysis

Honeywell has developed a Failure Modes, Effects, and Safety Analysis document for the MK XXII EGPWS, drawing number 060-4314-002 that provides an analysis of the failure modes of the EGPWS.

5.2.9 Existing STC's

For more information and a list of existing STC's see the EGPWS web site www.egpws.com

Honeywell
MK XXII EGPWS Installation Manual

Honeywell
MK XXII EGPWS Installation Manual

APPENDIX A
CUSTOMER WORKSHEET

Honeywell
MK XXII EGPWS Installation Manual



MK XXII EGPWS ENHANCED GROUND PROXIMITY WARNING SYSTEM

The purpose for this work sheet is to obtain the necessary aircraft data for determining the specific interface configuration for the MK XXII Enhanced Ground Proximity Warning System (EGPWS). For defined MK XXII EGPWS interface data, refer to Honeywell document No. 060-4314-225, *Installation Manual for the MK XXII*. For product description information, refer to Honeywell document No. 965-1590-601, *Product Specification for the MK XXII Enhanced Ground Proximity Warning System*. Contact Honeywell EGPWS Applications Engineering for assistance.

Aircraft Operator: Contact:	Phone:	Installer: Contact:	Phone:
Aircraft Type (be specific): Model	S/N	N #	Engine Type (model number):

COCKPIT DISPLAYS:

Please provide the following information for intended EGPWS display purposes (include any new displays planned):

SYSTEM	QTY	MANUFACTURER	MODEL NO.	PART NO.	SOFTWARE NO.
EFIS Symbol Generator					
EFIS Display					
EFIS Display Control Panel					
Multifunction Display (MFD)					
Weather Radar Indicator					
Weather Radar R/T					
Weather Radar Controller					
Other (specify)					

Notes: _____



MK XXII EGPWS

ENHANCED GROUND PROXIMITY WARNING SYSTEM

AIRCRAFT SYSTEMS INFORMATION: Please provide the manufacturer, model number, part number, software part number, model number, part number, software part number, quantity per aircraft, and output data information for:

SYSTEM	MFGR.	MODEL NO.	PART NO.	SW PART NO.	QTY	OUTPUT DATA FORMAT – NOTES (ARINC 429, 547, 552, 575, DC, synchro, potentiometer, discrete, etc. Identify available ARINC 429 labels)
Air Data Computers						
GPS *						
Radio Altimeters						
ILS Receivers						
AHRS / IRU / INU						
VG						
DG						
Engine Torque						

* GPS Altitude Reference: WGS-84 MSL

Use "N/A" if Not Applicable

MK XXII EGPWS ENHANCED GROUND PROXIMITY WARNING SYSTEM

DISCRETE INPUTS:

Please check applicable boxes for both up and down positions.

PARAMETER	GND	OPEN	+28 VDC
DH	<input type="checkbox"/> > _____ ° <input type="checkbox"/> < _____ °	<input type="checkbox"/>	<input type="checkbox"/> > _____ ° <input type="checkbox"/> < _____ °
WOW		<input type="checkbox"/>	
Landing Gear Down	<input type="checkbox"/>	<input type="checkbox"/>	<input type="checkbox"/>
Landing Gear Up	<input type="checkbox"/>	<input type="checkbox"/>	<input type="checkbox"/>

Notes: _____

Listed below are typical parameters from each system, which are required to implement the EGPWS functions. Note that this list is a typical example. Actual source systems may vary depending on aircraft configuration and selected options.

SYSTEM	PARAMETERS
RADIO ALTIMETER	radio altitude, decision height
ADC	barometric altitude, corrected baro altitude, baro rate, computed airspeed, static air temperature or total air temperature
IRS / AHRS	magnetic heading, vertical velocity, pitch, roll
ILS / NAV receiver	glideslope deviation / flag , localizer deviation / flag
FMS / GPS	altitude, latitude, longitude, ground speed, true track, true heading, mag variation, Nav mode, horizontal figure of merit, horizontal integrity limit, vertical figure of merit
Engine 1 and 2 or FADEC	Torque
Display	Range

GENERIC MODEL INFORMATION

Manufacturer: _____

Model: _____
(be specific)

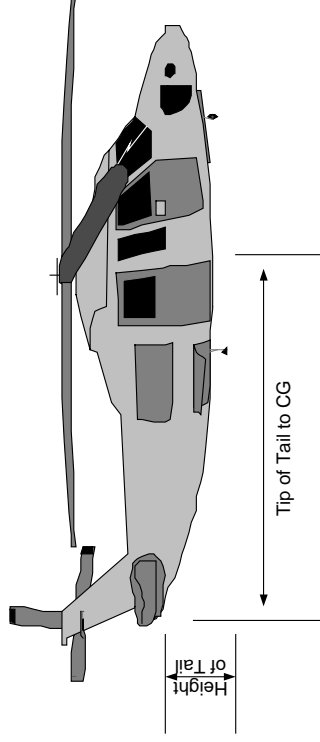

Aircraft Tail Geometry:

- Height of Nominal CG above ground _____
- Distance from CG to Tail (Lowest point of tail or skid) _____
- Distance from CG to center of Tail Rotor _____
- Distance from lowest point of tail or tail-skid to ground _____
- Distance from tail rotor blade (lowest point) to ground _____

Rotational Frequencies:

Main Rotor RPM _____ **No. Of Blades (Main Rotor)** _____

MK XXII EGPWS ENHANCED GROUND PROXIMITY WARNING SYSTEM

SYSTEM	Number of Engines	DATA FORMAT	Signal Scale Factor	NOTES
Engine Torque		(ARINC 429, RS 422, RS 232, synchro, DC, AC	In % Torque	

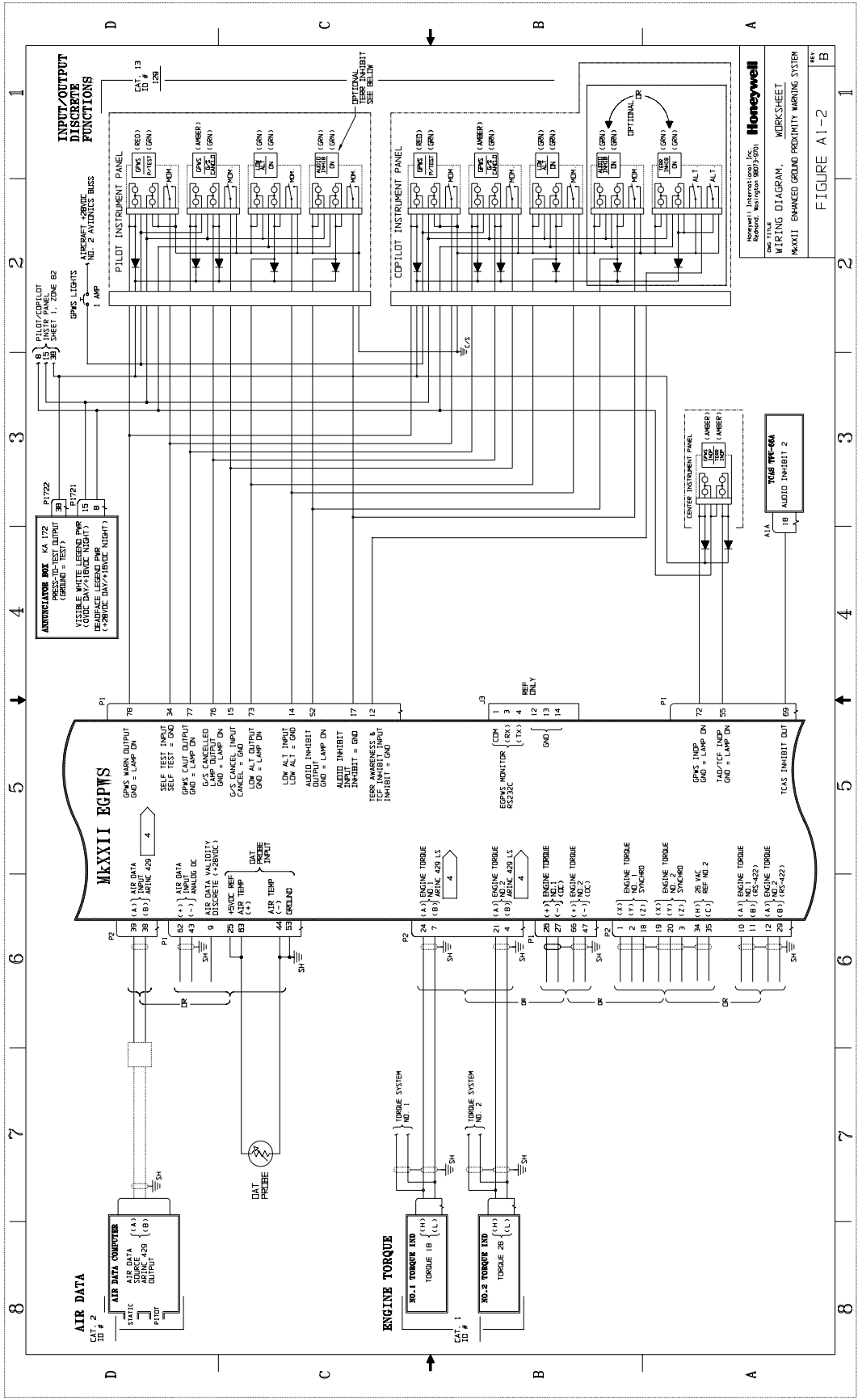

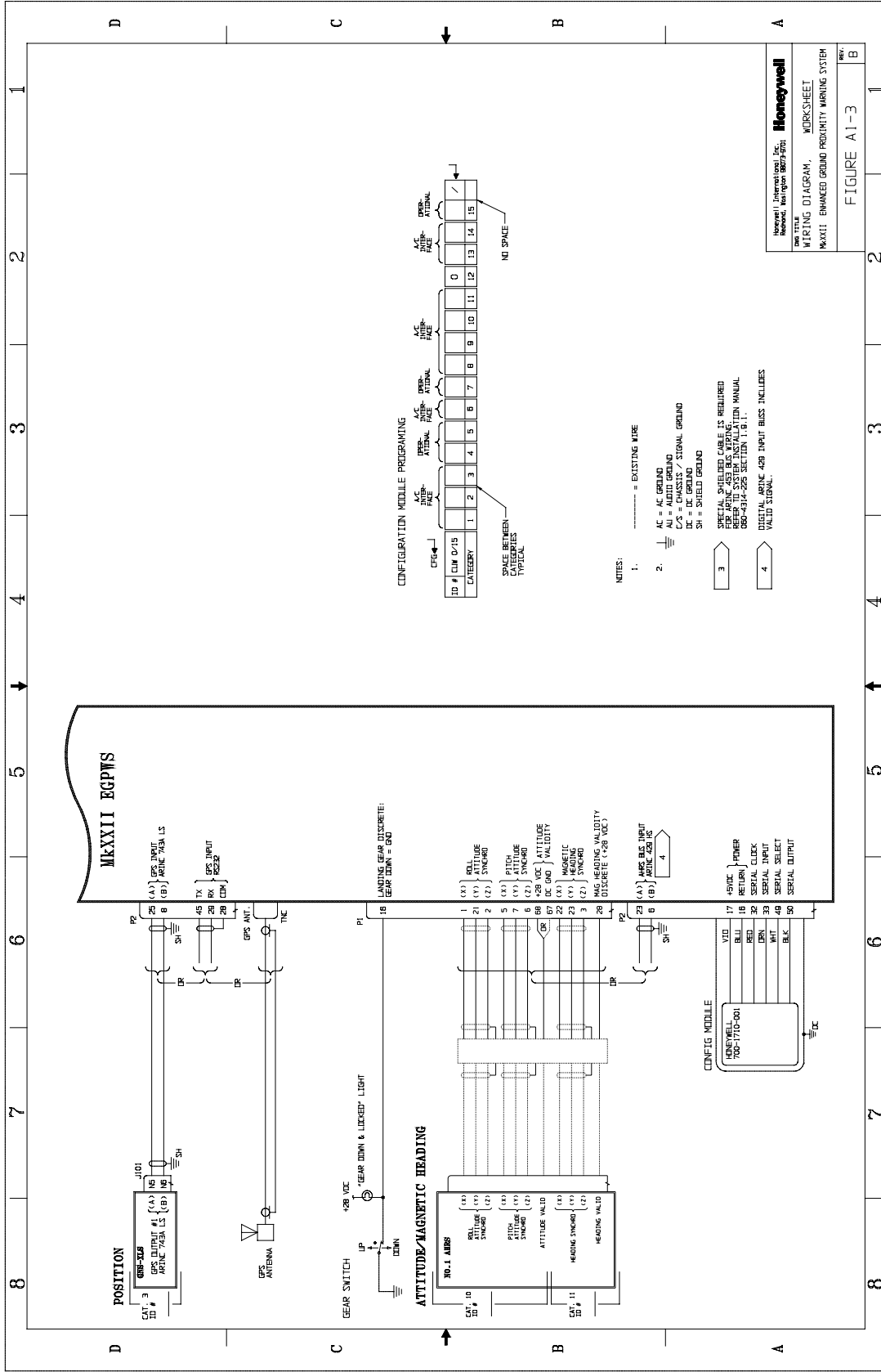

Honeywell Electronic Systems International Inc.
 Honeywell Navigation Systems 5807-5701

DWG TITLE WORKSHEET
 WIRING DIAGRAM, MAXXII ENHANCED GROUND PROXIMITY WARNING SYSTEM

FIGURE A1-3

APPENDIX B
SAMPLE WIRING DIAGRAMS

Honeywell
MK XXII EGPWS Installation Manual

Honeywell
MK XXII EGPWS Installation Manual

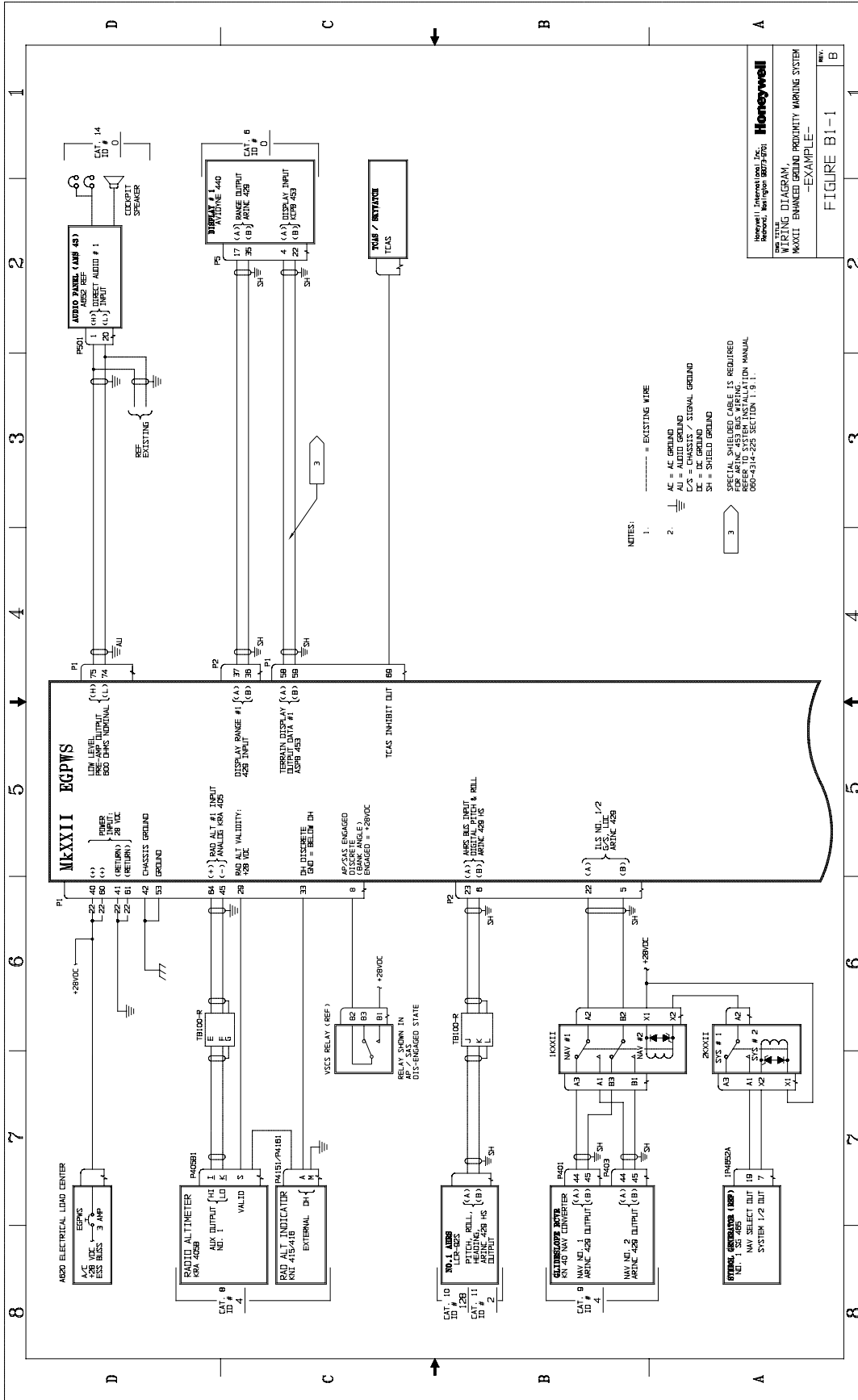

Honeywell International Inc.
10000
MKXXII EGPWS
WIRING DIAGRAM,
MKXXII ENHANCED GROUND PROBING SYSTEM
-EXAMPLE-
FIGURE B1-1
REV. B

Honeywell
MK XXII EGPWS Installation Manual

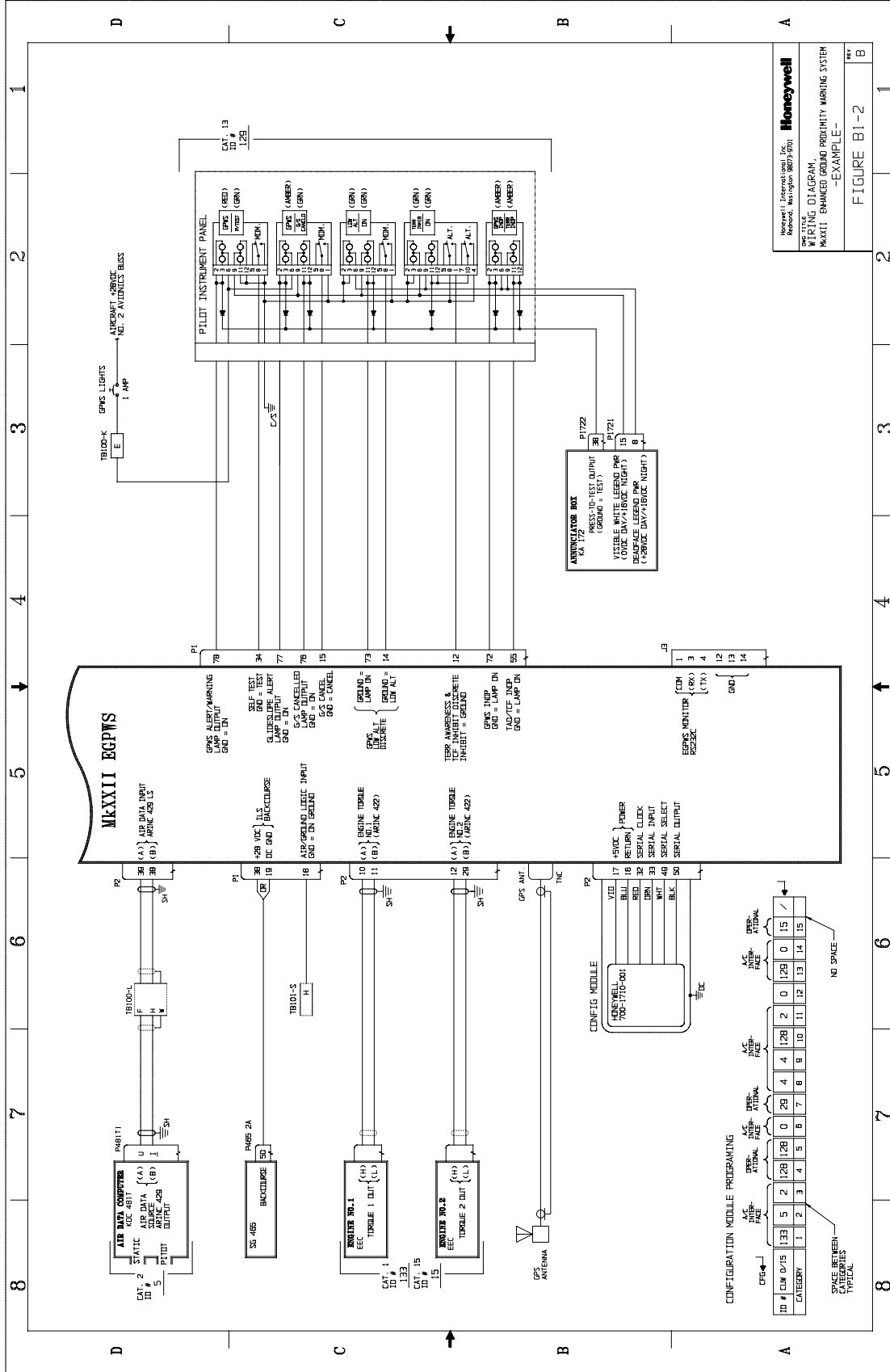

Honeywell International Inc.
7500 Woodloch Forest Drive
Austin, TX 78739-5001

Honeywell

Part No. 1-100-00000-0000
MKXXII ENHANCED GROUND PROXIMITY WARNING SYSTEM
-EXAMPLE-

FIGURE B1-2

APPENDIX C
WinViews OPERATION INSTRUCTIONS

Honeywell
MK XXII EGPWS Installation Manual

APPENDIX C – WinViews Operation Instructions

RS-232 COMMUNICATION WITH THE EGPWS

The EGPWS contains software that allows monitoring of its internal parameters, for testing purposes, without altering its operation. The monitoring of these parameter values enables the operator to quickly determine if the correct signal and scaling is being used by the EGPWS computer. The communication link utilizes the RS-232 Communication Protocol configured as follows:

19200 Baud, No Parity, 8 bits, and 1 stop bit.

The RS-232 interface with the EGPWS is accomplished via the J3 test connector on the front of the EGPWS. The connection between a PC (with a standard DB9 serial port connector) and the EGPWS RS-232 interface is defined as follows: (Please note that the EGPWS will activate its RS-232 port only when it receives the command **CONTROL Z** after power is applied to the EGPWS. The CONTROL Z command is automatically sent by WinVIEWS)

	RS-232 Receive	RS-232 Transmit	RS-232 Ground
EGPWS Front Connector	Pin 3	Pin 4	Pin 1
Standard DB9 Connector (for a PC)*	Pin 3	Pin 2	Pin 5

***NOTE:** Some PC Comm Ports have Pins 2 & 3 reversed from what is described above.

The mating connector for the EGPWS J3 test connector is a male (pins) 15 pin double density D-subminiature type, Positronics Industries (kit) part number ODD15M1OYOZ or the following individual parts:

Nomenclature (AMP)	Amp Part Number	Military Part Number
Connector Shell (HDP-22 Crimp Snap In Contact)	748364-1	reference MIL-C-24308
Size 22 DM Crimp Snap In Contacts Pin 0.030	204370-2	M39029/58-360
Backshell (Shielded Cable Clamp Assembly)	745854-5	
Jackscrews, 2 required (4-40 Male Jackscrew Kit)	747784-8	
Grommet Sets	747746-1	

The following tools will work with Positronics, Amp, and Mil Spec Connectors:

Insertion / Extraction Tool	91067-1	M81969/1-04
Hand Crimp Tool		M22520/2-01
Positioner		M22520/2-09

Honeywell
MK XXII Installation Manual

WinVIEWS OPERATION:

Windows Virtual Interface to the Enhanced Warning System

WinVIEWS software is a tool developed by Honeywell to monitor or view values within the EGPWS. The WinVIEWS software provides a monitor function that does not alter the operation of the EGPWS. The monitoring of values assists in the installation testing of the EGPWS by allowing the operator to quickly determine if the correct signal and scaling is being used by the EGPWS. Additionally, WinVIEWS provides a detailed status of the software configuration and input signals which enables quick identification of system anomalies.

WinVIEWS software can be ordered as Honeywell part number **998-2846-500**. A User's Guide to WinVIEWS is available as Honeywell document number **998-2846-600**. The software consists of the WinVIEWS executable file, a help file, and sample command files.

The command file is a simple text file that should include each CVT Item used in this test procedure. A sample command file for this test procedure is found on the following page. The file must be a 'Text Only' type of file, such as those created in the Microsoft Windows Note Pad program. It should have a filename extension of .CMD. Once this file is loaded, WinVIEWS can automatically display the current value of each parameter listed in the file.

Normal Operation for Ground Testing the EGPWS:

- STEP 1** - Connect the PC to the EGPWS via the RS-232 cable as defined above.
- STEP 2** - On the PC, start Windows 3.1, or higher.
- STEP 3** - Start the WinVIEWS program.
- STEP 4** - Under the File Menu select the "Load Command File" option and load the appropriate Command File.
- STEP 5** - Use F6 to select Data Display Mode. Each CVT Item listed in the Command File will be continuously updated at a rate of greater than once per second. The values shown for the CVT Items listed will be the test values.

Honeywell
MK XXII Installation Manual

Command File: MK XXII_GTP.CMD

The format for the WinVIEWS command file is:

1. ASCII Text Only; no spaces
2. A CVT Item as specified in the test procedure
3. Each CVT Item Name is followed by a <return> or <enter>

RawRA1	VF
ARA1Val	V
DHDsc	V
RawBAIt1	VF
RawBaroRt1	VF
RawCAS1	VF
RawSAT1	VF
ILSTuned1	V
GnILSTuned1	V
RawAACGS1	VF
AGS1Val	V
GPSLatitude1	VF
GPSLongitude1	VF
RawGLat1	VF
RawGLng1	VF
RawGAIt1	VF
RawVFOM1	VF
RawHFOM1	VF
RawGGSpd1	VF
RawHil1	VF
RawGTTk1	VF
RawRoll1	VF
RawPitch1	VF
AnAtt1Val	V
RawAACMHD	VF
AACMHDVal	V
WOWDsc	V
LandGrDsc	V
GSCan	V
AudInhDsc	V
M6LwVolDsc	V
GSInh	V
GSInhDsc	V
TAWxRng1	VF
TAWxRng2	VF
TerrDis	V
AnaTerrDis	V
RawTorque1	VF
RawTorque2	VF
TacticalSel	V
TAInop	C
TAInop1	C
TAInop2	C
EngTorque1	VF
EngTorque2	VF
DispRngOut1	V
DispRngOut2	V

Honeywell
MK XXII Installation Manual

APPENDIX D
VENDOR DRAWINGS

Honeywell
MK XXII EGPWS Installation Manual

Honeywell
MK XXII EGPWS Installation Manual

D 1-0 Vendor Contact Information

The vendor contact information provided below is current at the time of publication of this document.

AMP	2800 Fulling Mill Road MS 038-035 Middletown, PA 17507 800 806-0480	
Barry Controls	Burbank, CA 818 843-1000	<u>United Kingdom:</u> Surrey, England 44 (0932) 22-4122
	Brighton, MA 616 787-1555	<u>Germany:</u> Raunheim, Germany 49 (6142) 43077/8/9
EDMO	5505 E. Rutter Ave. Spokane, WA 99212 www.edmo.com 1 800 235-3300	
Electronic Cable Specialists and Electrical Conservation Systems, Inc.	5300 W Franklin Drive Franklin, WI 53132-8642 414 421-5300	
EMTEQ, Inc.	S84 W18693 Enterprise Drive Muskego, WI 53150 (888) 679-6170 (262) 679-6170 (262) 679-6175 Fax e-mail: smatar@emteq.com	
Hollingsead International	Sante Fe Springs, CA 213 921-3436	
IDD Aerospace	Redmond, WA 425 885-4353	
ITT Cannon	Santa Ana, CA 714 557-4700	

Honeywell
MK XXII EGPWS Installation Manual

Korry Electronics	901 Dexter Avenue North Seattle, WA Attention: Airline Sales 206 281-1300 800 257- 8921 For orders and AOG requirements, contact: Sonya Cordova 206 281-3567 email: scordova@korry.com fax: 206 281-3576 SITA: SEAKEXD For engineering inquiries, contact: Bob Jacques Airline Business Manager 206 281-3584 email: bjacques@korry.com fax: 206 273-4128	Tom Howard Airline Business Manager 206 281-1458 email: thoward@korry.com fax: 206 273-4128
Master Specialties Co.	Costa Mesa, CA 714 642-2427	
Optima Wire	1120 Harpeth Industrial Ct. Franklin, TN 37064 615 599-3770	Cathy Harper cathy.h@mindspring.com
PIC Wire & Cable Supply	N63 W22619 Main Street P.O. Box 330 Sussex, WI 53089-0330 414 246-0500 Fax: 414 246-0450	
Sensor Systems, Inc.	8929 Fullbright Avenue Chatsworth, CA 91311 818 341-5366 Fax: 818 341-9059	
StacoSwitch	1139 Baker Street Costa Mesa, CA 92626-4191 www.stacoswitch.com 714-549-3041 Fax: 714-549-0930	Dan Sugg dsugg@stacoswitch.com Also contact EDMO – Avionics Distributor for StacoSwitch
West Coast Specialties	P.O. Box 5010 Preston, WA 98050 425 222-3118 Fax: 425-222-3119 Contact: Bruce Maxwell, (Rep) 206-232-2871 Fax: 206-232-3174	

Honeywell
MK XXII EGPWS Installation Manual

D1-1 EDMO



EDMO Distributors (800)235-3300 – “One Stop Shopping” for the following EGPWS and TAWS support products:

- * MD41-12XX/13XX TAWS ACU's from Mid-Continent Instruments
- * 90-44802-1 PMA'd TAWS ACU from West Coast Specialties
- * Eaton and StacoSwitch EGPWS split switch & annunciator kits
- * Shadin XYZ compass to RS-232/422 Converters
- * Shadin low cost Airdata computers
- * Solid State Altitude Encoders (most models)
- * GAE-1575 GPS Repeater for hangar testing
- * Installation Supplies

Honeywell
MK XXII EGPWS Installation Manual

D1-2 EMTEQ

EMTEQ, Inc. supports all EGPWS/TAWS systems manufactured by Honeywell, Inc. by offering products to help complete your installation. The installation provisions are fully compliant with ARINC specifications and standards.

We have a full understanding of the system requirements for coaxial components, wire harnesses, Switchpanels and mounting accessories.

- ◆ Fully certified and tested RF cable sets for GPS
- ◆ Bulk coax cable (cut to length) and the necessary coax connectors to complete the installation on your own
- ◆ Avionics Trays
- ◆ Switchpanel and mounting hardware
- ◆ ARINC Rack Connectors, Circular Connectors, etc
- ◆ Wire harnesses

GPS - RF Cable Sets

EMTEQ performs the critical electrical testing for GPS cables using a Hewlett Packard 8753D Vector Network Analyzer. The state of the art equipment stores all profiles at the exact time the cables were tested. Comprehensive reports are supplied on all cable assemblies manufactured. Individual assemblies can be matched electrically to an original set of cables when necessary due to the assignment of unique serial numbers on all cable units.

EMTEQ offers a unique option in the marketplace with a choice in two families of RF cable types to meet your specifications and budget. We offer Teflon® (TFLX series) and PE (PFLX series) cables as shown in Table 1 (Table 1.A. Teflon®; Table 1.B. Polyethylene (PE)) . Both types are Skydrol resistant, meet or exceed MIL-C-17, and meet or exceed FAA Flammability requirements. The characteristics of each option give you the choice that fits your requirements. Pricing will differ between the two options, so please call us to discuss your particular project requirements. This phone call may give you the competitive edge required to win your bid. We have this outcome in mind when we offered options to our customers.

For each option, EMTEQ offers connectors to meet the system requirements. Connectors for PFLX and TFLX cable types are listed in Table 2.

Honeywell
MK XXII EGPWS Installation Manual

TABLE 1

Table 1.A. (Teflon® Jacketed RF Coax) (High Temp)

Cable Type	Loss @ 1600 Mhz	O.D.	Bend Radius
P/N	Per 100 ft	(inches)	Minimum
TFLX130-100	21.60 dB	0.130 "	½"
TFLX165-100	17.00 dB	0.161"	1 ¾"
TFLX205-100	13.90 dB	0.195 "	1 ¾"
TFLX295-100	7.60 dB	0.205 "	3.0 "
TFLX480-100	4.75 dB	0.480 "	2.40 "

Table 1.B. (PE – Polyethylene Jacketed RF Coax) (85 C temp)

Cable Type	Loss @ 1600 Mhz	O.D.	Bend Radius
P/N	Per 100 ft	(inches)	Minimum
PFLX195-500	14.00 dB	0.195 "	½"
PFLX240-500	11.00dB	0.242 "	¾"
PFLX340-500	7.59 dB	0.340 "	1"
PFLX500-500	4.27 dB	0.500 "	1 ¼"

Honeywell
MK XXII EGPWS Installation Manual

TABLE 2

Table 2.A.1 Connectors (for TFLX cable series) - GPS

GPS					
Connector Type	Application	Description	TFLX130-100	TFLX165-100	TFLX205-100
TNC male	Antenna	Straight	TMS130-1	TMS165-1	TMS205-1
TNC male	Antenna	Right Angle	TMR130-1	TMR165-1	TMR205-1
TNC female	Disconnects	Bulkhead Straight	TFS130- 2	TFS165-2	TFS205-2
C male	Antenna	Straight	CMS130-1	CMS165-1	CMS205-1
C male	Antenna	Right Angle	CMR130-1	CMR165-1	CMR205-1

GPS				
Connector Type	Application	Description	TFLX295-100	TFLX480-100
TNC male	Antenna	Straight	TMS295-1	TMS488-1
TNC male	Antenna	Right Angle	TMR295-1	TMR488-1
TNC female	Disconnects	Bulkhead Straight	TFS295-2	TFS488-2
C male	Antenna	Straight	CMS295-1	CMS488-1
C male	Antenna	Right Angle	CMR295-1	CMR488-1

Honeywell
MK XXII EGPWS Installation Manual

TABLE 2 (continued)

Table 2.B.1 Connectors (for PFLX cable series) – GPS

		GPS			
Connector Type	Application	Description	PFLX195-500	PFLX240-500	PFLX340-500
TNC male	Antenna	Straight	TMS195-1	TMS240-1	TMS340-1
TNC male	Antenna	Right Angle	TMR195-1	TMR240-1	TMR340-1
TNC female	Disconnects	Bulkhead Straight	TFS195-2	TFS240-2	TFS340-2
C male	Antenna	Straight	CMS195-1	CMS240-1	CMS340-1
C male	Antenna	Right Angle	CMR195-1	CMR240-1	CMR340-1

		GPS	
Connector Type	Application	Description	PFLX500-500
TNC male	Antenna	Straight	TMS500-1
TNC male	Antenna	Right Angle	TMR500-1
TNC female	Disconnects	Bulkhead Straight	TFS500-2
C male	Antenna	Straight	N/A

Honeywell
MK XXII EGPWS Installation Manual

Tool Frame and Die Part Numbers

Cable Type	Mil-Spec P/N	Daniels	Tool Frame	Die Hex
	for Hex Die	P/N for Hex Die		
PFLX195	M22520/5-19	Y142	M22520/5-01 (HX4)	B Hex
PFLX200	M22520/5-19	Y142	M22520/5-01 (HX4)	B Hex
PFLX240	M22520/5-43	Y141	M22520/5-01 (HX4)	A Hex
PFLX340	M22520/5-35	Y137	M22520/5-01 (HX4)	A Hex
PFLX500	M22520/5-21	Y149	M22520/5-01 (HX4)	A Hex
TFLX130	M22520/5-43	Y141	M22520/5-01 (HX4)	A (ARINC) / B Hex
TFLX165	M22520/5-19	Y142	M22520/5-01 (HX4)	B Hex
TFLX205	M22520/5-43	Y141	M22520/5-01 (HX4)	A Hex
TFLX295	M22520/5-35	Y137	M22520/5-01 (HX4)	A Hex
TFLX488	M22520/5-27	Y151	M22520/5-01 (HX4)	A Hex

Honeywell
MK XXII EGPWS Installation Manual

Installation Considerations:

Meeting the specifications when faced with a long cable run could be challenging at some times. Solutions typically are found when combining a Low Loss Cable (large OD) for the majority of the run with a "pig tail" at the box or antenna sides. The "pig tail" cable will have a small OD, and will be very flexible to make the installation in difficult areas easier. Please use the Tables above for additional information. You can also call EMTEQ's knowledgeable staff at the below numbers to help in the configuration and meet your requirements.

EMTEQ, Inc.

S84 W18693 Enterprise Drive

Muskego, WI 53150

(888) 679-6170 Toll Free

(262) 679-6170

Fax: (262) 679-6175

e-mail: smatar@emteq.com

D1-3 Aerospace Optics

Aerospace Optics Inc.

Aerospace Optics Inc. is pleased to support the Honeywell EGPWS/TAWS team with our line of Vivisun LED lighted switches and indicators. We would welcome the opportunity to assist with your installation and address your Honeywell EGPWS/TAWS lighting requirements.

LED Lighting

The Honeywell EGPWS/TAWS systems offer state-of-the-art performance. Accordingly, several recent innovations in LED cockpit lighting have emerged which truly complement the performance of the Honeywell Systems. Traditionally, lighted cockpit switches have used incandescent lamps which are known for the excessive face cap temperatures they generate. The lamps are also subject to high failure rates which degrades sunlight readability and creates reliability concerns. LED lighting resolves each of these limitations as they consume less than half the power of typical incandescent lamps and offer life-of-the-aircraft reliability. However, the use of LED lighting also has a number of additional challenges, which can quickly dilute their utility.

When using LED lighting in the past, sunlight readability and viewing angles were limited and uniform dimming required special pulse width modulation. Additionally, unprotected LEDs were susceptible to damage from transients and voltage spikes from severe electrical environments as defined in RTCA/DO-160D. However, today, with the evolution of LED technology and innovative design techniques, it is possible to take advantage of the efficiencies afforded by LEDs while continuing to meet the lighting and environmental requirements of aircraft design.

The Vivisun LED resolves each of these challenges including DO-160D compliance and standard voltage controlled dimming. LEDs are the lighting source for the future and the ideal compliment to the Honeywell EGPWS/TAWS Systems.

Honeywell
MK XXII EGPWS Installation Manual

Please feel free to contact the Aerospace Optics Technical Sales Team for assistance in addressing the use of LED lighted switches and indicators.

Aerospace Optics Inc.

3201 Sandy Lane

Fort Worth TX, 76016

1-(888)VIVISUN- (848-4786) Toll Free

Fax (817) 654-3405

www.vivisun.com

e-mail : switches@vivisun.com

D1-4 StacoSwitch

StacoSwitch

As a supplier of high reliability switches and indicators for avionics since 1958, StacoSwitch is proud to be integrated with many Honeywell products and divisions. Through our relationship with EDMO Distributors in Spokane, WA, we supply AV17 kits that include all the switches, annunciators, and crimp pins needed to complete the installation of your Honeywell EGPWS (TAWS) system. These kits meet all lighting and color requirements in the shortest and lightest switch and indicator units available on the market. EDMO stocks these kits and can even generate customized legend and color combinations with extremely fast delivery, usually within a couple days.

StacoSwitch can also provide solutions to most switch needs that may arise, such as LED lighting, Night Vision (NVIS) compatibility, EMI/RFI shielding, watertight seals, Digital Dimming Modules that can dim both incandescent and LED lights with consistency, pushbutton guards, and customized-legend switch and indicator assemblies that can be packaged into impressive matrix mounts.

Please check out our full line of products at www.stacoswitch.com. It includes all the detailed information to help answer any questions you may have during an installation and also a link to EDMO.

Contact Information:

Dan Sugg – Vice President of Sales
dsugg@stacoswitch.com

StacoSwitch
1139 Baker Street
Costa Mesa, CA 92626
Phone: (714) 549-3041
Fax: (714) 549-0930
www.stacoswitch.com

Honeywell
MK XXII EGPWS Installation Manual

APPENDIX E
INTERFACE DESCRIPTION DOCUMENT

Honeywell
MK XXII EGPWS Installation Manual

Honeywell
MK XXII EGPWS Installation Manual

INTRODUCTION	166
E 1 Part Number	166
E 2 Purpose	166
E 3 System Overview	166
E 4 ELECTRICAL INTERFACE	167
E 4.1 Introduction	167
E 4.2 Signal Interfaces	167
E 4.2.1 Grounds	167
E 4.2.2 Primary Power Input	167
E 4.2.3 DC Analog Inputs	168
E 4.2.7 AC Analog Inputs	170
E 4.2.9 ARINC 429/575 Digital Serial Bus Inputs	172
E 4.2.9.1 RS-232 / RS-422 Digital Serial Bus Inputs	173
E 4.2.10 Discrete Inputs	174
E 4.2.11 Configuration Module Interface	175
E 4.2.12 GPS Antenna Input	175
E 4.2.13 OAT Voltage Reference Output	176
E 4.2.14 Lamp Driver Outputs	176
E 4.2.16 Audio Outputs	176
E 4.2.17 ARINC Digital Serial Output Busses	177
E 4.2.17.1 ARINC 429 Output Bus	177
E 4.2.17.2 ARINC 453 Output Bus	178
E 4.2.18 Front Panel Test Interface	178
E 4.2.18.1 RS-232 Maintenance Port (serial port 4)	178
E 4.2.18.2 PCMCIA / SmartCable Port	179
E 4.2.18.3 GSE Present Discrete Input	179
E 4.2.19 Front Panel Status Indicators	179
E 5 AIRCRAFT APPLICATION DATA	180
E 5.1 Configuration Types	180
E 5.2 Configuration Selection	180
E 5.3 Configuration Selection Tables	182
E 5.3.1 Category 1, Aircraft / Mode Type Select	183
E 5.3.2 Category 2, Air Data Input Select	189
E 5.3.3 Category 3, Position Input Select	195
E 5.3.4 Category 4, Altitude Callouts	199
E 5.3.5 Category 5, Audio Menu Select	201
E 5.3.6 Category 6, Terrain Display Select	202
E 5.3.7 Category 7, Options 1 Select	231
E 5.3.8 Category 8, Radio Altitude Input Select	233
E 5.3.9 Category 9, Navigation Input Select	236
E 5.3.10 Category 10, Attitude Input Select	238
E 5.3.11 Category 11, Heading Input Select	240
E 5.3.12 Category 12, Windshear Input Select	241
E 5.3.13 Category 13, Input / Output Discrete Type Select	242
E 5.3.14 Category 14, Audio Output Level	245
E 5.3.15 Category 15, Autorotation Threshold	246
E 6 CONNECTOR INTERFACE	247
E 6.1 Pinout for Front Connectors sorted by pin number	247
E 7 DEFINITIONS	252

Honeywell
MK XXII EGPWS Installation Manual

INTRODUCTION

E 1 PART NUMBER

This document is the Interface Description for the MKXXXII Helicopter Enhanced Ground Proximity Warning System (EGPWS) part number 965-1590-0XX.

The MK XXII EGPWC 10 digit part number will identify the configuration of the EGPWC as follows:

- 965-1590-XXX (example 965-1590-010)
- XXX = Application Software (including Configuration Software)

The Terrain Database (including the Envelope Modulation Database) Version is not identified in the 10-digit part number but with a separate identifier on the nameplate.

All modification changes not affecting form, fit or function will be identified via “mod dots”.

The digits identifying the Application software will match the respective version number of the Application software.

E 2 PURPOSE

This Appendix describes all of the system external interfaces for the MK XXII Enhanced Ground Proximity Warning System (EGPWS).

E 3 SYSTEM OVERVIEW

For more information please refer to the EGPWS Product Specification document 965-1590-601.

Honeywell
MK XXII EGPWS Installation Manual

E 4 ELECTRICAL INTERFACE

E 4.1 INTRODUCTION

The MK XXII EGPWS provides electrical interfaces for aircraft systems and to support maintenance functions. The interfaces are made via the front panel aircraft interface connectors, front panel maintenance/test port and front panel LED's. A TNC coaxial connector is located on the front panel for internal GPS receivers in the 965-1590-0XX MK XXII EGPWC. The following sections describe the types of electrical interfaces provided in the EGPWC. See Section E 5 for the specific interface configuration capabilities of the MK XXII EGPWS.

E 4.2 SIGNAL INTERFACES

This section identifies and describes the number and characteristics of each interface type provided in the front aircraft interface connectors. The aircraft interface connectors are defined as P1 (78 pins) and P2 (50 pins). Section E 6 identifies the connector pin assignments. The signal mnemonic for each signal in Section E 6 is included in the following sections. All synchro inputs are brought in as three or five wire devices. No two wire absolute AC signals are available. All analog inputs provide broken wire detection on all input signal legs. Unless otherwise stated, the "Maximum reverse fault current" is defined as the current resulting from an internal component failure, with the input signal at zero volts.

E 4.2.1 GROUNDS

CHASSIS GROUND

Used for redundant metal connection. This pin is internally connected to DC Ground (see section 0).

Pin Assignment (Signal Mnemonic):	J1-42, J1-53	(GND)
-----------------------------------	--------------	-------

DC GROUND

For discrete inputs and lamp driver outputs. These pins are also internally connected to Chassis Ground (see section 0).

Pin Assignment (Signal Mnemonic):	J1-41, J1-61	(PWR_L)
(same as +28 VDC Return)		

NOTE: All analog signals are differential input.

E 4.2.2 PRIMARY POWER INPUT

Nominal Input	28 VDC
Normal Voltage Range	22.0 to 30.3 VDC
Normal Surge Voltage Range	15 – 40VDC (30 msec)
Abnormal Voltage Range	20.5 to 32.2 VDC
Abnormal Surge Voltage Range	37.8 VDC (1sec); 46.3 VDC (100 msec)
Normal Frequency Range	not applicable
Frequency Transients	not applicable
Power Requirements	9 Watts - No Warnings +7 Watts with warning voice over 8 Ω speaker +3 Watts with Internal GPS (includes antenna power) ¹ +49 Watts (typical) with heater blanket on ²
Recommended Power Control Device	3 Amp delayed action circuit breaker.
Pin Assignment (Signal Mnemonic):	
+28 VDC Input	J1-40, J1-60 (PWR_H ³)
+28 VDC Return	J1-41, J1-61 (PWR_L ³)

¹Based on the Honeywell GPS Pexpress card specification and applies to 965-1590-0XX only.

²The heater blanket turns on at temperatures $\leq -23^{\circ}$ C and turns off at temperatures $\geq -20^{\circ}$ C.

Honeywell
MK XXII EGPWS Installation Manual

³Note that this is not a floating input. +28 VDC must be applied to both PWR_H and +28 VDC Return to both PWR_L inputs.

E 4.2.3 DC ANALOG INPUTS

Unless otherwise specified, Input Signal accuracy is 1% linearity +0.1% full scale offset.

E 4.2.3.1 RADIO ALTITUDE

Quantity	1	
Input Impedance, each leg	> 83 K Ω	
Maximum Reverse Fault Current	< 200 μ amps	
Signal Range	0 to 2500 feet	
Input Voltage Range (V_{RA})	$37.7V \geq V_{RA} \geq -2.5V$	
Conversion Range (V_c)	$29.7V \geq V_c \geq -0.4V$	
Input Filter	0.1 Second Low Pass, \pm 10%	
Broken Wire Detect	Input will be biased to less than -50 feet	
Pin Assignment (Signal Mnemonic):		
Signal (+)	J1-64	(RALT_H)
Return (-)	J1-45	(RALT_L)

E 4.2.3.2 LOW LEVEL GLIDESLOPE

Quantity	1	
Input Impedance, each leg	> 2.5 M Ω	
Reverse Fault Current	< 6.2 μ amps	
Signal Range	\pm 12 Dots	
Input Voltage Range	\pm 0.9VDC	
Input Filter	0.1 Second Low Pass, \pm 10%	
Input Type	Differential	
Common Mode Voltage Range (V_{CM})	$11V \geq V_{CM} \geq -2V$	
Broken Wire Detect	Input will be biased less than -15 dots	
Pin Assignment (Signal Mnemonic):		
+Up, Below Beam, Fly Up	J1-65	(GSDEV_H)
+Down, Above Beam, Fly Down	J1-46	(GSDEV_L)

E 4.2.3.3 LOCALIZER DEVIATION OR LOW LEVEL GLIDESLOPE VALIDITY

This input can be configured as either a low level glideslope valid, or as a localizer deviation input. Installations that only have the low level validity signal for glideslope can not activate the analog localizer input. See section 5.3.9 for more information.

Quantity	1	
Input Impedance, each leg	> 2.5 M Ω	
Reverse Fault Current	< 6.2 μ A	
Input Filter	0.1 Second Low Pass, \pm 10%	
Input Type	Differential	
Common Mode Voltage Range (V_{CM})	$11V \geq V_{CM} \geq -2V$	
Pin Assignment (Signal Mnemonic):		
+	J1-30	(GS_VAL_H)
-	J1-10	(GS_VAL_L)

Honeywell
MK XXII EGPWS Installation Manual

When used as a validity input:
 Active Voltage Range (Logic True) +160 to +840 mVDC
 Inactive Voltage Range (Logic False) 0 to 50 mVDC
 Broken Wire Detect Input will be biased less than -1 VDC

When used as a localizer input:
 Signal Range ±12 Dots
 Input Voltage Range ±0.9VDC
 Broken Wire Detect Input will be biased less than -15 dots

E 4.2.4 BAROMETRIC ALTITUDE

Quantity 1
 Input Impedance, each leg > 83 KΩ
 Reverse Fault Current < 200 μamps
 Input Voltage Range -0.18VDC to +15VDC
 Input Filter 0.1 Second Low Pass, ± 10%
 Input Type Differential
 Broken Wire Detect Input will be biased less than -3000 feet
 Pin Assignment (Signal Mnemonic):
 Signal (+) J1-62 (ALT_H)
 Return (-) J1-43 (ALT_L)

E 4.2.5 OUTSIDE AIR TEMPERATURE

Quantity 1
 Input Impedance, each leg > 100 KΩ
 Reverse Fault Current < 200 μamps
 Input Voltage Range +0.3 VDC to +0.6VDC
 Input Filter 0.1 Second Low Pass, ± 10%
 Input Type Differential
 Broken Wire Detect Input will be biased less than -80° C
 Pin Assignment (Signal Mnemonic):
 Signal (+) J1-63 (OAT_H)
 Return (-) J1-44 (OAT_L)

NOTE: For temperature probe voltage reference see section 0.

E 4.2.6 CONFIGURATION DEFINED DC INPUTS

Quantity 2
 Input Impedance, each leg > 83 KΩ
 Reverse Fault Current < 200 μamps
 Input Voltage Range ±5 VDC
 Input Filter 0.1 Second Low Pass, ± 10%
 Input Type Differential
 Broken Wire Detect Input will be biased less than -6 VDC
 Pin Assignment (Signal Mnemonic):
 #1 Signal (+) J1-26 (TORQUE_1H)
 #1 Return (-) J1-27 (TORQUE_1L)
 #2 Signal (+) J1-66 (TORQUE_2H)
 #2 Return (-) J1-47 (TORQUE_2L)

Honeywell
MK XXII EGPWS Installation Manual

E 4.2.7 AC ANALOG INPUTS

Unless otherwise specified, Input Signal accuracy is 1% linearity + 0.1% full scale offset

E 4.2.7.1 SYNCHRO ROLL ATTITUDE

Quantity	1	
Input Impedance: X leg	> 140 K Ω	
Input Impedance: Y leg	> 140 K Ω	
Input Impedance: Z leg	> 140 K Ω	
Maximum Reverse Fault Current	< 200 μ amps	
Input Voltage Range	± 11.8 VAC _{RMS} $\pm 20\%$ (leg to leg)	
Synchro Angle Range	± 80 deg	
Reference Voltages	Not Required	
Accuracy	2.5% linearity + 0.1% full scale offset	
Pin Assignment (Signal Mnemonic):		
X leg	J1-1	(SYN_1X)
Y leg	J1-21	(SYN_1Y)
Z leg	J1-2	(SYN_1Z)

E 4.2.7.2 SYNCHRO MAGNETIC HEADING

Quantity	1	
Input Impedance: X leg	> 140 K Ω	
Input Impedance: Y leg	> 140 K Ω	
Input Impedance: Z leg	> 140 K Ω	
Maximum Reverse Fault Current	< 200 μ amps	
Input Voltage Range	± 11.8 VAC _{RMS} $\pm 20\%$ (leg to leg)	
Reference Voltages	± 26 VAC _{RMS} $\pm 20\%$ (see 4.2.4.4)	
Accuracy	2.5% linearity + 0.1% full scale offset	
Pin Assignment (Signal Mnemonic):		
X leg	J1-22	(SYN_2X)
Y leg	J1-23	(SYN_2Y)
Z leg	J1-3	(SYN_2Z)

Honeywell
MK XXII EGPWS Installation Manual

E 4.2.7.3 CONFIGURATION DEFINED SYNCHRO INPUTS

Quantity	3	
Input Impedance: X leg	> 140 K Ω	
Input Impedance: Y leg	> 140 K Ω	
Input Impedance: Z leg	> 140 K Ω	
Maximum Reverse Fault Current	< 200 μ amps	
Input Voltage Range	$\pm 11.8 \text{ VAC}_{\text{RMS}} \pm 20\%$ (leg to leg)	
Reference Voltages	$\pm 26 \text{ VAC}_{\text{RMS}} \pm 20\%$	
Accuracy	2.5% linearity + 0.1% full scale offset	
Pin Assignment (Signal Mnemonic):		
#1 X leg	J1-5	(SYN_3X)
#1 Y leg	J1-7	(SYN_3Y)
#1 Z leg	J1-6	(SYN_3Z)
#2 X leg	J2-1	(SYN_4X)
#2 Y leg	J2-2	(SYN_4Y)
#2 Z leg	J2-18	(SYN_4Z)
#3 X leg	J2-19	(SYN_5X)
#3 Y leg	J2-20	(SYN_5Y)
#3 Z leg	J2-3	(SYN_5Z)

E 4.2.8 SIGNAL TIMING REFERENCE INPUTS

These inputs accept 400 Hz AC signals, and detect the “zero crossings” of these signals. These zero crossings are used to time the conversion and input of AC signals. Absolute voltage level of these signals is not measured, but it must be within the range specified below. Voltage below the specified minimum value may result in intermittent or “jittery” zero cross detection.

Timing reference signals are required for input of most AC devices (not required for roll). These references can be brought into the appropriate timing reference input, or the system can be configured to derive a reference from the signal. Timing reference signals are specified for synchro inputs requiring a range greater than ± 80 degrees. Inputs requiring less (i.e., Roll Attitude) are configured to derive a reference from the synchro input signal and do not require a separate reference voltage input.

Quantity	2	
Input Impedance	> 140K Ω each line to signal ground	
Maximum Reverse Fault Current	< 120 μ amps	
A/C Input Signal Frequency Range	400 Hz, $\pm 10\%$	
Maximum Input Voltage Swing (differential)	50V between input legs	
Maximum Input Voltage Swing (ref. to Gnd)	50V from any leg to signal ground	
Input Hardware Filtering	None	
Minimum Input Voltage	$\pm 0.5 \text{ VAC}$	
Pin Assignment (Signal Mnemonic):		
26VAC Reference #1 H	J1-4	(26REF_1H)
26VAC Reference #1 C	J1-24	(26REF_1L)
26VAC Reference #2 H	J2-34	(26REF_2H)
26VAC Reference #2 C	J2-35	(26REF_2L)

Honeywell
MK XXII EGPWS Installation Manual

E 4.2.9 ARINC 429/575 DIGITAL SERIAL BUS INPUTS

Quantity	8
Format	DITS, ARINC 429/575 Low or high speed ¹
Low Speed Data Rate	12.0 KBPS to 14.5 KBPS
High Speed Data Rate	100 KBPS \pm 1%
Direction of Information Flow	Type 'A' broadcast for ARINC 429/575
Word/Frame Structure	Type 'B' 32 bit words consisting of 8 bits label and 24 bits data/status
Data definition	Refer to Section 6 of this document
Pin Assignment (Signal Mnemonic):	
Receive #1 A leg	J2-37 (429/422RX_1A)
Receive #1 B leg	J2-36 (429/422RX_1B)
Receive #2 A leg	J2-39 (429RX_2A)
Receive #2 B leg	J2-38 (429RX_2B)
Receive #3 A leg	J2-41 (429RX_3A)
Receive #3 B leg	J2-40 (429RX_3B)
Receive #4 A leg	J2-25 (429RX_4A)
Receive #4 B leg	J2-8 (429RX_4B)
Receive #5 A leg	J2-21 (429RX_5A)
Receive #5 B leg	J2-4 (429RX_5B)
Receive #6 A leg	J2-22 (429RX_6A)
Receive #6 B leg	J2-5 (429RX_6B)
Receive #7 A leg	J2-23 (429RX_7A)
Receive #7 B leg	J2-6 (429RX_7B)
Receive #8 A leg	J2-24 (429RX_8A)
Receive #8 B leg	J2-7 (429RX_8B)

SSM/SDI Definition: Refer to Section 6 of this document

¹ The bus speed is defined in the configuration selection, see Section 5 for details.

Honeywell
MK XXII EGPWS Installation Manual

E 4.2.9.1 RS-232 / RS-422 DIGITAL SERIAL BUS INPUTS

Two full duplex RS-232 / RS-422 buses and a third RS-422 receiver are provided at the aircraft interface connectors. The RS-422 transceivers are electrically multiplexed with the RS-232 transceivers, and are selected through the configuration process. The third RS-422 receiver is electrically multiplexed with the ARINC 429 channel 1 receiver. The maintenance RS-232 bus is described in section 0. The specific characteristics (data rate, parity, data bits, stop bits) is defined in the configuration selection, see Section 5 and 6 for details. RS-422 cable termination will not be required for typical applications, see TIA/EIA-422-B Annex A.

The RS-232 bus meets the characteristics specified in RS232C and supports the following characteristics:

Data Rate	1200, 2400, 4800, 9600, 19200 or 38400 bits/Sec
Parity	None, Odd or Even
Data bits	7 or 8
Stop bits	1 or 2
Maximum Recommended Cable Length	15 meters
Data definition	Refer to Section 6 of this document

The RS-422 bus meets the characteristics of TIA/EIA-422-B and supports the following characteristics:

Data Rate	1200, 2400, 4800, 9600, 12000, 19200 or 38400 bits/Sec
Maximum Transceivers on Bus	20
Receiver Input Impedance	12 K Ω
Word/Frame Structure	Refer to Section 6 of this document
Data definition	Refer to Section 6 of this document

E 4.2.9.2 GPS RS-232 DIGITAL SERIAL BUS (SERIAL PORT 3)

One port is provided for use with external or internal RS-232 GPS interfaces. This port is common with the GPS RS-422 port described in Section 0 and can only function as a RS-232 interface or a RS-422 interface but not both.

Pin Assignment (Signal Mnemonic):

Transmit	J2-45	(GPS_TXA)
Receive	J2-29	(GPS_RXA)
Common	J2-28	(GND)

NOTE: If an internal GPS configuration is used (965-1186-0XX, 965-1216-0XX or 965-1590-0XX) then the receive input will be non-functional.

E 4.2.9.3 GPS RS-422 DIGITAL SERIAL BUS (SERIAL PORT 3)

One port is provided for use with external GPS interfaces. This port is common with the GPS RS-232 port described in Section 0 and can only function as a RS-232 interface or a RS-422 interface but not both.

Pin Assignment (Signal Mnemonic):

Transmit A leg	J2-45	(GPS_TXA)
Transmit B leg	J2-46	(GPS_TXB)
Receive A leg	J2-29	(GPS_RXA)
Receive B leg	J2-12	(GPS_RXB)

NOTE: If an internal GPS configuration is used (965-1186-0XX, 965-1216-0XX or 965-1590-0XX) then the receive input will be non-functional.

Honeywell
MK XXII EGPWS Installation Manual

E 4.2.9.4 AIR DATA RS-232 DIGITAL SERIAL BUS (SERIAL PORT 2)

One port is provided for use with Air Data computer or Static Pressure Sensor interfaces. This port is common with the Air Data RS-422 port described in Section 0 and can only function as a RS-232 interface or a RS-422 interface but not both.

Pin Assignment (Signal Mnemonic):

Transmit	J2-27	(ADC_TXA)
Receive	J2-11	(ADC_RXA)
Common	J2-28	(GND)

E 4.2.9.5 AIR DATA RS-422 DIGITAL SERIAL BUS (SERIAL PORT 2)

One port is provided for use with Air Data computer or Static Pressure Sensor interfaces. This port is common with the Air Data RS-232 port described in Section 0 and can only function as a RS-232 interface or a RS-422 interface but not both.

Pin Assignment (Signal Mnemonic):

Transmit A leg	J2-27	(ADC_TXA)
Transmit B leg	J2-44	(ADC_TXB)
Receive A leg	J2-11	(ADC_RXA)
Receive B leg	J2-10	(ADC_RXB)

E 4.2.9.6 SCI RANGE RS-422 DIGITAL SERIAL BUS (SERIAL PORT 1)

One port is provided for use with the SCI range bus interfaces. This port is common with the ARINC 429 channel 1 port described in Section 0 and can only function as a RS-422 interface or an ARINC 429 interface but not both.

Pin Assignment (Signal Mnemonic):

Recieve A leg	J2-37	(429/422RX_1A)
Recieve B leg	J2-36	(429/422RX_1B)

E 4.2.10 DISCRETE INPUTS

Discrete signals are intended for remote switching through the aircraft, and are therefore subject to being connected to other signals, and are also subject to transient voltage conditions. For these reasons, the following rules apply to each input, unless otherwise stated.

Each input is capable of withstanding voltage transients of ± 600 VDC for 10 μ s, without damage. The +28 VDC discretes are internally biased via a pull down resistor, and are externally pulled up to +28VDC when active. The characteristics of each +28 VDC discrete input are as follows:

+28 VDC Discrete Characteristics

Quantity	13
Active Voltage Range (Logic True)	> +17 VDC
Inactive Voltage Range (Logic False)	< +4.4 VDC
Diode Isolation	None
Input Impedance	> 95 K Ω
Maximum Fault Current	< 60 μ A
Pin Assignment (Signal Mnemonic):	See specific discrete in Category 13 (28V_DISC_xx)

Honeywell
MK XXII EGPWS Installation Manual

The Ground discrettes are internally biased via a pull up resistor, and are externally pulled down to ground when active. The characteristics of each Ground discrete input are as follows:

Ground Discrete Characteristics

Quantity	15
Active Voltage Range (Logic True)	< +3 VDC
Inactive Voltage Range (Logic False)	> 100 K Ω (to ground) or > +3.5 VDC
Diode Isolation	Each input is diode isolated to prevent current sinking
Input Impedance	> 10 K Ω
Maximum Fault Current	< 100 μ A (at +28 VDC input)
Pin Assignment (Signal Mnemonic):	See specific discrete in Category 13 (GND_DISC_xx)

E 4.2.11 CONFIGURATION MODULE INTERFACE

System configuration is defined via a Configuration Module, which resides in the MKIV/VI/VIII/XXII EGPWS aircraft wiring harness backshell. The EGPWS Configuration Module contains the aircraft interface and functionality definitions specific to the installed aircraft. Refer to Section 5 for interface and functional definitions by category.

Electrical Characteristics	Refer to the EGPWS Configuration Module specification	
Data definition	Refer to the EGPWS Configuration Module specification	
Pin Assignment (Signal Mnemonic):		
Clock	J2-32 (RED)	(SPICLK)
Master Data Out	J2-50 (BLK)	(SPIMOSI)
Master Data In	J2-33 (ORN)	(SPIMISO)
Configuration Module Select	J2-49 (WHT)	(SPISEL_CM#)
Configuration Module +5VDC	J2-17 (VIO)	(SC_PWR)
Configuration Module +5VDC Return	J2-16 (BLU)	(GND)

Output to Config Module	Logic Low (nominal)	Logic High (nominal)
	EMK4/6/8/22	EMK4/6/8/22
Clock Out	0 V	5 V
Master Data Out	0 V	5 V
Config Module Select	0 V	5 V

INTERFACE OF EGPWS OUTPUTS TO CONFIGURATION MODULE

E 4.2.12 GPS ANTENNA INPUT

A GPS input connector is available on the front of the MK VI EGPWS (965-1186-0XX only), MK VIII EGPWS (965-1216-0XX only), MK XXII EGPWS (965-1590-0XX only), and MK IV EGPWS (965-1686-0XX only).

Quantity	1
Cable Length/Allowed Signal Loss	Not more than 8 dB, at 1575.42 MHz, for cable and connector loss from antenna to unit.
Connector Type	TNC
Low Level DC on RF Output	+5 VDC \pm 5%, 50 mAmps maximum, Shield Ground.
Pin Assignment (Signal Mnemonic):	GPS ANT (COAX)

Honeywell
MK XXII EGPWS Installation Manual

E 4.2.13 OAT VOLTAGE REFERENCE OUTPUT

This output is an accurate voltage source for 500 Ω resistive temperature sensors.

Quantity	1	
Output Voltage	5.000 VDC \pm 10 mVDC (no load)	
Nominal Load	500 Ω	
Pin Assignment (Signal Mnemonic):	J1-25	(OAT_REF)

NOTE: This output has a source impedance of 4.42 K Ω , 0.1%.

E 4.2.14 LAMP DRIVER OUTPUTS

The MK IV, VI, VIII and XXII EGPWS supports two kinds of Ground/Open discrete outputs used to signal various discrete conditions. Monitor outputs are used to signal failure conditions for the MK IV, VI, VIII and XXII EGPWS. Monitor outputs default to an active state when there is a failure or if power is removed from the MK IV, VI, VIII and XXII EGPWS. The other Lamp Driver outputs are used to signal the alert or mode control status of the MK IV, VI, VIII and XXII EGPWS.

Short-term current limit protection is provided on all drivers for output shorting conditions. Ground going output discrettes may be connected together to produce a “wired OR” function for the active low state of the signals. If output discrettes are “wired or’ed” then diodes must be installed for isolation.

E 4.2.14.1 MONITOR OUTPUT CHARACTERISTICS

Quantity	3	
Type of Output:	Switch Closure to Ground	
Max. Open Circuit Voltage:	30 VDC	
Current Limit	1 Amp	
Potential Across “Closed” Switch:	2.5 VDC Max	
Pin Assignment (Signal Mnemonic):	See specific output in Category 13	(MON_OUT_xx)

NOTE: Intended to operate with +28VDC lamp sources and will not operate with +5VDC lamp sources.

E 4.2.15 DISCRETE OUTPUT CHARACTERISTICS

Quantity	9	
Type of Output:	Switch Closure to Ground	
Max. Open Circuit Voltage:	30 VDC	
Current Limit	500 mAmp (typical)	
Potential Across “Closed” Switch:	1 VDC Max	
Pin Assignment (Signal Mnemonic):	See specific output in Category 13	(DISC_OUT_xx)

E 4.2.16 AUDIO OUTPUTS

There are two audio outputs provided – one 8-ohm output and one 600-ohm output. There are several possible volume levels available with the MKIV/VI/VIII/XXII EGPWS as shown below, with maximum output being 4W (8 Ω) or 100mW (600 Ω). The actual audio level output by the EGPWS is dependent on several items:

- Selection of nominal alert audio volume level (max, -6, -12, -18 or -24 dB) via Category 14. (Section 5.3.14)

Honeywell
MK XXII EGPWS Installation Manual

- If a 'soft' Glideslope alert is being issued (given 6 dB below nominal alert volume level).
- If a Self Test is in progress, alerts are given 6 dB below nominal alert volume level.
- Selection of Mode 6 Low Volume Discrete (lowers callout volume by 6 dB - See Section 5.3.13).

E 4.2.16.1 HIGH LEVEL (SPEAKER) AUDIO OUTPUT

The 8-ohm output is capable of driving a speaker directly but can also be used to drive other devices with equal or higher impedance.

Quantity	1	
Maximum Power Output	4 Watts Nominal	
Nominal Output Impedance	8Ω	
Load Impedance	8Ω or greater	
Number of Available Power Output Levels	5 ¹	
Pin Assignment (Signal Mnemonic):		
Signal (+)	J1-70	(AUD_HL_H)
Return (-)	J1-71	(AUD_HL_L)

E 4.2.16.2 LOW LEVEL (INTERPHONE) AUDIO OUTPUT

The 600-ohm output is capable of driving one 600-ohm load at the specified level (or at a reduced level). This output is primarily designed for headphones and interphone systems.

Quantity	1	
Nominal Output Impedance	600Ω ±10%	
Maximum Single Channel Power Output	100 mW Nominal ()	
Available Power Output Levels	5 ¹	
Pin Assignment (Signal Mnemonic):		
Signal (+)	J1-75	(AUD_LL_H)
Return (-)	J1-74	(AUD_LL_L)

E 4.2.17 ARINC DIGITAL SERIAL OUTPUT BUSES

E 4.2.17.1 ARINC 429 OUTPUT BUS

The ARINC 429 output buses are defined in the terrain display select Section 5.3.6.3, output 429 bus group.

Quantity	2	
Format	DITS, ARINC 429	
Low Speed Data Rate	12.0 KBPS to 14.5 KBPS	
High Speed Data Rate	100 KBPS ± 1%	
Direction of Information Flow	Type 'A' broadcast for ARINC 429	
Word/Frame Structure	Type 'B' 32 bit words consisting of 8 bits label and 24 bits data/status	
Data definition	Refer to Section 7	
Pin Assignment (Signal Mnemonic):		
Bus #1 (A leg)	J2-43	(429TX_1A)
Bus #1 (B leg)	J2-42	(429TX_1B)
Bus #2 (A leg)	J2-26	(429TX_2A)
Bus #2 (B leg)	J2-9	(429TX_2B)

2

² Five Selectable levels excluding the Mode 6 Audio Reduction function.

Honeywell
MK XXII EGPWS Installation Manual

E 4.2.17.2 ARINC 453 OUTPUT BUS

Quantity	2
Format	1600 bit Manchester BI-phase per ARINC 708A
Data Rate	1 Mb per second
Word/Frame Structure	Refer to Section 7.2
Data definition	Refer to Section 7.2

Pin Assignment (Signal Mnemonic):

Bus #1 (A leg)	J1-58	(KCPB_1A)
Bus #1 (B leg)	J1-59	(KCPB_1B)
Bus #2 (A leg)	J1-56	(KCPB_2A)
Bus #2 (B leg)	J1-57	(KCPB_2B)

E 4.2.18 FRONT PANEL TEST INTERFACE

The MK IV, VI, VIII and XXII EGPWS provides a 15 pin (double density, D-Sub) test connector on the front panel, which provides interfaces for various test and maintenance functions. This connector provides the following interfaces.

E 4.2.18.1 RS-232 MAINTENANCE PORT (SERIAL PORT 4)

One port is provided which meets the characteristics specified in RS232C. This bus can be used to read internal data from the MK IV, VI, VIII and XXII EGPWS for both bench, and aircraft testing or transmitting configuration data for selected EGPWS interfaces and options.

Baud Rate	19,200
Parity	None
Data bits	8
Stop bits	1
Maximum Recommended Cable Length	15 meters
Pin Assignment (Signal Mnemonic):	
Transmit	J3-4 (RS232TXD_MON)
Receive	J3-3 (RS232RXD_MON)
Common	J3-1 (GND)

Honeywell
MK XXII EGPWS Installation Manual

E 4.2.18.2 PCMCIA / SMARTCABLE PORT

One port is provided which meets the Motorola SPI characteristics. The PCMCIA / SmartCable interface allows for both the uploading, and downloading of internal MK IV, VI, VIII and XXII EGPWS information. Using this interface system, software and databases can be updated. Control of the upload/download process is accomplished by insertion of the PCMCIA card / SmartCable to the MK IV, VI, VIII and XXII EGPWS front panel test connector. LEDs are provided on the SmartCable for PCMCIA interface operation. The PCMCIA / SmartCable is not intended as an on-line/in-flight storage medium and must be removed after completion of the upload/download operation.

Electrical Characteristics	Refer to the Motorola SPI specification	
Data definition	Refer to the Motorola SPI specification	
Maximum Recommended Cable Length	2 meters	
Pin Assignment (Signal Mnemonic):		
Clock	J3-7	(SPICLK)
Master Data Out	J3-9	(SPIMOSI)
Master Data In	J3-8	(SPIMISO)
SmartCable Select	J3-10	(SPISEL_SC#)
SmartCable +5VDC	J3-6	(SC_PWR)
SmartCable +5VDC Return	J3-1	(GND)
PCMCIA Card Present	J3-2	(CARD_PRES#)
SmartCable Ground	J3-12, -13, -14	(GND)

NOTE: SmartCable +5VDC Return is common with RS-232 Maintenance Port common.

E 4.2.18.3 GSE PRESENT DISCRETE INPUT

A discrete input for test and Ground Support Equipment is provided. Grounding this pin indicates to the EGPWS that test or Ground Support Equipment is connected to the system.

Active Threshold Voltage (Logic True)	< 0.8 VDC	
Inactive Threshold Voltage (Logic False)	> 2.0 VDC	
Input Impedance	> 20 K Ω	
Maximum Fault Current	< 500 μ Amps	
Pin Assignment (Signal Mnemonic):	J3-11	(GSE_PRES#)

E 4.2.19 FRONT PANEL STATUS INDICATORS

The MK XXII EGPWC front panel provides three LEDs for indicating system and LRU status. A yellow LED labeled "EXTERNAL FAULT" is activated when a signal fault external to the MK XXII EGPWS is detected. A green LED labeled "COMPUTER OK" is activated when the MK XXII EGPWS itself is okay. A red LED labeled "COMPUTER FAIL" is activated when the MK XXII EGPWS has detected an internal computer fault.

Refer to Product Specifications 965-1590-601 for a detailed discussion of status indications, recommended maintenance actions, Self-Test activation and response.

Honeywell
MK XXII EGPWS Installation Manual

E 5 AIRCRAFT APPLICATION DATA

This section describes the MK XXII EGPWS interfaces for aircraft applications. Section E 5.1 is a listing of the selection categories defining the various aircraft sensor interfaces and EGPWS functional options. Section E 5.2 describes how the Category ID's are selected and programmed for the interface to aircraft sensors and EGPWS functional options. Section E 5.3 and its sub-sections define the specific aircraft interfaces available for the MK XXII EGPWS.

E 5.1 CONFIGURATION TYPES

The selection of the basic interfaces to the MK XXII EGPWS can be found in the following categories:

Category 1	Aircraft / Mode Type Select
Category 2	Air Data Input Select
Category 3	Position Input Select
Category 4	Altitude Callous
Category 5	Audio Menu Select
Category 6	Terrain Display Select
Category 7	Options 1 Select
Category 8	Radio Altitude Input Select
Category 9	Navigation Input Select
Category 10	Attitude Input Select
Category 11	Heading Input Select
Category 12	Windshear Input Select
Category 13	I / O Discretes Select
Category 14	Audio Output Level
Category 15	Autorotation Threshold

E 5.2 CONFIGURATION SELECTION

Each category provides information relative to aircraft interfaces or EGPWS functional options required or used for EGPWS operation. Each category must be defined for the specific aircraft application according to the available aircraft sensors or equipment and the intended EGPWS function. The choices provided are available in each category identified by an "ID" number. The ID number is selected for each category and is used to load the selected configuration in a configuration module installed in the aircraft wiring (physically part of one of the EGPWC mating connectors). For example, selecting Category 2, ID 1 defines the Air Data Input as ARINC 429 per Table E 3.1.2-1 in Category 2. With this ID programmed into the configuration module the EGPWC will look for and use the interface defined for this ID. Table E 3 can be used to record the selected ID for each category for later reference when programming the configuration module. This programming is accomplished using a programming software tool available from Honeywell or generating a data text string and transferring this data (in either case) via the EGPWC RS-232C to the configuration module. Once programmed, the configuration is available and read by any installed EGPWC on power up.

Honeywell
MK XXII EGPWS Installation Manual

TABLE E 3 CATEGORY ID SELECTION PROCEDURE

Step (Category)	Signal Selection	Instruction		Ident No.
1	Selects: a) Aircraft Type b) Mode Type	Using Table 5.3.1, and any sub-tables contained within, locate the Aircraft / Mode Type.	Record the Ident (ID No.) on the space available on Ident column of this table.	_____ ID #
2	Selects: a) Air Data Source	Using Table 5.3.2, and any sub-tables contained within, locate the desired Air Data signal type.	Record the Ident (ID No.) on the space available on Ident column of this table.	_____ ID #
3	Selects: a) Position Source	Using Table 5.3.3, and any sub-tables contained within, locate the desired Position signal type.	Record the Ident (ID No.) on the space available on Ident column of this table.	_____ ID #
4	Selects: a) Altitude Callouts Menu	Using Table 5.3.4 and any sub-tables contained within, locate the desired Altitude Call-Out Menu.	Record the Ident (ID No.) on the space available on Ident column of this table.	_____ ID #
5	Selects: a) Audio Menu	Using Table 5.3.5 and any sub-tables contained within, locate the desired Audio Menu type.	Record the Ident (ID No.) on the space available on Ident column of this table.	_____ ID #
6	Selects: a) Display Config.	Using Table 5.3.6 and any sub-tables contained within, locate the desired Display indicator type / range bus type.	Record the Ident (ID No.) on the space available on Ident column of this table.	_____ ID #
7	Selects: a) Steep Approach Enabled b) TA&D Alternate Pop Up c) Peaks Mode Enable d) Obstacle Awareness Enable e) Bank Angle Enable f) Weight on Wheels Reversal g) GPS Altitude Reference	Using Table 5.3.7 and any sub-tables contained within, select the desired True or False condition for TA&D Alternate Pop Up, Obstacle Awareness Enable, Peaks Mode Enable, Bank Angle Enable, WOW Reversal Select, Steep Approach Enabled functions and GPS Altitude Reference type.	Record the Ident (ID No.) on the space available on Ident column of this table.	_____ ID #
8	Selects: a) Radio Altitude Source	Using Table 5.3.8, and any sub-tables contained within, locate the desired Radio Altitude signal type.	Record the Ident (ID No.) on the space available on Ident column of this table.	_____ ID #

Honeywell
MK XXII EGPWS Installation Manual

Step (Category)	Signal Selection	Instruction		Ident No.
9	Selects: a) Glideslope and/or Localizer Source	Using Table 5.3.9, and any sub-tables contained within, locate the desired Navigation signal type.	Record the Ident (ID No.) on the space available on Ident column of this table.	_____ ID #
10	Selects: a) Attitude Source	Using Table 5.3.10, and any sub-tables contained within, locate the desired Attitude signal type.	Record the Ident (ID No.) on the space available on Ident column of this table.	_____ ID #
11	Selects: a) Magnetic Heading Source	Using Table 5.3.11, and any sub-tables contained within, locate the desired Magnetic Heading signal type.	Record the Ident (ID No.) on the space available on Ident column of this table.	_____ ID #
12	Selects:	Using Table 5.3.12, no Windshear is available for helicopter applications. Please select ID 0.	Record the Ident (ID No.) on the space available on Ident column of this table.	0 _____ ID #
13	Selects: a) Input Discrete Functions b) Output Discrete Functions	Using Table 5.3.13, and any sub-tables contained within, locate the desired I / O Discrete type.	Record the Ident (ID No.) on the space available on Ident column of this table.	_____ ID #
14	Selects: a) Audio Output Level	Using Table 5.3.14, and any sub-tables contained within, locate the desired Volume type.	Record the Ident (ID No.) on the space available on Ident column of this table.	_____ ID #
15	Selects: a) Autorotation Threshold	Using Table 5.3.15, locate the desired Autorotation Threshold. This Category is used on helicopters only.	Record the Ident (ID No.) on the space available on Ident column of this table.	_____ ID #

LIMITATIONS: The described use of the configuration module provides for maximum flexibility in selection of input sensors and output behavior. Every attempt has been made to avoid conflicts arising between categories and to reflect the known configurations of aircraft. However in the case of input sensors it should not be construed that all combinations are valid configurations. There may be configurations not supported by the EGPWS software configuration building process (which will cause the EGPWS to fail in an obvious manner). In general you can not have redundancy through the mixing of analog and digital sources, however redundant digital signals on different buses are permissible. As it is not practical to verify all possible sensor combinations, verification of particular sensor combinations is part of the installation certification process. If you intend to implement a sensor configuration not currently identified in Section E 3, please contact Honeywell or an authorized dealer/installer.

E 5.3 CONFIGURATION SELECTION TABLES

Configuration selection is defined by category (or group of functions or inputs). The Category number identifies the subsection where the details are defined. For example Air Data, Category 2, is defined in Section E 5.3.2, and Position Input Source, Category 3, is defined in Section E 5.3.3.

Honeywell
MK XXII EGPWS Installation Manual

E 5.3.1 CATEGORY 1, AIRCRAFT / MODE TYPE SELECT

Category 1 defines the Aircraft Type. This determines the warning modes algorithm configuration, gear type and Torque Interface characteristics.

The following table provides ID values for each of the basic helicopter type descriptions. For purposes of selecting an ID, use the "Description" provided in Table E 3.1.1 appropriate to the desired variables as given above. Refer to the identified Table E .3.1.1-X for the Engine Torque input requirements.

Honeywell
MK XXII EGPWS Installation Manual

TABLE E 3.1.1: HELICOPTER TYPE ID AND TORQUE INPUTS FOR EGPWS MK XXII

ID	Torque Type Table (E 3.1.1-x)	DESCRIPTION	Effectivity	
			App.	Cfg.
128	0	Helo, S-76B/C+, Retractable Gear	-003	-003
129	1	Helo, S-76C/A++, Retractable Gear	-003	-003
130	2	Helo, S-76A/A+, Retractable Gear	-003	-003
131	3	Helo, Bell 212/412 Fixed Gear	-006	-006
132	4	Helo, EC-155B, Retractable Gear	-006	-006
133	5	Helo, MD 900, Fixed Gear	-006	-006
134	6	Helo, Super Puma, Retractable Gear	-008	-008
135	7	Helo, AS365 Dauphin N1, N2, Retractable Gear	-008	-008
136	8	Helo, AS365 Dauphin N3, Retractable Gear	-008	-008
137	9	Helo, Bell 430, Retractable Gear	-008	-008
138	10	Helo, Bell 407, Fixed Gear	-008	-008
139	5	Helo, Agusta 109E Power, Retractable Gear	-008	-008
Reserved				
141	11	Bell 212/412, Fixed gear DC torque	-010	-010
142	9	Bell 430, Fixed gear	-010	-010
Reserved				
Reserved				
145	12	Coast Guard HH-65, Dauphin N2	-010	-010
146	13	Generic Helo, No Torque, Retractable Gear, Tail Strike Type 1	-011	-011
147	13	Generic Helo, No Torque, Retractable Gear, Tail Strike Type 2	-011	-011
148	13	Generic Helo, No Torque, Fixed Gear, Tail Strike Type 1	-011	-011
149	13	Generic Helo, No Torque, Fixed Gear, Tail Strike Type 2	-011	-011
150	14	Generic Helo, Common DC Torque, Retractable Gear, Tail Strike Type 1.	-011	-011
151	14	Generic Helo, Common DC Torque, Retractable Gear, Tail Strike Type 2.	-011	-011
152	14	Generic Helo, Common DC Torque, Fixed Gear, Tail Strike Type 1.	-011	-011
153	14	Generic Helo, Common DC Torque, Fixed Gear, Tail Strike Type 2.	-011	-011
154	15	Generic Helo, Shadin 429 Torque, Retractable Gear, Tail Strike Type 1.	-011	-011
155	15	Generic Helo, Shadin 429 Torque, Retractable Gear, Tail Strike Type 2.	-011	-011
156	15	Generic Helo, Shadin 429 Torque, Fixed Gear, Tail Strike Type 1.	-011	-011
157	15	Generic Helo, Shadin 429 Torque, Fixed Gear, Tail Strike Type 2.	-011	-011

Note:

For any airframe not listed in table E 3.1.1 and help selecting application ID contact Honeywell GPWS hot line 1 800 813-2099.

Category 1 ID type 146, 147, 148 and 149 allow interface to airframes without torque input, these installation will not provide autorotation detection and have Mode 1 inhibited. See section 3.3.1 for additional commentary and instructions.

Honeywell
MK XXII EGPWS Installation Manual

E 5.3.1.2 ENGINE TORQUE DATA SELECTION

WHEN A SINGLE ENGINE HELICOPTER IS ADDED TO THIS SECTION, IT NEEDS TO BE TREATED AS IF THERE WERE TWO ENGINES VIA AIRCRAFT WIRING. THE SRD REQUIREMENTS ARE ALL WRITTEN FOR TWO ENGINES, BUT SINGLE ENGINES WERE ACCOUNTED FOR AS LONG AS THIS METHOD IS USED.

TABLE E 3.1.1-0
TORQUE DATA SELECT 0 (S-76B/C+)

CHANNEL RX429-8	CONNECT TO: Eng #1 (low speed)		Fault Designation: ENGINE 1 BUS					
			Bus Type: Basic					
A = J2-24 B = J2-07	Data Torque		<u>Label</u> 243	<u>Sig. Bits</u> 15	<u>Range</u> 799%	<u>Signal Type</u> Basic	<u>Resolution</u> 0.1	<u>Rate (ms)</u> 200
CHANNEL RX429-5 (Note 1)	CONNECT TO: Eng #2 (low speed)		Fault Designation: ENGINE 2 BUS					
			Bus Type: Basic					
A = J2-21 B = J2-04	Data Torque		<u>Label</u> 243	<u>Sig. Bits</u> 15	<u>Range</u> 799%	<u>Signal Type</u> Basic	<u>Resolution</u> 0.1	<u>Rate (ms)</u> 200

Note 1: Digital Radar Altitude (type 2) can not be used with this configuration.

TABLE E 3.1.1-1
TORQUE DATA SELECT 1 (S-76C/A++)

SIGNAL	CONNECTION		SUMMARY DATA					
Engine Torque #1	(+) = J1-26 (-) = J1-27		Format: DC Input Type: Basic Fault Designation: ENGINE TORQUE 1					
Engine Torque #2	(+) = J1-66 (-) = J1-47		Format: DC Input Type: Basic Fault Designation: ENGINE TORQUE 2					

TABLE E 3.1.1-2
TORQUE DATA SELECT 2 (S-76A/A+)

SIGNAL	CONNECTION		SUMMARY DATA					
Engine Torque #1	(+) = J1-26 (-) = J1-27		Format: DC Input Type: Basic Fault Designation: ENGINE TORQUE 1 Validity: none					
Engine Torque #2	(+) = J1-66 (-) = J1-47		Format: DC Input Type: Basic Fault Designation: ENGINE TORQUE 2 Validity: none					

TABLE E 3.1.1-3
TORQUE DATA SELECT 3 (BELL 212/412)

SIGNAL	CONNECTION		SUMMARY DATA					
Engine Torque #1	(X) = J2-1 (Y) = J2-2 (Z) = J2-18 Reference (H) = J2-34 (C) = J2-35		Format: 5 Wire Synchro Input Type: Basic Fault Designation: ENGINE TORQUE 1 Validity: none					
Engine Torque #2	(X) = J2-19 (Y) = J2-20 (Z) = J2-3 Reference (H) = J2-34 (C) = J2-35		Format: 5 Wire Synchro Input Type: Basic Fault Designation: ENGINE TORQUE 2 Validity: none					

Honeywell
MK XXII EGPWS Installation Manual

TABLE E 3.1.1-4
TORQUE DATA SELECT 4 (EC-155B, AS-365N3)

CHANNEL RX429-8	CONNECT TO: Eng #1 (high speed)		Fault Designation: ENGINE 1 BUS Bus Type: Basic					
A = J2-24 B = J2-07	Data Torque		<u>Label</u> 053	<u>Sig. Bits</u> 15	<u>Range</u> 0 to 180%	<u>Signal Type</u> Basic	<u>Resolution</u> 0.0078125	<u>Rate (ms)</u> 20
CHANNEL RX429-5 (Note 1)	CONNECT TO: Eng #2 (high speed)		Fault Designation: ENGINE 2 BUS Bus Type: Basic					
A = J2-21 B = J2-04	Data Torque		<u>Label</u> 053	<u>Sig. Bits</u> 15	<u>Range</u> 0 to 180%	<u>Signal Type</u> Basic	<u>Resolution</u> 0.0078125	<u>Rate (ms)</u> 20

Note 1: Digital Radar Altitude (type 2) can not be used with this configuration.

TABLE E 3.1.1-5
TORQUE DATA SELECT 5 (MD900/902, AGUSTA 109E)

CHANNEL 429 422RX_1 Note 1	CONNECT TO: Eng #1		Fault Designation: ENGINE 1 BUS Bus Type: (RS-422 – 9600 baud)					
A = J2-36 B = J2-37	Data Torque Torque Valid		<u>Word</u> 5 13	<u>Sig. Bits</u> 15 16	<u>Range</u> 256% N/A	<u>Signal Type</u> Basic Basic	<u>Resolution</u> 0.0078125 N/A	<u>Rate (ms)</u> 250 250
CHANNEL RX422-2 Note 1	CONNECT TO: Eng #2		Fault Designation: ENGINE 2 BUS Bus Type: (RS-422 – 9600 baud)					
A = J2-10 B = J2-11	Data Torque Torque Valid		<u>Word</u> 5 13	<u>Sig. Bits</u> 15 16	<u>Range</u> 256% N/A	<u>Signal Type</u> Basic Basic	<u>Resolution</u> 0.0078125 N/A	<u>Rate (ms)</u> 250 250

Note 1: This type is only compatible with display type 242 that uses RX429-8 for range control.

TABLE E 3.1.1-6
TORQUE DATA SELECT 6 (SUPER PUMA)

SIGNAL	CONNECTION		SUMMARY DATA		
Engine Torque #1	(+) = J1-26 (-) = J1-27		Format: DC Input Type: Basic Fault Designation: ENGINE TORQUE 1 Validity: none		
Engine Torque #2	(+) = J1-66 (-) = J1-47		Format: DC Input Type: Basic Fault Designation: ENGINE TORQUE 2 Validity: none		

TABLE E 3.1.1-7
TORQUE DATA SELECT 7 (AS365 DAUPHIN N1 & N2)

SIGNAL	CONNECTION		SUMMARY DATA		
Engine Torque #1	(+) = J1-26 (-) = J1-27		Format: DC Input Type: Basic Fault Designation: ENGINE TORQUE 1 Validity: none		
Engine Torque #2	(+) = J1-66 (-) = J1-47		Format: DC Input Type: Basic Fault Designation: ENGINE TORQUE 2 Validity: none		

Honeywell
MK XXII EGPWS Installation Manual

TABLE E 3.1.1-8
TORQUE DATA SELECT 8 (AS365 DAUPHIN N3)

CHANNEL RX429-8	CONNECT TO: Eng #1 (low speed)		Fault Designation: ENGINE 1 BUS						
			Bus Type: Basic						
A = J2-24 B = J2-07	Data Torque		<u>Label</u> 211	<u>Sig. Bits</u> 15	<u>Range</u> 799%	<u>Signal Type</u> Basic	<u>Resolution</u> 0.1	<u>Rate (ms)</u> 100	
CHANNEL RX429-5 (Note 1)	CONNECT TO: Eng #2 (low speed)		Fault Designation: ENGINE 2 BUS						
			Bus Type: Basic						
A = J2-21 B = J2-04	Data Torque		<u>Label</u> 211	<u>Sig. Bits</u> 15	<u>Range</u> 799%	<u>Signal Type</u> Basic	<u>Resolution</u> 0.1	<u>Rate (ms)</u> 100	

Note 1: Digital Radar Altitude (type 2) can not be used with this configuration.

TABLE E 3.1.1-9
TORQUE DATA SELECT 9 (BELL 430)

CHANNEL RX429-8	CONNECT TO: Eng #1 (low speed)		Fault Designation: ENGINE 1 BUS						
			Bus Type: Basic						
A = J2-24 B = J2-07	Data Torque		<u>Label</u> 050	<u>Sig. Bits</u> 15	<u>Range</u> 0 to +126	<u>Signal Type</u> Basic	<u>Resolution</u> 0.1	<u>Rate (ms)</u> 100	
CHANNEL RX429-5 (Note 1)	CONNECT TO: Eng #2 (low speed)		Fault Designation: ENGINE 2 BUS						
			Bus Type: Basic						
A = J2-21 B = J2-04	Data Torque		<u>Label</u> 050	<u>Sig. Bits</u> 15	<u>Range</u> 0 to +126	<u>Signal Type</u> Basic	<u>Resolution</u> 0.1	<u>Rate (ms)</u> 100	

Note 1: Digital Radar Altitude (type 2) can not be used with this configuration.

TABLE E 3.1.1-10
TORQUE DATA SELECT 10 (BELL 407)

SIGNAL	CONNECTION		SUMMARY DATA					
Engine Torque #1	(+) = J1-26 (-) = J1-27		Format: DC Input Type: Basic Fault Designation: ENGINE TORQUE 1 Validity: none					
Engine Torque #2	(+) = J1-66 (-) = J1-47		Format: DC Input Type: Basic Fault Designation: ENGINE TORQUE 2 Validity: none					

TABLE E 3.1.1-11
TORQUE DATA SELECT 11 (BELL 212/412)

SIGNAL	CONNECTION		SUMMARY DATA					
Engine Torque #1	(+) = J1-26 (-) = J1-27		Format: DC Input Type: Basic Fault Designation: ENGINE TORQUE 1 Validity: none					
Engine Torque #2	(+) = J1-66 (-) = J1-47		Format: DC Input Type: Basic Fault Designation: ENGINE TORQUE 2 Validity: none					

Honeywell
MK XXII EGPWS Installation Manual

TABLE E 3.1.1-12
TORQUE DATA SELECT 14 (COAST GUARD HH-65)

SIGNAL	CONNECTION		SUMMARY DATA
Engine Torque #1	(+) = J1-26 (-) = J1-27		Format: DC Input Type: Basic Fault Designation: ENGINE TORQUE 1 Validity: none
Engine Torque #2	(+) = J1-66 (-) = J1-47		Format: DC Input Type: Basic Fault Designation: ENGINE TORQUE 2 Validity: none

TABLE E3.1.1-13
: TORQUE DATA SELECT 15 (GENERIC FIXED TORQUE 20%)

SIGNAL	CONNECTION		SUMMARY DATA
Engine Torque #1	No Connection		Format: Fixed Internal Input Type: Basic Fault Designation:
Engine Torque #2	No Connection		Format: Fixed Internal Input Type: Basic Fault Designation:

TABLE E3.1.1-14
TORQUE DATA SELECT 16 (COMMON DC TORQUE)

SIGNAL	CONNECTION		SUMMARY DATA
Engine Torque #1	(+) = J1-26 (-) = J1-27		Format: DC Input Type: Basic Fault Designation: ENGINE TORQUE 1
Engine Torque #2	(+) = J1-66 (-) = J1-47		Format: DC Input Type: Basic Fault Designation: ENGINE TORQUE 2

TABLE E3.1.1-15
TORQUE DATA SELECT 17 (GENERIC SHADIN DC TO 429 CONVERTER)

CHANNEL RX429-8	CONNECT TO: Eng #1 (high speed)		Fault Designation: ENGINE 1 BUS Bus Type: Basic					
			Label	Sig. Bits	Range	Signal Type	Resolution	Rate (ms)
A = J2-24	Data		053	15	0 to 180%	Basic	0.0078125	50
B = J2-07	Torque 1 Torque 2		054	15	0 to 180%	Basic	0.0078125	50

Note 1: The actual number of significant bits is 16 but 15 bits will support the data range. This is adjusted to make the input processing work with the actual MSB = to bit 29.

Honeywell
MK XXII EGPWS Installation Manual

E 5.3.2 CATEGORY 2, AIR DATA INPUT SELECT

The following table provides identification of the Air Data source type. The entry in the Air Data Type corresponds to a table that provides detailed information on the configuration. For example, the details for Air Data Type #2 are found in Table E 3.1.2. In this category, only the following signals are defined:

- Uncorrected Barometric Altitude in analog and/or RS-422 or ARINC 429 format, and associated validity.
- Temperature (Outside Air or Static Air) in analog or ARINC 429 format.
- Corrected Barometric Altitude in ARINC 429 format.
- Barometric Rate in ARINC 429 format.
- Computed Airspeed in ARINC 429 format.

TABLE E 3.1.2: AIR DATA INPUT SELECT FOR EGPWS MKXXII

ID	Air Data Type (Table E 3.1.2-x)	Description	Effectivity	
			App.	Cfg.
0	0	Analog - altitude and 500Ω OAT (i.e., CIC 04077)	-001	-001
1	1	Digital – ARINC 429 (i.e., Bendix KDC 281)	-001	-001
2	2	Digital – ARINC 575 (i.e., Collins ADC-80, 81, 82)	-001	-001
3	3	Analog - altitude and 500Ω OAT (i.e., Collins ADS-65)	-001	-001
4	4	Analog - altitude and 500Ω OAT (i.e., CIC 02702)	-001	-001
5	5	Digital – ARINC 429 with Corrected Altitude label 204 (i.e., Bendix KDC 481T)	-001	-001
6	6	Digital – ARINC 429 without Baro Rate label 212 (i.e., Honeywell AZ-810)	-001	-001
10	10	Digital – ARINC 429 and 500Ω OAT (i.e. Shadin 2000)	-003	-003
11	11	Analog – altitude and 500Ω OAT (i.e., Honeywell AZ-241 or AZ-800 with additional OAT). (Note 1)	-004	-004
12	12	Analog – altitude and internal constant for OAT (i.e., Honeywell AZ-800 or AZ-241). (Note 1)	-006	-006

Note 1: The AZ-800 provides an OAT signal with reference provided by the ADC. This is not compatible with the EGPWS interface. The AZ-241 provides no OAT interface. The customer may either add an additional OAT probe (ID 11) or use the internal constant (ID 12). ID 11 is to be recommended in operations in temperature extremes.

Honeywell
MK XXII EGPWS Installation Manual

TABLE E 3.1.2-0: AIR DATA INPUT SELECT #0

SIGNAL	CONNECTION		SUMMARY DATA		
Uncorrected Barometric Altitude	(+) = J1-62 (-) = J1-43		Format: DC with Validity Flag Input Type: Basic Fault Designation: BAROMETRIC ALTITUDE FAULT Validity: Barometric Alt Valid (+28V)		
Outside Air Temp Total Air Temperature Probe element Excitation: Temp Input (probe element): Ground	5 V = J1-25 (+) = J1-63 (-) = J1-44 GND = J1-53		Format: DC Input Type: Basic Fault Designation: STATIC AIR TEMPERATURE FAULT  Note: Nominal 500 Ω Temperature Probe only. Resistance @ 0°C: 500Ω ± 0.6Ω Connection example: CIC Temperature Sensor, P/N 05257 (2 wire). Connect positive lead to both J1-25 and J1-63. Connect negative lead to both J1-44 and J1-53 (Chassis Ground). Other probes may have three contacts.		
Computed Airspeed	No Connection	N/A	Substitute Ground Speed for Airspeed (airspeed is not available with this air data input)		
PIN FUNCTION	CONNECTION	PIN TYPE	CHANNEL DESIGNATION REFERENCE	Polarity/Configuration	References
Barometric Altitude Validity Discrete (+28V)	J1-9	Input	28V_DISC_08	>+17V = Valid < +4.4V = Invalid	6.6.19 4.2.7
Configuration Data			Type	Summary Data	
Derive Baro Altitude Rate			Analog	Baro Altitude Rate is derived using Uncorrected Barometric Altitude. Baro Rate is not available with this air data source.	

TABLE E 3.1.2-1: AIR DATA INPUT SELECT #1

CHANNEL 429RX_2	CONNECT TO: ADC #1 (Low Speed) Format: ARINC 429		Fault Designation: AIR DATA BUS Bus Type: Basic					
A = J2-39 B = J2-38	Data		Label	Sig. Bits	Range	Signal Type	Resolution	Rate (ms)
	Uncorrected. Baro. Alt		203	17	±131,072 FT	Basic	1.0	31.3-62.5
	Computed Airspeed		206	14	±1024 KTS	Basic	0.0625	62.5-125
	Barometric Rate		212	11	±32768 FPM	Basic	16.0	31.3-62.5
	Static Air Temperature		213	11	512 Degrees	Basic	0.25	250-500

TABLE E 3.1.2-2: AIR DATA INPUT SELECT #2

CHANNEL 429RX_2	CONNECT TO: ADC #1 (Low Speed) Format: ARINC 575		Fault Designation: AIR DATA BUS Bus Type: Basic					
A = J2-39 B = J2-38	Data		Label	Sig. Bits	Range	Signal Type	Resolution	Rate (ms)
	Uncorrected. Baro. Alt		203	17	±131,072 FT	Basic	1.0	31.3-62.5
	Computed Airspeed		206	13	±1024 KTS	Basic	0.125	62.5-125
	Barometric Rate		212	11	±20480 FPM	Basic	10.0	31.3-62.5
	Static Air Temperature		213	10	±512 Degrees	Basic	0.5	250-500

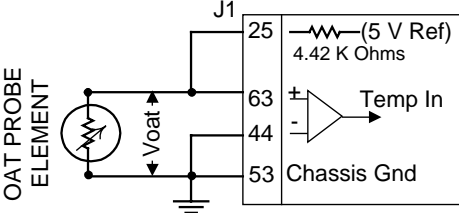
Honeywell
MK XXII EGPWS Installation Manual

TABLE E 3.1.2-3: AIR DATA INPUT SELECT #3

SIGNAL	CONNECTION		SUMMARY DATA		
Uncorrected Barometric Altitude	(+) = J1-62 (-) = J1-43		Format: DC with Validity Flag Input Type: Basic Fault Designation: BAROMETRIC ALTITUDE FAULT Validity: Barometric Alt Valid (+28V)		
Outside Air Temp Total Air Temperature Probe element Excitation: Temp Input (probe element): Ground	5 V = J1-25 (+) = J1-63 (-) = J1-44 GND = J1-53		Format: DC Input Type: Basic Fault Designation: STATIC AIR TEMPERATURE FAULT <div style="text-align: center;"> </div> <p>Note: Nominal 500 Ω Temperature Probe only. Resistance @ 0°C: 500Ω ± 0.6Ω</p> <p>Connection example: CIC Temperature Sensor, P/N 05257 (2 wire). Connect positive lead to both J1-25 and J1-63. Connect negative lead to both J1-44 and J1-53 (Chassis Ground).</p> <p>Other probes may have three contacts.</p>		
Computed Airspeed	No Connection	N/A	Substitute Ground Speed for Airspeed (airspeed is not available with this air data input)		
PIN FUNCTION	CONNECTION	PIN TYPE	CHANNEL DESIGNATION REFERENCE	Polarity/Configuration	References
Barometric Altitude Validity Discrete (+28V)	J1-9	Input	28V_DISC_08	>+17V = Valid < +4.4V = Invalid	6.6.19 4.2.7
Configuration Data			Type	Summary Data	
Derive Baro Altitude Rate			Analog	Baro Altitude Rate is derived using Uncorrected Barometric Altitude. Baro Rate is not available with this air data source.	

Honeywell
MK XXII EGPWS Installation Manual

TABLE E 3.1.2-4: AIR DATA INPUT SELECT #4

SIGNAL	CONNECTION		SUMMARY DATA		
Uncorrected Barometric Altitude	(+) = J1-62 (-) = J1-43		Format: DC with Validity Flag Input Type: Basic Fault Designation: BAROMETRIC ALTITUDE FAULT Validity: Barometric Alt Valid (+28V)		
Outside Air Temp Total Air Temperature Probe element Excitation: Temp Input (probe element): Ground	5 V = J1-25 (+) = J1-63 (-) = J1-44 GND = J1-53		Format: DC Input Type: Basic Fault Designation: STATIC AIR TEMPERATURE FAULT  Note: Nominal 500 Ω Temperature Probe only. Resistance @ 0°C: 500Ω ± 0.6Ω Connection example: CIC Temperature Sensor, P/N 05257 (2 wire). Connect positive lead to both J1-25 and J1-63. Connect negative lead to both J1-44 and J1-53 (Chassis Ground). Other probes may have three contacts.		
Computed Airspeed	No Connection	N/A	Substitute Ground Speed for Airspeed (airspeed is not available with this air data input)		
PIN FUNCTION	CONNECTION	PIN TYPE	CHANNEL DESIGNATION REFERENCE	Polarity/Configuration	References
Barometric Altitude Validity Discrete (+28V)	J1-9	Input	28V_DISC_08	>+17V = Valid < +4.4V = Invalid	6.6.19 4.2.7
Configuration Data			Type	Summary Data	
Derive Baro Altitude Rate			Analog	Baro Altitude Rate is derived using Uncorrected Barometric Altitude. Baro Rate is not available with this air data source.	

TABLE E 3.1.2-5: AIR DATA INPUT SELECT #5

CHANNEL 429RX 2	CONNECT TO: ADC #1 (Low Speed) Format: ARINC 429		Fault Designation: AIR DATA BUS Bus Type: Basic					
	Data		Label	Sig. Bits	Range	Signal Type	Resolution	Rate (ms)
A = J2-39 B = J2-38	Uncorrected. Baro. Alt		203	17	±131,072 FT	Basic	1.0	31.3-62.5
	Corrected Baro. Alt		204	17	±131,072 FT	Basic	1.0	31.3-62.5
	Computed Airspeed		206	14	±1024 KTS	Basic	0.0625	62.5-125
	Barometric Rate		212	11	±32678 FPM	Basic	16.0	31.3-62.5
	Static Air Temperature		213	11	±512 Degrees	Basic	0.25	250-500

Honeywell
MK XXII EGPWS Installation Manual

TABLE E 3.1.2-6: AIR DATA INPUT SELECT #6

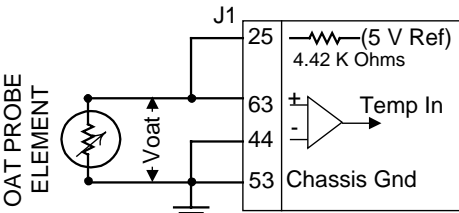
CHANNEL 429RX_2	CONNECT TO: ADC #1 (Low Speed) Format: ARINC 429		Fault Designation: AIR DATA BUS Bus Type: Basic					
A = J2-39 B = J2-38	Data Uncorrected. Baro. Alt Computed Airspeed Static Air Temperature		Label 203 206 213	Sig. Bits 17 14 11	Range ±131,072 FT ±1024 KTS ±512 Degrees	Signal Type Basic Basic Basic	Resolution 1.0 0.0625 0.25	Rate (ms) 31.3-62.5 62.5-125 250-500
Configuration Data			Type			Summary Data		
Derive Baro Altitude Rate			Digital			Baro Altitude Rate is derived using Uncorrected Barometric Altitude. Baro Rate is not available with this air data source.		

TABLE E 3.1.2-10: AIR DATA INPUT SELECT #10

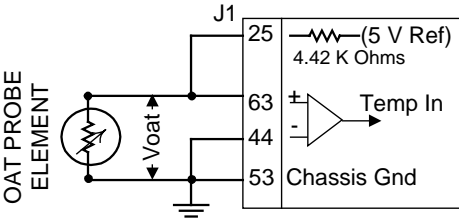
CHANNEL 429RX_2	CONNECT TO: ADC #1 (Low Speed) Format: ARINC 429		Fault Designation: AIR DATA BUS Bus Type: Basic					
A = J2-39 B = J2-38	Data Uncorrected. Baro. Alt Corrected Baro. Alt Computed Airspeed Barometric Rate		Label 203 204 206 212	Sig. Bits 17 17 14 11	Range ±131,072 FT ±131,072 FT ±1024 KTS ±32678 FPM	Signal Type Basic Basic Basic Basic	Resolution 1.0 1.0 0.0625 16.0	Rate (ms) 31.3-62.5 31.3-62.5 62.5-125 31.3-62.5
Outside Air Temp Total Air Temperature			Format: DC Input Type: Basic Fault Designation: STATIC AIR TEMPERATURE FAULT 					
Probe element Excitation:	5 V = J1-25							
Temp Input (probe element):	(+) = J1-63 (-) = J1-44							
Ground	GND = J1-53							
			Note: Nominal 500 Ω Temperature Probe only. Resistance @ 0°C: 500Ω ± 0.6Ω Connection example: CIC Temperature Sensor, P/N 05257 (2 wire). Connect positive lead to both J1-25 and J1-63. Connect negative lead to both J1-44 and J1-53 (Chassis Ground). Other probes may have three contacts.					

Honeywell
MK XXII EGPWS Installation Manual

TABLE E 3.1.2-11: AIR DATA INPUT SELECT #11

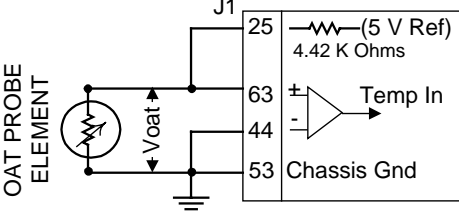
SIGNAL	CONNECTION		SUMMARY DATA		
Uncorrected Barometric Altitude	(+) = J1-62 (-) = J1-43		Format: DC with Validity Flag Input Type: Basic Fault Designation: BAROMETRIC ALTITUDE FAULT Validity: Barometric Alt Valid (+28V)		
Outside Air Temp Total Air Temperature Probe element Excitation: Temp Input (probe element): Ground	5 V = J1-25 (+) = J1-63 (-) = J1-44 GND = J1-53		Format: DC Input Type: Basic Fault Designation: STATIC AIR TEMPERATURE FAULT  Note: Nominal 500 Ω Temperature Probe only. Resistance @ 0°C: 500Ω ± 0.6Ω Connection example: CIC Temperature Sensor, P/N 05257 (2 wire). Connect positive lead to both J1-25 and J1-63. Connect negative lead to both J1-44 and J1-53 (Chassis Ground). Other probes may have three contacts.		
Computed Airspeed	No Connection	N/A	Substitute Ground Speed for Airspeed (airspeed is not available with this air data input).		
PIN FUNCTION	CONNECTION	PIN TYPE	CHANNEL DESIGNATION REFERENCE	Polarity/Configuration	References
Barometric Altitude Validity Discrete (+28V)	J1-9	Input	28V_DISC_08	>+17V = Valid < +4.4V = Invalid	6.6.19 4.2.7
Configuration Data			Type	Summary Data	
Derive Baro Altitude Rate			Analog	Baro Altitude Rate is derived using Uncorrected Barometric Altitude. Although the AZ-241 provides Baro rate, the EGPWS does not have an analog connection available.	

Honeywell
MK XXII EGPWS Installation Manual

TABLE E 3.1.2-12: AIR DATA INPUT SELECT #12

SIGNAL	CONNECTION		SUMMARY DATA		
Uncorrected Barometric Altitude	(+) = J1-62 (-) = J1-43		Format: DC with Validity Flag Input Type: Basic Fault Designation: BAROMETRIC ALTITUDE FAULT Validity: Barometric Alt Valid (+28V)		
Outside Air Temp	No Connection		Format: Internal Constant 25°C and Valid. Input Type: Basic Fault Designation: Static Air Temperature.		
Computed Airspeed	No Connection	N/A	Substitute Ground Speed for Airspeed (airspeed is not available with this air data input).		
PIN FUNCTION	CONNECTION	PIN TYPE	CHANNEL DESIGNATION REFERENCE	Polarity/Configuration	References
Barometric Altitude Validity Discrete (+28V)	J1-9	Input	28V_DISC_08	>+17V = Valid < +4.4V = Invalid	6.6.19 4.2.7
Configuration Data			Type	Summary Data	
Derive Baro Altitude Rate			Analog	Baro Altitude Rate is derived using Uncorrected Barometric Altitude. Although the AZ-800 provides Baro rate, the EGPWS does not have an analog connection available.	

E 5.3.3 CATEGORY 3, POSITION INPUT SELECT

The following table provides identification of the Position source signal. Each entry in the Position Input Type column has a corresponding table that provides detailed information on the configuration. For example, the details for Position Input Type #0 are found in Table E 3.1.3-0.

In this category, only the following Position signals are defined:

- Altitude
- Date
- Ground Speed
- Horizontal Figure of Merit (HFOM)
- Horizontal Integrity Limit
- Latitude Position
- Longitude Position
- Sensor Status
- True Track Angle
- Universal Time Correlation
- Vertical Figure of Merit (VFOM)

TABLE E 3.1.3: POSITION INPUT SELECT FOR EGPWS MKXXII

ID	Position Input Type (TableE 3.1.3-x)	Description	Effectivity	
			App.	Cfg.
0	0	GPS, ARINC 429 low speed, 743A format	-001	-001
1	1	GPS, ARINC 429 low speed, 743 format	-001	-001
2	2	GPS, Internal (RS-232 GPS-PXPRESS format)	-001	-001
3	3	GPS, External (RS-232 GPS-PXPRESS format)	-001	-001
4	4	GPS, ARINC 429 high speed, 743A format	-001	-001
5	5	GPS, ARINC 429 high speed, 743 format	-001	-001
255	6	Dual GPS, ARINC 429 high speed, 743 format	-003	-003

Note 1: The GPS Altitude Reference in Category 7, Options 1 Select must be properly applied for the appropriate GPS Position type. At the time of release of this document, all GPS sources except the Universal GPS1000 based systems are of

Honeywell
MK XXII EGPWS Installation Manual

MSL type. The Universal GPS1000 based GPS sources are of WGS-84 type. If the internal GPS source (ID=2) is defined, the GPS altitude reference in Category 7 must be MSL.

Note 2: Universal GPS 1000 does not calculate VFOM and HFOM correctly which makes it an unacceptable position source for helicopters.

TABLE E 3.1.3-0: POSITION INPUT TYPE 0 (LOW SPEED ARINC 743A GPS)

CHANNEL 429RX_4	CONNECT TO: GPS (Low Speed) per ARINC 743A-2	Fault Designation: GPS BUS Bus Type: Basic					
		Label	Sig. Bits	Range	Signal Type	Resolution	*Rate (ms)
A = J2-25 B = J2-8	Data						
	Latitude - Normal	110	20	±180 Degrees	Basic	0.00017166137695	1000
	Longitude - Normal	111	20	±180 Degrees	Basic	0.00017166137695	1000
	GPS Hor. Int. Limit	130	17	16 nm	Basic	0.00012207	1000
	Altitude	076	20	±131,072 FT	Basic	0.125	1000
	VFOM	136	18	32768 ft	Basic	0.125	1000
	HFOM	247	18	16 nm	Basic	0.000061035	1000
	Ground Speed	112	15	±4096 Knots	Basic	0.125	1000
	True Track Angle	103	15	±180 Degrees	Basic	0.0054931640625	1000
	Sensor Status	273	19	Discrete Wd	Basic	n/a	1000
	**UTC	125	19	Discrete Wd	Basic	0.1 min	1000
	**Date	260	19	Discrete Wd	Basic	1 day	1000
	**This label is not required. Data used if present						

*Slowest acceptable update rate in milliseconds.

TABLE E 3.1.3-1: POSITION INPUT TYPE 1 (LOW SPEED ARINC 743 GPS)

CHANNEL 429RX_4	CONNECT TO: GPS (Low Speed) per ARINC 743	Fault Designation: GPS BUS Bus Type: Basic					
		Label	Sig. Bits	Range	Signal Type	Resolution	*Rate (ms)
A = J2-25 B = J2-8	Data						
	Latitude - Normal	110	20	±180 Degrees	Basic	0.00017166137695	1000
	Longitude - Normal	111	20	±180 Degrees	Basic	0.00017166137695	1000
	GPS Hor. Int. Limit	130	17	16 nm	Basic	0.00012207	1000
	Altitude	076	20	±131,072 FT	Basic	0.125	1000
	VFOM	136	15	1024 meters	Basic	0.03125	1000
	HFOM	247	15	1024 meters	Basic	0.03125	1000
	Ground Speed	112	15	±4096 Knots	Basic	0.125	1000
	True Track Angle	103	15	±180 Degrees	Basic	0.0054931640625	1000
	Sensor Status	273	19	Discrete Wd	Basic	n/a	1000
	**UTC	125	19	Discrete Wd	Basic	0.1 min	1000
	**Date	260	19	Discrete Wd	Basic	1 day	1000
	**This label is not required. Data used if present						

*Slowest acceptable update rate in milliseconds.

Honeywell
MK XXII EGPWS Installation Manual

TABLE E 3.1.3-2: POSITION INPUT TYPE 2 (INTERNAL RS-232 GPS)

CHANNEL GPS_RXA GPS_TXA	Internal GPS [XPGPS_Int] = 1 (9600 baud)	Fault Designation: INTERNAL GPS Bus Type: Basic						
		ID/byte	Sig. Bits	Range	Signal Type	Resolution	*Rate (ms)	
Internal	Data							
	Latitude	15/1-4	32	±180 Degrees	Basic	real single-precision	1000	
	Longitude	15/5-8	32	±180 Degrees	Basic	real single-precision	1000	
	HP Error	15/9-12	32	meters	Basic	real single-precision	1000	
	Altitude	16/1-4	32	meters	Basic	real single-precision	1000	
	VP Error	16/5-8	32	meters	Basic	real single-precision	1000	
	Ground Speed	17/1-4	32	meters/sec	Basic	real single-precision	1000	
	True Track Angle	17/5-8	32	360 Degrees	Basic	real single-precision	1000	
	GPS State	1C/0	8	Discrete Wd	Basic	n/a	1000	
	Integrity State	1C/1	8	Discrete Wd	Basic	n/a	1000	
	Error Status	1C/6-7	8	Discrete Wd	Basic	n/a	1000	

* Slowest acceptable update rate in milliseconds.

Note: "MSL" reference must be selected when an internal GPS is utilized. Refer to Table 5.3.7

TABLE E 3.1.3-3: POSITION INPUT TYPE 3 (EXTERNAL RS232 GPS, PXPRESS FORMAT)

CHANNEL GPS_RXA GPS_TXA	Internal GPS [XPGPS_Int] = 0 (9600 baud)	Fault Designation: GPS BUS Bus Type: Basic						
		ID/byte	Sig. Bits	Range	Signal Type	Resolution	*Rate (ms)	
External J2-28 (cm) J2-45 (Tx) J2-29 (Rx)	Data							
	Latitude	15/1-4	32	±180 Degrees	Basic	real single-precision	1000	
	Longitude	15/5-8	32	±180 Degrees	Basic	real single-precision	1000	
	HP Error	15/9-12	32	meters	Basic	real single-precision	1000	
	Altitude	16/1-4	32	meters	Basic	real single-precision	1000	
	VP Error	16/5-8	32	meters	Basic	real single-precision	1000	
	Ground Speed	17/1-4	32	meters/sec	Basic	real single-precision	1000	
	True Track Angle	17/5-8	32	360 Degrees	Basic	real single-precision	1000	
	GPS State	1C/0	8	Discrete Wd	Basic	n/a	1000	
	Integrity State	1C/1	8	Discrete Wd	Basic	n/a	1000	
	Error Status	1C/6-7	8	Discrete Wd	Basic	n/a	1000	

* Slowest acceptable update rate in milliseconds.

TABLE E 3.1.3-4: POSITION INPUT TYPE 4 (HIGH SPEED ARINC 743A GPS)

CHANNEL 429RX_4	CONNECT TO: GPS (High Speed) per ARINC 743A-2	Fault Designation: GPS BUS Bus Type: Basic						
		Label	Sig. Bits	Range	Signal Type	Resolution	*Rate (ms)	
A = J2-25 B = J2-8	Data							
	Latitude - Normal	110	20	±180 Degrees	Basic	0.00017166137695	1000	
	Longitude - Normal	111	20	±180 Degrees	Basic	0.00017166137695	1000	
	GPS Hor. Int. Limit	130	17	16 nm	Basic	0.00012207	1000	
	Altitude	076	20	±131,072 FT	Basic	0.125	1000	
	VFOM	136	18	32768 ft	Basic	0.125	1000	
	HFOM	247	18	16 nm	Basic	0.000061035	1000	
	Ground Speed	112	15	±4096 Knots	Basic	0.125	1000	
	True Track Angle	103	15	±180 Degrees	Basic	0.0054931640625	1000	
	Sensor Status	273	19	Discrete Wd	Basic	n/a	1000	
	**UTC	125	19	Discrete Wd	Basic	0.1 min	1000	
	**Date	260	19	Discrete Wd	Basic	1 day	1000	
	**This label is not required. Data used if present							

*Slowest acceptable update rate in milliseconds.

Honeywell
MK XXII EGPWS Installation Manual

TABLE E 3.1.3-5: POSITION INPUT TYPE 5 (HIGH SPEED ARINC 743 GPS)

CHANNEL 429RX_4	CONNECT TO: GPS (High Speed) per ARINC 743	Fault Designation: GPS BUS						
		Bus Type: Basic						
A = J2-25 B = J2-8	Data	Label	Sig. Bits	Range	Signal Type	Resolution	*Rate (ms)	
	Latitude - Normal	110	20	±180 Degrees	Basic	0.00017166137695	1000	
	Longitude - Normal	111	20	±180 Degrees	Basic	0.00017166137695	1000	
	GPS Hor. Int. Limit	130	17	16 nm	Basic	0.00012207	1000	
	Altitude	076	20	±131,072 FT	Basic	0.125	1000	
	VFOM	136	15	1024 meters	Basic	0.03125	1000	
	HFOM	247	15	1024 meters	Basic	0.03125	1000	
	Ground Speed	112	15	±4096 Knots	Basic	0.125	1000	
	True Track Angle	103	15	±180 Degrees	Basic	0.0054931640625	1000	
	Sensor Status	273	19	Discrete Wd	Basic	n/a	1000	
	**UTC	125	19	Discrete Wd	Basic	0.1 min	1000	
	**Date	260	19	Discrete Wd	Basic	1 day	1000	
	**This label is not required. Data used if present							

*Slowest acceptable update rate in milliseconds.

TABLE E3.1.3-255: POSITION INPUT TYPE 255 (DUAL HIGH SPEED ARINC 743A GPS)

CHANNEL 429RX_4	CONNECT TO: GPS #1 (High Speed) per ARINC 743A-2	Fault Designation: GPS BUS 1						
		Bus Type: Basic						
A = J2-25 B = J2-8	Data	Label	Sig. Bits	Range	Signal Type	Resolution	*Rate (ms)	
	Latitude - Normal	110	20	±180 Degrees	Basic	0.00017166137695	1000	
	Longitude - Normal	111	20	±180 Degrees	Basic	0.00017166137695	1000	
	GPS Hor. Int. Limit	130	17	16 nm	Basic	0.00012207	1000	
	Altitude	076	20	±131,072 FT	Basic	0.125	1000	
	VFOM	136	18	32768 ft	Basic	0.125	1000	
	HFOM	247	18	16 nm	Basic	0.000061035	1000	
	Ground Speed	112	15	±4096 Knots	Basic	0.125	1000	
	True Track Angle	103	15	±180 Degrees	Basic	0.0054931640625	1000	
	Sensor Status	273	19	Discrete Wd	Basic	n/a	1000	
	**UTC	125	19	Discrete Wd	Basic	0.1 min	1000	
	**Date	260	19	Discrete Wd	Basic	1 day	1000	
	**This label is not required. Data used if present							

CHANNEL 429RX_7	CONNECT TO: GPS #2 (High Speed) per ARINC 743A-2	Fault Designation: GPS BUS 2						
		Bus Type: Basic						
A = J2-23 B = J2-6	Data	Label	Sig. Bits	Range	Signal Type	Resolution	*Rate (ms)	
	Latitude - Normal	110	20	±180 Degrees	Basic	0.00017166137695	1000	
	Longitude - Normal	111	20	±180 Degrees	Basic	0.00017166137695	1000	
	GPS Hor. Int. Limit	130	17	16 nm	Basic	0.00012207	1000	
	Altitude	076	20	±131,072 FT	Basic	0.125	1000	
	VFOM	136	18	32768 ft	Basic	0.125	1000	
	HFOM	247	18	16 nm	Basic	0.000061035	1000	
	Ground Speed	112	15	±4096 Knots	Basic	0.125	1000	
	True Track Angle	103	15	±180 Degrees	Basic	0.0054931640625	1000	
	Sensor Status	273	19	Discrete Wd	Basic	n/a	1000	
	**UTC	125	19	Discrete Wd	Basic	0.1 min	1000	
	**Date	260	19	Discrete Wd	Basic	1 day	1000	
	**This label is not required. Data used if present							

*Slowest acceptable update rate in milliseconds.

Note: This configuration may not be selected if an AHRS configuration is required for Attitude and Heading information (refer to Category 10 type 1 and Category 11 type 1), due to the conflict with Channel 429RX-7.

Honeywell
MK XXII EGPWS Installation Manual

E 5.3.4 CATEGORY 4, ALTITUDE CALLOUTS

The following table provides identification of the Altitude Callouts Menu. Each entry in the ID column corresponds to a particular menu selection.

The Altitude Callouts menu consists of standard callout options and Autorotation Mode reversion callout options. ID's 0 through 127 consist of standard callouts while ID's 128 through 255 include standard callouts and reversion to a set of Autorotation callouts. Selecting ID 0 – 8 will result in the callouts listed being enunciated whether the aircraft is in autorotation or not. Selecting ID 128 – 137 will result in the identified standard callouts if the aircraft is not in autorotation and the autorotation callouts listed if the aircraft is in autorotation. The Autorotation Mode is defined by logic within the EGPWC for helicopter types identified in Category 1.

Smart Callout activation (TRUE) is reflected by a “500” callout being spoken at the end of the selected callout menu sequence in the Long Level 1 Self-Test. In addition, the Callout menu ID number and the “Smart Callout Selected” configuration message, will both be given during level 3 Self-Test and in the RS232 Present Status display.

TABLE E 3.1.4: ALTITUDE CALLOUTS FOR EGPWS MKXXII

ID	MENU	Autorotation ³ Callout Enable	Smart Callout Selected	Effectivity	
				App.	Cfg.
0	MINIMUMS-MINIMUMS, “Smart 500”, 200, 100, 50, 40, 30, 20 ,10	False	True	-001	-001
1	MINIMUMS-MINIMUMS, “Smart 500”, 200	False	True	-001	-001
2	MINIMUMS-MINIMUMS, “Smart 500”, 100, 50, 40, 30, 20,10	False	True	-001	-001
3	MINIMUMS-MINIMUMS, “Smart 500”	False	True	-001	-001
4	MINIMUMS-MINIMUMS, 200, 100, 50, 40, 30, 20 ,10	False	False	-001	-001
5	MINIMUMS-MINIMUMS, 200	False	False	-001	-001
6	MINIMUMS-MINIMUMS, 100, 50, 40, 30, 20 ,10	False	False	-001	-001
8	MINIMUMS-MINIMUMS	False	False	-001	-001
128	MINIMUMS-MINIMUMS, “Smart 500”, 200, 100, 50, 40, 30, 20 ,10	True	True ⁴	-003	-003
129	MINIMUMS-MINIMUMS, “Smart 500”, 200	True	True ⁴	-003	-003
130	MINIMUMS-MINIMUMS, “Smart 500”, 100, 50, 40, 30, 20 ,10	True	True ⁴	-003	-003
131	MINIMUMS-MINIMUMS, “Smart 500”	True	True ⁴	-003	-003
132	MINIMUMS-MINIMUMS, 200, 100, 50, 40, 30, 20 ,10	True	False	-003	-003
133	MINIMUMS-MINIMUMS, 200	True	False	-003	-003
134	MINIMUMS-MINIMUMS, 100, 50, 40, 30, 20 ,10	True	False	-003	-003
135	MINIMUMS-MINIMUMS, 100	True	False	-006	-006
136	MINIMUMS-MINIMUMS, 200, 100	True	False	-006	-006
137	MINIMUMS-MINIMUMS	True	False	-006	-006

³ The AUTOROTATION callouts consists of: 200, 100 during Autorotation, if Autorotation Callout Enabled is True.

⁴ The Smart Callout function will not be given if in autorotation.

Honeywell
MK XXII EGPWS Installation Manual

Note: Selecting an Altitude Callout ID without a minimums callout can be accomplished by leaving the Decision Height input discrete open or connected to +28VDC.

Honeywell
MK XXII EGPWS Installation Manual

E 5.3.5 CATEGORY 5, AUDIO MENU SELECT

The following table provides identification of the Voice Menu type. Each entry in the Voice Menu column has a corresponding table that provides detailed information on the configuration. For example, the details for Voice Menu # are found in Table E 3.1.5-128.

TABLE E 3.1.5: AUDIO MENU TYPE

ID	Audio Menu Type (Table E 3.1.5.-x)	Description	Effectivity	
			App	Cfg.
128	128	Basic Helicopter Menu	-006	-006

TABLE E 3.1.5-128: AUDIO MENU TYPE 128 (BASIC HELICOPTER)

ALERT/WARNING CONDITION	AUDIO MENU	NOTES
MODE 1 PULL UP	PULL UP	1
MODE 2 PULL UP PREFACE	TERRAIN TERRAIN	1, 2
MODE 2 PULL UP	PULL UP	1
TERRAIN AWARENESS PREFACE	WARNING! TERRAIN	1, 2
TERRAIN AWARENESS WARNING	WARNING! TERRAIN	1, 3
OBSTACLE AWARENESS PREFACE	WARNING! OBSTACLE	1, 2
OBSTACLE AWARENESS WARNING	WARNING! OBSTACLE	1, 3
MODE 2 TERRAIN	TERRAIN	
MODE 6 MINIMUMS	SELECTED CALLOUTS (See 5.3.4)	
MODE 6 ALTITUDE	ALTITUDE ALTITUDE (See 5.3.4)	
TERRAIN AWARENESS CAUTION	CAUTION TERRAIN (PAUSE) CAUTION TERRAIN	4
OBSTACLE AWARENESS CAUTION	CAUTION OBSTACLE (PAUSE) CAUTION OBSTACLE	4
MODE 4 TOO LOW TERRAIN	TOO LOW TERRAIN	
TCF TOO LOW TERRAIN	TOO LOW TERRAIN	
MODE 6 ALTITUDE CALLOUTS	SELECTED CALLOUTS (See 5.3.4)	
MODE 4 TOO LOW GEAR	TOO LOW GEAR	
MODE 1 SINKRATE	SINKRATE Note: The basic warning is "SINKRATE (PAUSE) SINKRATE". However, if the Mode 1 Pullup curve is violated only a single "Sinkrate" may occur prior to the pull up voice.	5
MODE 3 DON'T SINK	DON'T SINK (PAUSE) DON'T SINK	
MODE 5 GLIDESLOPE	GLIDESLOPE	
MODE 6 APPROACHING DH	SELECTED CALLOUTS (See 5.3.4)	
MODE 6 BANK ANGLE	BANK ANGLE (PAUSE) BANK ANGLE, BANK ANGLE BANK ANGLE (AlliedSignal Algorithm at low altitudes)	
MODE 6 TAIL STRIKE	TAIL TOO LOW	
TA&D INVALID ALERT	BE ALERT TERRAIN INOP	

Note 1: These are the only voices that can interrupt.

Note 2: The preface voices will always be given prior to the warning voice.

Note 3: Voice message is continuous.

Note 4: Voice message will repeat every 10 seconds.

Note 5: Long Self-Test will only issue a single 'Sinkrate'.

Honeywell
MK XXII EGPWS Installation Manual

E 5.3.6 CATEGORY 6, TERRAIN DISPLAY SELECT

Section Overview

The following table (5.3.6) has an identification number (ID) associated with each Terrain Display configuration. Each of the ID rows has a group number for the *Display Configuration*, the *Input Control*. The *TA&D Pop Up Disable* function is defined by a Boolean. The ID groups will completely identify a particular Terrain Display Interface.

In this category the following signals are configured by the ID number:

Signal Name	Signal Type	Defined By
Terrain Display Bus:	KCPB* or ARINC	Display Configuration Group
Range Bus:	ARINC 429 or RS-422	Display Input Control Group
TA&D Alternate Pop Up	Boolean	Defined directly in Table

*KCPB is also known as AlliedSignal Picture Bus (ASPB)

TABLE E 3.1.6: TERRAIN DISPLAY SELECT FOR EGPWS MKXXII

ID E 3.1.6-x- x	TAD and TCF Disable	Application Notes	Type Effectivity
0	False	KC Picture Bus (KCPB) (Note 1)	-006
1	False	No Display TAD And TCF Enabled	-006
2	True	TA&D / TCF Disabled	-006
3	False	Collins ProLine II (4x4) (Note 3)	-006
4	False	Bendix PPI-4A/4B (Note 2)	-006
5	False	Collins ProLine II (5x6) (Note 3)	-006
6	False	Collins ProLine II (5x4,5x5) (Note 3)	-006
Reserved			
Reserved			
9	False	Non-Integrated EFIS 40/50 (Honeywell/Bendix)	-006
10	False	Integrated EFIS 40/50 (Honeywell/Bendix)	-006
12	False	Collins WXI-701/711, <u>without</u> Auto Range	-006
13	False	Integrated Honeywell P880/660/440 (WXPDP w/ SCI range)	-006
14	False	Bendix PPI-4A/4B <u>without</u> Auto Range (Note 2)	-006
15	False	Integrated Honeywell P880/660/440 (WXPDP w/ SCI range and aircraft symbol on overlay)	-006
16	False	Bendix, IN182A, IN812A, (RDR 2000)	-010
17	False	Bendix, IN842A, IN862A, (RDR 2100)	-010
18	False	KC Picture Bus (KCPB) w/o presentation of Terrain Awareness Corrected Altitude (Note 1, Note 7)	-010
235	False	Collins ProLine 4 (Non-Intergrated)	-011
236	False	Collins ProLine 4 (Intergrated)	-011
242	False	KC Picture Bus (KCPB) (Note 1, Note 6)	-006
246	False	Non-Integrated EFIS 10 (Bendix/Honeywell)	-006
250	False	Honeywell EDZ705 (5x5), EDZ756 (5x6) with DC-811 range push button control	-006
255	False	Honeywell SPZ8000 (w/SCI range) (Note 4)	-006

Note 1: For a description of the KCPB features implemented in a particular software release, see Appendix B: KCPB Phased Implementation in the EGPWS Interface Methodology document 060-4303-000.

Note 2: This configuration is applicable to RDR-4B with a mod that makes it capable of displaying blue.

Note 3: Refer to Rockwell Collins Service Information Letter, EFIS 84/85/86 SIL 2-99 Dated March 16/99 or later revision,

Honeywell
MK XXII EGPWS Installation Manual

for information describing the requirements to interface an EGPWS to the Collins Pro Line II system equipped with EFIS 84/85/86 Displays and WXR-350/840/700 or TWR-850 Weather Radar systems.

Note 4: This interface only supports the SG-810 and SG-811 SPZ-8000. This display is defined for the -001 & -003 releases but can cause periodic resets of the EGPWS due to an internal SCI range problem. The -001 & -003 release should not be used for this display.

Note 5: Peaks Enable is always true regardless of the selection from Category 7 Table 5.3.7.

Note 6: This configuration is applicable to the Aircraft Type 133 (MD900/902) only. It is the only display configuration supported for that Aircraft Type.

Note-7 With this configuration the EGPWC shall not overlay Terrain Awareness Corrected Altitude.

Honeywell
MK XXII EGPWS Installation Manual

Table E 3.1.6-0 KC Picture Bus
DISPLAY CONFIGURATION GROUP 0 (KC PICTURE BUS²)

Function	Value
Display Type	KC Picture Bus (KCPB)
Sweep Type	Curtain (Vertical or Horizontal scan)
Auto Pop Up	Category 7, Options Select Group #1
	TA&D Alternate Pop Up: False TA&D Alternate Pop Up: True
	Pop Up On Caution or Warning Never Pop Up
Peaks Mode (Elevations via overlay)	Category 7, Options Select Group #1
	Peaks Enable: False Peaks Enable: True
	Peaks Off Peaks On
Manual select	None (Display Control Selection)
Manual deselect	None (Display Control Selection)
Auto Range	Controlled by display response (if selected a 10 nm range will be used)
Moving Marker	None
Overlay Page	Controlled by display
Display bus type	KCPB
DISPLAY BUS #1 453TX_1	CONNECT TO:
A = J1-58 B = J1-59	Terrain Display data
DISPLAY BUS #2 453TX_2	CONNECT TO:
A = J1-56 B = J1-57	Terrain Display data

DISPLAY INPUT CONTROL GROUP 0

CHANNEL	CONNECT TO:		Fault Designation: KCPB BUS 1					
429_422RX_1	KCPB-IND 429 out (range)		Bus Type: Basic					
	Bus 1 (Low Speed)		Label	Sig. Bits	Range	Signal Type	Resolution	Rate (ms)
A = J2-37 B = J2-36	Data *Range Query/Continuous Response DSU Status Data (DSU only) *Key Press/Display Mode		271	11	0.5-1023.5NM	Basic	0.5	250
			011	Discrete	N/A	Basic	N/A	1000
			350	Discrete	N/A	Basic	N/A	1000
			012	Discrete	N/A	Basic	N/A	250
CHANNEL	CONNECT TO:		Fault Designation: KCPB BUS 2					
429RX_3	KCPB-IND 429 out (range)		Bus Type: Basic					
	Bus 2 (Low Speed)		Label	Sig. Bits	Range	Signal Type	Resolution	Rate (ms)
A = J2-41 B = J2-40	Data *Range Query/Continuous Response DSU Status Data (DSU only) *Key Press/Display Mode		271	11	0.5-1023.5NM	Basic	0.5	250
			011	Discrete	N/A	Basic	N/A	1000
			350	Discrete	N/A	Basic	N/A	1000
			012	Discrete	N/A	Basic	N/A	250

OUTPUT 429 BUS GROUP 0

Channel	Pins	Comments
429TX_1 (Low Speed)	A = J2-43 B = J2-42	Transmits (Section 7) Label sets: 7.1.1.x, 7.1.2.x, 7.1.3.x and 7.1.4.x
429TX_2	A = J2-26 B = J2-9	No Connection (No Data Output)

Integration notes:

- KCPB is also known as ASPB (AlliedSignal Picture Bus).
- Label 012 is optional. The current fault and fault history message "RANGE" for label 271 (Range) is not shown if Range Keys are requested on label 012 (Key Press/Display Mode).
- When interfacing to a single display controller configuration the bus must be connected to both EGPWS input channels. This prevents the EGPWS from reporting an external bus fault on the second channel.

Honeywell
MK XXII EGPWS Installation Manual

Table Table E 3.1.6-1 No Display – TAD and TCF Enabled

OUTPUT 429 BUS GROUP 0

Channel	Pins	Comments
429TX_1 (Low Speed)	A = J2-43 B = J2-42	Transmits (Section 7) Label sets: 7.1.1.x, 7.1.2.x, 7.1.3.x and 7.1.4.x
429TX_2	A = J2-26 B = J2-9	No Connection (No Data Output)

Table Table E 3.1.6-2 TA&D / TCF Disabled

OUTPUT 429 BUS GROUP 0

Channel	Pins	Comments
429TX_1 (Low Speed)	A = J2-43 B = J2-42	Transmits (Section 7) Label sets: 7.1.1.x, 7.1.2.x, 7.1.3.x and 7.1.4.x
429TX_2	A = J2-26 B = J2-9	No Connection (No Data Output)

Honeywell
MK XXII EGPWS Installation Manual

Table Table E 3.1.6-3 Collins ProLine II (4x4)

DISPLAY CONFIGURATION GROUP 6 (COLLINS PRO-LINE II, 4X4)

Function	Value	
Display Type	Collins Pro-Line II (4x4) Display	
Sweep Type	Standard with +/-60 degree limit	
Auto Pop Up	Category 7, Options Select Group #1	
	TA&D Alternate Pop Up: False	TA&D Alternate Pop Up: True
	Pop Up On Caution or Warning	Never Pop Up
Peaks Mode (Elevations via overlay)	Category 7, Options Select Group #1	
	Peaks Enabled: False	Peaks Enabled: True
	Peaks Off	Peaks On
Auto Range	No	
Moving Marker	No	
Overlay Page	Yes; "TERR" located on the left side of display. Peaks Elevations located on the upper left side of Terrain image.	
Display bus type	Standard ARINC 453	
DISPLAY BUS #1 453TX_1	CONNECT TO:	
A = J1-58 B = J1-59	Terrain Display data to switching relay/Symbol Generator	
DISPLAY BUS #2 453TX_2	CONNECT TO:	
A = J1-56 B = J1-57	Terrain Display data to switching relay/Symbol Generator	

DISPLAY INPUT CONTROL GROUP 1

CHANNEL	CONNECT TO:		Fault Designation: DISPLAY BUS 1					
429_422RX_1	WX-IND 429 out (range) Bus 1 (Low Speed)		Bus Type: Basic					
A = J2-37 B = J2-36	Data Range (Display Word 2)		Label	Sig. Bits	Range	Signal Type	Resolution	Rate (ms)
			271	Discrete	5-320NM	Basic	N/A	100
CHANNEL	CONNECT TO:		Fault Designation: DISPLAY BUS 2					
429RX_3	WX-IND 429 out (range) Bus 2 (Low Speed)		Bus Type: Basic					
A = J2-41 B = J2-40	Data Range (Display Word 2)		Label	Sig. Bits	Range	Signal Type	Resolution	Rate (ms)
			271	Discrete	5-320NM	Basic	N/A	100
CONN PIN #	REFERENCE NAME		PIN FUNCTION			Polarity/Configuration		
J1-32	GND_DISC_12		Display Select Discrete #1			Type 1 (Momentary) Gnd = Display Select Toggle <not> Gnd = Normal		
J1-31	GND_DISC_13		Display Select Discrete #2			Type 1 (Momentary) Gnd = Display Select Toggle <not> Gnd = Normal		

OUTPUT 429 BUS GROUP 0

Channel	Pins	Comments
429TX_1 (Low Speed)	A = J2-43 B = J2-42	Transmits (Section 7) Label sets: 7.1.1.x, 7.1.2.x, 7.1.3.x and 7.1.4.x
429TX_2	A = J2-26 B = J2-9	No Connection (No Data Output)

Integration note:

When interfacing to a single display controller configuration the bus must be connected to both EGPWS input channels. This prevents the EGPWS from reporting an external bus fault on the second channel.

Honeywell
MK XXII EGPWS Installation Manual

Table Table E 3.1.6-4 Bendix PPI-4A/4B

DISPLAY CONFIGURATION GROUP 1 (BENDIX RDR 4A/B PPI WITH MOD.)

Function	Value
Display Type	Bendix PPI-4A/4B (MAP-MODE)
Sweep Type	Standard
Auto Pop Up	Category 7, Options Select Group #1
	TA&D Alternate Pop Up: False TA&D Alternate Pop Up: True
	Pop Up On Caution or Warning Never Pop Up
Peaks Mode (Elevations via overlay)	Category 7, Options Select Group #1
	Peaks Enable: False Peaks Enable: True
	Peaks Off Peaks On
Manual select	Anytime
Manual deselect	Anytime
Auto Range	Yes 10NM
Moving Marker	No
Overlay Page	Without Peaks: "TERR" located in the lower right corner. With Peaks: Peaks numbers located in the lower right corner.
Display bus type	Standard ARINC 453
DISPLAY BUS #1 453TX_1	CONNECT TO:
A = J1-58 B = J1-59	Terrain Display data to switching relay/Symbol Generator
DISPLAY BUS #2 453TX_2	CONNECT TO:
A = J1-56 B = J1-57	Terrain Display data to switching relay/Symbol Generator

DISPLAY INPUT CONTROL GROUP 1

CHANNEL	CONNECT TO:		Fault Designation: DISPLAY BUS 1 Bus Type: Basic					
429_422RX_1	WX-IND 429 out (range) Bus 1 (Low Speed)		<u>Label</u>	<u>Sig. Bits</u>	<u>Range</u>	<u>Signal Type</u>	<u>Resolution</u>	<u>Rate (ms)</u>
A = J2-37 B = J2-36	Data Range (Display Word 2)		271	Discrete	5-320NM	Basic	N/A	100
429RX_3	WX-IND 429 out (range) Bus 2 (Low Speed)		Fault Designation: DISPLAY BUS 2 Bus Type: Basic					
A = J2-41 B = J2-40	Data Range (Display Word 2)		<u>Label</u>	<u>Sig. Bits</u>	<u>Range</u>	<u>Signal Type</u>	<u>Resolution</u>	<u>Rate (ms)</u>
			271	Discrete	5-320NM	Basic	N/A	100
CONN PIN #	REFERENCE NAME		PIN FUNCTION			Polarity/Configuration		
J1-32	GND_DISC_12		Display Select Discrete #1			Type 1 (Momentary) Gnd = Display Select Toggle <not> Gnd = Normal		
J1-31	GND_DISC_13		Display Select Discrete #2			Type 1 (Momentary) Gnd = Display Select Toggle <not> Gnd = Normal		

OUTPUT 429 BUS GROUP 0

Channel	Pins	Comments
429TX_1 (Low Speed)	A = J2-43 B = J2-42	Transmits (Section 7) Label sets: 7.1.1.x, 7.1.2.x, 7.1.3.x and 7.1.4.x
429TX_2	A = J2-26 B = J2-9	No Connection (No Data Output)

Integration note:

When interfacing to a single display controller configuration the bus must be connected to both EGPWS input channels. This prevents the EGPWS from reporting an external bus fault on the second channel.

Honeywell
MK XXII EGPWS Installation Manual

Table E 3.1.6-5 Collins ProLine II (5x6)
DISPLAY CONFIGURATION GROUP 2 (COLLINS PROLINE II, 5X6)

Function	Value
Display Type	Collins ProLine II (5x6)
Sweep Type	Standard with +/-60 degree limit
Auto Pop Up	Category 7, Options Select Group #1
	TA&D Alternate Pop Up: False TA&D Alternate Pop Up: True
	Pop Up On Caution or Warning Never Pop Up
Peaks Mode (Available as of -003)	Category 7, Options Select Group #1
	Peaks Enabled: False Peaks Enabled: True
	Peaks Off Peaks On
Manual select	Anytime
Manual deselect	Anytime
Auto Range	No
Moving Marker	No
Overlay Page	Yes; "TERR" is located on the right side of display. "TERR" and Peaks Elevations located on upper left side of Terrain image as of -003.
Display bus type	Standard ARINC 453
DISPLAY BUS #1 453TX_1	CONNECT TO:
A = J1-58 B = J1-59	Terrain Display data to switching relay/Symbol Generator
DISPLAY BUS #2 453TX_2	CONNECT TO:
A = J1-56 B = J1-57	Terrain Display data to switching relay/Symbol Generator

DISPLAY INPUT CONTROL GROUP 1

CHANNEL	CONNECT TO:		Fault Designation: DISPLAY BUS 1					
429_422RX_1	WX-IND 429 out (range) Bus 1 (Low Speed)		Bus Type: Basic					
A = J2-37 B = J2-36	Data Range (Display Word 2)		Label	Sig. Bits	Range	Signal Type	Resolution	Rate (ms)
			271	Discrete	5-320NM	Basic	N/A	100
CHANNEL	CONNECT TO:		Fault Designation: DISPLAY BUS 2					
429RX_3	WX-IND 429 out (range) Bus 2 (Low Speed)		Bus Type: Basic					
A = J2-41 B = J2-40	Data Range (Display Word 2)		Label	Sig. Bits	Range	Signal Type	Resolution	Rate (ms)
			271	Discrete	5-320NM	Basic	N/A	100
CONN PIN #	REFERENCE NAME		PIN FUNCTION			Polarity/Configuration		
J1-32	GND_DISC_12		Display Select Discrete #1			Type 1 (Momentary) Gnd = Display Select Toggle <not> Gnd = Normal		
J1-31	GND_DISC_13		Display Select Discrete #2			Type 1 (Momentary) Gnd = Display Select Toggle <not> Gnd = Normal		

OUTPUT 429 BUS GROUP 0

Channel	Pins	Comments
429TX_1 (Low Speed)	A = J2-43 B = J2-42	Transmits (Section 7) Label sets: 7.1.1.x, 7.1.2.x, 7.1.3.x and 7.1.4.x
429TX_2	A = J2-26 B = J2-9	No Connection (No Data Output)

Integration note:

When interfacing to a single display controller configuration the bus must be connected to both EGPWS input channels. This prevents the EGPWS from reporting an external bus fault on the second channel.

Honeywell
MK XXII EGPWS Installation Manual

Table E 3.1.6-6 Collins ProLine II (5x4,5x5)
DISPLAY CONFIGURATION GROUP 3 (COLLINS PROLINE II, 5X4, 5X5)

Function	Value
Display Type	Collins ProLine II (5x4, 5x5) Display
Sweep Type	Standard with +/-60 degree limit
Auto Pop Up	Category 7, Options Select Group #1
	TA&D Alternate Pop Up: False TA&D Alternate Pop Up: True
	Pop Up On Caution or Warning Never Pop Up
Peaks Mode (Available as of -003)	Category 7, Options Select Group #1
	Peaks Enabled: False Peaks Enabled: True
	Peaks Off Peaks On
Auto Range	No
Moving Marker	No
Overlay Page	Yes; "TERR" is located on the right side of display. "TERR" or Peaks Elevations located on upper left side of Terrain image as of -003.
Display bus type	Standard ARINC 453
DISPLAY BUS #1 453TX_1	CONNECT TO:
A = J1-58 B = J1-59	Terrain Display data to switching relay/Symbol Generator
DISPLAY BUS #2 453TX_2	CONNECT TO:
A = J1-56 B = J1-57	Terrain Display data to switching relay/Symbol Generator

DISPLAY INPUT CONTROL GROUP 1

CHANNEL	CONNECT TO:		Fault Designation: DISPLAY BUS 1					
429RX_1	WX-IND 429 out (range) Bus 1 (Low Speed)		Bus Type: Basic					
A = J2-37 B = J2-36	Data Range (Display Word 2)		Label	Sig. Bits	Range	Signal Type	Resolution	Rate (ms)
			271	Discrete	5-320NM	Basic	N/A	100
CHANNEL	CONNECT TO:		Fault Designation: DISPLAY BUS 2					
429RX_3	WX-IND 429 out (range) Bus 2 (Low Speed)		Bus Type: Basic					
A = J2-41 B = J2-40	Data Range (Display Word 2)		Label	Sig. Bits	Range	Signal Type	Resolution	Rate (ms)
			271	Discrete	5-320NM	Basic	N/A	100
CONN PIN #	REFERENCE NAME		PIN FUNCTION			Polarity/Configuration		
J1-32	GND_DISC_12		Display Select Discrete #1			Type 1 (Momentary) Gnd = Display Select Toggle <not> Gnd = Normal		
J1-31	GND_DISC_13		Display Select Discrete #2			Type 1 (Momentary) Gnd = Display Select Toggle <not> Gnd = Normal		

OUTPUT 429 BUS GROUP 0

Channel	Pins	Comments
429TX_1 (Low Speed)	A = J2-43 B = J2-42	Transmits (Section 7) Label sets: 7.1.1.x, 7.1.2.x, 7.1.3.x and 7.1.4.x
429TX_2	A = J2-26 B = J2-9	No Connection (No Data Output)

Integration note:

When interfacing to a single display controller configuration the bus must be connected to both EGPWS input channels. This prevents the EGPWS from reporting an external bus fault on the second channel.

Honeywell
MK XXII EGPWS Installation Manual

Table E 3.1.6-9 Non-Integrated EFIS 40/50 (Honeywell/Bendix)
DISPLAY CONFIGURATION GROUP 7 (NON-INTEGRATED EFIS 40/50)

Function	Value
Display Type	Bendix Non-Integrated EFIS 40/50
Sweep Type	Sweep range +/- 60 degrees
Auto Pop Up	Category 7, Options Select Group #1
	TA&D Alternate Pop Up: False TA&D Alternate Pop Up: True
	Pop Up when display is in the proper mode. Never Pop Up
Peaks Mode (Peaks Elevations are in Terrain Image, replacing "TERR")	Category 7, Options Select Group #1
	Peaks Enabled: False Peaks Enabled: True
	Peaks Off Peaks On
Manual select	Anytime WXR is on and display is in proper Mode
Manual deselect	Anytime
Auto Range	No
Moving Marker	No
Overlay Page	Yes; "TERR" at upper right corner of display.
Display bus type	Standard ARINC 453
DISPLAY BUS #1 453TX_1	CONNECT TO:
A = J1-58 B = J1-59	Terrain Display data to switching relay/Symbol Generator
DISPLAY BUS #2 453TX_2	CONNECT TO:
A = J1-56 B = J1-57	Terrain Display data to switching relay/Symbol Generator

DISPLAY INPUT CONTROL GROUP 2

CHANNEL	CONNECT TO:	Fault Designation: DISPLAY BUS 1 Bus Type: Basic						
429_422RX_1	WX-IND 429 out (range) Bus 1 (Low Speed)		<u>Label</u>	<u>Sig. Bits</u>	<u>Range</u>	<u>Signal Type</u>	<u>Resolution</u>	<u>Rate</u>
A = J2-37 B = J2-36	Data Mode (Display Word 1) Range (Display Word 2) Discrete Word (VP)		270	Discrete	Mode, Tilt, Gain	Basic	N/A	100 ms
			271	Discrete	5-320NM	Basic	N/A	100 ms
			273	Discrete	VP Mode, Bit 11	Basic	N/A	100 ms
CHANNEL	CONNECT TO:	Fault Designation: DISPLAY BUS 2 Bus Type: Basic						
429RX_3	WX-IND 429 out (range) Bus 2 (Low Speed)		<u>Label</u>	<u>Sig. Bits</u>	<u>Range</u>	<u>Signal Type</u>	<u>Resolution</u>	<u>Rate</u>
A = J2-41 B = J2-40	Data Mode (Display Word 1) Range (Display Word 2) Discrete Word (VP)		270	Discrete	Mode, Tilt, Gain	Basic	N/A	100 ms
			271	Discrete	5-320NM	Basic	N/A	100 ms
			273	Discrete	VP Mode, Bit 11	Basic	N/A	100 ms
CONN PIN #	REFERENCE NAME	PIN FUNCTION				Polarity/Configuration		
J1-32	GND_DISC_12	Display Select Discrete #1				Type 1 (Momentary) Gnd = Display Select Toggle <not> Gnd = Normal		
J1-31	GND_DISC_13	Display Select Discrete #2				Type 1 (Momentary) Gnd = Display Select Toggle <not> Gnd = Normal		

OUTPUT 429 BUS GROUP 0

Channel	Pins	Comments
429TX_1 (Low Speed)	A = J2-43 B = J2-42	Transmits (Section 7) Label sets: 7.1.1.x, 7.1.2.x, 7.1.3.x and 7.1.4.x
429TX_2	A = J2-26 B = J2-9	No Connection (No Data Output)

Integration note:

When interfacing to a single display controller configuration the bus must be connected to both EGPWS input channels. This prevents the EGPWS from reporting an external bus fault on the second channel.

Honeywell
MK XXII EGPWS Installation Manual

Table E 3.1.6-10 Integrated EFIS 40/50 (Honeywell/Bendix)

DISPLAY CONFIGURATION GROUP 8 (INTEGRATED EFIS 40/50)		
Function	Value	
Display Type	Bendix Integrated EFIS 40/50	
Sweep Type	Sweep range +/- 90 degrees	
Auto Pop Up	Category 7, Options Select Group #1	
	TA&D Alternate Pop Up: False	TA&D Alternate Pop Up: True
	Pop Up on Terrain Caution or Warning.	Never Pop Up
Peaks Mode	Peaks Always Enabled	
	The EFIS display supplies the Peak Elevations as stroked characters. The EFIS can be configured to place the Elevations on the bottom left or right side of the display.	
Manual select	Anytime	
Manual deselect	Anytime	
Auto Range	Yes, to 10 nm on Terrain Caution or Warning.	
Moving Marker	No	
Overlay Page	No, the display supplies a "TERR" mode annunciation.	
Display bus type	Standard ARINC 453	
DISPLAY BUS #1 453TX_1	CONNECT TO:	
A = J1-58 B = J1-59	Terrain Display data to switching relay/Symbol Generator	
DISPLAY BUS #2 453TX_2	CONNECT TO:	
A = J1-56 B = J1-57	Terrain Display data to switching relay/Symbol Generator	

DISPLAY INPUT CONTROL GROUP 2								
CHANNEL	CONNECT TO:	Fault Designation: DISPLAY BUS 1						
429_422RX_1	WX-IND 429 out (range) Bus 1 (Low Speed)	Bus Type: Basic						
A = J2-37 B = J2-36	Data Mode (Display Word 1) Range (Display Word 2) Discrete Word (VP)	<u>Label</u>	<u>Sig. Bits</u>	<u>Range</u>	<u>Signal Type</u>	<u>Resolution</u>	<u>Rate</u>	
		270	Discrete	Mode, Tilt, Gain	Basic	N/A	100 ms	
		271	Discrete	5-320NM	Basic	N/A	100 ms	
		273	Discrete	VP Mode, Bit 11	Basic	N/A	100 ms	
CHANNEL	CONNECT TO:	Fault Designation: DISPLAY BUS 2						
429RX_3	WX-IND 429 out (range) Bus 2 (Low Speed)	Bus Type: Basic						
A = J2-41 B = J2-40	Data Mode (Display Word 1) Range (Display Word 2) Discrete Word (VP)	<u>Label</u>	<u>Sig. Bits</u>	<u>Range</u>	<u>Signal Type</u>	<u>Resolution</u>	<u>Rate</u>	
		270	Discrete	Mode, Tilt, Gain	Basic	N/A	100 ms	
		271	Discrete	5-320NM	Basic	N/A	100 ms	
		273	Discrete	VP Mode, Bit 11	Basic	N/A	100 ms	
CONN PIN #	REFERENCE NAME	PIN FUNCTION			Polarity/Configuration			
J1-32	GND_DISC_12	Display Select Discrete #1			Type 1 (Momentary) Gnd = Display Select Toggle <not> Gnd = Normal			
J1-31	GND_DISC_13	Display Select Discrete #2			Type 1 (Momentary) Gnd = Display Select Toggle <not> Gnd = Normal			

OUTPUT 429 BUS GROUP 0		
Channel	Pins	Comments
429TX_1 (Low Speed)	A = J2-43 B = J2-42	Transmits (Section 7) Label sets: 7.1.1.x, 7.1.2.x, 7.1.3.x and 7.1.4.x
429TX_2	A = J2-26 B = J2-9	No Connection (No Data Output)

Integration note:

- Peaks Elevations are transmitted digitally to the display via Label 025 on the ARINC453 bus; they are then display as stroked charters on the bottom left or right of the display (depending on EFIS strapping).
- To Pop Up for a Terrain Caution or Warning it is necessary for the EFIS to receive two discrete signals from the EGPWS (one to indicate that Terrain is selected and one to indicate that selection was due to an alert). The EFIS needs to distinguish between manual selection and alert conditions so it will know when it should autorange. Both EFIS and EGPWS start to autorange on a Caution or Warning to minimize any latency problem displaying status during an alert.

Honeywell
MK XXII EGPWS Installation Manual

- When interfacing to a single display controller configuration the bus must be connected to both EGPWS input channels. This prevents the EGPWS from reporting an external bus fault on the second channel.

Honeywell
MK XXII EGPWS Installation Manual

Table E 3.1.6-12 Collins WXI-701/711, without Auto Range
DISPLAY CONFIGURATION GROUP 10 (COLLINS WXI 701/711 PPI, WITHOUT AUTO RANGE)

Function	Value
Display Type	Collins WXI-701/711 PPI
Sweep Type	Fan
Auto Pop Up	Category 7, Options Select Group #1
	TA&D Alternate Pop Up: False TA&D Alternate Pop Up: True
	Pop Up On Caution or Warning Never Pop Up
Peaks Mode	Category 7, Options Select Group #1
	Peaks Enable: False Peaks Enable: True
	Peaks Off Peaks On
Manual select	Anytime
Manual deselect	Anytime
Auto Range	No
Moving Marker	No
Overlay Page	Without Peaks: "TERR" located at the bottom left of display. With Peaks: Peaks numbers lower left.
Display bus type	Standard ARINC 453
DISPLAY BUS #1 453TX_1	CONNECT TO:
A = J1-58 B = J1-59	Terrain Display data to switching relay/Symbol Generator
DISPLAY BUS #2 453TX_2	CONNECT TO:
A = J1-56 B = J1-57	Terrain Display data to switching relay/Symbol Generator

DISPLAY INPUT CONTROL GROUP 1

CHANNEL	CONNECT TO:	Fault Designation:						
429_422RX_1	WX-IND 429 out (range) Bus 1 (Low Speed)	DISPLAY BUS 1	Bus Type: Basic					
A = J2-37 B = J2-36	Data Range (Display Word 2)	Label 271	Sig. Bits Discrete	Range 5-320NM	Signal Type Basic	Resolution N/A	Rate (ms) 100	
429RX_3	WX-IND 429 out (range) Bus 2 (Low Speed)	DISPLAY BUS 2	Bus Type: Basic					
A = J2-41 B = J2-40	Data Range (Display Word 2)	Label 271	Sig. Bits Discrete	Range 5-320NM	Signal Type Basic	Resolution N/A	Rate (ms) 100	
CONN PIN #	REFERENCE NAME	PIN FUNCTION			Polarity/Configuration			
J1-32	GND_DISC_12	Display Select Discrete #1			Type 1 (Momentary) Gnd = Display Select Toggle <not> Gnd = Normal			
J1-31	GND_DISC_13	Display Select Discrete #2			Type 1 (Momentary) Gnd = Display Select Toggle <not> Gnd = Normal			

OUTPUT 429 BUS GROUP 0

Channel	Pins	Comments
429TX_1 (Low Speed)	A = J2-43 B = J2-42	Transmits (Section 7) Label sets: 7.1.1.x, 7.1.2.x, 7.1.3.x and 7.1.4.x
429TX_2	A = J2-26 B = J2-9	No Connection (No Data Output)

Integration note:

- Left/Right shift keys on the display are not to be used when displaying terrain.
- When interfacing to a single display controller configuration the bus must be connected to both EGPWS input channels. This prevents the EGPWS from reporting an external bus fault on the second channel.

Honeywell
MK XXII EGPWS Installation Manual

Table E 3.1.6-13 Integrated Honeywell P880/660/440 (WXPDP w/ SCI range)

Display Configuration Group 11 (Honeywell Integrated P880/660/440).

Function	Value
Display Type	Honeywell Integrated P880/660/440 radar displays
Sweep Type	Honeywell
Auto Pop Up	Category 7, Options Select Group #1
	TA&D Alternate Pop Up: False
	TA&D Alternate Pop Up: True
	Pop Up On Caution or Warning
Peaks Mode	Category 7, Options Select Group #1
	Peaks Enable: False
	Peaks Enable: True
	Peaks Off
Manual select	Anytime
Manual deselect	Anytime
Auto Range	No
Moving Marker	Yes (across bottom of display)
Overlay Page	Yes, for Peaks Elevations only
Display bus type	Honeywell picture bus
TERRAIN DISPLAY BUS #1 453TX_1	CONNECT TO:
A = J1-58 B = J1-59	Terrain Display data to switching relay/Symbol Generator #1
TERRAIN DISPLAY BUS #2 453TX_2	CONNECT TO: Not supported for this display type

DISPLAY INPUT CONTROL GROUP 3

CHANNEL	CONNECT TO:	1.1.1.1.1.1 Fault Designation: DISPLAY BUS 1					
429_422RX_1	SCI Bus 1 (RS-422 - 12K baud)	Bus Type: Basic					
A = J2-36 B = J2-37	Data Range (Mode/Range Word)	Label	Sig. Bits	Range	Signal Type	Resolution	Rate (ms)
		80	4 Discrete	2000NM	Basic	N/A	100
CONN PIN #	REFERENCE NAME	PIN FUNCTION				Polarity/Configuration	
J1-32	GND_DISC_12	Display Select Discrete #1				Type 1 (Momentary) Gnd = Display Select Toggle <not> Gnd = Normal	

OUTPUT 429 BUS GROUP 0

Channel	Pins	Comments
429TX_1 (Low Speed)	A = J2-43 B = J2-42	Transmits (Section 7) Label sets: 7.1.1.x, 7.1.2.x, 7.1.3.x and 7.1.4.x
429TX_2	A = J2-26 B = J2-9	No Connection (No Data Output)

Integration note:

Honeywell
MK XXII EGPWS Installation Manual

Table E 3.1.6-14 Bendix PPI-4A/4B without Auto Range

DISPLAY CONFIGURATION GROUP 12 (BENDIX RDR 4A/B PPI WITHOUT AUTORANGE, WITH MOD.)

Function	Value
Display Type	Bendix PPI-4A/4B (MAP-MODE)
Sweep Type	Standard
Auto Pop Up	Category 7, Options Select Group #1
	TA&D Alternate Pop Up: False TA&D Alternate Pop Up: True
	Pop Up On Caution or Warning Never Pop Up
Peaks Mode (Elevations via overlay)	Category 7, Options Select Group #1
	Peaks Enable: False Peaks Enable: True
	Peaks Off Peaks On
Manual select	Anytime
Manual deselect	Anytime
Auto Range	No
Moving Marker	No
Overlay Page	Without Peaks: "TERR" located in the lower right corner. With Peaks: Peaks numbers located in the lower right corner.
Display bus type	Standard ARINC 453
TERRAIN DISPLAY BUS #1 453TX_1	CONNECT TO:
A = J1-58 B = J1-59	Terrain Display data to switching relay/Symbol Generator
TERRAIN DISPLAY BUS #2 453TX_2	CONNECT TO:
A = J1-56 B = J1-57	Terrain Display data to switching relay/Symbol Generator

DISPLAY INPUT CONTROL GROUP 1

CHANNEL	CONNECT TO:		Fault Designation: DISPLAY BUS 1 Bus Type: Basic					
429_422RX_1	WX-IND 429 out (range) Bus 1 (Low Speed)		<u>Label</u>	<u>Sig. Bits</u>	<u>Range</u>	<u>Signal Type</u>	<u>Resolution</u>	<u>Rate (ms)</u>
A = J2-37 B = J2-36	Data Range (Display Word 2)		271	Discrete	5-320NM	Basic	N/A	100
CHANNEL 429RX_3	CONNECT TO: WX-IND 429 out (range) Bus 2 (Low Speed)		Fault Designation: DISPLAY BUS 2 Bus Type: Basic					
A = J2-41 B = J2-40	Data Range (Display Word 2)		<u>Label</u>	<u>Sig. Bits</u>	<u>Range</u>	<u>Signal Type</u>	<u>Resolution</u>	<u>Rate (ms)</u>
			271	Discrete	5-320NM	Basic	N/A	100
CONN PIN #	REFERENCE NAME		PIN FUNCTION			Polarity/Configuration		
J1-32	GND_DISC_12		Display Select Discrete #1			Type 1 (Momentary) Gnd = Display Select Toggle <not> Gnd = Normal		
J1-31	GND_DISC_13		Display Select Discrete #2			Type 1 (Momentary) Gnd = Display Select Toggle <not> Gnd = Normal		

OUTPUT 429 BUS GROUP 0

Channel	Pins	Comments
429TX_1 (Low Speed)	A = J2-43 B = J2-42	Transmits (Section 7) Label sets: 7.1.1.x, 7.1.2.x, 7.1.3.x and 7.1.4.x
429TX_2	A = J2-26 B = J2-9	No Connection (No Data Output)

Integration note:

- When interfacing to a single display controller configuration the bus must be connected to both EGPWS input channels. This prevents the EGPWS from reporting an external bus fault on the second channel.

Honeywell
MK XXII EGPWS Installation Manual

Table E 3.1.6-15 Integrated Honeywell P880/660/440
(Honeywell Integrated P880/660/440 with A/C symbol)

Function	Value
Display Type	Honeywell Integrated P880/660/440 radar displays with A/C symbol
Sweep Type	Honeywell
Auto Pop Up	Category 7, Options Select Group #1
	TA&D Alternate Pop Up: False
	TA&D Alternate Pop Up: True
	Pop Up On Caution or Warning
Peaks Mode	Category 7, Options Select Group #1
	Peaks Enable: False
	Peaks Enable: True
	Peaks Off
	Peaks On
Manual select	Anytime
Manual deselect	Anytime
Auto Range	No
Moving Marker	Yes (across bottom of display)
Overlay Page	Yes, for Peaks Elevations only
Display bus type	Honeywell picture bus
TERRAIN DISPLAY BUS #1 453TX_1	CONNECT TO:
A = J1-58 B = J1-59	Terrain Display data to switching relay/Symbol Generator #1
TERRAIN DISPLAY BUS #2 453TX_2	CONNECT TO: Not supported for this display type

TABLE 5.3.6.2-3 DISPLAY INPUT CONTROL GROUP 3

CHANNEL	CONNECT TO:	1.1.1.1.2 Fault Designation: DISPLAY BUS 1						
429_422RX_1	SCI Bus 1 (RS-422 - 12K baud)	Bus Type: Basic						
A = J2-36 B = J2-37	Data Range (Mode/Range Word)	<u>Label</u> 80	<u>Sig. Bits</u> 4 Discrete	<u>Range</u> 2000NM	<u>Signal Type</u> Basic	<u>Resolution</u> N/A	<u>Rate (ms)</u> 100	
CONN PIN #	REFERENCE NAME	PIN FUNCTION				Polarity/Configuration		
J1-32	GND_DISC_12	Display Select Discrete #1				Type 1 (Momentary) Gnd = Display Select Toggle <not> Gnd = Normal		

TABLE 5.3.6.3-0 OUTPUT 429 BUS GROUP 0

TRACEABILITY

5.3.6.3-0:

Channel	Pins	Comments
429TX_1 (Low Speed)	A = J2-43 B = J2-42	Transmits (Section 7) Label sets: 7.1.1.x, 7.1.2.x, 7.1.3.x and 7.1.4.x
429TX_2	A = J2-26 B = J2-9	No Connection (No Data Output)

Integration Notes:

This display type overlays an inverted T aircraft symbol

Honeywell
MK XXII EGPWS Installation Manual

Table E 3.1.6-16 Bendix IN182A/IN812A Radar display (RDR 2000)

Function	Value	Reference section
Display Type	Bendix IN182A/IN812A color Radar Display (RDR-2000 radar system)	
Sweep Type	Sweep range +/- 50 degrees	
Auto Pop Up	Category 7, Options Select Group #1	
	TA&D Alternate Pop Up: False	TA&D Alternate Pop Up: True
	Pop Up when the display is in the proper mode.	Never Pop Up
Peaks Mode (Available -003)	Category 7, Options Select Group #1	
	Peaks Enabled: False	Peaks Enabled: True
	Peaks Off	Peaks On
Manual select	Anytime WXR is on and display is in proper Mode	
Manual deselect	Anytime	
Auto Range	No	
Moving Marker	No	
Overlay Page	Yes; "TERR" centered at top of display. "TERR" or Peaks Elevation located on upper right side of Terrain image as of -003.	
Display bus type	Standard ARINC 453	
TERRAIN DISPLAY BUS #1 453TX_1	CONNECT TO:	
A = J1-58 B = J1-59	Terrain Display data to switching relay/Symbol Generator	
TERRAIN DISPLAY BUS #2 453TX_2	CONNECT TO:	
A = J1-56 B = J1-57	Terrain Display data to switching relay/Symbol Generator	

Note :

- This config group is similar to config group 4 except warning inhibited message not seen on the overlay

Display Input Control Group 2

CHANNEL	CONNECT TO:		Fault Designation: DISPLAY BUS 1					
429_422RX_1	WX-IND 429 out (range) Bus 1 (Low Speed)		Bus Type: Basic					
	Data	Reference	Label	Sig. Bits	Range	Signal Type	Resolution	Rate
A = J2-37 B = J2-36	Mode (Display Word 1)	6.2.25	270	Discrete	Mode, Tilt, Gain	Basic	N/A	100 ms
	Range (Display Word 2)	6.2.18	271	Discrete	5-320NM	Basic	N/A	100 ms
	Discrete Word (VP)	6.2.26	273	Discrete	VP Mode, Bit 11	Basic	N/A	100 ms
CHANNEL	CONNECT TO:		Fault Designation: DISPLAY BUS 2					
429RX_3	WX-IND 429 out (range) Bus 2 (Low Speed)		Bus Type: Basic					
	Data	Reference	Label	Sig. Bits	Range	Signal Type	Resolution	Rate
A = J2-41 B = J2-40	Mode (Display Word 1)	6.2.25	270	Discrete	Mode, Tilt, Gain	Basic	N/A	100 ms
	Range (Display Word 2)	6.2.18	271	Discrete	5-320NM	Basic	N/A	100 ms
	Discrete Word (VP)	6.2.26	273	Discrete	VP Mode, Bit 11	Basic	N/A	100 ms
CONN PIN #	REFERENCE NAME		PIN FUNCTION			Polarity/Configuration		
J1-32	GND_DISC_12	Reference 4.2.7 6.6.18	Display Select Discrete #1			Type 1 (Momentary) Gnd = Display Select Toggle <not> Gnd = Normal		
J1-31	GND_DISC_13	Reference 4.2.7 6.6.19	Display Select Discrete #2			Type 1 (Momentary) Gnd = Display Select Toggle <not> Gnd = Normal		

* When interfacing to a single display controller configuration the bus must be connected to both EGPWS input channels. This prevents the EGPWS from reporting an external bus fault on the second channel.

Honeywell
MK XXII EGPWS Installation Manual

Output 429 Bus Group 0

Channel	Pins	Comments
429TX_1 (Low Speed)	A = J2-43 B = J2-42	Transmits (Section 7) Label sets: 7.1.1.x, 7.1.2.x, 7.1.3.x, 7.1.4.x, and 7.1.6.x ¹
429TX_2	A = J2-26 B = J2-9	No Connection (No Data Output)

Honeywell
MK XXII EGPWS Installation Manual

Table E 3.1.6-17 Bendix IN842A/IN862A Radar display (RDR 2100)

Function	Value	Reference section
Display Type	Bendix IN842A/IN862A color Radar Display (RDR-2100 radar system)	
Sweep Type	Sweep range +/- 60 degrees	
Auto Pop Up	Category 7, Options Select Group #1	
	TA&D Alternate Pop Up: False	TA&D Alternate Pop Up: True
	Pop Up when display is in the proper mode.	Never Pop Up
Peaks Mode (Available -003)	Category 7, Options Select Group #1	
	Peaks Enabled: False	Peaks Enabled: True
	Peaks Off	Peaks On
Manual select	Anytime WXR is on and display is in proper Mode	
Manual deselect	Anytime	
Auto Range	No	
Moving Marker	No	
Overlay Page	Yes; "TERR" centered at top of display. "TERR" or Peaks Elevation located on upper right side of Terrain image as of -003.	
Display bus type	Standard ARINC 453	
TERRAIN DISPLAY BUS #1 453TX_1	CONNECT TO:	
A = J1-58 B = J1-59	Terrain Display data to switching relay/Symbol Generator	
TERRAIN DISPLAY BUS #2 453TX_2	CONNECT TO:	
A = J1-56 B = J1-57	Terrain Display data to switching relay/Symbol Generator	

Note :

- This config group is similar to config group 5 except warning inhibited message not seen on the overlay

Honeywell
MK XXII EGPWS Installation Manual

Display Input Control Group 2

CHANNEL	CONNECT TO:		Fault Designation: DISPLAY BUS 1					
429_422RX_1	WX-IND 429 out (range) Bus 1 (Low Speed)		Bus Type: Basic					
A = J2-37 B = J2-36	Data Mode (Display Word 1) Range (Display Word 2) Discrete Word (VP)	<u>Reference</u> 6.2.25 6.2.18 6.2.26	<u>Label</u> 270 271 273	<u>Sig. Bits</u> Discrete Discrete Discrete	<u>Range</u> Mode, Tilt, Gain 5-320NM VP Mode, Bit 11	<u>Signal Type</u> Basic Basic Basic	<u>Resolution</u> N/A N/A N/A	<u>Rate</u> 100 ms 100 ms 100 ms
CHANNEL	CONNECT TO:		Fault Designation: DISPLAY BUS 2					
429RX_3	WX-IND 429 out (range) Bus 2 (Low Speed)		Bus Type: Basic					
A = J2-41 B = J2-40	Data Mode (Display Word 1) Range (Display Word 2) Discrete Word (VP)	<u>Reference</u> 6.2.25 6.2.18 6.2.26	<u>Label</u> 270 271 273	<u>Sig. Bits</u> Discrete Discrete Discrete	<u>Range</u> Mode, Tilt, Gain 5-320NM VP Mode, Bit 11	<u>Signal Type</u> Basic Basic Basic	<u>Resolution</u> N/A N/A N/A	<u>Rate</u> 100 ms 100 ms 100 ms
CONN PIN #	REFERENCE NAME		PIN FUNCTION			Polarity/Configuration		
J1-32	GND_DISC_12	<u>Reference</u> 4.2.7 6.6.18	Display Select Discrete #1			Type 1 (Momentary) Gnd = Display Select Toggle <not> Gnd = Normal		
J1-31	GND_DISC_13	<u>Reference</u> 4.2.7 6.6.19	Display Select Discrete #2			Type 1 (Momentary) Gnd = Display Select Toggle <not> Gnd = Normal		

* When interfacing to a single display controller configuration the bus must be connected to both EGPWS input channels. This prevents the EGPWS from reporting an external bus fault on the second channel.

Output 429 Bus Group 0

Channel	Pins	Comments
429TX_1 (Low Speed)	A = J2-43 B = J2-42	Transmits (Section 7) Label sets: 7.1.1.x, 7.1.2.x, 7.1.3.x, 7.1.4.x, and 7.1.6.x ¹
429TX_2	A = J2-26 B = J2-9	No Connection (No Data Output)

Honeywell
MK XXII EGPWS Installation Manual

Table E 3.1.6-18 KC Picture Bus w/o presentation of Terrain Awareness Corrected Altitude

Function	Value	Reference section
Display Type	KC Picture Bus (KCPB)	
Sweep Type	Curtain (Vertical or Horizontal scan)	
Auto Pop Up	Category 7, Options Select Group #1	
	TA&D Alternate Pop Up: False	TA&D Alternate Pop Up: True
	Pop Up On Caution or Warning	Never Pop Up
Peaks Mode (Elevations via overlay)	Category 7, Options Select Group #1	
	Peaks Enable: False	Peaks Enable: True
	Peaks Off	Peaks On
Manual select	None (Display Control Selection)	
Manual deselect	None (Display Control Selection)	
Auto Range	Controlled by display response (if selected a 10 nm range will be used)	
Moving Marker	None	
Overlay Page	Controlled by display	
Display bus type	KCPB	
TERRAIN DISPLAY BUS #1 453TX_1	CONNECT TO:	
A = J1-58 B = J1-59	Terrain Display data	
TERRAIN DISPLAY BUS #2 453TX_2	CONNECT TO:	
A = J1-56 B = J1-57	Terrain Display data	

Integration Notes:

- KCPB is also known as ASPB (AlliedSignal Picture Bus).
- This Display Group is configured by the Display using response labels on its ARINC 429 data bus.

Display Input Control Group 0

CHANNEL	CONNECT TO:		Fault Designation: KCPB BUS 1					
429_422RX_1	KCPB-IND 429 out (range) Bus 1 (Low Speed)		Bus Type: Basic					
	Data	Reference	Label	Sig. Bits	Range	Signal Type	Resolution	Rate (ms)
A = J2-37 B = J2-36	*Range	6.2.35	271	11	0.5-1023.5NM	Basic	0.5	250
	Query/Continuous Response	6.2.23	011	Discrete	N/A	Basic	N/A	1000
	DSU Status Data (DSU only)	6.2.36	350	Discrete	N/A	Basic	N/A	1000
	*Key Press/Display Mode	6.2.24	012	Discrete	N/A	Basic	N/A	250
CHANNEL	CONNECT TO:		Fault Designation: KCPB BUS 2					
429RX_3	KCPB-IND 429 out (range) Bus 2 (Low Speed)		Bus Type: Basic					
	Data	Reference	Label	Sig. Bits	Range	Signal Type	Resolution	Rate (ms)
A = J2-41 B = J2-40	*Range	6.2.35	271	11	0.5-1023.5NM	Basic	0.5	250
	Query/Continuous Response	6.2.23	011	Discrete	N/A	Basic	N/A	1000
	DSU Status Data (DSU only)	6.2.36	350	Discrete	N/A	Basic	N/A	1000
	*Key Press/Display Mode	6.2.24	012	Discrete	N/A	Basic	N/A	250

- * Label 012 is optional. The current fault and fault history message "RANGE" for label 271 (Range) is not shown if Range Keys are requested on label 012 (Key Press/Display Mode).
- * When interfacing to a single display controller configuration the bus must be connected to both EGPWS input channels. This prevents the EGPWS from reporting an external bus fault on the second channel.

Honeywell
MK XXII EGPWS Installation Manual

Output 429 Bus Group 0

Channel	Pins	Comments
429TX_1 (Low Speed)	A = J2-43 B = J2-42	Transmits (Section 7) Label sets: 7.1.1.x, 7.1.2.x, 7.1.3.x, 7.1.4.x, and 7.1.6.x ¹
429TX_2	A = J2-26 B = J2-9	No Connection (No Data Output)

Honeywell
MK XXII EGPWS Installation Manual

Table E 3.1.6-235 Display Configuration (Collins ProLine II, 5x6, and ProLine 4)

Function	Value	Reference section
Display Type	Collins ProLine II (5x6)	
Sweep Type	Standard with +/-60 degree limit	
Auto Pop Up	Category 7, Options Select Group #1	
	TA&D Alternate Pop Up: False	TA&D Alternate Pop Up: True
	Pop Up On Caution or Warning	Never Pop Up
Peaks Mode (Available as of -003)	Category 7, Options Select Group #1	
	Peaks Enabled: False	Peaks Enabled: True
	Peaks Off	Peaks On
Manual select	Anytime	
Manual deselect	Anytime	
Auto Range	No	
Moving Marker	No	
Overlay Page	Yes; "TERR" is located on the right side of display. "TERR" or Peaks Elevations located on upper left side of Terrain image as of -003.	
Display bus type	Standard ARINC 453	
TERRAIN DISPLAY BUS #1 453TX 1	CONNECT TO:	
A = J1-58 B = J1-59	Terrain Display data to switching relay/Symbol Generator	
TERRAIN DISPLAY BUS #2 453TX 2	CONNECT TO:	
A = J1-56 B = J1-57	Terrain Display data to switching relay/Symbol Generator	

Integration Notes:

1. Peaks Elevation numbers have been re-positioned to improve their presentation/visibility as of -010 release.

Display Input Control Group

CHANNEL 429_422RX_1	CONNECT TO: IOC #1 Bus (High Speed) Format: ARINC429		Fault Designation: IOC BUS 1					
			Bus Type: Basic					
A = J2-37 B = J2-36	Data Range (Mode/Range Word)		<u>Label</u> 155	<u>Sig. Bits</u> Discrete	<u>Range</u> 5-640NM	<u>Signal Type</u> Basic	<u>Resolution</u> N/A	<u>Rate (ms)</u> 50
CHANNEL 429RX_3	CONNECT TO: IOC #2 Bus (High Speed) Format: ARINC429		Fault Designation: IOC BUS 2					
			BUS TYPE: BASIC					
A = J2-41 B = J2-40	Data Range (Mode/Range Word)		<u>Label</u> 155	<u>Sig. Bits</u> Discrete	<u>Range</u> 5-640NM	<u>Signal Type</u> Basic	<u>Resolution</u> N/A	<u>Rate (ms)</u> 50

* When interfacing to a single display controller configuration the bus must be connected to both EGPWS input channels. This prevents the EGPWS from reporting an external bus fault on the second channel.

Output 429 Bus Group

Channel	Pins	Comments
429TX_1 (Low Speed)	A = J2-43 B = J2-42	Transmits
429TX_2	A = J2-26 B = J2-9	No Connection (No Data Output)

Honeywell
MK XXII EGPWS Installation Manual

Table E3.1.6-236 Display Configuration (Collins ProLine IV, 5x6)

Function	Value
Display Type	Collins ProLine IV (5x6)
Sweep Type	Standard with +/-60 degree limit
Auto Pop Up	Category 7, Options Select Group #1
	TA&D Alternate Pop Up: False
	TA&D Alternate Pop Up: True
	No Effect
	Pop Up Controlled by Display
Peaks Mode (Available as of -011)	Category 7, Options Select Group #1
	Peaks Enabled: False
	Peaks Enabled: True
	Peaks Off
	Peaks On
Pop Down	Never Automatically pop down
Manual select	Anytime
Manual deselect	Anytime
Auto Range	No
Moving Marker	No
Overlay Page	Yes; "TERR" is located on the right side of display. "TERR" and Peaks Elevations located on upper left side of Terrain image as of -011.
Display Priority	Standard
Display bus type	Standard ARINC 708
Terrain Mode Annunciation	Standard
TERRAIN DISPLAY BUS #1 453TX_1	CONNECT TO:
A = J1-58 B = J1-59	Terrain Display data to switching relay/Symbol Generator
TERRAIN DISPLAY BUS #2 453TX_2	CONNECT TO:
A = J1-56 B = J1-57	Terrain Display data to switching relay/Symbol Generator

Display Input Control

CHANNEL 429_422RX_1	CONNECT TO: IOC #1 Bus (High Speed) Format: ARINC429		Fault Designation: IOC BUS 1					
			Bus Type: Basic					
A = J2-37 B = J2-36	Data Range (Mode/Range Word)		<u>Label</u> 155	<u>Sig. Bits</u> Discrete	<u>Range</u> 5-640NM	<u>Signal Type</u> Basic	<u>Resolution</u> N/A	<u>Rate (ms)</u> 50
CHANNEL 429RX_3	CONNECT TO: IOC #2 Bus (High Speed) Format: ARINC429		Fault Designation: IOC BUS 2					
			BUS TYPE: BASIC					
A = J2-41 B = J2-40	Data Range (Mode/Range Word)		<u>Label</u> 155	<u>Sig. Bits</u> Discrete	<u>Range</u> 5-640NM	<u>Signal Type</u> Basic	<u>Resolution</u> N/A	<u>Rate (ms)</u> 50

* When interfacing to a single display controller configuration the bus must be connected to both EGPWS input channels. This prevents the EGPWS from reporting an external bus fault on the second channel.

Honeywell
MK XXII EGPWS Installation Manual

Output 429 Bus Group

Channel	Pins	Comments
429TX_1 (Low Speed)	A = J2-43 B = J2-42	Transmits (Section 7) Label sets: 7.1.1.x, 7.1.2.x, 7.1.3.x, 7.1.4.x, and 7.1.6.x ¹
429TX_2	A = J2-26 B = J2-9	No Connection (No Data Output)

Honeywell
MK XXII EGPWS Installation Manual

Table E 3.1.6-242 KC Picture Bus
Display Configuration Group 0 (KC Picture Bus¹)

Function	Value
Display Type	KC Picture Bus (KCPB)
Sweep Type	Curtain (Vertical or Horizontal scan)
Auto Pop Up	Category 7, Options Select Group #1
	TA&D Alternate Pop Up: False TA&D Alternate Pop Up: True
	Pop Up On Caution or Warning Never Pop Up
Peaks Mode (Elevations via overlay)	Category 7, Options Select Group #1
	Peaks Enable: False Peaks Enable: True
	Peaks Off Peaks On
Manual select	None (Display Control Selection)
Manual deselect	None (Display Control Selection)
Auto Range	Controlled by display response (if selected a 10 nm range will be used)
Moving Marker	None
Overlay Page	Controlled by display
Display bus type	KCPB
TERRAIN DISPLAY BUS #1 453TX_1	CONNECT TO:
A = J1-58 B = J1-59	Terrain Display data
TERRAIN DISPLAY BUS #2 453TX_2	CONNECT TO:
A = J1-56 B = J1-57	Terrain Display data

Display Input Control Group 245

CHANNEL	CONNECT TO:		Fault Designation: KCPB BUS 1 Bus Type: Basic					
429RX_8	KCPB-IND 429 out (range) Bus 1 (Low Speed)		<u>Label</u>	<u>Sig. Bits</u>	<u>Range</u>	<u>Signal Type</u>	<u>Resolution</u>	<u>Rate (ms)</u>
A = J2-24 B = J2-07	*Range Query/Continuous Response DSU Status Data (DSU only) *Key Press/Display Mode		271	11	0.5-1023.5NM	Basic	0.5	250
			011	Discrete	N/A	Basic	N/A	1000
			350	Discrete	N/A	Basic	N/A	1000
			012	Discrete	N/A	Basic	N/A	250
CHANNEL	CONNECT TO:		Fault Designation: KCPB BUS 2 Bus Type: Basic					
429RX_3	KCPB-IND 429 out (range) Bus 2 (Low Speed)		<u>Label</u>	<u>Sig. Bits</u>	<u>Range</u>	<u>Signal Type</u>	<u>Resolution</u>	<u>Rate (ms)</u>
A = J2-41 B = J2-40	*Range Query/Continuous Response DSU Status Data (DSU only) *Key Press/Display Mode		271	11	0.5-1023.5NM	Basic	0.5	250
			011	Discrete	N/A	Basic	N/A	1000
			350	Discrete	N/A	Basic	N/A	1000
			012	Discrete	N/A	Basic	N/A	250

OUTPUT 429 BUS GROUP 0

Channel	Pins	Comments
429TX_1 (Low Speed)	A = J2-43 B = J2-42	Transmits (Section 7) Label sets: 7.1.1.x, 7.1.2.x, 7.1.3.x and 7.1.4.x
429TX_2	A = J2-26 B = J2-9	No Connection (No Data Output)

Integration Notes:

- KCPB is also known as ASPB (AlliedSignal Picture Bus).
- This Display Group is configured by the Display using response labels on its ARINC 429 data bus.
- Label 012 is optional. The current fault and fault history message "RANGE" for label 271 (Range) is not shown if Range Keys are requested on label 012 (Key Press/Display Mode).
- When interfacing to a single display controller configuration the bus must be connected to both EGPWS input channels. This prevents the EGPWS from reporting an external bus fault on the second channel.

Honeywell
MK XXII EGPWS Installation Manual

Table E 3.1.6-246 Non-Integrated EFIS 10 (Bendix/Honeywell)
DISPLAY CONFIGURATION GROUP 246 (BENDIX EFIS 10 DISPLAY, EFS86 RADAR SYSTEM)

Function	Value
Display Type	Bendix EFIS 10
Sweep Type	Normal, Sweep range +/- 90 degrees
Auto Pop Up	Category 7, Options Select Group #1
	TA&D Alternate Pop Up: False TA&D Alternate Pop Up: True
	Pop Up On Terrain Caution or Warning. ¹ Never Pop Up
Peaks Mode	Category 7, Options Select Group #1
	Peaks Enable: False Peaks Enable: True
	Peaks Off Peaks On
Manual select	Anytime ¹
Manual deselect	Anytime ¹
Auto Range	No
Moving Marker	No
Overlay Page	Yes; Without Peaks: "TERR" is located at the bottom left of the display. With Peaks: Peaks numbers are located at the lower left of the display.
Display bus type	Standard ARINC 708/453
TERRAIN DISPLAY BUS #1 453TX_1	CONNECT TO:
A = J1-58 B = J1-59	Terrain Display data to switching relay/Symbol Generator #1
TERRAIN DISPLAY BUS #2 453TX_2	CONNECT TO:
A = J1-56 B = J1-57	Terrain Display data to switching relay/Symbol Generator #2

DISPLAY INPUT CONTROL GROUP 246

CHANNEL	CONNECT TO:		Fault Designation: DISPLAY BUS 1					
429_422RX_1	WX-IND 429 out (range)		Bus Type: Basic					
	Bus 1 (Low Speed)		Label	Sig. Bits	Range	Signal Type	Resolution	Rate
A = J2-37 B = J2-36	Data Mode (Display Word 1) Range (Display Word 2)		270	Discrete	Mode, Tilt, Gain	Basic	N/A	100 ms
			271	Discrete	5-320NM	Basic	N/A	100 ms
CHANNEL	CONNECT TO:		Fault Designation: DISPLAY BUS 2					
429RX_3	WX-IND 429 out (range)		Bus Type: Basic					
	Bus 2 (Low Speed)		Label	Sig. Bits	Range	Signal Type	Resolution	Rate
A = J2-41 B = J2-40	Data Mode (Display Word 1) Range (Display Word 2)		270	Discrete	Mode, Tilt, Gain	Basic	N/A	100 ms
			271	Discrete	5-320NM	Basic	N/A	100 ms
CONN PIN #	REFERENCE NAME		PIN FUNCTION			Polarity/Configuration		
J1-32	GND_DISC_12		Display Select Discrete #1			Type 1 (Momentary) Gnd = Display Select Toggle <not> Gnd = Normal		
J1-31	GND_DISC_13		Display Select Discrete #2			Type 1 (Momentary) Gnd = Display Select Toggle <not> Gnd = Normal		

OUTPUT 429 BUS GROUP 0

Channel	Pins	Comments
429TX_1 (Low Speed)	A = J2-43 B = J2-42	Transmits (Section 7) Label sets: 7.1.1.x, 7.1.2.x, 7.1.3.x and 7.1.4.x
429TX_2	A = J2-26 B = J2-9	No Connection (No Data Output)

Integration note:

- Either weather or a weather test pattern must be displayed before Terrain can be viewed. The white weather annunciation "WX" will still be present when terrain is displayed.
- When interfacing to a single display controller configuration the bus must be connected to both EGPWS input channels. This prevents the EGPWS from reporting an external bus fault on the second channel.

Honeywell
MK XXII EGPWS Installation Manual

Table E 3.1.6-250 Honeywell EDZ705 (5x5), EDZ756 (5x6) with DC-811 range push button control
DISPLAY CONFIGURATION GROUP 250 HONEYWELL SPZ8000, EDZ705 (5X5), EDZ756 (5X6), EDZ605, EDZ805, AND EDZ806)

Function	Value
Display Type	Honeywell (SPZ8000 new style - every fourth display line is blanked)
Sweep Type	Honeywell
Auto Pop Up	Category 7, Options Select Group #1
	TA&D Alternate Pop Up: False TA&D Alternate Pop Up: True
	Pop Up On Caution or Warning Never Pop Up
Peaks Mode	Category 7, Options Select Group #1
	Peaks Enable: False Peaks Enable: True
	Peaks Off Peaks On
Manual select	Controlled by display system
Manual deselect	Controlled by display system
Auto Range	Yes (10NM)
Moving Marker	Yes (Honeywell type)
Overlay Page	Yes for Peaks Elevations only.
Display bus type	Honeywell picture bus
TERRAIN DISPLAY BUS #1 453TX_1	CONNECT TO:
A = J1-58 B = J1-59	Terrain Display data to switching relay/Symbol Generator #1 and MFD left channel
TERRAIN DISPLAY BUS #2 453TX_2	CONNECT TO:
A = J1-56 B = J1-57	Terrain Display data to switching relay/Symbol Generator #2 and MFD right channel

DISPLAY INPUT CONTROL GROUP 251

CHANNEL	CONNECT TO:							
429_422RX_1	DC811 #1	1.1.1.1.3 Fault Designation: DISPLAY BUS 1						
		Bus Type: (RS-422 – 7.8125K baud)						
A = J2-36 B = J2-37	Data Range (Up/Down)	Label N/A	Sig. Bits	Range	Signal Type Basic	Resolution N/A	Rate (ms) 100	
422RX_2	CONNECT TO: DC811 #2	1.1.1.1.4 Fault Designation: DISPLAY BUS 2						
		BUS TYPE: (RS-422 – 7.8125K BAUD)						
A = J2-10 B = J2-11	Data Range (Up/Down)	Label N/A	Sig. Bits	Range	Signal Type Basic	Resolution N/A	Rate (ms) 100	

OUTPUT 429 BUS GROUP 0

Channel	Pins	Comments
429TX_1 (Low Speed)	A = J2-43 B = J2-42	Transmits (Section 7) Label sets: 7.1.1.x, 7.1.2.x, 7.1.3.x and 7.1.4.x
429TX_2	A = J2-26 B = J2-9	No Connection (No Data Output)

Integration Notes:

- The EGPWS ARINC 429 Output Bus must be connected to the display.
 - This display uses the following ARINC 429 labels from the EGPWS for annunciation:
The Terrain display will annunciate:
“TERR” in green or cyan (depending on the program) when the Terrain is selected and valid.
“TERR” in amber if Terrain is selected and any of the following conditions are TRUE:
 - The EGPWS ARINC 429 output bus is missing or labels 050 and 051 are absent or unreadable for 2 seconds.
 - EGPWS ARINC label 051 bit 13 = 0 (“Terrain Display Valid” bit FALSE)
 - EGPWS ARINC label 050 bit 17 = 1 (“Terrain Inhibit” bit TRUE)

Note - Per customer request for EDZ705 and EDZ756, the display does not go blank when Terrain is Inhibited, nor is an amber TERR presented. This change is part of the EFIS system

 - EGPWS ARINC labels are valid, but range in label 050 disagrees with range via SCI bus label 80 (Label 050 bits 11-14 contain the left display range and bits 15-18 contain the right).
- The display will be blanked when the amber “TERR” is present.
The Terrain display will Pop Up to Terrain mode as follows:
- If all the conditions indicated by for the amber “TERR” above are FALSE.

Honeywell
MK XXII EGPWS Installation Manual

- If the display is in normal MFD mode (not HSI backup, or SG backup) AND if Label 051 bit 11 transitions from 0 to 1 (rising edge), AND Checklist is not selected on the MFD, and TCAS Auto Pop Up is not occurring.
 - The display will change to Map mode.
 - The display will energize the Terrain selection relays.
 - The display will annunciate "TERR".
 - The display will change to the range indicated by the EGPWS ARINC 429 Label 050.
-
- When interfacing to a single display controller configuration the bus must be connected to both EGPWS input channels. This prevents the EGPWS from reporting an external bus fault on the second channel.
 - Note that the Channel **429_422RX_1** polarity is shown reversed from ARINC 429 application.

Honeywell
MK XXII EGPWS Installation Manual

Table E 3.1.6-255 Honeywell SPZ8000 (w/ SCI range)
Display Configuration Group 255 (Honeywell SPZ8000 older style)

Function	Value
Display Type	Honeywell (5x6) (SPZ8000) older style; does not blank every fourth weather radar display line. This interface supports SG-810 and SG-811 SPZ8000 systems only.
Sweep Type	Honeywell
Auto Pop Up	Category 7, Options Select Group #1
	TA&D Alternate Pop Up: False TA&D Alternate Pop Up: True
	Pop Up On Caution or Warning Never Pop Up
Peaks Mode (Elevations via overlay)	Category 7, Options Select Group #1
	Peaks Enable: False Peaks Enable: True
	Peaks Off Peaks On
Manual select	Controlled by SPZ8000 display system
Manual deselect	Controlled by SPZ8000 display system
Auto Range	Yes (10 NM)
Moving Marker	Yes (Honeywell type)
Overlay Page	Yes, for Peaks Elevations (located on lower right side)
Display bus type	Honeywell picture bus
TERRAIN DISPLAY BUS #1 453TX_1	CONNECT TO:
A = J1-58 B = J1-59	Terrain Display data to switching relay/Symbol Generator #1
TERRAIN DISPLAY BUS #2 453TX_2	CONNECT TO:
A = J1-56 B = J1-57	Terrain Display data to switching relay/Symbol Generator #2 (NOTE: Range setting always follows Display Bus #1).

Display Input Control Group 255

CHANNEL 429_422RX_1	CONNECT TO: SCI Bus 1 (RS-422 - 12K baud)	Fault Designation: DISPLAY BUS 1					
		Bus Type: Basic					
A = J2-36 B = J2-37	Data Range (Mode/Range Word)	<u>Label</u> 80	<u>Sig. Bits</u> 4 Discrete	<u>Range</u> 2000NM	<u>Signal Type</u> Basic	<u>Resolution</u> N/A	<u>Rate (ms)</u> 100

OUTPUT 429 BUS GROUP 0

Channel	Pins	Comments
429TX_1 (Low Speed)	A = J2-43 B = J2-42	Transmits (Section 7) Label sets: 7.1.1.x, 7.1.2.x, 7.1.3.x and 7.1.4.x
429TX_2	A = J2-26 B = J2-9	No Connection (No Data Output)

Integration Notes:

- The EGPWS ARINC 429 Output Bus must be connected to the SPZ8000 display.
- This display type may also be used for an integrated P880/660/440 display, but requires Auto Pop Up to be disabled and relay selection to be controlled directly from an alternate action switch (for new installations of P880/660/440 use ID 13).

Honeywell
MK XXII EGPWS Installation Manual

E 5.3.7 CATEGORY 7, OPTIONS 1 SELECT

The following table provides identification of the Options Select Group #1. Each entry in the ID column corresponds to a particular combination of TA&D Alternate Pop Up, Obstacle Awareness Enabled, Peaks Mode Enabled, Bank Angle Enable, Steep Approach Enabled, Flap / WOW Reversal and GPS Altitude Reference selection. Refer to section 7.5 for configuration messages that will be present for each option selected.

Note: Peaks Mode Enable is always True regardless of the option selected.

TABLE E 317: OPTIONS SELECT GROUP #1

ID	TA&D Alternate Pop Up	Peaks Mode Enabled ⁵	Obstacle Awareness Enabled	Bank Angle Enable	Weight On Wheels Reversal	GPS Altitude Reference ⁶	Effectivity	
							App	Cfg.
0	False	False	False	False	False	WGS-84	-001	-001
1	False	False	False	False	False	MSL	-001	-001
2	False	False	False	False	True	WGS-84	-001	-001
3	False	False	False	False	True	MSL	-001	-001
4	False	False	False	True	False	WGS-84	-001	-001
5	False	False	False	True	False	MSL	-001	-001
6	False	False	False	True	True	WGS-84	-001	-001
7	False	False	False	True	True	MSL	-001	-001
8	False	False	True	False	False	WGS-84	-001	-001
9	False	False	True	False	False	MSL	-001	-001
10	False	False	True	False	True	WGS-84	-001	-001
11	False	False	True	False	True	MSL	-001	-001
12	False	False	True	True	False	WGS-84	-001	-001
13	False	False	True	True	False	MSL	-001	-001
14	False	False	True	True	True	WGS-84	-001	-001
15	False	False	True	True	True	MSL	-001	-001
16	False	True	False	False	False	WGS-84	-001	-001
17	False	True	False	False	False	MSL	-001	-001
18	False	True	False	False	True	WGS-84	-001	-001
19	False	True	False	False	True	MSL	-001	-001
20	False	True	False	True	False	WGS-84	-001	-001
21	False	True	False	True	False	MSL	-001	-001
22	False	True	False	True	True	WGS-84	-001	-001
23	False	True	False	True	True	MSL	-001	-001
24	False	True	True	False	False	WGS-84	-001	-001
25	False	True	True	False	False	MSL	-001	-001
26	False	True	True	False	True	WGS-84	-001	-001
27	False	True	True	False	True	MSL	-001	-001
28	False	True	True	True	False	WGS-84	-001	-001
29	False	True	True	True	False	MSL	-001	-001
30	False	True	True	True	True	WGS-84	-001	-001
31	False	True	True	True	True	MSL	-001	-001
32	True	False	False	False	False	WGS-84	-001	-001
33	True	False	False	False	False	MSL	-001	-001

⁵ Enables PEAKS mode display if display supports

⁶ "MSL" reference must be selected when an internal GPS is utilized.

Honeywell
MK XXII EGPWS Installation Manual

ID	TA&D Alternate Pop Up	Peaks Mode Enabled ⁵	Obstacle Awareness Enabled	Bank Angle Enable	Weight On Wheels Reversal	GPS Altitude Reference ⁶	Effectivity	
							App	Cfg.
34	True	False	False	False	True	WGS-84	-001	-001
35	True	False	False	False	True	MSL	-001	-001
36	True	False	False	True	False	WGS-84	-001	-001
37	True	False	False	True	False	MSL	-001	-001
38	True	False	False	True	True	WGS-84	-001	-001
39	True	False	False	True	True	MSL	-001	-001
40	True	False	True	False	False	WGS-84	-001	-001
41	True	False	True	False	False	MSL	-001	-001
42	True	False	True	False	True	WGS-84	-001	-001
43	True	False	True	False	True	MSL	-001	-001
44	True	False	True	True	False	WGS-84	-001	-001
45	True	False	True	True	False	MSL	-001	-001
46	True	False	True	True	True	WGS-84	-001	-001
47	True	False	True	True	True	MSL	-001	-001
48	True	True	False	False	False	WGS-84	-001	-001
49	True	True	False	False	False	MSL	-001	-001
50	True	True	False	False	True	WGS-84	-001	-001
51	True	True	False	False	True	MSL	-001	-001
52	True	True	False	True	False	WGS-84	-001	-001
53	True	True	False	True	False	MSL	-001	-001
54	True	True	False	True	True	WGS-84	-001	-001
55	True	True	False	True	True	MSL	-001	-001
56	True	True	True	False	False	WGS-84	-001	-001
57	True	True	True	False	False	MSL	-001	-001
58	True	True	True	False	True	WGS-84	-001	-001
59	True	True	True	False	True	MSL	-001	-001
60	True	True	True	True	False	WGS-84	-001	-001
61	True	True	True	True	False	MSL	-001	-001
62	True	True	True	True	True	WGS-84	-001	-001
63	True	True	True	True	True	MSL	-001	-001

Honeywell
MK XXII EGPWS Installation Manual

E 5.3.8 CATEGORY 8, RADIO ALTITUDE INPUT SELECT

The following table provides identification of the Radio Altitude type. The entry in the Radio Altitude Type corresponds to a table that provides detailed information on the configuration. For example, the details for Radio Altitude Type #1 are found in Table 0-1. ARINC 552, ALT 55 and digital ARINC 429 compatible Radio Altimeters are supported. ALT 50 Radio Altimeters are not supported due to the maximum 2000-foot operation

CAUTION:
ALT 55 radio altimeters use an average altitude tracking technique that does not track the nearest terrain. This can produce errors up to 200 to 300 feet in high bank turns and mountainous terrain. This characteristic may degrade EGPWS performance for Modes 1 thru 6.

In this category, only the following signals are defined:

- Radio Altitude source selection, input scaling, and associated validities.

TABLE E 3.1.8: RADIO ALTITUDE INPUT SELECT FOR EGPWS MKXXII

ID	Radio Altitude Type (Table E 3.1.8-x)	Description	Effectivity	
			App.	Cfg.
0	0	Analog Radio Altitude (ARINC 552)	-001	-001
1	1	Analog (ALT 55)	-001	-001
2	2	Digital Radio Altitude (ARINC 429) (Note 2)	-001	-001
3	3	Analog Radio Altitude (RT-200/300)	-001	-001
4	4	Analog (KRA 405)	-003	-003
5	5	Analog (Alt 50)	-010	-010

Note 2: Digital Radio Altimeters can not be used on two engine Helicopters with Digital Torque.

TABLE E 3.1.8-0: RADIO ALTITUDE INPUT SELECT TYPE 0 (ARINC 552)

SIGNAL	CONNECTION		SUMMARY DATA		
Radio Altimeter #1	(+) = J1-64 (-) = J1-45		Format: ARINC 552 with Validity Flag Input Type: Basic Fault Designation: RADIO ALTIMETER FAULT Validity: Radio Altitude Valid Discrete #1 (+28V)		
PIN FUNCTION	CONNECTION	PIN TYPE	CHANNEL DESIGNATION REFERENCE	Polarity/Configuration	
Radio Altitude Validity Discrete #1 (+28V)	J1-29	Input	28V_DISC_07	>+17V = Valid <+4.4V = Invalid	
DH Discrete (Gnd)	J1-33	Input	GND_DISC_11	Gnd = Below DH <not> Gnd = Above DH	
CONFIGURATION DATA		Description		Value	
Out of Track Maximum		Pseudo altitude is only allowed to operate within these limits.		2800	
Out of Track Minimum				-20	
Pseudo Altitude Type		Selects parameters for pseudo altitude engage logic		3	
Field Enable Type		Selects pseudo altitude field elevation		2	

Honeywell
MK XXII EGPWS Installation Manual

TABLE E 3.1.8-1: RADIO ALTITUDE INPUT SELECT TYPE 1 (ALT 55)

SIGNAL	CONNECTION		SUMMARY DATA		
Radio Altimeter #1	(+) = J1-64 (-) = J1-45		Format: Alt 55 with Validity Flag Input Type: Basic Fault Designation: RADIO ALTIMETER FAULT Validity: Radio Altitude Valid Discrete #1 (+28V)		
PIN FUNCTION	CONNECTION	PIN TYPE	CHANNEL DESIGNATION REFERENCE	Polarity/Configuration	
Radio Altitude Validity Discrete #1 (+28V)	J1-29	Input	28V_DISC_07	>+17V = Valid <+4.4V = Invalid	
DH Discrete (Gnd)	J1-33	Input	GND_DISC_11	Gnd = Below DH <not> Gnd = Above DH	
CONFIGURATION DATA		Description		Value	
Out of Track Maximum		Pseudo altitude is only allowed to operate within these limits.		2800	
Out of Track Minimum				-20	
Pseudo Altitude Type		Selects parameters for pseudo altitude engage logic		4	
Field Enable Type		Selects pseudo altitude field elevation		2	

TABLE E 3.1.8-2: RADIO ALTITUDE INPUT SELECT TYPE 2 (ARINC 429)

CHANNEL 429RX_5	CONNECT TO: Left (#1) LRRR (Low Speed)		Fault Designation: RADIO ALTIMETER BUS Bus Type: Basic					
A = J2-21 B = J2-4	Data Radio Altitude		Label 164	Sig. Bits 16	Range ±8192 FT	Signal Type Basic	Resolution 0.125	Rate (ms) 25-50
PIN FUNCTION	CONNECTION	PIN TYPE	CHANNEL DESIGNATION REFERENCE	Polarity/Configuration				
DH Discrete (Gnd)	J1-33	Input	GND_DISC_11	Gnd = Below DH <not> Gnd = Above DH				

TABLE E 3.1.8-3: RADIO ALTITUDE INPUT SELECT TYPE 3 (RT-200/300)

SIGNAL	CONNECTION		SUMMARY DATA		
Radio Altimeter #1	(+) = J1-64 (-) = J1-45		Format: DC with Validity Flag (RT-200/300) Input Type: Basic Fault Designation: RADIO ALTIMETER FAULT Validity: Radio Altitude Valid Discrete #1 (+28V)		
PIN FUNCTION	CONNECTION	PIN TYPE	CHANNEL DESIGNATION REFERENCE	Polarity/Configuration	
Radio Altitude Validity Discrete #1 (+28V)	J1-29	Input	28V_DISC_07	>+17V = Valid <+4.4V = Invalid	
DH Discrete (Gnd)	J1-33	Input	GND_DISC_11	Gnd = Below DH <not> Gnd = Above DH	
CONFIGURATION DATA		Description		Value	
Out of Track Maximum		Pseudo altitude is only allowed to operate within these limits.		2800	
Out of Track Minimum				-20	
Pseudo Altitude Type		Selects parameters for pseudo altitude engage logic		3	
Field Enable Type		Selects pseudo altitude field elevation		2	

Honeywell
MK XXII EGPWS Installation Manual

TABLE E 3.1.8-4: RADIO ALTITUDE INPUT SELECT TYPE 4 (KRA 405)

SIGNAL	CONNECTION		SUMMARY DATA		
Radio Altimeter #1	(+) = J1-64 (-) = J1-45		Format: Alt 55 with Validity Flag Input Type: Basic Fault Designation: RADIO ALTIMETER FAULT Validity: Radio Altitude Valid Discrete #1 (+28V)		
PIN FUNCTION	CONNECTION	PIN TYPE	CHANNEL DESIGNATION REFERENCE	Polarity/Configuration	
Radio Altitude Validity Discrete #1 (+28V)	J1-29	Input	28V_DISC_07	>+17V = Valid <+4.4V = Invalid	
DH Discrete (Gnd)	J1-33	Input	GND_DISC_11	Gnd = Below DH <not> Gnd = Above DH	
CONFIGURATION DATA		Description		Value	
Out of Track Maximum		Pseudo altitude is only allowed to operate within these limits.		2800	
Out of Track Minimum				-20	
Pseudo Altitude Type		Selects parameters for pseudo altitude engage logic		3	
Field Enable Type		Selects pseudo altitude field elevation		2	

Table E 3.1.8-5: Radio Altitude Input Select Type 5 (ALT 50)

SIGNAL	CONNECTION	REFERENCE	SUMMARY DATA		
Radio Altimeter #1	(+) = J1-64 (-) = J1-45		Format: Alt 50 with Validity Flag Input Type: Basic Fault Designation: RADIO ALTIMETER FAULT Validity: Radio Altitude Valid Discrete #1 (+28V)		
PIN FUNCTION	CONNECTION	PIN TYPE	CHANNEL DESIGNATION REFERENCE	Polarity/Configuration	
Radio Altitude Validity Discrete #1 (+28V)	J1-29	Input	28V_DISC_07	>+17V = Valid <+4.4V = Invalid	
DH Discrete (Gnd)	J1-33	Input	GND_DISC_11	Gnd = Below DH <not> Gnd = Above DH	
CONFIGURATION DATA		Description		Value	
Out of Track Maximum		Pseudo altitude is only allowed to operate within these limits.		2100	
Out of Track Minimum				-20	
Pseudo Altitude Type		Selects parameters for pseudo altitude engage logic		4	
Field Enable Type		Selects pseudo altitude field elevation		2	

Honeywell
MK XXII EGPWS Installation Manual

E 5.3.9 CATEGORY 9, NAVIGATION INPUT SELECT

The following table provides identification of the Navigation type. The entry in the Navigation Type corresponds to a table that provides detailed information on the configuration. For example, the details for Navigation Type #1 are found in Table 0-1. In this category, only the following signals are defined:

- Glideslope source selection.
- Localizer source selection. (optional for digital only)

TABLE E 3.1.9: NAVIGATION INPUT SELECT FOR EGPWS MKXXII

ID	Navigation Inputs Select (Table E 3.1.9-x)	Description	Effectivity	
			App.	Cfg.
0	0	Analog Glideslope (ARINC 547) with +28V Validity Flag	-001	-001
1	1	Analog Glideslope (ARINC 547) with Low Level Validity	-001	-001
2	2	Digital Glideslope (ARINC 429)	-001	-001
3	3	Digital Glideslope and Localizer (ARINC 429)	-001	-001
4	4	Digital KN40 Glideslope and Localizer (ARINC 429)	-003	-003
5	5	Analog Glideslope/Localizer (ARINC 547) with +28V Validity Flags	-008	-008

TABLE E 3.1.9-0: NAVIGATION INPUTS SELECT 0

SIGNAL	CONNECTION		SUMMARY DATA		
Glideslope Deviation	(+) = J1-65 (-) = J1-46		Format: ARINC 547 with Validity Flag & ILS Select Input Type: Basic Fault Designation: GLIDESLOPE FAULT Validity: Glideslope Validity Discrete #1 (+28V)		
PIN FUNCTION	CONNECTION	PIN TYPE	CHANNEL DESIGNATION REFERENCE	Polarity/Configuration	
Glideslope Validity Discrete #1	J1-11	Input	28V_DISC_06	>+17V = Valid < +4.4V = Not Valid	
+28V ILS Tuned Discrete #1	J1-39	Input	28V_DISC_01	>+17V = ILS Tuned < +4.4V = ILS Not Tuned	
GND ILS Tuned Discrete #1	J1-20	Input	GND_DISC_01	Gnd = ILS Tuned <not> Gnd = ILS Not Tuned	

Honeywell
MK XXII EGPWS Installation Manual

TABLE E 3.1.9-1: NAVIGATION INPUTS SELECT 1

SIGNAL	CONNECTION		SUMMARY DATA		
Glideslope Deviation	(+) = J1-65 (-) = J1-46		Format: ARINC 547 with Low Level Validity & ILS Select Input Type: Basic Fault Designation: GLIDESLOPE FAULT Validity: Low Level Glideslope Deviation Validity		
Low Level Glideslope Deviation Validity	(+) = J1-30 (-) = J1-10		Format: DC Input Type: Basic Fault Designation: GLIDESLOPE LOW LEVEL VALIDITY FAULT > 0.145V = Valid (typical active range is 0.16V to 0.84V) <= 0.145V = Invalid		
PIN FUNCTION	CONNECTION	PIN TYPE	CHANNEL DESIGNATION REFERENCE	Polarity/Configuration	
+28V ILS Tuned Discrete #1	J1-39	Input	28V_DISC_01	>+17V = ILS Tuned < +4.4V = ILS Not Tuned	
GND ILS Tuned Discrete #1	J1-20	Input	GND_DISC_01	Gnd = ILS Tuned <not> Gnd = ILS Not Tuned	

TABLE E 3.1.9-2: NAVIGATION INPUTS SELECT 2

CHANNEL 429RX_6	CONNECT TO: ILS #1 (Low Speed)		Fault Designation: ILS BUS Bus Type: Basic					
A = J2-22 B = J2-5	Data Glideslope		Label	Sig. Bits	Range	Signal Type	Resolution	Rate (ms)
			174	12	±0.8 DDM	Basic	0.0001953125	33.3-66.6

TABLE E 3.1.9-3: NAVIGATION INPUTS SELECT 3

CHANNEL 429RX_6	CONNECT TO: ILS #1 (Low Speed)		Fault Designation: ILS BUS Bus Type: Basic					
A = J2-22 B = J2-5	Data Glideslope Localizer		Label	Sig. Bits	Range	Signal Type	Resolution	Rate (ms)
			174	12	±0.8 DDM	Basic	0.0001953125	33.3-66.6
			173	12	±0.4 DDM	Basic	0.00009765625	33.3-66.6

TABLE E 3.1.9-4: NAVIGATION INPUTS SELECT 4

CHANNEL 429RX_6	CONNECT TO: ILS #1 (Low Speed)		Fault Designation: ILS BUS Bus Type: Basic					
A = J2-22 B = J2-5	Data Glideslope Localizer ILS Select (VOR/ILS Freq)		Label	Sig. Bits	Range	Signal Type	Resolution	Rate (ms)
			174	12	±0.8 DDM	Basic	0.0001953125	33.3-66.6
			173	12	±0.4 DDM	Basic	0.00009765625	33.3-66.6
			034	Discrete	n/a	Basic	Bit 14 = ILS	167-333
Configuration Data			Type			Reference Section		
KN40 Nav Source			True			SRD 5.9.2.1.R61, 5.9.3.R41		

TABLE E 3.1.9-5: NAVIGATION INPUTS SELECT 5

SIGNAL	CONNECTION		SUMMARY DATA		
Glideslope Deviation	(+) = J1-65 (-) = J1-46		Format: ARINC 547 with Validity Super Flag & ILS Select Input Type: Basic Fault Designation: GLIDESLOPE FAULT Validity: Glideslope Validity Discrete #1 (+28V)		
Localizer Deviation	(+) = J1-30 (-) = J1-10		Format: ARINC 547 with Validity Flag & ILS Select Input Type: Basic Fault Designation: LOCALIZER FAULT Validity: Localizer Validity Discrete #1 (+28V)		
PIN FUNCTION	CONNECTION	PIN TYPE	CHANNEL DESIGNATION REFERENCE	Polarity/Configuration	
Localizer Validity Discrete #1	J1-48	Input	28V_DISC_11	>+17V = Valid < +4.4V = Not Valid	
Glideslope Validity Discrete #1	J1-11	Input	28V_DISC_06	>+17V = Valid < +4.4V = Not Valid	
+28V ILS Tuned Discrete #1	J1-39	Input	28V_DISC_01	>+17V = ILS Tuned < +4.4V = ILS Not Tuned	
GND ILS Tuned Discrete #1	J1-20	Input	GND_DISC_01	Gnd = ILS Tuned <not> Gnd = ILS Not Tuned	

Honeywell
MK XXII EGPWS Installation Manual

E 5.3.10 CATEGORY 10, ATTITUDE INPUT SELECT

The following table provides identification of the Roll Attitude Angle type. The entry in the Attitude Input Select corresponds to a table that provides detailed information on the configuration. For example, the details for Attitude Input Select #1 are found in 0-1.

In this category, only the following signals are defined:

- Roll Attitude
- Pitch Attitude
-
-

TABLE E 3.1.10: ATTITUDE INPUT SELECT FOR EGPWS MK XXII

ID	Attitude Input Select (Table 0-x)	Description	Effectivity	
			App.	Cfg.
0	0	Analog Roll (3-Wire Synchro) without validity	-001	-001
2	2	Analog Pitch and Roll (3-Wire Synchro)	-003	-003
4	4	Analog Roll(3-Wire Synchro) with validity (Note 1)	-003	-003
128	128	Digital Pitch, Roll, Pitch Rate and Roll Rate (High Speed ARINC 429) (Note 3)	-006	-006

Note 1: ID 4 may not be used with Category 13 (I/O Discrete Type) ID's 2, or 3. This is due to a conflict with the validity discrete. ID 0 may be used instead with the Validity discrete left unconnected. Also, ID 4 are intended to be used with helicopter types that do not have the tail strike functionality (currently the MD-900 only).

Note 2: ID 128 may only be used in conjunction with Category 11 (Magnetic Heading) ID 2.

TABLE E 3.1.10-0: ATTITUDE INPUT SELECT TYPE 0

SIGNAL	CONNECTION	SUMMARY DATA			
Roll Attitude	(X) = J1-1 (Y) = J1-21 (Z) = J1-2	Format: 3 Wire Synchro Input Type: Basic Fault Designation: ROLL FAULT Validity: None Reference: None			

TABLE E 3.1.10-2: ATTITUDE INPUT SELECT TYPE 2

SIGNAL	CONNECTION	SUMMARY DATA			
Roll Attitude	(X) = J1-1 (Y) = J1-21 (Z) = J1-2	Format: 3 Wire Synchro with Validity Flag Input Type: Basic Fault Designation: ROLL FAULT Validity: Attitude Validity Discrete #1 Reference: None			
Pitch Attitude	(X) = J1-5 (Y) = J1-7 (Z) = J1-6	Format: 3 Wire Synchro with Validity Flag Input Type: Basic Fault Designation: PITCH FAULT Validity: Attitude Validity Discrete #1 Reference: None			
PIN FUNCTION	CONNECTION	PIN TYPE	CHANNEL DESIGNATION REFERENCE	Polarity/Configuration	References
Attitude Validity Discrete #1	J1-68	Input	28V_DISC_12	>+17V = Valid <+4.4V = Invalid	6.6.24 4.2.7

Honeywell
MK XXII EGPWS Installation Manual

TABLE E 3.1.10-4: ATTITUDE INPUT SELECT TYPE 4

SIGNAL	CONNECTION		SUMMARY DATA		
Roll Attitude	(X) = J1-1 (Y) = J1-21 (Z) = J1-2		Format: 3 Wire Synchro with Validity Flag Input Type: Basic Fault Designation: ROLL FAULT Validity: Attitude Validity Discrete #1 Reference: None		
PIN FUNCTION	CONNECTION	PIN TYPE	CHANNEL DESIGNATION REFERENCE	Polarity/Configuration	Summary Data
Attitude Validity Discrete #1	J1-68	Input	28V_DISC_12	>+17V = Valid <+4.4V = Invalid	6.6.24 4.2.7

TABLE E 3.1.10-128: ATTITUDE INPUT SELECT TYPE 128

CHANNEL 429RX_7	CONNECT TO: AHRS (High Speed)		Fault Designation: AHRS BUS Bus Type: Basic					
			Label	Sig. Bits	Range	Signal Type	Resolution	Rate (ms)
A = J2-23	Data							
B = J2-6	Roll Angle		325	14	±180 degrees	Basic	0.010986328125	10-20
	Pitch Angle		324	14	±180 degrees	Basic	0.010986328125	10-20
	Body Roll Rate		327	13	±128 deg/sec	Basic	0.01562500	10-20
	Body Pitch Rate		326	13	±128 deg/sec	Basic	0.01562500	10-20

Honeywell
MK XXII EGPWS Installation Manual

E 5.3.11 CATEGORY 11, HEADING INPUT SELECT

The following table provides identification of the Heading type. The entry in the Heading Input Select corresponds to a table that provides detailed information on the configuration. For example, the details for Magnetic Heading Input Select #1 are found in 0-1.

In this category, only the following signals are defined:

- Magnetic Heading

TABLE E 3.1.11: HEADING INPUT SELECT FOR EGPWS MK XXII

ID	Heading Input Select (Table E 3.1.11-x)	Description	Effectivity	
			App.	Cfg.
0	0	Analog Magnetic Heading (3-Wire Synchro with reference and validity discrete)	-001	-001
2	2	High Speed ARINC 429 (Note 1)	-006	-006

Note 1: ID 2 is intended to be used in conjunction with Category 10 (Attitude) ID 128.

TABLE E 3.1.11-0: HEADING INPUT SELECT 0

SIGNAL	CONNECTION		SUMMARY DATA		
Magnetic Heading	(X) = J1-22 (Y) = J1-23 (Z) = J1-3 Reference (H) = J1-4 (C) = J1-24		Format: 5 Wire Synchro with Validity Flag Input Type: Basic Fault Designation: MAGNETIC HEADING FAULT Validity: Magnetic Heading Validity Discrete (+28V) Reference: Nominal 26 VAC		
PIN FUNCTION	CONNECTION	PIN TYPE	CHANNEL DESIGNATION REFERENCE	Polarity/Configuration	
Magnetic Heading Validity Discrete	J1-28	Input	28V_DISC_10	>+17V = Valid < +4.4V = Invalid	

TABLE E 3.1.11-2: HEADING INPUT SELECT 2

CHANNEL 429RX_7	CONNECT TO: AHRS (High Speed)		Fault Designation: AHRS BUS Bus Type: Basic					
			Label	Sig. Bits	Range	Signal Type	Resolution	Rate (ms)
A = J2-23 B = J2-6	Data Magnetic Heading		320	15	±180 degrees	Basic	0.0054931640625	10-50

Honeywell
MK XXII EGPWS Installation Manual

E 5.3.12 CATEGORY 12, WINDSHEAR INPUT SELECT

The Windshear warning is not applicable to Helicopters.

The following table provides the definition of Windshear Input Select ID 0, which is used for helicopter installations.

TABLE E 3.1.12: WINDSHEAR INPUT SELECT

ID	Description	Windshear INOP Disable	Windshear Caution Voice Disable	Effectivity	
				App.	Cfg.
0	No Windshear	TRUE	TRUE	-003	-003

Honeywell
MK XXII EGPWS Installation Manual

E 5.3.13 CATEGORY 13, INPUT / OUTPUT DISCRETE TYPE SELECT

The following table provides identification of the Input/Output Discrete Type. Each entry in the Input/Output Discrete Type column has a corresponding table that provides detailed information on the configuration. For example, the details for Input/Output Discrete Type #128 are found in Table E 3.1.13-128.

TABLE E 3.1.13: INPUT/OUTPUT DISCRETE TYPE SELECT FOR EGPWS MK XXII

ID	Input/Output Discrete Type (Table E 3.1.13-x)	Description	Effectivity	
			App.	Cfg.
128	128	Helicopter Input / output discrete definitions (Lamp Format 1)	-003	-003
129	129	Helicopter Input / output discrete definitions (Lamp Format 2)	-003	-003

Honeywell
MK XXII EGPWS Installation Manual

TABLE E 3.1.13-128: INPUT/OUTPUT DISCRETE TYPE 128

CONN PIN #	CHANNEL DESIGNATION REFERENCE	PIN TYPE	PIN FUNCTION	Polarity/Configuration
J1-38	28V_DISC_02	Input	+28V Glideslope Inhibit Discrete	>+17V = Inhibit <+4.4V = Not Inhibit
J1-19	GND_DISC_02	Input	GND Glideslope Inhibit Discrete	Gnd = Inhibit <not> Gnd = Not Inhibit
J1-37	28V_DISC_03	Input	+28V WOW Discrete	>+17V = WOW <+4.4V = Not WOW
J1-18	GND_DISC_03	Input	GND WOW Discrete	Gnd = WOW <not> Gnd = Not WOW
J1-36	28V_DISC_04	Input	+28V Audio Inhibit Discrete	>+17V = Inhibit <+4.4V = Not Inhibit
J1-17	GND_DISC_04	Input	Timed Audio Inhibit Discrete	Gnd = Audio Inhibit Toggle <not> Gnd = Audio Inhibit Not Toggle
J1-35	28V_DISC_05	Input	+28V Landing Gear Discrete	>+17V = Gear Down <+4.4V = Gear Up
J1-16	GND_DISC_05	Input	GND Landing Gear Discrete	Gnd = Gear Down <not> Gnd = Gear Up
J1-15	GND_DISC_06	Input	Glideslope Cancel Discrete (Note 1)	Gnd = Cancel Toggle <not> Gnd = Normal
J1-14	GND_DISC_07	Input	Low Altitude Mode Select (Tactical) (Note 1)	Gnd = Low Altitude Mode Select <not> Gnd = Normal
J1-13	GND_DISC_08	Input	Mode 6 Low Volume Discrete	Gnd = Low Volume <not> Gnd = Normal
J1-8	28V_DISC_09	Input	Autopilot Engaged Discrete #1	>+17V = Engaged <+4.4V = Not Engaged
J1-12	GND_DISC_09	Input	Terrain Awareness Inhibit Discrete (Note 2)	Gnd = Inhibit <not> Gnd = Not Inhibit
J1-34	GND_DISC_10	Input	Self-Test Discrete (Note 1)	Gnd = Self-Test Toggle <not> Gnd = Normal
J1-72	MON_OUT_1	Output	GPWS INOP Discrete	
J1-55	MON_OUT_2	Output	TAD INOP Discrete Terrain Not Available	
J1-78	DISC_OUT_1	Output	GPWS Warning Discrete Terrain Awareness Caution or Warning Obstacle Awareness Caution or Warning	
J1-77	DISC_OUT_2	Output	GPWS Alert Discrete (Glideslope Only)	
J1-76	DISC_OUT_3	Output	Glideslope Cancel Discrete	
J1-73	DISC_OUT_4	Output	Low Altitude Mode Discrete (Tactical)	
J1-69	DISC_OUT_5	Output	TCAS Inhibit discrete	
J1-54	DISC_OUT_6	Output	Terrain Display Select #1 Discrete	
J1-51	DISC_OUT_8	Output	Terrain Awareness Caution or Warning Obstacle Awareness Caution or Warning	Gnd = Terrain Pop Up
J1-49	DISC_OUT_9	Output	Terrain Display Select #2 Discrete	
J1-52	DISC_OUT_7	Output	Timed Audio Inhibit	Gnd = Audio Inhibit
J1-48	28V_DISC_11	Input	Not Defined in this ID (Note 3).	
J1-67	GND_DISC_14	Input	Not Defined in this ID (Note 3).	
J2-15	28V_DISC_13	Input	Not Defined in this ID (Note 3).	
J2-31	GND_DISC_15	Input	Not Defined in this ID (Note 3).	
J1-50	MON_OUT_3	Output	Not Defined in this ID (Note 3).	
Configuration Data			Possible States	State
Lamp Format			Type 1, Type 2	Type 1
Flashing Lamps			True, False	False

Note 1: Provided by Momentary cockpit switch (non-latching)

Note 2: Provided by Alternate cockpit switch (Latching) with guard if inhibiting

Note 3: This discrete may be used in another category.

Honeywell
MK XXII EGPWS Installation Manual

TABLE E 3.1.13-129: INPUT/OUTPUT DISCRETE TYPE 129

CONN PIN #	CHANNEL DESIGNATION REFERENCE	PIN TYPE	PIN FUNCTION	Polarity/Configuration
J1-38	28V_DISC_02	Input	+28V Glideslope Inhibit Discrete	>+17V = Inhibit <+4.4V = Not Inhibit
J1-19	GND_DISC_02	Input	GND Glideslope Inhibit Discrete	Gnd = Inhibit <not> Gnd = Not Inhibit
J1-37	28V_DISC_03	Input	+28V WOW Discrete	>+17V = WOW <+4.4V = Not WOW
J1-18	GND_DISC_03	Input	GND WOW Discrete	Gnd = WOW <not> Gnd = Not WOW
J1-36	28V_DISC_04	Input	+28V Audio Inhibit Discrete	>+17V = Inhibit <+4.4V = Not Inhibit
J1-17	GND_DISC_04	Input	Timed Audio Inhibit Discrete	Gnd = Audio Inhibit Toggle <not> Gnd = Audio Inhibit Not Toggle
J1-35	28V_DISC_05	Input	+28V Landing Gear Discrete	>+17V = Gear Down <+4.4V = Gear Up
J1-16	GND_DISC_05	Input	GND Landing Gear Discrete	Gnd = Gear Down <not> Gnd = Gear Up
J1-15	GND_DISC_06	Input	Glideslope Cancel Discrete (Note 1)	Gnd = Cancel Toggle <not> Gnd = Normal
J1-14	GND_DISC_07	Input	Low Altitude Mode Select (Tactical) (Note 1)	Gnd = Low Altitude Mode Select <not> Gnd = Normal
J1-13	GND_DISC_08	Input	Mode 6 Low Volume Discrete	Gnd = Low Volume <not> Gnd = Normal
J1-8	28V_DISC_09	Input	Autopilot Engaged Discrete #1	>+17V = Engaged <+4.4V = Not Engaged
J1-12	GND_DISC_09	Input	Terrain Awareness Inhibit Discrete (Note 2)	Gnd = Inhibit <not> Gnd = Not Inhibit
J1-34	GND_DISC_10	Input	Self-Test Discrete (Note 1)	Gnd = Self-Test Toggle <not> Gnd = Normal
J1-72	MON_OUT_1	Output	GPWS INOP Discrete	
J1-55	MON_OUT_2	Output	TAD INOP Discrete Terrain Not Available	
J1-78	DISC_OUT_1	Output	GPWS Warning Discrete Terrain Awareness Warning Obstacle Awareness Warning	
J1-77	DISC_OUT_2	Output	GPWS Alert Discrete Terrain Awareness Caution Obstacle Awareness Caution	
J1-76	DISC_OUT_3	Output	Glideslope Cancel Discrete	
J1-73	DISC_OUT_4	Output	Low Altitude Mode Discrete (Tactical)	
J1-69	DISC_OUT_5	Output	TCAS Inhibit discrete	
J1-54	DISC_OUT_6	Output	Terrain Display Select #1 Discrete	
J1-51	DISC_OUT_8	Output	Terrain Awareness Caution or Warning Obstacle Awareness Caution or Warning	Gnd = Terrain Pop Up
J1-49	DISC_OUT_9	Output	Terrain Display Select #2 Discrete	
J1-52	DISC_OUT_7	Output	Timed Audio Inhibit	Gnd = Audio Inhibit
J1-48	28V_DISC_11	Input	Not Defined in this ID (Note 3).	
J1-67	GND_DISC_14	Input	Not Defined in this ID (Note 3).	
J2-15	28V_DISC_13	Input	Not Defined in this ID (Note 3).	
J2-31	GND_DISC_15	Input	Not Defined in this ID (Note 3).	
J1-50	MON_OUT_3	Output	Not Defined in this ID (Note 3).	
Configuration Data			Possible States	State
Lamp Format			Type 1, Type 2	Type 2
Flashing Lamps			True, False	False

Note 1: Provided by Momentary cockpit switch (non-latching)

Note 2: Provided by Alternate cockpit switch (Latching) with guard if inhibiting

Note 3: This discrete may be used in another category.

Honeywell
MK XXII EGPWS Installation Manual

E 5.3.14 CATEGORY 14, AUDIO OUTPUT LEVEL

The following table provides identification of the Audio Output Level Select. Each entry in the ID column corresponds to a particular nominal alert output level selection (Max, -6 dB, -12 dB, -18dB and -24dB). The nominal output is 4 Wrms for the 8-ohm output and 100 mWrms for the 600-ohm output. The Audio Output Level can be additionally reduced by 6dB with the Mode 6 Low Volume discrete (see Category 13). The output power level will be the nominal maximum output (4W or 100mW) reduced by the volume selection from Table 5.3.14 and the Mode 6 Low Volume discrete.

TABLE E 3.1.14: AUDIO OUTPUT LEVEL

ID	Volume Select	Effectivity	
		App	Cfg.
0	Nominal	-001	-001
1	-6 dB	-001	-001
2	-12 dB	-001	-001
3	-18 dB	-001	-001
4	-24 dB	-001	-001

Honeywell
MK XXII EGPWS Installation Manual

E 5.3.15 CATEGORY 15, AUTOROTATION THRESHOLD

The following table provides identification of the Autorotation Threshold. Each entry in the ID column corresponds to an engine torque threshold for autorotation. Each helicopter type has a unique engine torque percentage during autorotation based on the aerodynamic qualities of the aircraft. This value is not typically published or well known, thus it has been included as a configuration item in Table 10.3.15. Since a typical Autorotation Threshold value is between 5% and 10%, the values have been chosen from 0% to 15% in increments of 0.5%.

TABLE E 3.1.15: AUTOROTATION THRESHOLD FOR EGPWS MK XXII

1.1.1.1	Autorotation Threshold	Effectivity	
	% of Torque	App.	Cfg.
0	N/A	EM22 -006	EM22 -006
1	0.5 %	EM22 -006	EM22 -006
2	1.0 %	EM22 -006	EM22 -006
3	1.5 %	EM22 -006	EM22 -006
4	2.0 %	EM22 -006	EM22 -006
5	2.5 %	EM22 -006	EM22 -006
6	3.0 %	EM22 -006	EM22 -006
7	3.5 %	EM22 -006	EM22 -006
8	4.0 %	EM22 -006	EM22 -006
9	4.5 %	EM22 -006	EM22 -006
10	5.0 %	EM22 -006	EM22 -006
11	5.5 %	EM22 -006	EM22 -006
12	6.0 %	EM22 -006	EM22 -006
13	6.5 %	EM22 -006	EM22 -006
14	7.0 %	EM22 -006	EM22 -006
15	7.5 %	EM22 -006	EM22 -006
16	8.0 %	EM22 -006	EM22 -006
17	8.5 %	EM22 -006	EM22 -006
18	9.0 %	EM22 -006	EM22 -006
19	9.5 %	EM22 -006	EM22 -006
20	10.0 %	EM22 -006	EM22 -006
21	10.5 %	EM22 -006	EM22 -006
22	11.0 %	EM22 -006	EM22 -006
23	11.5 %	EM22 -006	EM22 -006
24	12.0 %	EM22 -006	EM22 -006
25	12.5 %	EM22 -006	EM22 -006
26	13.0 %	EM22 -006	EM22 -006
27	13.5 %	EM22 -006	EM22 -006
28	14.0 %	EM22 -006	EM22 -006
29	14.5 %	EM22 -006	EM22 -006
30	15.0 %	EM22 -006	EM22 -006

Honeywell
MK XXII EGPWS Installation Manual

E 6 CONNECTOR INTERFACE

E 6.1 PINOUT FOR FRONT CONNECTORS SORTED BY PIN NUMBER

TABLE E 4: PIN ASSIGNMENT FOR FRONT CONNECTORS SORTED BY PIN NUMBER

Connector - Pin	Channel Designation Reference	Signal Usage Summary*
J1-01	SYN_1X	Roll Attitude Synchro (X leg)
J1-02	SYN_1Z	Roll Attitude Synchro (Z leg)
J1-03	SYN_2Z	Magnetic Heading Synchro (Z leg)
J1-04	26REF_1H	26VAC Reference #1 (H)
J1-05	SYN_3X	Spare Synchro (X leg)
J1-06	SYN_3Z	Spare Synchro (Z leg)
J1-07	SYN_3Y	Spare Synchro (Y leg)
J1-08	28V_DISC_09	Autopilot Engaged Discrete (+28VDC)
J1-09	28V_DISC_08	Barometric Altitude Validity Discrete (+28VDC)
J1-10	GS_VAL_L	Glideslope Deviation Low Level Validity (-)
J1-11	28V_DISC_06	Glideslope Validity Discrete (+28VDC)
J1-12	GND_DISC_09	Terrain Awareness and TCF Inhibit Discrete (Ground)
J1-13	GND_DISC_08	Mode 6 Low Volume Discrete (Ground)
J1-14	GND_DISC_07	Reserved
J1-15	GND_DISC_06	Glideslope Cancel Discrete (Ground)
J1-16	GND_DISC_05	Landing Gear Discrete (Ground)
J1-17	GND_DISC_04	Audio Inhibit Discrete (Ground) or Timed Audio Inhibit Discrete
J1-18	GND_DISC_03	Reserved
J1-19	GND_DISC_02	Glideslope Inhibit Discrete (Ground)
J1-20	GND_DISC_01	ILS Tuned Discrete (Ground)
J1-21	SYN_1Y	Roll Attitude Synchro (Y leg)
J1-22	SYN_2X	Magnetic Heading Synchro (X leg)
J1-23	SYN_2Y	Magnetic Heading Synchro (Y leg)
J1-24	26REF_1L	26VAC Reference #1 (L)
J1-25	OAT_REF	Air Temperature Reference (+5VDC)
J1-26	TORQUE_1H	Engine Torque #1 (+)
J1-27	TORQUE_1L	Engine Torque #1 (-)
J1-28	28V_DISC_10	Magnetic Heading Validity Discrete (+28VDC)
J1-29	28V_DISC_07	Radio Altitude Validity Discrete (+28VDC)
J1-30	GS_VAL_H	Glideslope Deviation Low Level Validity (+)
J1-31	GND_DISC_13	Display Selected Discrete #2 (Ground)
J1-32	GND_DISC_12	Display Selected Discrete #1 (Ground)
J1-33	GND_DISC_11	DH Discrete (Ground)
J1-34	GND_DISC_10	Self Test Discrete (Ground)
J1-35	28V_DISC_05	Landing Gear Discrete (+28VDC)
J1-36	28V_DISC_04	Audio Inhibit Discrete (+28VDC)
J1-37	28V_DISC_03	Reserved
J1-38	28V_DISC_02	Glideslope Inhibit Discrete (+28VDC)
J1-39	28V_DISC_01	ILS 1 Tuned Discrete (+28VDC)
J1-40	PWR_H	Power Input: 28 VDC (+)
J1-41	PWR_L	Power Input: 28 VDC (return)
J1-42	GND	Chassis Ground
J1-43	ALT_L	Barometric Altitude (-)
J1-44	OAT_L	Air Temperature (-)
J1-45	RALT_L	Radio Altitude: ARINC 552 or ALT 55 (-)
J1-46	GSDEV_L	Glideslope Deviation - Low Level (+ down)
J1-47	TORQUE_2L	Engine Torque #2 (-)
J1-48	28V_DISC_11	Spare +28VDC Discrete
J1-49	DISC_OUT_9	Terrain Select Relay Output #2
J1-50	MON_OUT_3	Reserved
J1-51	DISC_OUT_8	Spare Lamp Output

Honeywell
MK XXII EGPWS Installation Manual

Connector - Pin	Channel Designation Reference	Signal Usage Summary*
J1-52	DISC_OUT_7	Spare Output/ Timed Audio Inhibit /Windshear Warning Output**
J1-53	GND	Temperature Probe GND
J1-54	DISC_OUT_6	Terrain Select Relay Output #1
J1-55	MON_OUT_2	TAD / TCF INOP Output (monitor)
J1-56	453TX_2A	Terrain Display Output Data #2 (A leg)
J1-57	453TX_2B	Terrain Display Output Data #2 (B leg)
J1-58	453TX_1A	Terrain Display Output Data #1 (A leg)
J1-59	453TX_1B	Terrain Display Output Data #1 (B leg)
J1-60	PWR_H	Power Input: 28 VDC (+)
J1-61	PWR_L	Power Input: 28 VDC (return)
J1-62	ALT_H	Barometric Altitude (+)
J1-63	OAT_H	Air Temperature (+)
J1-64	RALT_H	Radio Altitude: ARINC 552 or ALT 55 (+)
J1-65	GSDEV_H	Glideslope Deviation - Low Level (+ up)
J1-66	TORQUE_2H	Engine Torque #2 (+)
J1-67	GND_DISC_14	GPWS Inhibit (GND) Discrete or Attitude Validity Discrete
J1-68	28V_DISC_12	Spare +28VDC Discrete
J1-69	DISC_OUT_5	Audio On (GND) Output or TCAS Inhibit Discrete (GND) Output
J1-70	AUD_HL_H	High Level Audio Output - 8Ω (+)
J1-71	AUD_HL_L	High Level Audio Output - 8Ω (-)
J1-72	MON_OUT_1	GPWS INOP Output (monitor)
J1-73	DISC_OUT_4	Reserved
J1-74	AUD_LL_L	Low Level Audio Output – 600Ω (-)
J1-75	AUD_LL_H	Low Level Audio Output - 600Ω (+)
J1-76	DISC_OUT_3	Glideslope Cancel Output
J1-77	DISC_OUT_2	Glideslope Alert Output
J1-78	DISC_OUT_1	GPWS Warning Output
J2-01	SYN_4X	Configurable Synchro #1 (X leg)
J2-02	SYN_4Y	Configurable Synchro #1 (Y leg)
J2-03	SYN_5Z	Configurable Synchro #2 (Z leg)
J2-04	429RX_5B	Radio Altitude ARINC 429 Input (B leg)
J2-05	429RX_6B	ILS ARINC 429 Input (B leg)
J2-06	429RX_7B	Magnetic Heading/Roll ARINC 429 Input (B leg)
J2-07	429RX_8B	Spare ARINC 429 Input (B leg)
J2-08	429RX_4B	GPS ARINC 429 Input (B leg)
J2-09	429TX_2B	EGPWS ARINC 429 Output #2 (B leg)
J2-10	422_232RX_2B	Alt Display Display #2 or ADC RS-232 / 422 Input (B leg)
J2-11	422_232RX_2A	Alt Display Range #2 or ADC RS-232 / 422 Input (A leg)
J2-12	GPS_RXB	GPS RS-232 / 422 Input (B leg)
J2-13		
J2-14	GND	ADC RS-232 Common
J2-15	28V_DISC_13	Spare Discrete Input
J2-16	GND	Configuration Module Power Return (Ground)
J2-17	SC_PWR	Configuration Module Power (+5VDC)
J2-18	SYN_4Z	Configurable Synchro #1 (Z leg)
J2-19	SYN_5X	Configurable Synchro #2 (X leg)
J2-20	SYN_5Y	Configurable Synchro #2 (Y leg)
J2-21	429RX_5A	Radio Altitude ARINC 429 Input (A leg)
J2-22	429RX_6A	ILS ARINC 429 Input (A leg)
J2-23	429RX_7A	Magnetic Heading/Roll ARINC 429 Input (A leg)
J2-24	429RX_8A	Spare ARINC 429 Input (A leg)
J2-25	429RX_4A	GPS ARINC 429 Input (A leg)

Honeywell
MK XXII EGPWS Installation Manual

Connector - Pin	Channel Designation Reference	Signal Usage Summary*
J2-26	429TX_2A	EGPWS ARINC 429 Output #2 (A leg)
J2-27	422_232TX_2A	ADC RS-232 / 422 Output (A leg)
J2-28	GND	GPS / ADC RS-232 / 422 Common
J2-29	GPS_RXA	GPS RS-232 / 422 Input (A leg)
J2-30		
J2-31	GND_DISC_15	Spare Discrete Input
J2-32	SPICLK	Configuration Module Serial Clock
J2-33	SPIMISO	Configuration Module Serial Input
J2-34	26REF_2H	26VAC Reference #2 (H)
J2-35	26REF_2L	26VAC Reference #2 (L)
J2-36	429_422RX_1	Display Range #1 ARINC 429 (B leg) RS-422 Input (A leg)
J2-37	429_422RX_1	Display Range #1 ARINC 429 (A leg) RS-422 Input (B leg)
J2-38	429RX_2B	Air Data ARINC 429 Input (B leg)
J2-39	429RX_2A	Air Data ARINC 429 Input (A leg)
J2-40	429RX_3B	Display Range #2 ARINC 429 Input (B leg)
J2-41	429RX_3A	Display Range #2 ARINC 429 Input (A leg)
J2-42	429TX_1B	EGPWS ARINC 429 Output #1 (B leg)
J2-43	429TX_1A	EGPWS ARINC 429 Output #1 (A leg)
J2-44	422_232TX_2B	ADC RS-232 / 422 Output (B leg)
J2-45	GPS_TXA	GPS RS-232 / 422 Output (A leg)
J2-46	GPS_TXB	GPS RS-232 / 422 Output (B leg)
J2-47		
J2-48		
J2-49	SPISEL_CM#	Configuration Module Serial Select
J2-50	SPIMOSI	Configuration Module Serial Output
J3-01	GND	SmartCable Power Return (Ground)
J3-02	CARD_PRES#	PCMCIA Card Present
J3-03	RS232RXD_MON	EGPWS Monitor Port (RS232 Receive)
J3-04	RS232TXD_MON	EGPWS Monitor Port (RS232 Transmit)
J3-05		Reserved
J3-06	SC_PWR	SmartCable Power (+5VDC)
J3-07	SPICLK	SmartCable Serial Clock
J3-08	SPIMISO	SmartCable Serial Input
J3-09	SPIMOSI	SmartCable Serial Output
J3-10	SPISEL_SC#	SmartCable Serial Select
J3-11	GSE_PRES#	GSE Present
J3-12	GND	Ground
J3-13	GND	Ground
J3-14	GND	Ground
J3-15		Reserved
GPS ANT	COAX	GPS COAX connection

*Refer to Category 13 where multiple uses are possible.

**Honeywell
MK XXII EGPWS Installation Manual**

Figure E 4, Front Panel Connector Orientation - J1, J2, J3, GPS ANT

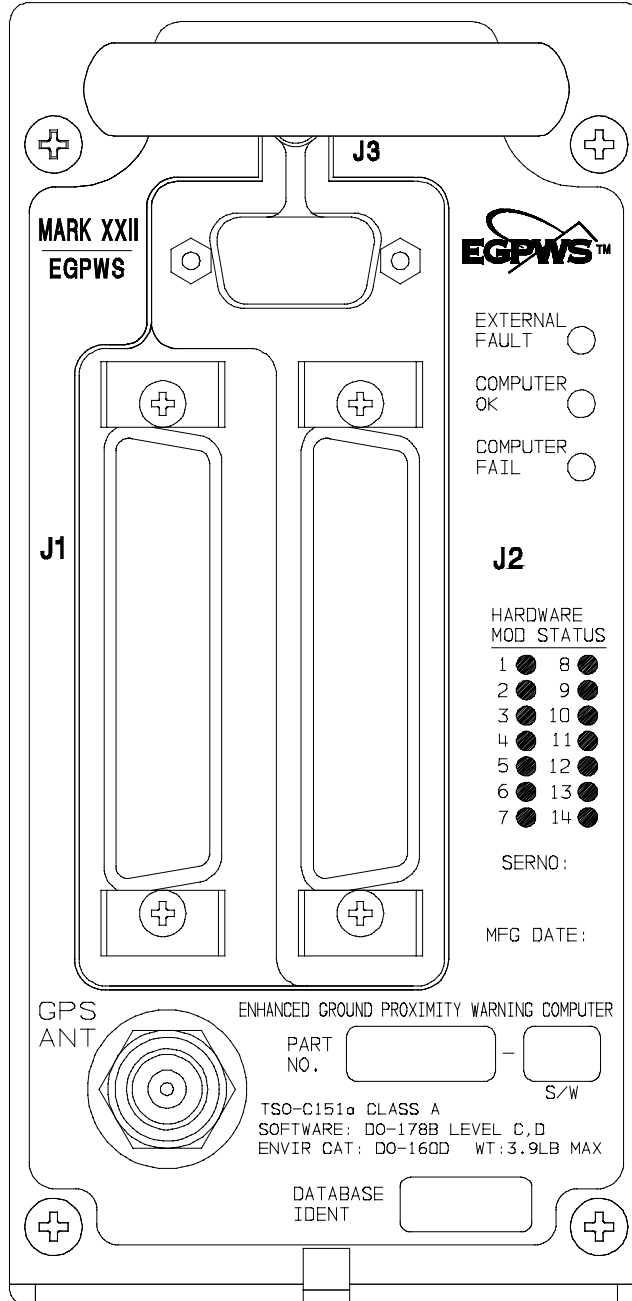

Honeywell
MK XXII EGPWS Installation Manual

Figure E 4.1, Connector Pin References - J1, J2, J3

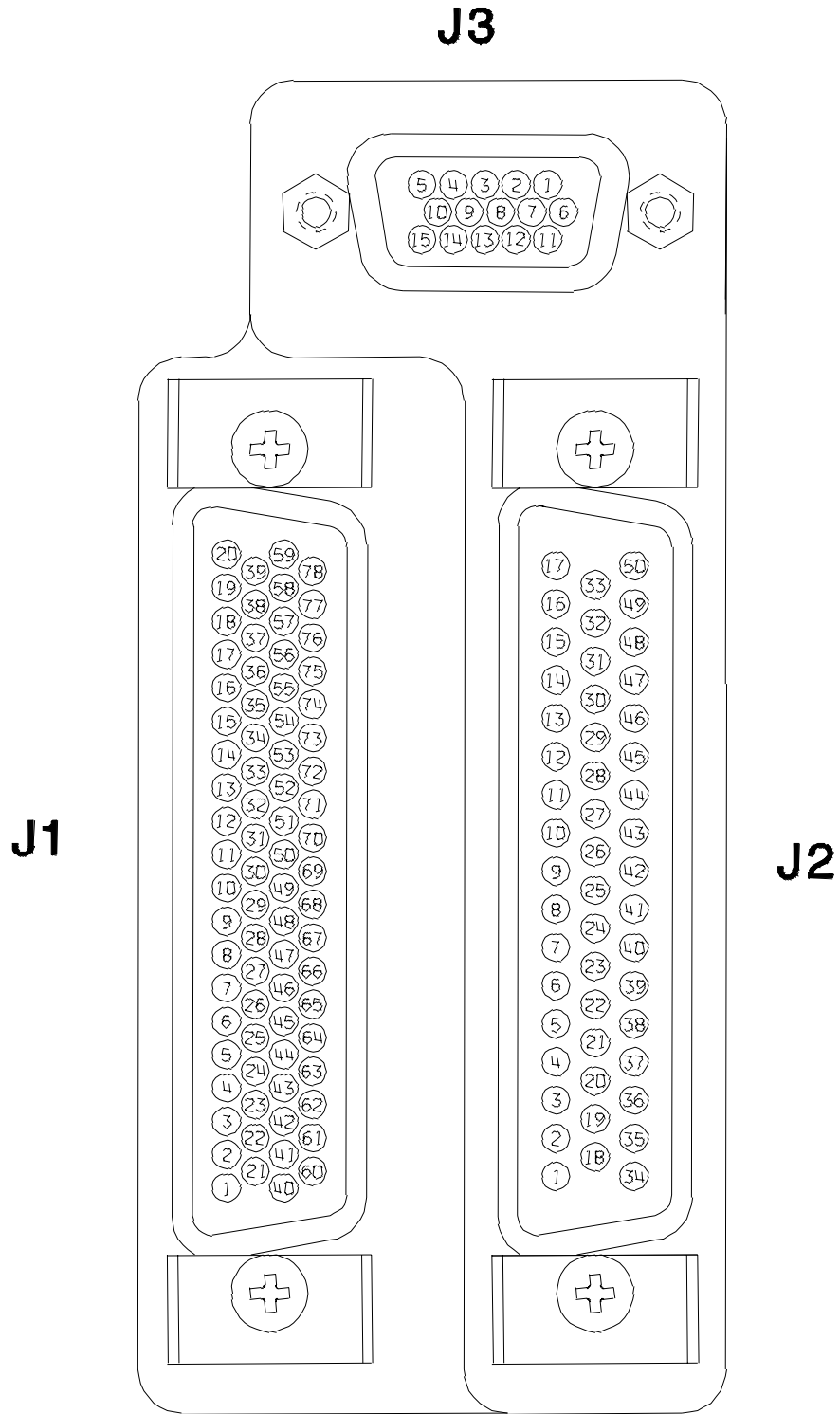

Honeywell
MK XXII EGPWS Installation Manual

E 7 DEFINITIONS

The following acronyms are provided for use with this document:

<u>Acronym</u>	<u>Interpretation</u>
AAAS	Alternate Audio Alert Select
ADC	Air Data Computer
ADS	Air Data System
AGL	Above Ground Level
AHRS	Attitude Heading Reference System
AIC	Analog Input Controller
AIMS	Airplane Information Management System
AOA	Angle of Attack
ASA	AlliedSignal Aerospace
ASL	Above Sea Level
ATP	Acceptance Test Procedure
BCD	Binary Coded Decimal
BIST	Built in Self Test
BIT	Built In Test
BITE	Built In Test Equipment
BNR	Binary
BOSS	Batch Oriented Simulation System
C/O	Callouts
CAA	Civil Aviation Authority
CAIMS	Central Aircraft Information/Maintenance System
CFDS	Centralized Fault Display System
CFIT	Controlled Flight Into Terrain
CFM	Cubic Feet per Minute
CISRD	CFDS Interface System Requirements Document
CMC	Central Maintenance Computer
COTS	Commercial Off the Shelf
CP	Control Panel
CRS	Course
CW	Clockwise
DAA	Digital/Analog Adapter
DADC	Digital Air Data Computer
DAU	Data Acquisition Unit
DC	Digital Command
DDM	Difference in Depth of Modulation
DEVN	Deviation
DH	Decision Height
DITS	Digital Information Transfer System
DME	Distance Measuring Equipment
DO	Discrete Output
DSP	Digital Signal Processor
DSU	Display Switching Unit
DSWC	Digital Stall Warning Computer
EEPROM	Electrically Erasable Programmable Read Only Memory
EFCP	EFIS Control Panel
EFIS	Electronic Flight Instrument System
EGPWC	Enhanced Ground Proximity Warning Computer
EGPWD	Enhanced Ground Proximity Warning Display
EGPWS	Enhanced Ground Proximity Warning System
EICAS	Engine Indication and Crew Alert System
EMI	Electromagnetic Interference
ENB	Enabled
EPROM	Erasable Programmable Read Only Memory

Honeywell
MK XXII EGPWS Installation Manual

<u>Acronym</u>	<u>Interpretation</u>
F/T	Functional Test
F/W	Fail/Warning
F/W	Fail/Warning
FAA	Federal Aviation Administration
FCC	Flight Control Computer
FDR	Flight Data Recorder
FIAS	Flight Inspection Aircraft System
FMC	Flight Management Computer
FMS	Flight Management System
FPM	Feet per Minute
FSEU	Flaps/Slats Electronic Unit
FWC	Fault Warning Computer
G/S	Glideslope
GMT	Greenwich Mean Time
GPS	Global Position System
GPW	Ground Proximity Warning
GPWS	Ground Proximity Warning System
GT	Greater Than
H/W	Hardware
HDG	Heading
HDOP	Horizontal Dilution of Position
HSID	Hardware/Software Interface Document
I/O	Input/Output
IAC	Integrated Avionics Computer
ICD	Interface Control Document
ILS	Instrument Landing System
INOP	Inoperative
IOC	Input/Output Concentrator
IRS	Inertial Reference System
ISO	International Standards Organization
IVS	Inertial Vertical Speed
KT	Knots
KTS	Knots
LED	Light Emitting Diode
LRRRA	Low Range Radio Altimeter
LRU	Line Replaceable Unit
LSB	Least Significant Bit
LT	Less Than
MCP	Mode Control Panel
MDA	Minimum Barometric Altitude
MFD	Multi-Functional Display
MKII	Mark Two Warning Computer
MKV	Mark Five Warning Computer
MKVI	Mark Six Warning Computer
MKVII	Mark Seven Warning Computer
MKVIII	Mark Eight Warning Computer
MKXXII	Mark Twenty Two Warning Computer
MLS	Microwave Landing System
MMU	Memory Management Unit
MSB	Most Significant Bit
N/A	Not Applicable
NCD	No Computed Data
ND	Navigation Display
NVM	Non Volatile Memory
OMS	Onboard Maintenance System
P/N	Part Number
PAR	Parity

Honeywell
MK XXII EGPWS Installation Manual

<u>Acronym</u>	<u>Interpretation</u>
PC	Personal Computer
PCMCIA	Personal Computer Memory Card Industry Association
PFD	Primary Flight Display
PMAT	Portable Maintenance Access Terminal
PP	Program Pin
PVM	Processor/Voice/Memory
PWS	Predictive Windshear System
QFE	Corrected Baro Alt relative to field elevation
QNH	Corrected Baro Alt relative to sea level
RA	Radio Altitude
RAM	Random Access Memory
RDOP	Radar Display Output Processing
ROM	Read Only Memory
RTCA	Requirements and Technical Concepts for Aviation
RTS	Ready to Transmit Signal
RWY	Runway
S/T	Self Test
S/W	Software
SDI	Source/Destination Identifier
SDRD	Software Design Requirements Document
SIG	Significant
SPC	Stall Protection Computer
SRD	System Requirements Document
SSM	Sign Status Matrix
ST	Self Test
SWC	Stall Warning Computer
TA&D	Terrain Awareness & Display
TACAN	Tactical Air Navigation
TAD	Terrain Awareness Display
TBD	To Be Determined
TCAS	Traffic Collision Avoidance System
TCF	Terrain Clearance Floor
TERPS	United States' Standards for Terminal Instrument Procedures
TK	Track
TLB	Translation Lookaside Buffer
TSO	Technical Standing Order
TTL	Tuned To Localizer
UART	Universal Asynchronous Receiver Transmitter
USM	Unsigned Magnitude
UTC	Universal Time Correlation
UUT	Unit Under Test
VDC	Volts, DC
VDOP	Vertical Dilution of Precision
VHF	Very High Frequency
VLSI	Very Large Scale Integrated Circuit
VOR	VHF Omni-directional Range
W/S	Windshear
WC	Warning Computer
WX	Weather