

VF-S11 *DeviceNet* Built-in Board Option

DEV001Z

Function Manual

* The data given in this manual are subject to change without notice.

Toshiba Inverter Corporation

© TOSHIBA INVERTER CORPORATION 2004
All rights reserved.

Contents

1. INTRODUCTION	3
1.1. Usage Precautions	3
1.2. General Specifications	3
2. CONNECTION INFORMATION.....	4
2.1. Connection Sizes.....	4
2.2. Names and functions	4
2.3. DeviceNet indicators (Status LED).....	5
2.4. VF-S11 communication parameters.....	6
3. OBJECT SPECIFICATIONS	7
3.1. Identity Object.....	8
3.1.1. Identity Object Class Attributes	8
3.1.2. Identity Object Instance Attributes.....	8
3.1.3. Identity Object Common Services.....	8
3.1.4. Identity Object Specific Services	8
3.2. Message Router	9
3.2.1. Message Router Class Attributes.....	9
3.2.2. Message Router Instance Attributes	9
3.2.3. Message Router Common Services	9
3.2.4. Message Router Specific Services	9
3.3. DeviceNet Object	10
3.3.1. DeviceNet Object Class Attributes	10
3.3.2. DeviceNet Object Instance Attributes	10
3.3.3. DeviceNet Object Common Services.....	10
3.3.4. DeviceNet Object Specific Services.....	10
3.4. Assembly Object	11
3.4.1. Assembly Object Class Attributes	11
3.4.2. Assembly Object Instance Attributes	11
3.4.3. Assembly Object Common Services.....	11
3.4.4. Assembly Object Specific Services	11
3.4.5. Assembly Instance Details	12
3.4.5.1. Instance 20/70 – DeviceNet Standard ($F B 9 4 = 0$)	12
3.4.5.2. Instance 21/71 – DeviceNet Standard ($F B 9 4 = 1$)	13
3.4.5.3. Instance 100/150 – Toshiba Specific ($F B 9 4 = 2$).....	15
3.4.5.4. Instance 101/151 – Toshiba Specific ($F B 9 4 = 3$).....	17
3.5. Connection Object.....	19
3.5.1. Connection Object Attributes	19
3.5.2. Connection Object Instance Attributes.....	19
3.5.2.1. Explicit Messaging Connection Object Instance Attributes (Instance 1).....	19
3.5.2.2. Poll Connection Object Instance Attributes (Instance 2)	20
3.5.3. Connection Class Common Services.....	20
3.5.4. Connection Class Specific Services.....	20
3.6. Motor Data Object	21
3.6.1. Motor Data Object Class Attributes	21
3.6.2. Motor Data Object Instance Attributes	21
3.6.3. Motor Data Object Common Services	21
3.6.4. Motor Data Object Specific Services.....	21
3.7. Control Supervisor Object	22
3.7.1. Control Supervisor Object Class Attributes	22
3.7.2. Control Supervisor Object Instance Attributes	22
3.7.3. Control Supervisor Object Common Services	23
3.7.4. Control Supervisor Object Specific Services.....	23

3.8.	AC Drive Object.....	24
3.8.1.	AC Drive Object Class Attributes	24
3.8.2.	AC Drive Object Instance Attributes.....	24
3.8.3.	AC Drive Object Common Services	24
3.8.4.	AC Drive Object Specific Services	24
3.9.	Vender Specific Device Pro-files	25
3.10.	About EDS-file	25

1. Introduction

Thank you for purchasing the DeviceNet communications interface PWB “DEV001Z” for the VFS11. Before using the DeviceNet interface, please familiarize yourself with the product and be sure to thoroughly read the instructions and precautions contained in this manual.

In addition, please make sure that this manual and “Instruction Manual” is delivered to the end user, and keep this instruction manual in a safe place for future reference or drive/interface inspection.

This manual describes the supported functions for the “DEV001Z”.

In conjunction with this manual, the following manuals are supplied by Toshiba, and are essential both for ensuring a safe, reliable system installation as well as for realizing the full potential of the “DEV001Z”:

- TOSVERT VF-S11 Instruction Manual
- DEV001Z Instruction Manual (Installation, Wiring, etc.)

1.1. Usage Precautions

- Do not touch charged parts of the drive such as the terminal block while the drive’s CHARGE lamp is lit. A charge will still be present in the drive’s internal electrolytic capacitors, and therefore touching these areas may result in an electrical shock. Always turn all drive input power supplies OFF, and wait at least 5 minutes after the CHARGE lamp has gone out before connecting communication cables or motor wiring.
- Proper ground connections are vital for both safety and signal reliability reasons. For proper grounding procedures, please refer to the ASD instruction manual for drive considerations and the *ODVA DeviceNet Specifications* for network considerations.
- Route all communication cables separate from drive input/output power wiring.
 - To avoid the possibility of electric shock due to leakage currents, always ground the drive’s E/GND terminal and the motor. To avoid misoperation, do not connect the DeviceNet network SHIELD terminal directly to either of the above-mentioned grounds or any other power ground.
- Do not assign the same MAC ID to more than one DeviceNet unit in the same network. For an explanation of station addressing, refer to Instruction Manual.

1.2. General Specifications

LED Indicators

One bicolor red/green Module Status LED and Network Status LED.

Behavior according to ODVA DeviceNet Specifications

When a Watchdog is generated, each LED carries out the same display operation as reset.

Compatibility

Group 2 Server Only device utilizing the Predefined Master / Slave Connection Set.

DeviceNet AC Drive Profile

Vendor-specific I/O POLL connection (8 bytes of data consumed and 8 bytes of data produced). This product has been self-tested by Toshiba Inverter Corporation and found to comply with ODVA Conformance Test Software Version A-17.

2. Connection Information

2.1. Connection Sizes

Connection Instance	Produced	Consumed
I/O Messaging	4 or 8 bytes	4 or 8 bytes
Explicit Messaging	49 bytes	49 bytes

Notes

- For the Explicit Messaging connection, this is the maximum message length: shorter messages are also acceptable.
- For the Polled I/O connection, if the actual consumed data size is less than the connection instance's consumed_connection_size attribute, the consumed data will be ignored, but the connection will otherwise produce normally. If the actual consumed data size is larger than the connection instance's consumed_connection_size attribute, the consumed data will be ignored and the connection will not produce.

2.2. Names and functions

The external view of this option and the name of each part are shown below:

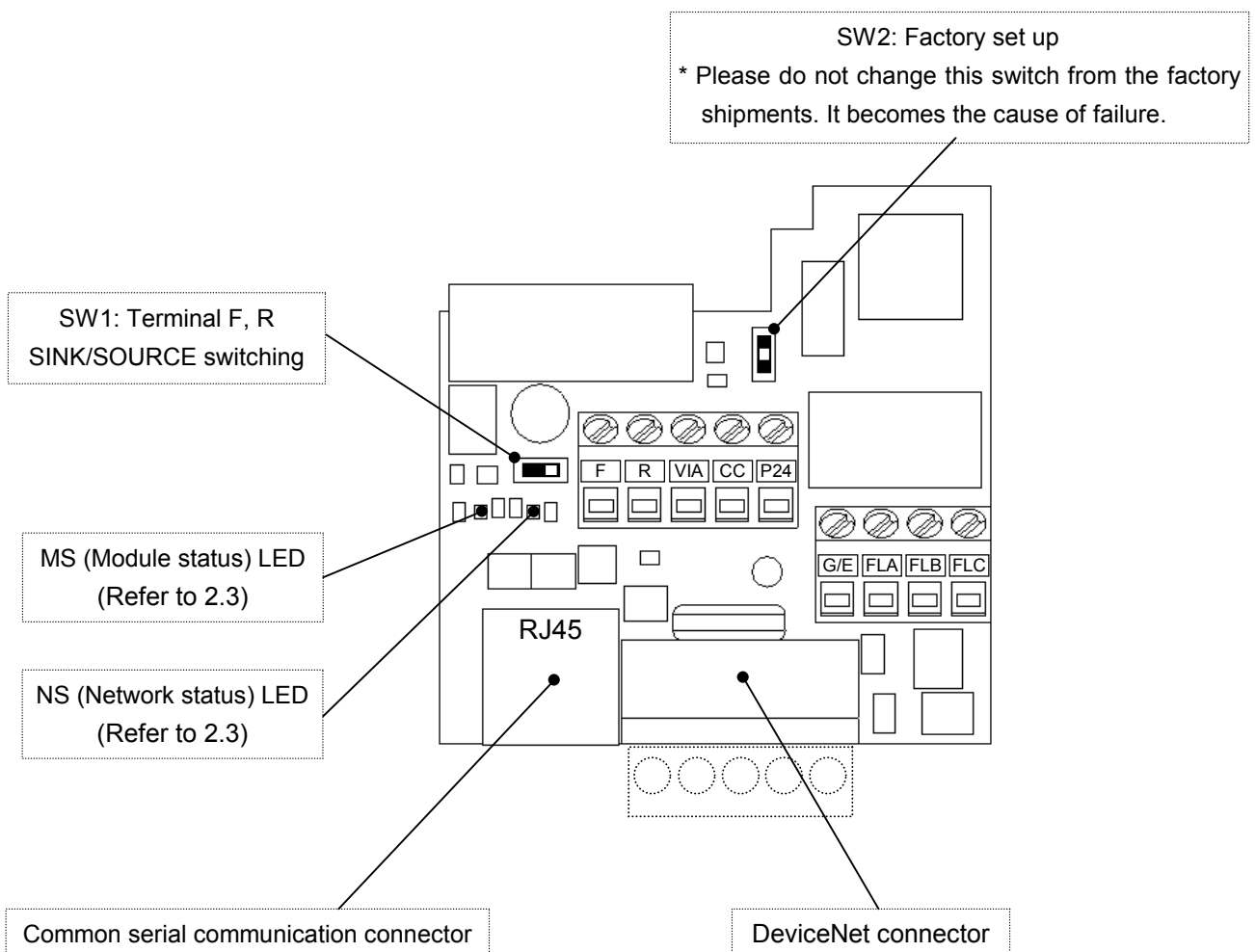

2.3. DeviceNet indicators (Status LED)

MS (Module status)

This bi-color (green/red) LED indicates the status of the communication link from DEV001Z to the VF-S11. It indicates whether or not the device has power and is operating properly. (According to ODVA DeviceNet Specifications.)

LED is:	For this state:	To indicate:
Off	Power OFF	There is no power applied to the device.
Green	Device Operational	The device is operating in a normal condition.
Flashing Green	Device in Standby	The device needs commissioning due to configuration missing, incomplete or incorrect. * When a setup of the parameter <i>F890 - F894</i> is outside the range, it will be in this state. The Device may be in the Standby state.
Flashing Red	Minor Fault	Recoverable Fault
Red	Unrecoverable Fault	The device has an unrecoverable fault; may need replacing.
Flashing Red-Green	Device Self Testing	The Device is in Self Test.

NS (Network status)

This bi-color (green/red) LED indicates the status of the communication link from the DEV001Z to DeviceNet. (According to ODVA DeviceNet Specifications.)

LED is:	For this state:	To indicate:
Off	Not Powered/Not On-line	Device is not on-line. - The device has not completed the Dup_MAC_ID test yet. - The device may not be powered, look at Module Status LED.
Green	On-line and connect	The device is on-line and has connections in the established state. - The device is allocated to a Master.
Flashing Green	On-line, not connect	Device is connected to the network but has no connections in the established state. - The device is not allocated to a master.
Flashing Red	Connection Time-out	Recoverable Fault. One or more I/O Connections are in the Timed-Out state.
Red	Critical Link Failure	Non Recoverable fault. The device has detected an error that has rendered it incapable of communicating on the network (Duplicate MAC ID, or Bus-off). Check parameters <i>F890, F891</i> then Cycle power to VF-S11 to reset this fault.

2.4. VF-S11 communication parameters

In a network, VF-S11 (DEV001Z) serves as a DeviceNet slave device. The DEV001Z configuration is set by the following parameters.

The supported parameters for each drive and their allowable adjustment ranges are defined in the appropriate Electronic Data Sheet (EDS) files. EDS files can be downloaded via the internet from

<http://www.inverter.co.jp/product/inv/vfs11/dev/>

Parameter	Function	Adjustment range	Shipment
<i>F800</i>	RJ45 Communication speed	0: 1200bps 1: 2400bps 2: 4800bps 3: 9600bps 4: 19200bps	3
<i>F803</i>	Communication error trip time	0: Disabled 1- 100 (s)	0
<i>F890</i>	MAC ID	0 - 63	0
<i>F891</i>	DeviceNet Communication speed	0: 125kbps 1: 250kbps 2: 500kbps	0
<i>F892</i>	Communications Loss action (Network wire breaks)	0: Stop, Communication release 1: No action 2: Deceleration stop 3: Coast stop 4: Emergency stop 5: Preset speed command (Preset speed by <i>F893</i> setting)	0
<i>F893</i>	Preset speed No.	0: No action 1-15: Preset speed	0
<i>F894</i>	Assembly Object	0: Instance 20/70 1: Instance 21/71 2: Instance 100/150 3: Instance 101/151	0

*1 Parameter *F800* is VF-S11 internal communication speed. It is recommended that the "4" is set to *F800* for getting faster response.

*2 For safty, set the communication error trip time (*F803*).

*3 When out of range values are set up, the MS (Module Status) LED and will flash green continuously to indicate an invalid set-up. DeviceNet communication is not possible in this state.

*4 When the parameters are changed, the power must be cycled to the VF-S11 for the changes to take effect.

3. Object Specifications

This section contains the object specifications for all DeviceNet objects currently supported by the "DEV001Z". Table 1 outlines those objects covered:

Class Code	Object Class	Page
0x01	Identity	8
0x02	Message Router	9
0x03	DeviceNet	10
0x04	Assembly	11
0x05	Connection	19
0x28	Motor Data	21
0x29	Control Supervisor	22
0x2A	AC/DC Drive	24

TABLE 1: SUPPORTED OBJECTS

For definitions of all data types referred to in these object specifications, refer to the ODVA DeviceNet Specifications. In general, however, the following are some of the most prevalent types:

SINT.....Signed 8-bit integer value
 USINT.....Unsigned 8-bit integer value
 BYTE.....Bit string – 8-bits
 INT.....Signed 16-bit integer value
 UINT.....Unsigned 16-bit integer value
 WORD.....Bit string – 16-bits
 UDINT.....Unsigned 32-bit integer value

3.1. Identity Object

Class code 0x01. This object provides identification of and general information about the device.

3.1.1. Identity Object Class Attributes

Attribute ID	Name	Data Type	Access Rules	Description	Default Value
1	Revision	UINT	Get	Revision of this object	1
2	Max instance	UINT	Get	Maximum instance number of an object currently created in this class level of the device	1

3.1.2. Identity Object Instance Attributes

Attribute ID	Name	Data Type	Access Rules	Description	Default Value
1	Vendor ID	UINT	Get	Identification of vendor by number	377
2	Device type	UINT	Get	Indication of general type of product	2 (AC Drive)
3	Product code	UINT	Get	Identification of a particular product of an individual vendor	1
4	Revision (Major)	USINT (ARRAY)	Get	Revision of the item the Identity Object represents	(104)*
	Revision (Minor)	USINT (ARRAY)	Get		(1)**
5	Status (bits supported)	WORD	Get	Summary status of device	-
6	Serial number	UDINT	Get	Serial number of device	-
7	Product name	SHORT_STRING	Get	Human-readable identification	"DEV001Z DeviceNet TB Option"
8	State	USINT	Get	Present state of the device 0 = Non-existent 1 = Device Self Testing 2 = Standby 3 = Operational 4 = Major Recoverable Fault 5 = Major Unrecoverable Fault	-

3.1.3. Identity Object Common Services

Service Code	Service Name	Supported		Description of Service
		Class	Instance	
0x05	Reset	N/A	Yes	Invokes the Reset service for the device
0x0E	Get_Attribute_Single	Yes	Yes	Returns the contents of the specified attribute.

3.1.4. Identity Object Specific Services

The Identity Object provides no object specific services.

Notes

* Revision is the same value as the VF-S11 CPU version.

** Minor revision is the revision of the DEV001Z software.

3.2. Message Router

Class code 0x02. The Message Router Object provides a messaging connection point through which a Client may address a service to any object class or instance residing in the DeviceNet interface unit.

3.2.1. Message Router Class Attributes

Not supported.

3.2.2. Message Router Instance Attributes

Attribute ID	Name	Data Type	Access Rules	Description	Default Value
1	Object List	USINT (ARRAY)	Get	A list of supported objects	-

3.2.3. Message Router Common Services

Service Code	Service Name	Supported		Description of Service
		Class	Instance	
0x0E	Get_Attribute_Single	N/A	Yes	Returns the contents of the specified attribute.

3.2.4. Message Router Specific Services

The Message Router provides no object specific services.

3.3. DeviceNet Object

Class Code 0x03. The DeviceNet Object provides for the configuration and status of a DeviceNet port.

3.3.1. DeviceNet Object Class Attributes

Attribute ID	Name	Data Type	Access Rules	Description	Default Value
1	Revision	UINT	Get	Revision of this object.	2

3.3.2. DeviceNet Object Instance Attributes

Attribute ID	Name	Data Type	Access Rules	Description	Default Value
1	MAC ID	USINT	Get/Set	Node address	-*
2	Baud rate	USINT	Get/Set	Baud rate 0 = 125kbps 1 = 250kbps 2 = 500kbps	-*
4	Bus-off counter	USINT	Get/Set	Number of times CAN went to the bus-off state	0
5	Allocation information (Allocation Choice Byte)	BYTE (ARRAY)	Get		-
	Allocation information (Master's MAC ID)	USINT (ARRAY)	Get	MAC ID of Master (from Allocate)	-

3.3.3. DeviceNet Object Common Services

Service Code	Service Name	Supported		Description of Service
		Class	Instance	
0x0E	Get_Attribute_Single	Yes	Yes	Returns the contents of the specified attribute.
0x10	Set_Attribute_Single	N/A	Yes	Modifies the value of the specified attribute.

3.3.4. DeviceNet Object Specific Services

Service Code	Service Name	Supported		Description of Service
		Class	Instance	
0x4B	Allocate_Master/Slave_Connection_Set	N/A	Yes	Requests the use of the Predefined Master/Slave Connection Set.
0x4C	Release_Group_2_Identifier_Set	N/A	Yes	Indicates that the specified connections within the Predefined Master/Slave Connection Set are no longer desired. These connections are to be released (deleted).

Notes

* The MAC ID and Baud Rate are settable by parameter *F890* and *F891*.

3.4. Assembly Object

Class code 0x04. The Assembly Object binds attributes of multiple objects, which allows data to or from each object to be sent or received over a single connection.

3.4.1. Assembly Object Class Attributes

No supported.

3.4.2. Assembly Object Instance Attributes

Attribute ID	Name	Data Type	Access Rules	Description	Default Value
3	Data	BYTE (ARRAY)	Get/Set	The data contained in the assembly object.	-

3.4.3. Assembly Object Common Services

Service Code	Service Name	Supported		Description of Service
		Class	Instance	
0x0E	Get_Attribute_Single	N/A	Yes	Returns the contents of the specified attribute.
0x10	Set_Attribute_Single	N/A	Yes	Modifies the value of the specified attribute.

3.4.4. Assembly Object Specific Services

The Assembly Object for static assemblies provides no object specific services.

3.4.5. Assembly Instance Details

3.4.5.1. Instance 20/70 – DeviceNet Standard ($F894 = 0$)

Byte	Bit 7	Bit 6	Bit 5	Bit 4	Bit 3	Bit 2	Bit 1	Bit 0
0	-	-	-	-	-	Fault reset	-	Run forward
1	-							
2	Drive Reference Speed min^{-1} (Low byte) *							
3	Drive Reference Speed min^{-1} (High byte) *							

Fig. 1 Output Instance 20 Layout

Byte	Bit 7	Bit 6	Bit 5	Bit 4	Bit 3	Bit 2	Bit 1	Bit 0
0	-	-	-	-	-	Running Forward	-	Faulted/tripped
1	-							
2	Drive Actual Speed min^{-1} (Low byte)							
3	Drive Actual Speed min^{-1} (High byte)							

Fig. 2 Input Instance 70 Layout

Examples of Instance 20/70

Stop

Instance	Byte	15	14	13	12	11	10	9	8	7	6	5	4	3	2	1	0	Hex.
Output Instance 20	1, 0	0	0	0	0	0	0	0	0	0	0	0	0	0	0	0	0	0x0000
	3, 2	-	-	-	-	-	-	-	-	-	-	-	-	-	-	-	-	-
Input Instance 70	1, 0	0	0	0	0	0	0	0	0	0	0	0	0	0	0	0	0	0x0000
	3, 2	0	0	0	0	0	0	0	0	0	0	0	0	0	0	0	0	0x0000

Forward running 1800 min^{-1}

Instance	Byte	15	14	13	12	11	10	9	8	7	6	5	4	3	2	1	0	Hex.
Output Instance 20	1, 0	0	0	0	0	0	0	0	0	0	0	0	0	0	0	0	1	0x0001
	3, 2	0	0	0	0	0	1	1	1	0	0	0	0	1	0	0	0	0x0708
Input Instance 70	1, 0	0	0	0	0	0	0	0	0	0	0	0	0	0	1	0	0	0x0004
	3, 2	0	0	0	0	0	1	1	1	0	0	0	0	1	0	0	0	0x0708

Fault reset **

Instance	Byte	15	14	13	12	11	10	9	8	7	6	5	4	3	2	1	0	Hex.
Output Instance 20	1, 0	0	0	0	0	0	0	0	0	0	0	0	0	0	1	0	0	0x0004
	3, 2	-	-	-	-	-	-	-	-	-	-	-	-	-	-	-	-	-

* Drive Reference Speed is set up number of rotations by the hexadecimal number.

For example, when "Frequency reference" is set up to 1800 min^{-1} :

1800 = 0x0708 (Hex.)

** Fault reset works only 1 time when 0 -> 1.

3.4.5.2. Instance 21/71 – DeviceNet Standard ($F894 = 1$)

Byte	Bit 7	Bit 6	Bit 5	Bit 4	Bit 3	Bit 2	Bit 1	Bit 0
0	-	Net Ref *	Net Ctrl *	-	-	Fault reset	Run reverse	Run forward
1	-							
2	Drive Reference Speed min^{-1} (Low byte)							
3	Drive Reference Speed min^{-1} (High byte)							

Fig. 3 Output Instance 21 Layout

Byte	Bit 7	Bit 6	Bit 5	Bit 4	Bit 3	Bit 2	Bit 1	Bit 0
0	At reference **	Ref from Net **	Ctrl from Net **	Ready	Running Reverse	Running Forward	Warning	Faulted/tripped
1	Drive Status ***							
2	Drive Actual Speed min^{-1} (Low byte)							
3	Drive Actual Speed min^{-1} (High byte)							

Fig. 4 Input Instance 71 Layout

* Bit 5 and 6 of the instance 21 byte 0 are defined as follows.

Bit 5 (Net Ctrl)..... When “1” is set, bits 0 (Run forward) and 1 (Run reverse) of byte 0 are enabled.
When “0” is set, Run/Stop is according to setup of the parameter CND .

Bit 6 (Net Ref)..... When “1” is set, bytes 2 and 3 are enabled.

When “0” is set, Drive Reference Speed is according to setup of the parameter FND .

** Bit 5, 6, and 7 of the instance 71 byte 0 are defined as follows.

Bit 5 (Ctrl from Net)..... When RUN/STOP command from DeviceNet is enabled, “1” is set.

Bit 6 (Ref from Net)..... When frequency command from DeviceNet is enabled, “1” is set.

Bit 7 (At reference)..... When output frequency becomes the same as frequency command, “1” is set.

*** Drive Status is same as the Control Supervisor class State attribute (refer to section 3.7.2).

1 (= BN: 00000001): Startup

2 (= BN: 00000010): Not Ready

3 (= BN: 00000011): Ready

4 (= BN: 00000100): Enabled

5 (= BN: 00000101): Stopping

6 (= BN: 00000110): Fault Stop

7 (= BN: 00000111): Faulted

Examples of Instance 21/71

Stop

Instance	Byte	15	14	13	12	11	10	9	8	7	6	5	4	3	2	1	0	Hex.
Output Instance 21	1, 0	0	0	0	0	0	0	0	0	0	0	0	0	0	0	0	0	0x0000
	3, 2	-	-	-	-	-	-	-	-	-	-	-	-	-	-	-	-	-
Input Instance 71	1, 0	0	0	0	0	0	0	1	1	0	0	0	1	0	0	0	0	0x0310
	3, 2	0	0	0	0	0	0	0	0	0	0	0	0	0	0	0	0	0x0000

Forward running 1800min-1

Instance	Byte	15	14	13	12	11	10	9	8	7	6	5	4	3	2	1	0	Hex.
Output Instance 21	1, 0	0	0	0	0	0	0	0	0	0	1	1	0	0	0	0	1	0x0061
	3, 2	0	0	0	0	0	1	1	1	0	0	0	0	1	0	0	0	0x0708
Input Instance 71	1, 0	0	0	0	0	0	1	0	0	1	1	1	1	0	1	1	0	0x04F6
	3, 2	0	0	0	0	0	1	1	1	0	0	0	0	1	0	0	0	0x0708

Reverse running 1800min-1

Instance	Byte	15	14	13	12	11	10	9	8	7	6	5	4	3	2	1	0	Hex.
Output Instance 21	1, 0	0	0	0	0	0	0	0	0	0	1	1	0	0	0	1	0	0x0062
	3, 2	0	0	0	0	0	1	1	1	0	0	0	0	1	0	0	0	0x0708
Input Instance 71	1, 0	0	0	0	0	0	1	0	0	1	1	1	1	1	0	1	0	0x04FA
	3, 2	0	0	0	0	0	1	1	1	0	0	0	0	1	0	0	0	0x0708

Fault reset *

Instance	Byte	15	14	13	12	11	10	9	8	7	6	5	4	3	2	1	0	Hex.
Output Instance 21	1, 0	0	0	0	0	0	0	0	0	0	0	0	0	0	1	0	0	0x0004
	3, 2	-	-	-	-	-	-	-	-	-	-	-	-	-	-	-	-	-

* Fault reset works only 1 time when 0 -> 1.

3.4.5.3. Instance 100/150 – Toshiba Specific ($F\theta 94 = 2$)

Byte	Bit 7	Bit 6	Bit 5	Bit 4	Bit 3	Bit 2	Bit 1	Bit 0
0	DC braking	ACC1/ ACC2	PI off	THR2	Preset Speed4	Preset Speed3	Preset Speed2	Preset Speed1
1	Command link *	Frequency link *	Reset trip	Emergency stop	Free run (ST)	Run/stop	Fw/ Reverse	Jog
2	Drive Reference Speed Hz (Low byte) **							
3	Drive Reference Speed Hz (High byte) **							

Fig. 5 Output Instance 100 Layout

Byte	Bit 7	Bit 6	Bit 5	Bit 4	Bit 3	Bit 2	Bit 1	Bit 0
0	DC braking	ACC2	PI	tHr2 (VF2+tH2)	-	ALARM (fc91)	EMG	FL
1	-	READY without ST/RUN	READY with ST/ RUN	Emergency stop	Free run (ST)	Run/ Stop	Fw/ Reverse	Jog
2	Drive Actual Speed Hz (Low byte)							
3	Drive Actual Speed Hz (High byte)							

Fig. 6 Input Instance 150 Layout

* Bit 14 and 15 of the instance 100 byte 0 are defined as follows.

Bit 15 (Command link)..... When "0" is set, the other command does not work except bit 12 and 13, Run/Stop is according to setup of the parameter $C\theta d$.

Bit 14 (Frequency link)..... When "1" is set, bytes 2 and 3 are enabled. When "0" is set, Drive Reference Speed is according to setup of the parameter $F\theta d$.

** Drive Reference Speed is set up by 0.01Hz unit and the hexadecimal number.

For example, when "Frequency reference" is set up to 60Hz, since the minimum unit is 0.01Hz, $60 / 0.01 = 6000 = 0x1770$ (Hex.)

Examples of Instance 100/150

Stop

Instance	Byte	15	14	13	12	11	10	9	8	7	6	5	4	3	2	1	0	Hex.
Output Instance 100	1, 0	0	0	0	0	0	0	0	0	0	0	0	0	0	0	0	0	0x0000
	3, 2	-	-	-	-	-	-	-	-	-	-	-	-	-	-	-	-	-
Input Instance 150	1, 0	0	1	0	0	1	0	0	0	0	0	0	0	0	0	0	0	0x4800
	3, 2	0	0	0	0	0	0	0	0	0	0	0	0	0	0	0	0	0x0000

Forward running 60Hz

Instance	Byte	15	14	13	12	11	10	9	8	7	6	5	4	3	2	1	0	Hex.
Output Instance 100	1, 0	1	1	0	0	0	1	0	0	0	0	0	0	0	0	0	0	0xC400
	3, 2	0	0	0	1	0	1	1	1	0	1	1	1	0	0	0	0	0x1770
Input Instance 150	1, 0	0	1	1	0	0	1	0	0	0	0	0	0	0	0	0	0	0x6400
	3, 2	0	0	0	1	0	1	1	1	0	1	1	1	0	0	0	0	0x1770

Reverse running 60Hz

Instance	Byte	15	14	13	12	11	10	9	8	7	6	5	4	3	2	1	0	Hex.
Output Instance 100	1, 0	1	1	0	0	0	1	1	0	0	0	0	0	0	0	0	0	0xC600
	3, 2	0	0	0	1	0	1	1	1	0	1	1	1	0	0	0	0	0x1770
Input Instance 150	1, 0	0	1	1	0	0	1	1	0	0	0	0	0	0	0	0	0	0x6600
	3, 2	0	0	0	1	0	1	1	1	0	1	1	1	0	0	0	0	0x1770

Preset speed 1 with forward running (5r i)

Instance	Byte	15	14	13	12	11	10	9	8	7	6	5	4	3	2	1	0	Hex.
Output Instance 100	1, 0	1	0	0	0	0	1	0	0	0	0	0	0	0	0	0	1	0x8401
	3, 2	-	-	-	-	-	-	-	-	-	-	-	-	-	-	-	-	-
Input Instance 150 (5r i is set 5Hz.)	1, 0	0	1	1	0	0	1	0	0	0	0	0	0	0	0	0	0	0x6400
	3, 2	0	0	0	0	0	0	0	1	1	1	1	1	0	1	0	0	0x01F4

Fault reset ***

Instance	Byte	15	14	13	12	11	10	9	8	7	6	5	4	3	2	1	0	Hex.
Output Instance 100	1, 0	0	0	1	0	0	0	0	0	0	0	0	0	0	0	0	0	0x2000
	3, 2	-	-	-	-	-	-	-	-	-	-	-	-	-	-	-	-	-

About the other command, refer to the Communications Function Instruction Manual (E6581222) section 8.1.

*** Fault reset works only 1 time when 0 -> 1.

3.4.5.4. Instance 101/151 – Toshiba Specific ($F B 9 4 = 3$)

Byte	Bit 7	Bit 6	Bit 5	Bit 4	Bit 3	Bit 2	Bit 1	Bit 0
0	-	Net Ref	Net Ctrl	-	-	Fault reset	Run reverse	Run forward
1	-							
2	Drive Reference Speed min^{-1} (Low byte)							
3	Drive Reference Speed min^{-1} (High byte)							
4	Index (Low byte)							
5	Write	Index (High byte)						
6	Data (Low byte)							
7	Data (High byte)							

Fig. 7 Output Instance 101 Layout

Byte	Bit 7	Bit 6	Bit 5	Bit 4	Bit 3	Bit 2	Bit 1	Bit 0
0	At reference	Ref from Net	Ctrl from Net	Ready	Running Reverse	Running Forward	Warning	Faulted/tripped
1	Drive Status							
2	Drive Actual Speed min^{-1} (Low byte)							
3	Drive Actual Speed min^{-1} (High byte)							
4	Index (Low byte)							
5	Write	Error	Index (High byte)					
6	Data (Low byte)							
7	Data (High byte)							

Fig. 8 Input Instance 151 Layout

* Drive Status is same as the Control Supervisor class State attribute (refer to 3.7.2).

- 1 (= BN: 00000001): Startup
- 2 (= BN: 00000010): Not Ready
- 3 (= BN: 00000011): Ready
- 4 (= BN: 00000100): Enabled
- 5 (= BN: 00000101): Stopping
- 6 (= BN: 00000110): Fault Stop
- 7 (= BN: 00000111): Faulted

Examples of Instance 101/151

Access the inverter parameter is enabled using byte 4 to 6 of this Instance.

Set the communication number of the parameter to byte 4, 5 (Index), and the value to byte 6, 7 (Data).

In case of the monitor parameter "FE**", the value becomes "communication number - 0xF000 (same as bit12 - 15 set to 0)".

Read the parameter $\underline{C00d}$ (Command mode selection, communication number is 0003).

Instance	Byte	15	14	13	12	11	10	9	8	7	6	5	4	3	2	1	0	Hex.
Output Instance 101	5, 4	0	0	0	0	0	0	0	0	0	0	0	0	0	0	1	1	0x0003
	7, 6	-	-	-	-	-	-	-	-	-	-	-	-	-	-	-	-	-
Input Instance 151 ($\underline{C00d}$ is set 0.)	5, 4	0	0	0	0	0	0	0	0	0	0	0	0	0	0	1	1	0x0003
	7, 6	0	0	0	0	0	0	0	0	0	0	0	0	0	0	0	0	0x0000

Read the parameter $\underline{F260}$ (Jogging frequency).

Instance	Byte	15	14	13	12	11	10	9	8	7	6	5	4	3	2	1	0	Hex.
Output Instance 101	5, 4	0	0	0	0	0	0	1	0	0	1	1	0	0	0	0	0	0x0260
	7, 6	-	-	-	-	-	-	-	-	-	-	-	-	-	-	-	-	-
Input Instance 151 ($\underline{F260}$ is set 5.0Hz.)	5, 4	0	0	0	0	0	0	1	0	0	1	1	0	0	0	0	0	0x0260
	7, 6	0	0	0	0	0	0	0	1	1	1	1	1	0	1	0	0	0x01F4

Read the parameter $\underline{FE04}$ (Voltage of DC bus).

Instance	Byte	15	14	13	12	11	10	9	8	7	6	5	4	3	2	1	0	Hex.
Output Instance 101	5, 4	0	0	0	0	1	1	1	0	0	0	0	0	0	1	0	0	0x0E04
	7, 6	-	-	-	-	-	-	-	-	-	-	-	-	-	-	-	-	-
Input Instance 151 ($\underline{FE04}$ is 97.60%.)	5, 4	0	0	0	0	1	1	1	0	0	0	0	0	0	1	0	0	0x0E04
	7, 6	0	0	1	0	0	1	1	0	0	0	1	0	0	0	0	0	0x2620

Write "60 (Hz)" to the parameter $\underline{5r1}$ (Preset speed 1, communication number is 0018).

Instance	Byte	15	14	13	12	11	10	9	8	7	6	5	4	3	2	1	0	Hex.
Output Instance 101	5, 4	1	0	0	0	0	0	0	0	0	0	0	1	1	0	0	0	0x8018
	7, 6	0	0	0	1	0	1	1	1	0	1	1	1	0	0	0	0	0x1770
Input Instance 151 (OK)	5, 4	1	0	0	0	0	0	0	0	0	0	0	1	1	0	0	0	0x8018
	7, 6	0	0	0	1	0	1	1	1	0	1	1	1	0	0	0	0	0x1770
Input Instance 151 (NG) (Error code *)	5, 4	1	1	0	0	0	0	0	0	0	0	0	1	1	0	0	0	0xC018
	7, 6	0	0	0	0	0	0	0	0	0	0	0	0	0	0	0	1	0x0001

About byte 0 - 3, refer to section 3.4.5.2.

* Refer to following about the error code.

1(= BN: 00000001):: Data out of range

2(= BN: 00000010):: Bad address

3.5. Connection Object

Class code 0x05. The Connection Class allocates and manages the internal resources associated with both I/O and Explicit Messaging Connections.

3.5.1. Connection Object Attributes

Not supported.

3.5.2. Connection Object Instance Attributes

Connection Instance ID #	Description
1	References the Explicit Messaging Connection
2	Reference the Polled I/O Connection

3.5.2.1. Explicit Messaging Connection Object Instance Attributes (Instance 1)

Attribute ID	Name	Data Type	Access Rules	Description	Default Value
1	state	USINT	Get	State of the object 00 = Non-existent 01 = Configuring 02 = Waiting for connection ID 03 = Established 04 = Timed Out 05 = Deferred Delete	-
2	instance_type	USINT	Get	Indicates connection type	0
3	transportClass_trigger	USINT	Get	Connection behavior	0x83
4	produced_connection_id	UINT	Get	Placed in CAN ID field when transmitting	0x40B*
5	consumed_connection_id	UINT	Get	CAN ID field value denoting received messages	0x40C*
6	initial_comm_characteristics	USINT	Get	Defines producing / consuming message groups	0x21
7	produced_connection_size	UINT	Get	Max number of bytes transmitted across this connection	49
8	consumed_connection_size	UINT	Get	Max number of bytes received across this connection	49
9	expected_packet_rate	UINT	Get/Set	Defines timing associated with this connection	2500
12	watchdog_timeout_action	USINT	Get/Set	Inactivity/watchdog timeout action	Auto Delete (1)
13	produced_connection_path_length	UINT	Get	Number of bytes in produced_connection_path attribute	0
14	produced_connection_path	USINT (ARRAY)	Get	Specifies Application Object(s) whose data is to be produced by this connection	Empty
15	consumed_connection_path_length	UINT	Get	Number of bytes in consumed_connection_path attribute	0
16	consumed_connection_path	USINT (ARRAY)	Get	Specifies Application Object(s) whose data is to be consumed by this connection	Empty
17	production_inhibit_time	UINT	Get	Defines minimum time between new data production	0

* connection id dependant on device Mac ID

3.5.2.2. Poll Connection Object Instance Attributes (Instance 2)

Attribute ID	Name	Data Type	Access Rules	Description	Default Value
1	state	USINT	Get	State of the object	-
2	instance_type	USINT	Get	Indicates connection type	1
3	transportClass_trigger	USINT	Get	Connection behavior	0x82
4	produced_connection_id	UINT	Get	Placed in CAN ID field when transmitting	0x3C1*
5	consumed_connection_id	UINT	Get	CAN ID field value denoting received messages	0x40D*
6	initial_comm_characteristics	USINT	Get	Defines producing / consuming message groups	0x1
7	produced_connection_size	UINT	Get	Max number of bytes transmitted across this connection	4
8	consumed_connection_size	UINT	Get	Max number of bytes received across this connection	4
9	expected_packet_rate	UINT	Get/Set	Defines timing associated with this connection	0
12	watchdog_timeout_action	USINT	Get	Inactivity/watchdog timeout action	0
13	produced_connection_path_length	UINT	Get	Number of bytes in produced_connection_path attribute	3
14	produced_connection_path	USINT (ARRAY)	Get	Specifies Application Object(s) whose data is to be produced by this connection	0x62 0x34 0x36
15	consumed_connection_path_length	UINT	Get	Number of bytes in consumed_connection_path attribute	3
16	consumed_connection_path	USINT (ARRAY)	Get	Specifies Application Object(s) whose data is to be consumed by this connection	0x62 0x31 0x34
17	production_inhibit_time	UINT	Get	Defines minimum time between new data production	0

* connection id dependant on device Mac ID

3.5.3. Connection Class Common Services

Service Code	Service Name	Supported		Description of Service
		Class	Instance	
0x05	Reset	N/A	Yes	Used to reset all resetable connection objects.
0x0E	Get_Attribute_Single	N/A	Yes	Returns the contents of the specified attribute.
0x10	Set_Attribute_Single	N/A	Yes	Modifies the value of the specified attribute.

3.5.4. Connection Class Specific Services

The Connection Class provides no object specific services.

3.6. Motor Data Object

Class code 0x28. This object serves as a database for motor parameters.

3.6.1. Motor Data Object Class Attributes

Attribute ID	Name	Data Type	Access Rules	Description	Default Value
1	Revision	UINT	Get	Revision of this object	1
2	Max instance	UINT	Get	Maximum instance number of an object currently created in this class level of the device	1

3.6.2. Motor Data Object Instance Attributes

Attribute ID	Name	Data Type	Access Rules	Description	Default Value
1	Number of Attributes	USINT	Get	Number of Attributes supported	8
2	Attributes List	USINT (ARRAY)	Get	List of attributes supported	-
3	Motor Type	USINT	Get	0 - Non-standard motor 1 - PM DC Motor 2 - FC DC Motor 3 - PM Synchronous Motor 4 - FC Synchronous Motor 5 - Switched Reluctance Motor 6 - Wound Rotor Induction Motor 7 - Squirrel Cage Induction Motor 8 - Stepper Motor 9 - Sinusoidal PM BL Motor 10 - Trapezoidal PM BL Motor	7
6	Rated Current	UINT	Get/Set	Rated Current [100mA]	-
7	Rated Voltage	UINT	Get/Set	Rated Voltage [V]	-
9	Rated Frequency	UINT	Get/Set	Rated Electrical Frequency [Hz]	-
12	Pole Count	UINT	Get	Number of poles in the motor	-
15	Base Speed	UINT	Get/Set	Nominal speed at rated frequency from nameplate [min^{-1}]	-

3.6.3. Motor Data Object Common Services

Service Code	Service Name	Supported		Description of Service
		Class	Instance	
0x0E	Get_Attribute_Single	Yes	Yes	Returns the contents of the specified attribute.
0x10	Set_Attribute_Single	N/A	Yes	Modifies the value of the specified attribute.

3.6.4. Motor Data Object Specific Services

The Motor Data Object provides no object specific services.

3.7. Control Supervisor Object

Class code 0x29. This object models all the management functions for devices within the DeviceNet "Hierarchy of Motor Control Devices". The behavior of motor control devices is described by the State Transition Diagram.

3.7.1. Control Supervisor Object Class Attributes

Attribute ID	Name	Data Type	Access Rules	Description	Default Value
1	Revision	UINT	Get	Revision of this object	1
2	Max instance	UINT	Get	Maximum instance number of an object currently created in this class level of the device	1

3.7.2. Control Supervisor Object Instance Attributes

Attribute ID	Name	Data Type	Access Rules	Description	Default Value
1	Number of Attributes	USINT	Get	Number of Attributes supported	13
2	Attribute List	USINT (ARRAY)	Get	List of attributes supported	-
3	Run 1	BOOL	Get/Set	See Run/Stop Event Matrix 00 = Stop 01 = Run	-
4	Run 2	BOOL	Get/Set	See Run/Stop Event Matrix 00 = Stop 01 = Run	-
5	Net Control	BOOL	Get/Set	Requests Run/Stop control to be local or from network. 0 = Local Control 1 = Network Control Note that the actual status of Run/Stop control is reflected in attribute 15, CtrlFromNet.	-
6	State	USINT	Get	0 = Vendor Specific 1 = Startup 2 = Not_Ready 3 = Ready 4 = Enabled 5 = Stopping 6 = Fault_Stop 7 = Faulted	-
7	Running 1	BOOL	Get	1 = (Enabled and Run1) or (Stopping and Running1) or (Fault_Stop and Running1) 0 = Other state	-
8	Running 2	BOOL	Get	1 = (Enabled and Run2) or (Stopping and Running2) or (Fault_Stop and Running2) 0 = Other state	-
9	Ready	BOOL	Get	1 = Ready or Enabled or Stopping 0 = Other state	-
10	Faulted	BOOL	Get	1 = Fault Occurred (latched) 0 = No Faults present	-
11	Warning	BOOL	Get	1 = Warning (not latched) 0 = No Warnings present	-
12	Fault Reset	BOOL	Get/Set	0->1 = Fault Reset 0 = No action	-
15	Control From Net	USINT	Get	Status of Run/Stop control source. 0 = Control is local 1 = Control is from network	-

3.7.3. Control Supervisor Object Common Services

Service Code	Service Name	Supported		Description of Service
		Class	Instance	
0x05	Reset	N/A	Yes	Used to reset all resettable connection objects.
0x0E	Get_Attribute_Single	Yes	Yes	Returns the contents of the specified attribute.
0x10	Set_Attribute_Single	N/A	Yes	Modifies the value of the specified attribute.

3.7.4. Control Supervisor Object Specific Services

The Control Supervisor Object provides no object specific services.

Run/Stop Event Matrix

Run1	Run2	Trigger Event	Run Type
0	0	Stop	No Action
0 -> 1	0	Run	Run1
0	0 -> 1	Run	Run2
0 -> 1	0 -> 1	No Action	No Action
1	1	No Action	No Action
1 -> 0	1	Run	Run2
1	1 -> 0	Run	Run1

Control Supervisor State Transition Diagram

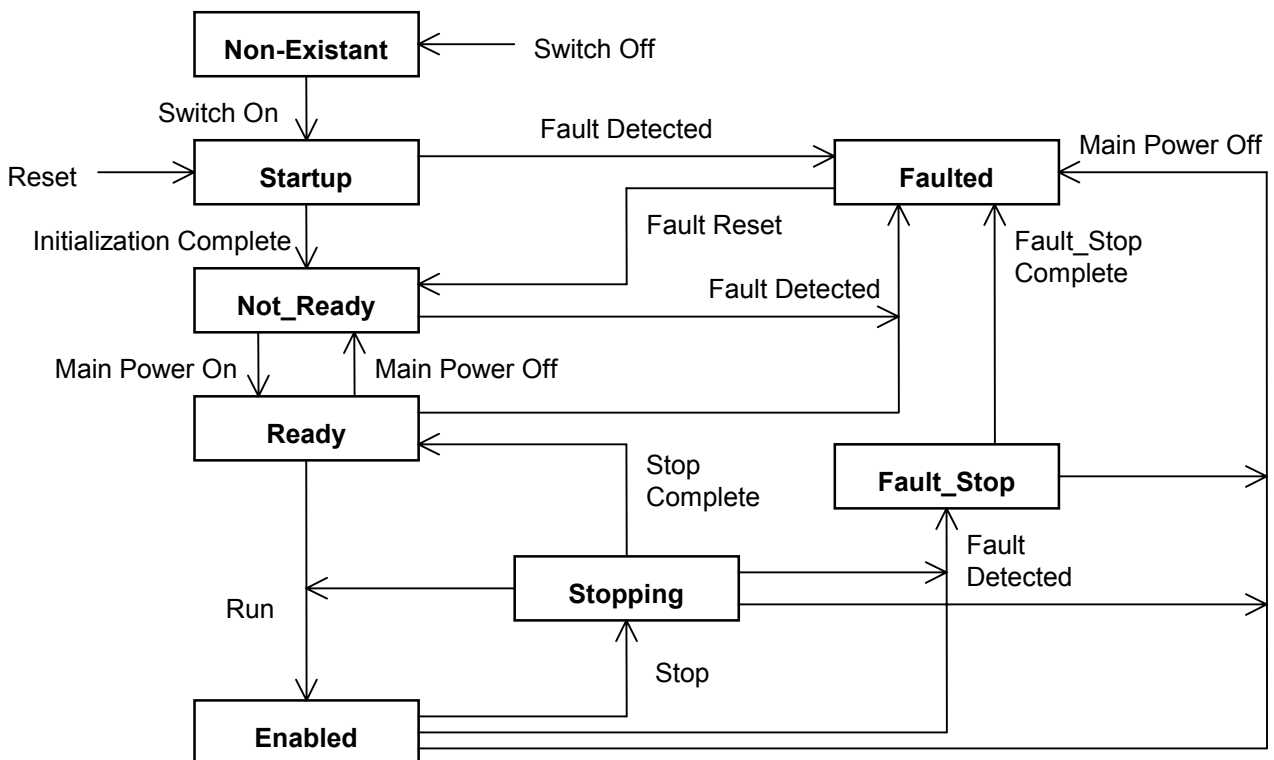

3.8. AC Drive Object

Class code 0x2A. This object models the functions specific to an AC Drive. e.g. speed ramp, torque control etc

3.8.1. AC Drive Object Class Attributes

Attribute ID	Name	Data Type	Access Rules	Description	Default Value
1	Revision	UINT	Get	Revision of this object	1
2	Max instance	UINT	Get	Maximum instance number of an object currently created in this class level of the device	1

3.8.2. AC Drive Object Instance Attributes

Attribute ID	Name	Data Type	Access Rules	Description	Default Value
1	Number of Attributes	USINT	Get	Number of Attributes supported	11
2	Attribute List	USINT (ARRAY)	Get	List of Attributes supported	-
3	At Reference	BOOL	Get	1 = Drive actual at reference (speed or torque reference) based on mode	-
4	Net Reference	BOOL	Get/Set	Requests torque or speed reference to be local or from network. 0 = Set Reference not DN Control 1 = Set Reference at DN Control Note that the actual status of torque or speed reference is reflected in attribute 29, RefFromNet.	-
6	Drive Mode	USINT	Get	0 = Vendor specific mode 1 = Open loop speed (Frequency) 2 = Closed loop speed control 3 = Torque control 4 = Process control (e.g. PI) 5 = Position control	-
7	Speed Actual	INT	Get	Actual drive speed (best approximation) Units: min^{-1}	-
8	Speed Reference	INT	Get/Set	Speed reference Units: min^{-1}	-
9	Current Actual	INT	Get	Actual motor phase current Units: 100mA	-
18	Accel Time	UINT	Get/Set	Acceleration time Time from 0 to High Speed Limit Units: ms	-
19	Decel Time	UINT	Get/Set	Deceleration time Time from High Speed Limit to 0 Units: ms	-
21	High Speed Limit	UINT	Get/Set	Maximum speed limit Units: min^{-1}	-
29	Ref From Net	BOOL	Get	Status of torque/speed reference 0 = Local torque/speed reference 1 = Devicenet torque/speed reference	-

3.8.3. AC Drive Object Common Services

Service Code	Service Name	Supported		Description of Service
		Class	Instance	
0x0E	Get_Attribute_Single	Yes	Yes	Returns the contents of the specified attribute.
0x10	Set_Attribute_Single	N/A	Yes	Modifies the value of the specified attribute.

3.8.4. AC Drive Object Specific Services

The AC/DC Drive Object provides no object specific services.

3.9. Vender Specific Device Pro-files

Class code 0x64. This object provides VF-S11's Parameter access.
All parameter's Attribute ID is 3.
Refer to the following about each parameter's Instance ID.

Example 1.

In case of Basic parameter "CMOd - Command mode selection",
Communication No: **0003** -> Instance ID: **1003**

Example 2.

In case of Extended parameter "F300 - PWM carrier frequency",
Communication No: **0300** -> Instance ID: **1300**

Example 3.

In case of Monitor parameter "FE03 - Output current",
Communication No: **FE03** -> Instance ID: **1E03**

* Monitor parameter can access "Get" only.

3.10. About EDS-file

Even if access to each parameter of VF-S11 uses a configuration tool and an EDS file, it is possible. As for acquisition of an EDS file, it is possible to download from homepage of our company.

Please use what was in agreement with the software version of usage's VF-S11.

<http://www.inverter.co.jp/product/inv/vfs11/dev/>