

# Reference Guide for the Model RT210/RT211 ISDN Routers

## **NETGEAR**

**NETGEAR**, Inc.  
A Bay Networks Company  
48015 Warm Springs Blvd.  
Fremont, CA 94539  
USA

Part No. M-RT210NA-0  
August 1996

© 1996 by NETGEAR, Inc. All rights reserved.

## Trademarks

NETGEAR, FirstGear, Nautica, and Bay Networks are trademarks of Bay Networks, Inc.

Other brand and product names are registered trademarks or trademarks of their respective holders.

## Statement of Conditions

In the interest of improving internal design, operational function, and/or reliability, NETGEAR reserves the right to make changes to the products described in this document without notice.

NETGEAR does not assume any liability that may occur due to the use or application of the product(s) or circuit layout(s) described herein.

## Federal Communications Commission (FCC) Statement

Note: This equipment has been tested and found to comply with the limits for a Class B digital device, pursuant to Part 15 of the FCC rules. These limits are designed to provide reasonable protection against harmful interference when the equipment is operated in a commercial environment. This equipment generates, uses, and can radiate radio frequency energy. If it is not installed and used in accordance with the instruction manual, it may cause harmful interference to radio communications. Operation of this equipment in a residential area may cause harmful interference, in which case users will be required to take whatever measures may be necessary to correct the interference at their own expense.

## EN 55 022 Declaration of Conformance

This is to certify that the Bay Networks NETGEAR Model RT210 and Model RT211 ISDN routers are shielded against the generation of radio interference in accordance with the application of Council Directive 89/336/EEC, Article 4a. Conformity is declared by the application of EN 55 022 Class A(CISPR 22).



**Warning:** This is a Class A product. In a domestic environment, this product may cause radio interference, in which case, the user may be required to take appropriate measures.

---

## Bestätigung des Herstellers/Importeurs

Es wird hiermit bestätigt, daß das NETGEAR Model RT210 and Model RT211 ISDN routers gemäß der im BMPT-AmtsblVfg 243/1991 und Vfg 46/1992 aufgeführten Bestimmungen entstört ist. Das vorschriftsmäßige Betreiben einiger Geräte (z.B. Testsender) kann jedoch gewissen Beschränkungen unterliegen. Lesen Sie dazu bitte die Anmerkungen in der Betriebsanleitung.

Das Bundesamt für Zulassungen in der Telekommunikation wurde davon unterrichtet, daß dieses Gerät auf den Markt gebracht wurde und es ist berechtigt, die Serie auf die Erfüllung der Vorschriften hin zu überprüfen.

Die Erfüllung der zutreffenden Vorschriften hängt von der Benutzung geschirmter Kabel ab. Der Benutzer ist für den Erwerb der entsprechenden Kabel verantwortlich.

---

## **Certificate of the Manufacturer/Importer**

It is hereby certified that the NETGEAR Model RT210 and Model RT211 ISDN routers have been suppressed in accordance with the conditions set out in the BMPT-AmtsblVfg 243/1991 and Vfg 46/1992. The operation of some equipment (for example, test transmitters) in accordance with the regulations may, however, be subject to certain restrictions. Please refer to the notes in the operating instructions.

Federal Office for Telecommunications Approvals has been notified of the placing of this equipment on the market and has been granted the right to test the series for compliance with the regulations.

Compliance with the applicable regulations is dependent upon the use of shielded cables. It is the responsibility of the user to procure the appropriate cables.

### **VCCI-2**

This equipment is in the 2nd Class category (information equipment to be used in a residential area or an adjacent area thereto) and conforms to the standards set by the Voluntary Control Council For Interference by Data Processing Equipment and Electronic Office Machines aimed at preventing radio interference in such residential area.

When used near a radio or TV receiver, it may become the cause of radio interference.

Read instructions for correct handling.

---

# Contents

## Preface

Purpose .....	xv
Audience .....	xv
Conventions .....	xvi
Special Message Formats .....	xvi
Use of Enter, Type, and Press .....	xvi
Other Conventions .....	xvii
Related Publications .....	xvii
Customer Support .....	xviii
World Wide Web .....	xviii

## Chapter 1

### Introduction

About the Router .....	1-1
Features .....	1-1
Key Features .....	1-2
ISDN Support .....	1-3
Multilink PPP Support .....	1-3
TCP/IP Support .....	1-3
Management Support .....	1-3
Planning Considerations .....	1-4
Basic Concepts .....	1-4
What Is a Router? .....	1-4
Routing Information Protocol .....	1-5
Routing Updates .....	1-5
Connecting to ISDN .....	1-6
Using Subaddressing and Multiple Subscriber Numbering .....	1-7
Using TCP/IP .....	1-7

Using PPP to Connect to Other Devices .....	1-7
Multilink PPP .....	1-7
Password Authentication Protocol .....	1-8
Challenge Handshake Authentication Protocol .....	1-8
Defining Security Levels .....	1-8

## **Chapter 2**

### **Installing and Connecting**

Package Contents .....	2-1
Site Preparation .....	2-2
Checklists .....	2-2
ISDN Services Checklist .....	2-3
European Services .....	2-3
North American Services .....	2-3
Network Checklist .....	2-4
Installing and Connecting the Router .....	2-4
Connecting to ISDN .....	2-7
Connecting to ISDN in North America .....	2-8
U Interface .....	2-8
S/T Interface .....	2-8
Connecting to a Hub .....	2-10
Power Connection .....	2-11
Using the FirstGear ISDN Router Configuration Utility .....	2-12
Connecting Through a Serial Port or a Telnet Connection .....	2-12
Connecting Through a Serial Port .....	2-13
Connecting Through a Telnet Connection .....	2-13

## **Chapter 3**

### **Configuring the Router**

Configuration Methods .....	3-1
Using the Commands in the Interface .....	3-2
Using the Built-in Interface Quick Setup .....	3-4
Using the Built-In Interface Basic Setup .....	3-7
Naming the Router .....	3-8
Entering the Network Address .....	3-8
Configuring the ISDN Line .....	3-9

Connecting to Another NETGEAR or Bay Networks Nautica Router .....	3-10
Connecting to a Router Using Point-to-Point Protocol .....	3-11
Configuring a PPP Path .....	3-12
Verifying Autocall Operation .....	3-13
Operating with a Single IP Address .....	3-14
Caller Line Identification (CLI) .....	3-14
Obtaining Additional Bandwidth .....	3-14
Subaddressing and Multiple Subscriber Numbering (MSN) .....	3-15

**Chapter 4**  
**Menus and Commands**

Using the Menu .....	4-1
Using the CONFIG Command .....	4-4
Using the Update System Parameters Form .....	4-5
Using the Configure Paths Menu .....	4-6
Using the Update Path Form .....	4-7
Using the Configure Ports Menu .....	4-11
Using the Update Ports Form .....	4-11
Using the Configure IP Routes Menu .....	4-13
Using the Update IP Routes Form .....	4-14
Using the Update PPP Custom Parameters Menu .....	4-14
Using the STATS Command .....	4-16
Viewing the Status/Statistics Menu .....	4-16
Viewing Path Status .....	4-17
Viewing IP Status .....	4-18
Viewing the ARP List .....	4-18
Viewing ISDN Port Status .....	4-19
Viewing ISDN Call History .....	4-19
Using the TELNET Command .....	4-20
Using the PING Command .....	4-20
Using the QUIT Command .....	4-21

**Chapter 5**  
**Troubleshooting**

Using the Trace Window to Display System Messages .....5-1  
Understanding the ISDN Clearing Codes .....5-2  
Troubleshooting Your ISDN Line .....5-4  
Using the Ping Utility to Troubleshoot a TCP/IP Network .....5-5  
    Testing the LAN Path to Your Router .....5-5  
    Testing the Path from Your Router to a Remote Device .....5-6  
    Testing the Full Path from Your PC to a Remote Device .....5-8  
Testing the Voice Port .....5-8

**Appendix A**  
**Technical Specifications**

General Specifications ..... A-1

**Appendix B**  
**TCP/IP Routing**

IP Addressing ..... B-1  
Subnet Addressing ..... B-3  
Address Resolution ..... B-4  
Routing IP Over ISDN ..... B-5  
Connecting to Other Routers ..... B-6

**Appendix C**  
**Ordering ISDN Lines**

Ordering an ISDN Line ..... C-1  
Connecting Devices to a Basic Rate ISDN ..... C-1  
Connecting to ISDN in North America ..... C-2  
    Directory Numbers and SPIDs ..... C-2  
        Switch Types ..... C-3  
    National ISDN Service Packages ..... C-4  
        Hunt Groups ..... C-5  
        Long Distance Service ..... C-5  
Connecting to ISDN in Europe ..... C-6  
Line Ordering Summary for North American Users ..... C-6  
Line Ordering Summary for European Users ..... C-7



**Appendix D**  
**Upgrading Software**

Obtaining the Latest Version of Software ..... D-1  
Upgrading Through a PC ..... D-2  
Upgrading Through a Remote Router ..... D-3  
Upgrading the Terminal Adapter Code ..... D-4

**Appendix E**  
**PPP Authentication Profiles**

Determining PPP Profiles ..... E-1

**Glossary**

**Index**



# Figures

Figure 2-1.	Router connections .....	2-6
Figure 2-2.	Connecting the NETGEAR Model RT210 router to ISDN in North America .....	2-9
Figure 2-3.	Router connected to a hub .....	2-10
Figure 2-4.	NETGEAR ISDN router .....	2-11
Figure 4-1.	Main Menu .....	4-2
Figure 4-2.	Built-in interface menu hierarchy .....	4-3
Figure 4-3.	Configuration Menu .....	4-4
Figure 4-4.	Status/Statistics Menu .....	4-16
Figure B-1.	Three main address classes .....	B-2
Figure B-2.	Example of Class B address .....	B-3



# Tables

Table 2-1.	Router LED .....	2-12
Table 3-1.	Key character commands .....	3-2
Table 3-2.	Task commands .....	3-2
Table 3-3.	Control character commands .....	3-3
Table 3-4.	IP address and netmask format .....	3-5
Table 5-1.	ISDN clearing codes .....	5-2
Table 5-2.	ISDN internal clearing codes .....	5-3
Table E-1.	PPP authentication profiles .....	E-2
Table E-2.	PPP authentication profiles for NETGEAR, Nautica, and Bay products .....	E-2
Table E-3.	PPP custom authentication profiles for NETGEAR, Nautica, and Bay products .....	E-3
Table E-4.	PPP authentication profiles for other manufacturers .....	E-4



# Preface

Congratulations on your purchase of the NETGEAR™ Model RT210 ISDN router or the Model RT211 ISDN router. The routers are part of the NETGEAR 200 Series router product family.

The Model RT210 and Model RT211 routers provide connection for one or more computer workstations to the Internet or to the office over inexpensive ISDN lines. The routers operate at a speed of up to 512 kilobytes per second (KBps) or 128 KBps without compression, and can download video clips, music, or high-resolution color graphics from the World Wide Web or other online services many times faster than a modem. The routers support concurrent data and voice communications, reducing cost and administration of multiple phone lines.

## Purpose

This guide describes the features of both routers and provides instructions on how to install and configure them.

## Audience

To configure and install these products, you should have the following background and experience:

- Working knowledge of basic network management concepts and terminology
- Working knowledge of tools and procedures for installing and operating sensitive electronic equipment

## Conventions

This section describes the conventions used in this guide.

### Special Message Formats

This guide uses the following formats to highlight special messages:



**Note:** This format is used to highlight information of importance or special interest.

---



**Caution:** This format is used to highlight information that will help you prevent equipment failure or loss of data.

---



**Warning:** This format is used to highlight material involving possibility of injury or equipment damage.

---



**Warning:** This format is used to alert you that you may incur an electrical shock by mishandling equipment.

---

### Use of Enter, Type, and Press

This guide uses “enter,” “type,” and “press” to describe the following actions:

- When you read “enter,” type the text and press the Enter key.
- When you read “type,” type the text, but do not press the Enter key.
- When you read “press,” press only the alphanumeric or named key.



## Other Conventions

This guide uses the following typographical conventions:

<i>italics</i>	Book titles and UNIX file, command, and directory names.
<code>courier font</code>	Screen text, user-typed command-line entries.
Initial Caps	Menu titles and window and button names.
[Enter]	Named keys in text are shown enclosed in square brackets. The notation [Enter] is used for the Enter key and the Return key.
[Ctrl]+C	Two or more keys that must be pressed simultaneously are shown in text linked with a plus (+) sign.
ALL CAPS	DOS file and directory names.

## Related Publication

For more information about configuring the NETGEAR Model RT210 and Model RT211 ISDN routers using FirstGear™, refer to *Getting Started Using FirstGear* (part number M1-RT210NA-0).

## **Customer Support**

For assistance with installing and configuring your NETGEAR system or with post-installation questions or problems, contact your point of purchase representative.

To contact customer support or to purchase additional copies of this document and publications for other NETGEAR products, you can contact NETGEAR at the following numbers:

- Phone:
  - U.S./Canada: 1-800-211-2069
  - Japan: 0031-1-26133
  - Germany: 0130-8-23776
- Fax:
  - U.S./Canada: 510-498-2609

## **World Wide Web**

NETGEAR maintains a World Wide Web Home Page that you can access at the universal resource locator (URL) <http://NETGEAR.baynetworks.com/home>. A direct connection to the Internet and a Web browser such as Mosaic or Netscape are required.

---

# Chapter 1

## Introduction

This chapter describes the features of the NETGEAR Model RT210 and Model RT211 ISDN routers and discusses planning considerations for installation.

### About the Router

The Model RT210 and Model RT211 routers are remote routers that transport data from one network to another through wide area connections.

The router compares the network addresses of data packets sent through the LAN to the entries in its address tables. If a match is found for the destination network, the router passes the packet to the path indicated by the entry in the routing table.

The entry in the path list contains the ISDN number(s) of the target router. The router sends the number to the ISDN port for the call to be connected. The path is established and the data is sent to the remote unit. At the receiving end, the process operates in the reverse order, from the wide area port to the LAN port.

### Features

The Model RT210 and Model RT211 routers are flexible, high performance, easy-to-use routers that provide a cost effective solution for intelligent networking across an ISDN line. With minimum setup, you can install and use the routers within minutes to meet a wide variety of networking requirements.

## **Key Features**

The NETGEAR Model RT210 and Model RT211 ISDN routers provide the following features:

- Standard Basic Rate ISDN Connection
  - ISDN, 2B+D providing 2 x 64 Kbps data channels and a 16 Kbps control channel
  - Four-wire S/T interface on NETGEAR Model RT210
  - Two-wire U interface on Model RT211
- Protocol Support
  - IP routing
  - Bandwidth-on-demand with Multilink Point-to-Point Protocol
- Security
  - Access control on management functions
  - Dial-in access control by Calling Line Identification (CLI)
  - PAP and CHAP authentication support
- Management
  - Local terminal management through:
    - Easy-to-use FirstGear menu driven management software for PC users
    - Built-in screen-based interface software for Mac, UNIX, and PC users
  - Direct status and statistics reporting with simple configuration capability
  - Accessible from networked TCP/IP stations by Telnet
- Analog Voice Module
  - Provides a single RJ-11 interface
  - Allows a standard analog public switched telephone network (PSTN) device, for example, a telephone, fax, or modem, to make and receive calls to or from other ISDN or PSTN connected devices
  - Eliminates the need for a separate PSTN line in a small office/home office environment

## **ISDN Support**

The Model RT210 and Model RT211 routers are designed to take advantage of ISDN for transmission of data over digital telephone networks. ISDN allows the telephone networks to carry data, voice, and video along the same cables. A Basic Rate Interface (BRI), which is the usual ISDN implementation, consists of 2 x 64 KBps B channels for data, and a 16 KBps D channel for control information.

One advantage of using ISDN to connect routers is that the connection is set up only if there is data to be sent to the remote network. The NETGEAR Model RT210 and Model RT211 ISDN routers detect that a network exists on a remote unit that can be reached through ISDN. The routers set up a call, transfer the data, and then hang up automatically when the connection is no longer needed.

## **Multilink PPP Support**

When the single channel ISDN line utilization exceeds a configurable threshold, the NETGEAR Model RT210 and Model RT211 ISDN routers can automatically establish an additional ISDN call to provide additional bandwidth. During heavy traffic, the two 64 KBps B channels are combined using Multilink PPP to provide a fast 128 KBps pipe. When traffic slows down, one of the B-channels is idled to save toll charges. The router also reverts back to one B-channel for data when the analog port is used.

## **TCP/IP Support**

The routers support TCP/IP protocol, Routing Information Protocol (RIP), and RIP2 routing protocols and ensure that ISDN connections are established only when passing data.

For get further information about TCP/IP before installing your router, refer to [Appendix B, “TCP/IP Routing.”](#)

## **Management Support**

The Model RT210 and Model RT211 routers are designed to be installed and made operational within minutes after connection to the network.

If you are a PC user, the FirstGear software lets you easily configure the unit from the Windows environment.

If you are a MAC, UNIX, or PC user, you can connect to the built-in interface which can be accessed through a terminal connected to the Manager port or through a Telnet session across the network. The built-in interface manages and configures the unit through an easily understood screen process.

You can download software upgrades across an ISDN connection from another NETGEAR ISDN router or from a personal computer. For further information, refer to [Appendix D, “Upgrading Software.”](#)

## **Planning Considerations**

This section helps you plan the setup of the Model RT210 and Model RT211 routers.

### **Basic Concepts**

The cost of installing and running a network and providing sufficient bandwidth to communicate has generally been proportional to the distance that the network extends and the amount of bandwidth required. Large amounts of bandwidth can be provided easily and relatively inexpensively in a local area network. However, interconnecting local networks at similar speeds is very expensive because of the cost of installing the infrastructure that can provide that level of bandwidth.

Usually, slower speed links are used to interconnect local high speed networks. Devices at either end can select the traffic that uses the slower wide area links and determine exactly where it is sent. This ensures maximum throughput over the slower link. This process is known as routing.

Techniques for routing data between high speed local area networks (LANs) over slower speed wide area networks (WANs) have evolved over the years, and use various mediums and protocols. The ability to uniquely identify the source and destination of the data is critical to allow any operations to be successful across the WAN link.

### **What Is a Router?**

A router is a device designed to deliver data from the source network to the correct destination network. After the data has reached the correct network, the task of the router is to ensure that it reaches the correct station on that network. Most routing environments have a method for uniquely identifying each destination, which in most cases is a network number and a station or node number. This method is very similar to the method used by the post office to send mail to your home when it is addressed to you at your street name, town, state, and country.

To work effectively, routers gather information about the networks connected to them and update the other routers on the network with this information. In this way they build up a logical picture of the network, known as a routing table, and work out the quickest route to other networks.

## **Routing Information Protocol**

One of the protocols used to build and maintain this picture of the network is the Routing Information Protocol (RIP). The RIP is a distance vector protocol, which means that all the decisions about which path to use are based upon distance between source and destination. A router using RIP would first look at directly attached networks. These networks would be considered to be one hop away. Other networks that are not directly attached would be multiple hops away. When there are multiple paths to a network, the path with the least number of hops is chosen and is regarded as the best path. All other information about how to get to that network is discarded.

Using RIP, the routers update each other every 30 seconds and check to see whether there is any new information that should be added to the routing table. The entries in a routing table are allowed to remain for 180 seconds. If no information about a remote network is received in this time, the destination network is deemed to be unreachable and removed from the routing table.

An important consideration is how long it takes for a change to the routing topology, which is typically a link or node failure, to be propagated throughout the entire RIP environment. This process is called convergence. It is important that it occur as fast as possible so that all routers have correct information about the changed network in their tables. With RIP, convergence takes place 1 hop at a time throughout the entire network. In using the 30 second routing information timer, the routers pass information from one hop to another. To prevent the information that is being passed from being excessively long, RIP is limited to 15 hops maximum.

The NETGEAR Model RT210 and Model RT211 ISDN routers support both RIP and RIP2. RIP2 has a number of enhancements, including the ability to transmit subaddress information with the routing table, allowing networks with variable length subnetwork numbers to be supported.

## **Routing Updates**

As can be seen from the previous routing protocol descriptions, routing updates are broadcast on a regular basis. This process works well with leased circuit or permanent connections, where the circuit is either functioning by passing data and routing updates, or not functioning, in which case routing updates are not received. In this case, a time-out mechanism removes the relevant routes from the routing table after no updates have been received for a defined period.

Using ISDN as the connection medium adds another circuit state to the equation. The connection can be functioning, but no data or routing updates are being passed because the call is currently closed. If this state exists longer than the routing protocol time-out (normally 3 minutes), the routes would decay and be removed from the tables at each end of the link. If this happens, routing could not take place between the units at either end of the ISDN link.

To overcome this problem, the NETGEAR Model RT210 and Model RT211 ISDN routers automatically treat routes learned over ISDN as semipermanent. They are not decayed and can be updated by any received routing protocol updates if any of the hop counts have changed since the last update.

Another issue concerning passing routing updates across ISDN is whether a call is made or left connected for the sole purpose of passing routing information. The NETGEAR routers do not make calls specifically for passing routing updates. The next user data call includes the routing update information that was copied to the local routing table when the connection was closed. Therefore, a call that has been made for data transfer is not kept open by routing updates because these are not included in the idle calculation for that call.

## **Connecting to ISDN**

When you connect to ISDN, there are several important things you must know in order to make the correct decisions in placing your order and configuring your router.

When you order the ISDN line from your telephone company, you must know what type of ISDN service your telephone company provides so that you can configure your router properly. Your telephone company might provide you with Service Profile Identifiers (SPIDs) along with the ISDN telephone numbers. You need to know the SPIDs, if you are given them, and the ISDN telephone number(s) before setting up the router.

In most areas, your ISDN equipment is connected to the telephone company by a four-wire S/T interface, such as the one provided by the Model RT210 router. The telephone company provides a network termination device commonly known as an NT1, which converts this four-wire S/T interface to a two-wire U interface for transmission over long lines to the central switch. In North America, the customer is expected to provide an NT1. For this reason, the Model RT211 ISDN router integrates the function of the NT1, reducing cost and wiring complexity.

For more information, refer to Appendix C, “Ordering ISDN Lines.”



## Using Subaddressing and Multiple Subscriber Numbering

If the NETGEAR Model RT210 router shares an ISDN line with other ISDN devices, the router must identify and route incoming calls. You can use either subaddressing or Multiple Subscriber Numbering (MSN) as ways to identify where the incoming calls belong. These options are enabled only by the ISDN providers. For further information on subaddressing and MSN, refer to [“Subaddressing and Multiple Subscriber Numbering \(MSN\)”](#) on [page 3-15](#).

## Using TCP/IP

The network or subnetwork numbers must be different at each end of a link for the routers to function correctly. If several routers are connected to the same LAN segment, they should have the same network or subnetwork numbers, but different host numbers. Using TCP/IP, you can assign addresses to assure proper routing.

For more information, refer to Appendix B, “TCP/IP Routing.”

## Using PPP to Connect to Other Devices

The Point to Point Protocol (PPP) was designed to allow interoperability between networking equipment of different manufacturers at a basic level. Because of the many different implementations of the standard, you might need to try a number of configuration options before communication can be established.

The NETGEAR Model RT210 and Model RT211 ISDN routers have several preconfigured profiles, but can be changed when full configuration of all the PPP options is needed.

### Multilink PPP

When a path is configured for PPP, Additional Bandwidth on Demand can be enabled only if Multilink PPP is available on the remote unit.

Multilink PPP (MP) is an addition to the basic PPP protocol that allows more than one link to be directed to a destination. If a unit supports the MP protocol, then it can be negotiated automatically on the initial link startup. When additional Bandwidth on Demand calls are made, the extra bandwidth is made available to the path.



**Note:** When you are using the PPP profile “SIMPLE” MP is disabled.

---

## **Password Authentication Protocol**

The Password Authentication Protocol (PAP) is the simplest method of enabling security on PPP links. When the link is being set up, the Peer (caller) sends its Name and Password to the Authenticator. If the Name and Password match the values stored by the Authenticator, the connection is allowed to proceed.

## **Challenge Handshake Authentication Protocol**

The Challenge Handshake Authentication Protocol (CHAP) is a more complex method of security. The Authenticator challenges the Peer, which responds with the output of an algorithm based on the CHAP Secret and the CHAP Name (the Name of the Path).

The Authenticator verifies the output by using its CHAP Secret configured on the path CHAP Name as the key for the algorithm. The Authenticator checks that the output value it calculates is the same as the one received from the Peer. If the challenge is responded to correctly, the connection is allowed to proceed. Because the CHAP Secret itself is never sent across the link, it cannot be discovered by anyone monitoring the line.

## **Defining Security Levels**

Because ISDN is a public service, it opens your network to unauthorized access and security becomes an important issue. The NETGEAR Model RT210 and Model RT211 ISDN routers are equipped with the following features designed to maintain security:

- Caller Line Identification (CLI or Caller ID) ensures that incoming ISDN calling numbers are checked before access is granted.
- When PPP is the link protocol for connecting to third-party routers, you can use either Password Authentication Protocol (PAP) or Challenge Handshake Authentication Protocol (CHAP).
  - PAP improves security by requesting that a password be sent by the caller.
  - CHAP, a more complex method of security, checks the authenticity of the password without sending it across the link.

---

## Chapter 2 Installing and Connecting

This chapter provides instructions on installing the Model RT210 or Model RT211 router and connecting to the built-in interface through a serial or Telnet connection.

If you are a PC user, you can configure the router either by an easy-to-use software program, the FirstGear ISDN router configuration utility, or the built-in interface. For complete instructions on using FirstGear, refer to *Getting Started Using FirstGear*.

If you are using a Macintosh or UNIX-based workstation, you can configure the router only by using the built-in interface. However, you can connect a PC to your router and use FirstGear for the configuration process. After configuration is complete, connect the router back to your Macintosh for normal operation. For complete instructions on using FirstGear, refer to *Getting Started Using FirstGear*.

For further information on the different methods for configuring your router, refer to [“Configuration Methods”](#) in [Chapter 3, “Configuring the Router.”](#)

### Package Contents

The product package should contain the following items:

- NETGEAR Model RT210 or Model RT211 ISDN router
- AC Power Adapter 9V-DC output
- Two 10 foot 10BASE-T Ethernet cables (round)
- 10 foot ISDN cable (flat)
- 9-pin D-connector to RJ-45 cable adapter

- 9-pin D-connector to 25-pin D-connector adapter
- RJ-45 two-way splitter
- This guide
- *Getting Started Using FirstGear*
- Two 3.5-inch FirstGear installation diskettes
- Four rubber feet
- Four Velcro feet
- Two Velcro pads
- Warranty/Registration card

Call your dealer if there are any wrong, missing, or damaged parts. Keep the carton, including the original packing materials, to repack the router if there is a need to return it for repair.

## Site Preparation

Before you begin installing the router, prepare the installation site. Make sure the operating environment meets the physical requirements of the router. The ambient temperature must be between 0° C and 40° C. The maximum relative humidity must not exceed 90%.

The router should be installed on a flat surface in a clean, dry location. You should ensure that all units to be connected are within reach of the cables and power and that all are functioning correctly.

## Checklists

Check the following ISDN Service Checklist and Network Checklist to make sure that all requirements are met and that your network is properly configured.

## ISDN Services Checklist

The following requirements must be met if you connect your router to other routers through ISDN.

### European Services

- Your ISDN circuit should conform to EURO-ISDN, NET3, or I-CTR3 standards.
- You should know the ISDN number(s) of your local and remote sites.
- If you require CLI (Caller Line Identification) for security, order the CLI option from your local carrier.
- If possible, place your order so that both B channels have the same ISDN number. Giving both B channels the same ISDN number, which is known as auxiliary working, can speed up connect times.

### North American Services

In North America, you must configure your ISDN ports on the NETGEAR Model RT210 and Model RT211 ISDN routers according to the type of switch your telephone company has in its local central office. For further information, refer to [Appendix C, “Ordering ISDN Lines.”](#)

You need the following information from your telephone company:

- The type of switch at your telephone company  
Either AT&T 5ESS, Northern Telecom DMS-100, Northern Telecom DMS-250, or Siemens EWSD.
- Configuration mode of your ISDN line  
Whether your line is configured in the standard National ISDN mode, or whether it is configured in a manufacturer-specific custom mode.
- Directory number(s) that you are assigned  
The local directory number(s) assigned to the line.
- Service Profile Identifiers (SPIDs) assigned to your devices  
The SPIDs associated with the directory numbers.

## Network Checklist

Networks connected through the router must be properly configured. The Model RT210 and Model RT211 routers route through TCP/IP protocol only.

The TCP/IP configuration requirements are:

- All of your host devices must have established IP addresses.

These addresses are usually provided by your network administrator or Internet provider.

- An IP address must be assigned to your router.

The address is usually provided by your network administrator or Internet provider.

- Your router definition must be set.

If any devices are not running either TCP/IP or a compatible protocol, have the router defined as either the default gateway or as an entry in the static routes table of the device.

- Your network or subnetwork numbers must be different on the local and remote networks you are routing between.

## Installing and Connecting the Router

You can install the NETGEAR Model RT210 and Model RT211 ISDN routers on a flat surface, such as a tabletop or desktop, or you can mount them on a computer housing or wall using the Velcro strips.

Rubber feet are provided to install the router on a flat surface. The Velcro pads are provided to attach the router to the side of your workbench or PC.

To install your router, follow these steps:

1. **Unpack your router and verify that all the necessary parts are present (refer to [“Package Contents”](#) earlier in this chapter).**

2. **Apply the appropriate feet (rubber or Velcro) to the bottom of your router as follows:**
  - a. **Peel the back from each foot.**
  - b. **Apply one to each of the four marked locations on the bottom of your router.**
  - c. **If installing Velcro, clean the surface of the workbench or PC where your router is to be attached.**
  - d. **Peel the backing from the two Velcro pads and press them firmly in place.**
  - e. **Align the Velcro pads on your router to the two Velcro pads on the workbench or PC and press firmly to attach the unit.**

[Figure 2-1](#) illustrates the router connected to ISDN (8); to a telephone, which is an analog device (6); to the power adapter (5); and to a computer through a serial connection (11) and a LAN connection (12).

The steps following the figure give you detailed instructions for making these connections.

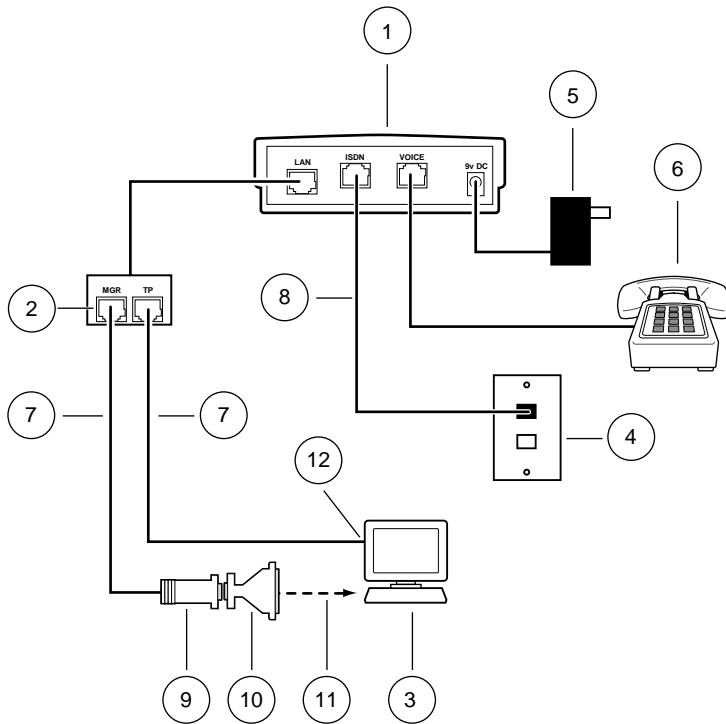

7289

Key:

- 1 Router
- 2 RJ-45 two-way splitter
- 3 Station (PC, Macintosh, or UNIX workstation)
- 4 ISDN wall connection
- 5 AC power adapter
- 6 Analog device (telephone, fax, or modem)
- 7 10BASE-T Ethernet cable (10-ft round cable)
- 8 ISDN cable (10-ft flat cable)
- 9 9-pin D-connector to RJ-45 cable adapter
- 10 9-pin D-connector to 25-pin D-connector (if necessary)
- 11 Serial connection on the PC
- 12 LAN connection on the PC

**Figure 2-1. Router connections**



3. **Connect the cables and power to the appropriate ports on the back panel of the router, as illustrated in [Figure 2-1](#):**
  - a. **Connect the AC power adapter (5) to the 9v-DC port.**
  - b. **Connect the ISDN cable (8) to the ISDN port.**
  - c. **Connect the RJ-45 two-way splitter (2) to the LAN port.**
  - d. **Connect an appropriate cable to connect an analog device (6) (phone, fax, or modem) to the Voice port.**
4. **Connect one of the two Ethernet 10BASE-T cables (7) to the MGR port on the RJ-45 two-way splitter (2).**
5. **Connect the other end of the 10BASE-T cable that you used in step 4 to the 9-pin D-connector to RJ-45 adapter (9).**
6. **Connect the 9-pin D-connector to RJ-45 adapter (9) to the serial port of your PC.**

Depending on what type of computer you are using, you may have to connect the 9-pin D-connector to 25-pin D-connector (10) next or supply an adapter of your own to be able to connect to the serial port of your PC.
7. **Connect the other Ethernet 10BASE-T cable (7) to the TP port on the RJ-45 two-way splitter (2).**
8. **Connect the other end of the Ethernet 10BASE-T cable (7) that you used in step 6 to the LAN port (12) on your PC.**

## Connecting to ISDN

To connect your router to ISDN outside of North America, follow these steps:

1. **Connect the ISDN cable (8) from the router to the ISDN wall outlet (4) ([Figure 2-1](#)).**



**Warning:** Do not plug the ISDN cable into the LAN port on the router. Plugging the ISDN cable into the LAN port causes serious damage to the router.

---

## Connecting to ISDN in North America

Your location is connected to the central switch at the telephone company by a two-wire U interface, like the interface that is provided on the Model RT211 ISDN router.

If the Model RT210 ISDN router or any device that does not have a U interface is connected to an ISDN line, the interface must be converted by using a network termination unit, known as an NT1. The NT1 converts the S/T four-wire interface of the RT210 to a two-wire U interface.

### ***U Interface***

If you have purchased a NETGEAR Model RT211 ISDN router, which has a U interface connection, you can connect to your ISDN line by connecting the flat ISDN cable from the ISDN wall outlet into the port marked ISDN on the RT211 (refer to [Figure 2-1](#)). Your ISDN wall outlet can be set up to accommodate either an RJ-11 or RJ-45 connector.

### ***S/T Interface***

If you have purchased a NETGEAR Model RT210 ISDN router, which has an S/T interface connection, you need an external NT1 to convert the S/T to a U interface.

To connect the ISDN line into the router (refer to [Figure 2-2](#)), follow these steps:

1. **Connect the ISDN ribbon cable (2) from the ISDN S/T interface (3) on the NT1 device (5) into the ISDN port on the router.**



**Warning:** Some NT1s provide 48 V DC on pins 7 and 8 of the terminal connector to power ISDN telephones. Plugging the cable from an NT1 into the LAN port causes serious damage to the router.

---

2. **Connect an ISDN cable from the ISDN wall outlet (6) to the U interface (4) on the NT1 device (5) .**
3. **Connect the NT1 device (5) to the AC power and turn the power on.**

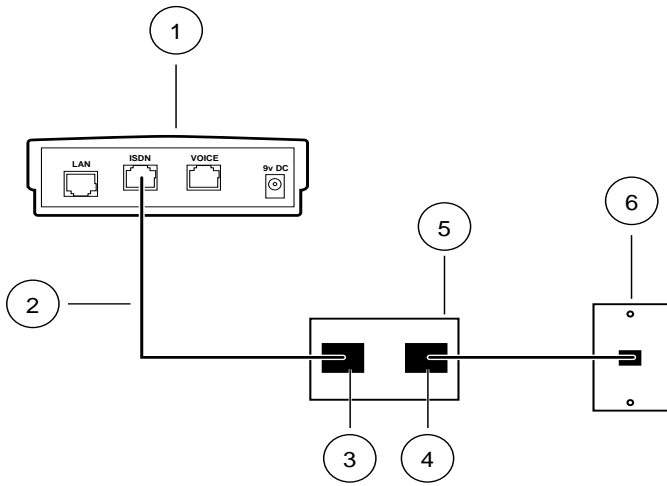

7288

Key:

- 1 Model RT210 ISDN router
- 2 ISDN cable
- 3 S/T interface
- 4 U interface
- 5 NT1 device
- 6 ISDN wall connection

**Figure 2-2. Connecting the NETGEAR Model RT210 router to ISDN in North America**

## Connecting to a Hub

Your router can be connected to a hub as illustrated in [Figure 2-3](#), where a router is integrated with the NETGEAR Model EN108 10BASE-T hub.

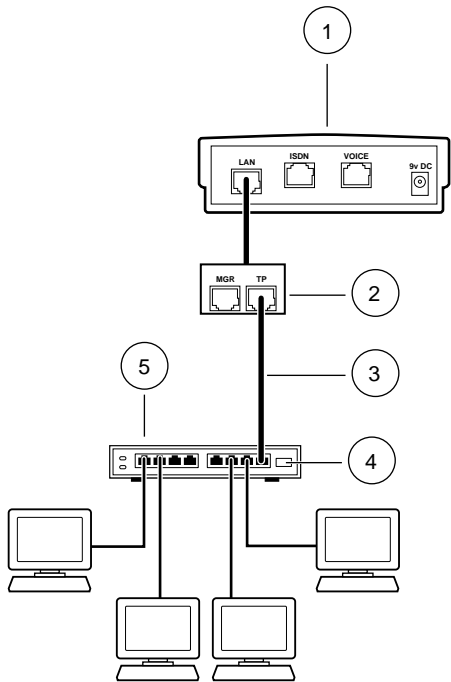

7287

Key:

- 1 Router
- 2 RJ-45 two-way splitter
- 3 10BASE-T Ethernet Cable (round) connected to Uplink port on hub
- 4 Switch on hub set to Uplink (or MDI) position
- 5 Hub

**Figure 2-3. Router connected to a hub**

To connect your router to a hub, follow these steps:

**1. Make sure that your router is disconnected from the AC power.**

You can do this by either disconnecting the AC power adapter from your wall outlet or by disconnecting the AC power adapter from the 9V DC port on your router.

2. Position the switch on the 10BASE-T Ethernet port on your hub to the uplink (or MDI) position.
3. Connect the twisted-pair LAN cable from the 10BASE-T Ethernet uplink port on your hub to the TP port on the RJ-45 two-way splitter.

If your hub has only regular (or MDIX) ports, use an Ethernet crossover cable, which you must supply, to connect a hub port to the LAN port on the router.

4. Reconnect the power to your router.

## Power Connection

Power is indicated by the LED on the top of your router, as illustrated in [Figure 2-4](#). When the power for the router is turned on for the first time, the LED lights red for two to five seconds and then lights a steady green as long as power is on and the router is functioning properly. Your router is now operational.

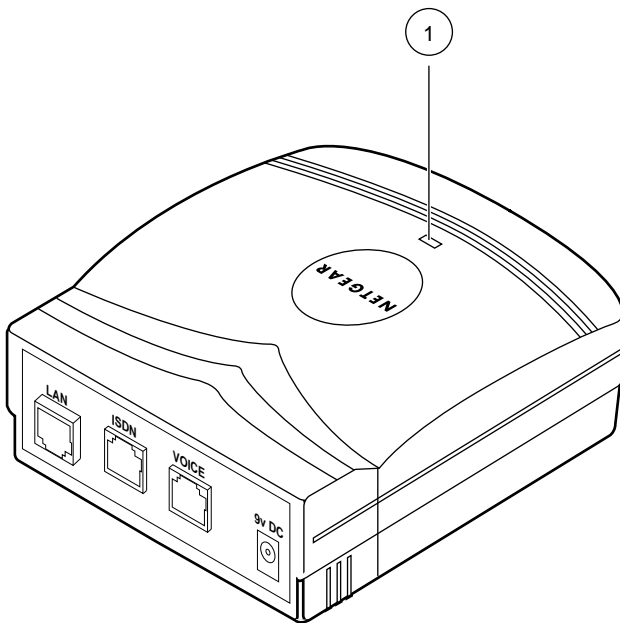

7283

Key:  
1 LED

**Figure 2-4.** NETGEAR ISDN router

[Table 2-1](#) describes the LED activity that shows the status of the router.

**Table 2-1. Router LED**

Color	Activity	Function
Green	Steady	Indicates the router is receiving power and running.
Green	Blinking	Indicates an ISDN call is in progress.
Red	Blinking	Indicates the router is malfunctioning.
Red	Steady	Indicates the router is malfunctioning.
Yellow	Blinking	Indicates the router is loading software. This happens during software upgrade.

## Using the FirstGear ISDN Router Configuration Utility

If you are using a PC, NETGEAR provides FirstGear, an easy-to-use Windows-based utility that leads you through a Quick Setup or an Advanced Setup menu for configuring your router. For FirstGear instructions, refer to *Getting Started Using FirstGear*.

## Connecting Through a Serial Port or a Telnet Connection

If you are using a Macintosh or UNIX-based workstation, using the built-in interface is the only way that you can configure your router. If you are using a PC, you can use either the built-in interface or FirstGear to configure your router.

You can use the built-in interface by connecting through a serial port connection to the Manager/LAN port using a VT100 terminal or a PC-based terminal emulation program. You can also connect across the LAN through a TCP/IP Telnet session.

## Connecting Through a Serial Port

For terminal emulation from a PC, you can use either Microsoft Terminal under Windows 3.1, or HyperTerminal under Windows 95. Be sure to set the program for VT100 emulation, including arrow keys. Serial port parameters are:

- 9600 bps
- 8 data bits
- 1 stop bit
- No parity
- No flow control

After the serial session is opened, refer to [“Using the Built-in Interface Quick Setup”](#) or [“Using the Built-In Interface Basic Setup”](#) in Chapter 3.

## Connecting Through a Telnet Connection

The NETGEAR Model RT210 and Model RT211 ISDN routers are shipped with a default IP address of 1.1.1.1. If the router configuration is cleared, the IP address reverts to the default address.

To make a Telnet call from a TCP/IP workstation, you must do one of the following:

- Set your workstation to a spare IP address on network 1.0.0.0 (netmask 255.0.0.0).
- Add a route to the static routing table of the workstation that indicates that network 1.0.0.0 can be reached via the local LAN port.



**Note:** When you change the IP address of the router while connected through Telnet, you lose the Telnet session. You must then use Telnet to access the new IP address and log in again.

---

After the Telnet connection is made, refer to [“Using the Built-in Interface Quick Setup”](#) or [“Using the Built-In Interface Basic Setup”](#) in Chapter 3





---

# Chapter 3

## Configuring the Router

This chapter contains information about configuring your router through the built-in interface Quick Setup or Basic Setup.

### Configuration Methods

If you are using a PC, you have two options to configure your router, either through FirstGear or through the built-in interface. FirstGear is an easy-to-use Windows-based utility that leads you through a Quick Setup or an Advanced menu for configuring your router. For FirstGear instructions, refer to *Getting Started Using FirstGear*.

If you are using a Macintosh or UNIX-based workstation, using the built-in interface Quick Setup or Basic Setup is the only way that you can configure your router through your computer. However, you can use a PC to configure the router and connect the router to the Macintosh or UNIX-based workstation after the configuration process is complete.

The built-in interface is accessible either through a serial or Telnet connection (refer to [“Connecting Through a Serial Port”](#) or [“Connecting Through a Telnet Connection”](#) on [page 2-13](#)).

The built-in interface Quick Setup is a quick configuration process that is used if you are dialing out, are not receiving incoming calls, and are using Point-to-Point Protocol. In most cases you use PPP, but you can find out from your Internet service provider.

The built-in interface Basic Setup is used if you are dialing out to multiple locations, receiving incoming calls, or using additional features such as CLI or MSN.

## Using the Commands in the Interface

When using the Quick Setup in the built-in interface, you are prompted as you move through the screens. When using the Basic Setup in the built-in interface, you need to know the commands that enable you to move through the screens. [Table 3-1](#) provides the key character commands, [Table 3-2](#) provides a list of the task commands, and [Table 3-3](#) provides the control character commands.

**Table 3-1. Key character commands**

Keys	Action
Arrow	Move from parameter to parameter in any menu.
[Enter]	Move from parameter to parameter in any menu.
[Tab]	Move from parameter to parameter in any menu.
Space bar	Select between fixed values in certain parameters.

**Table 3-2. Task commands**

Command	Action
DEFCON	Default the currently saved configuration. Enter Y to erase the saved configuration, reboot, and load the default configuration.
REBOOT	After being asked to confirm the action, use this command to reboot. Unsaved configuration changes are lost and the system resets. The stored configuration is loaded.
DCONFIG	List the configuration. The screen pauses before listing the configuration. If a record is required of the configuration, the attached terminal should have the capture mode activated. Press the space bar to start listing the configuration. Upon completion, terminate the file capture and press the space bar to return to the menu system.
LCONFIG	Load an existing configuration file into the router. When prompted, send the file to the unit as an ASCII file. When the configuration file has been loaded into memory, the unit automatically reboots itself with the new configuration.
VER	View the current operating version of the software.

**Table 3-3. Control character commands**

<b>Control Character(s)</b>	<b>Action in the menu</b>	<b>Action in the form</b>
[Cntl]+A	Same as in the form.	Toggles VT100/Teletype Terminal Mode.
[Cntl]+B	Move to the previous page.	None.
[Cntl]+C	None	Abort the form. You leave the form and go to the previous menu without saving any changes.
[Cntl]+E	None	Submit the form. The changed parameters are stored in current configuration memory. Most changes take place immediately.
[Cntl]+G	Go to the top-level menu of the path you are in.	Go to the top level menu without saving any field changes.
[Cntl]+H	None	Backspace in the field, deleting characters.
[Cntl]+I	None	Same as pressing the TAB key.
[Cntl]+L	Go to the previous screen.	Leave the form and go to the previous menu without saving any changes.
[Cntl]+M	Typed command line text submitted for processing.	Move the cursor to the next field.
[Cntl]+N	Move to the next page in a multipage form.	None.
[Cntl]+R	Recall the last command entered. The previous 10 commands are stored in a circular buffer.	Recall the last value stored in the field where the cursor is located. Values are recalled until the form is submitted by (<CTRL>+E), after which the new value is recalled.
[Cntl]+U	Delete the command line text.	Delete the field value.
[Cntl]+V	Same as form.	Repaint the screen. Enables the screen to be refreshed if the terminal is used for hot-keying between this and other systems.
[Cntl]+Z	Recall commands in reverse order.	None.

## Using the Built-in Interface Quick Setup

When using the built-in interface Quick Setup, you are prompted to:

- Name your router with your account login name
- Enter your IP address
- Configure your ISDN line

In North America, you need to know your SPID(s), directory number(s), and the type of switch that your telephone company has.

- Enter your account password

To connect to the built-in interface Quick Setup, follow these steps:

1. **Establish a Serial or Telnet connection as described in [“Connecting Through a Serial Port or a Telnet Connection.”](#) on [page 2-12](#).**

2. **Press any key to bring up a screen that prompts for a password.**

3. **Enter PASSWORD.**

PASSWORD must be typed within the brackets on the screen. The router is shipped with this password. You must enter the password in all uppercase letters in order to proceed.

4. **Enter Y when you are asked if you wish to run Quick Setup.**

You are prompted to run Quick Setup only if you have not previously configured the router or if a previous configuration has been cleared.

5. **Follow these steps if you are not prompted, but want to run the Quick Setup program:**



**Caution:** By doing the following, you erase any previously saved configuration.

---

- a. **Enter DEFCON.**
- b. **Enter Y when you are asked if you wish to erase CONFIG and reboot.**
- c. **Press [Enter] after the rebooting procedure runs for about 10 seconds.**

**d. Enter PASSWORD.**

PASSWORD must be typed within the brackets on the screen. You must enter the password in all uppercase letters in order to proceed.

**e. Enter Y when you are asked if you want to run Quick Setup.**

**6. Enter the login name provided by your Internet service provider or system administrator when you are asked for the name of the router.**

**7. Enter the IP address and netmask assigned to your router by your Internet service provider or system administrator.**

You are asked to enter the IP address (n.n.n.n/n) for this router. The number following the slash mark is the netmask. If the netmask was given to you in the form of N.N.N.N, you must convert this to the form /n (refer to [Table 3-4](#)).

**Table 3-4. IP address and netmask format**

---

<b>IP address format</b>	<b>Netmask format</b>
255.0.0.0	/8
255.255.0.0	/16
255.255.255.0	/24
255.255.255.128	/25
255.255.255.192	/26
255.255.255.224	/27
255.255.255.240	/28
255.255.255.248	/29
255.255.255.252	/30
255.255.255.254	/31

---

If your case is not shown, consult your Internet service provider or system administrator. If single host address operation is needed, enter the IP address with a netmask of /0, and select PPP mode at the next prompt. For more information about single host addressing, refer to [“Operating with a Single IP Address,”](#) on [page 3-14](#).

**8. Enter Y when you are asked if you want to use PPP.**

Use PPP unless you are only calling other NETGEAR routers.

**9. Enter the phone number your router is calling when you are asked to enter the remote ISDN number to dial.**

If you are a North American user, precede the number with a 1 if necessary for your dialing system and include the area code. Do not use any spaces or dashes (for example, 18005551212). If the connection is on a 56 KBps line, precede the number with the # symbol.

**10. Enter the account password provided by your Internet service provider or system administrator when you are asked to enter the password/secret/key.**

**11. Enter Y when you are asked whether the line is standard National ISDN, if the switch you are connected to is configured for National ISDN protocol.**

If you are a North American user, your local telephone company must tell you the type of switch you are connecting to and whether the switch is configured for National ISDN or for a custom protocol.

Enter N if the line is not a National ISDN line or if the switch is configured for a custom protocol.

You are given a list of possible switch types to select from. If you choose AT&T point-to-point switch configuration, you are finished at this point. Go to step 15.

**12. Enter the number of the ISDN phone numbers to be supported.**

**13. Enter the one or more ISDN phone numbers that you have been given by your local telephone company.**

It is not necessary to include the area code.

**14. Enter the SPID number for each directory number.**

For each number you were given, you are prompted to enter both the directory number and the SPID.

After entering the last SPID number, you receive a message that the Quick Setup is complete and the router is ready for use. The LED on the router turns red, and then blinks green to show the router is attempting to dial.

**15. Enter SAVE when the router LED returns to a steady green light.**

This saves the configuration.

## Using the Built-In Interface Basic Setup

This section shows you how to:

- Name the router
- Enter the network address
- If in North America, configure the ISDN line
- Connect to another NETGEAR or Bay Nautica Series router
- Connect to a router using PPP
- Verify autocal operation
- Configure a PPP path

To configure your router through the Built-in Interface Basic Setup instead of the Built-in Interface Quick Setup, follow these steps:

1. **Establish a Serial or Telnet connection as described in [“Connecting Through a Serial Port or a Telnet Connection”](#) on [page 2-12](#).**
2. **Press any key to display the screen that prompts for a password.**
3. **Enter PASSWORD in uppercase within the brackets on the screen.**

PASSWORD is the password shipped with the router.

If you have connected to this interface before and assigned a different password, enter the password exactly as you previously typed it. To clear any previous configurations and restore the default condition, follow these steps:

- a. **Enter DEFCON.**
  - b. **Enter Y when you are asked whether you are sure you want to erase CONFIG and reboot.**  
The unit erases any saved configuration, load the defaults, and reboot.
  - c. **Press [Enter] after the rebooting procedure runs for about 10 seconds.**
  - d. **Enter PASSWORD.**
4. **Enter N when you are asked whether you want to run Quick Setup.**

## Naming the Router

To name your router, follow these steps:

1. **Enter CO to display the Configuration Menu.**
2. **Enter SYS to display the Update System Parameters screen.**
3. **Enter the login name of the router.**

The name of the router is provided by your Internet service provider or system administrator. Do not use space characters in the name.

If you want to change your password, follow these steps:

- a. **Tab to the Old Password field and enter the old password.**  
The old password is PASSWORD if this is the first time you are connecting to the built-in basic setup interface.
  - b. **Tab to the New Password field and enter the new password.**
  - c. **Tab to the Retype Password field and enter the new password again.**
4. **Press [Ctrl]+E to apply the changes and return to the Configuration Menu screen.**
  5. **Enter SAVE to save the changes.**

## Entering the Network Address

To specify the network address of your router, follow these steps:

1. **Enter CO PA to display the Configure Paths Menu.**
2. **Enter EDIT LAN01.**
3. **Tab to the IP Addr field and enter the IP address followed by a / character and the number of network bits in the netmask for the unit.**  
Refer to [Table 3-4](#) and the text following for the correct format.
4. **Press [Ctrl]+E to apply the change.**
5. **Enter SAVE to save the changes and return to the Configure Paths Menu.**



**Note:** When you change the IP address of the router while connected through Telnet, you lose the Telnet session. You must then use Telnet to access the new IP address and log in again.

---



## Configuring the ISDN Line

If you are in an area other than North America, skip this section.

For information that assists you in configuring your ISDN line, refer to [Appendix C, “Ordering ISDN Lines.”](#)

To configure your ISDN line, follow these steps:

1. **Enter CO PO to display the Configure Ports Menu.**
2. **Enter EDIT ISDN01 to configure the first B channel.**
3. **Tab to the SPID field and enter the service provider identification number provided by the telephone company.**

This field should be left blank with AT&T Custom Point-to-Point configurations.

4. **Tab to the Local Num field and enter the directory number provided by the telephone company.**

This can be either 7 or 10 digits. Leave the field blank for AT&T Custom Point-to-Point configurations.

5. **Tab to the Switch Type field and press the space bar until you have selected your switch type.**

If your switch is running National ISDN protocol, select National ISDN instead of the switch manufacturer.

6. **Press [Ctrl]+E to apply the changes.**
7. **Enter SAVE to save the changes and return to the Configure Ports menu.**
8. **Enter EDIT ISDN02 to configure the second B channel.**
9. **Repeat steps 3 through 7, entering the service provider identification and directory numbers for the second B channel.**

If you have only one SPID and one directory number, use the same for both B channels.

10. **Turn off the router for 5 seconds and turn it on again.**

This can be done by either disconnecting the AC power adapter from your wall outlet or by disconnecting the AC power adapter from the 9V DC port on your router.

## Connecting to Another NETGEAR or Bay Networks Nautica Router

The Nautica™ Series routers include the Xylogics CLAM™ and MARLIN™ routers. Use the following procedure if you are connecting your unit to another NETGEAR or Nautica Series router. Otherwise, skip to [“Connecting to a Router Using Point-to-Point Protocol”](#) on [page 3-11](#).

To configure an ISDN path between two NETGEAR routers or between a NETGEAR and a Nautica Series router, set up a call between the two units.

To set up a call between the two units, follow these steps:

- 1. Enter STAT ISDN to display the ISDN Port Status menu.**
- 2. Type CALL and the ISDN phone number.**

CALL must be followed by a space and the ISDN phone number of the other router. If the connection is on a 56 KBps line, prefix the number with “#”symbol. An ISDN call is now set up to the remote router, a path with the relevant ISDN number is created, and routing information is exchanged. Any routes created are marked as routes learned by ISDN and are treated as such.

- 3. Press [Enter] to set up the ISDN call that connects the remote router.**
- 4. Leave the call running for three minutes to learn the addresses.**
- 5. Enter CLEAR to cancel the call.**
- 6. Enter SAVE to save the learned path to memory.**
- 7. Repeat steps 1 through 6 for each remote router you wish to connect.**

Your router is now configured and the ISDN connection to these networks is made and broken automatically on demand.

If the ISDN provider enables the Caller Line Identification (CLI or Caller ID) at the answering end, the answering router learns the ISDN number of the calling router when the call is made and automatically adds it to the path it creates. If CLI is not available, the ISDN number must be entered in the path manually.

## Connecting to a Router Using Point-to-Point Protocol

Point-to-Point Protocol (PPP) is a standard means of transporting multiprotocol datagrams over point-to-point links and has been adopted as a method of interoperation between different manufacturers. Although PPP is standards-based, implementation options vary. PPP can include one of the following levels of security:

- Password Authentication Protocol (PAP)
- Challenge Handshake Authentication Protocol (CHAP)

If either PAP or CHAP authentication is to be used, it is necessary to preconfigure the paths. The paths contain the relevant passwords to be used in the authentication process.

For further information, refer to [Chapter 4, “Menus and Commands.”](#)

Before you start, you need to know the following:

- The ISDN Number of the remote router
- The manufacturer and model of the remote router
- If PAP Authentication is to be used:
  - The PAP User ID (System or Login name) assigned by your network provider for calls from your router
  - The PAP Password of your router (Outgoing Password) assigned by your network provider for calls from your router
  - The PAP User ID of the remote router (Path Name) assigned by your network provider for calls to your router
  - The PAP Password of the remote router (Incoming Password) assigned by your network provider for calls to or from your router
- If CHAP Authentication is to be used:
  - The CHAP User ID (System or Login Name) assigned by your network provider for calls from your router
  - The CHAP password (CHAP Secret) assigned by your network provider for calls from your router
  - The CHAP User ID of the remote unit (Path Name) assigned by your network provider for calls to your router

To ensure that the router knows that routes are learned over an ISDN path, you must enter an ISDN number in the configuration path. Any routes learned through this path are displayed with an I after the routing protocol R (RIP) in the routing table display.

To connect to a router using PPP, you must first configure a PPP path.

## Configuring a PPP Path

To configure a PPP path, follow these steps:

1. **Enter CO PA to display the Configure Paths menu.**
2. **Enter ADD to add a PPP path.**
3. **Enter the name of the remote router in the Name field.**

This must match the User ID that is supplied by the remote router if calls are to be made to your router using authentication.

4. **Tab to select the ISDN1 field and enter the ISDN phone number of the remote router.**

If the connection is on a 56 Kbps line, enter the # symbol before the ISDN number.

5. **Tab to select the PPP Prof field and press the space bar until you have selected the appropriate authentication option.**

For further information on authentication and the option that you need, refer to the tables in [Appendix E, “PPP Authentication Profiles.”](#)

- If using PAP authentication, select the PPP OutgoingPW field and enter the password to be used when calling the remote router.
- If using PAP authentication, select the PPP incoming PW field and enter the password to be used by the remote router when calling your router.
- If using CHAP authentication, select the PPP Secret field and enter the password to be used when connecting to the remote router.

6. **Enter the IP address in the IP ADDR&MASK field only if the link is to be numbered.**

The path operates as unnumbered with the IP ADDR&MASK left at its default value (0.0.0.0), and no identifying network addresses are negotiated when the link is set up. Any IP data packets have the LAN01 IP address as their source address. Any other value entered in the field are sent during link establishment to negotiate a numbered link except for a Single Host Address. For more information on a Single Host Address, refer to [“Operating with a Single IP Address”](#) on [page 3-14](#).

7. **Press [Cntl]+E to apply the changes.**
8. **Enter SAVE to save the changes.**
9. **Enter STAT ISDN to display the ISDN Port Status menu.**
10. **Type CALL and the ISDN phone number.**

CALL must be followed by a space and the ISDN phone number of the other router. If the connection is on a 56 Kbps line, prefix the number with “#” symbol. An ISDN call is now set up to the remote router, a path with the relevant ISDN number are created, and routing information is exchanged. Any routes created are marked as routes learned by ISDN and are treated as such.

11. **Press [Enter] to set up the ISDN call that connects the router.**
12. **Leave the call running for three minutes to learn the addresses.**
13. **Enter CLEAR to cancel the call.**
14. **Enter SAVE to save the learned path to memory.**
15. **Repeat this procedure for each remote router you wish to connect.**

Your router is now configured and the ISDN connection is made and broken automatically on demand.

## Verifying Autocall Operation

You can verify autocall operation by communicating through a software application of your choice with the remote devices that you have configured on your network. You can do this by pinging one of the remote routers through the built-in basic interface. For further information about pinging, refer to [“Using the Ping Utility to Troubleshoot a TCP/IP Network,”](#) on [page 5-5](#).

After calls are made automatically and are disconnected when idle, you can make changes to other parameters. A call is considered idle when no real data is being sent across the path for the period set in the Threshold Period parameter on the Configure Paths menu. After calls are made automatically and are disconnected on other remote units, you can then make changes to parameters on remote units.

Other path parameters that may need setting are additional bandwidth and PAP and CHAP security. For information about setting additional bandwidth, refer to [“Obtaining Additional Bandwidth”](#) on [page 3-14](#). For information on PAP and CHAP security, refer to [“Defining Security Levels”](#) on [page 1-8](#).

## Operating with a Single IP Address

Many Internet service providers (ISPs) supply a single 32 bit host address to the user instead of a netmask address. ISPs assign this address to the host PC or the workstation and do not leave an address free for the LAN port of the router. Therefore, there is not a gateway through which the host can send packets for routing to other networks.

To overcome this problem, the PPP path should have the host address entered in the IP ADDR&MASK field of the path with a netmask of /0. The LAN01 path can then be assigned any unused address on the same segment as the host, but should be entered with a netmask of /32. This is what the host should use as the default gateway. The IP address of the router (LAN01) is never advertised across the link. It is used only on the local network for communications between the host and the router.

If the unit is configured through Quick Setup with a netmask of /0, the LAN01 path is automatically assigned a value equal to the 32 bit host address + 1. The incremented LAN01 address is assigned with the assumption that this address might belong to another host allocated by the ISP, but that communication between the two users is not required.

## Caller Line Identification (CLI)

CLI can be used to give access only to those ISDN callers whose numbers have been previously configured.

If Caller Line Identification is enabled on the ISDN line by the service provider, the ISDN number of the calling unit is presented to the router when a call is received. If the CLI parameter on the CONF PORT screen is set to YES, all configured paths are scanned to see whether the calling number matches one in a path. If it does, the call is accepted. If the calling number does not match one in a path, the call is rejected.

## Obtaining Additional Bandwidth

There are two methods of making ISDN calls automatically to obtain extra bandwidth for a path:

- Minimum bandwidth
- Bandwidth on demand

These two options are set in the Configure Paths menu.

When you set the MinBandwidth parameter to a multiple of 64,000 bps, ISDN calls are made as soon as the path is set up and until the bandwidth requirement is met.

The DemandThreshold parameter specifies the percentage of current path usage when an additional demand call must be made. To prevent calls from being made for short bursts of traffic, the percentage must be met for the period specified by ThresholdPd (Threshold Period).

For Bandwidth on Demand, the IdleThreshold parameter specifies the percentage of usage below which a demand call should be closed. The IdleThreshold must be met for the ThresholdPd. Because of the packet splitting feature of the NETGEAR Model RT210 and Model RT211 ISDN routers, there is always a small amount of data sent on the additional channel while data is being sent on the original channel. To allow the path to fall back to only one channel, an IdleThreshold value should be entered at which the channel is classed as unused. The original call is closed only when no real data has been sent or received for the ThresholdPd.

You can configure MaxBandwidth in multiples of 64,000 bps. However, setting MaxBandwidth to 64,000 bps limits the path to only of the two ISDN ports.

If possible, these parameters should be set at one end only to avoid call collisions if both ends of the path try to make calls at the same time.

## **Subaddressing and Multiple Subscriber Numbering (MSN)**

If your NETGEAR Model RT210 ISDN router shares an ISDN line with other ISDN devices, the router must identify where the incoming calls belong. Subaddressing and MSN are the two methods for doing this and must be enabled by your ISDN provider. All ports must be configured with the same values or the ports might answer calls that are not intended for the router.

The subaddress appears as a suffix to an incoming ISDN number. In order for the router to recognize the subaddress, it must be configured in the ISDN PORT form. The subaddress is usually a single digit. Many ISDN providers prefix the subaddress with a zero. Check with your supplier and enter the value in the correct format in the subaddress configuration field.

If the router has no subaddress configured, it answers any incoming subaddressed call. To make a call to a router that has a subaddress configured, use the ISDN number followed by the \* symbol and the subaddress number. Do not include any extra digits that the ISDN service adds to the subaddress.

When an ISDN line has MSN enabled, a range of numbers is assigned to that line. The service provider usually provides ten. A number could be from 1 to 9 digits depending on the service. The number chosen for the router should be entered in the MSN parameter field in the ISDN Port form. If the router does not have MSN configured, it answers any incoming MSN.



---

# Chapter 4

## Menus and Commands

The NETGEAR Model RT210 and Model RT211 ISDN routers have a built-in software management system that allows you to configure and manage your router. This section shows the menu hierarchy and describes the menus and forms.

For information on the commands that move you through the menus and screens, refer to [Table 3-1](#), [Table 3-2](#), and [Table 3-3](#) in [Chapter 3, “Configuring the Router.”](#)

### Using the Menus

The Main Menu is displayed after you have entered a valid password on the password screen. The default password is PASSWORD. You have three tries to enter the password correctly. If you do not succeed in three tries, you are disconnected from the manager port.

After initial logon, the default password can be changed from the Update System Parameters form (refer to [“Using the Update System Parameters Form”](#) on [page 4-5](#)).

The Main Menu displays a list of menus that you use to configure and manage your router.

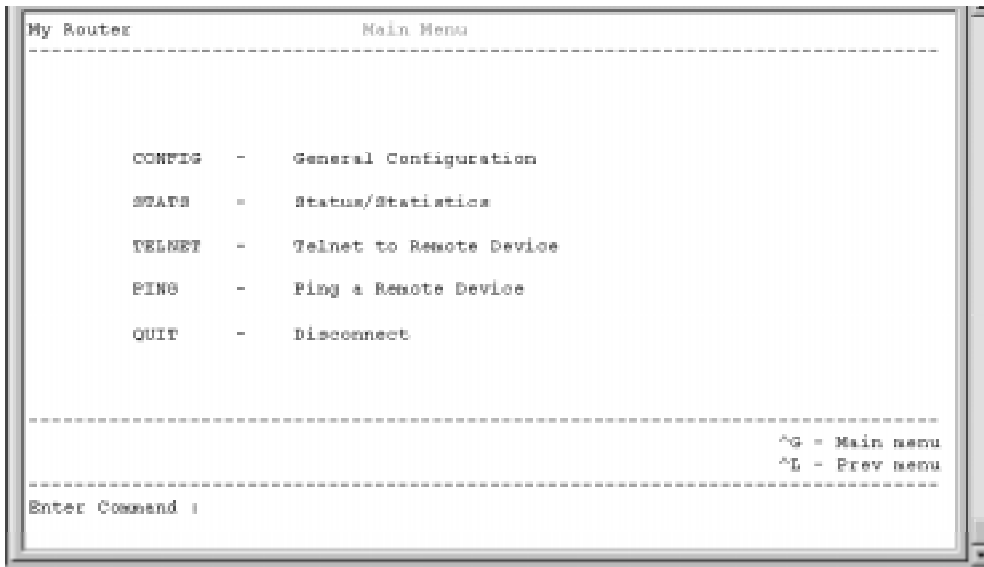
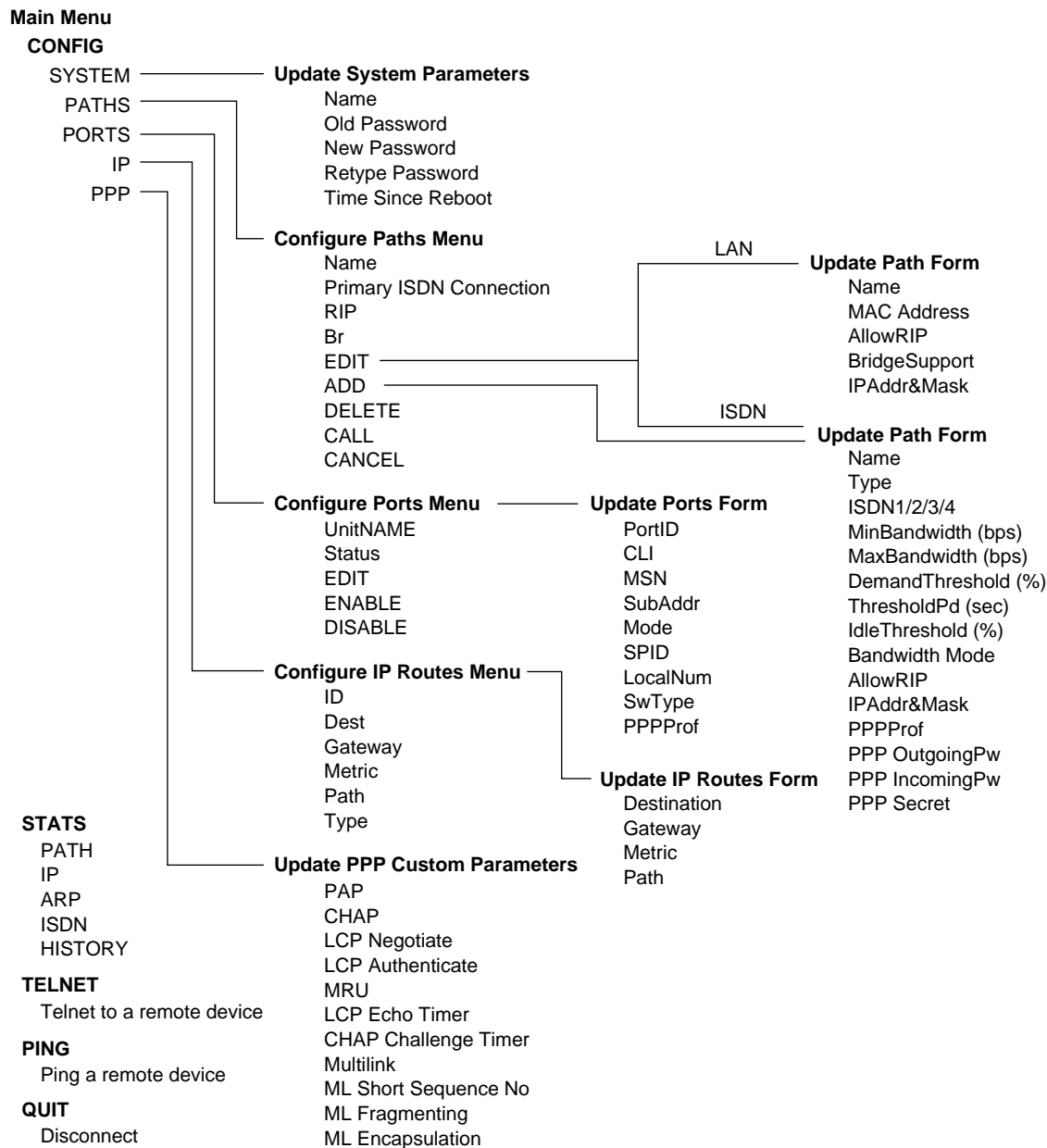

**Figure 4-1. Main Menu**

As illustrated in [Figure 4-1](#), the Main Menu provides the following commands:

- **CONFIG**  
CONFIG provides access to the configuration facilities within the management system.
- **STATS**  
STATS lets you view the status and statistical information maintained by the unit.
- **TELNET**  
TELNET remotely connects to other units by Telnet.
- **PING**  
PING requests an echo packet from a target device.
- **QUIT**  
QUIT will close down the current management session. If you are connected to a remote device, the network connection is closed and control passes back to the original unit.

Figure 4-2 illustrates the built-in interface menu hierarchy.



7431

Figure 4-2. Built-in interface menu hierarchy

## Using the CONFIG Command

The CONFIG command allows you to set general configuration parameters. When you type this command in the Main Menu, the Configuration Menu is displayed.

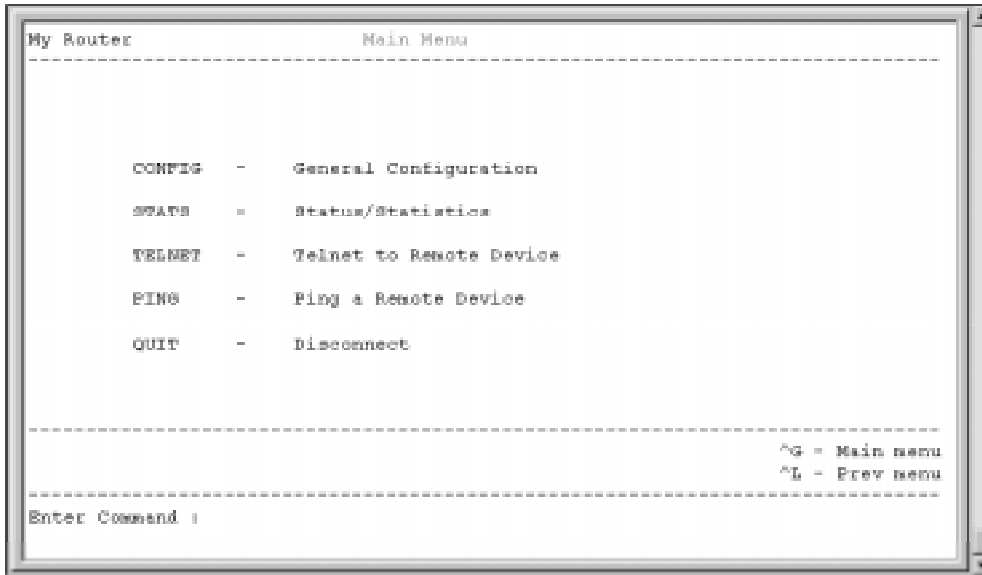

**Figure 4-3. Configuration Menu**

As illustrated in [Figure 4-3](#), the Configuration Menu lists the following commands:

- **SYSTEM**  
This command selects the name of the router, manager password, and displays time since reboot.
- **PATHS**  
This command displays the currently configured paths to other networks and optionally allows their configuration.
- **PORTS**  
This command lets you configure all ports.

- IP  
This command lets you configure the IP routing table.
- PPP  
This command lets you configure the operating mode of the custom point-to-point protocol connection.

## Using the Update System Parameters Form

The Update System Parameters Form provides a list of router parameters that let you name the router, change your password, and display the amount of time since the router was last rebooted.

Following are the menu command options and functions provided by the Update System Parameters Form:

- Name  
This is an alphanumeric name given to the router. Because this name is used during authentication or login with a remote router, the name should be different from any other routers that you are likely to connect together.  
Spaces cannot be used as characters.  
Default: NoConfig
- Old Password  
When changing the password, you must first enter the current password. The current password is not printed when typed. An indication that the password is invalid will be given only when the form is submitted.  
Default: PASSWORD
- New Password and Retype Password  
The new password is entered and re-entered (for confirmation). The new password takes effect immediately. This password is for access to the configuration manager and is not used in call authentication.
- Time Since Reboot  
This is the time in hours:minutes:seconds since the unit was last rebooted.

## Using the Configure Paths Menu

Through several menus and forms, the path management screens assist you in connecting through ISDN, setting up protocols, configuring paths, and calling other devices.

Following are the menu command options and functions provided by the Configure Paths Menu:



**Caution:** By pressing [Cntl]+E, Path parameter edits take effect immediately. You should either make sure paths to be edited are not being used or be aware that data might be discarded when a port is reset. Sometimes routing information might be lost or reset when a form is submitted.

---

- **Name**  
The name of the path, either a LAN port or the name of the remote unit.
- **Primary ISDN Connection**  
If this entry refers to a remote ISDN connected unit, the primary ISDN number called is displayed.
- **RIP**  
The routing information protocol, if any, that is enabled for this path.
- **Br**  
Whether bridging is enabled for this path. It is permanently enabled on LAN01 path.
- **ADD**  
Type ADD to manually configure a path.
- **DELETE**  
Optionally highlight the required path and type DELETE or type DELETE [path name] to remove a path. It is not possible to delete a path that is established. Make sure that all calls are disconnected before deleting a path.
- **EDIT**  
Highlight the required path and type EDIT or type EDIT [path name] to change a path configuration.

- **CALL**

Highlight the required path and type **CALL** or type **CALL [path name]** to establish the path. You can also make switched circuit calls by typing **CALL [circuit/telephone number]** from anywhere except this menu.

- **CANCEL**

Optionally highlight the required path and type **CANCEL** or type **CANCEL [path name]** to cancel an established path.

## **Using the Update Path Form**

The Update Path enables you to add, view, and change the configured paths, assign and enter protocol addresses, and gain additional bandwidth.

The Update Path consists of two forms, both called the Update Path Form, but consisting of two different sets of menu commands, depending on whether you want to edit or add a LAN or an ISDN path.

If you type **EDIT** when the LAN Path is highlighted in the Configure Paths Menu, the Update Path Form for a LAN path is displayed.

The Update Path form for a LAN path gives you the following menu command options and functions:

- **Name**

Default: LAN01

Display item only. This is a system-assigned name.

- **MAC Address**

Display item only. This is the Ethernet MAC address for this interface.

- **AllowRIP**

Enables IP RIP (Routing Information Protocol) in RIP1, RIP1 Compatibility, or RIP2 mode. Disables RIP if set to NONE. The RIP1 Compatibility mode is a subset of RIP2 that also supports and advertises networks with variable-length netmasks.

Default: None

- IPAddr&Mask

Allows entry of the IP address and number of subnet mask bits for this interface. If a subnet mask is not specified, the unit adds the default mask for the class of address configured. This address should be part of the inter-router network addressing scheme.

Default: 1.1.1.1/8

If you type ADD in the Configure Paths Menu or type EDIT when any path except the LAN Path is highlighted, the Update Path Form for an ISDN path is displayed.

The menu command options and functions that are displayed enable you to set up a PP path are:



**Note:** If PAP or CHAP security is to be used, the path must be configured before a PPP connection is attempted or the password/secret cannot be matched with that of the calling device.

---

- Name

This is a user-defined name. If calls are to be received from this path and PAP or CHAP security is enabled, this name must be configured to that of the remote device name. If PAP or CHAP security is not used on this path, the path can be automatically created on detection of the start of the PPP. It is given the name of the port over which PPP is established.

Default: None

- Type

This field is for information only. The value is PPPRouter.

- ISDN1/2/3/4

The ISDN number(s) to dial to connect to the remote unit. If calls are to be received from this path and CLI is enabled, these numbers are compared with the calling number to determine whether the call is accepted.

Default: No default



- MinBandwidth (bps)

The minimum bandwidth that should be allocated to this path. A value of 0 initially uses the single channel capacity. Other values may cause the unit to make additional switched calls until the requirement is met for this path. It is advisable to use multiples of 64,000 bps for ISDN connections.

Default: 0

- MaxBandwidth (bps)

The maximum bandwidth that can be used by this path. A value of 0 defines no upper limit. A value of 64,000 prevents the use of both channels for this path.

Default: 0

- DemandThreshold (%)

The percentage utilization of the path at which an additional call should be made. The DEMAND THRESHOLD is disabled if given a value of 0.

- ThresholdPd (sec)

This is the time-out period after which an idle switched call is automatically disconnected.

Default: 10

- IdleThreshold(%)

The percentage utilization below which a switched call is determined to be idle.

Default: 0

- Bandwidth Mode

Permanent or OnDemand

Default: OnDemand

- AllowRIP

Enables IP RIP (Routing Information Protocol) in RIP1, RIP1 Compatibility, or RIP2 mode. Disables RIP if set to NONE. RIP1 Compatibility mode is a subset of RIP2 that also supports and advertises networks with variable-length netmasks.

Default: None

- IPAddr&Mask

Allows entry of the IP address and number of netmask bits for this interface for numbered links. If a netmask is not specified, the unit adds the default mask for the class of address configured. This address should be part of the inter-router network addressing scheme.

Default: 0.0.0.0

- PPPProf

This profile determines the operating mode of PPP for this path. Selecting CUSTOM displays the Configuration PPP Form that enables you to set up a custom profile. For information about various options when setting up a custom profile, [refer to Table E-1 in Appendix E, “PPP Authentication Profiles.”](#)

Default: Custom

- PPP OutgoingPw

This is the password sent to be authenticated by the other unit in PAP connections. When entered, the password is displayed as a series of asterisks.

Default: No password

- PPP IncomingPw

This is the password matched to the received password to authenticate the other unit in PAP connections. When entered, the password be displayed as a series of asterisks.

Default: No password

- PPP Secret

This is the secret used to authenticate CHAP connections. When entered, the password is displayed as a series of asterisks.

Default: No secret

## Using the Configure Ports Menu

The port configuration screens assist you in configuring and updating the ports.

Following are the menu command options and functions provided by the Configure Ports Menu:

- UnitNAME  
This is a system-assigned number and can be either LAN or ISDN depending on the physical port type.
- Status  
This column displays whether the port is enabled or disabled.
- EDIT  
Optionally highlight the port or type EDIT [port name] to change the parameters.
- ENABLE  
Type ENABLE [port name] to reactivate a disabled port.
- DISABLE  
Type DISABLE [port name] to deactivate a port.

## Using the Update Ports Form

If any of the ISDN port parameters need to be altered, it is necessary to make the same change to both available ISDN ports on the unit. Not changing both available ISDN ports on the unit can interfere with normal operation.

Following are the menu command options and functions provided by the Update ISDN Ports Form:

- PortID  
This is a system-assigned name and cannot be changed.
- CLI  
When Caller Line Identifier checking is enabled, only calls from ISDN numbers defined in existing paths are accepted.  
Default: NO

- MSN

If Multiple Subscriber Numbering is in use, the number assigned to this unit must be entered here.

Default: None

- SubAddr

If Subaddressing is in use, the subaddress number assigned to this unit must be entered here.

Default: None

- Mode

The port can be configured for Incoming, Outgoing, or Bothway for switched ISDN calls, or disabled completely. If a leased line ISDN (Type 4) connection is to be used, select LeasedPP (for PPP Paths). Either of these options are automatically attach the port to the appropriate ISDN channel (ISDN01 = B1 and ISDN02 = B2) on unit reset, without the need for a call being placed. Be careful when disabling incoming or outgoing calls to make sure that this unit is not need to receive or initiate a call.

Default: Bothway

- SPID

For operation in North America, the Service Profile Identifier assigned by the telephone company should be entered here. With certain switches, this parameter does not need to be set. For further information, refer to [Appendix C, "Ordering ISDN Lines."](#) This field has no effect for units fitted with Euro ISDN software.

Default: None

- LocalNum

For operation in North America, the local directory number assigned by the telephone company should be entered here. With certain switches, this parameter does not need to be set. For further information, refer to [Appendix C, "Ordering ISDN Lines."](#) This field has no effect for units fitted with Euro ISDN software.

Default: None

- SwType

For operation in North America, if ISDN interface module(s) with North American ISDN support are fitted to the router, select the switch type used at the central office of the telephone company by pressing the space bar. For further information, refer to [Appendix C, "Ordering ISDN Lines."](#) This field has no effect for units fitted with EuroISDN software.

Default: Nat.ISDN2

- PPPProf

This profile determines the operating mode of PPP for incoming connections on this port and must match the profile that is configured on the appropriate path. The various options are listed in [Table E-1](#) in [Appendix E, “PPP Authentication Profiles](#). CUSTOM profile is user-defined in the CONF PPP form.

Default: Custom

## Using the Configure IP Routes Menu

You can manage your IP routes and create permanent routes by using the IP Routes Menu and Update IP Routes Form.

You can create permanent routes by adding or editing an entry. Enter the Destination, Gateway, and Metric in their normal format, and select the Path from a list of configured paths by pressing the space bar. Other routes are learned dynamically through the use of a routing protocol, for example, RIP. The system automatically adds a path-based route once an address is configured on a path.

Following are the menu command options and functions provided by Configure IP Routes Menu:

- ID

This is a system-assigned number.

- Dest

The destination network or host IP address and subnet bits.

- Gateway

The IP address of another network device to which data should be sent for onward transmission. This address is sometimes known as the next hop device and is not necessary for a non-LAN path.

- Metric

The value that the routing protocol uses to cost the path.

- Path

The path over which the network or host can be reached.

- Type

Path types can be Static, Path-based, or RIP. Path-based or RIP path types can be learned through ISDN.

## Using the Update IP Routes Form

You can Update IP Routes by using the IP Routes form.

Following are the menu command options and functions provided by the Update IP Routes form:

- Destination  
The destination network or host IP address and subnet bits.
- Gateway  
The IP address of another network device to which data should be sent for onward transmission. This address is sometimes known as the next hop device and is not necessary for a non-LAN path.
- Metric  
The value that the routing protocol uses to cost the path.
- Path  
The path over which the network or host can be reached.

## Using the Update PPP Custom Parameters Menu

You can set and update PPP custom parameters by using the Update PPP Custom Parameters menu. For further information on PPP custom parameters, refer to [Table E-4](#) in [Appendix E, “PPP Authentication Profiles.”](#)

Following are the command options and functions provided by the Update PPP Custom Parameters menu:

- PAP  
Enables or disables PAP (Password Authentication Protocol) checking.  
Default: NO
- CHAP  
Enables or disables CHAP (Challenge Handshake Authentication Protocol) checking.  
Default: NO

- LCP Negotiate  
Determines whether the PPP LCP (Link Control Protocol) can negotiate the supported options with the remote system.  
Default: NO
- LCP Authenticate  
Determines whether a remote unit is required to send a PAP authentication User Id and Password if PAP is selected, or if CHAP authentication is selected, a CHAP Challenge is sent to the remote unit. If both PAP and CHAP are selected, the unit negotiates with the remote unit which one is to be used. Authentication of other units also requires that LCP Negotiate is enabled.  
Default: NO
- MRU  
The Maximum Receive Unit is the size in bytes of the largest packet that can be sent or received. This value should not be altered unless required for compatibility with the remote device.  
Default: 1600
- LCP Echo Timer  
This is the time-out in seconds in which an LCP Echo should be issued to determine whether the remote device is responding.  
Default: 30
- CHAP Challenge Timer  
The time in seconds after which a CHAP challenge can be issued on active PPP connections.  
Default: 60
- Multilink  
Enables the aggregation of multiple channels.  
Default: NO
- ML Short Sequence No  
Default: NO
- ML Fragmenting  
Default: NO

- ML Encapsulation  
Enables a variation of Multilink for implementation for particular vendors.  
Default: NO

## Using the STATS Command

By using the STATS command, you can view the status and statistics of paths, the IP routes, the ISDN ports call status and the history of calls.

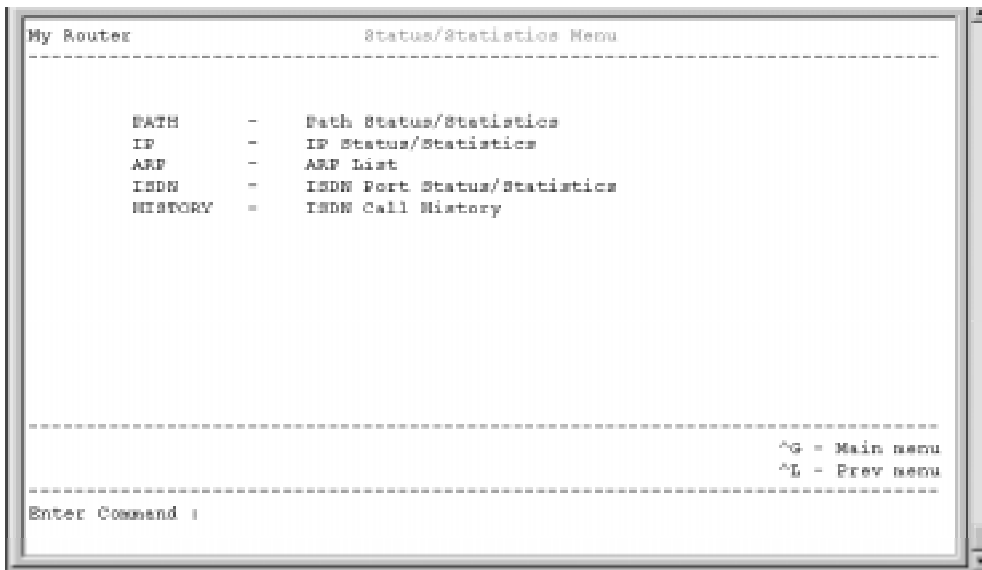

Figure 4-4. Status/Statistics Menu

## Viewing the Status/Statistics Menu

As illustrated in [Figure 4-4](#), the following viewing options are provided by the Status/Statistics Menu:

- PATH  
Displays the statistics of all active paths.
- IP  
Displays the statistics of the IP routes.



- **ARP**  
Displays the address resolution table.
- **ISDN**  
Displays the ISDN ports call status.
- **HISTORY**  
Displays the historical dialed call data.

### **Viewing Path Status**

Following are the viewing options provided by the Path Status Menu:

- **Path**  
The name of the path as defined in the configuration.
- **Port**  
The system port or ports that the path is currently using.
- **TeleNo**  
If this path is established through a dialed connection, the number is displayed, if it is known. The call direction is indicated as either (O)utgoing or (I)ncoming.
- **Tx/Rx %**  
The transmit and receive utilization is shown as a percentage of available port bandwidth.
- **TxLZ**  
The transmit and receive compression ratio as a total per path.
- **Bandwidth**  
The bandwidth for each port connection of the path in bits per second.
- **Total**  
If more than one connection is established to a path, the sum of the bandwidths is displayed in bits per second.

## **Viewing IP Status**

Following are the viewing options provided by the IP Status Menu:

- ID  
This is a number assigned by the system.
- Dest  
For each IP connection, the destination IP address is shown.
- Gateway  
The gateway through which the destination can be reached.
- MAC  
If the destination host or gateway is on the local network, the MAC address of the port is displayed.
- Packets  
The number of packets transferred for this route.
- Byte  
The number of bytes transferred for this route.
- Path  
The path over which the route is targeted.

## **Viewing the ARP List**

The ARP list contains known IP address to Ethernet MAC address resolutions for the local LAN. If a device is assigned a new IP address or an existing station has the Ethernet card replaced, the entry needs to be deleted and relearned.

Following are the viewing options provided by the ARP List Menu:

- ID  
This is a number assigned by the system.
- Dest  
The destination host IP address.

- **MAC**

The physical MAC address of the device. If this entry is blank, the device is on a remote network. If the entry is “aaaaaaaaaa,” an ARP request has been sent but no response has yet been received. A broadcast on the local LAN is indicated by the entry “ffffffffff”.

### **Viewing ISDN Port Status**

Following are the viewing options provided by the ISDN Port Status Menu:

- **PORT**

The ISDN port system name.

- **STATUS**

Either Answered, Called, or Calling.

- **NUMBER**

The number called or the number calling if CLI is operational for an incoming call.

- **TIME**

Call duration in hh:mm:ss format.

- **B CHANNEL**

The B channel of the ISDN line that the call is using.

- **ERROR CODE**

Error codes sent by the ISDN network.

- **MODE**

Synch and the speed of the ISDN call.

### **Viewing ISDN Call History**

Following are the viewing options provided by the ISDN Call History Menu:

- **NUMBER**

The ISDN number for this entry.

- **TYPE**

The type of call, either manual, incoming, or automatic. This includes bandwidth on demand calls.

- **TOTAL**  
The total duration of all calls for this entry.
- **MIN**  
The shortest duration call for this entry.
- **MAX**  
The longest duration call for this entry.
- **NUM-CALLS**  
The total number of calls for this entry.

## Using the TELNET Command

You can use the TELNET command from any menu; however, it does not work if you are in a form. The format is TELNET (IP address). The IP address that you type is the full network address of the target device. If the target device is another NETGEAR or Bay Nautica Series router, a remote management session is opened and the initial password prompt screen is displayed.

You can disconnect Telnet sessions by exiting the target device and allowing the connection to clear back to the local router. If you are in a remote management session, type QUIT on the command line to exit the remote session and return control to the local management session. Press [Cntrl]+D to abort the connection.

## Using the PING Command

You can use the PING command to request the echo packets from remote devices for troubleshooting purposes. From any menu that has a command line, use the following format to run the Ping utility:

PING-<option1> <value> [-option2> <value>...] <target IP address>

The options are shown below with the default values in brackets [ ]:

- **-I**  
Time to Live (range 1 to 255), the maximum number of hops. [253]
- **-L**  
Length of the echo packet request. [64 bytes]

- -N  
Number of times to send the echo request packet. [4]
- -T  
Transmit packets continuously. Halt with space bar.
- -W  
Time to wait for a response (range 1 to 3276). [5 seconds]

If the command is used without any options, the target IP address is pinged five times and the results displayed on the screen.

## **Using the QUIT Command**

You can use the QUIT command to close down the current management session. If you are connected to a remote device, the network connection is closed and control passes back to the original unit.



---

# Chapter 5

## Troubleshooting

This chapter provides a description of the command line utilities and a guide to troubleshooting the router.

### Using the Trace Window to Display System Messages

The Trace Window displays messages that show how the internal processes of the unit are performing. Because of the number of complex problems it can diagnose, as more product features are added or enhanced, the Trace Window may contain much more information than you require. The messages displayed by the system vary based on software revisions.

You can access the Trace Window from any menu of the built-in interface by typing TW. To exit the window, press the space bar.

To assist in problem diagnosis, you may find it helpful to save the output of the Trace Window for later review. You should save the output in a file on an attached terminal.

The Trace Window messages are added to the end of a queue that is downloaded whenever the Trace Window is accessed. Appending the messages is not allowed to interfere with normal data transfer; therefore, some messages might not be displayed. By checking the sequence of the messages, you can verify that all messages are displayed.

The following list describes the messages displayed on the screen:

- The record numbers are displayed in the first column and are shown in sequential order. If the numbers are missing, the missing records have been lost because the unit was too busy.
- The second column shows the time stamp, formatted in milliseconds.
- The process that is displaying the message is shown in the third column.
- The diagnostic message is displayed in the last column.

The Trace Window cannot be accessed by more than one “manager” (built-in interface) at a time. An example of multiple accessing is connecting at the same time by a serial connection and by Telnet, or connecting at the same time with two Telnet calls. When you disconnect from the built-in interface, make sure that the Window is not active, especially when you have a remotely accessed Trace Window. Your router tries to forward the packets to the unit that originally accessed the Trace Window.

## Understanding the ISDN Clearing Codes

The ISDN call clearing codes that are returned by the network are listed in [Table 5-1](#). These codes vary depending on your service provider.

**Table 5-1. ISDN clearing codes**

Reason	Description
0	Undefined
1	Unallocated (Unassigned number)
2	No route specified transit network
3	No route to destination
4	Channel unacceptable
6	Channel unacceptable
7	Call awarded and being delivered in an established channel
16	Normal call clearing
17	User busy
18	No user responding
19	No answer from user (user alerted)
21	Call rejected
22	Number changed
26	Nonselected user clearing
27	Destination out of order
28	Invalid number format
29	Facility rejected
30	Response to status enquiry
31	Normal, unspecified
34	No circuit, channel not available



**Table 5-1. ISDN clearing codes (continued)**

Reason	Description
38	Network out of order
41	Temporary failure
42	Switching equipment congestion
43	Access information discarded
47	Resources unavailable (unspecified)
50	Requested facility not subscribed to
63	Service or option not available
84	Call identity in use
88	Incompatible destination
90	Destination address incomplete
102	Recovery on timer expiry
127	Internetworking unspecified

For a list of the internal ISDN call clearing codes generated by the BRI terminal adapter, refer to [Table 5-2](#).

**Table 5-2. ISDN internal clearing codes**

Reason	Description
128 - 143	Call control timer expiry
145	Data link failure
146	TEI or SPID (USA) negotiation failure
162	Network access not connected
177	Call clearing because of restart procedure

## Troubleshooting Your ISDN Line

Correct provisioning of your ISDN line is important. Because there are many different service packages offered in North America, which all have different parameters set in the central office switch, you might experience malfunctions in your ISDN line. If you suspect that your line is not working properly, you can verify its operation by making a loopback test. The loopback test calls out on one B channel and back in on the other B channel.

To make a loopback test, follow these steps:

**1. Type SAVE to save your current configuration.**

When the router connects back to itself in the loopback test, a path with the name of the router is created. After testing, discard this path.

**2. Type STAT ISDN to connect to the ISDN Port Status screen.**

ISDN01 should be highlighted, and both ports must be idle.

**3. Type CALL to place a call.**

CALL should be followed by a space and the number of the ISDN line assigned to the router.

If you have given a different local number to each B channel, use the one you configured under ISDN02. A busy signal, clearing code 17, is received if you are using the number configured under ISDN01.

If there are no problems, the ISDN Port Status screen shows both the outgoing and incoming calls made from and to the unit. If there is a problem, the error code sent by the network or generated internally is displayed on the ISDN01 status line.

For additional information on clearing codes, refer to [Table 5-1](#) and [Table 5-2](#).

The most common ISDN problems are:

- Code 50

The line has not been provisioned correctly.

- Code 146

The local directory number or SPID has been set incorrectly. Check your line configuration with the telephone company and request the local directory number and SPID that you should use.

**4. Type REBOOT to reboot the router and restore the saved configuration.**

## Using the Ping Utility to Troubleshoot a TCP/IP Network

Most TCP/IP terminal devices and routers contain a Ping utility that sends an echo request packet to the designated device. The device then responds with an echo reply.

By using the Ping utility in the built-in interface and in your PC or workstation, you can easily troubleshoot a TCP/IP network.

For further information on the PING utility, refer to [“Using the PING Command”](#) on [page 4-20](#).

## Testing the LAN Path to Your Router

To verify that the LAN path to your router is set up correctly, from the Windows (95 or 3.1) Run menu, type PING followed by the IP address of the router and press the Enter key.

You should see a message like this:

```
Pinging <IP address> with 32 bytes of data
```

If the path is working, you see:

```
Reply from < IP address >: bytes=32 time=NN ms TTL=xxx
```

If the path is not working, you see:

```
Request timed out
```

If the path is not functioning correctly, you might have one of the following problems:

- Wrong physical connections

To make sure that all physical connections are correct, do the following:

- a. Make sure that the Link LED on the Ethernet card in your PC is lit.**
- b. If you are using a hub, make sure that the Link LED on the hub is on for the port connected to your router and for the port connected to your PC.**

Make sure your router is connected to the Uplink (or MDI) port on the hub and any selection switch is set for Uplink (or MDI), if you are using a hub with a straight-through cable.

You need a crossover cable to connect to a regular (or MDIX) hub port.

- Wrong network configuration

To make sure that your network is configured correctly, do the following:

- a. Make sure that the Ethernet card driver software on your PC and the TCP/IP software are both installed and configured.**
- b. Make sure that you have entered the correct value for your router IP address.**

## Testing the Path from Your Router to a Remote Device

To verify that the path from your router to a remote device is set up correctly, use the Ping utility in the built-in interface.

From any menu that has a command line, type PING followed by the IP address of the remote router you are calling. If the path is working, the LED on the router begins to blink and a message similar to the following is displayed:

```
Pinging
# of tries = 5, failures = X :time = Y ms
round-trip average (ms) = Z ms
```

The first few pings might fail while the router is establishing the connection.

If the path is not working, a message like the following is displayed:

```
Pinging
# of tries = 1, failures = 1: ping failed : Timeout
# of tries = 2, failures = 2: ping failed : Timeout
# of tries = 3, failures = 3: ping failed : Timeout
# of tries = 4, failures = 4: ping failed : Timeout
# of tries = 5, failures = 5: ping failed : Timeout
```

If the path is not working, you might have one of the following problems:

- Physical connection

To make sure that the physical connections are correct:

- a. Check that the ISDN port on your router is connected to your NT1 (for RT210) or to the ISDN wall outlet (for RT211).**
- b. If using the RT210, make sure that any LEDs on your NT1 indicate a normal working line connection.**

- Line configuration

To make sure that your line configuration is correct:

- a. Check to see whether the LED on the router remains steady or only blinks once and then remains steady for several seconds. A steady LED or an LED that blinks once and then remains steady indicates improper line configuration.**
- b. Check the values you have entered for Switch Type, Directory Number, and SPIDs.**
- c. If you are using the RT210, make sure that the power for the NT1 is turned on before the router.**

- Call Profile

To make sure your call profile is correct:

- a. Check the LED on the router. If the LED blinks for less than 10 seconds and then lights solid, it indicates that the line was dropped or refused by the remote router.**
- b. Check the values you have entered for Router Name, PPP Profile, and Outgoing Password.**

- Network Configuration

To make sure the network is configured correctly:

- a. Check to see whether the LED blinks.**  
If the LED does not blink, you might have a bad network configuration.
- b. Check to see that the TCP/IP setup on your PC is correct.**  
The TCP/IP setup must have the IP address of your router set as the gateway.
- c. Check to see that the Configure IP Routes Menu of the built-in interface has a static route to the remote router.**

## Testing the Full Path from Your PC to a Remote Device

After verifying that the LAN path and the remote path are set up correctly, test the full path from your PC to a remote device. From the Windows Run menu, type PING -n 10 followed by the IP address of the remote device you are calling.

If the path is functioning correctly, the LED on the router blinks and a few timeouts followed by replies are displayed on the screen. If the path is not functioning correctly, only timeouts are displayed.

If the path is not functioning correctly, check the following:

- a. **Check to see that the IP address of the router is listed as a gateway in the TCP/IP setup on the PC.**
- b. **Check to see that the network address of your PC (the portion of the IP address specified by the netmask) is different from the network address of the remote router.**

## Testing the Voice Port

To test the voice port, lift the telephone handset when there are no calls in progress. The router LED should begin blinking and you should hear a dial tone.

If there is no dial tone, the line might be configured incorrectly. Check with your telephone company that your line is configured for both data and voice.

---

# Appendix A

## Technical Specifications

This appendix provides technical specifications for the NETGEAR Model RT210 and Model RT211 ISDN routers.

### General Specifications

#### Network Protocol and Standards Compatibility

WAN Protocols: PPP, Multilink PPP

Routing Protocols: TCP/IP, IP RIP-1

ISDN Standard: Bellcore National ISDN-1 (USA)  
AT&T 5ESS  
Northern Telecom DMS-100 (USA)  
EURO ISDN NET-3 (Europe)  
Japan NTT INS-Net64 (Japan)

#### Security

PAP, CHAP, Caller ID

#### Data Compression

Lempel-ZIV (STAC)

#### Power Adapter

RT210: 90 - 110V, 50/60 Hz or  
200 - 240V, 50/60 Hz

RT211: 115 - 125V, 60 Hz

9 V DC @600mA output, 15W maximum

9 V DC @1A output, 15W maximum

### Physical Specifications

Dimensions: 131 x 138 x 39 mm  
(5.1 x 5.4" x 1.5 in.)

Weight: 0.3 kg (0.7 lb.)

### Environmental Specifications

Operating temperature: 0° C to 40° C

Operating humidity: 90% maximum relative humidity,  
noncondensing

### Electromagnetic Emissions

CE mark

FCC Part 15 Class B

EN 55 022 (CISPR 22), Class A

VCCI Class 2

### Interface Specifications

LAN: Ethernet(10BASE-T), RJ-45

ISDN:

RT210: S/T interface, RJ-45 (requires external NT1)

RT211: U Interface, RJ-45 (NT1 built-in)

Analog: Voice/fax/modem (up to 28.8 KBps on modem), RJ-11  
2RE (Ring Equivalents), Europe  
4RE, North America and Japan

Manager: RS-232 for setup and configuration (shares LAN connector)



---

# Appendix B

## TCP/IP Routing

This Appendix provides information on the Transmission Control Protocol/Internet Protocol (TCP/IP). TCP/IP is the name of communications protocols used to connect computers and data communications equipment into computer networks.

### IP Addressing

Because TCP/IP networks are used so widely across the world, they need a unique addressing structure to make sure that transmitted data reaches the correct destination. The Internet Protocol uses a 32 bit address structure that is divided into two parts.

The first part of the address identifies the network and the second part identifies the host node or station on the network. To make the addresses easier to understand, the address is usually written in dotted decimal notation. For example, the address: 11000011.00100010.00001100.00000111 is usually written as 195.34.12.7, which is easier to remember and easier to enter into your computer.

There are five classes of IP addresses. The different address classes have different ways of determining the network and host sections of the address, allowing for different numbers of hosts on a network. Each address type begins with a unique bit pattern, which is used by the TCP/IP software to identify the address class. Once the address class has been determined, the software can correctly identify the host section of the address. The three main address classes are illustrated in [Figure B-1](#) and show the network and host sections of the address for each address type.

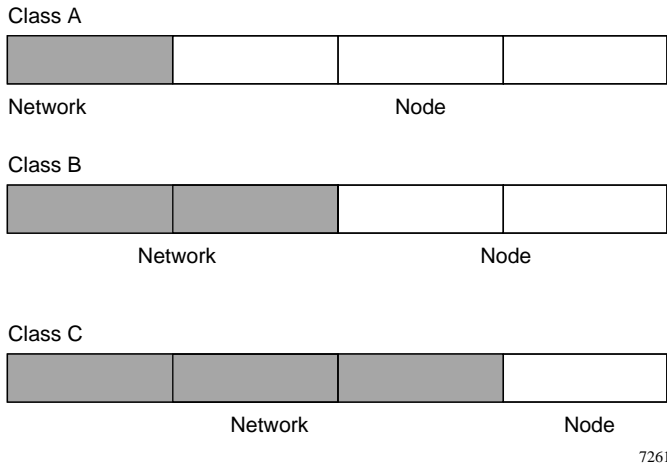

**Figure B-1. Three main address classes**

Class A addresses can have up to 16,777,214 hosts on a single network. They use an 8 bit network number and a 24 bit node number. Class A addresses are in the range 001.xxx.xxx.xxx to 126.xxx.xxx.xxx.

Class B addresses can have up to 65,354 hosts on a network. A class B address uses a 16 bit network number and a 16 bit node number. Class B addresses are in the range 128.001.xxx.xxx to 191.254.xxx.xxx.

Class C addresses can have 254 hosts on a network. Class C addresses use 24 bits for the network address and 8 bits for the node. They are in the range 192.000.001.xxx to 223.255.254.xxx.

Class D addresses are used for multicasts (messages sent to many hosts). Class D addresses are in the range 224.000.000.000 to 239.255.255.255.

Class E addresses are for experimental use for now.

This addressing structure allows IP to uniquely identify each physical network and each node on each physical network.

## Subnet Addressing

By looking at the addressing structures, you can see that even with a Class C address, there are a large number of hosts per network. Such a structure is an inefficient use of addresses if each end of a routed link requires a different network number. It is unlikely that the smaller office LANs would have that many devices. You can resolve this problem by using a technique known as subnet addressing.

Subnet addressing allows us to split one IP network address into smaller multiple physical networks known as subnetworks. Some of the node numbers are used as a subnet number instead. A Class B address gives us 16 bits of node numbers translating to 64,000 nodes. Most organizations do not use 64,000 nodes, so there are free bits that can be reassigned. Subnet addressing makes use of those bits that are free.

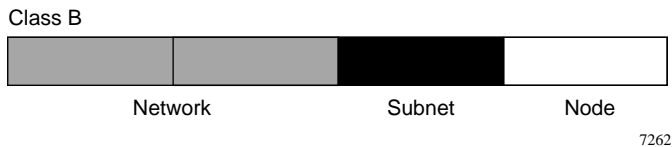

**Figure B-2. Example of Class B address**

A Class B address can be effectively translated into multiple Class C addresses. Example: The IP address of 129.46.0.0 is assigned, limiting node addresses to 255 maximum, allowing 8 extra bits to use as a subnet address. The IP address of 129.46.97.235 would be interpreted as IP address 129.46, subnet number 97, and node number 235. As well as extending the number of addresses available, subnet addressing allows a network manager to construct an address scheme for his or her network by using different subnets for different geographical locations in the network or for different departments in the organization.

## **Address Resolution**

An IP address alone cannot be used to deliver data from one device to another on a LAN. In order for data to be sent from one point in the network to a destination elsewhere, we must convert the IP address.

This IP address must be a unique identifier that identifies the destination device attached to the Ethernet LAN. Each device on an Ethernet network has a unique Ethernet MAC address, which is a 48 bit number assigned to each device usually by the manufacturer. It is possible for some devices to have more than one MAC address if they have multiple connections to Ethernet networks. The technique that converts the IP address to a MAC address so that they match up is known as address resolution.

Unless the router can resolve the network IP address to the Ethernet MAC address, it cannot send the data to the correct device on the LAN. IP uses the Address Resolution Protocol (ARP) to do this.

If a device needs to send data to another station on the network and it does not have its destination MAC address recorded, ARP is used. An ARP request is sent out onto the network, which all stations receive and read. The destination IP Address for the desired station is included as part of the message so that only the station with this IP address responds to the ARP request and all other nodes discard it.

The node whose IP address is included in the ARP request responds with its own MAC address directly to the sender. This provides the transmitting station with the destination MAC address needed for it to send the data. The IP address data and MAC address data for each node is held in a Host Cache or ARP table, so that the next time data needs to be sent, the address can be obtained from the address information in the ARP table.

## **Routing IP Over ISDN**

The NETGEAR Model RT210 and Model RT211 ISDN routers are able to connect to other networks using ISDN just as if the network were attached with a leased line. When data is to be sent to the remote network, the router automatically dials the ISDN number of the router with the router that is advertising the destination IP network address.

The router is able to match the ISDN telephone number to a given IP address by checking the remote router path associated with the destination address and then inspecting the path to determine the ISDN number to be dialed. During initial setup of the router, the user calls any remote units that are to be part of the network. The router automatically learns about those units and creates its routing address table. This process makes it very easy to set up the router and user input errors are less likely.

The NETGEAR Model RT210 and Model RT211 ISDN routers also support a feature called unnumbered links, meaning that you do not have to configure an inter-router network for the path. With unnumbered links, the number of network addresses needed is reduced. You do not need to address each link separately with a consequent reduction in the configuration overhead.

Rather than having all possible destinations preprogrammed, the router is able to support multiple ISDN lines to various destinations that are based on the requirements of the user. Many client/server-based network protocols broadcast idle or hello frames regularly, making them unsuitable for cost-effective bridging or routing across ISDN.

While intelligently routing and spoofing the protocols, the routers make cost-effective routing possible by filtering broadcast and multicast frames. The IP RIP protocol causes routers to send out their routing tables for update every 30 seconds. Although this is of no consequence for leased line connections, it is an important consideration for routers connected over ISDN links. The ISDN links then become active every 30 seconds to transmit this overhead. The router implements an advanced spoofing solution known as piggyback update to overcome this problem. Because changes to the network occur rarely and the routing table updates need not be sent every 30 seconds, the routers transfer the updates only when the link becomes active with real data.

Normally routes learned from routing updates (IP RIP) are aged and removed from the routing table if an update is not received within 180 seconds. However, when routing updates are received only when an ISDN data call is connected, it is likely that there would be insufficient calls made to ensure that routes were not removed after the 180 second time-out had expired. The NETGEAR Model RT210 and Model RT211 ISDN routers make ISDN routes semipermanent so that they can be updated, but so that they do not expire as a result of timeout.

## **Connecting to Other Routers**

When connecting LANs together, you might require each end of the WAN link to be attached to a router from a different manufacturer. Even though the NETGEAR Model RT210 and Model RT211 ISDN routers can operate with routers from other manufacturers, not all the flexibility and functionality are available.

The options of connecting to other routers are:

- NETGEAR to NETGEAR on IP networks

NETGEAR to NETGEAR connections are very efficient. Connecting this way lets you use the advanced ISDN capabilities of the NETGEAR Model RT210 and Model RT211 ISDN routers for routing between networks.

- NETGEAR to third-party router using Point-to-Point Protocol (PPP)

Connecting NETGEAR products to other products using PPP is the simplest but least efficient implementation. PPP does not have a mechanism for arbitrating certain features such as compression. This minimal feature implementation was developed by the IP community and adopted for router interoperability. If using PPP, the NETGEAR router can also use PAP and CHAP for security.

---

# Appendix C

## Ordering ISDN Lines

This appendix provides you with information you need before you order a basic rate ISDN line.

### Ordering an ISDN Line

Before ordering an ISDN line, there are several things you should know about the different kinds of services and the many options that are available. The various kinds of services are described in this appendix. If services that your telephone company offer are not described, you should obtain information from them before ordering your ISDN line.

### Connecting Devices to a Basic Rate ISDN

It is possible to have up to eight devices share a Basic Rate ISDN line with its two 64 KBps B (or bearer) channels and one 16KBps D (or signaling) channel; however, only two devices can make or receive calls over the B channels at any one time. These devices could include ISDN telephones, Group 4 fax machines, Nautica Series bridges or routers, and terminal adapters that allow other types of equipment, such as computers and analog telephones, to be connected to ISDN lines. Depending on the types of the devices you want to attach to your line, you should discuss with your telephone company whether you want the line to be capable of carrying voice traffic, data, or both.

The simplest configuration, known as point-to-point operation, is when only one device is connected to the line. When several devices share a line, the configuration is known as multipoint operation. In multipoint configurations, it is necessary to be able to distinguish between devices, and this is normally done by giving each device a distinct telephone number (also referred to as a directory number).

## **Connecting to ISDN in North America**

National ISDN is a series of standards designed to make it easier to order ISDN services from your telephone company. The National ISDN (NI) standards published by Bellcore are known as NI-1, NI-2, and NI-3. The NI-2 standard, which includes NI-1, is the one that most telephone companies have now implemented. Switches from AT&T, Northern Telecom, and Siemens account for almost all of the switches on the North American Market. These switches all support NI and because of that, most telephone companies offer National ISDN in their networks. However, a significant number of proprietary ISDN line provisions still exist, particularly in AT&T-equipped central offices.

When you order lines from your telephone company, we recommend that you ask for National ISDN.

### **Directory Numbers and SPIDs**

In North America the technique of subaddressing is not used. Instead, a device is identified by the switch in the telephone company's central office by a Service Profile Identifier (SPID). When your telephone company notifies you of the directory number(s) assigned to your line, they provide you with a SPID (Service Profile Identifier). The SPID is a code that must be sent to the switch at the telephone company by your terminal each time it is started. The code is a signal to the switch that says the device is available and lists what the capabilities are. Your equipment is not able to make or receive calls until this SPID negotiation process has taken place. Since the SPID acts like a password, it is very important not to make a mistake when you configure it into your router.

When only one device is attached to a line, known as point-to-point networking, it is not necessary to identify separate devices. During point-to-point networking, the SPID is not used.

SPIDs are normally based on their corresponding seven-digit Directory Numbers. In addition to the DN, there is a prefix and a suffix. The exact format of a SPID varies from telephone company to telephone company, and between switch types. The prefix is frequently the area code or, with AT&T switches, it can be 01. The suffix can be from one to four digits long. Sometimes you must assign the final two digits (called a TID, or Terminal Identifier, which must be in the range 00 to 62). It is important to check with your telephone company to find out what the format of the SPID should be.

For National ISDN, the telephone companies are introducing a scheme that is uniform across the country and the same for all switch types. For a single device on a line, the default SPID is [area code][directory number][01][01]. The second [01] represents the TID. This scheme is expected to be in place nationwide by the end of 1996.



## Switch Types

Even with the development of National ISDN, it is still necessary to know what kind of switch your telephone company uses locally, because National ISDN is still not available everywhere. Even when it is, there are small variations in the way that different manufacturers implement National ISDN.

To correctly order ISDN, you need to know the type of switch that is available in your area. For Basic Rate ISDN, the most common types of switches and the differences between the switch types are:

- AT&T 5ESS

AT&T 5ESS switches allow up to 8 devices to share the two B channels. You can configure lines in one of three ways:

- Custom point-to-point

Custom indicates the use of AT&T's proprietary standard.

- Custom multipoint

- National ISDN

National ISDN is multipoint.

You can order one or more directory numbers per basic rate ISDN line. We recommend that you have only one directory number per line assigned to each router. If you also have other devices attached to the line, they should each have their own directory number.

- Northern Telecom DMS-100 and DMS-250 Series

These Northern Telecom switches almost always have lines configured for National ISDN.

The following restrictions apply to Northern Telecom switches:

- A maximum of two devices can share the two B channels.

- Each of the B channels must have its own directory number.

- Lines from Northern Telecom switches are multipoint.

- Siemens EWSD

Siemens switches can support up to eight devices per basic rate line and lines are always configured for National ISDN. You can order one or more directory numbers per line.

We recommend that you have only one directory number per line assigned to each router. If you have other devices also attached to the line, they should each have their own directory number.

## National ISDN Service Packages

National ISDN service packages determine what combination of features your telephone company provides on your ISDN line.

A package typically consists of the following:

- The combination of voice and data capabilities required on the B channels

When used with NETGEAR or other Bay products, both B channels should be provisioned so that they can carry data. Some phone companies insist that at least one of the B channels also be capable of carrying voice traffic. For example, you might order a line with one B channel provisioned for data and the other B channel for alternate voice and data. If you intend to use a router with the optional analog module (for use with a phone, modem, or fax machine), then you need at least one B channel capable of carrying voice traffic.

- If appropriate, information as to whether the D channel is capable of carrying X.25-type packet data in addition to call setup and signaling information

This capability is not used by the NETGEAR routers.

- The number of directory numbers required

We recommend that NETGEAR or other Bay Networks products have only one directory number per ISDN line, although two are required on a Northern Telecom switch.

- Additional features required

Features vary depending on your telephone company. However, some common features that you might want are:

— Caller ID

This feature is sometimes known as calling party number delivery. One of the more powerful security features of the router is the use of caller ID to check the origin of incoming calls. NETGEAR recommends that you order Caller ID if it is available in your area. The feature you need might also be referred to by the telephone company as calling party or billing number deliver. This feature is different from the one known as Individual Caller Line Identification Display (ICLID). ICLID provides caller identification information in a human-readable format for ISDN telephones with display panels. It is not used by your NETGEAR router.

— Call waiting

This feature is sometimes known as additional call offering.

— Flexible calling features

This feature handles such things as call holding, call transfer, and conference calling. See the documentation for your phone for further details.

To simplify ordering in North America, National ISDN provides a set of ISDN Ordering Codes (IOCs) that allow service packages to be ordered. When there is only a NETGEAR router on a line, we recommend that you use the IOC called Capability J, which provides the following:

- Two B channels, with one configured for data and the other for alternate voice and data
- No packet data on the D channel
- One directory number for AT&T and Siemens switches and two for Northern Telecom switches
- Caller ID enabled for both voice and data services

## **Hunt Groups**

If you have multiple Basic Rate lines connected to a single unit, we recommend that you arrange with the telephone company to have them placed in a hunt group under a single telephone number. Each line still has its own individual directory number(s). Having a hunt group enables a caller to connect to the first available B channel, without the trouble of having to try alternative numbers in the event of a busy signal. This is especially important with Northern Telecom switches, because of their use of two directory numbers per line.

## **Long Distance Service**

If you are planning on sending digital data over long distance circuits, you need to choose a long distance carrier when ordering your ISDN line. You should make sure that your long distance carrier is capable of carrying 64 KBps circuit-switched digital data from your local telephone company switch into its network, and from its network to the data's ultimate destination. In some instances, you might have to settle for 56 KBps circuits. You must remember to make allowances for the circuit when making calls over long distance circuits.

You should contact your long distance carrier separately to order ISDN data service. You should do this even if you notify your local telephone company of your choice of long distance carrier, or even if you use a prefix such as 10-ATT to select the carrier on a call-by-call basis.

## Connecting to ISDN in Europe

ISDN has been available for a number of years in Europe, but a standard has now been agreed upon. It is known as Euro-ISDN. This version replaces the previous version of ISDN for each country, and telephone companies and network providers are now upgrading their older ISDN switches for the newer Euro-ISDN.

The NETGEAR Model RT210 router is approved to attach to both the French and German Euro-ISDN networks. The French and German Euro-ISDN networks differ slightly from the standard Euro-ISDN network approvals.

To connect to ISDN, you must request an ISDN line from the local telephone company and make sure that Euro-ISDN is installed. If only the older version of ISDN is available, make sure it has been upgraded to be Euro-ISDN compatible. The telephone company provides you with an ISDN telephone number that you must use when installing the NETGEAR Model RT210 and Model RT211 ISDN routers.

## Line Ordering Summary for North American Users

When ordering your ISDN line, you should do the following:

1. **Call your telephone company and ask what type of ISDN service is available in your area.**

The type of ISDN service is either National ISDN (available on AT&T, Northern Telecom, and Siemens switches) or AT&T Custom.

2. **Decide how many Directory Numbers and what other features you need, as described above.**

NETGEAR recommends that you order Caller ID if it is available in your area.

3. **Provide the appropriate provisioning information to the telephone company.**
4. **Make a note of the switch type, directory numbers, and SPIDs provided to you by the telephone company.**

All of this information is required when configuring your router.

## **Line Ordering Summary for European Users**

When ordering your ISDN line, you should do the following:

1. **Call your telephone company and ask what type of ISDN service is available in your area.**

Your ISDN circuit should conform to EURO-ISDN, NET3, or 1-CTR3 standards.

This information is required when configuring your router.

2. **Know the ISDN numbers of your local and remote sites.**
3. **Order the CLI option from your local carrier if you require CLI for security.**
4. **Order both B channels to have the same ISDN number, if possible. This is sometimes known as Auxiliary Working and can speed up connection times.**



---

# Appendix D

## Upgrading Software

This appendix gives you instructions on how to install the latest version of internal software through a locally attached PC or from a remote router of the same type.

The internal software on the NETGEAR Model RT210 and Model RT211 ISDN routers can be updated as new versions are released by NETGEAR. There are two components of the internal software: the routing software and TA software. You can update both using the procedures described in the following sections.

### Obtaining the Latest Version of Software

You can check to see what version of routing software is running on your router by typing VER from within the built-in interface.

To find out about the latest version through the Internet, refer to [“World Wide Web”](#) in the Preface for the NETGEAR home address. Information can be found on the Internet about the latest software release and also a copy of the software that you can download to upgrade your router.

To find out about the latest version through Customer Support, refer to [“Customer Support”](#) in the Preface to find the number for Customer Support in your area. If you do not have the latest software release, a copy of the software can be mailed to you.

All software upgrades are subject to the release being compatible with the hardware that you are using. Compatibility information is posted on the NETGEAR page on the Internet and is available through Customer Support.

## Upgrading Through a PC

Upgraded routing software can be installed by connecting a computer to your router through a LAN connection.

To install the software through a LAN connection, you need a computer equipped with the following:

- An Ethernet LAN interface card and packet driver software for that card loaded at software interrupt 0x66
- The following software:
  - CLAMPROG.EXE used to upgrade the router
  - ISDNPROG.EXE used to upgrade the TA code
  - PKUNZIP.EXE used for software updates supplied in a compressed format



**Note:** CLAMPROG.EXE and ISDNPROG.EXE expect the packet driver to be loaded at interrupt 0x66 by default, but this default can be overridden by the [-i<INT>] optional parameter on the command line.

---

Example: CLAMPROG.EXE CLAMR.BIN -i63 would program the router through a packet driver loaded at interrupt 0x63.

To install the software, follow these steps:

**1. Load the packet driver at the appropriate interrupt on your PC.**

Depending on the driver you have, you might need to be running in DOS mode rather than Windows.

**2. If your router is connected to a hub, disconnect it and connect it directly to the PC so that the PC and router are isolated from the rest of your LAN.**

Only one router at a time can be updated by using this procedure.

**3. Type DEFCON to connect to the built-in interface of the router and clear the configuration.**

Allow the router to reboot.



4. **Connect to the built-in interface and type BOOTMODE on the command line to place the router in the updating state.**

Alternatively, turn on the power with pins 7 and 8 of the LAN interface shorted. When in boot mode, the LED on the router flashes orange.

5. **Run CLAMPROG <newcode.bin> from the DOS command line to send the new software from the PC to the router.**

A series of dots is displayed on the screen as the data downloads to the router. Wait until the PC reports that the download is complete.

6. **Turn off the power to the router and turn it back on again.**

## Upgrading Through a Remote Router

You can install upgraded software through an ISDN connection by connecting a remote router that has already been upgraded to your router.

To install the software through a remote router, you need the following:

- Your router connected to another remote router through ISDN
- A computer connected into the Manager port of the router

The computer must be set up with ANSI terminal emulation software.

To install the software, follow these steps:

1. **Connect to the built-in interface of the target router and type DEFCON to clear the configuration.**

Allow the router to reboot.

2. **Type BOOTMODE from the built-in interface of the target router to place the router in the updating state.**

Alternatively, turn the power on with pins 7 and 8 of the LAN interface shorted. When in boot mode, the LED on the router flashes orange.

3. **Type SENDPROG <ISDN phone number of the target unit> from the built-in interface of the source router to send the new software to the target router.**

A series of messages are displayed on the source router that show the progress of what is happening.

4. **Turn off the power to the target router and turn it back on again.**

## Upgrading the Terminal Adapter Code

To display the version of the TA code, from the manager command prompt, issue the following commands:

1. **Type %TA% 1 60 and press enter twice.**

#00:ERROR> is displayed on the screen.

2. **Enter #01:ATE1**

#01:OK is displayed on the screen.

3. **Enter #01:ATVER**

The current version of the TA code is displayed.

The number 60 following the command is the time out in seconds for the unit to return back to the command prompt. If no time out is specified, the unit stays connected to the TA until it is power-cycled or reset.

To upgrade the TA code, follow these steps:

1. **Load the packet driver at the appropriate interrupt on your PC.**

Depending on the driver you have, you might need to be running in DOS mode rather than Windows.

2. **If your router is connected to a hub, disconnect it and connect it directly to the PC so that the PC and router are isolated from the rest of your LAN.**

Only one router at a time can be updated by using this procedure.

3. **Type %TAPROG% 1 from the built-in interface of the router to place the internal TA in the updating state.**

4. **Run ISDNPROG <newcode.bin> from the DOS command line to send the new software from the PC to the router.**

A series of dots are displayed on the screen as the data is downloaded to the router. Wait until the PC reports that the download is complete.

5. **Turn off the power to the router and turn it back on again.**

---

# Appendix E

## PPP Authentication Profiles

This appendix gives you information on determining Point-to-Point Protocol (PPP) profiles when configuring your router.

### Determining PPP Profiles

If you are dialing out into an Internet Service Provider or dialing into a central office, the use of PAP, CHAP, or Multilink is determined by the system administrator of the ISP or central office. You configure PPP based on the information you are given.

Otherwise, if you are responsible for both central and remote routers, you must determine the PPP profile based on the level of security and features you need. For additional information on security levels, refer to [“Defining Security Levels,”](#) [“Password Authentication Protocol,”](#) and [“Challenge Handshake Authentication Protocol”](#) on [page 1-8](#).

PPPProf not only specifies the security method, but also allows flexible connection to different implementations of PPP. The standard combinations should suit most configurations.

When Link Control Protocol (LCP) negotiation is not supported, or the unit is not required to be an Authenticator, then the Simple combinations should be selected. If no predefined combination is suitable, then a Custom profile can be built to allow compatibility with a particular system.

In Simple mode, the unit responds to a PAP or CHAP Authentication Request with the Password/Secret configured in the relevant path profile. In Standard mode, the unit acts as a PAP/CHAP Authenticator. This mode expects the remote unit (known as the Peer) to respond with the relevant PAP Password or CHAP response.

If calls are to be received from PPP routers that do not have paths configured in the router and CLI is not present, the ISDN PORT configuration must reflect the type of profile to be used to communicate with the calling router.

Use [Table E-1](#) through [Table E-4](#) to determine the appropriate PPP profile for your router based on security level, features, and the type of the connecting router.

**Table E-1. PPP authentication profiles**

Profile	PAP	CHAP	LCP Negotiation	LCP Authentication
CUSTOM	User	User	User	User
SIMPLE	No	No	No	No
SIMPLE CHAP	No	Yes	No	No
SIMPLE PAP	Yes	No	No	No
STANDARD CHAP	No	Yes	Yes	Yes
STANDARD CHAP & PAP	Yes	Yes	Yes	Yes
STANDARD PAP	Yes	No	Yes	Yes

**Table E-2. PPP authentication profiles for NETGEAR, Nautica, and Bay products**

Product Family	Operating Mode	Authentication Profile
(No authentication)	No PAP or CHAP	SIMPLE
BAY	PAP	SIMPLE
BAY	PAP & Multilink PPP	CUSTOM (1)
BAY	CHAP	CUSTOM (2)
BAY	CHAP & Multilink PPP	CUSTOM (2)
Nautica/NETGEAR	PAP	STANDARD PAP
Nautica/NETGEAR	PAP & Multilink PPP	CUSTOM (3)
Nautica/NETGEAR	CHAP	STANDARD CHAP
Nautica/NETGEAR	CHAP & Multilink PPP	CUSTOM (2)

**Table E-3. PPP custom authentication profiles for NETGEAR, Nautica, and Bay products**

<b>Operating Mode</b>	<b>Custom Default</b>	<b>Custom 1</b>	<b>Custom 2</b>	<b>Custom 3</b>
PAP	No	Yes	No	Yes
CHAP	No	No	Yes	No
LCP Negotiation	Yes	Yes	Yes	Yes
LCP Authentication	None	None	Both Ways	Incoming
MRU	1600	1600	1600	1600
LCP Echo Timer	6	6	6	6
CHAP Challenge Timer	60	60	60	60
Multilink	Yes	Yes	Yes	Yes
ML Short Sequence Number	Yes	Yes	Yes	Yes
ML Fragmenting	No	No	No	No
ML Encapsulation	No	Yes	Yes	Yes

**Table E-4. PPP authentication profiles for other manufacturers**

<b>Manufacturer</b>	<b>Operating Mode</b>	<b>Authentication Profile</b>
Ascend	PAP	STANDARD PAP
Ascend	PAP & Multilink PPP	STANDARD PAP
Ascend	CHAP	STANDARD CHAP
Ascend	CHAP & Multilink PPP	STANDARD CHAP
Cisco	No PAP or CHAP	SIMPLE
Cisco	PAP	STANDARD PAP
Cisco	CHAP	STANDARD CHAP
Network Express	PAP	STANDARD PAP
Spider/Shiva	ISDN (Needs CLI on earlier software releases)	CUSTOM PAP = No CHAP = No LCP Neg. = Yes MRU = 1518

# Glossary

<b>10BASE-T</b>	10 Mbps Ethernet over twisted pair wiring.
<b>B channel</b>	A 64 KBps “Bearer” channel used to carry voice or data over the ISDN network.
<b>BRI</b>	The ISDN Basic Rate Interface, composed of two B channels and one D channel.
<b>CLI</b>	<i>See</i> Caller Line Identification.
<b>Caller Line Identification</b>	Also known as Caller ID. The directory number of the caller is provided by the telephone company to the party called during call setup.
<b>D channel</b>	A 16 KBps channel used for signaling between the ISDN interface and the ISDN network. Sometimes used to carry X.25 packets. This channel controls call setup and tear down.
<b>IP</b>	<i>See</i> Internet Protocol.
<b>IP Address</b>	A 4-byte number uniquely defining each host on the Internet. Ranges of addresses are assigned by Internic, an organization formed for this purpose. Usually written in decimal with periods separating the bytes (Example is 134.177.244.57).
<b>IPX</b>	<i>See</i> Internet Packet EXchange.

<b>ISDN</b>	<i>See</i> Integrated Services Digital Network.
<b>ISP</b>	Internet Service Provider.
<b>Integrated Services Digital Network</b>	A digital telephone network for transmission of voice and data.
<b>Internet Packet Exchange</b>	Novell's internetworking protocol.
<b>Internet Protocol</b>	The main internetworking protocol used in the Internet. Used in conjunction with the Transfer Control Protocol (TCP) to form TCP/IP.
<b>LAN</b>	Local Area Network
<b>MP</b>	<i>See</i> Multilink Protocol.
<b>MRU</b>	<i>See</i> Maximum Receive Unit.
<b>MSN</b>	<i>See</i> Multiple Subscriber Numbering.
<b>Maximum Receive Unit</b>	The size in bytes of the largest packet that can be sent or received.
<b>Multilink Protocol</b>	An extension to the point-to-point protocol allowing the combination of both B channels to provide a single 128 KBps channel. <i>See</i> Point-to-Point Protocol.
<b>Multiple Subscriber Numbering</b>	A service of the telephone company in which a range of numbers is assigned to one line. Each device attached to that line (for example, a phone or router) must know which number it should answer.
<b>National ISDN (NI-1)</b>	Bellcore standard for first phase of ISDN interoperability among U.S. telephone companies.
<b>netmask</b>	<i>See</i> subnet mask.



<b>NT1 Network Termination 1</b>	Termination device that connects the user's equipment to the ISDN network. Converts the local equipment's four-wire S/T interface to the two-wire telephone company interface. The NT1 is provided by the telephone company in most of the world, but by the user in North America. Referred to in some areas as a DSU.
<b>numbered links</b>	<i>See</i> unnumbered links.
<b>PAP</b>	<i>See</i> Password Authentication Protocol.
<b>POTS</b>	<i>See</i> Plain Old Telephone Service.
<b>PPP</b>	<i>See</i> Point-to-Point Protocol.
<b>PSTN</b>	Public Switched Telephone Network.
<b>Password Authentication Protocol</b>	A method of enabling security on PPP links. When the link is established, a password is sent by the caller. <i>See</i> Challenge Handshake Authentication Protocol.
<b>Plain Old Telephone Service</b>	The standard analog phone system.
<b>Point-to-Point Protocol</b>	Protocol allowing a computer using TCP/IP to connect directly to the Internet.
<b>RIP</b>	<i>See</i> Routing Information Protocol.
<b>Routing Information Protocol</b>	A protocol in which routers periodically exchange information with each other so that they can determine minimum distance paths between sources and destinations.
<b>SPIDs</b>	<i>See</i> Service Profile Identifiers.
<b>S/T Interface</b>	The four-wire ISDN interface or reference point at the user or local side of the NT1. <i>See</i> U interface.

<b>Service Profile Identifier</b>	A number assigned by the telephone company to an attached device, used to identify the characteristics of that device.
<b>subnet mask</b>	A number that explains which part of an IP address comprises the network address and which is a subnet of host addresses. Can be expressed in the form of the IP address or as a number appended to the IP address. For example, a 28-bit mask starting from the MSB can be shown as 255.255.255.192 or as /28 appended to the IP address.
<b>U Interface</b>	The two-wire ISDN interface or reference point at the telephone company side of the NT1. <i>See</i> S/T interface.
<b>unnumbered links</b>	A method of connecting two LANs via a WAN where the two WAN end points do not have their own IP addresses.
<b>WAN</b>	<i>See</i> Wide Area Network.
<b>Wide Area Network</b>	A long distance link used to extend or connect remotely located Local Area Networks.

## A

- analog voice module, 1-2
- ARP table, B-4
- AT&T 5ESS, C-3
- autocall operation, 3-13

## B

- B channel
  - configuring with basic setup, 3-9
  - second, 3-9
- bandwidth, increasing, 3-14
- Basic Rate Interface (BRI) implementation, 1-3
- basic rate ISDN, C-1
- BOOTMODE command, D-3
- built-in interface
  - Basic Setup, 3-7
  - Quick Setup, 3-2

## C

- cable connections, 2-7
- Caller Line Identification, 3-14
  - integrated services digital network, 1-8
  - security, 1-8
  - using in connecting routers, 3-10
- Challenge Handshake Authentication Protocol.
  - See CHAP, 1-8
- changing password, 3-8
- CHAP, 1-8
  - authentication, 3-11
  - security, 1-8
  - using with PPP, 3-11

- CLAMPROG command, D-3
- Class B address, B-3
- clearing codes, 5-2
- clearing codes, internal, 5-3
- CLI. See Caller Line Identification, 3-14
- Configuration Menu, 3-8
  - IP routes list, 4-13
  - PPP custom parameters, 4-14
- Configure Paths Menu, 3-8
- Configure Ports Menu, 3-9
- configuring
  - B channel, 3-9
  - ISDN line, 3-9
  - methods, 3-1
  - with basic setup, 3-7
  - with quick setup, 3-4
- connecting
  - across local area network, 2-12
  - HyperTerminal and Windows '95, 2-13
  - Microsoft Terminal, 2-13
  - PC, 2-13
  - router using PPP, 3-11
  - serial port, 2-12
  - TCP/IP Telnet, 2-12
  - VT100 emulation, 2-13
  - Windows 3.1, 2-13
- conventions, xvi
- convergence, 1-5
- crossover cable, 2-11

## D

Declaration of Conformance, ii  
DEFCON command, D-3  
determining PPP profiles, E-1  
dialing remote device, 3-6  
directory number, basic setup, 3-9

## E

entering password, 3-5  
erase configuration, 3-7  
Ethernet 10BASE-T cables, 2-7  
European Services checklist, 2-3

## F

FCC statement, ii  
features  
    analog voice module, 1-2  
    built-in screen interface software, 1-2  
    calling line identification, 1-2  
    CHAP, 1-2  
    FirstGear software, 1-2  
    four-wire S/T interface on RT210, 1-2  
    Internet Protocol routing support, 1-2  
    ISDN connection, 1-2  
    management, 1-2  
    management support, 1-3  
    multilink PPP support, 1-3  
    PAP, 1-2  
    security, 1-2  
    speed, xv  
    TCP/IP support, 1-3  
    two-wire U interface on RT211, 1-2  
FirstGear Utility, 2-12, 3-1

## H

host address, 3-14  
Host Cache, B-4  
hunt groups, C-5

## I

installation  
    package contents, 2-1  
    router, 2-4  
    site preparation, 2-2  
integrated services digital network. *See* ISDN  
interface  
    converting from S/T to U, 1-6  
    four-wire S/T, 1-6  
    two-wire U, 1-6  
internal processes, showing, 5-1  
IP address  
    basic setup, 3-8  
    classes, B-2  
    entering, 3-5  
    formats, 3-5  
    resolution, B-4  
    single host, 3-14  
IP addressing  
    description, B-1  
IP RIP, B-5  
ISDN  
    basic rate interface and, 1-3  
    call clearing codes, 5-2  
    Call waiting, C-4  
    Caller ID, C-4  
    calling line identification, 1-8  
    cancelling a call, 3-10  
    configuring path between two NETGEAR/Bay  
        Networks routers, 3-10  
    configuring the line, 3-6, 3-9  
    connecting in Europe, C-6  
    connecting in North America, C-2  
    connecting to Basic Rate ISDN, C-1  
    connecting to ISDN, 1-3, 1-6  
    European standard, C-6  
    flexible calling features, C-5  
    France, C-6  
    Germany, C-6  
    internal clearing codes, 5-3  
    loopback test, 5-4  
    most common problems, 5-4

- multiple subscriber numbering, 1-7
- national standards, C-2
- ordering a line, C-1
- ordering line in Europe, C-7
- ordering line in North America, C-6
- routing IP over ISDN, B-5
- S/T interface, 2-8
- security, 1-8
- services checklist, 2-3
- subaddressing, 1-7
- switch types, C-3
- terminal adapter port, 1-1
- troubleshooting, 5-4
- U interface, 2-8

ISDN Port Status menu, 3-10

ISDNPROG command, D-4

## L

LAN

- testing path from PC to remote device, 5-8
- testing path to router, 5-5

leased circuit, 1-5

Link Control Protocol, E-1

long distance circuits, C-5

loopback test, 5-4

## M

MAC address, B-4

Main Menu, 4-1

management system

- configuration, 1-3
- connecting through Manager port, 1-4
- connecting through Telnet, 1-4
- software upgrades, 1-4

manual conventions, xvi

MDIX port, 2-11

MSN

- subaddressing, 3-15
- using, 1-7

Multilink PPP, 1-3

multilink. *See* multilink PPP

multiple subscriber numbering. *See* MSN

## N

naming router

- basic setup, 3-8
- Quick Setup, 3-6

National ISDN service packages, C-4

netmask format, 3-5

network

- address, 3-8
- checklist, 2-4
- entering address, 3-8
- interconnecting, 1-4

network termination device, 1-6, 2-8

North American Services checklist, 2-3

Northern Telecom DMS-100 and DMS-250  
Series, C-3

NT1. *See* network termination device

numbered link, 3-12

## P

package contents, 2-1

PAP

- Authentication, 3-11
- Challenge Handshake Authentication Protocol  
(CHAP), 3-11
- using with PPP, 3-11

password authentication protocol. *See* PAP

password, basic setup, 3-7

path management

- screen, 4-6
- Update Path forms, 4-7

paths, preconfiguring, 3-11

piggyback update, B-5

PING command, 4-20

planning considerations, 1-4

Point-to-Point Protocol. *See* PPP

ports

- configuring, 4-11
- updating, 4-11

PPP

- authentication profiles, E-2
- configuring a path, 3-12
- connecting routers, 3-11
- connecting to other devices, 1-7
- connecting to other router, 3-11
- multilink, 1-7
- password authentication and, 1-8

procedure

- configure ISDN line, 3-9
- enter network address, 3-8
- name the router, 3-8
- set up a call between two routers, 3-10

publications, xvii

## R

remote device

- call profile problems, 5-7
- line configuration problems, 5-7
- network configuration problems, 5-7
- physical connection problems, 5-6
- testing path, 5-6
- testing path to PC, 5-8

RIP, 1-5

router

- configuring using Basic Setup, 3-7
- connecting to a hub, 2-10
- connecting to ISDN in North America, 2-7
- connecting to other devices, B-6
- connecting using PPP, 3-12
- description, 1-1
- entering network address, 3-8
- installation, 2-4
- naming, 3-8
- testing LAN path, 5-5
- testing path to remote device, 5-6

routing

- across ISDN, 1-6
- definition, 1-4
- IP over ISDN, B-5
- protocol time-out, 1-6
- updates, 1-5

Routing Information Protocol. *See* RIP

## S

S/T interface, 2-8

saving configuration, 3-6

screen

- configuration menu, 4-4

security

- calling line identification, 1-8
- improving with Challenge Handshake Protocol, 1-8
- integrated services digital network, 1-8
- management access control, 1-2
- using Password Authentication Protocol, 3-11

selecting switch type, basic setup, 3-9

semipermanent routes, 1-6

SENDPROG command, D-3

serial port built-in interface access, 2-13

Service Profile Identifier. *See* SPID

session, 1-4

setting up PPP, 3-6

Siemens EWSD, C-3

Simple mode, E-1

site preparation, 2-2

software, upgrading, D-1

SPID

- basic setup, 3-9
- default, C-2
- obtaining, C-2
- receiving from telephone company, 1-6

spoofing, B-5

subaddress, 1-7, 3-15

subnet addressing, B-3  
support,customer. *See* customer support  
switch types, C-3

## T

### TCP/IP

- configuration requirements, 2-4
- routing, B-1
- support, 1-3
- using, 1-7

### Telnet connection, 2-13

- connecting to built-in interface, 2-13
- setting IP address, 2-13

time-out, routing protocol, 1-6

Trace Window, 5-1

Transfer Control Protocol/Internet Protocol. *See*  
TCP/IP

TW command, 5-1

## U

U interface, 2-8

unnumbered links, B-5

Update System Parameters Form, 4-5

Update System Parameters screen, 3-8

upgrading software, D-1

## V

voice port, testing, 5-8

## W

WAN link, B-6

workstation, setting for Telnet connection, 2-13

