



Quick Start Guide



Cisco Small Business Model SD208P 8-Port 10/100 Unmanaged Switch with PoE

Package Contents

- SD208P Switch
- Power Adapter
- Quick Start Guide

1 Product Overview

Thank you for choosing the SD208P 8-Port 10/100 Mbps switch. It is compliant with most popular network standards, and migrates Ethernet and Fast Ethernet networks seamlessly. It is equipped with 8 auto-negotiating 10/100 Mbps ports, capable of identifying and determining the best transmission speed to build the connection.

The SD208P supports IEEE 802.3af Power over Ethernet on ports 1 through 4 with a total power budget of 32 Watts. This provides power over Cat-5 cabling to PoE end devices such as wireless access points, IP phones or other PoE powered devices to help eliminate the need for dedicated electrical outlets. Furthermore, auto MDI/MDI-X on each port makes your network configuration easier than ever.

The SD208P has a built in feature to aid network performance at times of excessive load called Port Priority. This feature integrates Port Based QoS on all 8 ports to meet different service requirements on voice, video and data transformation. This feature can be useful during excessive loads, for example, when one type of traffic may require priority over another.

Front Panel

The LEDs are located on the front panel of the Switch.



Power—(Green) This LED lights up and remains lit when the Switch is powered on.

Link/ACT (1-8)—(Green) One LED per port, lights up when a connection is made (Link up) through the corresponding port. The LED will flash when there is activity (Tx or Rx) on the corresponding port.

PoE Status (1-4) (Green) These LEDs light up and remain lit when the switch is providing PoE power on the port (only for ports 1-4).

PoE Max (Yellow) This LED lights up and remains lit when the switch is providing more than 80% maximum PoE power (when the total power supplied reaches the 25.6 W level across ports 1-4)

Back Panel

The Ethernet network ports are located on the back panel of the Switch. All ports are auto-negotiating and have automatic MDI/MDI-X crossover detection.



Ethernet Ports—Ports 1-4 are high priority PoE ports with a total power budget of 32 watts. Ports 5-8 are low priority ports without PoE. The priority ratio of ports 1-4 to ports 5-8 is 4:1.

Power—Port for an external power adapter with 48V/1.25A DC output that supports 100/240 V and 50/60 Hz inputs.

Side Panels

There is a physical security slot located on the side of the Switch. The security slot is where you can attach a lock to protect the Switch from theft.

Placement Options

Set the Switch on its four rubber feet, or mount the Switch on a wall.

Before mounting the switch onto a wall, it is important to consider the following:

- Ensure the wall is strong enough to support the switch, a minimum of 1/2" of sheet rock is recommended.
- Do not operate the switch in an area that has reduced air flow, or exceeds an ambient temperature of 104 degrees (40 C).
- The switch can be mounted either horizontal or vertical.
- Mounting screws should have a head 5.5mm wide, 2mm deep, and the shaft of the screw should be at least 13mm long and 2.9mm wide.

To use the wall-mount option, follow these instructions:

STEP 1 The wall-mount slots are two crisscross slots on the Switch's bottom panel. Attach two screws to the wall 64mm apart.

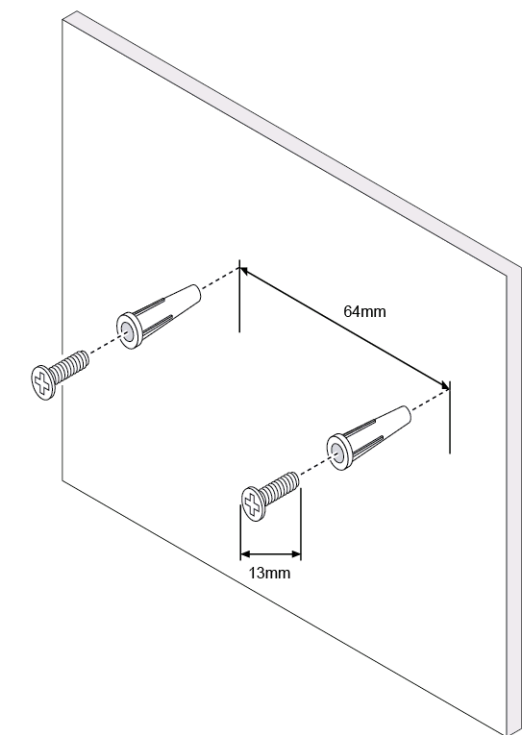

STEP 2 Maneuver the Switch to insert the screws into the two slots, then slide the switch downward onto the screws.

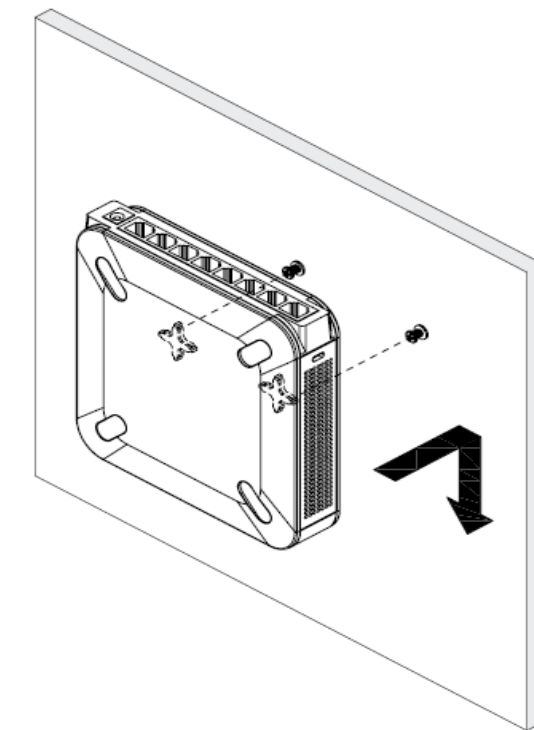

2 Typical Installation Scenario

The application diagram shown here is an example of a typical network configuration.

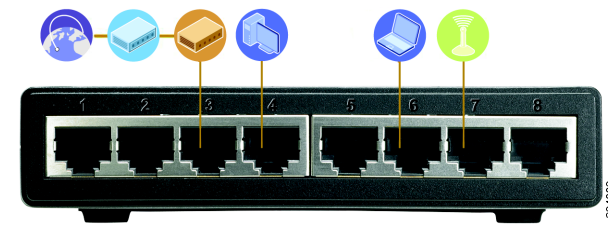

When you connect your network devices, make sure you don't exceed the maximum cabling distances, which are listed in the following table:

From	To	Maximum Distance
Switch	Switch or Hub	100 meters (328 feet)
Switch or Hub	Computer	100 meters (328 feet)

3 Installation

Perform the steps in this section to install the hardware.

STEP 1 Connect a Category 5 Ethernet cable to one of the numbered ports on the Switch. Connect the other end to a computer or other network device.

NOTE Use Category 5e Ethernet network cables for your Gigabit connections.

STEP 2 Repeat step 1 to connect additional devices.

STEP 3 Connect the supplied power adapter to the power port on the Switch. Plug the other end of the adapter into an electrical outlet.

CAUTION Make sure you use the power adapter included with the Switch. Using a different power adapter may damage the Switch.

STEP 4 Power on the devices connected to the Switch. Each active port's corresponding LED will light up on the Switch.

Congratulations! The installation of the Switch is complete!

4 Specifications

The following table lists the specifications for the SD208 10/100 Ethernet Switch.

Item	Specification
Model	SD208P
Standards	IEEE 802.3, 802.3u, 802.3x, 802.3ab, 802.3af
Ports	8 RJ-45 10/100 Mbps ports
Cabling Type	Cat5 Ethernet
LEDs	Power, Link/ACT 1 through 8, PoE Status 1 through 4, PoE Max
Security Feature	Security Slot
Dimensions	WxHxD 5.51" x 1.31" x 5.51" 140x33.35x140 mm
Unit Weight	0.723 lbs (0.328Kg)
Power	DC48V/1.25A
Certification	FCC Class B, CE
Operating Temperature	0°C to 40°C (32°F to 104°F)
Storage Temperature	-40°C to 70°C (-40°F to 158°F)
Operating Humidity	20 to 95%, relative humidity, Non-Condensing
Storage Humidity	5% to 90% Non-Condensing

5 Where to Go From Here

Resource	Location
Technical Documentation	www.cisco.com/en/US/products/ps10007/tsd_products_support_series_home.html
Customer Support	www.cisco.com/web/products/index.html
End User License Agreement	www.cisco.com/go/warranty
Regulatory Compliance and Safety Information	www.cisco.com/en/US/products/ps10007/tsd_products_support_series_home.html
Warranty Information	www.cisco.com/go/warranty
Cisco Partner Central site for Small Business	www.cisco.com/web/partners/sell/smb/

Americas Headquarters
Cisco Systems, Inc.
170 West Tasman Drive
San Jose, CA 95134-1706
USA
<http://www.cisco.com>
Tel: 408 526-4000
800 553-NETS (6387)
Fax: 408 527-0883



Cisco, Cisco Systems, the Cisco logo, and the Cisco Systems logo are registered trademarks or trademarks of Cisco Systems, Inc. and/or its affiliates in the United States and certain other countries. All other trademarks mentioned in this document or Website are the property of their respective owners. The use of the word partner does not imply a partnership relationship between Cisco and any other company. (0705R)

© 2009 Cisco Systems, Inc. All rights reserved.
♻️ Printed in the USA on recycled paper containing 10% postconsumer waste.