

Drying Tumblers

50 Pound Capacity

75 Pound Capacity

Through Serial No. 0903xxxxx

Refer to Page 5 for Model Identification



Installation

NOTA: Para bajar una copia de estas instrucciones en español, visite www.comlaundry.com.

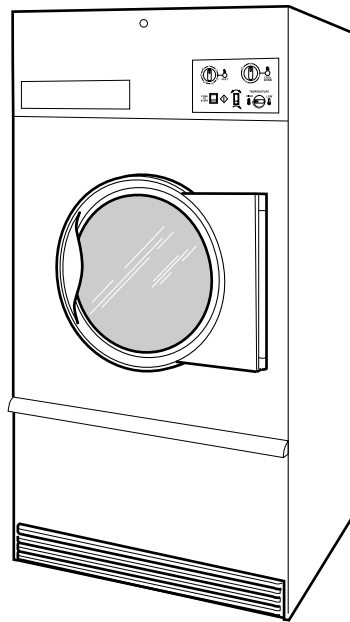

TMB795C

Keep These Instructions for Future Reference.

(If this machine changes ownership, this manual must accompany machine.)



www.comlaundry.com

Part No. M414905R12
March 2009

Installation must conform with local codes or, in the absence of local codes, with:

In the U.S.A., installation must conform to the latest edition of the American National Standard Z223.1/ NFPA 54 “National Fuel Gas Code” and Standard ANSI/NFPA 70 “National Electric Code.”

In Canada, installation must comply with Standards CAN/CSA-B149.1 or Natural Gas and Propane Installation Code and CSA C22.1, latest edition, Canadian Electric Code, Part I.

In Australia, installation must comply with the Australian Gas Association Installation Code for Gas Burning Appliances and Equipment.



WARNING

FOR YOUR SAFETY, the information in this manual must be followed to minimize the risk of fire or explosion or to prevent property damage, personal injury or death.

W033

- Do not store or use gasoline or other flammable vapors and liquids in the vicinity of this or any other appliance.
- **WHAT TO DO IF YOU SMELL GAS:**
 - Do not try to light any appliance.
 - Do not touch any electrical switch; do not use any phone in your building.
 - Clear the room, building or area of all occupants.
 - Immediately call your gas supplier from a neighbor’s phone. Follow the gas supplier’s instructions.
 - If you cannot reach your gas supplier, call the fire department.
- Installation and service must be performed by a qualified installer, service agency or the gas supplier.

W052



MISE EN GARDE

POUR VOTRE SÉCURITÉ, les informations de ce guide doivent être respectées afin de réduire les risques d’incendie, d’explosion ou d’éviter les dommages matériels, personnels ou blessures mortelles.

W033R3QU

- Ne pas entreposer ou utiliser d’essence ou toutes autres vapeurs et liquides inflammables à proximité de cette machine ou de tout autre appareil.
- **QUE FAIRE EN CAS D’ODEUR DE GAZ :**
 - Ne pas mettre d’appareil en marche.
 - Ne pas toucher aux interrupteurs électriques ; ne pas utiliser le téléphone des lieux.
 - Évacuer la pièce, le bâtiment ou la zone de tous les occupants.
 - Appeler immédiatement le fournisseur de gaz de la maison d’un voisin. Respecter les instructions communiquées par le fournisseur.
 - Si vous ne pouvez pas joindre le fournisseur de gaz, appeler le service d’incendie.
- L’installation et l’entretien doivent être effectués par un installateur, service d’entretien qualifiés ou par le fournisseur de gaz.

W052R5QU

IMPORTANT: Information must be obtained from a local gas supplier on instructions to be followed if the user smells gas. These instructions must be posted in a prominent location. Step-by-step instructions of the above safety information must be posted in a prominent location near the tumbler for customer use.



WARNING

- Installation of unit must be performed by a qualified installer.
- Install tumbler according to manufacturer's instructions and local codes.
- **DO NOT** install a tumbler with flexible plastic venting materials. If flexible metal (foil type) duct is installed, it must be of a specific type identified by the appliance manufacturer as suitable for use with tumbler. Refer to section on connecting exhaust system. Flexible venting materials are known to collapse, be easily crushed, and trap lint. These conditions will obstruct tumbler airflow and increase the risk of fire.

W752

FOR YOUR SAFETY

Do not store or use gasoline or other flammable vapors and liquids in the vicinity of this or any other appliance.

W053



MISE EN GARDE

- L'unité doit être installée par un installateur qualifié.
- Installer la sècheuse conformément aux instructions du fabricant et aux codes locaux.
- **NE PAS** installer une sècheuse avec des matériaux d'aération souples en plastique. Si un conduit d'aération souple en métal (de type feuille mince) est utilisé, il doit être d'un type spécifiquement mentionné par le fabricant de l'appareil comme convenable pour utilisation avec sècheuses. Se reporter à la section sur la façon de connecter le système d'évacuation. Les matériaux d'aération souples risquent de s'affaisser, ils s'écrasent facilement, et les fibres et les peluches s'y accumulent. Ces conditions obstruent l'écoulement de l'air et augmentent les risques d'incendie.

W752QU

POUR VOTRE SÉCURITÉ

Ne pas entreposer ou utiliser d'essence ou toutes autres vapeurs et liquides inflammables à proximité de cette unité ou de tout autre appareil.

W053R2QU

The following information applies to the state of Massachusetts, USA.

- This appliance can only be installed by a Massachusetts licensed plumber or gas fitter.
- This appliance must be installed with a 36 inch (91 cm) long flexible gas connector.
- A "T-Handle" type gas shut-off valve must be installed in the gas supply line to this appliance.
- This appliance must not be installed in a bedroom or bathroom.

Table of Contents

| | |
|---|----|
| Introduction | 5 |
| Model Identification | 5 |
| Customer Service..... | 7 |
| Wiring Diagram | 7 |
| Serial Plate Location..... | 7 |
| Safety Information | 8 |
| Important Safety Instructions | 9 |
| Specifications and Dimensions | 11 |
| Cabinet Dimensions..... | 12 |
| Exhaust Outlet Locations..... | 13 |
| Gas Connection Locations..... | 14 |
| Electrical Connection Locations..... | 15 |
| Steam Connection Locations | 16 |
| Installation | 17 |
| Pre-Installation Inspection..... | 17 |
| Location Requirements..... | 18 |
| Position and Level the Tumbler..... | 19 |
| Bolt-On Angle Option | 19 |
| To Reverse the Loading Door..... | 21 |
| Before Placing Tumbler into Service | 24 |
| Required for CE Models Only..... | 25 |
| Installing CE Gas Drying Tumblers | 25 |
| General Information..... | 25 |
| Basic Configuration | 27 |
| Specific Conversion Procedures | 27 |
| Exhaust Requirements | 30 |
| Layout..... | 30 |
| Make-Up Air..... | 30 |
| Venting | 30 |
| Individual Venting | 31 |
| Manifold Venting..... | 31 |
| Gas Requirements | 35 |
| Gas Supply Pipe Sizing and Looping | 37 |
| High Altitude Burner Orifice Sizing..... | 39 |
| Electrical Requirements | 40 |
| Grounding Instructions | 40 |
| For CE Models Only..... | 40 |
| Service/Ground Location..... | 41 |
| To Connect Electrical Service To The Tumbler..... | 42 |
| Jumper Configuration Instructions | 44 |
| Ferrite Ring Installation..... | 44 |
| 50 Pound Gas and Steam Models | 45 |
| 75 Pound Gas and Steam Models | 46 |
| 50 and 75 Pound Electric Models..... | 47 |

© Copyright 2009, Alliance Laundry Systems LLC

All rights reserved. No part of the contents of this book may be reproduced or transmitted in any form or by any means without the expressed written consent of the publisher.

| | |
|--|----|
| Steam Requirements | 48 |
| Piping Recommendations..... | 49 |
| Installing Steam Trap and Making Condensate Return Connections..... | 49 |
| Thermal Oil Prep..... | 49 |
| Single Drop Timer | 51 |
| Power-Up Mode..... | 51 |
| Ready Mode..... | 51 |
| Start Mode..... | 51 |
| Run Mode..... | 51 |
| Setting Dry Time Dipswitches..... | 51 |
| Dipswitch Settings..... | 52 |
| Rotary Coin Drop Timer | 54 |
| Installing Accessory Timing Cam..... | 54 |
| Removal of Existing Timing Cam..... | 54 |
| Installation of New Timing Cam..... | 54 |
| Adjustments | 55 |
| Gas Burner Air Shutter..... | 55 |
| Airflow Switch..... | 56 |
| Gas and Electric Tumblers..... | 56 |
| Loading Door Switch..... | 58 |
| Loading Door Catch..... | 58 |
| Drive Belt..... | 58 |
| Nonreversing Models..... | 58 |
| Reversing Models..... | 58 |
| Removing Tumbler from Service | 61 |

Introduction

Model Identification

Information in this manual is applicable to these models:

| | Gas | | Steam/Thermal Oil | | Electric |
|---------------------|----------------|----------------|-------------------|--------|----------------|
| 50 Pound | AT050L | HT050N | AT050S | UT050T | AT050E |
| | AT050N | HU050L | CHD50S2-CT050S | UU050S | CHD50E2-CT050E |
| | CHD50G2-CA050L | HU050N | CHD50S2-CU050S | UU050T | CHD50E2-CU050E |
| | CHD50G2-CA050N | IPD50G2-IT050L | CT050T | YT050S | DR55E2-BT050E |
| | CHD50G2-CT050L | IPD50G2-IT050N | CU050T | YT050T | DR55E2-BU050E |
| | CHD50G2-CT050N | NT050L | DR55S2-BT050S | | GT050E |
| | CHD50G2-CU050L | NT050N | DR55S2-BT050T | | GU050E |
| | CHD50G2-CU050N | SA050L | DR55S2-BU050S | | HT050E |
| | DR55G2-BA050L | SA050N | DR55S2-BU050T | | HU050E |
| | DR55G2-BA050N | ST050D | GT050S | | IPD50E2-IT050E |
| | DR55G2-BT050D | ST050L | GU050S | | ST050E |
| | DR55G2-BT050L | ST050N | HT050S | | SU050E |
| | DR55G2-BT050N | SU050L | HT050T | | UT050E |
| | DR55G2-BU050L | SU050N | HU050S | | UU050E |
| | DR55G2-BU050N | UA050L | HU050T | | YT050E |
| | GT050L | UA050N | IPD50S2-IT050S | | |
| | GT050N | UT050L | IPD50S2-IT050T | | |
| | GU050L | UT050N | ST050S | | |
| | GU050N | UU050L | ST050T | | |
| | HA050L | UU050N | SU050S | | |
| | HA050N | YT050L | SU050T | | |
| HT050D | YT050N | UT050S | | | |
| HT050L | | | | | |
| 75 Pound | AT075L | HU075N | AT075S | UU075T | AT075E |
| | AT075N | IPD75G2-IT075L | CHD75S2-CT075S | YT075S | CHD75E2-CT075E |
| | CHD75G2-CA075L | IPD75G2-IT075N | CHD75S2-CU075S | YT075T | CHD75E2-CU075E |
| | CHD75G2-CA075N | NT075L | CT075T | YU075S | DR80E2-BT075E |
| | CHD75G2-CT075L | NT075N | CU075T | YU075T | DR80E2-BU075E |
| | CHD75G2-CT075N | SA075L | DR80S2-BT075S | | GT075E |
| | CHD75G2-CU075L | SA075N | DR80S2-BT075T | | GU075E |
| | CHD75G2-CU075N | ST075D | DR80S2-BU075S | | HT075E |
| | DR80G2-BA075L | ST075L | DR80S2-BU075T | | HU075E |
| | DR80G2-BA075N | ST075N | GT075S | | IPD75E2-IT075E |
| | DR80G2-BT075D | STF75L | GU075S | | ST075E |
| | DR80G2-BT075L | STF75N | HT075S | | SU075E |
| | DR80G2-BT075N | SU075L | HT075T | | UB075E |
| | DR80G2-BU075L | SU075N | HU075S | | UT075E |
| | DR80G2-BU075N | UA075L | HU075T | | UU075E |
| | GT075L | UA075N | IPD75S2-IT075S | | YT075E |
| | GT075N | UT075L | IPD75S2-IT075T | | YU075E |
| | GU075L | UT075N | ST075S | | |
| | GU075N | UTF75L | ST075T | | |
| | HA075L | UTF75N | SU075S | | |
| | HA075N | UU075L | SU075T | | |
| HT075D | UU075N | UT075S | | | |
| HT075L | YT075L | UT075T | | | |
| HT075N | YT075N | UU075S | | | |
| HU075L | | | | | |

Control suffixes listed on the following page.

Introduction

Includes models with the following control suffixes:

| | | |
|--------------------------------------|------------------------------|--------------------------------------|
| 3O –DX4 OPL | DO –DMP OPL | RD –reversing DMP OPL |
| 3V –DX4 vended | DV –DMP vended | RM –reversing OPL micro |
| 3X –DX4 prep for coin | DX –DMP prep for coin | RQ –reversing dual digital timer |
| BC –basic electronic, coin | MT –manual timer | RT –reversing manual timer |
| BL –basic electronic, central pay | NC –NetMaster coin | SD –single drop |
| BU –basic electronic, prep card-open | NR –NetMaster card | SX –single drop, prep for coin |
| BX –basic electronic, prep for coin | NX –NetMaster, prep for coin | ZC –NetMaster network, coin |
| BY –basic electronic, prep for card | NY –NetMaster, prep for card | ZR –NetMaster network, card |
| CD –rotary coin drop | OM –OPL micro | ZX –NetMaster network, prep for coin |
| CX –prep for coin | QT –dual digital timer | ZY –NetMaster network, prep for card |
| CY –prep for card | R3 –reversing DX4 OPL | |

Customer Service

If literature or replacement parts are required, contact the source from which the machine was purchased or contact Alliance Laundry Systems at (920) 748-3950 for the name and address of the nearest authorized parts distributor.

For technical assistance, call (920) 748-3121.

Serial Plate Location

When calling or writing for information about your product, be sure to mention model and serial numbers. Model and serial numbers are found on serial plate on the rear of machine and inside door.

Wiring Diagram

The wiring diagram is located in the junction or contactor box.

Models starting Serial No. 0309 _____ or later will have the wiring diagram part number in the lower portion of the electrical data on the serial plate.

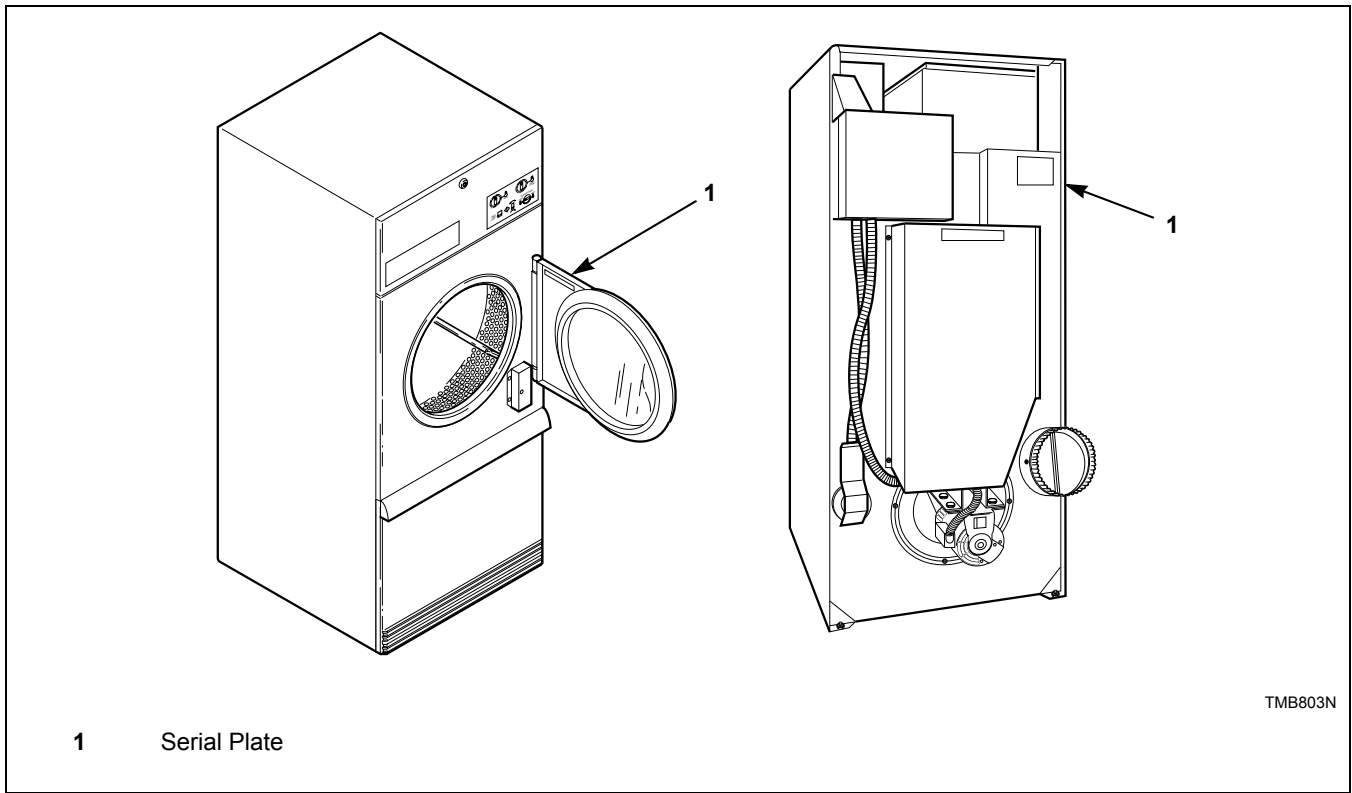



| Conversion Table | | | | | | |
|----------------------------|-------|-----------------|--|-------------------|---------|----------------|
| Multiply | By | To Obtain | | Multiply | By | To Obtain |
| Btu | 0.252 | kCal | | Pounds/sq. inch | 0.06895 | Bars |
| Btu | 1055 | Joules | | Pounds/sq. inch | 0.070 | kg/sq. cm |
| Inch | 25.4 | Millimeters | | Pounds (lbs.) | 0.454 | Kilograms |
| Inches W.C. | 0.036 | Pounds/sq. inch | | Boiler Horsepower | 33,479 | Btu/hr. |
| Inches W.C. | 0.249 | kPa | | Boiler Horsepower | 34.5 | lbs. steam/hr. |
| lb/inch ² (psi) | 6.895 | kPa | | CFM | 0.471 | liters/second |
| ft ³ | 28.32 | Liters | | kW | 3414 | Btu/hr. |

Safety Information

Precautionary statements (“DANGER,” “WARNING,” and “CAUTION”), followed by specific instructions, are found in this manual and on machine decals. These precautions are intended for the personal safety of the operator, user, servicer, and those maintaining the machine.

| | |
|---|---------------|
|  | DANGER |
| Indicates an imminently hazardous situation that, if not avoided, will cause severe personal injury or death. | |

| | |
|--|----------------|
|  | WARNING |
| Indicates a hazardous situation that, if not avoided, could cause severe personal injury or death. | |

| | |
|---|----------------|
|  | CAUTION |
| Indicates a hazardous situation that, if not avoided, may cause minor or moderate personal injury or property damage. | |

Additional precautionary statements (“IMPORTANT” and “NOTE”) are followed by specific instructions.

IMPORTANT: The word “IMPORTANT” is used to inform the reader of specific procedures where minor machine damage will occur if the procedure is not followed.

NOTE: The word “NOTE” is used to communicate installation, operation, maintenance or servicing information that is important but not hazard related.

| | |
|---|----------------|
|  | WARNING |
| Failure to install, maintain, and/or operate this machine according to manufacturer’s instructions may result in conditions which can produce serious injury, death and/or property damage. | |
| <small>W051R1</small> | |

NOTE: The WARNING and IMPORTANT instructions appearing in this manual are not meant to cover all possible conditions and situations that may occur. It must be understood that common sense, caution and carefulness are factors which CANNOT be built into this tumbler. These factors MUST BE supplied by the person(s) installing, maintaining or operating the tumbler.

Always contact your dealer, distributor, service agent or the manufacturer on any problems or conditions you do not understand.

Save These Instructions

Important Safety Instructions

| | |
|--|----------------|
|  | WARNING |
| <p>Hazardous Voltage. Can cause shock, burn or cause death. Allow machine power to remain off for two minutes prior to working in and around AC inverter drive.</p> | |
| W359 | |

1. Read all instructions before using the tumbler.
2. Refer to the **GROUNDING INSTRUCTIONS** for the proper grounding of the tumbler.
3. Do not dry articles that have been previously cleaned in, washed in, soaked in, or spotted with gasoline, dry cleaning solvents, other flammable or explosive substances as they give off vapors that could ignite or explode.
4. Do not allow children on or in the tumbler. This appliance is not intended for use by young children or infirm persons without supervision. Young children should be supervised to ensure that they do not play with the appliance.
5. Before the tumbler is removed from service or discarded, remove the door to the drying compartment and the door to the lint compartment.
6. Do not reach into the tumbler if the cylinder is revolving.
7. Do not install or store the tumbler where it will be exposed to water and/or weather.
8. Do not tamper with the controls.
9. Do not repair or replace any part of the tumbler, or attempt any servicing unless specifically recommended in the user-maintenance instructions or in published user-repair instructions that you understand and have the skills to carry out.
10. Do not use fabric softeners or products to eliminate static unless recommended by the manufacturer of the fabric softener or product.
11. To reduce the risk of fire, **DO NOT DRY** plastics or articles containing foam rubber or similarly textured rubberlike materials.
12. Always clean the lint filter daily.
13. Keep area around the exhaust opening and adjacent surrounding area free from the accumulation of lint, dust and dirt.
14. The interior of the tumbler and the exhaust duct should be cleaned periodically by qualified service personnel.
15. If not installed, operated and maintained in accordance with the manufacturer's instructions or if there is damage to or mishandling of this product's components, use of this product could expose you to substances in the fuel or from fuel combustion which can cause death or serious illness and which are known to the State of California to cause cancer, birth defects or other reproductive harm.
16. Tumbler will not operate with the loading door open. **DO NOT** bypass the door safety switch to permit the tumbler to operate with the door open. The tumbler will stop tumbling when the door is opened. Do not use the tumbler if it does not stop tumbling when the door is opened or starts tumbling without pressing or turning the START mechanism. Remove the tumbler from use and call for service.
17. Tumbler will not operate with lint panel open. **DO NOT** bypass lint panel safety switch to permit the tumbler to operate with the lint panel open.
18. Do not put articles soiled with vegetable or cooking oil in the tumbler, as these oils may not be removed during washing. Due to the remaining oil, the fabric may catch on fire by itself.
19. To reduce the risk of fire, **DO NOT** put clothes which have traces of any flammable substances such as machine oil, flammable chemicals, thinner, etc. or anything containing wax or chemicals such as in mops and cleaning cloths, or anything dry-cleaned at home with dry-cleaning solvent in the tumbler.
20. Use the tumbler only for its intended purpose, drying fabrics.
21. **ALWAYS** disconnect and lockout the electrical power to the tumbler before servicing. Disconnect power by shutting off appropriate breaker or fuse.
22. Install this tumbler according to the **INSTALLATION INSTRUCTIONS**. All connections for electrical power, grounding, and gas supply must comply with local codes and be made by licensed personnel when required.

Safety Information

23. Remove laundry immediately after tumbler stops.
24. Always read and follow manufacturer's instructions on packages of laundry and cleaning aids. Heed all warnings or precautions. To reduce the risk of poisoning or chemical burns, keep them out of reach of children at all times (preferably in a locked cabinet).
25. Do not tumble fiberglass curtains and draperies unless the label says it can be done. If they are dried, wipe out the cylinder with a damp cloth to remove particles of fiberglass.
26. Always follow the fabric care instructions supplied by the garment manufacturer.
27. Never operate the tumbler with any guards and/or panels removed.
28. **DO NOT** operate the tumbler if it is smoking, grinding, has missing or broken parts.
29. **DO NOT** bypass any safety devices.
30. Solvent vapors from dry-cleaning machines create acids when drawn through the heater of the drying unit. These acids are corrosive to the tumbler as well as to the laundry load being dried. Be sure make-up air is free of solvent vapors.
31. Failure to install, maintain, and/or operate this machine according to the manufacturer's instructions may result in conditions which can produce bodily injury and/or property damage.



WARNING

To reduce the risk of serious injury, install lockable door(s) to prevent public access to rear of tumblers.

W055

Specifications and Dimensions

| Specifications | 50 Pound | 75 Pound | F75 |
|---|---|--|------------------------|
| Noise level measured during operation at operator position of 3.3 feet (1 meter) in front of machine and 5.2 feet (1.6 meters) from floor. | 63 dBA | 69 dBA | 67 dBA |
| Net Weight (approximate): Pounds (kg) | 545 (247) | 615 (279) | 710 (322) |
| Cylinder Size: Inches (mm) | 37 x 30 (940 x 762) | 37 x 36 (940 x 914) | 37 x 36 (940 x 914) |
| Cylinder Capacity (dry weight): Pounds (kg) | 50 (22.7) | 75 (34) | 75 (34) |
| Air Outlet Diameter: Inches (mm) | 8 (203) | 8 (203) | 10 (254) |
| Maximum Static Back Pressure: W.C.I. (mbar) | 0.5 (1.3) | 0.5 (1.3) | 0.5 (1.3) |
| Maximum Airflow: C.F.M. (L/sec.) | 750 (354) | Gas/Steam 60 Hz 920 (434) Gas/Steam 50 Hz 750 (354) Electric 750 (354) | 1100 (518) |
| Motor Horsepower: Nonreversing Reversing Fan Cylinder | 1/2 1/3 1/3 | 3/4 1/3 1/3 | N/A 1 1/3 |
| Gas Models | | | |
| Gas Connection | 1/2 in. NPT | 1/2 in. NPT | 3/4 in. NPT |
| Gas Burner Rating: Btu/hr (Mj/hr) | 120,000 (126.6) | 165,000 (174.1) | 215,000 (227) |
| Electric Models | | | |
| Heating Element Rating: Kilowatts (kW) | 21 kW (240 V/50 Hz) 30 kW (other voltages) | 30 kW | N/A |
| Steam Models | | | |
| Steam Connection | 3/4 in. NPT | 3/4 in. NPT | N/A |
| Steam Coil Rating: Boiler Horsepower (Btu/hr) | 5.1 (177,500) | 6.1 (210,300) | N/A |

N/A = Not Applicable

Specifications and Dimensions

Cabinet Dimensions

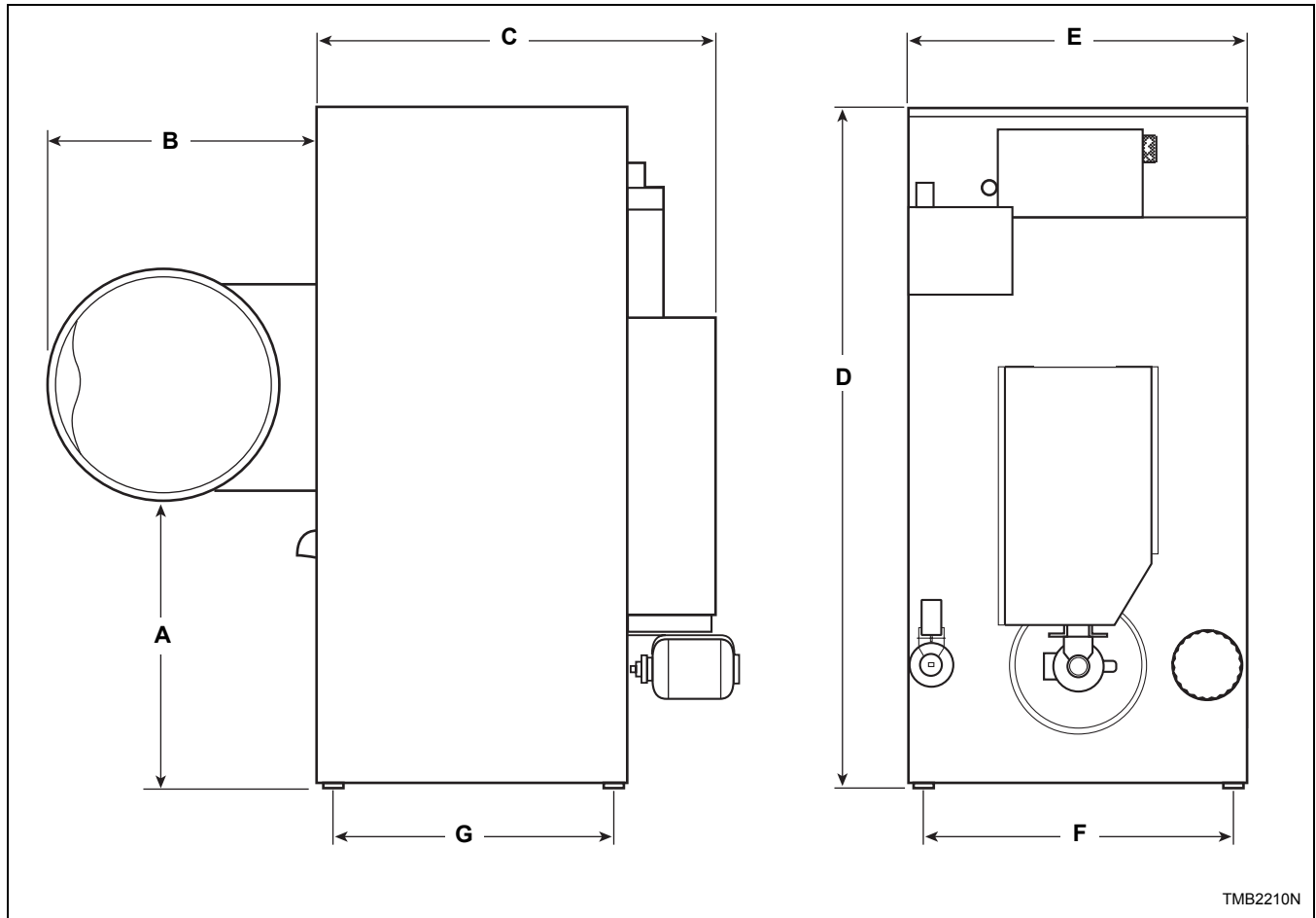

| Models | A | | B | | C | D | E | F | G |
|----------------------------------|-----------------------|-----------------------|-----------------------|-----------------------|---------------------|-------------------------|------------------------|--------------------|----------------------|
| | * | ** | * | ** | | | | | |
| 50 Pound Gas and Electric | 30.75 in. (781 mm) | 28.75 in. (730 mm) | 28.25 in. (717 mm) | 33.87 in. (860 mm) | 47 in. (1194 mm) | 76.625 in. (1946 mm) | 38.625 in. (981 mm) | 33 in. (838 mm) | 29.5 in. (749 mm) |
| 50 Pound Steam | 30.75 in. (781 mm) | 28.75 in. (730 mm) | 28.25 in. (717 mm) | 33.87 in. (860 mm) | 47 in. (1194 mm) | 80 in. (2032 mm) | 38.625 in. (981 mm) | 33 in. (838 mm) | 29.5 in. (749 mm) |
| 75 Pound Gas and Electric | 30.75 in. (781 mm) | 28.75 in. (730 mm) | 28.25 in. (717 mm) | 33.87 in. (860 mm) | 53 in. (1346 mm) | 76.625 in. (1946 mm) | 38.625 in. (981 mm) | 33 in. (838 mm) | 35.5 in. (902 mm) |
| 75 Pound Steam | 30.75 in. (781 mm) | 28.75 in. (730 mm) | 28.25 in. (717 mm) | 33.87 in. (860 mm) | 53 in. (1346 mm) | 80 in. (2032 mm) | 38.625 in. (981 mm) | 33 in. (838 mm) | 35.5 in. (902 mm) |
| F75 Gas | 30.75 in. (781 mm) | 28.75 in. (730 mm) | 28.25 in. (717 mm) | 33.87 in. (860 mm) | 53 in. (1346 mm) | 76.625 in. (1946 mm) | 38.625 in. (981 mm) | 33 in. (838 mm) | 35.5 in. (902 mm) |

* A, H, S and U models prior to Serial No. 0308001307 and all other models.

** A, H, N, S and U models after Serial No. 0308001307.

Exhaust Outlet Locations

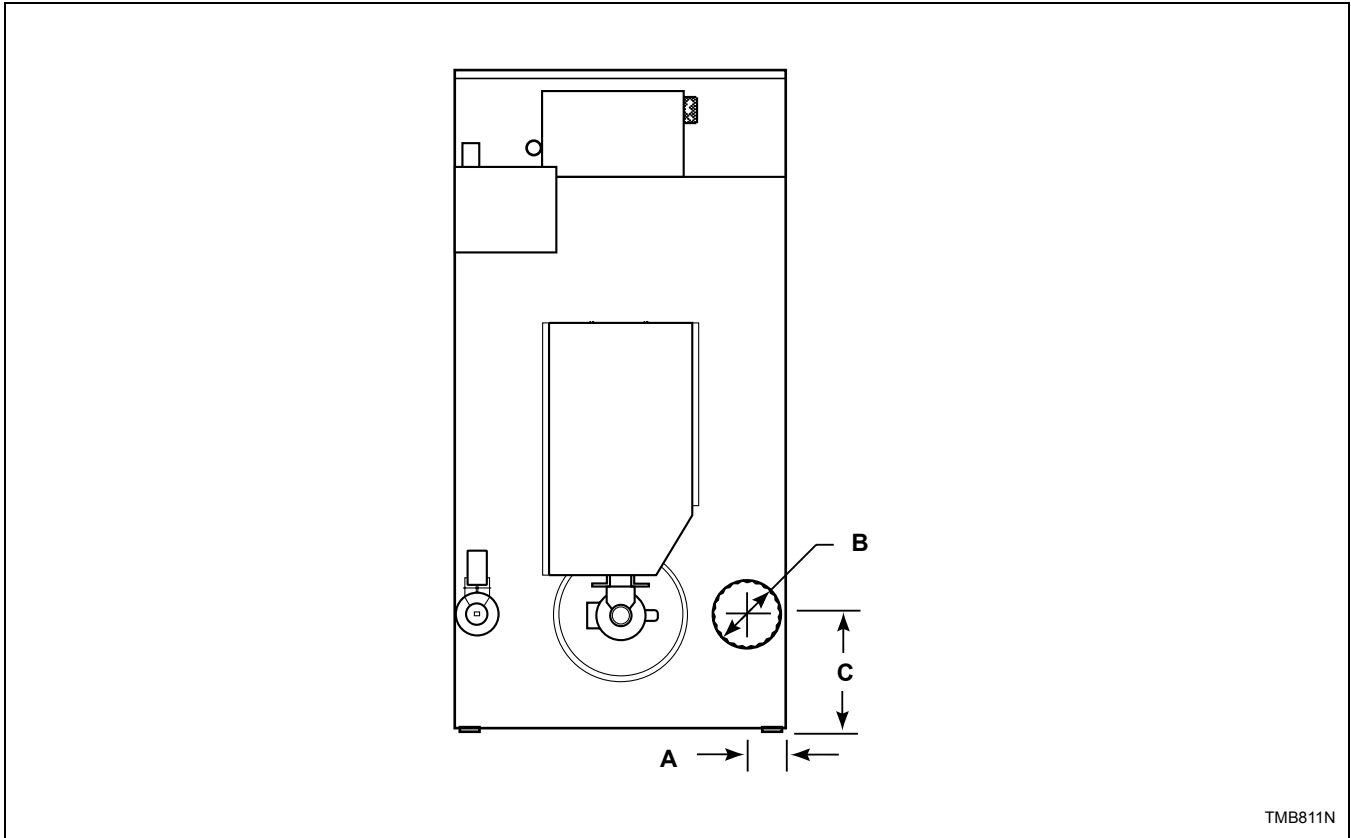

TMB811N

| Models | A | B | C |
|--------------------|-----------------------|--------------------|------------------------|
| 50/75 Pound | 5.375 in. (137 mm) | 8 in. (203 mm) | 13.375 in. (340 mm) |
| F75 | 6.5 in. (165 mm) | 10 in. (254 mm) | 6.5 in. (165 mm) |

Specifications and Dimensions

Gas Connection Locations

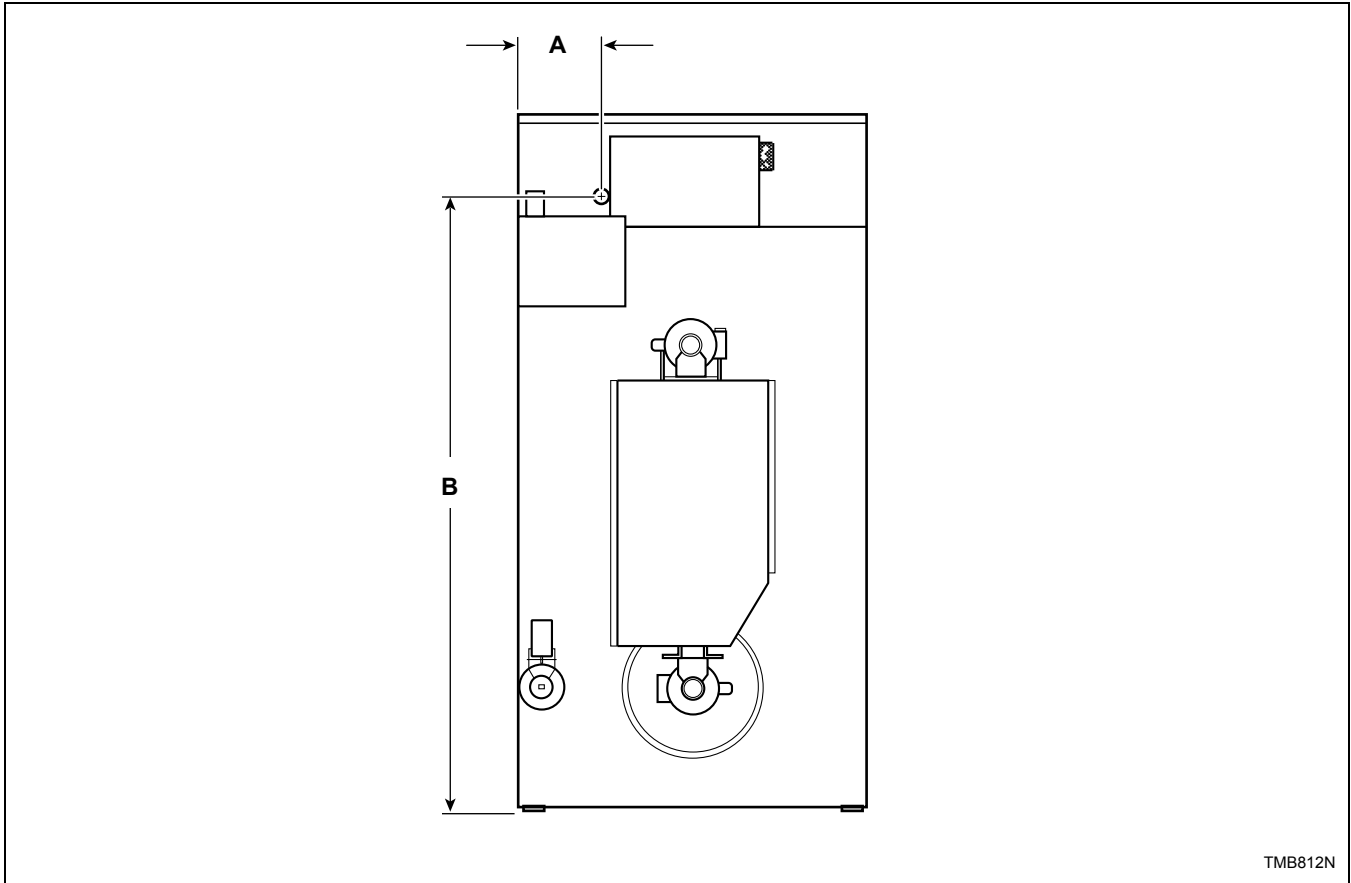

TMB812N

| Models | Diameter | A | B |
|-----------------|-----------------|-----------------------|------------------------|
| 50 Pound | 1/2 in. NPT | 15.5 in. (394 mm) | 65.75 in. (1670 mm) |
| 75 Pound | 1/2 in. NPT | 15.75 in. (400 mm) | 65.75 in. (1670 mm) |
| F75 | 3/4 in. NPT | 15.75 in. (400 mm) | 65.75 in. (1670 mm) |

Electrical Connection Locations

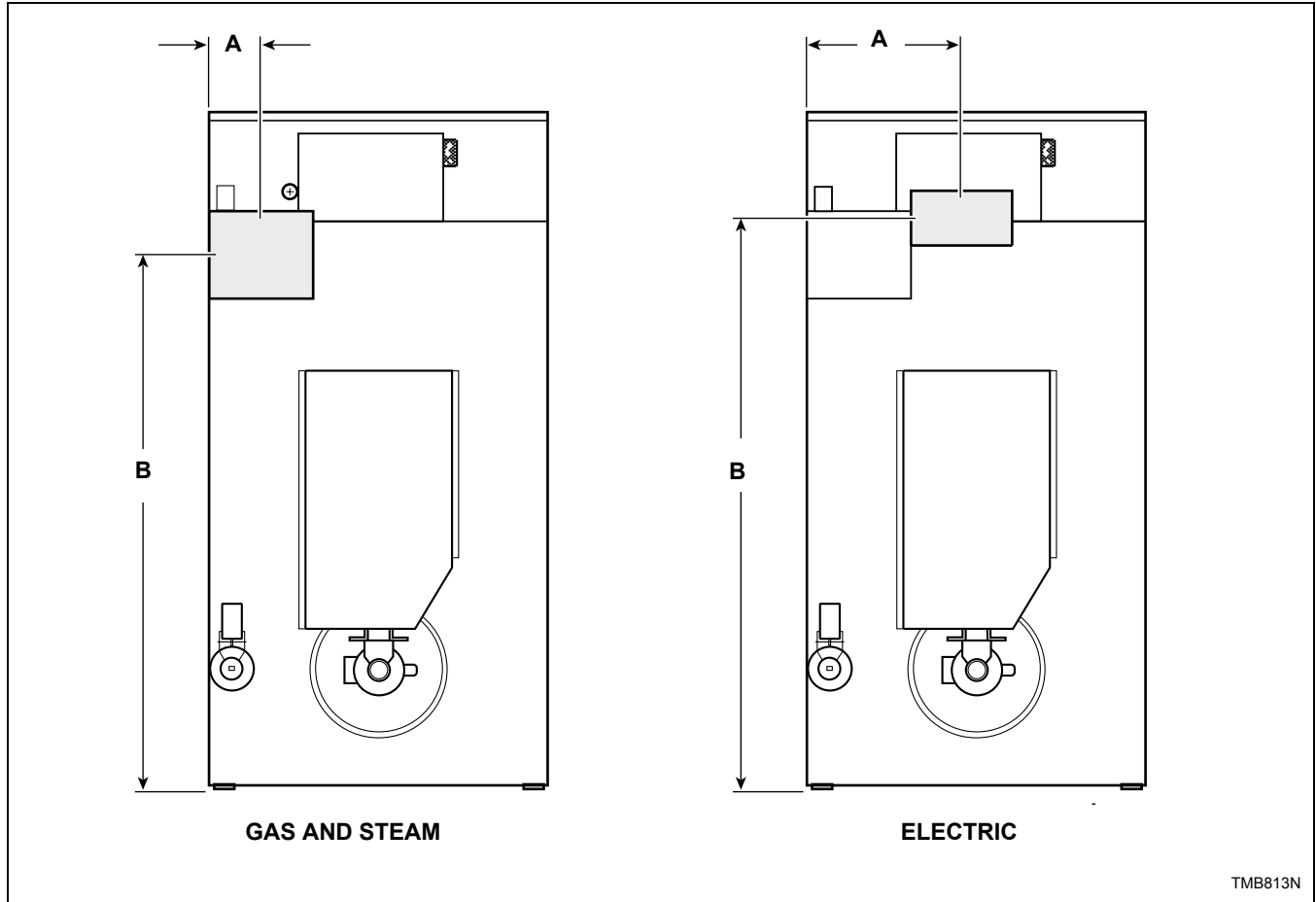

| Models | A | B |
|---------------|---------------------|-----------------------|
| Gas and Steam | 9.5 in. (241 mm) | 63.5 in. (1613 mm) |
| Electric | 19 in. (483 mm) | 64 in. (1626 mm) |

NOTE: These figures are approximate dimensions only.

Specifications and Dimensions

Steam Connection Locations

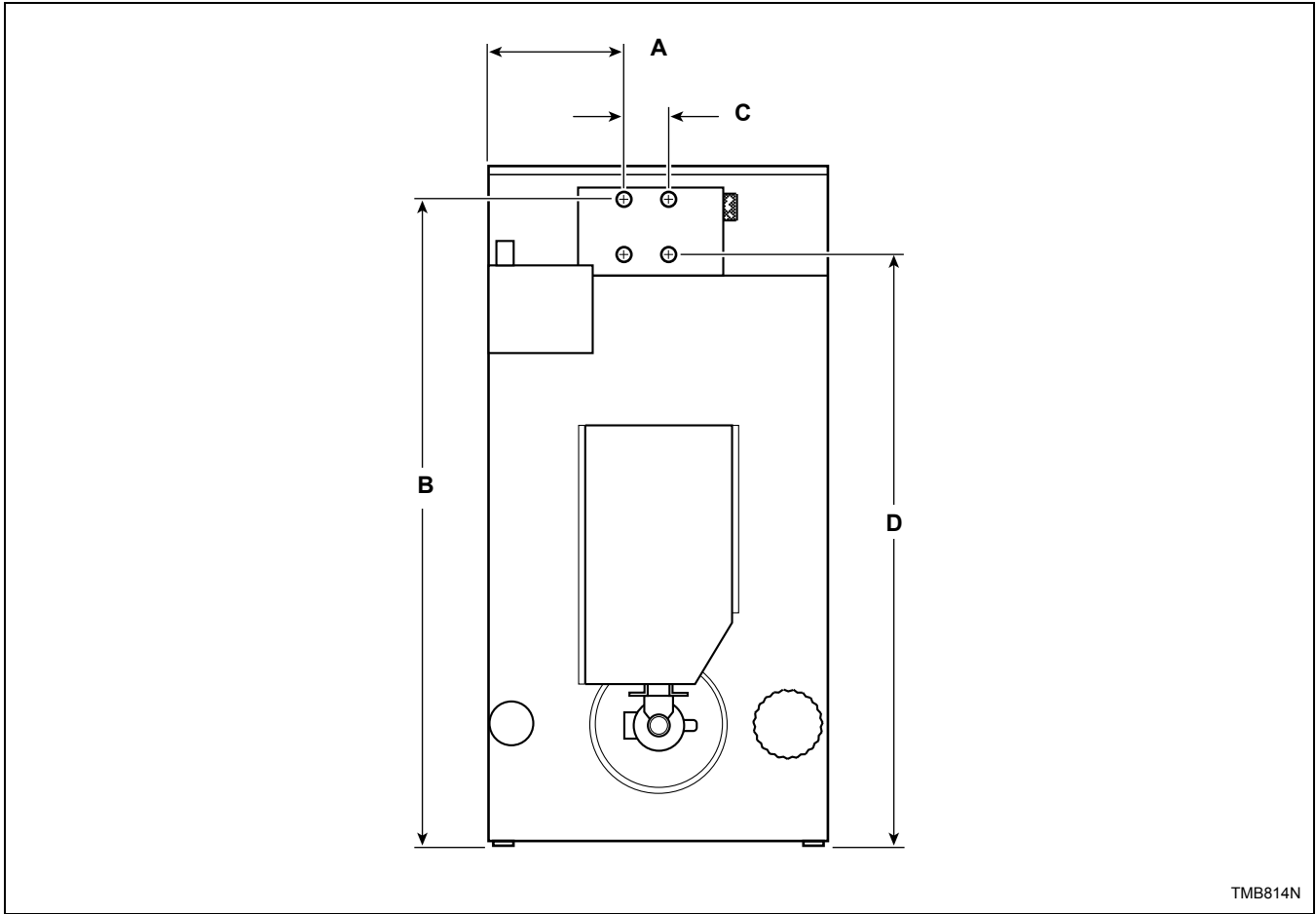

TMB814N

| Models | Diameter | A | B | C | D |
|--------------------|-------------|-----------------------|------------------------|---------------------|------------------------|
| 50/75 Pound | 3/4 in. NPT | 15.25 in. (387 mm) | 72.75 in. (1848 mm) | 7.5 in. (190 mm) | 64.75 in. (1645 mm) |

Installation

Pre-Installation Inspection

Upon delivery, visually inspect the crate, carton and parts for any visible shipping damage. If the crate, carton, or cover is damaged or signs of possible damage are evident, have the carrier note the condition on the shipping papers before the shipping receipt is signed, or advise the carrier of the condition as soon as it is discovered.

Remove the crate and protective cover as soon as possible and check the items listed on the packing list. Advise the carrier of any damaged or missing articles as soon as possible. A written claim should be filed with the carrier immediately if articles are damaged or missing.

IMPORTANT: Remove the shipping tape from the two back draft dampers located in the exhaust outlet.

IMPORTANT: Warranty is void unless tumbler is installed according to instructions in this manual. Installation should comply with minimum specifications and requirements detailed in this manual and applicable local gas fitting regulations, municipal building codes, water supply regulations, electrical wiring regulations, and any other relevant statutory regulations. Due to varied requirements, applicable local codes should be thoroughly understood and all pre-installation work arranged for accordingly.

| Materials Required (Obtain Locally) | |
|-------------------------------------|--|
| All Models | One Single Pole fused disconnect switch or circuit breaker on 1 Phase models. Circuit breaker on 3 Phase models. |
| Gas Models | One gas shut-off valve for gas service line to each tumbler. |
| Steam Models | One steam shut-off valve for steam service line to be connected upstream of solenoid steam valve. Two steam shut-off valves for each condensate return line. Flexible steam hoses with a 125 psig (pounds per square inch gauge) (8.79 kg/sq. cm) working pressure for connecting steam coils. Refer to <i>Figure 23</i> for sizing and connection configurations. Two steam traps for steam coil outlets to condensate return line. Optional – Two vacuum breakers for condensate return lines. |

IMPORTANT: Keep tumbler area clear and free from combustible materials, gasoline and other flammable vapors and liquids.

NOTE: 3 Phase Only – Each tumbler must be connected to its own individual branch circuit breaker, not fuses, to avoid the possibility of “single phasing” and causing premature failure of the motor(s).

Installation

Location Requirements

The tumbler must be installed on a level floor. Floor covering materials such as carpeting or tile should be removed.

To assure compliance, consult local building code requirements. The tumbler must not be installed or stored in area where it will be exposed to water and/or weather.

IMPORTANT: DO NOT block the airflow at the rear of the tumbler with laundry or other articles. Doing so would prevent adequate air supply to the combustion chamber of the tumbler.

A typical tumbler enclosure is shown in *Figure 1*. Note the minimum and maximum dimensions. Local codes and ordinances must be complied with.

| | |
|---|----------------|
|  | WARNING |
| To reduce the risk of serious injury, install lockable door(s) to prevent public access to rear of tumblers. | |
| W055 | |

IMPORTANT: Install tumblers with sufficient clearance for servicing and operation, refer to *Figure 1*.

| | |
|--|----------------|
|  | WARNING |
| To reduce the risk of severe injury, clearance of tumbler cabinet from combustible construction must conform to the minimum clearances. | |
| W056 | |

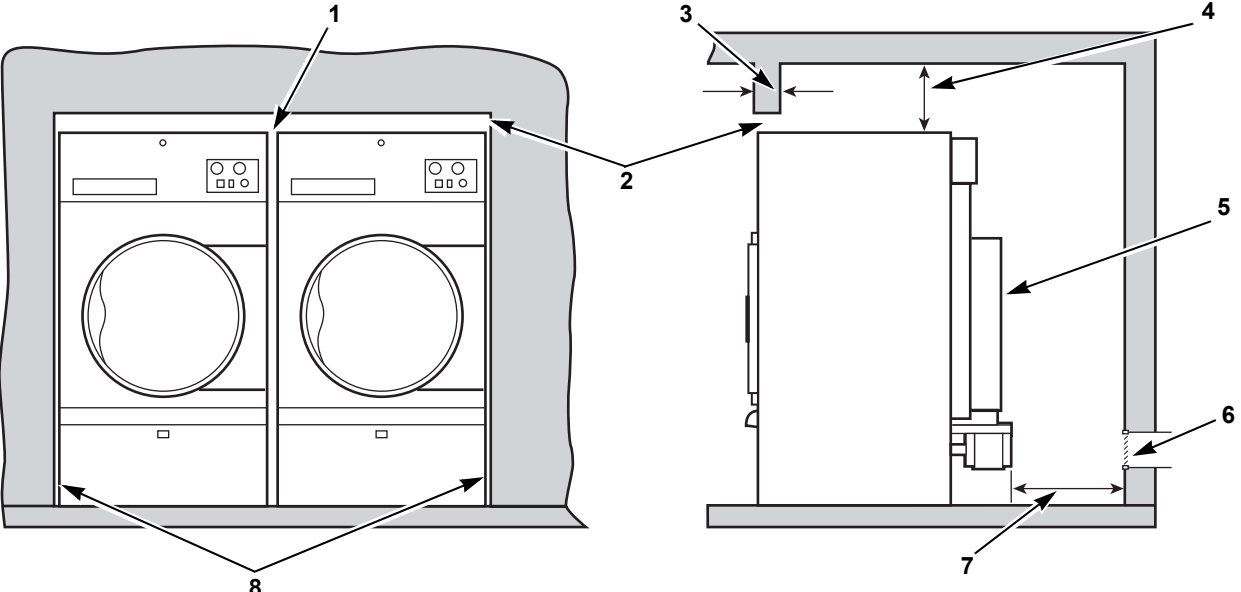

TMB2131N

NOTE: Shaded areas indicate adjacent structure.

- 0.5 in. (13 mm) recommended between machines for removal or installation
- Allow 2-4 in. (51-102 mm) opening at top of machine to aid in removal or installation. A removable trim piece may be used to conceal the opening; zero clearance allowed for trim.
- 4 in. (102 mm) maximum header thickness
- 12 in. (305 mm) minimum clearance permitted for remainder
- Guard
- Provision for make-up air
- 24 in. (610 mm) minimum, 36 in. (914 mm) recommended for maintenance purposes
- 0.25 in. (6 mm) recommended for removal or installation purposes, zero clearance allowed

Figure 1

Position and Level the Tumbler

Remove lint panel door, and unscrew the four shipping bolts (one at each corner). Remove tumbler from skid.

NOTE: Do not throw bolts away – they are the leveling legs.

Remove four nuts from the literature package, and screw one fully on to each leveling leg.

Screw the four leveling legs (bolts) back into the level adjusting fittings from the bottom.

Slide tumbler to its permanent location. Adjust the leveling legs until the unit is level, or no more than 0.125 inch (3.2 mm) higher in the front. Refer to *Figure 2*. Tumbler must not rock. Lock leveling legs with nuts previously installed.

NOTE: The front of the tumbler should be slightly higher than the rear (approximately 0.125 inch, 3.18 mm). This will prevent the clothes, while tumbling, from wearing on the door glass gasket.

IMPORTANT: Keep tumbler as close to floor as possible. The unit must rest firmly on floor so weight of tumbler is evenly distributed.

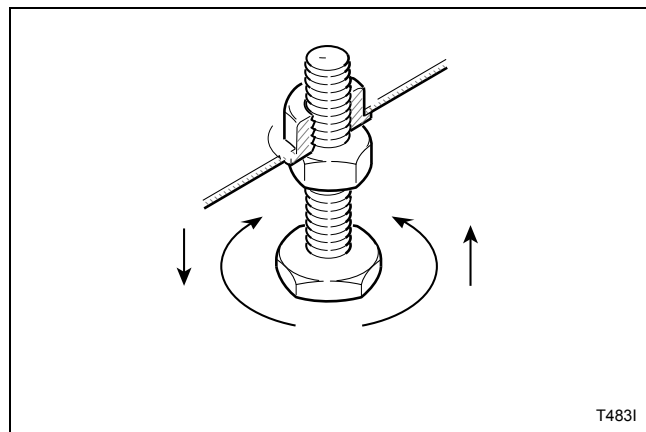

Figure 2

Bolt-On Angle Option

50 Pound Tumblers Only

This option allows the tumbler depth to be reduced to 34 5/16 inches. The tumbler should then fit through a 36 inch door opening (actual 34 1/2 inches).

NOTE: Refer to appropriate troubleshooting manual for details on the following procedures.

1. Remove the loading door, access panel, front panel and lint panel. Refer to *Figure 3*.

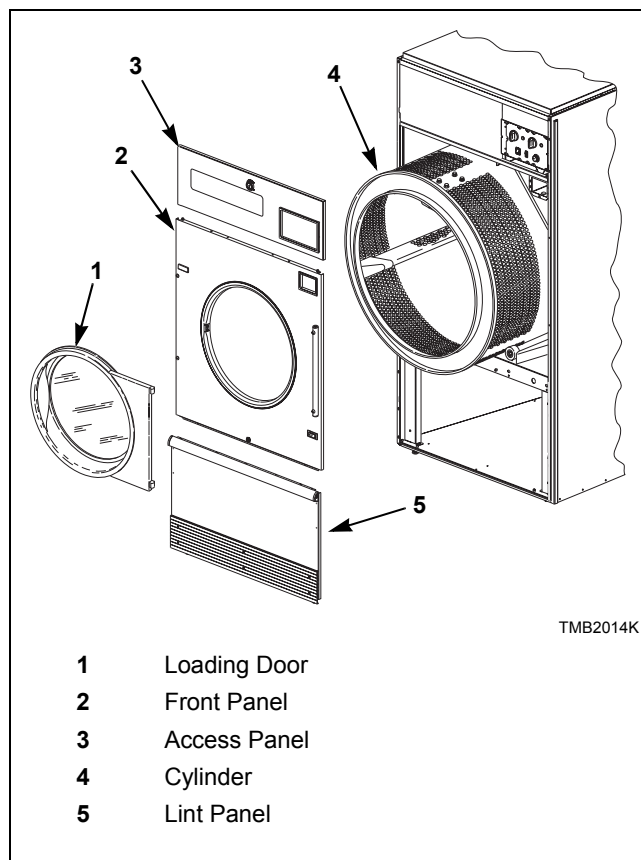

Figure 3

Installation

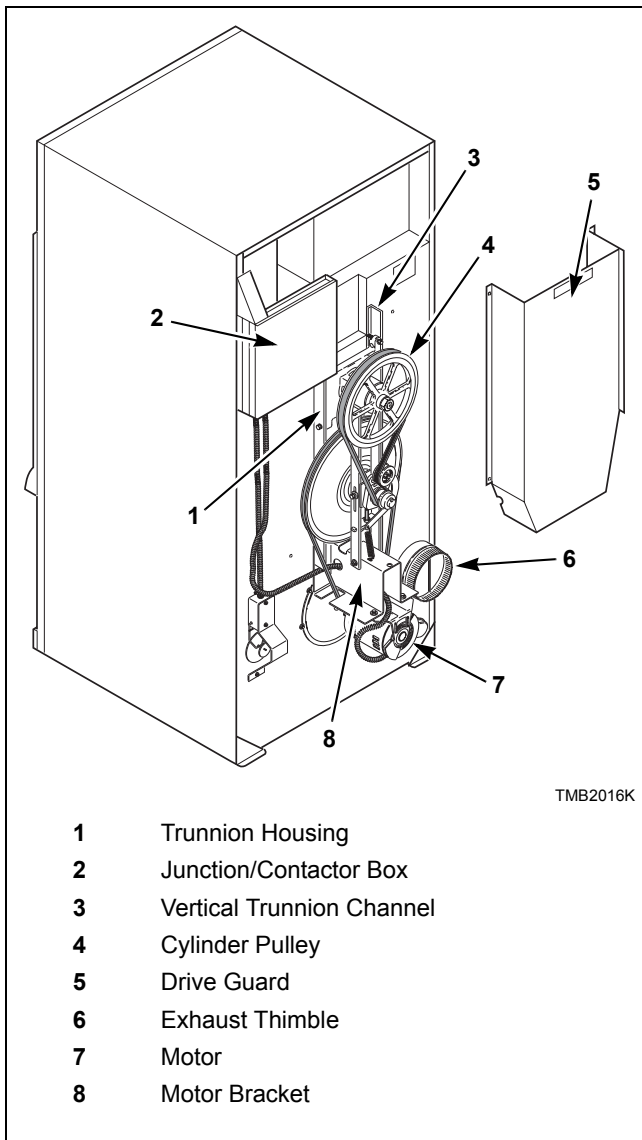

Figure 4

2. Remove the drive guard. Refer to *Figure 4*.
3. Remove the drive belts. Refer to *Figure 4*.
4. Remove the cylinder pulley and shaft key.
5. Pull the cylinder out through the front of the tumbler. Refer to *Figure 3*.
6. To ensure proper cylinder balance for reassembly, mark each channel's original location on cylinder head and number of shims for each channel before removal. Refer to *Figure 5*.
7. Remove the complete idler assembly.
8. Remove the trunnion housing. Refer to *Figure 4*.
9. Disconnect the motor harness(s).

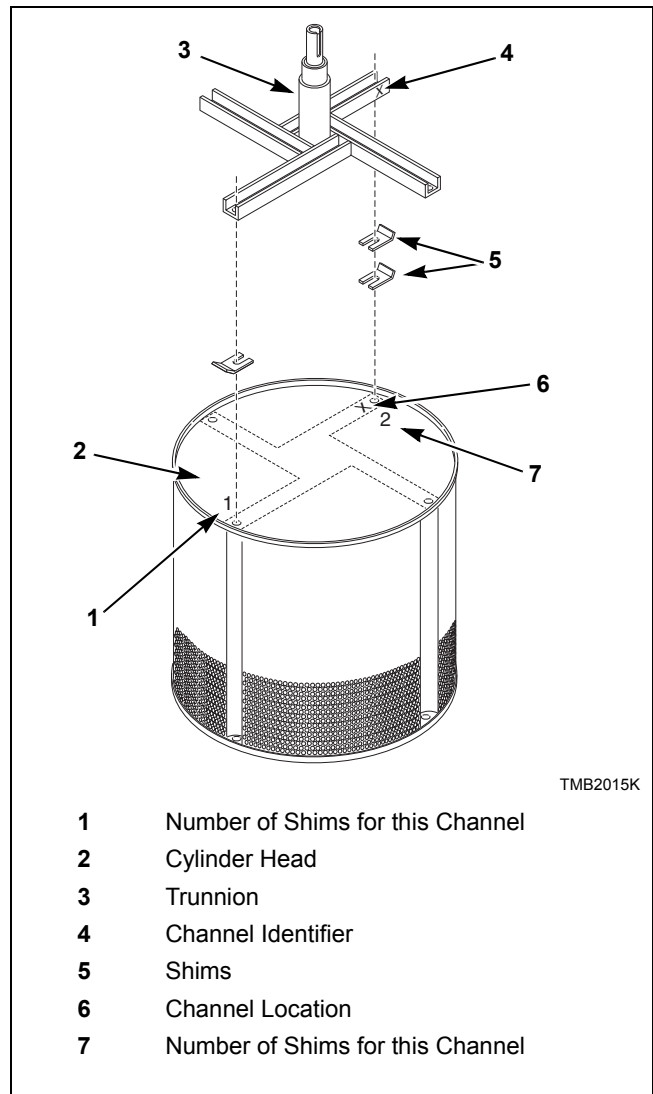



Figure 5

10. Remove the motor(s) and motor bracket(s). Refer to *Figure 4*.
11. Unbolt and remove the two vertical trunnion channels.
12. Remove the junction/contactactor box. Refer to *Figure 4*.
13. Remove the exhaust thimble.
14. The gas supply line may require removal if it extends past the rear panel. If so, disconnect the union located between the gas and shutoff valves and remove the assembly out through the front of the tumbler.
15. Remove the tumbler from the crate base and slide it through the door, sideways.
16. Refer to the appropriate troubleshooting manual, installation manual and wiring diagram to reassemble and install the tumbler correctly.

To Reverse the Loading Door

A, H, S and U models after serial number 0308001307

The tumbler is delivered with a right hinged door, but the door can be changed to a left hinged position.

| | |
|--|----------------|
|  | WARNING |
| <p>To reduce the risk of electric shock, fire, explosion, serious injury or death:</p> <ul style="list-style-type: none"> • Disconnect electric power to the tumbler before servicing. • Close gas shut-off valve to gas tumbler before servicing. • Close steam valve to steam tumbler before servicing. • Never start the tumbler with any guards/panels removed. • Whenever ground wires are removed during servicing, these ground wires must be reconnected to ensure that the tumbler is properly grounded. | |
| W002 | |

1. Disconnect power supply to tumbler.
2. Unlock and remove control panel. Remove two control assembly mounting screws from right side. Swing open control to access upper flange right guide lug assembly. Refer to *Figure 6*.
3. Remove lint panel.

IMPORTANT: Support door and hinge assembly securely to prevent it from dropping once side screws are removed from door hinge lug.

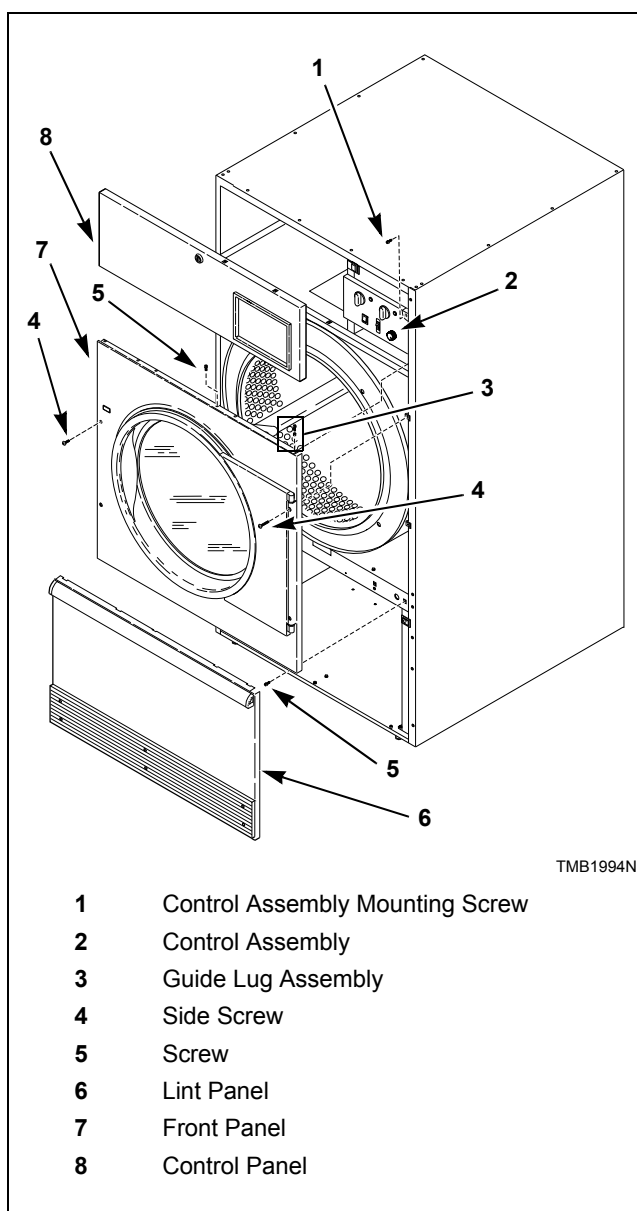

Figure 6

Installation

4. Remove four front panel screws. Refer to *Figure 6*. Keep door hinge cams in place on door hinge lug. Pull lug and door assembly off as one piece. Refer to *Figure 7*.
5. Remove remaining front panel screws, four on the top and four on the bottom. Refer to *Figure 6*. Disconnect door switch harness from switch. Take off front panel. Refer to *Figure 7*.
6. Exchange switch and plug locations. Depress tabs with an adjustable pliers to remove plug and switch from front panel. Reinstall switch, orienting button toward center of machine. Reinstall plug in switch's previous location. Refer to *Figure 7*.

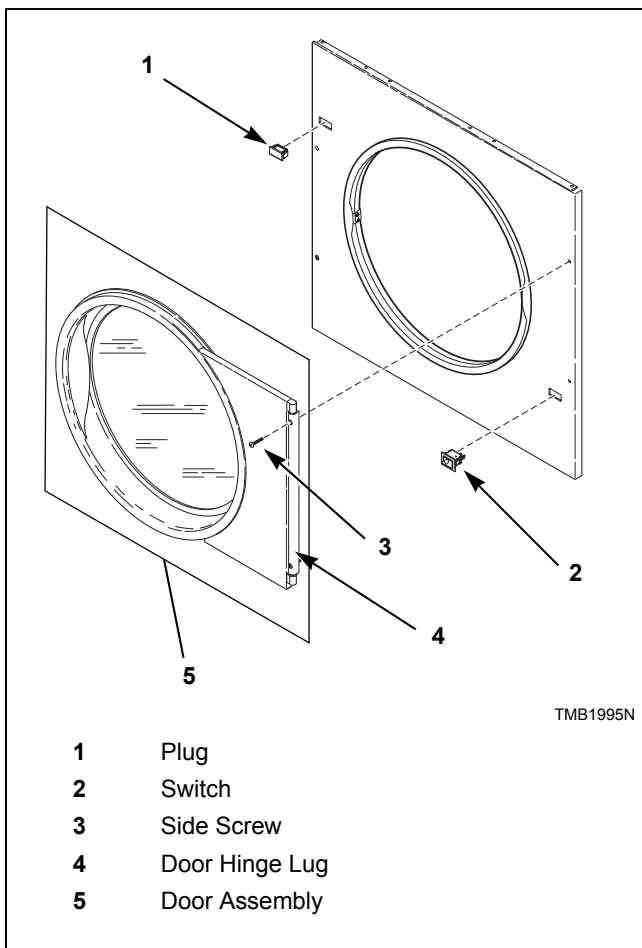

Figure 7

7. Cut wire ties along right side of machine to remove door switch harness from lint panel switch harness bundle. Be careful not to damage harness wires. Refer to *Figure 8*.
8. Reroute door switch harness up through top panel, along underside of front flange, through screw cable clamp, back down through top panel and into upper left quadrant of cylinder enclosure. Refer to *Figure 8*.

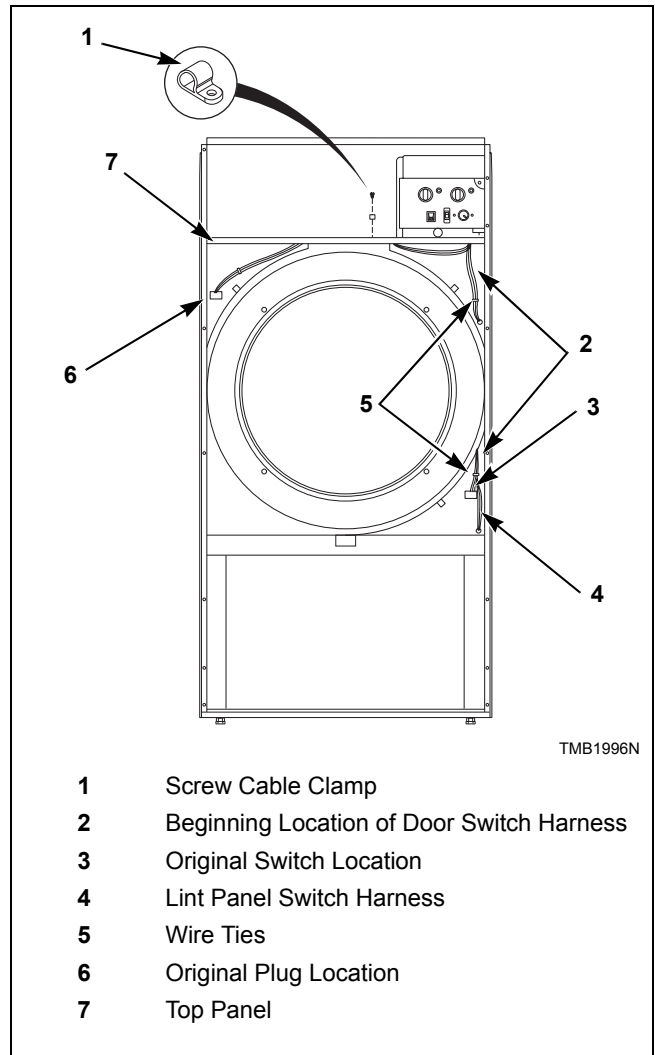

Figure 8

9. Place front panel on machine, loosely attach four bottom screws. Connect door switch harness to switch in new location. Install door assembly and four front panel side screws loosely. Refer to *Figure 9*.
10. Check lint panel fit, adjusting front panel up or down as required. Tighten four front panel side screws to maintain position of front panel for proper lint panel clearance.
11. Remove lint panel. Fully tighten bottom screws on front panel.
12. Reinstall top screws and guide lugs.
13. Adjust door catch if necessary to allow 7 – 15 pounds pull (0.48 – 1.03 bar) at center of handle.
14. Reinstall control assembly using mounting screws.
15. Reinstall control panel and lint panel.

IMPORTANT: Restore power to tumbler and test for proper operation of loading door switch. Tumbler should not start with door open; an operating tumbler should stop when door is opened.

NOTE: If machine is converted back to right hand hinge operation, the door switch harness must be rerouted and rebundled with the lint panel switch harness. Wire ties must be used to secure harnesses. Wire ties (Part No. 55881) can be ordered from RSPC.

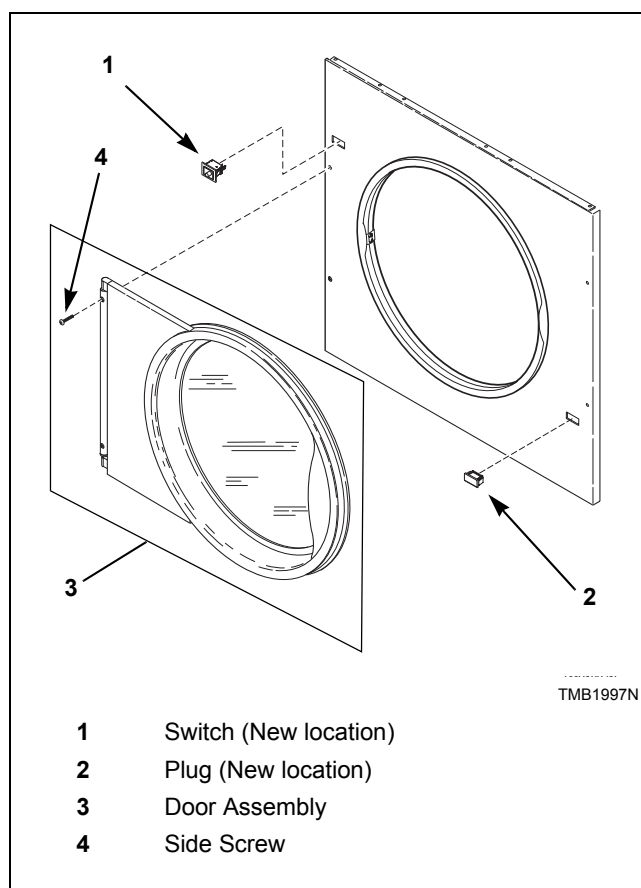

Figure 9

Installation

Before Placing Tumbler into Service

1. Remove or open all panels and check accessible bolts, nuts, screws, terminals and fittings for tightness.
2. Check belt tension and adjust if necessary. Refer to *Adjustments* section.
3. Replace all panels and guards.
4. Turn on electrical supply to tumbler.
5. Open the supply valve for gas or steam heated tumblers.
6. After performing the previous checks, start the tumbler by pressing START. (Refer to the *Operating Manual* for detailed instructions.) Release the start button and open the loading door. The cylinder should stop rotating within seven seconds after the door is opened a maximum of 2 inches (51 mm). If it does not, adjust the loading door switch. Refer to *Adjustments* section.
7. **Gas Tumblers:** Start the tumbler and check the burner flame. Adjust the air inlet shutter as required. Refer to *Adjustments* section.

IMPORTANT: The electronic ignition system will attempt to light the gas by sparking for the “trial for ignition” period. If gas does not ignite within this period, the ignition control will go into a safety lockout and the valve will no longer open until the control is reset. It may be necessary to retry several times to bleed air from the gas lines. To reset, open and close the loading door and restart tumbler.

| | Prepurge Time (seconds) | Trial for Ignition (seconds) | Reset Lockout Condition By: |
|-------------------|-------------------------|------------------------------|--|
| Australia | 18 | 5 | Open loading door |
| CE | 18 | 10 | Press reset button behind front access panel |
| All Others | 1 – 3 | 10 | Open loading door |

If lockout condition persists, check that the manual gas shut-off valve is in the ON position and that the gas service is properly connected. If condition still persists, remove tumbler from service.

8. Load the cylinder with a full load of clean rags and run to remove oil or dirt from cylinder.
9. Check the airflow switch operation refer to *Adjustments* section. The heating systems should shut off when the lint panel is opened a maximum of 1.5 inches (38 mm).

The airflow switch operation may be affected by shipping tape still in place, lack of make-up air, or an obstruction in the exhaust duct. These should be checked and the required corrective action taken before attempting to adjust the airflow switch. To adjust the airflow switch, refer to *Adjustments* section.



WARNING

Do not operate tumbler if airflow switch is faulty. An explosive gas mixture could collect in tumbler if airflow switch does not operate properly.

W407

10. Wipe out the cylinder using an all-purpose cleaner or detergent and water solution. Refer to *Figure 10*.

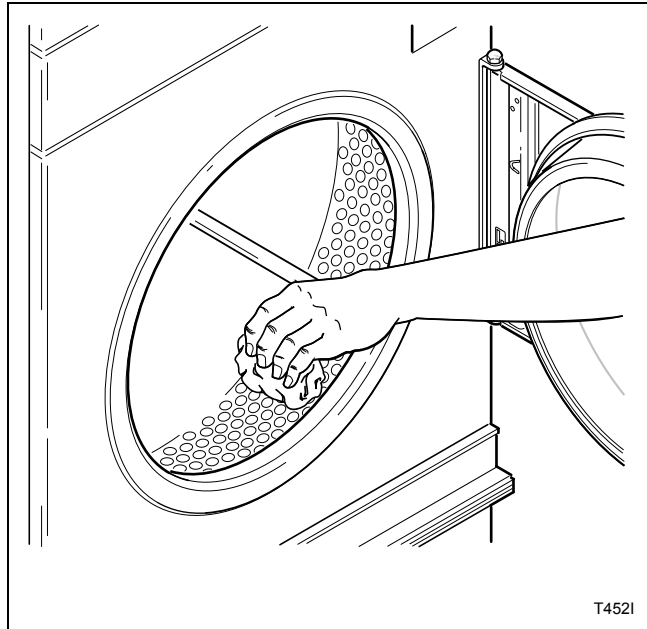

Figure 10

If the tumbler does not meet ANY of the listed requirements, remove tumbler from use. Refer to *Removing Tumbler from Service* section.

Required for CE Models Only

Once machine is installed, please be sure to complete the following items:

- Review and verify machine operation with customer.
- Leave all literature and a signed Declaration of Conformity with customer.
- Review machine warranty information with customer.
- Apply warning sticker on front panel of machine, in language appropriate to country of sale (included in literature packet).

Installing CE Gas Drying Tumblers

| | |
|--|----------------|
|  | WARNING |
| <p>To reduce the risk of electric shock, fire, explosion, serious injury or death:</p> <ul style="list-style-type: none"> • Disconnect electric power to the tumbler before servicing. • Close gas shut-off valve to gas tumbler before servicing. • Close steam valve to steam tumbler before servicing. • Never start the tumbler with any guards/panels removed. • Whenever ground wires are removed during servicing, these ground wires must be reconnected to ensure that the tumbler is properly grounded. | |
| W002 | |

General Information

This information is to be used when installing gas tumblers in countries and/or on gases different than the machine's factory configuration. Tumblers are supplied from the factory for operation on Natural Gas 1000 Btu/cu ft. (8914 kcal/m³), or L.P. Gas 2500 Btu/cu ft. (22,250 kcal/m³), in the countries of GB/IE/PT/ES/IT/GR/LU/CH. To install machines in any other country, or on any other gas, requires some level of modification.

Machines are built in two different configurations:

- **Natural Gas** – regulated/governor
- **Liquefied Petroleum (L.P.) Gas** – not regulated/no governor

Machines configured for Natural Gas (regulator/governor) may be converted to L.P. Gas (not regulated/no governor) with block-open kit, Part No. M400763.

Serial plates supplied from the factory are configured for GB/IE/PT/ES/IT/GR/LU/CH. These instructions pertain to the situations when the country of use or gas supply is different than that on the serial plate.

Table 1 describes the different gases that are available in different CE countries, and how the machines need to be configured to operate with those gases. In the CE, there are Natural Gas configurations that do not allow for machine regulation and L.P. Gas configurations that must be regulated. For L.P. Gas, third family B/P at 50 mbar, order Regulated Natural Gas machines and convert according to *Table 1*.

Installation

| Country Code | Gas Type | Group | Supply Pressure, mbar | Burner Orifice Pressure, mbar | Capacity/ Model | Diameter, mm | Quantity | Burner Orifice Part No. |
|--------------------------------------|-------------|-------|-----------------------|-------------------------------|-----------------|--------------|----------|-------------------------|
| DK/NO/SE/FI/CZ/EE/LV/LT/SI/SK | Natural Gas | H | 20 | 8.9 | 050 075 | 3.7 3.6 | 2 3 | M401000 M401014 |
| | L.P. Gas | B/P | 30 | No Governor | 050 075 | 2.1 2.0 | 2 3 | M401003 M400999 |
| DE** | Natural Gas | E | 20 | 8.9 | 050 075 | 3.7 3.6 | 2 3 | M401000 M401014 |
| | | LL | 25 | 12.6 | 050 075 | 3.7 3.6 | 2 3 | M401000 M401014 |
| | L.P. Gas | B/P | 30 | No Governor | 050 075 | 2.1 2.0 | 2 3 | M401003 M400999 |
| | | B/P | 50 | 28.5 | 050 075 | 2.1 2.0 | 2 3 | M401003 M400999 |
| NL | Natural Gas | L | 25 | 12.6 | 050 075 | 3.7 3.6 | 2 3 | M401000 M401014 |
| | L.P. Gas | B/P | 30 | No Governor | 050 075 | 2.1 2.0 | 2 3 | M401003 M400999 |
| BE/FR* | Natural Gas | E+ | 20/25 | No Governor | 050 075 | 3.0 2.9 | 2 3 | M401017 N/A |
| | L.P. Gas | + | 28/37 | No Governor | 050 075 | 2.1 2.0 | 2 3 | M401003 M400999 |
| GB/IE/PT/ES/IT/GR/LU/CH | Natural Gas | H | 20 | 8.9 | 050 075 | 3.7 3.6 | 2 3 | M401000 M401014 |
| | L.P. Gas | + | 28/37 | No Governor | 050 075 | 2.1 2.0 | 2 3 | M401003 M400999 |
| AT** | Natural Gas | H | 20 | 8.9 | 050 075 | 3.7 3.6 | 2 3 | M401000 M401014 |
| | L.P. Gas | B/P | 50 | 28.5 | 050 075 | 2.1 2.0 | 2 3 | M401003 M400999 |
| CY/IS/MT | L.P. Gas | B/P | 30 | No Governor | 050 075 | 2.1 2.0 | 2 3 | M401003 M400999 |
| HU | Natural Gas | H | 25 | 8.9 | 050 075 | 3.7 3.6 | 2 3 | M401000 M401014 |
| | L.P. Gas | B/P | 30 | No Governor | 050 075 | 2.1 2.0 | 2 3 | M401003 M400999 |
| PL | Natural Gas | H | 20 | 8.9 | 050 075 | 3.7 3.6 | 2 3 | M401000 M401014 |
| | L.P. Gas | 3P | 37 | No Governor | 050 075 | 2.1 2.0 | 2 3 | M401003 M400999 |

Table 1

Burner orifice information at 0-2000 feet (0-600 meters) altitude.

N/A = Part no longer available.

* For Natural Gas, Group E+ applications, convert using L.P. Gas model and replace burner orifice(s).

** For L.P. Gas, Group B/P with 50 mbar supply pressure, convert using Natural Gas model, M411334 regulator spring kit and burner orifice(s).

Basic Configuration

1. Determine the necessary conversion operations to convert from the factory-supplied configuration to the desired configuration.
2. Perform the conversions required so the machine is properly configured for the desired country and gas (refer to *Specific Conversion Procedures* section):
 - How to Convert Gas Valve from Regulated to Unregulated

NOTE: Conversion from regulated to unregulated is only needed when regulated tumblers were ordered, but unregulated tumblers were needed.

- How to Change Burner Orifice Size
 - How to Adjust Gas Valve Governor/Regulator
3. If applicable, peel off the appropriate country sticker (included with machine) and apply it to the serial plate over the existing country information.
 4. If applicable, peel off the appropriate conversion sticker (included with machine) and apply it to the serial plate over the “ADJUSTED FOR _____ GAS: _____” information.
 5. Commission tumbler for use.

| | |
|---|----------------|
|  | WARNING |
| <p>When converting the tumbler to a different gas or pressure, first verify that the supply inlet pressure is equipped with a pressure regulator (located ahead of the tumbler) that will maintain the gas supply at the inlet pressure specified.</p> | |
| W430 | |

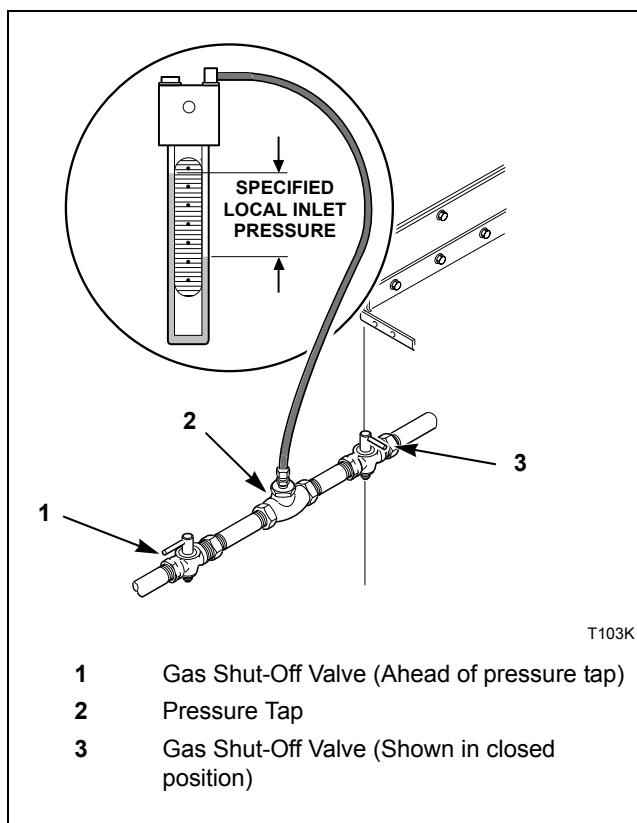

Figure 11

Specific Conversion Procedures

How to Convert Gas Valve from Regulated to Unregulated

NOTE: Conversion from regulated to unregulated is only needed when regulated tumblers were ordered, but unregulated tumblers were needed.

Johnson G96 Gas Valve:

- a. Disconnect electrical power from tumbler. Close gas shut-off valve to tumbler. Refer to *Figure 11*.
- b. Follow instructions in Conversion Kit, Part No. M400763 (Johnson Part No. Y71AA-5C).

NOTE: This kit does not contain any burner orifices.

- c. Replace burner orifice(s) as per *Table 1*.
- d. Commission tumbler for use.

Installation

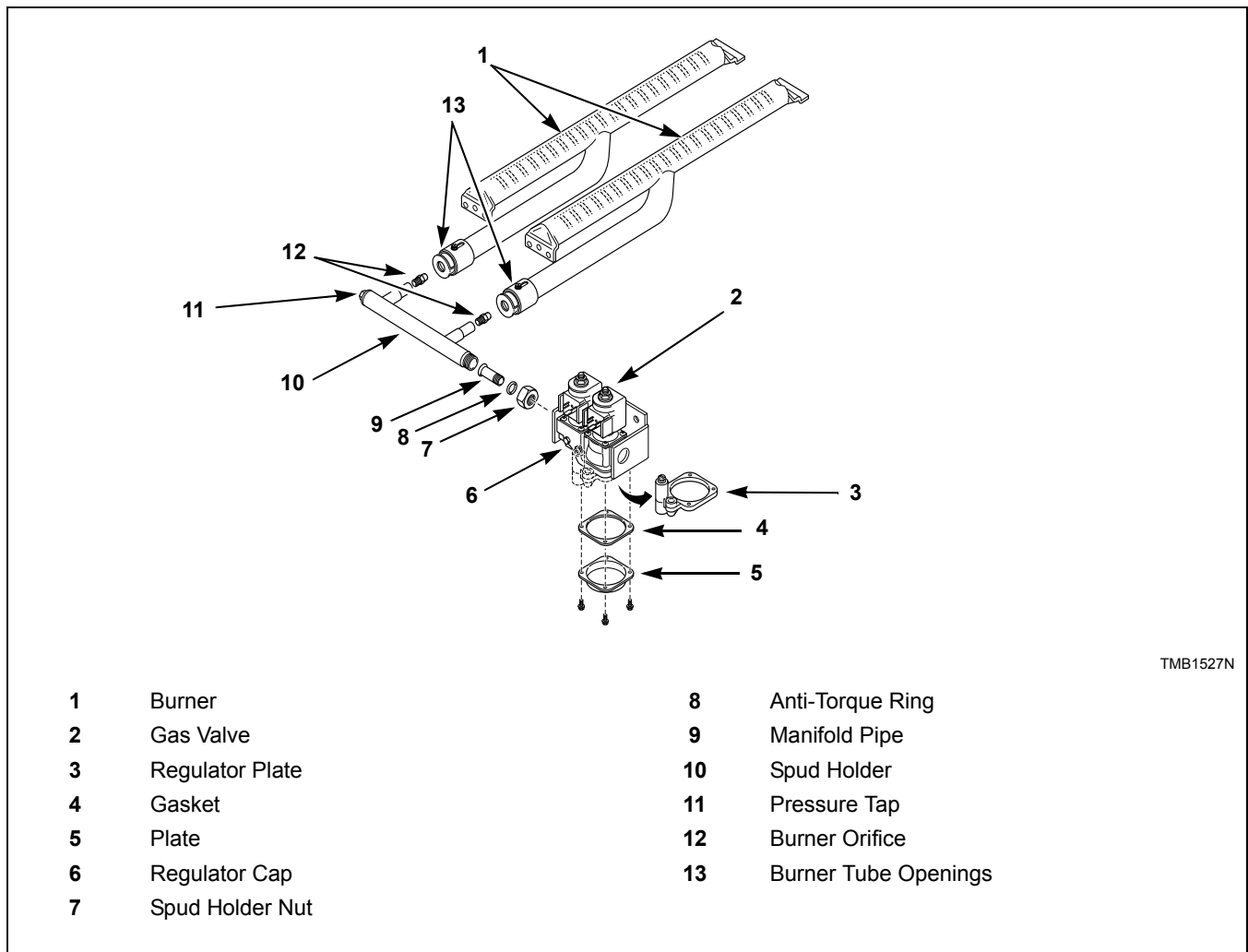

Figure 12

How to Change Burner Orifice Size

1. Disconnect electrical power from tumbler. Close gas shut-off valve to tumbler. Refer to *Figure 11*.
2. Remove spud holder.

Johnson G96 Gas Valve – Unscrew spud holder nut near gas valve. Remove the burner orifice(s) from spud holder. Refer to *Figure 12*.

3. Install the new, correct burner orifice(s). Refer to *Figure 13* and *Table 1*. Torque each to 9 – 10 Nm.
4. Reinstall spud holder assembly to gas valve, making certain burner orifice(s) are in line with burner tube opening. Refer to *Figure 13*.
5. Commission tumbler for use.

NOTE: Blank burner orifices are Part No. M400995.

How to Adjust Gas Valve Governor/Regulator

1. Check gas burner orifice (manifold) pressure as follows. Refer to *Figure 12*.
2. Remove screw plug from pressure tap.
3. Connect a “U”-tube manometer (or similar pressure gauge) to the burner orifice (manifold) pressure tap.
4. Start tumbler and note pressure once flame is burning. Remove regulator cap and adjust regulator screw until the burner orifice pressure per applicable table is achieved. Replace regulator cap. Refer to *Figure 12*.
5. Commission tumbler for use.

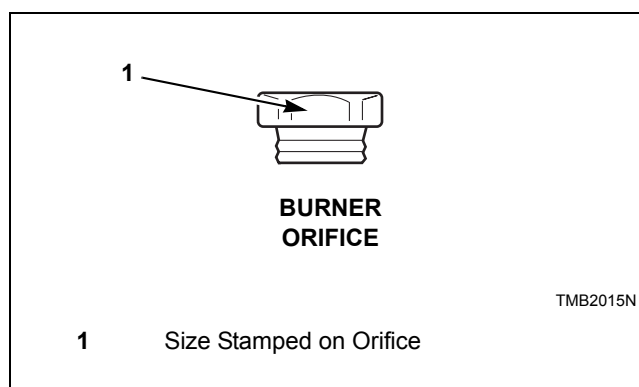



Figure 13

Exhaust Requirements

| | |
|--|----------------|
|  | WARNING |
| <p>A drying tumbler produces combustible lint. To reduce the risk of fire, the tumbler must be exhausted to the outdoors.</p> <p style="text-align: right;">W057</p> | |
| <p>To reduce the risk of fire and accumulation of combustible gases, DO NOT exhaust tumbler air into a window well, gas vent, chimney or enclosed, unventilated area such as an attic wall, ceiling, crawl space under a building, or concealed space of a building.</p> <p style="text-align: right;">W059</p> | |

Layout

Whenever possible, install tumblers along an outside wall where duct length can be kept to a minimum, and make-up air can be easily accessed. Construction must not block the airflow at the rear of the tumbler. Doing so would prevent adequate air supply to the tumbler combustion chamber.

Make-Up Air

A tumbler is forced air exhausted and requires provisions for make-up air to replace air exhausted by tumbler.

IMPORTANT: Do not obstruct flow of combustion and ventilation air.

| Required Make-Up Air Opening (to the outside) for Each Tumbler | |
|---|---|
| Model | Opening |
| 50 Pound | 144 in ² (928 cm ²) |
| 75 Pound | 195 in ² (1258 cm ²) |
| F75 | 250 in ² (1613 cm ²) |

Make-up air openings with louvers will restrict airflow. The opening must be increased to compensate for area taken up by louvers.

Make-up air openings in rooms containing tumbler(s) and/or gas fired hot water heater or other gravity vented appliances must be increased sufficiently to prevent downdrafts in any of the vents when all tumblers are in operation. Do not locate gravity vented appliances between tumbler(s) and make-up air openings. If it is necessary to duct make-up air to tumbler(s), increase area of duct work by 25% to compensate for restrictions in air movement.

Venting

| | |
|---|----------------|
|  | WARNING |
| <p>To reduce the risk of fire due to increased static pressure, we do not recommend installation of in-line secondary lint filters or lint collectors. If secondary systems are mandated, frequently clean the system to assure safe operation.</p> <p style="text-align: right;">W749</p> | |

IMPORTANT: Installing in-line filters or lint collectors will cause increased static pressure. Failure to maintain the secondary lint system will decrease tumbler efficiency and may void machine warranty.

For maximum efficiency and minimum lint accumulation, tumbler air must be exhausted to the outdoors by the shortest possible route.

Proper sized exhaust ducts are essential for proper operation. All elbows should be sweep type. Exhaust ducts must be assembled so the interior surfaces are smooth, so the joints do not permit the accumulation of lint. DO NOT use plastic or thin foil ducts – rigid metal ducts are recommended. Use exhaust ducts made of sheet metal or other noncombustible material. DO NOT use sheet metal screws or fasteners on exhaust pipe joints which extend into the duct and catch lint. Use duct tape or pop-rivets on all seams and joints.

Verify that old ducts are thoroughly cleaned out before installing new tumbler(s).

| | |
|--|----------------|
|  | WARNING |
| <p>Improperly sized or assembled ductwork causes excess back pressure which results in slow drying, lint collecting in the duct, lint blowing back into the room, and increased fire hazard.</p> <p style="text-align: right;">W355</p> | |

NOTE: Exhaust ducts must be constructed of sheet metal or other noncombustible material. Such ducts must be equivalent in strength and corrosion resistance to ducts made of galvanized sheet steel not less than 0.0195 inches (0.495 mm) thick.

Where the exhaust duct pierces a combustible wall or ceiling, the opening must be sized per local codes. The space around the duct may be sealed with noncombustible material. Refer to *Figure 15*.

IMPORTANT: For best performance provide an individual exhaust duct for each tumbler. Do not install a hot water heater in a room containing tumblers. It is better to have the water heater in a separate room with a separate air inlet.

Individual Venting

For maximum efficiency and performance, it is preferred to exhaust tumbler(s) individually to the outdoors.

IMPORTANT: At no point may the cross sectional area of installed venting be less than the cross sectional area of the exhaust outlet of the tumbler.

The exhaust duct must be designed so the static back pressure measured 12 inches (305 mm) from the exhaust outlet does not exceed the maximum allowable pressure specified on the installation sticker on the rear of the tumbler.

NOTE: Static back pressure must be measured with the tumbler running.

The maximum allowable length venting is 14 feet (4.3 m) and two 90° elbows or equivalent. If the equivalent length of a duct required for an installation exceeds the maximum allowable equivalent length, the diameter of a round duct must be increased by 10% for each additional 20 feet (6.1 m). Cross section area of a rectangular duct must be increased by 20% for each additional 20 feet (6.1 m). Refer to *Table 2* to determine equivalent venting.

NOTE: The maximum length of a flexible metal duct must not exceed 7.87 ft. (2.4 m) as required to meet UL2158, clause 7.3.2A.

| Duct Diameter | Equivalent Length of Rigid Straight Duct |
|-----------------|--|
| 8 in. (203 mm) | One 90° elbow = 9.3 ft. (2.83 m) |
| 10 in. (254 mm) | One 90° elbow = 11.6 ft. (3.5 m) |
| 12 in. (305 mm) | One 90° elbow = 14 ft. (4.3 m) |
| 14 in. (356 mm) | One 90° elbow = 16 ft. (4.9 m) |
| 16 in. (406 mm) | One 90° elbow = 18.7 ft. (5.7 m) |
| 18 in. (457 mm) | One 90° elbow = 21 ft. (6.4 m) |

Equivalent Length (feet) = 1.17 x Duct Diameter (inches)

Table 2

Example: A 12 inch (305 mm) diameter duct’s equivalent length of 14 feet (4.3 m) of duct and two 90° elbows is:

Equivalent Length = 14 feet + (2) 90° elbows
 = 14 feet + 14 feet + 14 feet
 = 42 feet (12.8 m)

With the tumbler in operation, airflow at any point in the duct should be at least 1200 feet per minute (366 m/min.) to ensure that lint remains airborne. If 1200 feet per minute cannot be maintained, schedule monthly inspections and cleaning of the ductwork.

Manifold Venting

While it is preferable to exhaust tumblers individually to the outdoors, a main collector duct may be used if it is sized according to *Figure 16* and *Figure 17*. This illustration indicates minimum diameters, and should be increased if the collector length exceeds 14 feet (4.3 m) and two 90° elbows. The diameter of a round duct must be increased by 10% for each additional 20 feet (6.1 m). Cross sectional area of a rectangular or square duct must be increased 20% for each additional 20 feet (6.1 m). Refer to *Table 3* and *Table 4* to determine equivalent ducting sizing. The collector duct may be rectangular or square in cross section, as long as the area is not reduced. Provisions **MUST** be made for lint removal and cleaning of the collector duct.

The vent collector system must be designed so the static back pressure measured 12 inches (305 mm) from the exhaust outlet does not exceed the maximum allowable pressure of 0.5 W.C.I. (1.3 mbar) as specified on the installation sticker on the rear of tumbler. Static back pressure must be measured with all tumblers vented into the collector operating.

NOTE: Never connect a tumbler duct at a 90° angle to the collector duct. Refer to *Figure 14*. Doing so will cause excessive back pressure, resulting in poor performance. Never connect two tumbler exhaust ducts directly across from each other at the point of entry to the collector duct.

With the tumbler in operation, airflow at any point in the duct should be at least 1200 feet per minute (366 m/min.) to ensure that lint remains airborne. If 1200 feet per minute cannot be maintained, schedule monthly inspections and cleaning of the ductwork.

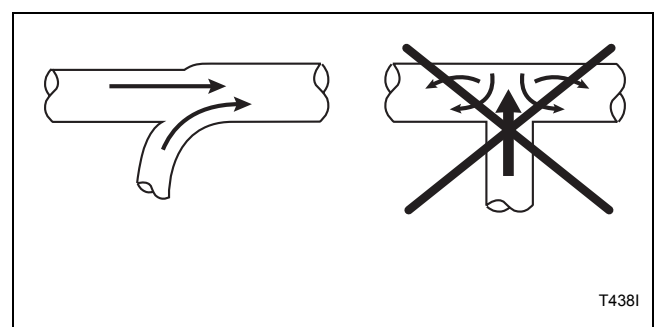

Figure 14

T438I

Exhaust Requirements

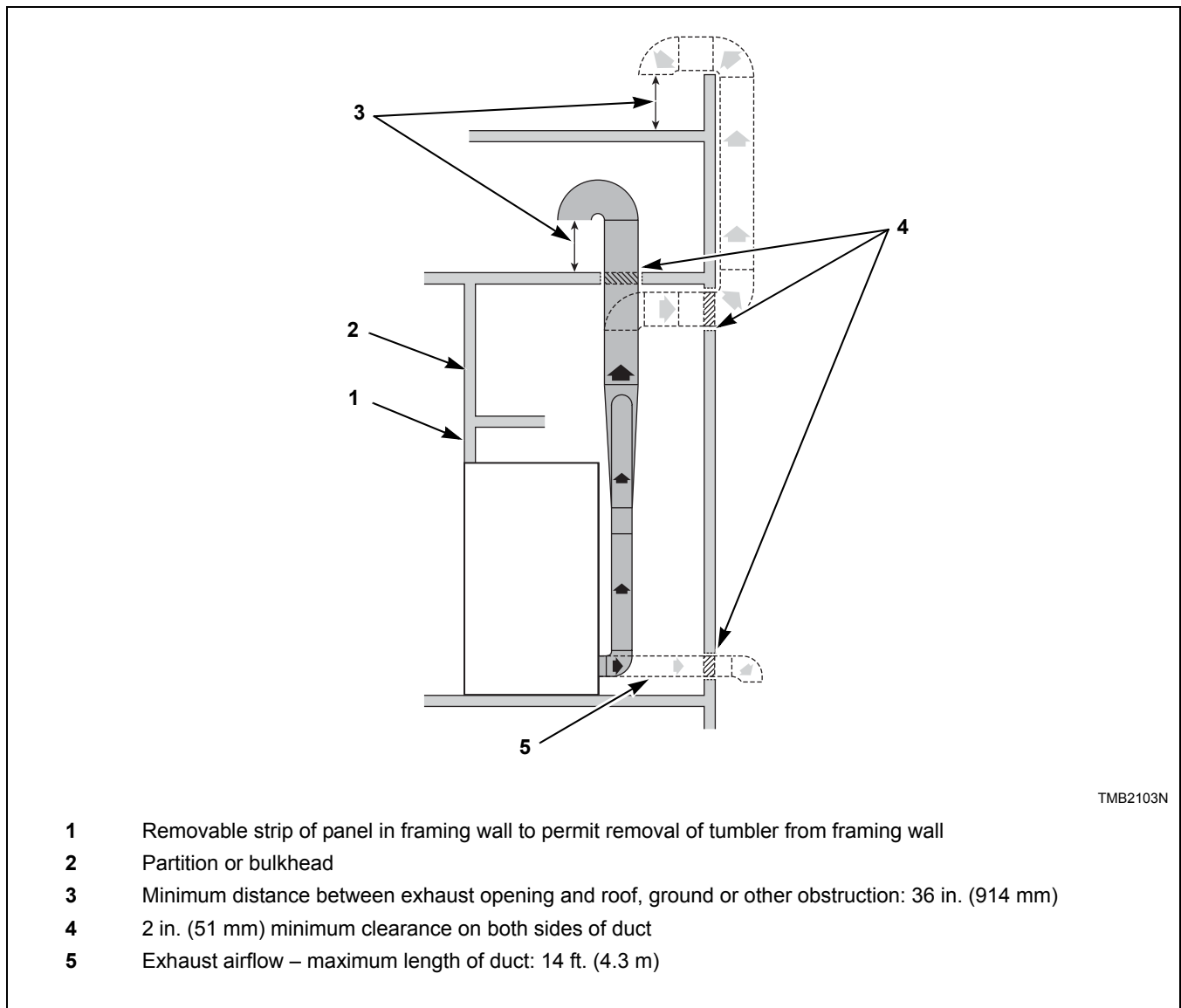

Figure 15

NOTE: Do not install wire mesh or screen in exhaust duct opening to avoid lint build-up or impacting proper discharge of air from tumblers.

NOTE: Where exhaust duct pierces a combustible wall or ceiling, the opening must be sized per local codes.

NOTE: Inside of duct must be smooth. Do not use sheet metal screws to join sections.

Consult your local building code for regulations which may also apply.

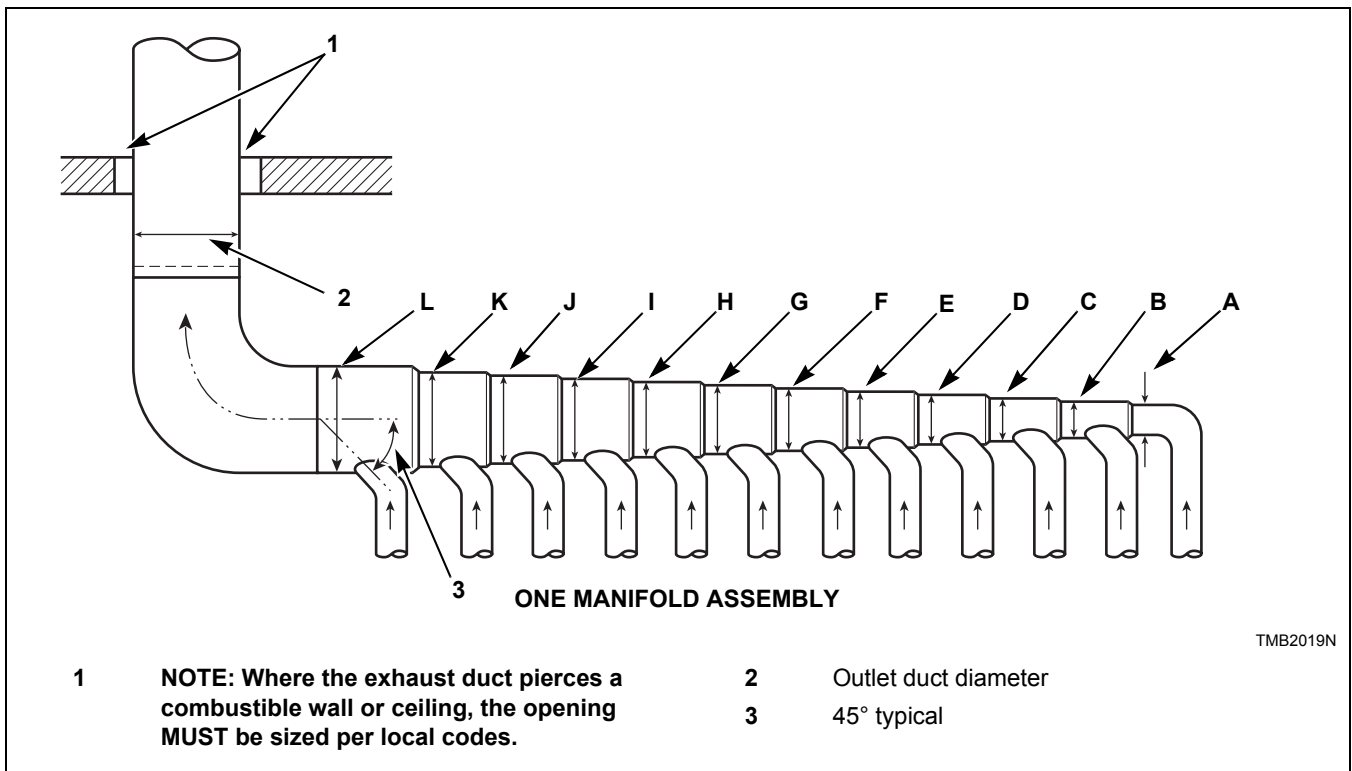

Figure 16

| Duct Station | 50/75 Pound | F75 |
|--------------|---------------------|----------------------|
| | 8 in. (203 mm) Duct | 10 in. (254 mm) Duct |
| A | 8 in. (203 mm) | 10 in. (254 mm) |
| B | 12 in. (305 mm) | 15 in. (381 mm) |
| C | 15 in. (381 mm) | 18 in. (457 mm) |
| D | 17 in. (432 mm) | 21 in. (533 mm) |
| E | 19 in. (483 mm) | 24 in. (610 mm) |
| F | 21 in. (533 mm) | 26 in. (660 mm) |
| G | 23 in. (584 mm) | 28 in. (711 mm) |
| H | 25 in. (635 mm) | 30 in. (762 mm) |
| I | 26 in. (660 mm) | 32 in. (813 mm) |
| J | 27 in. (686 mm) | 33 in. (838 mm) |
| K | 29 in. (737 mm) | 35 in. (889 mm) |
| L | 30 in. (762 mm) | 36 in. (914 mm) |

Table 3

Exhaust Requirements

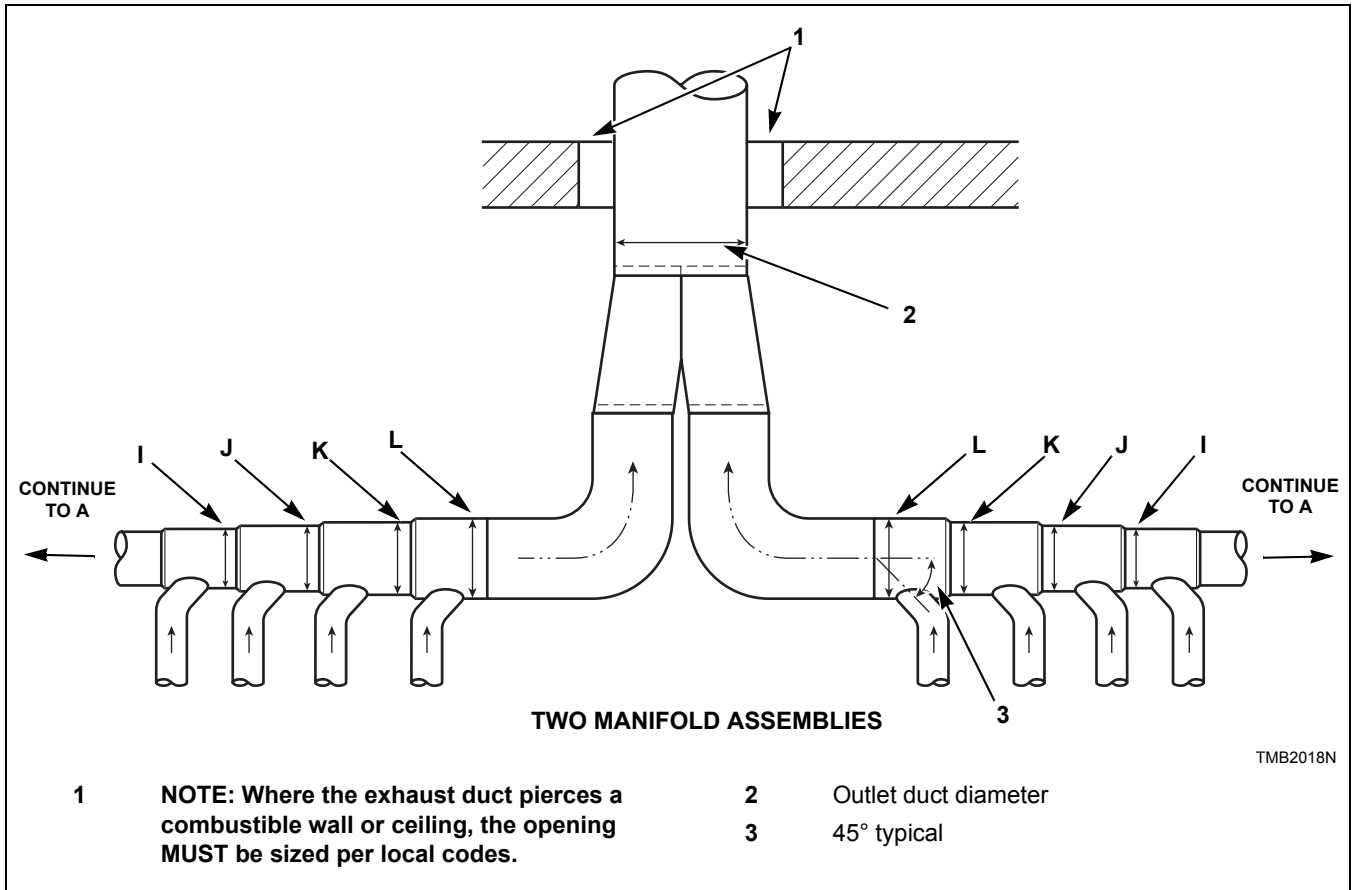



Figure 17

| Duct Station | 50/75 Pound | F75 |
|--------------|---------------------|----------------------|
| | 8 in. (203 mm) Duct | 10 in. (254 mm) Duct |
| A | 13 in. (330 mm) | 15 in. (381 mm) |
| B | 17 in. (432 mm) | 22 in. (559 mm) |
| C | 18 in. (457 mm) | 26 in. (660 mm) |
| D | 24 in. (610 mm) | 30 in. (762 mm) |
| E | 27 in. (686 mm) | 34 in. (864 mm) |
| F | 30 in. (762 mm) | 37 in. (940 mm) |
| G | 33 in. (838 mm) | 40 in. (1016 mm) |
| H | 34 in. (864 mm) | 43 in. (1092 mm) |
| I | 37 in. (940 mm) | 46 in. (1168 mm) |
| J | 39 in. (991 mm) | 47 in. (1194 mm) |
| K | 40 in. (1016 mm) | 50 in. (1270 mm) |
| L | 42 in. (1067 mm) | 51 in. (1295 mm) |

Table 4

Gas Requirements

| | |
|--|----------------|
|  | WARNING |
| <p>To reduce the risk of fire or explosion, DO NOT CONNECT THE GAS LINE TO THE TUMBLER IF THE GAS SERVICE IS NOT THE SAME AS THAT SPECIFIED ON THE TUMBLER SERIAL PLATE! It will first be necessary to convert the gas burner orifice and gas valve. Appropriate conversion kits are available.</p> | |
| <small>W060</small> | |

IMPORTANT: Any product revisions or conversions must be made by the Manufacturer's Authorized Dealers, Distributors or local service personnel.

IMPORTANT: The tumbler must be isolated from the gas supply piping system by closing its individual manual shut-off valve during any pressure testing of the gas supply piping system at test pressure equal to or less than 0.5 psig (3.45 kPa, 34.5 mbar).

IMPORTANT: The tumbler and its manually operated appliance gas valve must be disconnected from the gas supply piping system during any pressure testing of that system at test pressures in excess of 0.5 psi (3.45 kPa, 34.5 mbar).

IMPORTANT: The installation must comply with local codes or, in the absence of local codes:

- with the latest edition of the "National Fuel Gas Code," ANSI Z223.1/NFPA 54 in the U.S.A.,
- with CAN/CSA-B149.1 or Natural Gas and Propane Installation Code in Canada,
- and Australian Gas Association/Australian L.P. Gas Association requirements in Australia.

Obtain specific gas service pipe size from the gas supplier. Refer to *Table 5* for general pipe size.

The following must be furnished and installed by the customer for the gas service line to each tumbler. Refer to *Figure 18*.

- Sediment traps
- Shut-off valves
- Supply pressure taps

It is important that equal pressure be maintained at all tumbler gas connections. This can be done by installing a 1 inch (25.4 mm) pipe gas loop to maintain equal pressure at all gas connections. Refer to *Figure 19*.

| | |
|---|----------------|
|  | WARNING |
| <p>To reduce the risk of fire or explosion, if the tumbler is to be connected to Liquefied Petroleum (L.P.) gas, a vent to the outdoors must be provided in the room where the tumbler is installed.</p> | |
| <small>W062</small> | |

NATURAL GAS line pressure must be maintained at 6.5 water column inches (1.62 kPa), with no less than 5 water column inches (1.24 kPa) and no more than 10.5 water column inches (2.61 kPa), with all gas appliances running (tumblers, water heaters, space heaters, furnace, etc.). An in-line pressure regulator may be required if the line pressure exceeds 8 water column inches (2.0 kPa) with all gas appliances running.

LIQUID PETROLEUM GAS (L.P.) line pressure must be maintained at 11 water column inches (2.74 kPa), with no less than 10 water column inches (2.49 kPa) and no more than 13 water column inches (3.23 kPa), with all gas appliances running (tumblers, water heaters, space heaters, furnace, etc.).

For converting NON-CE models from Natural Gas to L.P. Gas:

- 50 Pound - M4379P3
- 75 Pound - M4454P3
- F75 Pound - M4609P3

CE GASES refers to *Installing CE Gas Drying Tumblers* section, the above data does not apply to the CE.

Gas Requirements

Turn on gas and check all pipe connections (internal and external) for gas leaks with a non-corrosive leak detection fluid. Purge air in gas service line by operating the tumblers in the drying mode. If burner does not light and unit goes into lockout, open and close the door and restart. Repeat these steps until burner ignites. **Use pipe compound, resistant to actions of L.P. gas, on all pipe threads.**

| | |
|--|----------------|
|  | WARNING |
| <p>Check all pipe connections, internal and external, for gas leaks using a non-corrosive leak detection fluid. To reduce the risk of explosion or fire, DO NOT USE AN OPEN FLAME TO CHECK FOR GAS LEAKS! Gas connections should be checked twice a year for leakage.</p> | |
| <small>W635</small> | |

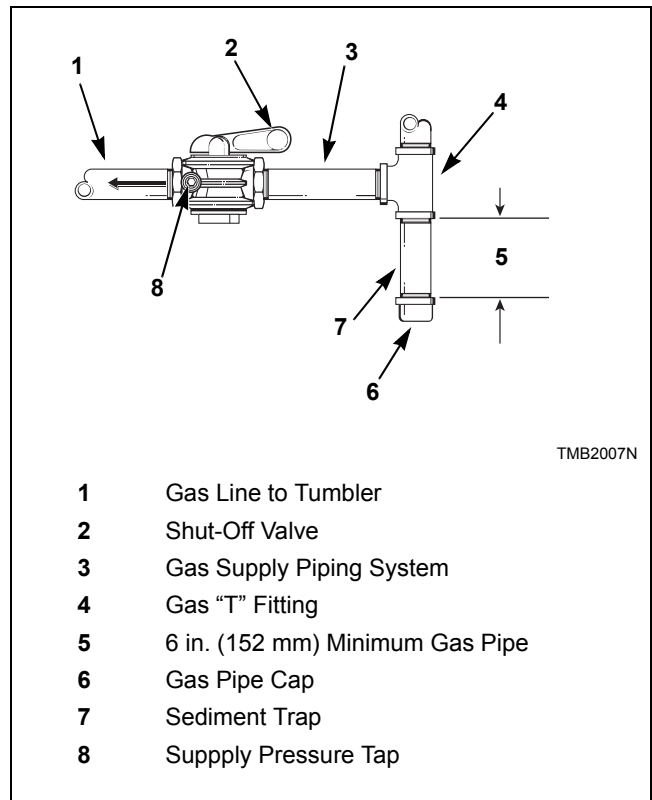
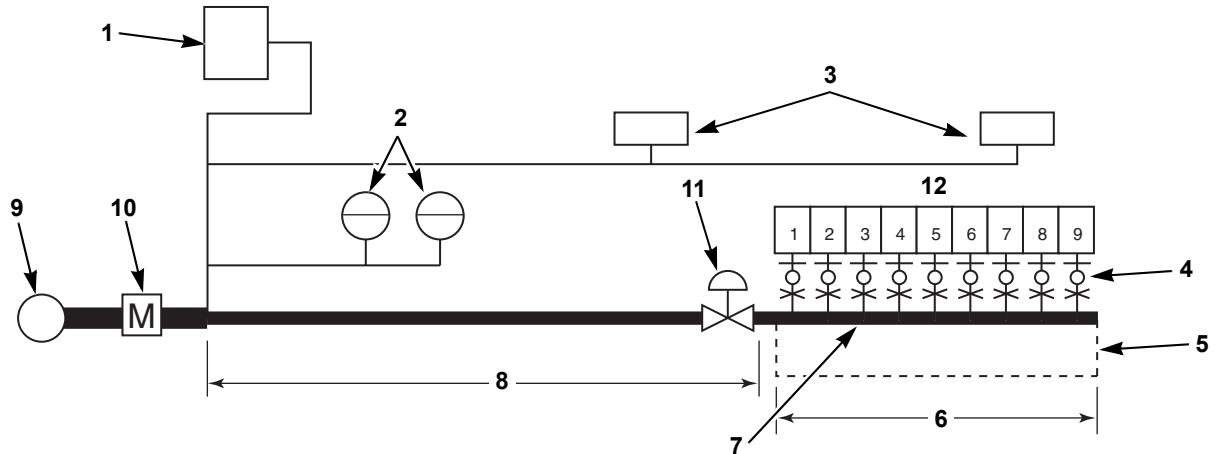

Figure 18

Gas Supply Pipe Sizing and Looping



TMB2126N

- | | | | |
|----------|---|-----------|--|
| 1 | Gas furnace (120,000 Btu/hr.) | 7 | Minimum Pipe Size is 0.5 in. (12.7 mm) |
| 2 | Gas water heaters (400,000 Btu/hr. each) | 8 | 25 ft. (7.6 m) |
| 3 | Gas space heaters (70,000 Btu/hr. each) | 9 | Main regulator |
| 4 | Sediment traps, supply pressure taps and shut-off valves. Refer to <i>Figure 18</i> . | 10 | Gas meter |
| 5 | 1 in. (25.4 mm) gas pipe loop | 11 | Pressure regulator (if required) |
| 6 | 19 ft. (5.8 m) | 12 | 50 pound tumblers (120,000 Btu/hr each) 75 pound tumblers (165,000 Btu/hr each) F75 pound tumblers (215,000 Btu/hr each) |

SAMPLE CALCULATIONS:

Equivalent length = Total length of main gas supply pipe to the far end of the tumblers.
 = 25 ft. + 19 ft. (7.6 m + 5.8 m) gas supply pipe
 = 44 ft. (13.4 m) Total Gas Line

Total Btu/hr. = The sum of the Btu/hr. of all 50 pound tumblers being fed by the main gas supply pipe.
 = 9 x 120,000
 = 1,080,000 Btu/hr.

Using *Table 5*, the main supply pipe diameter should be 2 in. (51 mm).

IMPORTANT: Gas loop piping must be installed as illustrated to equalize gas pressure for all tumblers connected to single gas service. Other gas using appliances should be connected upstream from loop.

Figure 19

Gas Requirements

| Gas Pipe Size Required for 1000 Btu Natural Gas — 0.64 Specific Gravity at 7 ± 1.5 inches (17.4 ± 4 mbar, 1.74 ± 0.37 kPa) Water Column Pressure | | | | | | |
|---|--|------------------------------|------------------------------|-------------------------------|-------------------------------|-------------------------------|
| Gas Appliances Total Btu/hr | Equivalent Length | | | | | |
| | 25 feet (7.63 m) | 50 feet (15.25 m) | 75 feet (22.88 m) | 100 feet (30.50 m) | 125 feet (38.13 m) | 150 feet (45.75 m) |
| | Based on 0.3 in. Water Column Pressure Drop for Length Given Sizes shown in inches (mm) | | | | | |
| 100,000 | 0.75 (19.05) | 0.75 (19.05) | 1 (25.40) | 1 (25.40) | 1 (25.40) | 1 (25.40) |
| 120,000 | 0.75 (19.05) | 1 (25.40) | 1 (25.40) | 1 (25.40) | 1 (25.40) | 1 (25.40) |
| 140,000 | 0.75 (19.05) | 1 (25.40) | 1 (25.40) | 1 (25.40) | 1 (25.40) | 1.25 (31.75) |
| 160,000 | 0.75 (19.05) | 1 (25.40) | 1 (25.40) | 1.25 (31.75) | 1.25 (31.75) | 1.25 (31.75) |
| 180,000 | 1 (25.40) | 1 (25.40) | 1 (25.40) | 1.25 (31.75) | 1.25 (31.75) | 1.25 (31.75) |
| 200,000 | 1 (25.40) | 1 (25.40) | 1.25 (31.75) | 1.25 (31.75) | 1.25 (31.75) | 1.5 (38.10) |
| 300,000 | 1 (25.40) | 1.25 (31.75) | 1.25 (31.75) | 1.5 (38.10) | 1.5 (38.10) | 1.5 (38.10) |
| 400,000 | 1.25 (31.75) | 1.25 (31.75) | 1.5 (38.10) | 1.5 (38.10) | 1.5 (38.10) | 2 (50.80) |
| 500,000 | 1.25 (31.75) | 1.5 (38.10) | 1.5 (38.10) | 2 (50.80) | 2 (50.80) | 2 (50.80) |
| 600,000 | 1.5 (38.10) | 1.5 (38.10) | 2 (50.80) | 2 (50.80) | 2 (50.80) | 2 (50.80) |
| 700,000 | 1.5 (38.10) | 2 (50.80) | 2 (50.80) | 2 (50.80) | 2 (50.80) | 2.5 (63.50) |
| 800,000 | 1.5 (38.10) | 2 (50.80) | 2 (50.80) | 2 (50.80) | 2.5 (63.50) | 2.5 (63.50) |
| 900,000 | 2 (50.80) | 2 (50.80) | 2 (50.80) | 2.5 (63.50) | 2.5 (63.50) | 2.5 (63.50) |
| 1,000,000 | 2 (50.80) | 2 (50.80) | 2 (50.80) | 2.5 (63.50) | 2.5 (63.50) | 2.5 (63.50) |
| 1,100,000 | 2 (50.80) | 2 (50.80) | 2.5 (63.50) | 2.5 (63.50) | 2.5 (63.50) | 2.5 (63.50) |
| 1,200,000 | 2 (50.80) | 2 (50.80) | 2.5 (63.50) | 2.5 (63.50) | 2.5 (63.50) | 2.5 (63.50) |
| 1,300,000 | 2 (50.80) | 2.5 (63.50) | 2.5 (63.50) | 2.5 (63.50) | 2.5 (63.50) | 3 (76.20) |
| 1,400,000 | 2 (50.80) | 2.5 (63.50) | 2.5 (63.50) | 2.5 (63.50) | 3 (76.20) | 3 (76.20) |
| 1,500,000 | 2 (50.80) | 2.5 (63.50) | 2.5 (63.50) | 2.5 (63.50) | 3 (76.20) | 3 (76.20) |
| 1,600,000 | 2 (50.80) | 2.5 (63.50) | 2.5 (63.50) | 3 (76.20) | 3 (76.20) | 3 (76.20) |
| 1,700,000 | 2 (50.80) | 2.5 (63.50) | 2.5 (63.50) | 3 (76.20) | 3 (76.20) | 3 (76.20) |
| 1,800,000 | 2.5 (63.50) | 2.5 (63.50) | 3 (76.20) | 3 (76.20) | 3 (76.20) | 3 (76.20) |
| 1,900,000 | 2.5 (63.50) | 2.5 (63.50) | 3 (76.20) | 3 (76.20) | 3 (76.20) | 3 (76.20) |
| 2,000,000 | 2.5 (63.50) | 2.5 (63.50) | 3 (76.20) | 3 (76.20) | 3 (76.20) | 3.5 (88.90) |
| 2,200,000 | 2.5 (63.50) | 3 (76.20) | 3 (76.20) | 3 (76.20) | 3.5 (88.90) | 3.5 (88.90) |
| 2,400,000 | 2.5 (63.50) | 3 (76.20) | 3 (76.20) | 3 (76.20) | 3.5 (88.90) | 3.5 (88.90) |
| 2,600,000 | 2.5 (63.50) | 3 (76.20) | 3 (76.20) | 3.5 (88.90) | 3.5 (88.90) | 3.5 (88.90) |
| 2,800,000 | 2.5 (63.50) | 3 (76.20) | 3 (76.20) | 3.5 (88.90) | 3.5 (88.90) | 3.5 (88.90) |
| 3,000,000 | 2.5 (63.50) | 3 (76.20) | 3.5 (88.90) | 3.5 (88.90) | 3.5 (88.90) | 4 (101.60) |

For L.P. Gas, correct the total Btu/hr by multiplying it by 0.6. The answer is the equivalent Btu on the above chart.

The installation must conform with local codes or, in the absence of local codes:

- with the latest edition of the “National Fuel Gas Code,” ANSI Z223.1/NFPA 54 in the U.S.A.,
- with CAN/CSA-B149.1 or Natural Gas and Propane Installation Code in Canada,
- and Australian Gas Association/Australian L.P. Gas Association requirements in Australia.

Table 5

High Altitude Burner Orifice Sizing

For proper operation at altitudes above 2000 feet (610 m), the gas burner orifice size must be reduced to ensure complete combustion. Refer to *Table 6*.

For CE models, consult local gas supplier.

| Model | Gas | Altitude | | Burner Orifice | | | | | New Rate (Btu/hr.)* |
|----------|-------------|-------------|-----------|----------------|--------|-----|----------|-------------|------------------------|
| | | feet | meters | No. | inches | mm | Quantity | Part Number | |
| 50 Pound | Natural Gas | 2001-6000 | 610-1830 | 28 | 0.1405 | 3.6 | 2 | M401014 | 110,400 |
| | | 6001-8000 | 1831-2440 | 29 | 0.1360 | 3.4 | | M400997 | 100,800 |
| | | 8001-10,000 | 2441-3050 | 30 | 0.1285 | 3.3 | | M401021 | 91,200 |
| | L.P. Gas | 2001-4000 | 610-1220 | 44 | 0.0860 | 2.2 | | M401011 | 110,400 |
| | | 4001-6000 | 1221-1830 | 45 | 0.0820 | 2.1 | | M401027 | 100,800 |
| | | 6001-8000 | 1831-2440 | 46 | 0.0810 | 2.1 | | M401003 | 91,200 |
| | | 8001-10,000 | 2441-3050 | 47 | 0.0785 | 2.0 | | M400999 | 81,600 |
| 75 Pound | Natural Gas | 2001-4000 | 610-1220 | 29 | 0.1360 | 3.4 | 3 | M400997 | 151,800 |
| | | 4001-8000 | 1221-2440 | 30 | 0.1285 | 3.3 | | M401021 | 138,600 |
| | | 8001-10,000 | 2441-3050 | 31 | 0.1200 | 3.0 | | M401017 | 125,400 |
| | L.P. Gas | 2001-4000 | 610-1220 | 45 | 0.0820 | 2.1 | | M401027 | 151,800 |
| | | 4001-6000 | 1221-1830 | 46 | 0.0810 | 2.1 | | M401003 | 138,600 |
| | | 6001-8000 | 1831-2440 | 47 | 0.0785 | 2.0 | | M400999 | 125,400 |
| | | 8001-10,000 | 2441-3050 | 48 | 0.0760 | 1.9 | | M401001 | 112,200 |
| F75 | Natural Gas | 2001-4000 | 610-1220 | 23 | 0.1540 | 3.9 | 3 | M401020 | 197,800 |
| | | 4001-6000 | 1221-1830 | 25 | 0.1495 | 3.8 | | M402997 | 180,600 |
| | | 6001-8000 | 1831-2440 | 27 | 0.1440 | 3.7 | | M400998 | 163,400 |
| | | 8001-10,000 | 2441-3050 | 29 | 0.1360 | 3.4 | | M400997 | 146,200 |
| | L.P. Gas | 2001-4000 | 610-1220 | 42 | 0.0935 | 2.4 | | M403017 | 197,800 |
| | | 4001-6000 | 1221-1830 | 43 | 0.0890 | 2.3 | | M406184 | 180,600 |
| | | 6001-8000 | 1831-2440 | 44 | 0.0860 | 2.2 | | M401011 | 163,400 |
| | | 8001-10,000 | 2441-3050 | 45 | 0.0820 | 2.1 | | M401027 | 146,200 |

* Btu/hr. derate of 4% per 1000 feet (305 meters) of altitude.

Table 6

Electrical Requirements

| | |
|---|----------------|
|  | WARNING |
| <p>To reduce the risk of electric shock, fire, explosion, serious injury or death:</p> <ul style="list-style-type: none">• Disconnect electric power to the tumbler before servicing.• Close gas shut-off valve to gas tumbler before servicing.• Close steam valve to steam tumbler before servicing.• Never start the tumbler with any guards/panels removed.• Whenever ground wires are removed during servicing, these ground wires must be reconnected to ensure that the tumbler is properly grounded. <p style="text-align: right;">W002</p> | |
| <p>To reduce the risk of fire and electric shock, check with a qualified serviceman for proper grounding procedures. Improper connection of the equipment grounding conductor may result in a risk of electric shock.</p> <p style="text-align: right;">W068</p> | |
| <p>To reduce the risk of fire and electric shock, if electrical supply is coming from a three phase service, DO NOT connect a “High Leg” or “Stinger Leg” to a single phase machine. On a three phase machine, if there is a “High Leg” or “Stinger Leg” it should be connected to L3.</p> <p style="text-align: right;">W069</p> | |

Grounding Instructions

NOTE: To ensure protection against shock, this tumbler **MUST** be electrically grounded in accordance with the local codes, or in the absence of local codes, with the latest edition of the National Electrical Code ANSI/NFPA No. 70. In Canada the electrical connections are to be made in accordance with CSA C22.1 latest edition Canadian Electrical Code, or local codes. Electrical work should be done by a qualified electrician.

This tumbler must be grounded. In the event of malfunction or breakdown, grounding will reduce the risk of electric shock by providing a path of least resistance for electric current. This tumbler must be connected to a grounded metal, permanent wiring system; or an equipment grounding conductor must be run with the circuit conductors and connected to the appropriate ground location.

- Metal conduit and/or BX cable is not considered ground.
- Connecting the Neutral from the electrical service box to the tumbler ground screw does not constitute a ground.
- A dedicated ground conduit (wire) must be connected between the electrical service box ground bar and tumbler ground screw.

| | |
|---|----------------|
|  | WARNING |
| <p>To reduce the risk of electrical shock, de-energize the electrical circuit being connected to the tumbler before making any electrical connections. All electrical connections should be made by a qualified electrician. Never attempt to connect a live circuit.</p> <p style="text-align: right;">W409</p> | |

| | |
|---|----------------|
|  | CAUTION |
| <p>Label all wires prior to disconnection when servicing controls. Wiring errors can cause improper and dangerous operation. Verify proper operation after servicing.</p> <p style="text-align: right;">W071</p> | |

For CE Models Only

All OPL (non-vend) models are factory-equipped with an emergency stop button on the front panel.

NOTE: Activation of the emergency stop switch stops all machine control circuit functions, but **DOES NOT** remove all electrical power from machine.

Service/Ground Location

| Model | Heat Source | Ground and Terminal Block Locations |
|--------|--------------|--|
| Non-CE | Gas or Steam |  <p>Junction Box TMB1274N</p> |
| Non-CE | Electric |  <p>Accessory Box TMB2124N</p> <p>NOTE: Do not make service connections in junction box.</p> |
| CE | Gas or Steam |  <p>Junction Box TMB1275N</p> |
| CE | Electric |  <p>Junction Box TMB2125N</p> |

Figure 20

Electrical Requirements

To Connect Electrical Service To The Tumbler

The following steps outline the procedure for connecting the electrical service to the tumbler.

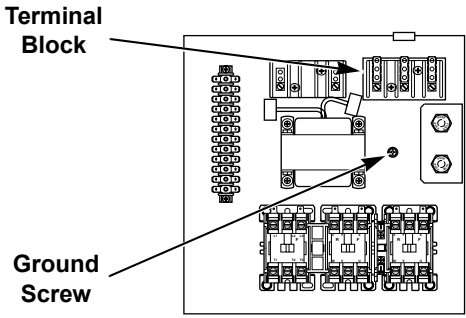
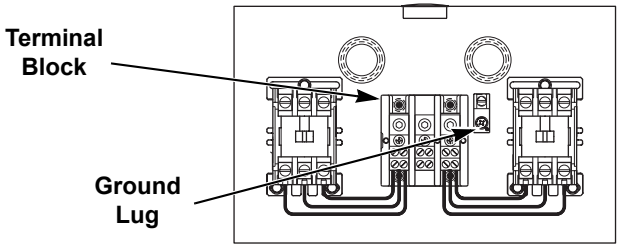
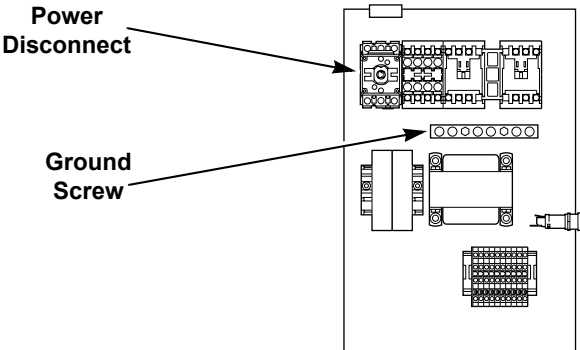
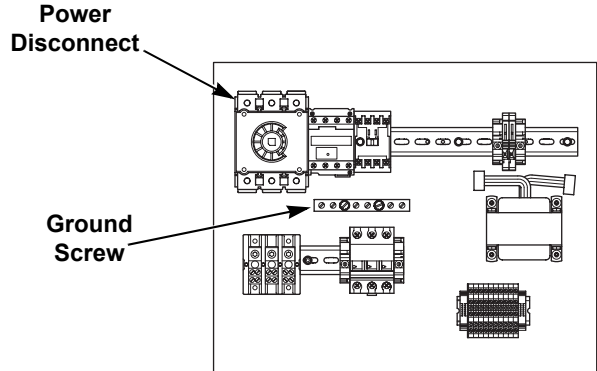
NOTE: The wiring diagram is located in the junction or contactor box.

1. Install a circuit breaker as close to the tumbler as possible. If more than one tumbler is being installed, a disconnect switch or circuit breaker should be provided for each. This will make it possible to disconnect each tumbler for maintenance purposes.
2. Connect the conduit-encased leads to the disconnect switch, or circuit breaker. Connect the wire leads to the appropriate labeled terminal on the terminal block. The ground wire must be connected to the ground connection as shown in *Figure 21*.
3. Check the electrical service phase sequence (three phase only) as follows:
 - a. Energize the electrical service (on reversing tumblers, ensure nonreversing is selected) and momentarily start the tumbler. Check the direction of the cylinder rotation. If the cylinder rotates clockwise (viewed from the front), the phase sequence is correct. If the cylinder rotates counterclockwise, proceed with step b.

NOTE:When viewed from the front, the fan should rotate clockwise on 50 and 75 Pound models and counterclockwise on F75 models.

- b. Disconnect and reverse any two service leads on the terminal block.

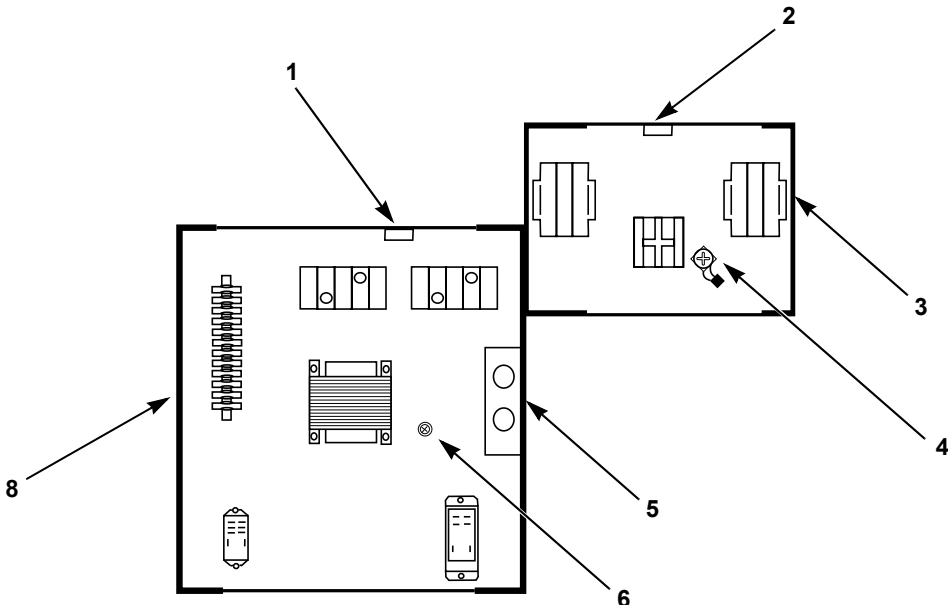

NON-CE MODELS

T224S

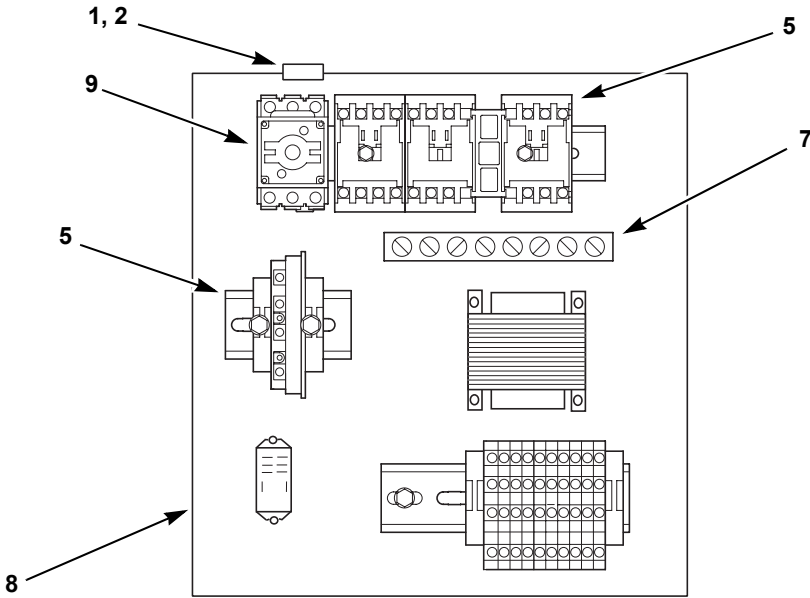

CE MODELS

TMB2017N

- | | | | |
|---|---|---|--|
| 1 | Electrical Service (Gas and Steam Models) | 6 | Ground Screw (Gas and Steam Models Only) |
| 2 | Electrical Service (Electric Models) | 7 | Ground Buss Bar |
| 3 | Accessory Box | 8 | Contactor Box |
| 4 | Ground Lug | 9 | Disconnect Switch |
| 5 | Fuses (Location may vary) | | |

Figure 21

Electrical Requirements

Jumper Configuration Instructions

Changing the transformer configuration jumper is required, **PRIOR TO SUPPLYING POWER TO THE MACHINE**, if any of the following apply:

IMPORTANT: Failure to install the proper configuration jumper may result in damage to sensitive electronic controls and may void warranty.

- You have 200 – 208 Volt service and are connecting a model rated for 240 Volt operation.

Replace the 240 Volt jumper with the 208 Volt jumper per the conversion label, located on the rear of the tumbler, sign and date conversion label to document the conversion.

- You have 400 – 415 Volt service and are connecting a model rated for 380 Volt operation.

NOTE: CE electro-mechanical timer models (MT, RT and CD control suffixes) do NOT require conversion jumper.

Replace the 380 Volt jumper with the 415 Volt jumper per the conversion label, located on the rear of the tumbler, sign and date conversion label to document the conversion.

Ferrite Ring Installation

Gas and Steam OPL Control Models Only

The ferrite ring provided in the literature packet must be installed over the power leads during connection of electrical service. The ferrite protects the sensitive electronic controls from destructive electrical disturbances which may be present on power lines to the machine. Failure to properly install the ferrite ring may result in damage to the electronic controls and will void control warranty.

To install:

1. Immediately after connection of power leads and before applying power to machine, locate each of the incoming service leads including ground.
2. Snap the ferrite ring closed over all the service leads inside of the contactor box as shown. It is important that the ferrite ring be installed inside the contactor box. Refer to *Figure 22*. Do not install the ferrite outside of the box or other area. Make sure that service leads are in the center of the ferrite before closing the ring so as not to pinch or damage leads.

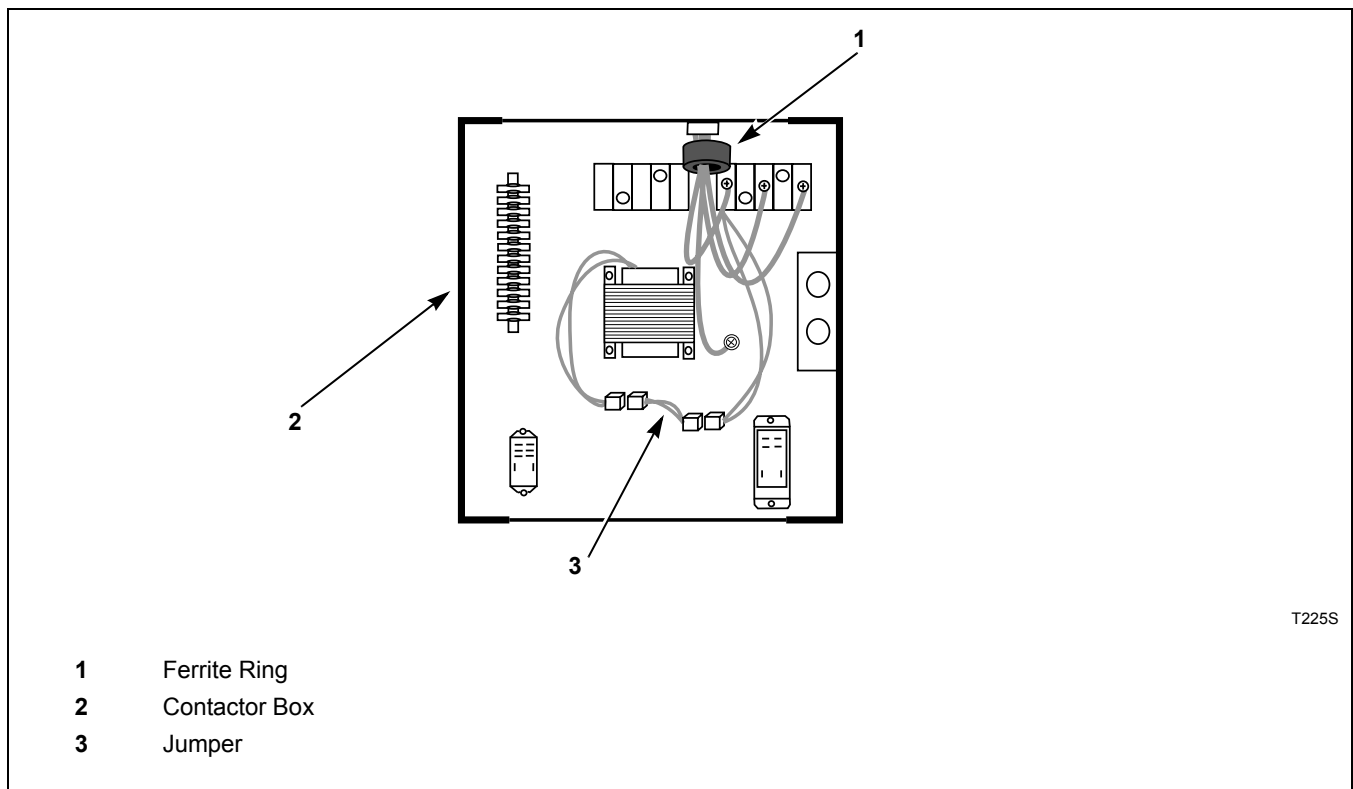

Figure 22

50 Pound Gas and Steam Models

Refer to *Table 7*.

NOTE: Wire sizes were obtained from the Canadian Electrical Code for 75 C. wire and are intended for use as a guideline only. Electrical connections should be made by a qualified electrical contractor in accordance with all applicable local and national requirements.

NOTE: Electrical specifications below are subject to change without notice. Always refer to product serial plate for most current specifications of product being installed.

NOTE: Use copper conductors only.

NOTE: 3 Phase Only – Each tumbler must be connected to its own individual branch circuit breaker, not fuses, to avoid the possibility of “single phasing” and causing premature failure of the motor(s).

| Serial Plate Rating | Terminal Block Connections Required | Serial Plate Amps | | Recommended Circuit | |
|-----------------------|-------------------------------------|-------------------|-----------|---------------------|----------------------------------|
| | | Nonreversing | Reversing | Breaker Rating | Wire Size AWG (mm ²) |
| 120V/60Hz/1ph | L1, Neutral and ground | 9.3 | N/A | 15A – 1 pole | 14 (2.08) |
| 200-208V/60Hz/1ph | L1, Neutral and ground | 5.1 | N/A | 10A – 1 pole | 14 (2.08) |
| 200-208-240V/60Hz/1ph | L1, L2 and ground | 5.1 | N/A | 10A – 2 pole | 14 (2.08) |
| 230-240V/50Hz/1ph | L1, Neutral and ground | 6.3 | 6.9 | 15A – 1 pole | 14 (2.08) |
| 200-208V/60Hz/3ph | L1, L2, L3 and ground | 2.8 | 4.0 | 10A – 3 pole | 14 (2.08) |
| 200V/50Hz/3ph | L1, L2, L3 and ground | 3.3 | 4.2 | 10A – 3 pole | 14 (2.08) |
| 240V/60Hz/3ph | L1, L2, L3 and ground | 2.8 | 4.0 | 10A – 3 pole | 14 (2.08) |
| 230-240V/50Hz/3ph | L1, L2, L3 and ground | 3.1 | 4.3 | 10A – 3 pole | 14 (2.08) |
| 380V/50 or 60Hz/3ph | L1, L2, L3 and ground | 1.6 | 2.0 | 10A – 3 pole | 14 (2.08) |
| 400-415V/50Hz/3ph | L1, L2, L3 and ground | 1.6 | 2.0 | 10A – 3 pole | 14 (2.08) |
| 440V/60Hz/3ph | L1, L2, L3 and ground | 1.4 | 1.9 | 10A – 3 pole | 14 (2.08) |
| 460-480V/60Hz/3ph | L1, L2, L3 and ground | 1.4 | 1.9 | 10A – 3 pole | 14 (2.08) |

N/A = Not Applicable

Table 7

Electrical Requirements

75 Pound Gas and Steam Models

Refer to *Table 8* and *Table 9*.

NOTE: Wire size and breaker ratings were obtained from the Canadian Electrical Code for 75 C. wire and are intended for use as a guideline only. Electrical connections should be made by a qualified electrical contractor in accordance with all applicable local and national requirements.

NOTE: Electrical specifications below are subject to change without notice. Always refer to product serial plate for most current specifications of product being installed.

NOTE: Use copper conductors only.

NOTE: Connect to individual branch circuit.

NOTE: 3 Phase Only – Each tumbler must be connected to its own individual branch circuit breaker, not fuses, to avoid the possibility of “single phasing” and causing premature failure of the motor(s).

| Serial Plate Rating | Terminal Block Connections Required | Serial Plate Amps | | Recommended Circuit | |
|-----------------------|-------------------------------------|-------------------|-----------|---------------------|----------------------------------|
| | | Nonreversing | Reversing | Breaker Rating | Wire Size AWG (mm ²) |
| 120V/60Hz/1ph | L1, Neutral and ground | 13.8 | N/A | 20A – 1 pole | 12 (3.31) |
| 200-208V/60Hz/1ph | L1, Neutral and ground | 7.6 | N/A | 15A – 1 pole | 14 (2.08) |
| 200-208-240V/60Hz/1ph | L1, L2 and ground | 7.6 | N/A | 15A – 2 pole | 14 (2.08) |
| 230-240V/50Hz/1ph | L1, Neutral and ground | 6.7 | 7.0 | 15A – 1 pole | 14 (2.08) |
| 200-208V/60Hz/3ph | L1, L2, L3 and ground | 3.8 | 4.3 | 10A – 3 pole | 14 (2.08) |
| 200V/50Hz/3ph | L1, L2, L3 and ground | 3.5 | 4.5 | 10A – 3 pole | 14 (2.08) |
| 240V/60Hz/3ph | L1, L2, L3 and ground | 3.8 | 4.3 | 10A – 3 pole | 14 (2.08) |
| 230-240V/50Hz/3ph | L1, L2, L3 and ground | 3.5 | 4.9 | 10A – 3 pole | 14 (2.08) |
| 380V/50 or 60Hz/3ph | L1, L2, L3 and ground | 1.8 | 2.1 | 10A – 3 pole | 14 (2.08) |
| 400-415V/50Hz/3ph | L1, L2, L3 and ground | 1.8 | 2.1 | 10A – 3 pole | 14 (2.08) |
| 440V/60Hz/3ph | L1, L2, L3 and ground | 1.9 | 2.1 | 10A – 3 pole | 14 (2.08) |
| 460-480V/60Hz/3ph | L1, L2, L3 and ground | 1.9 | 2.1 | 10A – 3 pole | 14 (2.08) |

N/A = Not Applicable

Table 8

F75 Gas Models Only

| Serial Plate Rating | Terminal Block Connections Required | Serial Plate Amps | | Recommended Circuit | |
|---------------------|-------------------------------------|-------------------|-----------|---------------------|----------------------------------|
| | | Nonreversing | Reversing | Breaker Rating | Wire Size AWG (mm ²) |
| 200-208V/60Hz/3ph | L1, L2, L3 and ground | N/A | 6.3 | 15A – 3 pole | 14 (2.08) |
| 240V/60Hz/3ph | L1, L2, L3 and ground | N/A | 6.3 | 15A – 3 pole | 14 (2.08) |
| 460-480V/60Hz/3ph | L1, L2, L3 and ground | N/A | 3.1 | 10A – 3 pole | 14 (2.08) |

N/A = Not Applicable

Table 9

50 and 75 Pound Electric Models

Refer to *Table 10*.

NOTE: Wire size and breaker ratings were obtained from the Canadian Electrical Code for 75 C. wire and are intended for use as a guideline only. Electrical connections should be made by a qualified electrical contractor in accordance with all applicable local and national requirements.

NOTE: Electrical specifications below are subject to change without notice. Always refer to product serial plate for most current specifications of product being installed.

NOTE: Use copper conductors only.

NOTE: Connect to individual branch circuit.

NOTE: 3 Phase Only – Each tumbler must be connected to its own individual branch circuit breaker, not fuses, to avoid the possibility of “single phasing” and causing premature failure of the motor(s).

| Serial Plate Rating | Terminal Block Connections Required | Serial Plate Amps | | Recommended Circuit | |
|--------------------------------------|-------------------------------------|-------------------|-----------|---------------------|----------------------------------|
| | | Nonreversing | Reversing | Breaker Rating | Wire Size AWG (mm ²) |
| 240V/50Hz/1ph (50 Pound only) | L1, Neutral and Ground | 93 | 95 | 125A – 1 pole | 1 (42.4) |
| 200-208V/60Hz/3ph | L1, L2, L3 and ground | 89 | 88 | 125A – 3 pole | 1 (42.4) |
| 200V/50Hz/3ph | L1, L2, L3 and ground | 84 | 85 | 125A – 3 pole | 1 (42.4) |
| 230V/50Hz/3ph | L1, L2, L3 and ground | 73 | 75 | 100A – 3 pole | 3 (26.7) |
| 240V/50Hz/3ph | L1, L2, L3 and ground | 79 | 78 | 100A – 3 pole | 3 (26.7) |
| 240V/60Hz/3ph | L1, L2, L3 and ground | 79 | 78 | 100A – 3 pole | 3 (26.7) |
| 380V/50 or 60Hz/3ph | L1, L2, L3 and ground | 47 | 48 | 60A – 3 pole | 6 (13.3) |
| 400-415V/50Hz/3ph | L1, L2, L3 and ground | 43 | 44 | 60A – 3 pole | 6 (13.3) |
| 440V/60Hz/3ph | L1, L2, L3 and ground | 41 | 41 | 51A – 3 pole | 6 (13.3) |
| 480V/60Hz/3ph | L1, L2, L3 and ground | 38 | 38 | 50A – 3 pole | 6 (13.3) |

Table 10

Steam Requirements

NOTE: Machines require a constant 80 to 100 psig (5.62 to 7.03 kg/sq cm) steam service for optimum operation. The maximum allowable steam pressure for use with 60 Hertz or 50 Hertz tumblers is 125 psig (8.6 bar). In no case may the pressure exceed the above value.

Obtain specific steam service pipe sizes from steam system supplier or a qualified steam fitter.

- Refer to *Figure 23* for proper steam pipe configurations.
- To prevent condensate draining from headers to tumbler, piping should have a minimum 12 inch (305 mm) rise above respective header. Do not make steam connection to header with a horizontal or downward facing tee or elbow.
- Whenever possible, horizontal runs of steam lines must drain, by gravity, to respective steam header. Water pockets, or an improperly drained steam header will provide wet steam, causing improper operation of tumbler. If pockets or improper drainage cannot be eliminated, install a bypass trap to drain condensate from the low point in the steam header to the return.
- In both steam supply and steam return line, it is recommended that each have a pipe union and shut-off valve. This will enable you to disconnect the steam connections and service the tumbler while your laundry facility is in operation.
- Connect the steam solenoid valve to the related steam coil inlet connection with nipples, flex hoses, unions and tees.
- Strainers may require cleaning due to materials from hoses or pipes.
- Install vacuum breaker (optional), bucket trap with built-in strainer and check valve. For successful operation of tumbler, install trap 18 inches (457 mm) below coil and as near to the tumbler as possible. Inspect trap carefully for inlet and outlet markings and install according to trap manufacturer's instructions. If steam is gravity returned to boiler, omit trap but install vacuum breaker and check valve in return line near tumbler. Gravity return requires entire return plumbing be below steam coil outlets.
- Install union and shut-off valve in return line and make final pipe connections to return header.

NOTE: To prevent water hammering, route return lines below outlets of steam coils.

Piping Recommendations

- Trap each steam coil individually. Always keep the trap clean and in good working condition.
- When tumbler is on the end of a line of equipment, extend header at least 4 feet (1.2 m) beyond tumbler. Install shut-off valve, union, check valve and bypass trap at end of line. If gravity return to boiler, omit trap.
- Insulate steam supply and return lines for safety of operator and safety while servicing tumbler.
- Keep tumbler in good working condition. Repair or replace any worn or defective parts.

| | |
|--|----------------|
|  | WARNING |
| <p>All system components must have a 125 psig (8.6 bar) working pressure. Shut-off valves must be installed upstream of the steam solenoid valve and downstream of each steam trap so components can be isolated for maintenance or emergency purposes.</p> <p>All components (solenoid valve, traps) must be supported to minimize loads on the tumbler steam coil connections.</p> | |
| <small>W480R2</small> | |

| | |
|---|----------------|
|  | WARNING |
| <p>The flexible steam hoses connecting the coil outlet connections and steam traps must have a minimum of 125 psig (pounds per square inch gauge) (8.79 kg/sq. cm.) working pressure. A shut-off valve must be installed downstream from each steam trap so the condensate return line can be isolated in event a steam trap requires maintenance.</p> <p>Each steam trap must be supported so minimum load is exerted on the coil outlet connection.</p> | |
| <small>W066</small> | |

Thermal Oil Prep

It is the responsibility of the customer to install appropriate coil and heating system for thermal oil prep models. Alliance Laundry Systems, LLC. is not responsible for the performance or safety of the customer installed thermal oil system. To ensure proper operation, refer to the *Specifications and Dimensions* section for the BTU input of equivalent steam models. Thermal oil systems that do not deliver appropriate BTUs will dry slower. For solenoid valve wiring connections, refer to the Wiring Diagram supplied with tumbler.

Installing Steam Trap and Making Condensate Return Connections

The steam trap must be installed and the coil outlet connections must be connected to the condensate return lines. The following steps outline the procedure for installing the steam trap and connecting the condensate return lines. Refer to *Figure 23* for typical installations.

1. Use flexible lines between steam inlet solenoid and steam coils, as well as outlet between steam coil and traps.
2. If necessary, install a strainer at the end of each flexible hose.
3. Install a steam trap to each strainer.

IMPORTANT: Steam trap must be installed a minimum of 18 inches (457 mm) below the steam coil outlet connections.

4. Install a shut-off valve to each steam trap.
5. Connect to the condensate return lines.
6. For steam solenoid valve wiring connections, refer to Wiring Diagram supplied with tumbler.

Steam Requirements

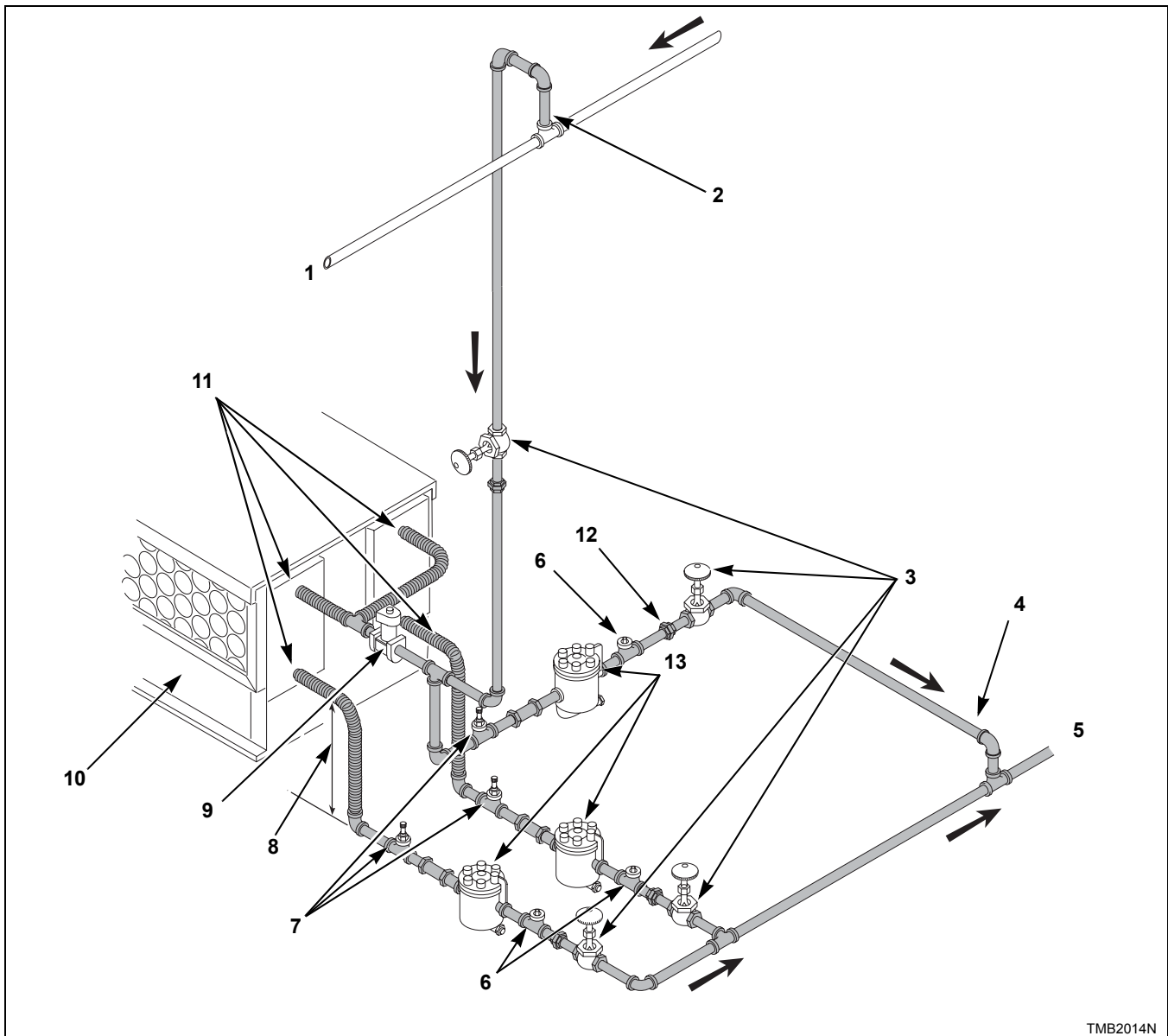

TMB2014N

NOTE: Refer to Table 11 for sizing of steam lines. Piping must also be sized accordingly for length of runs, and number of elbows.

- | | | | |
|---|---|----|--|
| 1 | Supply | 8 | 18 in. (457 mm) Drop |
| 2 | 12 in. (305 mm) Riser | 9 | Solenoid Valve (Supplied with machine) |
| 3 | Shut-Off Valve | 10 | Steam Bonnet |
| 4 | Condensate Return Line from Supply Line | 11 | Flexible Line |
| 5 | Return | 12 | Union |
| 6 | Check Valve | 13 | Trap with Built-In Strainer |
| 7 | Vacuum Breaker (Optional) | | |

Figure 23

| Steam Pressure PSI (bar) | Minimum Pipe Diameter | Steam Trap Size* (Pounds Condensate/Hour) |
|--------------------------|-----------------------|---|
| 80 – 100 (5.3-6.9) | 3/4 in. NPT | 160 |

*Based on 100 psi.

Table 11

Single Drop Timer

NOTE: The following information is for models with an SD control suffix only.

Power-Up Mode

When power is applied to the tumbler, the *IN USE* light flashes factory status information. Following this, the control goes into READY Mode (light off) or RUN Mode if power was interrupted during a cycle (light on, time remaining unchanged).

Ready Mode

In READY Mode (light off), the control waits for the vend to be satisfied. When vend is satisfied the control goes into START Mode.

Start Mode

In START Mode (light on), the vend has been satisfied but the start button has not been pressed. Time remaining in the cycle will not change until the start button is pressed. When the start button is pressed the machine goes into RUN Mode.

Run Mode

In RUN Mode (light on), the machine is running a cycle and the time remaining is counting down. When time remaining counts down to zero, the control goes into READY Mode.

Setting Dry Time Dipswitches

To change the dry time on the tumbler, combinations of dipswitches can be set on the control.

There are eight dipswitches on the tumbler control. The first six switches are used to program the amount of additional heat time given for each coin pulse. The additional drying time is added to the factory default minimum heat time of one minute. A value of 1 to 64 minutes of additional drying time is available for each coin drop pulse.

The last two switches are used to program the amount of additional cool down time. The additional cool down time is added to the factory default minimum cool down time of 1 minute. A value of 1 to 3 additional minutes is available. The control is shipped from the factory programmed with 1 minute of minimum heat time, preset with 7 additional minutes of drying time (dipswitches 1, 2 and 3 in ON position) and 1 minute of minimum cool down time for a total time of 9 minutes for a coin pulse. For dipswitch settings Refer to *Table 12*.

The control reads the dipswitch settings at power-up. The control must be powered down to change the dipswitch settings.

To change the time for a coin pulse, the desired dry time dipswitches must be set to ON position. All other dipswitches must be in OFF position.

Single Drop Timer

Dipswitch Settings

| Heat Time Per Coin Pulse (in Minutes) | Heat Switch Number | | | | | |
|---------------------------------------|--------------------|-----|-----|-----|-----|-----|
| | 1 | 2 | 3 | 4 | 5 | 6 |
| 1 | OFF | OFF | OFF | OFF | OFF | OFF |
| 2 | ON | OFF | OFF | OFF | OFF | OFF |
| 3 | OFF | ON | OFF | OFF | OFF | OFF |
| 4 | ON | ON | OFF | OFF | OFF | OFF |
| 5 | OFF | OFF | ON | OFF | OFF | OFF |
| 6 | ON | OFF | ON | OFF | OFF | OFF |
| 7 | OFF | ON | ON | OFF | OFF | OFF |
| 8 (factory default) | ON | ON | ON | OFF | OFF | OFF |
| 9 | OFF | OFF | OFF | ON | OFF | OFF |
| 10 | ON | OFF | OFF | ON | OFF | OFF |
| 11 | OFF | ON | OFF | ON | OFF | OFF |
| 12 | ON | ON | OFF | ON | OFF | OFF |
| 13 | OFF | OFF | ON | ON | OFF | OFF |
| 14 | ON | OFF | ON | ON | OFF | OFF |
| 15 | OFF | ON | ON | ON | OFF | OFF |
| 16 | ON | ON | ON | ON | OFF | OFF |
| 17 | OFF | OFF | OFF | OFF | ON | OFF |
| 18 | ON | OFF | OFF | OFF | ON | OFF |
| 19 | OFF | ON | OFF | OFF | ON | OFF |
| 20 | ON | ON | OFF | OFF | ON | OFF |
| 21 | OFF | OFF | ON | OFF | ON | OFF |
| 22 | ON | OFF | ON | OFF | ON | OFF |
| 23 | OFF | ON | ON | OFF | ON | OFF |
| 24 | ON | ON | ON | OFF | ON | OFF |
| 25 | OFF | OFF | OFF | ON | ON | OFF |
| 26 | ON | OFF | OFF | ON | ON | OFF |
| 27 | OFF | ON | OFF | ON | ON | OFF |
| 28 | ON | ON | OFF | ON | ON | OFF |
| 29 | OFF | OFF | ON | ON | ON | OFF |
| 30 | ON | OFF | ON | ON | ON | OFF |
| 31 | OFF | ON | ON | ON | ON | OFF |
| 32 | ON | ON | ON | ON | ON | OFF |
| 33 | OFF | OFF | OFF | OFF | OFF | ON |
| 34 | ON | OFF | OFF | OFF | OFF | ON |
| 35 | OFF | ON | OFF | OFF | OFF | ON |

| Cool Down Switch Number | | Cool Down Per Cycle (in Minutes) |
|-------------------------|-----|----------------------------------|
| 7 | 8 | |
| OFF | OFF | 1 (factory default) |
| ON | OFF | 2 |
| OFF | ON | 3 |
| ON | ON | 4 |

Table 12 (Continued)

Table 12 (Continued)

| Heat Time Per Coin Pulse (in Minutes) | Heat Switch Number | | | | | |
|---------------------------------------|--------------------|-----|-----|-----|-----|----|
| | 1 | 2 | 3 | 4 | 5 | 6 |
| 36 | ON | ON | OFF | OFF | OFF | ON |
| 37 | OFF | OFF | ON | OFF | OFF | ON |
| 38 | ON | OFF | ON | OFF | OFF | ON |
| 39 | OFF | ON | ON | OFF | OFF | ON |
| 40 | ON | ON | ON | OFF | OFF | ON |
| 41 | OFF | OFF | OFF | ON | OFF | ON |
| 42 | ON | OFF | OFF | ON | OFF | ON |
| 43 | OFF | ON | OFF | ON | OFF | ON |
| 44 | ON | ON | OFF | ON | OFF | ON |
| 45 | OFF | OFF | ON | ON | OFF | ON |
| 46 | ON | OFF | ON | ON | OFF | ON |
| 47 | OFF | ON | ON | ON | OFF | ON |
| 48 | ON | ON | ON | ON | OFF | ON |
| 49 | OFF | OFF | OFF | OFF | ON | ON |
| 50 | ON | OFF | OFF | OFF | ON | ON |
| 51 | OFF | ON | OFF | OFF | ON | ON |
| 52 | ON | ON | OFF | OFF | ON | ON |
| 53 | OFF | OFF | ON | OFF | ON | ON |
| 54 | ON | OFF | ON | OFF | ON | ON |
| 55 | OFF | ON | ON | OFF | ON | ON |
| 56 | ON | ON | ON | OFF | ON | ON |
| 57 | OFF | OFF | OFF | ON | ON | ON |
| 58 | ON | OFF | OFF | ON | ON | ON |
| 59 | OFF | ON | OFF | ON | ON | ON |
| 60 | ON | ON | OFF | ON | ON | ON |
| 61 | OFF | OFF | ON | ON | ON | ON |
| 62 | ON | OFF | ON | ON | ON | ON |
| 63 | OFF | ON | ON | ON | ON | ON |
| 64 | ON | ON | ON | ON | ON | ON |

Total Cycle Time = Heat Time + Cool Down Time

Table 12

Rotary Coin Drop Timer

NOTE: The following information is for models with a CD control suffix only.

Installing Accessory Timing Cam

Non-electronic, rotary coin drop tumblers have eight accessory cams in the literature package. These allow you to change your vending times. Refer to *Table 13*. Timer motor rpm is printed on the timer motor.

| Cam Pins | Vend Times (minutes) | |
|----------|----------------------|----------------------|
| | 1/30 rpm Timer Motor | 1/60 rpm Timer Motor |
| 2 | 15 | 30 |
| 3 | 10 | 20 |
| 4 | 7.5 | 15 |
| 5 | 6 | 12 |
| 6 | 5 | 10 |
| 8 | 3.75 | 7.5 |
| 10 | 3 | 6 |
| 12 | 2.5 | 5 |

Table 13

Removal of Existing Timing Cam

1. Rotate cam by hand until “V” notch lines up beneath the ratchet tooth. Refer to *Figure 24*.
2. Insert narrow screwdriver under nylon cam, close to the clock shaft. Lift gently off shaft. Make sure that pressure is directed upward and that the “V” notch clears the ratchet tooth.

Installation of New Timing Cam

1. Insert drive fork into timing cam with wide prong in wide hole of cam.
2. Position timing cam and drive fork over the timer shaft, aligning the timer flat with the drive fork and the “V” notch with one of the ratchet teeth.
3. Press timing cam down firmly to seat timing cam onto the motor shaft.

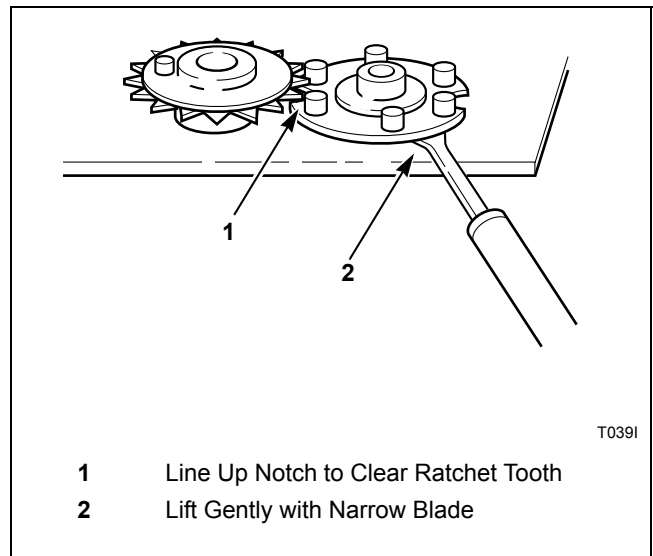

Figure 24

4. Remove all accumulated time by turning cam counterclockwise until switch shuts off. Apply moderate clockwise pressure to fully seated timing cam and drive against the timing motor shaft. Meter must be advanced electrically for one cycle before an accurate measure of time can be made.

Adjustments



WARNING

To reduce the risk of electric shock, fire, explosion, serious injury or death:

- Disconnect electric power to the tumbler before servicing.
- Close gas shut-off valve to gas tumbler before servicing.
- Close steam valve to steam tumbler before servicing.
- Never start the tumbler with any guards/panels removed.
- Whenever ground wires are removed during servicing, these ground wires must be reconnected to ensure that the tumbler is properly grounded.

W002

Gas Burner Air Shutter

NOTE: Air inlet shutters on the burner must be adjusted so sufficient air is metered into the system for proper combustion and maximum efficiency. Before adjusting the inlet shutters be sure that all lint is removed from lint compartments and lint screen.

Air shutter adjustments will vary from location to location and will depend on the vent system, number of units installed, make-up air and line gas pressure. Opening the shutter increases the amount of primary air supplied to the burner while closing the shutter decreases the primary air supply. Adjust air shutter as follows:

Refer to *Figure 25*.

1. Open the access panel.
2. Start the tumbler and check the flame pattern. If the flame pattern is straight up, insufficient air is flowing through the tumbler and airflow switch is improperly set. A flame pattern that flares to the right and left indicates no air is flowing through the tumbler. Correct air and gas mixture is indicated if the flame pattern is primarily blue, with small yellow tips, and bends to the right of the heater section. Too little air is indicated if the flame is yellow, lazy and smokey.
3. To adjust the air shutter, loosen air inlet shutter adjusting screw.
4. Open or close air shutter as necessary to obtain proper flame intensity.

5. After air shutter is adjusted for proper flame, tighten air shutter adjusting screw securely.

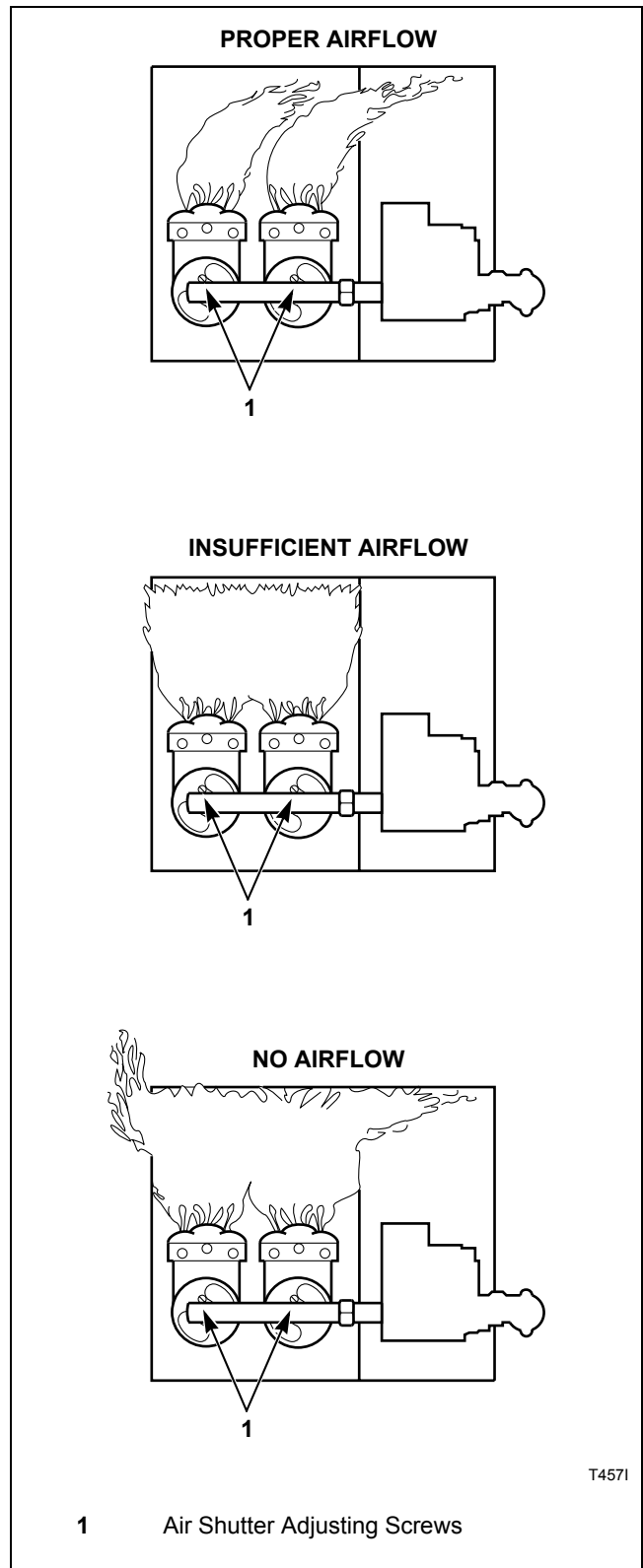



Figure 25

Adjustments

Airflow Switch

Gas and Electric Tumblers

| | |
|---|----------------|
|  | WARNING |
| <p>To reduce the risk of fire due to inadequate airflow, the airflow switch must be adjusted to operate per the instructions in this manual.</p> | |
| <small>W674</small> | |

The airflow switch (located on the rear of tumbler, *Figure 26*) is set at the factory for proper operation. However, if there is a problem with the switch, it should be adjusted as follows:

- Confirm exhaust duct and make-up air vents are properly sized and not obstructed. Refer to *Make-Up Air* and *Venting* sections.
- Confirm lint screen is clean and access panels are in place.
- Check operation of airflow switch and adjust as follows:

NOTE: Steam models do not have an airflow switch.

The airflow switch operation is controlled by the counterweight position in the shaft. Moving the counterweight either increases or decreases airflow switch sensitivity. The counterweight should be adjusted so the disc moves away from the cabinet when the lint panel is opened 1.5 inches (38.1 mm) with a full load. Adjust the airflow switch as follows:

1. Load the tumbler. This adjustment is much faster to make with one person opening lint panel in front and another adjusting the counterweight in the rear of tumbler.
2. Temporarily tape down the lint panel safety switch located behind the upper right corner of the lint panel.
3. Start the tumbler. Open the lint panel 1.5 inches (38.1 mm). The airflow disc should move away from the cabinet, opening the switch contacts and shutting off the heat system. This indicates proper operation and proper adjustment.
4. If switch is not opening as described in step 3, it should be adjusted so it is MORE sensitive. Depress the spring clip and move counterweight toward disc. Retest by opening lint panel and continue moving counterweight toward disc until switch operates as described in step 3.
5. If switch opens BEFORE lint panel is opened the proper distance, step 3, it should be adjusted so it is LESS sensitive. Depress the spring clip and move counterweight away from the disc. Retest by opening lint panel and continue moving counterweight away from disc until switch operates as described in step 3.

IMPORTANT: Remove tape from lint panel switch.

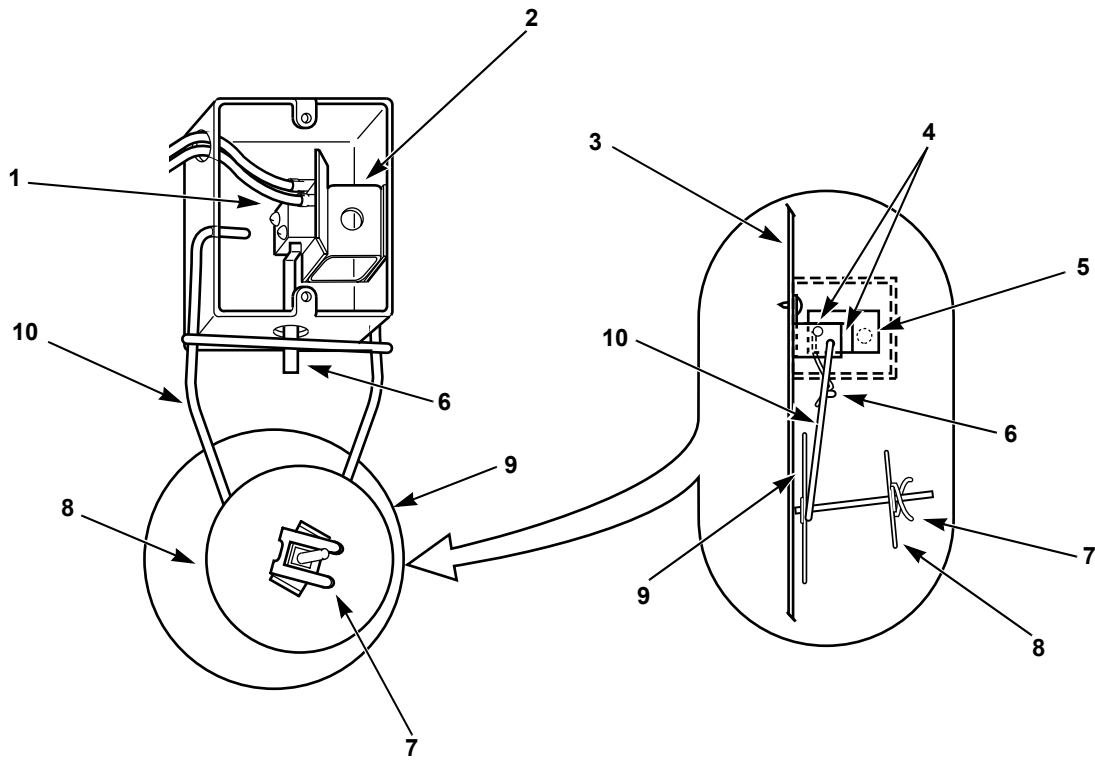

- | | | | |
|---|------------------------|----|----------------|
| 1 | Airflow Switch | 6 | Switch Lever |
| 2 | Mounting Bracket | 7 | Spring Clip |
| 3 | Rear Panel of Tumbler | 8 | Counterweight |
| 4 | Switch Mounting Screws | 9 | Disc |
| 5 | Screw | 10 | Vane Lever Arm |

T0411

Figure 26

Adjustments

Loading Door Switch

Loading door switch is factory preset, no field adjustment is necessary.

Loading Door Catch

The door catch must be adjusted to have sufficient tension to hold loading door closed against force of load tumbling against it. Proper adjustment is when 8 to 15 pounds (35.6 N – 66.7 N) pull is required to open door.

If adjustment is required, refer to *Figure 27* and proceed as follows:

To adjust, open door, loosen acorn nut and turn door strike screw in or out as required. Tighten acorn nut.

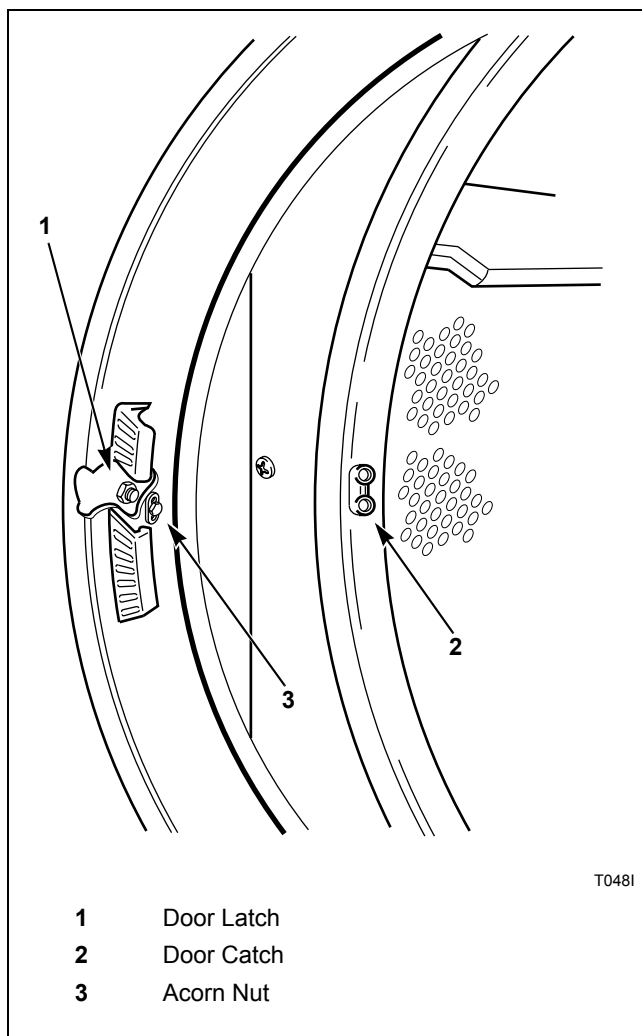

Figure 27

Drive Belt

Nonreversing Models

Refer to *Figure 28*.

Proper tension is when the drive V-belt can be depressed approximately 0.5 inch (13 mm) by applying light thumb pressure at a point midway between the sheave and motor pulley.

1. Remove guard from rear of tumbler.
2. To adjust belt tension, loosen idler housing bolts holding idler housing assembly to the guide rails.
3. Position housing assembly by turning adjusting bolt until proper belt tension is reached, then retighten idler housing bolts.
4. Replace the guard on rear of tumbler.

Reversing Models

Refer to *Figure 29*.

Proper tension is when the drive belt can be depressed approximately 0.5 inch (13 mm) by applying light thumb pressure (approximately 5 pounds [0.35 bar]) at a point midway between the sheave and motor pulley.

Proper tension is when each cylinder belt can be depressed approximately 0.19 inch (5 mm) by applying light thumb pressure (approximately 5 pounds [0.35 bar]) at a point midway between the sheave and the idler.

1. Remove guard from rear of tumbler.
2. To adjust cylinder belt tension, loosen idler housing bolts holding idler housing assembly to the guide rails.
3. Position housing assembly by turning adjusting bolt until proper belt tension is reached, then retighten idler housing bolts.

NOTE: Adjusting the cylinder belt tension will change the drive tension. Drive belt tension must also be adjusted.

4. Loosen the locking bolt.
5. Loosen the adjusting nut and use the adjusting screw to move the motor up or down.
6. Once proper belt tension is reached, retighten the adjusting nut and locking bolt.
7. Replace the guard on rear of tumbler.

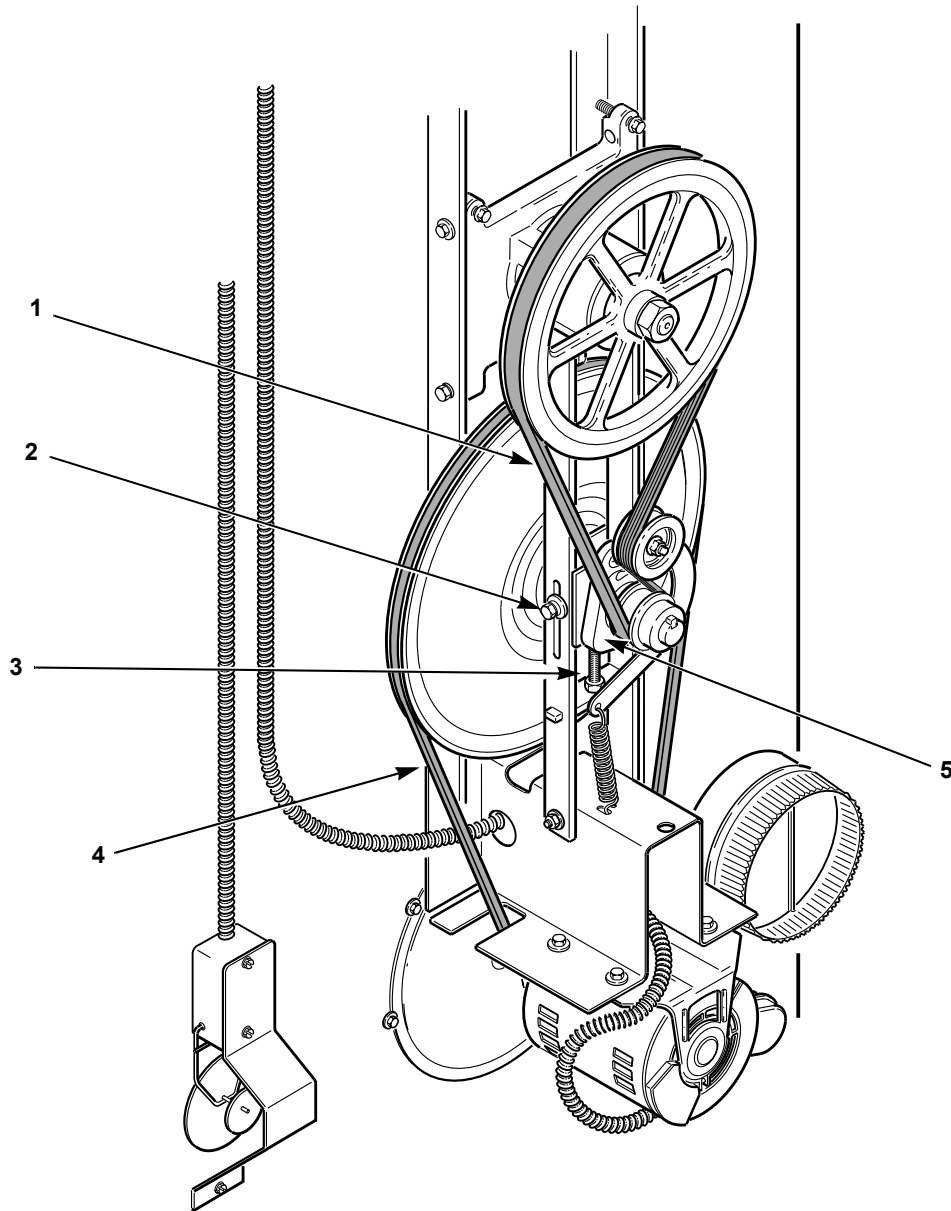

NONREVERSING MODELS

- | | |
|---|---|
| <p>1 Poly V-Belt (Self-Adjusting)</p> <p>2 Idler Housing Bolts (2)</p> <p>3 Adjusting Bolt</p> | <p>4 Drive V-Belt</p> <p>5 Idler Housing Assembly</p> |
|---|---|

TMB816N

Figure 28

Adjustments

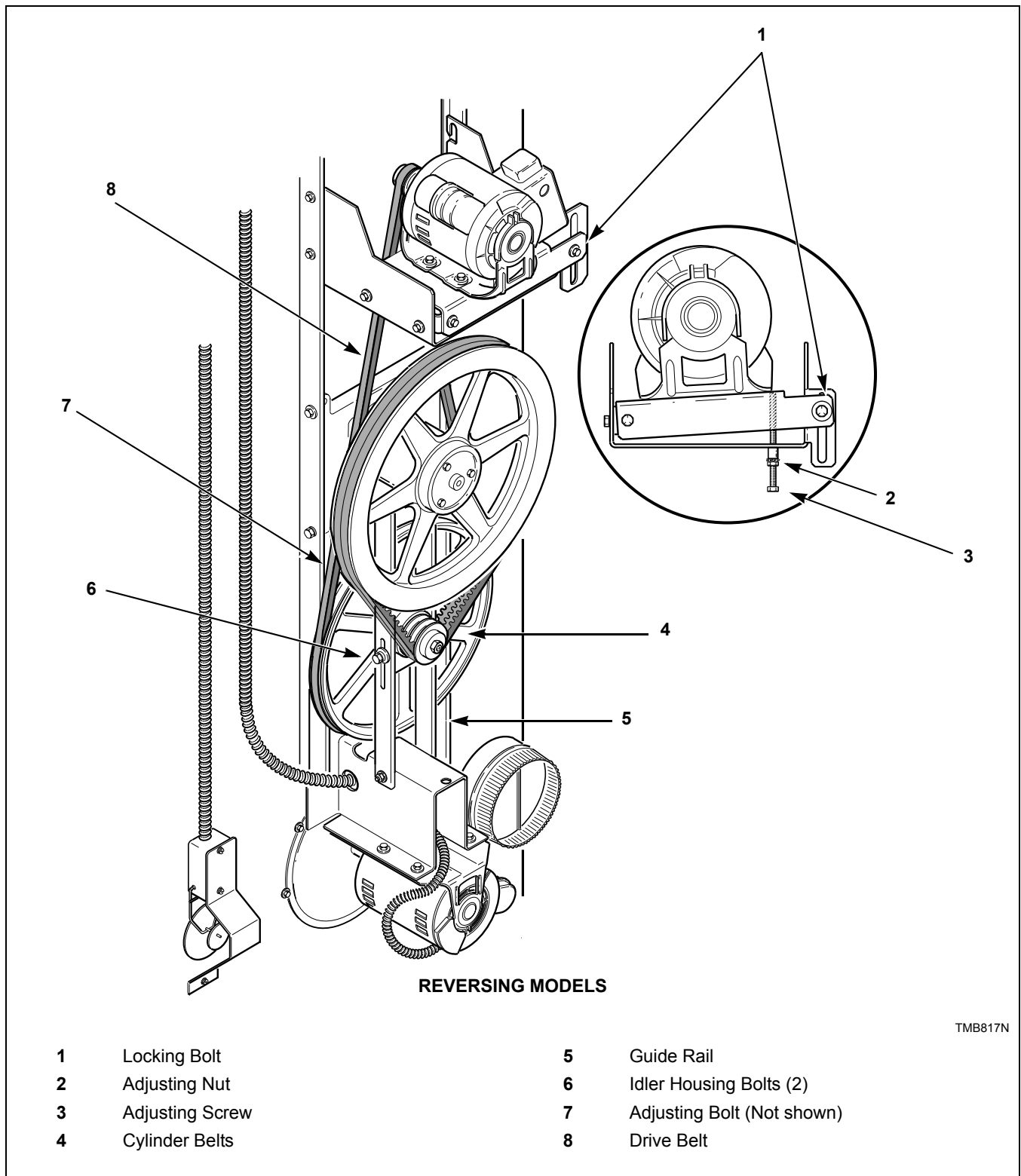

Figure 29

Removing Tumbler from Service

If the tumbler is to be removed from service, perform the following steps where applicable:

- Turn off electrical supply external to machine.
- Turn off electrical disconnect on machine.
- Turn off gas supply external to machine.
- Turn off manual gas shut-off valve on machine.
- Turn off steam supply external to machine.
- Remove all electric, gas and steam connections.