

MODEL: SMW999

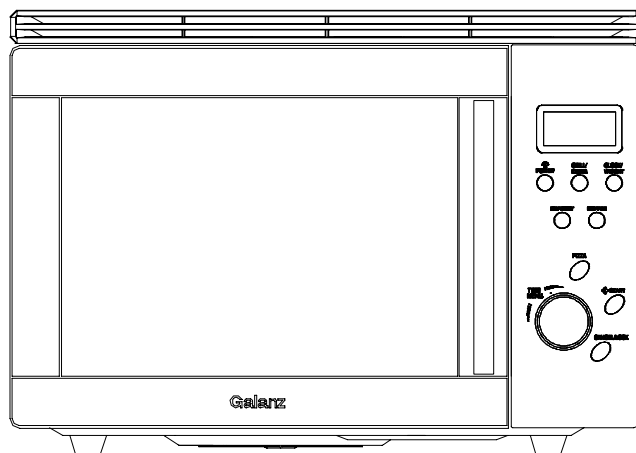

## Microwave Oven      Owner's Manual

Please read these instructions carefully before installing and operating the oven. Keep them for further reference.

Record in the space below the SERIAL NO. found on the nameplate on your oven and retain this information for future reference.

SERIAL NO.

## **PRECAUTIONS TO AVOID POSSIBLE EXPOSURE TO EXCESSIVE MICROWAVE ENERGY**

1. Do not attempt to operate this oven with the door open since open-door operation can result in harmful exposure to microwave energy. It is important not to defeat or tamper with the safety interlocks.
2. Do not place any object between the oven front face and the door or allow soil or cleaner residue to accumulate on sealing surfaces.
3. Do not operate the oven if it is damaged. It is particularly important that the oven door close properly and that there is no damage to the :
  - a. Door ( bent ),
  - b. Hinges and latches (broken or loosened).
  - c. Door seals and sealing surfaces.
4. The oven should not be adjusted or repaired by anyone except properly qualified service personnel.

## **CONTENT**

<i>PRECAUTIONS TO AVOID POSSIBLE EXPOSURE TO EXCESSIVE MICROWAVE ENERGY.....</i>	<i>1</i>
<i>IMPORTANT SAFETY INSTRUCTIONS.....</i>	<i>2</i>
<i>SPECIFICATION.....</i>	<i>3</i>
<i>INSTALLATION.....</i>	<i>3</i>
<i>GROUNDING INSTRUCTIONS.....</i>	<i>3</i>
<i>RADIO INTERFERENCE.....</i>	<i>4</i>
<i>MICROWAVE COOKING PRINCIPLES.....</i>	<i>4</i>
<i>UTENSILS GUIDE.....</i>	<i>2</i>
<i>PART NAMES.....</i>	<i>2</i>
<i>CONTROL PANEL.....</i>	<i>6</i>
<i>HOW TO SET THE OVEN CONTROLS.....</i>	<i>7</i>
<i>Setting The Digital Clock.....</i>	<i>7</i>
<i>Microwave Cooking.....</i>	<i>7</i>
<i>Grill.....</i>	<i>7</i>
<i>Combination Cooking.....</i>	<i>7</i>
<i>Pizza.....</i>	<i>7</i>
<i>Coffee/Milk.....</i>	<i>8</i>
<i>Auto Cook.....</i>	<i>8</i>
<i>Defrost.....</i>	<i>9</i>
<i>Express Cooking.....</i>	<i>9</i>
<i>Child Lock.....</i>	<i>9</i>
<i>Special Feature.....</i>	<i>9</i>
<i>CLEANING AND CARE.....</i>	<i>9</i>
<i>BEFORE YOU CALL FOR SERVICE.....</i>	<i>10</i>



---

---

## IMPORTANT SAFETY INSTRUCTIONS

When using electrical appliance basic safety precautions should be followed, including the following:

**WARNING:** To reduce the risk of burns, electric shock, fire, injury to persons or exposure to excessive microwave energy:

1. Read all instructions before using the appliance.
2. Use this appliance only for its intended use as described in this manual. Do not use corrosive chemicals or vapors in this appliance. This type of oven is specifically designed to heat, cook or dry food. It is not designed for industrial or laboratory use.
3. Do not operate the oven when empty.
4. Do not operate this appliance if it has a damaged cord or plug, if it is not working properly or if it has been damaged or dropped. If the supply cord is damaged, it must be replaced by the manufacturer or its service agent or a similarly qualified person in order to avoid a hazard
5. **WARNING:** Only allow children to use the oven without supervision when adequate instructions have been given so that the child is able to use the oven in a safe way and understands the hazards of improper use.
6. To reduce the risk of fire in the oven cavity:
  - a. When heating food in plastic or paper container, keep an eye on the oven due to the possibility of ignition.
  - b. Remove wire twist-ties from paper or plastic bags before placing bag in oven.
  - c. If smoke is observed, switch off or unplug the appliance and keep the door closed in order to stifle any flames.
  - d. Do not use the cavity for storage purposes. Do not leave paper products, cooking utensils or food in the cavity when not in use.
7. **WARNING:** Liquid or other food must not be heated in sealed containers since they are liable to explode.
8. Microwave heating of beverage can result in delayed eruptive boiling, therefore care has to be taken when handle the container.
9. Do not fry food in the oven. Hot oil can damage oven parts and utensils and even result in skin burns.
10. Eggs in their shell and whole hard-boiled eggs should not be heated in microwave ovens since they may explode even after microwave heating has ended.
11. Pierce foods with heavy skins such as potatoes, whole squash, apples and chestnuts before cooking.
12. The contents of feeding bottles and baby jars should be stirred or shaken and the temperature should be checked before serving in order to avoid burns.
13. Cooking utensils may become hot because of heat transferred from the heated food. Potholders may be needed to handle the utensil.
14. Utensils should be checked to ensure that they are suitable for use in microwave oven.
15. **WARNING:** It is hazardous for anyone other than a trained person to carry out any service or repair operation which involves the removal of any cover which gives protection against

---

---

exposure to microwave energy.

## SPECIFICATION

<b>Power Consumption:</b>	<b>120V~60Hz, 1350W(Microwave)</b>
	<b>120V, 1000W(Heater)</b>
<b>Rated Microwave Power Output:</b>	<b>900W</b>
<b>Operation Frequency:</b>	<b>2450MHz</b>
<b>Outside Dimensions:</b>	<b>305mm(H)×508mm(W)×400mm(D)</b>
<b>Oven Cavity Dimensions:</b>	<b>215mm(H)×350mm(W)×330mm(D)</b>
<b>Oven Capacity:</b>	<b>23Litres</b>
<b>Cooking Uniformity:</b>	<b>Turntable System{ Φ 314mm}</b>
<b>Net Weight:</b>	<b>Approx.16.5kg</b>

## INSTALLATION

1. Make sure that all the packing materials are removed from the inside of the door.
2. Check the oven for any damage, such as misaligned or bent door, damaged door seals and sealing surface, broken or loose door hinges and latches and dents inside the cavity or on the door. If there is any damage, do not operate the oven and contact qualified service personnel.
3. This microwave oven must be placed on a flat, stable surface to hold its weight and the heaviest food likely to be cooked in the oven.
4. Do not place the oven where heat, moisture, or high humidity are generated, or near combustible materials.
5. For correct operation, the oven must have sufficient airflow. Allow 20cm of space above the oven, 10cm at back and 5cm at both sides. Do not cover or block any openings on the appliance. Do not remove feet.
6. Do not operate the oven without glass tray, roller support, and shaft in their proper positions.
7. Make sure that the power supply cord is undamaged and does not run under the oven or over any hot or sharp surface.
8. The socket must be readily accessible so that it can be easily unplugged in an emergency.
9. Do not use the oven outdoors.

## GROUNDING INSTRUCTIONS

This appliance must be grounded. In the

event of an electrical short circuit, grounding

---

---

reduces risk of electric shock by providing an escape wire for the electric current.

**WARNING** Improper use of the grounding plug can result in a risk of electric shock.

#### ELECTRICAL REQUIREMENTS

The electrical requirements are a 120 volt 60 Hz, AC only, 20 amp. It is recommended that a separate circuit serving only the oven be provided. The oven is equipped with a 3-prong grounding plug. It must be plugged into a wall receptacle that is properly installed and grounded.

#### EXTENSION CORD

1. If it is necessary to use an extension cord, use only a 3-wire extension cord that has a 3-blade grounding plug and a 3-slot receptacle that will accept the plug on the

microwave oven. The marked rating of the extension cord shall be equal to or greater than the electrical rating of the appliance, or

2. Do not use an extension cord. If the power supply cord is too short, have a qualified electrician or serviceman install an outlet near the appliance.

#### Notes:

If you have any questions about the grounding or electrical instructions, consult a qualified electrician or service person.

Neither Sunbeam nor the dealer can accept any liability for damage to the oven or personal injury resulting from failure to observe the electrical connection procedures.

## RADIO INTERFERENCE

1. Operation of the microwave oven can cause interference to your radio, TV, or similar equipment.
2. When there is interference, it may be reduced or eliminated by taking the following measures:
  - a. Clean door and sealing surface of the oven.
  - b. Reorient the receiving antenna of

radio or television.

- c. Relocate the microwave oven with respect to the receiver.
- d. Move the microwave oven away from the receiver.
- e. Plug the microwave oven into a different outlet so that microwave oven and receiver are on different branch circuits.

## MICROWAVE COOKING PRINCIPLES

1. Arrange food carefully. Place thickest areas towards outside of dish.
2. Watch cooking time. Cook for the shortest amount of time indicated and add more as needed. Food severely overcooked can smoke or ignite.
3. Cover foods while cooking. Covers prevent spattering and help foods to cook evenly.

4. Turn foods over once during microwaving to speed cooking of such foods as chicken and hamburgers. Large items like roasts must be turned over at least once.
5. Rearrange foods such as meatballs halfway through cooking both from top to bottom and from the center of the dish to the outside.

## UTENSILS GUIDE

1. The ideal material for a microwave utensil is transparent to microwave, it allows energy to pass through the container and heat the food.
  2. Microwave cannot penetrate metal, so metal utensils or dishes with metallic trim should not be used.
  3. Do not use recycled paper products when microwave cooking, as they may contain small metal fragments which may cause sparks and/or fires.
  4. Round /oval dishes rather than square/oblong ones are recommend, as food in corners tends to overcook.
  5. Narrow strips of aluminum foil may be used to prevent overcooking of exposed areas. But be careful don't use too much and keep a distance of 1 inch (2.54cm) between foil and cavity.
- The list below is a general guide to help you select the correct utensils.

Cookware	Microwave	Grill	Combination Cooking
Heat-Resistant Glass	Yes	Yes	Yes
Non Heat-Resistant Glass	No	No	No
Heat-Resistant Ceramics	Yes	Yes	Yes
Microwave-Safe Plastic Dish	Yes	No	No
Kitchen Paper	Yes	No	No
Metal Tray	No	Yes	No
Metal Rack	No	Yes	No
Aluminum Foil & Foil Containers	No	Yes	No

## PART NAMES

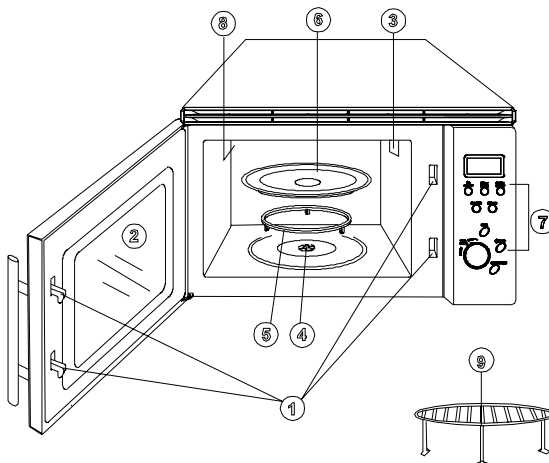

1. Door Safety Lock System
2. Oven Window
3. Oven Air Vent
4. Shaft
5. Roller Ring
6. Glass Tray
7. Control Panel
8. grill heater
9. metal rack

---

---

## CONTROL PANEL

### ● POWER

- ✕ Touch this pad a number of times to set microwave cooking power level.

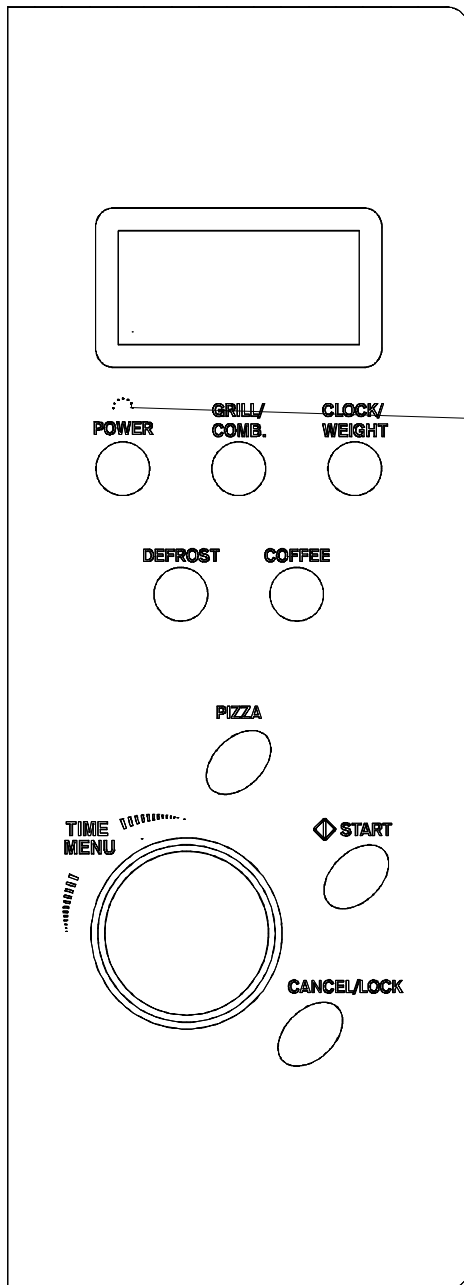

### ● GRILL/COMB.

- ✕ Press once or twice to broil or cook with combined microwave and grill power setting.

### ● CLOCK/WEIGHT

- ✕ Press and hold down to set the digital clock.
- ✕ Press a number of times to indicate food weight.

### ● START

- ✕ Press to start a cooking program.
- ✕ Simply touch it a number of times to start the oven quickly at full power.

### ● CANCEL/LOCK

- ✕ Press to cancel setting or reset the oven before setting a cooking program.
- ✕ Press once to temporarily stop cooking, or twice to cancel cooking altogether.
- ✕ Press and hold down to set or release child lock.

### ● TIME/MENU

- ✕ Turn the dial to set the oven clock time or input cooking time.
- ✕ Turn the timer/menu dial to indicate the type of food you want to cook by weight

### ● PIZZA

- ✕ Instant settings to bake pizza

### ● DEFROST

- ✕ Touch to defrost food by entering defrosting time.

### ● COFFEE/MILK

- ✕ Instant settings to heat coffee or milk

---

---

# HOW TO SET THE OVEN CONTROLS

---

Each time a button is pressed, a beep will sound to acknowledge the press.

## Setting The Digital Clock

When the oven is first plugged in, the display shows "1:01", you can set the clock time now or later. To start setting the clock time, press and hold down ADJUST/CLCOK button, then you can choose to set the clock time in 12-hour or 24-hour cycle.

FOR EXAMPLE: Suppose you want to set the oven clock time to 8:30.

1. Press and hold down the CLOCK/WEIGHT button until 12 H appears (press it once again to set it in 24 Hour cycle).
2. Turn TIME/MENU to set 8 o'clock.
3. Press CLOCK/WEIGHT. button.
4. Turn TIME/MENU to set 30 min.
5. Press CLOCK/WEIGHT. to confirm the setting.

## Microwave Cooking

For microwave cooking, just press the POWER pad a number of times to select a cooking power level, and then use the TIME/MENU dial to set a desired cooking time. The longest cooking time is 60 minutes.

Select power level by pressing the POWER button.

PRESS POWER BUTTON	COOKING POWER	Description
Once	100%	HIGH
Twice	80%	MEDIUM HIGH
3 times	60%	MEDIUM
4 times	40%	DEFROST
5 times	20%	LOW
6 times	0	COOL

For example, suppose you want to cook for 1 minute at 60% of microwave power.

1. Press POWER button 3 times.
2. Turn TIME/MENU to 1:00.
3. Press START button.

Note: once the cooking starts, you can add to or reduce cooking time by rotating the TIME/MENU knob.

## Grill

The longest cooking time is 60 minutes. The grill cooking is particularly useful for thin slices of meat, steaks, chops, kebabs, sausages or piece of chicken. It is also suitable for hot sandwiches and au gratin dishes.

For example, suppose you want to grill for 12 minutes.

1. Press GRILL/COMBI button once.
2. Turn the TIME/MENU to 12:00.
3. Press START button.

## Combination Cooking

The longest cooking time is 60 minutes which is divided between microwave and grill cooking. It is best used to cook foods such as fish, potatoes or au gratin, as well as puddings, omelettes, baked potatoes and poultry.

FOR EXAMPLE: Suppose you want to set combination cooking for 25 minutes.

1. Press GRILL/COMB. button twice.
2. Turn TIME/MENU to 25:00.
3. Press START button.

## Pizza

Press this button once to cook a piece of pizza weighing about 350g. The cooking time and power is automatically set. After you press the START button, the oven starts cooking.



Beeps can be heard at the end of the cooking; now you open the door and check the doneness of the food. If it's not quite satisfactory, close the door and press START up to 5 times to add to cooking time in 2 minutes increments.

One cup	once
Two cup	twice
three cup	thrice

The cooking time and power is automatically set. After you press the START button, the oven starts cooking.

Note: never cook liquids in sealed container, and always handle with extreme care of microwave boiled liquids.

### Coffee/Milk

Press this button up to 3 times to cook coffee or milk of varied quantity, which, if measured in normal size cup, is up to 3 cups.

Quantity	Press COFFEE/MILK pad
----------	-----------------------

### Auto Cook

For food or the following cooking mode, it is not necessary to program the duration and the cooking power. It is sufficient to indicate the type of food that you wish to cook as well as the weight of this food. In order to do this, turn the TIME/MENU dial to select a category of food/cooking mode. then press the CLOCK/WEIGHT button a number of times to indicate the number of servings or weight of food to be cooked. The oven begins cooking once the START button is engaged.

For example, to cook 450g of potato.

1. Rotate TIME/MENU until the display shows Auto Cook Code 4.
2. Press the CLOCK/WEIGHT pad three times to indicate food weight 450g.
3. Press START button.

### Auto Cook Code/Menu

Code	Food/cooking mode	Press CLOCK/WEIGHT dial to indicate weight of food
1	Popcorn	Weight parameters are used to determine the time needed to do the job. As you press the CLOCK/WEIGHT button, a number of pre-set weight parameters display, when it comes up of the right figure which matches the weight of the food you have placed into the oven, push the START button.
2	Spaghetti	
3	Reheat	
4	Potato	
5	Bread	
6	Vegetable	
7	Beef	
8	Chicken	

Please note: The result of Auto Cook depends on a number of factors such as the shape of food, and personal taste as to the doneness of food.

For some food, at the middle of cooking time, you may need to open the door and check its doneness or turn food over to obtain uniform cooking; But be careful to handle with care of very hot

---

---

food in the oven. To resume cooking, just close the door, the oven will cook for the remaining time.

### **Defrost**

The oven can be used to defrost meat, poultry, and seafood.

FOR EXAMPLE: Suppose you want to defrost 600g of shrimp.

1. Press DEFROST once.
2. Turn the TIME/MENU dial to indicate defrosting time.
3. Press START button.

Note: once the defrosting starts, you can add to or reduce defrosting time by rotating the TIME/MENU knob.

### **Express Cooking**

The oven will operate at HIGH power (100% power output) for EXPRESS cooking program.

To use this feature, press START button a number of times to specify cooking time, the oven will start immediately.

COOKING TIME	PRES START BUTTON
0:30	once
1:00	twice
1:30	thrice
...	...

For example, to set the oven to cook for 2

minutes using this feature:.

- ※ Press CANCEL/LOCK button.
- ※ Press START button 4 times, the oven starts working immediately at full power.

### **Child Lock**

Use to prevent unsupervised operation of the oven by little children. The CHILD LOCK indicator will show up on display screen, and the oven can not be operated while the CHILD LOCK is set.

To set the CHILD LOCK: Press and hold the CANCEL/LOCK button for 3 seconds, a beep sounds and LOCK indicator lights.

To cancel the CHILD LOCK: Press and hold the CANCEL/LOCK button for 3 seconds until lock indicator on display goes off.

### **Special Feature**

#### **AUTO REMINDER**

After a cooking or defrosting program has completed, the oven will automatically continue to sound three beeps every two minutes until the oven door is opened or the CANCEL/LOCK button is pressed.

## **CLEANING AND CARE**

1. Turn off the oven and remove the power plug from the wall socket before cleaning.
2. Keep the inside of the oven clean. When food splatters or spilled liquids adhere to oven walls, wipe with a damp cloth. Mild detergent may be used if the oven gets very dirty. Avoid the use of spray and other harsh cleaners as they may stain, streak or dull the door surface.
3. The outside surfaces should be cleaned with a damp cloth. To prevent damage to the operating parts inside the oven, water should not be allowed to seep into the ventilation openings.

- 
- 
4. Wipe the door and window on both sides, the door seals and adjacent parts frequently with a damp cloth to remove any spills or splatters. Do not use abrasive cleaner.
  5. Do not allow the control panel to become wet. Clean with a soft, damp cloth. When cleaning the control panel, leave oven door open to prevent oven from accidentally turning on.
  6. If steam accumulates inside or around the outside of the oven door, wipe with a soft cloth. This may occur when the microwave oven is operated under high humidity conditions. In such case, it is normal.
  7. It is occasionally necessary to remove the glass tray for cleaning. Wash the tray in warm sudsy water or in a dishwasher.
  8. The roller ring and oven floor should be cleaned regularly to avoid excessive noise. Simply wipe the bottom surface of the oven with mild detergent. The roller ring may be washed in mild sudsy water or dishwasher. When removing the roller ring from cavity floor for cleaning, be sure to replace in the proper position.
  9. Remove odors from your oven by combining a cup of water with the juice and skin of one lemon in a deep microwaveable bowl, microwave for 5 minutes. Wipe thoroughly and dry with a soft cloth.
  10. When it becomes necessary to replace the oven light, please consult a dealer to have it replaced.

## **BEFORE YOU CALL FOR SERVICE**

### IF THE OVEN FAILS TO OPERATE

1. Check to ensure that the oven is plugged in securely. If it is not, remove the plug from the outlet, wait 10 seconds, and plug it in again securely.
2. Check for a blown circuit fuse or a tripped main circuit breaker. If these seem to be operating properly, test the outlet with another appliance.
3. Check to ensure that the control panel is programmed correctly and the timer is set.
4. Check to ensure that the door is securely closed engaging the door safety lock system. Otherwise, the microwave energy will not flow into the oven.

IF NONE OF THE ABOVE RECTIFY THE SITUATION, THEN CONTACT A QUALIFIED TECHNICIAN. DO NOT TRY TO ADJUST OR REPAIR THE OVEN YOURSELF.