



**INSTRUCTION MANUAL / MANUAL DE INSTRUCCIONES  
PORTABLE AIR CONDITIONER  
AIRE ACONDICIONADO PORTATIL**

**Model Number / N° de Modelo : PAC12000**



**CAUTION:**

**BEFORE USE, PLEASE READ AND FOLLOW ALL SAFETY RULES AND OPERATING INSTRUCTIONS.**

La sección en español empieza en la página 19.

Avanti has a policy of continuous improvement on its products and reserves the right to change materials and specifications without notice.

---

**Avanti Products, A Division of the Mackle Co., Inc.  
P.O. Box 520604 - Miami, Florida 33152  
[www.avantiproducts.com](http://www.avantiproducts.com)**

---

## TABLE OF CONTENTS

Help Us Help You	3
Parts and Features	4
Important Safety Instructions	5
Tips Before Installing Your Air Conditioner	5
Installation Instructions	5
Window Installation Kit	6
Electrical Connection	8
Operating Your Air Conditioner	9
Control Panel Key Pad	9
Remote Control Structure and Operation	11
Battery Operation	12
Care and Maintenance	13
Cleaning the Air Filter	13
Drainage	13
Draining Condensed Water Step by Step	14
End of Season Care	14
Problems with Your Air Conditioner	15
Troubleshooting Guide	15
Service for Your Air Conditioner	16
Avanti Products Customer Services	16
Your Avanti Products Warranty	17
Wiring Diagram	18
Instrucciones en Español	19 - 28
Registration Information and Registration Form	29

---

## HELP US HELP YOU

### **Read this guide carefully.**

It is intended to help you operate and maintain your new air conditioner properly.

Keep it handy to answer your questions. If you don't understand something or you need more assistance, please call:

**Avanti Customer Service  
800-220-5570**

Keep proof of original purchase date (such as your sales slip) with this guide to establish the warranty period.

### **Write down the model and serial numbers.**

You'll find them on the rating plate located on the right side of the unit.

Please write these numbers here:

\_\_\_\_\_   
Date of Purchase

\_\_\_\_\_   
Model Number

\_\_\_\_\_   
Serial Number

Use these numbers in any correspondence or service calls concerning your air conditioner.

If you received a damaged air conditioner, immediately contact the dealer (or builder) that sold you the air conditioner.

Save time and money. Before you call for service, check the Troubleshooting Guide. It lists causes of minor operating problems that you can correct yourself.

---

## **IF YOU NEED SERVICE**

We're proud of our service and want you to be pleased. If for some reason you are not happy with the service you receive, here are some steps to follow for assistance.

FIRST, contact the people who serviced your air conditioner. Explain why you are not pleased. In most cases, this will solve the problem.

NEXT, if you are still not pleased, write all the details, including your telephone number, and send it to:

**Customer Service  
Avanti Products  
10880 NW 30 Street  
Miami, FL 33172 USA**

## PARTS AND FEATURES

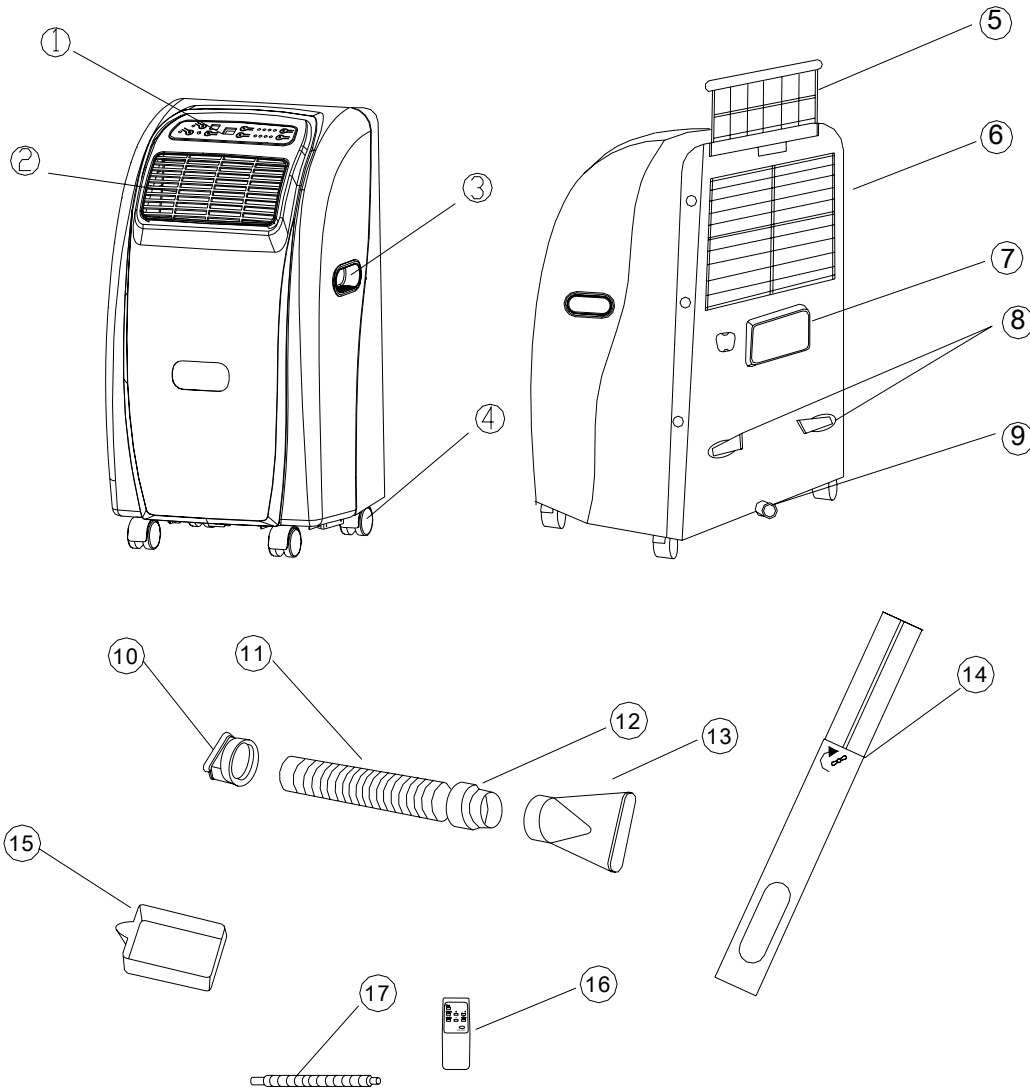

1	Control Panel	10	Inner Air Exhaust Adaptor for Air Exhaust Duct (11)
2	Cool Air Outlet	11	Exhaust Air Duct
3	Carry Handles (Both sides)	12	Exhaust Air Duct Adapter
4	Casters	13	Window Installation Adapter
5	Air Filter	14	Window Installation Kit
6	Air inlet grille	15	Water Drain Tray
7	Exhaust Air Outlet	16	Remote Control
8	Cord Hanger	17	Water drain hose
9	Drain Hole		

## IMPORTANT SAFETY INSTRUCTIONS

<b>⚡ELECTRIC SHOCK HAZARD⚡</b>	To reduce the risk of fire, electrical shock, or injury when using your air conditioner, follow these basic precautions:
<p><b>Read all instructions before using the air conditioner.</b></p> <ul style="list-style-type: none"><li>• If the air conditioner has a serial plate rating of 115 Volts ~ AC, and up to 7.5 amps, the unit may be on a fuse or circuit breaker with other devices. However, the maximum amps of all devices on that fuse or circuit breaker cannot exceed the amps or the fuse of circuit breaker.</li><li>• If the air conditioner has a serial plate rating of 115 Volts ~ AC, and greater than 7.5 amps, it must have its own fuse or circuit breaker, and no other device or unit should be operated on the fuse or circuit breaker.</li><li>• To avoid the possibility of personal injury, disconnect power to the unit before installing or servicing.</li></ul> <p style="text-align: center;">-Save these instructions-</p>	

### TIPS BEFORE INSTALLING YOUR AIR CONDITIONER

**Your room air conditioner unit is designed to be highly efficient and save energy. Follow these recommendations for greater efficiency:**

- Select temperature setting that suits your comfort needs and leave the temperature at that chosen setting.
- The filter is very efficient in removing airborne particles. Keep air filter clean. The filter should be cleaned once a month. More frequent cleaning may be necessary depending on outdoor and indoor air quality.
- Use drapes, curtains, or shades to keep direct sunlight from heating your room, but DO NOT obstruct the air conditioner. Allow air to circulate around the unit without obstructions.
- Start your air conditioner before the room temperature air becomes hot and uncomfortable. This avoids an initial period of discomfort while the unit is cooling off the room.
- When room temperature is cool enough, use HIGH, MED or LOW FAN only. This will circulate the air, providing some cooling comfort, and utilizes less electricity than when operating on a cooling setting.
- Save the shipping carton and packing materials for future storage or transport of the unit. Please check the contents of hardware kit against the corresponding model PARTS AND FEATURES check list, prior to installation of the unit.

### INSTALLATION INSTRUCTIONS

- The unit should be installed on a level surface.
- Select a suitable location with easy access to an electrical outlet.
- Leave at least 12" (30.50cm) clearance between your unit and the nearest object, including walls.
- Install the flexible exhaust hose and the adjustable window slider kit provided (**see Fig 1**).
- Plug unit into an 115V/60Hz grounded electrical outlet.

**NOTE:** Use drapes, curtains or shades to keep direct sunshine from penetrating the room but do not allow them to obstruct the air flow around the unit.

## WINDOW KIT INSTALLATION

### Installation Accessories (See Fig 1):

Flexible exhaust hose with adapters - (N° 10, 11 and 12 on PARTS AND FEATURES)	- 3 piece(s)
Window slider kit adapter - (N° 13 on PARTS AND FEATURES)	- 1 piece(s)
Adjustable window slider kit - (N° 14 on PARTS AND FEATURES)	- 1 piece(s)

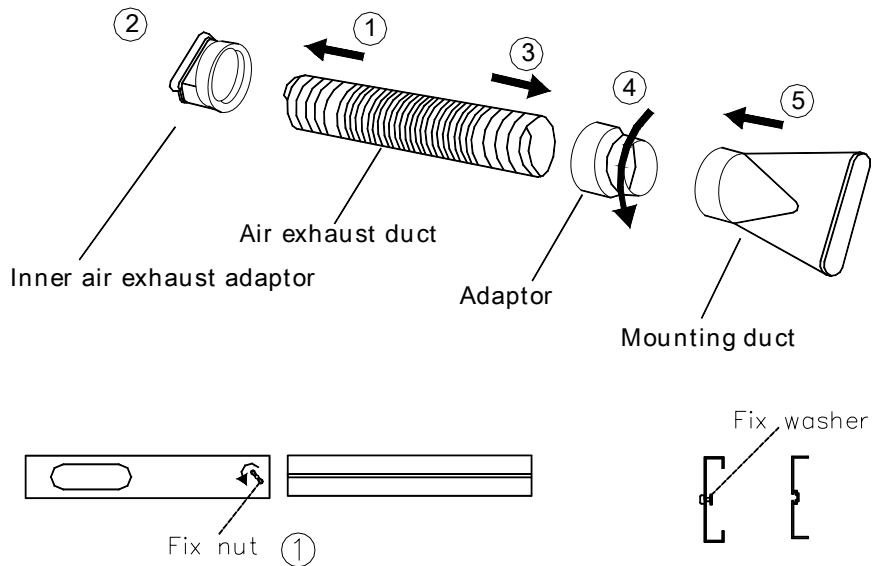

**Fig 1**

**These Accessories MUST be installed at all times when the unit is operating under the cooling modes: AUTO or COOL.**

### Flexible Exhaust Hose with Adapters:

The unit operates more efficiently if the exhaust hose is shorter.

Length:

Minimum: 21.6" (55 cm)

Maximum: 59" (150 cm)

The EXHAUST HOSE does not have to be installed during operation of the FAN mode.

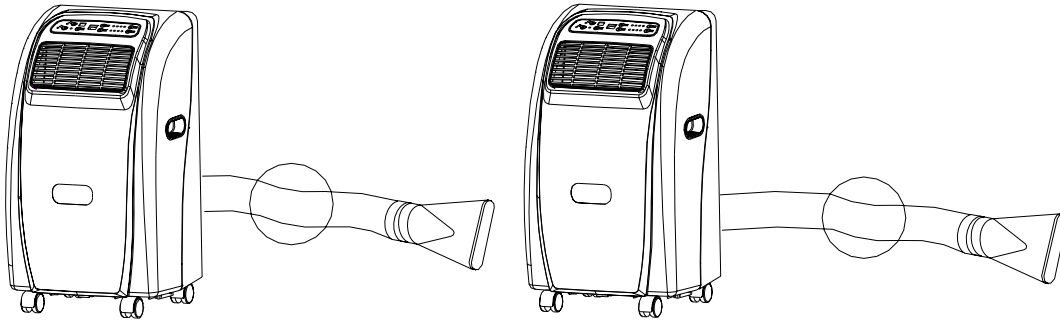

**Window KIT Installation (See Fig 2):**

? How to insert the window slider adaptor to the window slider kit?

- Hold the window slider adaptor close to the hole of the window slider.(Pic.1)
- Firmly insert the two clippers of the adaptor into the slider hole.( Pic.2)
- Press hard to insert the other two clippers inside the hole, make sure all four clippers are full inserted (Pic.3)



Pic. 1



Pic. 2



Pic. 3

The Kit provided has been designed to fit most standard vertical and horizontal window applications. Please refer to figures 2 for minimum and maximum window openings. For certain type of windows you may have to modify the window slider kit. The WINDOW KIT does not have to be installed during operation of the FAN mode.

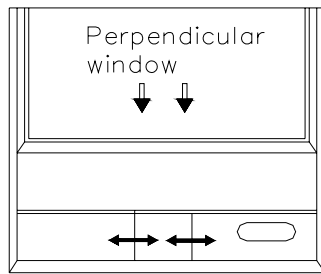

Perpendicular window  
Window Slider Kit  
Minimum: 58cm  
Maximum: 162cm

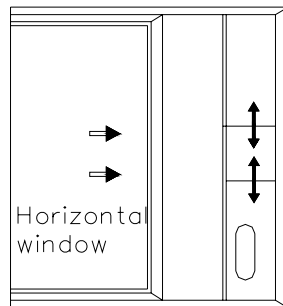
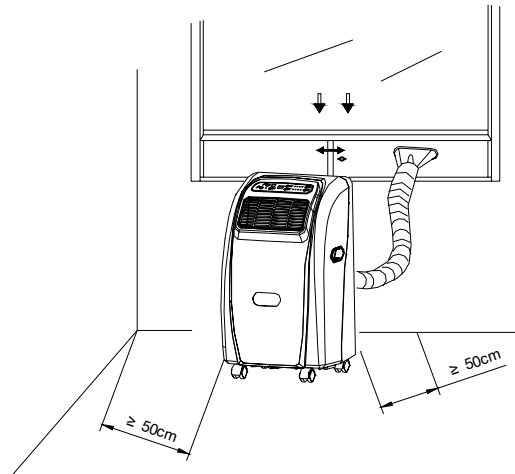

Horizontal window  
Window Slider Kit  
Minimum: 58cm  
Maximum: 162cm

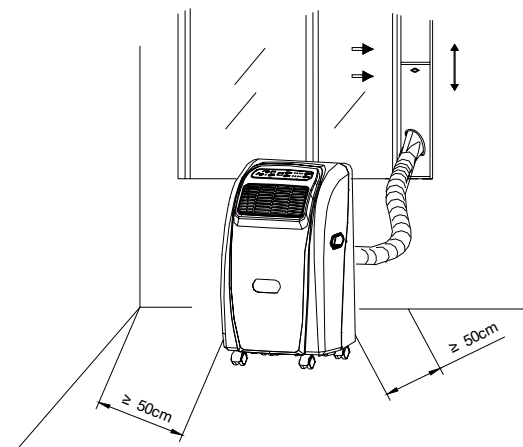

Fig. 2

## ELECTRICAL CONNECTION

### ⚡WARNING⚡

Improper use of the grounded plug can result in the risk of electrical shock. If the power cord is damaged, have it replaced by an authorized Avanti Products service center.

All wiring must comply with local and national electrical codes and must be installed by a qualified electrician.

Check available power supply and resolve any wiring problems **BEFORE** installing and operating this unit.

This air conditioner should be properly grounded for your safety. The power cord of this air conditioner is equipped with a three-prong plug which mates with standard three prong wall outlets to minimize the possibility of electrical shock. If you are not sure whether your wall outlet is properly grounded, please consult a qualified electrician.

Do not, under any circumstances, cut or remove the third ground prong from the power cord supplied.

This air conditioner requires a standard 115/120 Volt-AC/60Hz electrical outlet with three-prong ground.

Never unplug the air conditioner by pulling the power cord. Always grip the plug firmly and pull straight out from the receptacle.

Do not use plug adapters or an extension cord with this appliance. If the power cord is too short, have a qualified electrician or service technician install an outlet near the appliance.



## OPERATING YOUR AIR CONDITIONER

### CONTROL PANEL KEY PAD

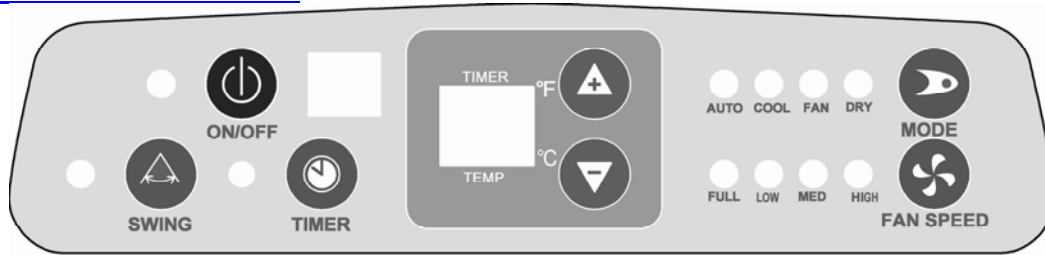

#### **ON/OFF**

To turn power ON, press ON/OFF key once. The unit will run at AUTO mode (default). LCD window will display the AUTO icon. To turn power OFF, press it again.

#### **TEMPERATURE**

Press (▲ and ▼) keys to select a suitable temperature setting. The temperature selected will be displayed in the LCD window.

Temperature settings are adjustable between 59° - 88°F / 15° - 31°C.

The defaulted displayed temperature will be in Celsius degrees. To switch to Fahrenheit, push the (▲ and ▼) keys at the same time and hold for 3 seconds.

The switching on the remote control is the same as on the Control Panel.

#### **FAN SPEED**

Press FAN SPEED key and the speed sequence will be displayed to right of the LCD window. You can choose between: LO - MED - HIGH

#### **MODE**

Each time you press this button, a mode is selected in the following sequence:

**AUTO – COOL – FAN – DRY**

The running mode selected will be displayed the right of the LCD window.

#### **SWING Mode**

Press the SWING key to activate the multi direction air louver.

Press the SWING key once and the louver will continuously move from left to right. Press the Swing key again and the louver will stop in its current position.

#### **TIMER ON/OFF (Dual Action Timer)**

Press the TIMER key to set desired auto-timer settings sequences of 30 minutes, from ½ hour to 12 hours.

“AUTO-OFF” Function:

When the unit is ON and running in the selected mode, you can select the amount of time you would like the unit to run before turning itself OFF.

Every time you press the TIMER key, the AUTO OFF time will be displayed in the LCD window. To disable, press the timer button until 12:00 displays and then press once again, the length of operation is now displayed.

“AUTO-ON” Function:

When the unit is OFF, you can select the amount of time to pass before the unit will turn it self ON and resume the mode and temperature previously set.

The same applies to AUTO ON time. When unit is on power OFF position, press the TIMER key to set the AUTO ON time.

## OPERATING YOUR AIR CONDITIONER

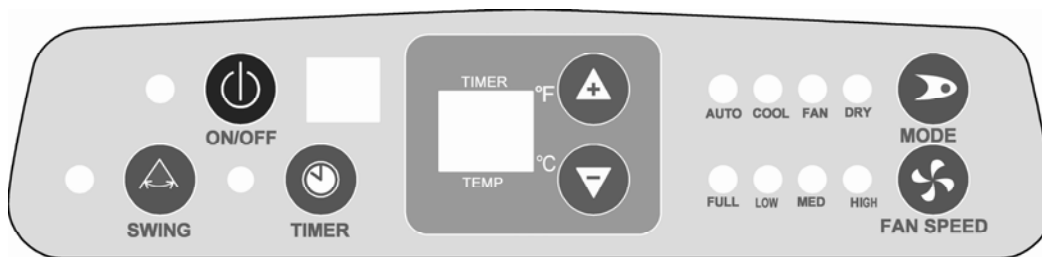

### **AUTO Display**

When this sequence is selected, after pressing the MODE button, the corresponding signal indicator is lit. In this mode, your unit will logically choose a desired room temperature. If the temperature is not comfortable for you, the desired MODE can be selected manually.

### **COOL Display**

When this sequence is selected after pressing the MODE button, the corresponding signal indicator is lit. You should set the desired room temperature and speed of the fan manually.

### **TEMPERATURE Display**

Shows the selected temperature.

### **FAN Display**

When this sequence is selected, after pressing the MODE button, the signal indicator is lit. Then select a speed for the fan manually. Under this mode you cannot select the TEMPERATURE.

### **DEHUMIDIFIER Display**

When this sequence is selected after pressing the mode button, the corresponding signal indicator is lit.

Under this mode, you cannot select a fan speed or adjust the temperature since the fan motor operates at a pre-set fan speed.

## REMOTE CONTROL STRUCTURE AND OPERATION

The remote control uses 2 alkaline dry batteries (AAA 1.5V).

To install the batteries, slide back the cover and mount them according to the signs (+ and -) shown on the rear compartment.

### **NOTE:**

If you plan not to use the control for several weeks, remove the batteries. When replacing the batteries, do not mix old and new.

Replace the batteries when the transmission indicator light fails to appear.

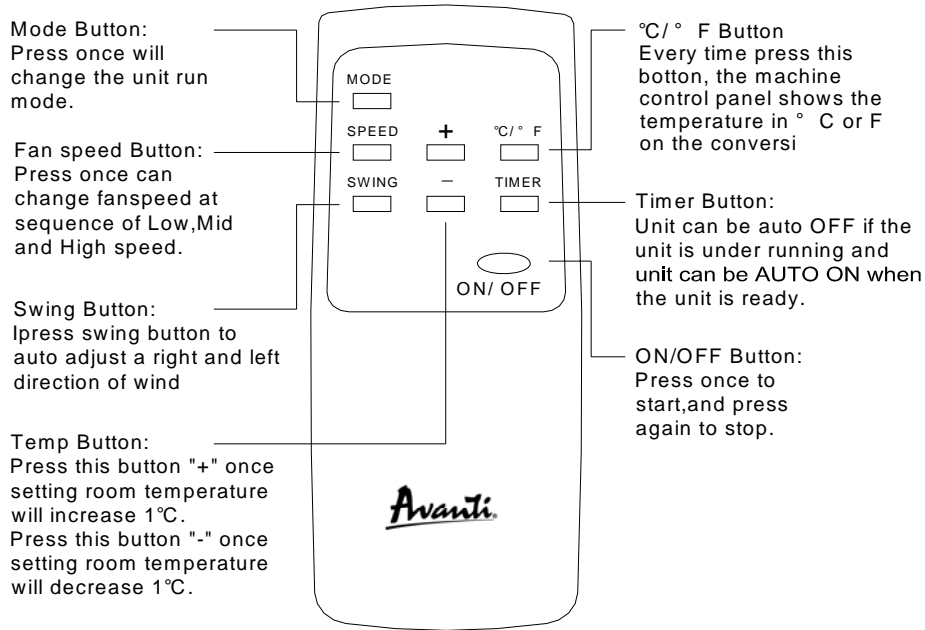

### **Remote control (Auto mode)**

The compressor and fan motor will cycle on or off according to the room temperature to keep the room comfortable.

### **Remote control (cooling mode)**

Setting temperature range 15-31°C ( 59-88°F ) .

When the room temperature sensor's temperature is higher than the set temperature, the compressor starts to run.

When the room temperature sensor's temperature is lower than the set temperature, the compressor stops and fan operates at original speed.

### **Remote control (Fan mode)**

Fan mode: the compressor and lower fan motor stop, upper fan run at set speed, in this case, temperature setting becomes invalid.

### **Remote control (Dehumidifying mode)**

Dehumidifying mode: the compressor and lower fan are running and the upper fan is running at low speed.

## Battery Operation

Please notice the (+) Positive and (-) Negative points while mounting the batteries. We suggest using alkaline batteries.

If the batteries need to be replaced or thrown away, the batteries must be removed and disposed of in accordance with the current laws as it may present an environmental hazard.

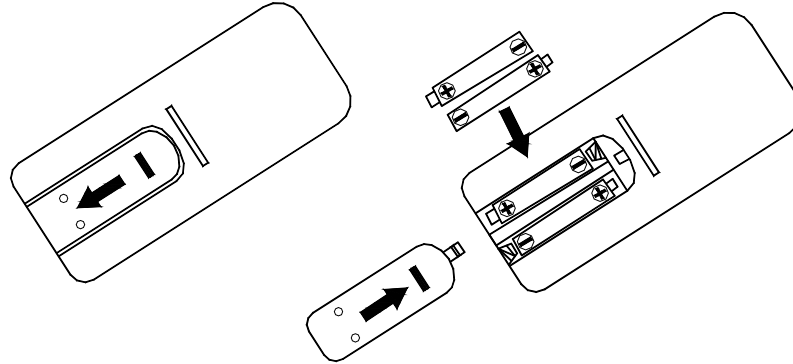

Remote control inserting the batteries

1. Slide the cover as shown in figure.
2. Insert two new non-rechargeable batteries, being careful to place them in the correct position(+) and (-).
3. Put the cover back on, letting it slide into its original position.

## CARE AND MAINTENANCE

- When servicing the air conditioner, be sure to turn your appliance OFF and disconnect the power cord from the electrical outlet.
- Do not use gasoline, benzine, thinner or other chemicals on the air conditioner as these substances may cause damage to the paint finish and deformation of plastic parts.
- Never attempt to pour water directly to the front of the unit as this will cause deterioration of the electrical insulation.

### Cleaning the Air Filter

If the air filter becomes clogged with dust, airflow is obstructed and reduces efficiency. The air filter should be cleaned once a month. More frequent cleaning may be necessary depending on outdoor and indoor air quality.

The air filter is located behind the air inlet located in the back. To remove the air filter, take out the Phillips head screw located above the Air Inlet Grille and slide the air filter out (see Fig. 3). To reinstall the air filter, reverse the above procedure.

Fig. 3

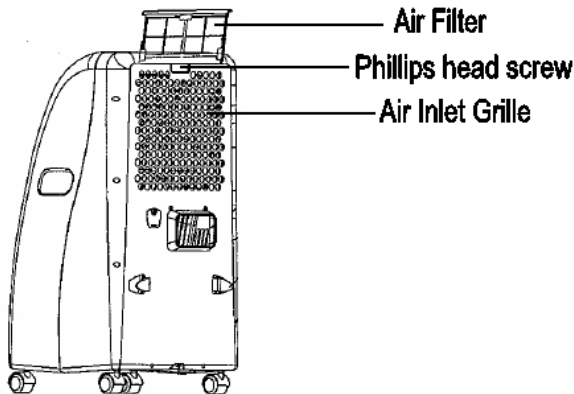

Remove dust clogged in the filter by tapping it or vacuum clean it. Wash the filter well with lukewarm water below 40°C (104°F) while rubbing lightly: To get better results, wash it with soapy water or a neutral cleaning agent. Rinse the filter well using clean water, and then dry completely.

### Drainage

When the air conditioner is running at AUTO, COOL, DEHUMIDIFIER modes, condensed water will drain into the inner water tray. If the tray gets full, a buzzer will sound 20 times and the RED LED FULL indicator light will turn on. At the same time, the cooling system stops running automatically. Three minutes later, the fan will also stop.

To restart the cooling system, please follow these steps:

## Draining condensed water step by step

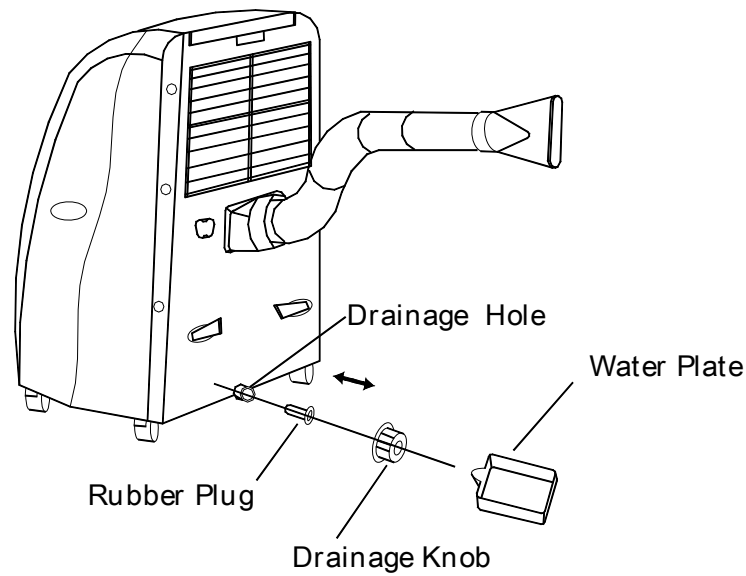

1. Turn off the unit.
2. Place the Water Drain Tray underneath the Drainage Pipe.
3. Remove the Drainage Knob and the Rubber Plug, then condensed water will automatically flow out.
4. If the Water Drain Tray gets full, push the Rubber Plug back to the Drainage Pipe and empty the tray.
5. Repeat steps 2, 3 and 4, until all the condensed water in the unit is drained.
6. Put back the Rubber Plug and the Drainage Knob to the Drainage Pipe.
7. Restart the unit

### End-of-Season Care

- Operate the air conditioner, in FAN mode alone, for half a day to dry out the inside of the unit.
- Turn off power and remove plug from wall socket.
- Clean filter.
- Drain.
- Store in dry location.

## PROBLEMS WITH YOUR AIR CONDITIONER?

You can solve many common air conditioner problems easily, saving you the cost of a possible service call. Try the suggestions below to see if you can solve the problem before calling the service.

### TROUBLESHOOTING GUIDE

PROBLEM	POSSIBLE CAUSE	SUGGESTED SOLUTION
Air conditioner does not operate.	No power to the unit.	Check connection of power cord to power source. The circuit breaker tripped or a blown fuse. Set OPERATION knob to position other than "OFF".
Inefficient or no cooling.	Dirty air filter.  Inappropriate capacity for application.  Blocked airflow.  Power interruption, settings change too quickly, or compressor overload tripped.	Clean or replace air filter. Check with dealer to determine proper unit capacity for application. Remove obstruction from grille or outdoor louvers. Let fan run to restart compressor (in approximately 10 minutes.)
Noisy unit.	Loose parts. Inadequate support.	Tighten loose parts. Provide additional support to unit.
Odors.	Formation of mold, mildew, or algae on wet surfaces.	Remove drain plug and drain base pan. Replace drain plug. Clean unit thoroughly.
Water dripping outside.	Condensation run-off is normal during hot and humid weather.	Add flexible tubing to redirect water flow.
Water dripping inside.	Unit is not properly angled to allow water to drain outside.	Unit must be installed on an angle for proper condensation run-off. Check the unit and make adjustments.
Ice or frost build-up.	Low outside temperature.          Unit air filter is dirty.	When outdoor temperature is approximately 65°F or below, frost may form when unit is in cooling mode. Switch unit to FAN (only) operation until frost melts. Remove and clean filter.

**NOTE:**

If circuit breaker is tripped repeatedly, or fuse is blown more than once, contact a qualified technician.

## **SERVICE FOR YOUR AIR CONDITIONER**

We are proud of our customer service organization and the network of professional service technicians that provide service on your Avanti air conditioner. With the purchase of your Avanti air conditioner, you can be confident that if you ever need additional information or assistance, the Avanti Products Customer Service Team will be here for you. Just call us toll-free.

### **AVANTI PRODUCTS CUSTOMER SERVICES**

Product Information 800-323-5029	Whatever your questions are about our products, help is available.
Part Orders 800-220-5570	You may order parts and accessories that will be delivered directly to your home, by personal check, money order, Master Card, or Visa.
In-Home Repair Service 800-220-5570	An Avanti Products authorized service center will provide expert repair service, scheduled at a time that is convenient for you. Our trained service staff knows your air conditioner inside and out.



<p><b>YOUR Avanti Products WARRANTY</b></p> <p><i>Within the 48 contiguous United States and Puerto Rico.</i></p>	<p><b>Staple your sales receipt here. Proof of original purchase date is needed to obtain service under warranty.</b></p>
---	---

**WHAT IS COVERED**

**FULL ONE-YEAR PARTS AND LABOR WARRANTY**

During the first year after the date of original purchase, Avanti Products will, through its authorized servicers, repair or replace any parts which are defective in material or workmanship due to normal use. Ready access to the air conditioner is the responsibility of the owner.

**LIMITED FIVE YEAR SEALED SYSTEM WARRANTY**

In addition to the full one year parts and labor warranty described above, Avanti Products will, through its authorized servicers, exchange sealed system parts (consisting of the compressor, evaporator, condenser, and interconnecting tubing) during the second through fifth years, from the original date of purchase, providing the parts are defective in material or workmanship. Transportation, handling, and labor costs to diagnose, repair or replace such defective parts are not covered by this limited parts warranty and are the owner's responsibility.

**WHAT IS NOT COVERED**

Avanti's warranty, as with most other appliance manufacturers' warranties, is based on time not usage. The above warranty does not cover failure to function caused by damage to the unit while in your possession (other than damage caused by defect or malfunction), or by it improper installation, or be unreasonable use of the unit, including without limitation, failure to provide reasonable and necessary maintenance or to follow the written Installation and Operating Instructions. If the unit is put to commercial, business, rental, or other use or application other than for consumer use, we make no warranties, express or implied, including but not limited to, any implied warranty of merchantability of fitness for particular use or purpose. The above warranty does not cover repairs performed by unauthorized servicers, service calls that do not involve defects in material or workmanship such as customer education, or proper installation, replacement of house fuses or resetting circuit breakers. Service calls that are related to external problems, such as abuse, misuse, inadequate electrical power, accidents, fire, floods, or acts of God.

The remedies provided for in the above express warranty are the sole and exclusive remedies; therefore, no other express warranties are made. All implied warranties, including but not limited to any implied warranty of merchantability or fitness for a particular use or purpose, are limited in duration to one year from the date of original purchase. In no event shall Avanti Products be liable for indirect, incidental, or consequential damages, even if advised in advance of the possibility of such damages, no warranties, express or implied, are made to any buyer upon resale.

Some states do not allow limitations on how long an implied warranty lasts or do not allow the exclusion or limitation of incidental or consequential damages, so the above limitations or exclusions may not apply to you. This warranty gives you specific legal rights, and you may also have other rights, which may vary from state to state.

# WIRING DIAGRAM

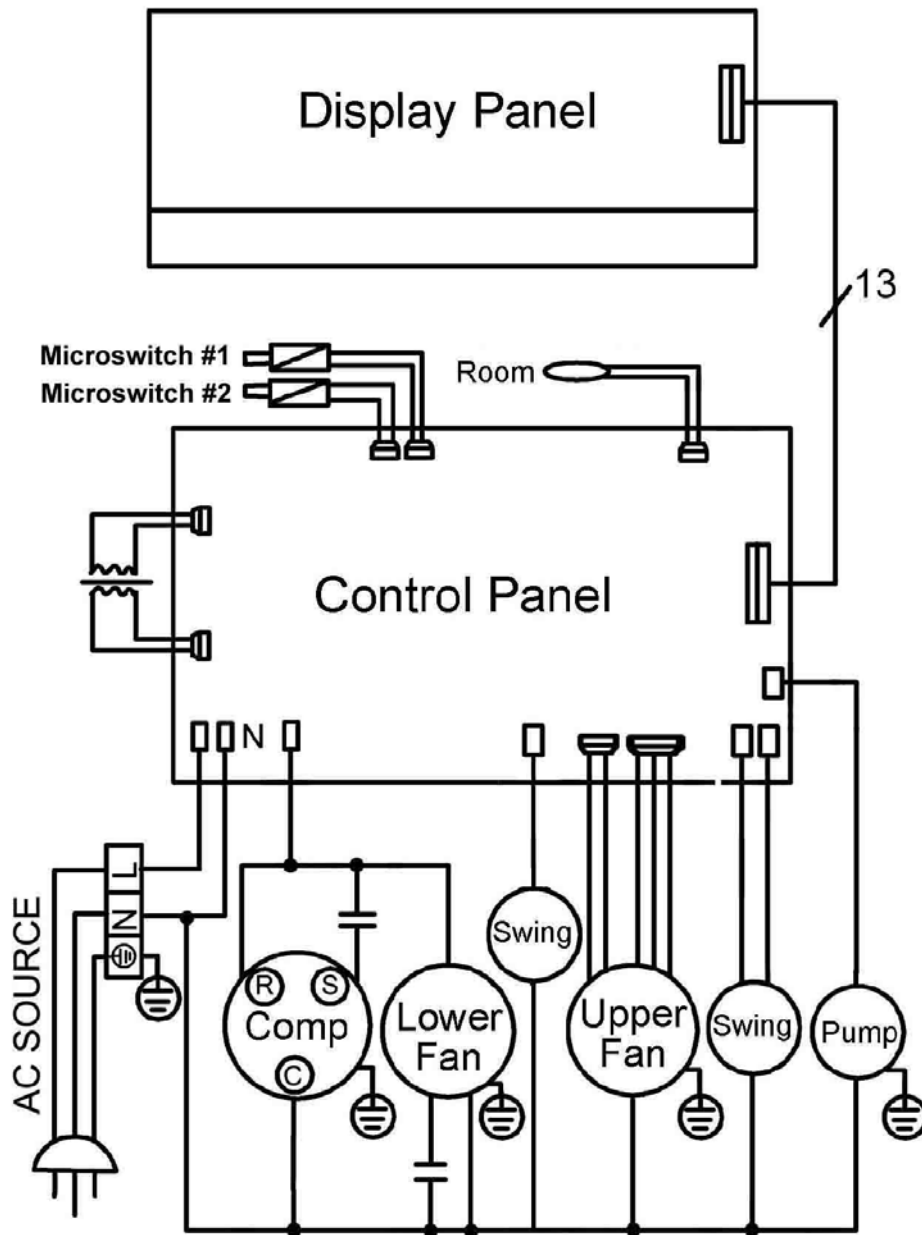

# INSTRUCCIONES EN ESPAÑOL

## PIEZAS Y CARACTERÍSTICAS

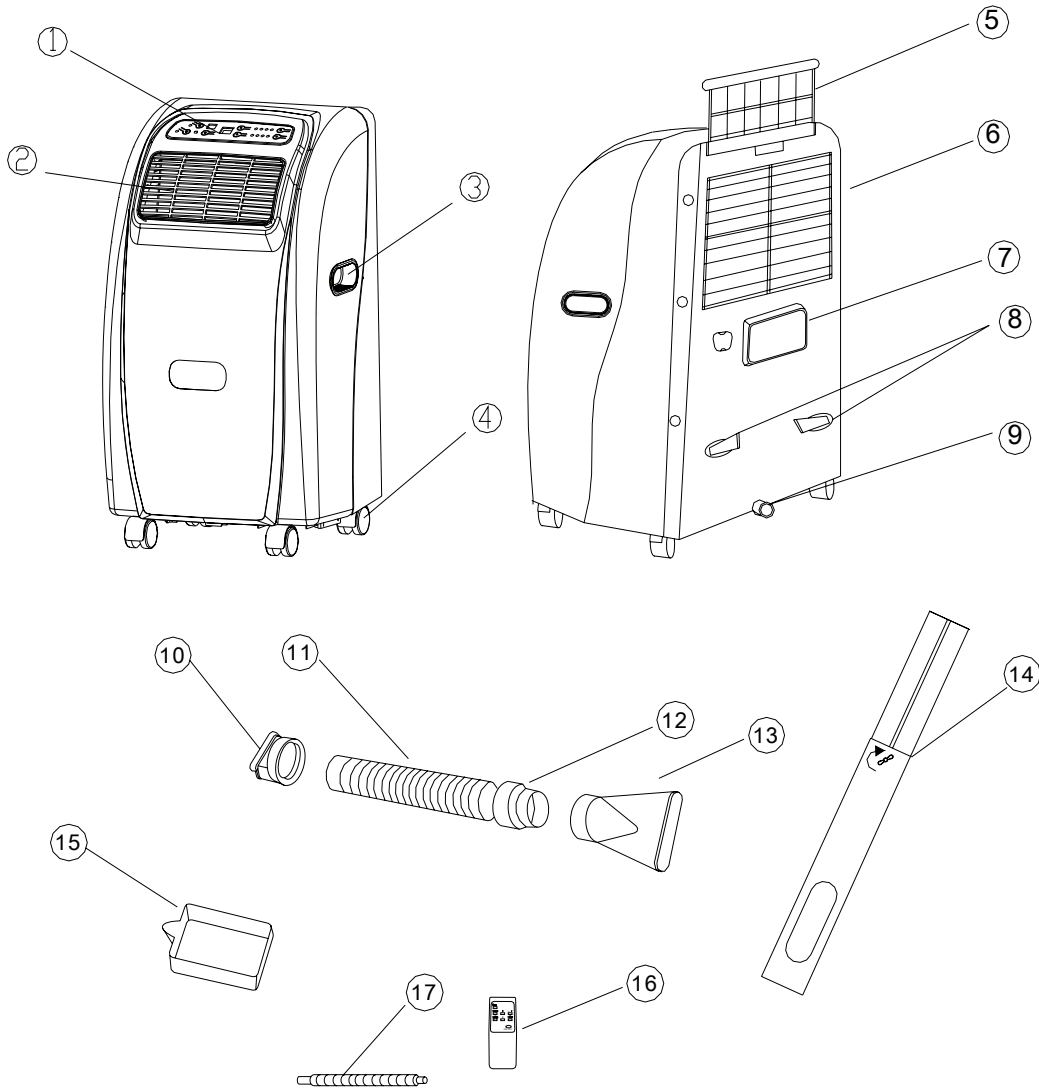

1	Control de temperature	10	Adaptador para el escape de aire
2	Salida de aire frio	11	Manguera para el escape de aire
3	Manijas (ambos lados)	12	Adaptador terminal para la manguera del escape de aire
4	Ruedas	13	Adaptador terminal para la manguera del escape de aire al kit para la instalación en la ventana
5	Filtro de aire	14	Kit para la instalación del adaptador de ventana
6	Parilla del ingreso de aire	15	Bandeja para el agua de drenaje
7	Escape de aire	16	Control remoto
8	Colgador del cable eléctrico	17	Manguera de desagüe
9	Tube de drenaje		

## KIT PARA LA INSTALACIÓN DEL ADAPTADOR DE VENTANAS

### Accesorios de Instalación (vea la Fig 1):

Manguera de Escape de Aire y Adaptadores - (Nº 10, 11 y 12 en PIEZAS Y CARACTERÍSTICAS)	- 3 piezas
Kit Ajustable para Ventanas - (Nº 15 en PIEZAS Y CARACTERÍSTICAS)	- 1 pieza
Adaptador del Kit Ajustable para Ventanas - (Nº 15 en PIEZAS Y CARACTERÍSTICAS)	- 1 pieza

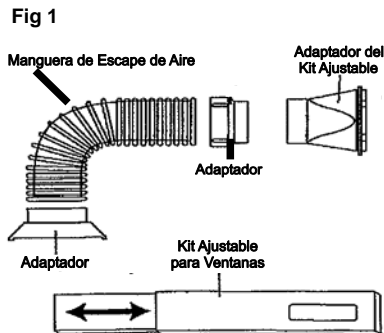

**Estos accesorios deberán estar instalados cuando la unidad esté operando bajo el modo: AUTOMÁTICO, ENFRIAR o DESHUMEDECEDOR**

### Manguera de Escape de Aire:

Estas son las extensiones mínimas y máximas de su Manguera de Escape de Aire:

Mínima: 55cm (21.6")

Máxima: 150cm (59")

Su unidad operará más eficientemente si la Manguera de Escape de aire es más corta.

**No es necesario que la Manguera de Escape Aire esté instalada mientras su equipo esté operando bajo el modo VENTILADOR**

### Instalación del Adaptador de Ventanas (Vea la Fig 2 y 2a):

El Adaptador de Ventanas provisto con su unidad ha sido diseñado para ser instalado en la mayoría de ventanas horizontales y verticales.

Por favor, sírvase verificar la extensión mínima y máxima del Adaptador, para ventanas horizontales y verticales en la figura 2 y 2a.

Para algunos tipos de ventana, tal vez deba modificar su Adaptador de Ventana.

**No es necesario que el Adaptador de Ventana esté instalado mientras su equipo esté operando bajo el modo: VENTILADOR.**

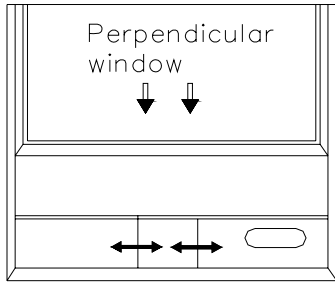

Window Slider Kit  
 Minimum: 58cm  
 Maximum: 162cm

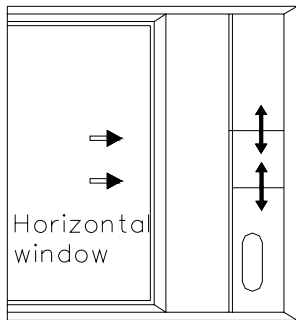
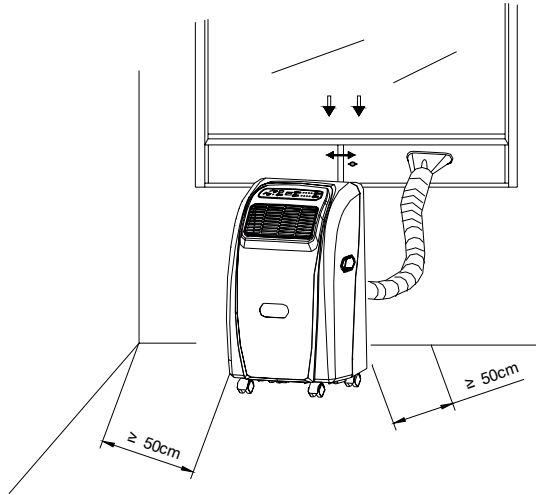

Window Slider Kit  
 Minimum: 58cm  
 Maximum: 162cm

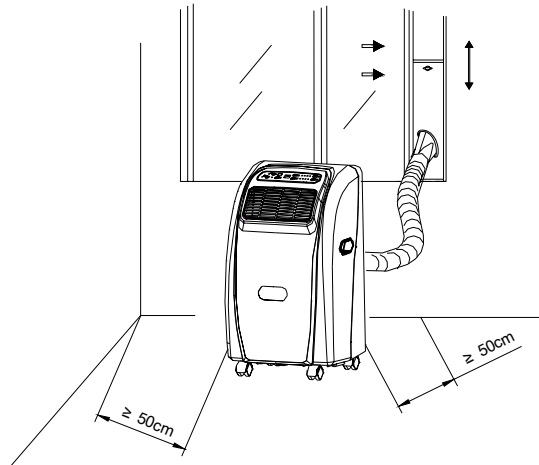

## CONEXIÓN ELÉCTRICA

### ⚡ Advertencia ⚡

El uso inapropiado de la conexión a tierra podría incrementar el riesgo de descarga eléctrica. Si el cable de electricidad está dañado, hágalo reemplazar en un centro de servicio de Avanti.

El sistema de cableado de su aire acondicionado deberá cumplir con todos los estatutos de acuerdo con los códigos locales y nacionales, además, deberá ser instalado por un electricista calificado.

Verifique la disponibilidad de fuentes eléctricas en donde vaya a instalar su unidad, resuelva cualquier problema referente a este aspecto **ANTES** de instalarla y operarla.

Por su seguridad, este aire acondicionado deberá contar con una conexión a tierra apropiada. El cable eléctrico de su unidad cuenta con un enchufe de tres puntos, el cual ha sido diseñado para ser usado con los enchufes de pared (con conexión a tierra) standard. De esta manera se reduce el riesgo de descarga eléctrica. Si tiene alguna pregunta respecto de la fuente eléctrica y/o la conexión a tierra, ésta deberá ser dirigida a un electricista certificado o a un centro de servicio autorizado de Avanti Products.

Bajo ninguna circunstancia, corte o quite el tercer punto (conexión a tierra) de su cable eléctrico.

Este aire acondicionado requiere una fuente de energía standard de 115/120 Volt-AC/60Hz, y un enchufe de pared con tres puntos (conexión a tierra).

Nunca desenchufe su equipo halando del cable eléctrico. Siempre sujete el enchufe de tres puntos y tire firmemente de él hasta sacarlo del enchufe de pared.

No use adaptadores o un cable de extensión. Si el cable eléctrico es muy corto, contáctese con un electricista calificado o un técnico de servicio para instalar un enchufe de pared cerca de su aire acondicionado.

## ¿CÓMO OPERA SU AIRE CONDICIONADO?

### PANEL DE CONTROL

#### TEMPERATURA

Presione los botones (▲ and ▼) para seleccionar una temperatura apropiada. La temperatura seleccionada será mostrada en la pantalla LCD.

Las temperaturas que puede escoger se encuentran entre los 59°F (15°C) y los 88°F (31°C).

La temperatura programada de fábrica estará representada en grados Fahrenheit. Si desea cambiar a grados Centígrados, presione simultáneamente los botones (▲ and ▼) por tres (3) segundos.

Para realizar el cambio en el control remoto, realice esta misma operación.

#### VELOCIDAD

Presione el botón **FAN SPEED** para aumentar la velocidad.

Podrá escoger entre: BAJO (**LO**) - MEDIO (**MED**) - ALTO (**HI**)

#### MODO

Cada vez que presione el botón **MODE**, cambiará el modo de operar de su aire acondicionado según la siguiente secuencia:

**AUTOMÁTICO – ENFRIAR – VENTILADOR – DESHUMEDECEDOR**

#### TEMPORIZADOR AUTOMÁTICO

Presione el botón **TIMER** para programar el encendido o apagado automático de su aire acondicionado.

Usted podrá escoger entre 30 min. y 12 horas. Cada vez que pulse el botón, el tiempo aumentará en

secuencias de 30 min., el nuevo tiempo programado aparecerá en la pantalla LCD  
Para desactivar esta función, presione hasta que aparezca **12:00**, entonces presiónelo una vez más. Ahora, la pantalla mostrará el tiempo que su equipo esta en funcionamiento.  
Esto aplica tanto para el apagado como para el encendido. Cuando su equipo este apagado, presione el botón **TIMER** para programar el encendido automático.

### **ENCENDIDO/APAGADO**

Para encender presione el botón **ON/OFF** una vez. Su unidad empezará a trabajar en el modo **AUTOMATICO**. Para apagar la unidad, presione el botón **ON/OFF** nuevamente.

## **¿COMO OPERA SU AIRE CONDICIONADO?**

### **AUTOMÁTICO (AUTO)**

Cada vez que seleccione este modo de operar, el bombillo correspondiente alumbrará. En este modo, la unidad escogerá, automáticamente, una temperatura para su habitación. Si ésta no es de su agrado, puede seleccionar otro modo de funcionamiento manualmente.

### **ENFRIAR (COOL)**

Cada vez que seleccione este modo de operar, el bombillo correspondiente alumbrará.  
En este caso, usted deberá programar la temperatura de la habitación y la velocidad del ventilador manualmente.

### **TEMPERATURA**

Muestra la temperatura seleccionada.

### **VENTILADOR (FAN)**

Cada vez que seleccione este modo de operar, el bombillo correspondiente alumbrará. En este modo, solo podrá seleccionar la velocidad del ventilador. NO podrá seleccionar una TEMPERATURA.

### **DESHUMIDIFICADOR (DEHUMIDIFIER)**

Cada vez que seleccione este modo de operar, el bombillo correspondiente alumbrará. Bajo este modo de operación, no podrá seleccionar la velocidad del ventilador o la temperatura (estos viene pre-programados de fábrica)  
En esta función, su aire condicionado extrae la humedad de su habitación.

### **REJILLAS DE VENTILACION OSCILANTES (SWING)**

Presione el botón marcado (SWING) para activar las rejillas de ventilación oscilantes..  
Presione el botón marcado (SWING) una vez, las rejillas de ventilación oscilarán de lado a lado para mejor circulación del aire. Presione el botón marcado (SWING) una vez más, las rejillas de ventilación se parará de oscilar en su presente posición..

### **Figura TIEMPO (TIME)**

Cuando la unidad esté encendida, la pantalla mostrará el tiempo que esta en funcionamiento. El tiempo va desde 00:01 minutos hasta 24:00 horas.

Cuando use la función **TIMER**, el tiempo programado aparecerá en la pantalla LCD.

## CONTROL REMOTO: ESTRUCTURA Y OPERACIÓN

El control remoto usa dos (2) baterías alcalinas secas (AAA 1.5V).

Para instalar las baterías, deslice la tapa que se encuentra en la parte posterior del control remoto. Póngalas en su lugar guiándose por los signos (+ y -) que aparecen en el compartimiento interior.

### **NOTA:**

Si no va usar el control remoto por algunas semanas, quite las baterías.

Cambie las baterías cuando, al operar el control remoto, el indicador de la señal de transmisión no aparezca.

Cuando cambie las baterías asegúrese de no mezclarlas con las viejas, esto reduciría el tiempo de duración de las nuevas.

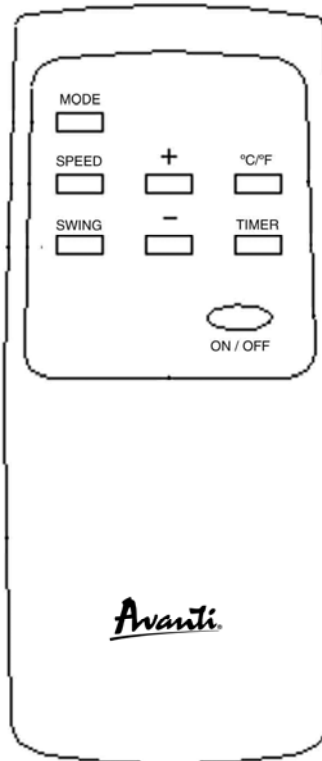

Para las funciones de los BOTONES, por favor diríjase a la sección PANEL DE CONTROL



## CUIDADO Y MANTENIMIENTO

- Cuando vaya a hacerle servicio a su aire acondicionado, asegúrese de apagarlo y desconectarlo del enchufe de pared.
- No use gasolina, bencina, tiner u otros químicos para limpiar su aire acondicionado, estas substancias podrían causar daños al acabado de la pintura y deformar las partes plásticas.
- Nunca intente verter agua directamente al frente de la unidad, esto deterioraría el aislamiento eléctrico.

### Limpiando el Filtro de Aire

Si el filtro de aire se obstruye con polvo, el flujo del aire lo hará también, reduciendo la eficiencia de su aire acondicionado. Para evitar esto, deberá limpiar el filtro de aire una vez al mes. Dependiendo de la calidad del aire, tanto interior como exterior, la frecuencia de la limpieza podría ser menor.

El filtro de aire está localizado detrás de la parrilla del ingreso de aire (en la parte posterior). Para sacar el filtro de aire, quite el tornillo que se encuentra en la zona superior de la parrilla empleando un desentornillador Phillips. Luego deslice el filtro de aire hacia arriba (vea la Fig. 3). Para reinstalarlo, invierta el procedimiento anterior.

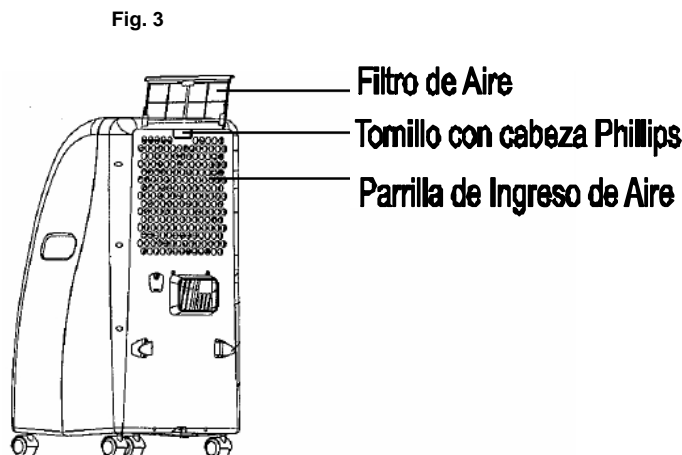

Quite el polvo del filtro golpeándolo suavemente o aspirándolo.

Lave bien el filtro con agua tibia, debajo de 40°C (104°F), mientras lo frota ligeramente: Para obtener mejores resultados, lávelo con agua jabonosa o un agente de limpieza neutral.

Asegúrese de enjuagar bien el filtro con agua limpia, luego séquelo completamente.

### Drenado

Mientras el aire acondicionado funciona en el modo AUTO, ENFRIAR, o DESHUMEDECEDOR el agua que se condensa, drenará en una bandeja interior. Si la bandeja se llena, una alarma sonará por 20 segundos y el mensaje "E4" aparecerá en la pantalla LCD. Al mismo tiempo, el sistema de enfriamiento dejará de funcionar. Tres minutos después, el ventilador también dejará de funcionar.

Para que el aire acondicionado vuelva a funcionar, realice los siguientes pasos:

## CUIDADO Y MANTENIMIENTO

### Drenando el agua condensada paso por paso

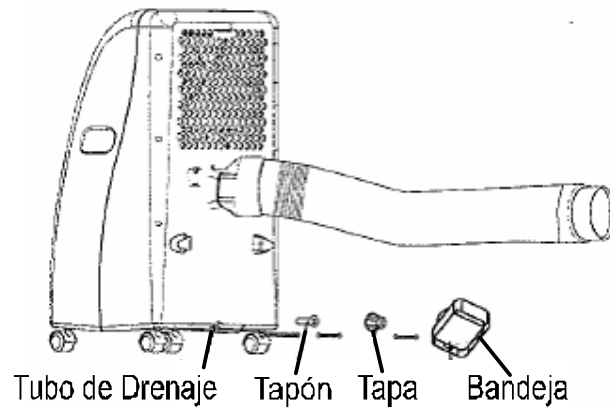

1. Apague la unidad.
2. Ponga la bandeja para el agua de drenado debajo del tubo de drenaje.
3. Quite la tapa de rosca y el tapón de jebe del tubo de drenaje. El agua de la bandeja interior circulará hacia fuera automáticamente.
4. Si la bandeja para el agua de drenado se llena, coloque nuevamente el tapón de jebe y la tapa de rosca.
5. Repita los pasos 2, 3 y 4, hasta que haya drenado toda el agua de la bandeja interior.
6. Coloque el tapón de jebe y la tapa de rosca en el tubo de drenaje.
7. Reinicie la unidad.

### Cuidado para el Fin de Temporada

- Opere la unidad solo bajo el modo VENTILADOR por medio día para secar totalmente el interior de su aire acondicionado.
- Apague el equipo y desconéctelo del enchufe de pared.
- Limpie el filtro de aire.
- Drene su máquina.
- Guárdela en un lugar seco.

## ¿PROBLEMAS CON SU AIRE CONDICIONADO?

Usted puede resolver fácilmente muchos problemas comunes de su aire acondicionado ahorrándole el costo de una posible llamada de servicio. Pruebe con las sugerencias aquí indicadas para ver cómo puede resolver sus problemas antes de realizar una llamada de servicio.

### GUÍA DE SOLUCIÓN DE PROBLEMAS

PROBLEMA	CAUSA POSIBLE	SOLUCIÓN SUGERIDA
El Aire Condicionado no funciona.	La unidad no tiene energía.	Verifique la conexión del cable eléctrico y el enchufe de pared. El interruptor se “disparó” o el fusible voló. Presione el botón ON/OFF.
No hay enfriamiento o no es suficiente.	Filtro de aire sucio. La capacidad de su equipo no es suficiente. El flujo de aire (ingreso o salida) está siendo bloqueado. La alimentación de energía no es constante, cambios en la programación de temperatura muy rápidos o el compresor está sobrecargado.	Limpie o reemplace el filtro de aire. Verifique con su distribuidor la capacidad apropiada para el uso de su unidad. Retire los elementos que obstruyen el ingreso o las salidas de aire. Deje que el ventilador corra por 10min para reiniciar el compresor (Modo AUTO o ENFRIAR)
Ruidos en la unidad.	Piezas sueltas. Soporte inadecuado.	Ajuste las piezas sueltas. Proporcione un soporte adicional a la unidad.
Olores.	Formación de moho o algas en las superficies mojadas.	Drene la unidad y limpie todos los elementos (tubo de drenaje y bandejas de agua).
Goteo en la parte externa.	Esto es normal cuando el ambiente está caliente o húmedo.	Adicione un tubo flexible para redireccionar el exceso de agua.
Goteo en la parte interna.	El ángulo de ubicación de la unidad no es el indicado para permitir que el agua drene hacia afuera.	La unidad se debe instalar en un ángulo que permita drenar el agua apropiadamente. Haga los ajustes necesarios para que pueda realizar esta acción sin problemas.
Acumulación de hielo.	La temperatura de la habitación es muy baja.  El filtro de aire está sucio.	Cuando la temperatura exterior sea de 65°F (o menor), se podrá formar hielo si la unidad está en AUTO o ENFRIAR. Cambie al modo VENTILADOR hasta que el hielo se derrita. Limpie el filtro de aire.

**NOTA:**

Si el interruptor se “dispara” repetidamente o el fusible “vuela” más de una vez, póngase en contacto con un técnico calificado.

## SERVICIO DE MANTENIMIENTO

Estamos orgullosos de la organización de nuestro centro de servicio al cliente y de los técnicos profesionales que proveen servicio a su aire acondicionado portátil Avanti. Cuando compra un producto Avanti, usted puede estar seguro que si alguna vez necesita información o asistencia, nuestro equipo de servicio al cliente de Avanti Products estará para ayudarlo.

### SERVICIO AL CLIENTE DE AVANTI PRODUCTS

Información de producto 800-323-5029	Cualquiera sea su pregunta sobre nuestros productos, la ayuda está disponible.
Pedido de piezas 800-220-5570	Usted puede ordenar piezas y accesorios que serán enviados directamente a su casa con cargo a un cheque personal, órdenes de dinero, Visa o Mastercard.
Servicio de reparación a domicilio 800-220-5570	Un centro de servicio autorizado de Avanti Products le proveerá de un servicio de reparación experimentado, éste será programado a la hora que le sea más conveniente. Nuestro equipo de servicio está totalmente entrenado y conoce su aire acondicionado por dentro y fuera.

## REGISTRATION INFORMATION

Thank you for purchasing this fine Avanti product. Please fill out this form and return it within 100 days of purchase to receive these important benefits to the following address:

**Avanti Products, A Division of The Mackle Co., Inc.  
P.O. Box 520604 - Miami, Florida 33152 USA**

➤ **PROTECT YOUR PRODUCT:**

We will keep the model number and date of purchase of your new Avanti product on file to help you refer to this information in the event of an insurance claim such as fire or theft.

➤ **PROMOTE BETTER PRODUCTS:**

We value your input. Your responses will help us develop products designed to best meet your future needs.

----- (DETACH HERE) -----

### AVANTI REGISTRATION FORM

NAME \_\_\_\_\_

MODEL # \_\_\_\_\_ SERIAL # \_\_\_\_\_

ADDRESS \_\_\_\_\_

DATE PURCHASED \_\_\_\_\_ STORE/DEALER NAME \_\_\_\_\_

CITY \_\_\_\_\_ STATE \_\_\_\_\_ ZIP \_\_\_\_\_

OCCUPATION \_\_\_\_\_

AREA CODE \_\_\_\_\_ PHONE NUMBER \_\_\_\_\_

**AS YOUR PRIMARY RESIDENCE, DO YOU:**

OWN                       RENT

**DID YOU PURCHASE AN ADDITIONAL WARRANTY:**

EXTENDED       NONE

**REASON FOR CHOOSING THIS AVANTI PRODUCT:**

PLEASE INDICATE THE MOST IMPORTANT FACTORS THAT INFLUENCED YOUR DECISION TO PURCHASE THIS PRODUCT.

- PRICE
- PRODUCT FEATURES
- AVANTI REPUTATION
- PRODUCT QUALITY
- SALESPERSON RECOMMENDATION
- FRIEND/RELATIVE RECOMMENDATION
- WARRANTY
- OTHER \_\_\_\_\_

**YOUR AGE:**

UNDER 18             18-25                       26-30  
 31-35                 36-50                       OVER 50

**MARITAL STATUS:**

MARRIED             SINGLE

**IS THIS PRODUCT USED IN THE:**

HOME                 BUSINESS

**HOW DID YOU LEARN ABOUT THIS PRODUCT:**

ADVERTISING  
 IN STORE DEMO                       PERSONAL DEMO  
 OTHER \_\_\_\_\_

COMMENTS \_\_\_\_\_

\_\_\_\_\_

\_\_\_\_\_

**PRINTED IN CHINA**