

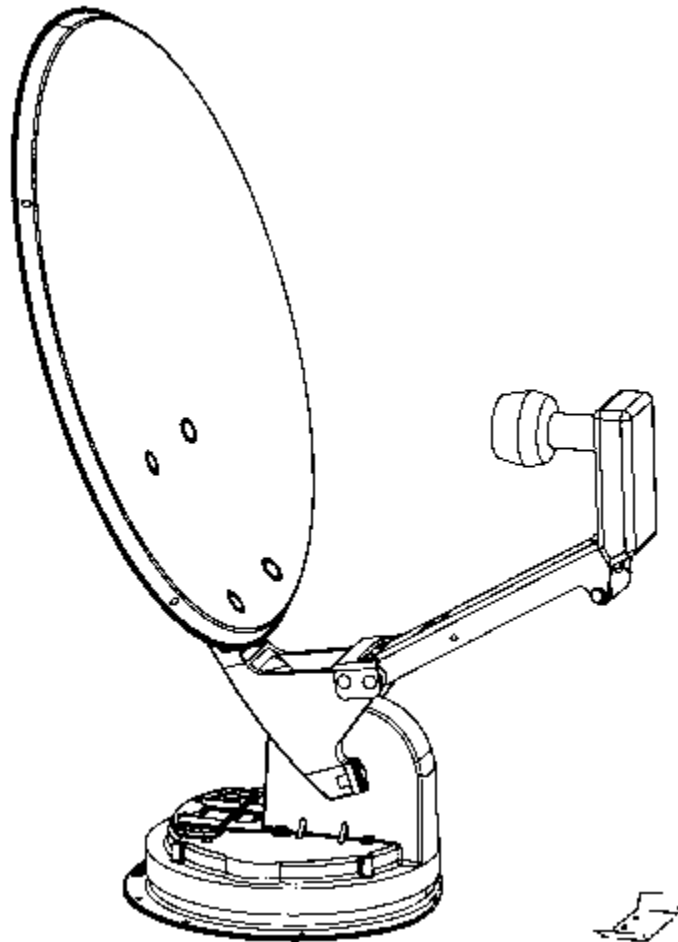

**RV DIGITAL SATELLITE ANTENNA
with Digital Elevation Sensor
Model RM-DM46**

may also be packaged as
RM-DM00, RMDM04, RMFLDM4



www.winegard.com
For Technical Services, call 1-800-788-4417
For Receivers and Programming, call 1-866-609-9374
DO NOT RETURN ANTENNA TO PLACE OF PURCHASE.

Operation

STEP 1. The more accurately you determine North, the easier it is to locate the satellite. Step outside and away from your vehicle. (Standing too near to your vehicle can give incorrect compass readings.) It is helpful if there is a landmark on the horizon to represent North. Return to the vehicle and point the directional dial North or to the landmark.

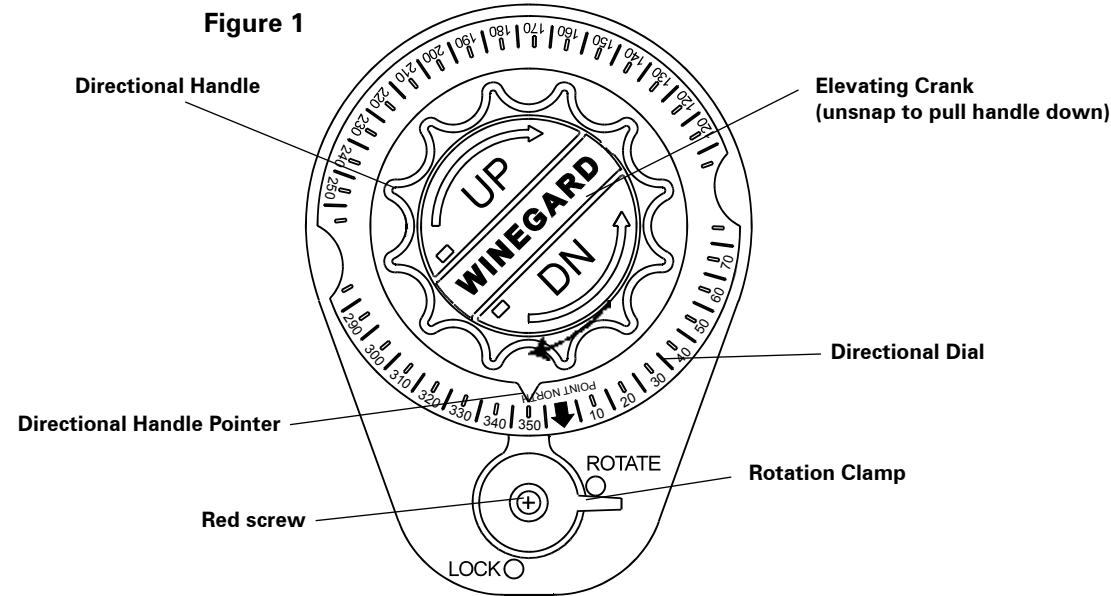

STEP 2. Turn on receiver and television. Tune the television to channel 3 or 4. Using your receiver manual for instructions, go to the Signal Meter screen. Enter nearest zip code for your location using receiver's remote control. After the zip code is entered, the receiver will indicate numbers for azimuth (compass heading) and elevation. Unsnap the elevating crank, and turn the elevation handle **CLOCKWISE** to raise the antenna. Turn the elevating crank **COUNTERCLOCKWISE** to lower the antenna.

STEP 3. Press the button on the Winegard digital display wall plate. If antenna is in travel position, the display will show LL for Low Limit. HL for High Limit will appear when the dish is in up position.

STEP 4. Crank the elevation handle to raise antenna. Stop cranking when the readout displays the correct elevation for your location, which is found on the receiver's signal meter screen.

STEP 5. Rotate antenna slowly until the correct satellite signal is acquired. NOTE: Rotate 3°, then stop. DO NOT rotate continuously, even if you are rotating slowly. If you notice the elevation angle has changed, it could be due to the following reasons:

1. RV is not parked level.
2. Antenna is mounted to a slightly sloped RV roof. (This is not a problem.)

When you have rotated the antenna so it is facing in approximately the right azimuth (compass direction), simply adjust to correct elevation, and continue searching for signal.

When you have detected the satellite signal, adjust the antenna up/down and left/right for the strongest signal the receiver displays. Due to variations in receivers and installation methods, you may find the elevation numbers (after peaking on the strongest signal) no longer match what the receiver recommended. This is normal. The elevation sensor should always get you close enough to pick up a signal to peak on. If the display turns off while you're searching, just push the button for another minute of operation. After a little practice, finding the signal may only take 30 to 50 seconds.

Replacement Parts

For replacement parts, contact Winegard Company at 1-800-288-8094 (credit card orders only, \$5.00 minimum order).

To order receivers or programming, please call the Winegard receiver hotline at 1-866-609-9374.

Tuning Antenna

STEP 1. Your receiver should indicate it is receiving a signal. To tune your antenna for the best signal strength, slowly move the antenna left, then right, until you have found the position that gives the highest signal strength. **It is important to turn the antenna slowly. Because the signal is digital, the receiver takes a few seconds to lock on.**

STEP 2. Place rotation clamp in the LOCK position. This prevents antenna movement and loss of signal.

STEP 3. Slowly raise then lower the antenna until you have peaked the signal. You are now ready to watch satellite TV!

Lowering Antenna to Travel Position

STEP 1. Set the rotation clamp to **ROTATE** position.

STEP 2. Rotate antenna until pointer on directional handle aligns with the red screw on the rotation clamp.

STEP 3. Turn elevating crank counterclockwise **in direction of DOWN arrow until meeting resistance.** The number of turns will vary according to the elevation angle the antenna was set at.

STEP 4. Move rotation clamp to the LOCK position. Antenna is now locked in travel position.

STEP 5. Snap elevation crank in place.



CAUTION! NEVER LOWER ANTENNA IN ANY POSITION EXCEPT TRAVEL POSITION!

DOs

1. **Do** check parking location for obstructions before raising antenna.
2. **Do** carefully raise, lower and rotate antenna. If difficult, check for cause.
3. **Do** rotate slowly when searching for the satellite(s), and check fine tuning on TV set to make sure it is properly adjusted.
4. **Do lower antenna before moving vehicle!**
5. **Do** activate programming by calling program provider for your receiver.

DON'Ts

1. **Don't** move RV/coach with the antenna in the UP position. This will void your warranty and may also cause damage to your roof.
2. **Don't** force elevating crank up or down. Check for cause of trouble.
3. **Don't** rotate directional handle hard against stops.
4. **Don't** apply paint over top of base plate or anywhere on lift.
5. **Don't** apply sealant on gear housing.

Troubleshooting

Figure 2
Antenna Reflector at 90°

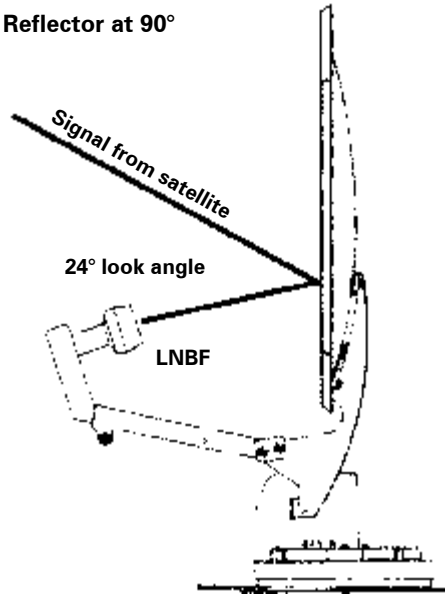

1. You may need to rotate the dish in small increments to find the signal. Rotate the dish 3° at a time to the left, stopping for a few seconds each time you move the dish. Try moving the dish up to 20° to the left. If no signal is found, return to the azimuth listed and try rotating 20° to the right. This will help correct for any errors in setting the directional handle.

2. Be sure you have a clear line of sight. The signal from the satellite(s) **will not** pass through trees, buildings, mountains, etc. Remember the antenna has a 24° offset; this means that when the antenna is straight up and down (90°), it is looking 24° into the sky. See Figure 2.

3. Check that the TV set is tuned for the correct channel, 3 or 4 (same channel as output of receiver).

4. Check that you have entered the correct zip code of your current location. If the zip code is wrong, the antenna will be looking in the wrong direction or at the wrong elevation for the satellite signal.

5. Check connections at the receiver, TV, and antenna.

6. Check the TV. Does it receive pictures from off-air television stations/VCR?

7. Re-tune system for best picture. See page 3.

8. Inspect the antenna, making sure it has not been damaged. If the antenna is even slightly bent, the receiver may not receive the signal.

9. Contact Dealer or Winegard Technical Services.

If Antenna Does Not Rotate or Is Difficult to Rotate

1. Inspect antenna on roof. Be sure the mount has not been damaged.
2. Check for caulking between gear housing and base plate.
3. Be sure cables are not binding and that they have been installed properly.
4. Contact your dealer or Winegard Technical Services.

If Antenna Does Not Raise or Is Difficult to Raise

1. Inspect antenna on roof. Be sure the mount has not been damaged.
2. Check for caulking on the elevating shaft.
3. Contact your dealer or Winegard Technical Services.

LCD DISPLAY CODES

HL	High Limit
LL	Low Limit
Lo	Battery Low
Er	Error
--	Initializing

NOTE: Initialization may take up to 5 seconds.

Assembly & Installation

Supplies Needed

Screwdrivers (Phillips and slot)
1-3/4" hole saw
7/16" wrench

ABS glue
Drill with 1/8" bit
Tape measure

Non-hardening sealant
(Check manufacturer's specifications for compatibility with your roof.)

Winegard's Digital Elevation Sensor has been INSTALLED and CALIBRATED at the factory.

STEP 1. Choose a location on the roof for the dish that will allow the dish to raise and rotate without interfering with other roof-mounted equipment. Make sure inside ceiling plate is easily accessible and with no obstructions that would interfere with operation.

Figure 3 shows minimum distance (10") antenna should be located from edge of vehicle roof. It is recommended that you check with your dealer or manufacturer for provisions that may have been made in the roof for antenna mounting, such as a reinforced roof area or pre-wire installation from the factory.

Figure 3

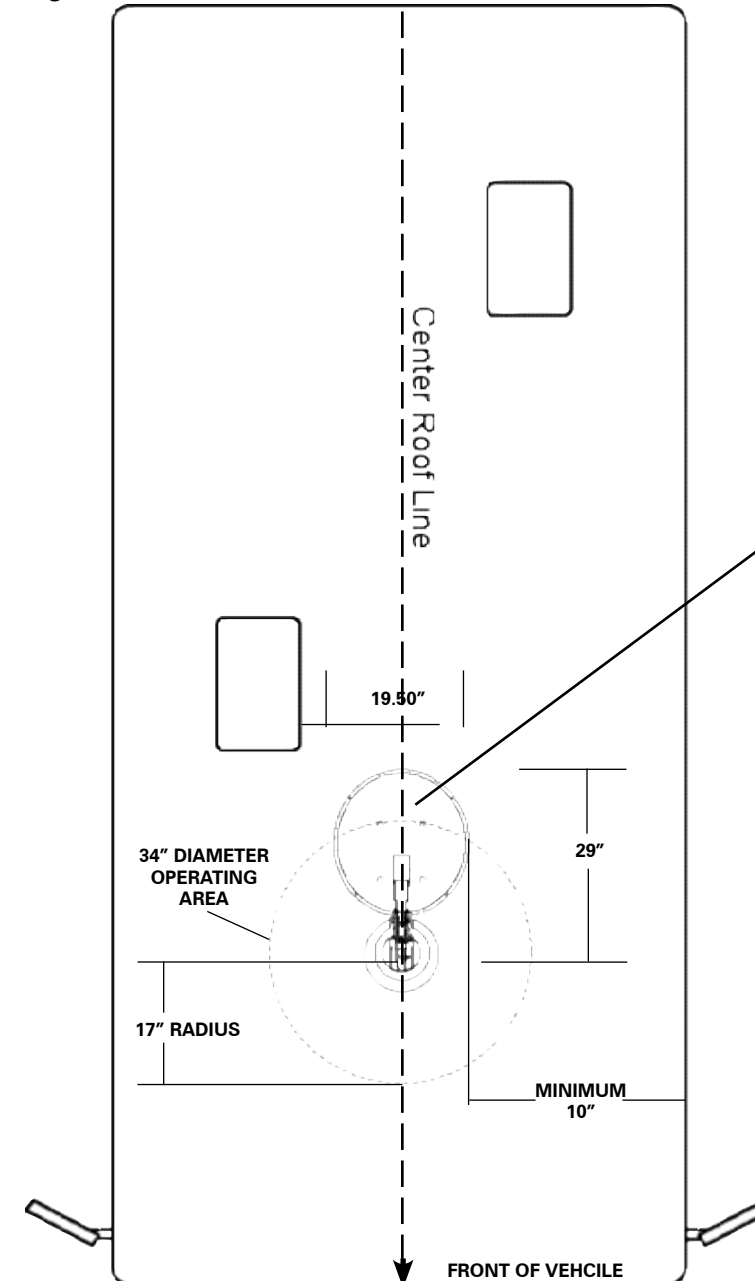

The antenna must be level for proper operation!

Winegard Model RW-5000 roof wedge with gasket is available. If inside roof wedge is needed, Winegard Model RW-1000 can be trimmed to fit ceiling plate.

STEP 2. Position template on roof (see insert page of this manual). **CAUTION: DO NOT drill through wiring.** Carefully drill a 1-3/4" hole through roof and ceiling of vehicle. Inspect hole to make sure wiring is intact. See roof template insert.

It is highly recommended the antenna be mounted on the center line of the roof. Do not mount antenna closer than 10" from roof edge.

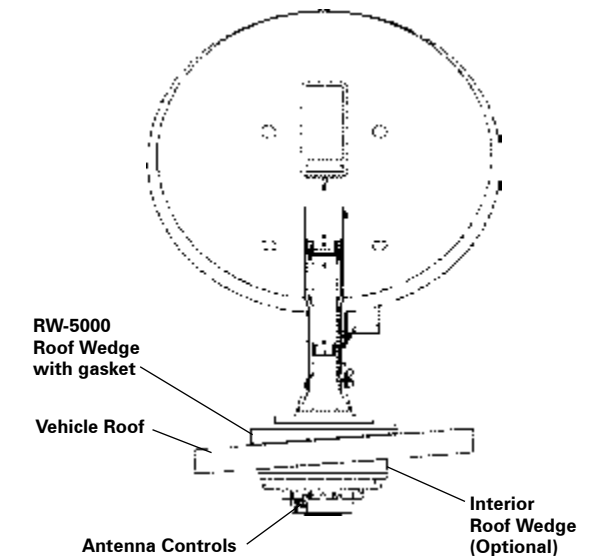

STEP 3. Attach dish to backup. Use bolts and nuts provided. See Figure 4.

STEP 4. Mount dish on roof in upright position. Rotate clockwise to stop (Figure 5). Dish will be toward back of vehicle when in stowed or travel position. The word FRONT is embossed on the base and should face the front of vehicle. Secure to roof using screws (provided). The travel bracket should be mounted to roof 6-1/8" from base of dish, toward back of vehicle. See Figure 6.

NOTE: Apply non-hardening sealing compound to screw heads, coax access hole and edge of gasket under mount base.

Install the vent tube on the back of the mount base (the side opposite the word FRONT). The hole for the vent tube is shown in Figure 6A. **CAUTION: DO NOT seal hole in vent tube.** Put sealant around the outside of the vent tube, approximately 1/2" from end. Push vent tube into the hole. The sealant will seal the hole as you push in vent tube. Leave approximately 2 to 2-1/2" of the vent tube extending from the hole. Put a small amount of sealant on the roof under the vent tube end to hold in place.

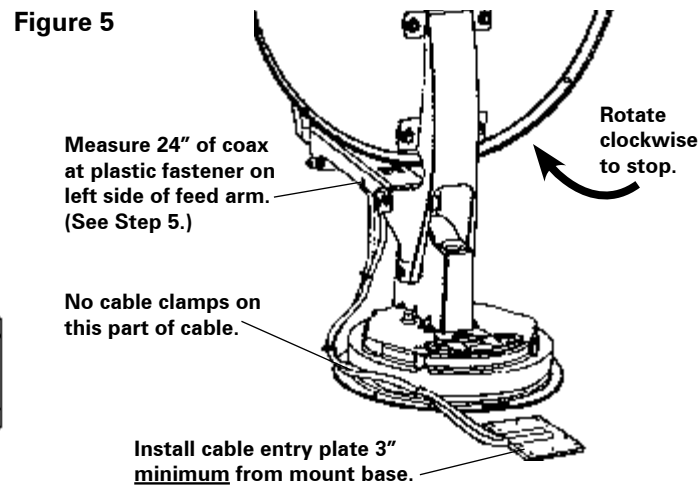
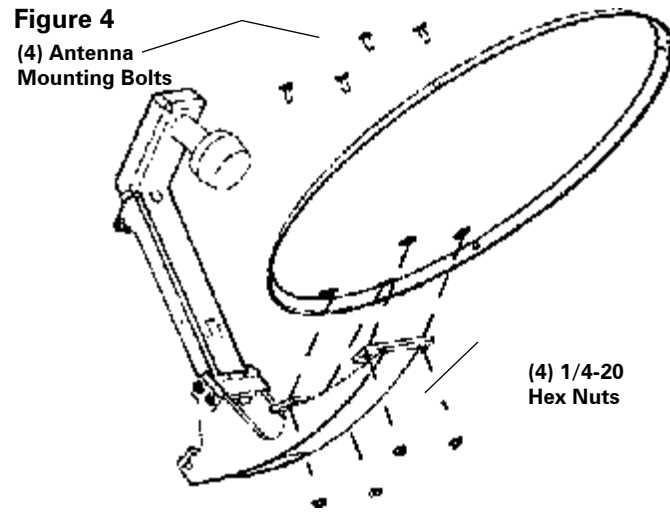

Another Method of Installing Roof/Cable Entry Plate
Attach cable to roof using cable clamps. Use sealant to seal screw heads.

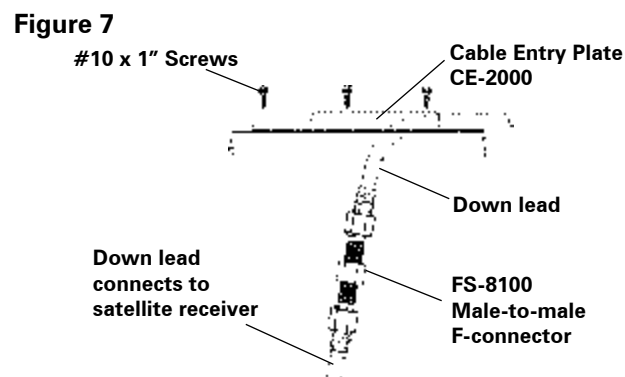

Digital Elevation Sensor Roof Connections

The illustrations below show the different methods of connecting wires at roof level; method will depend on model. Wire colors must match, i.e. red to red, green to green, black to black.

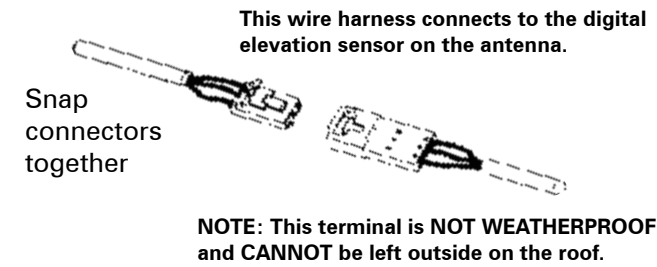

Supplied with DM-2000 only

3M UR TERMINAL
DO NOT STRIP wires. Terminal is self-stripping. Squeeze pliers until red plunger is flush with rest of terminal. (Pliers not supplied.)

NOTE: This terminal is weatherproof and can be left outside on the roof IF SECURED PROPERLY to prevent wind whipping.

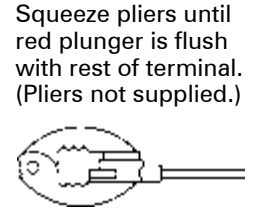

Inside RV

For roof thickness greater than 6-1/2".

Parts Needed: (not included)
14" worm gear for roof
Directional handle extension
Long threaded rod

Instructions:

STEP 8. Place nut on threaded rod. See Figure 8.

STEP 9. Measure and cut the threaded rod with a hacksaw. Use the chart (Figure 10) to determine the correct length.

STEP 10. Remove the nut over the cut end of the threaded rod. This cleans the threads after cutting.

STEP 11. Thread the cut end of the rod into the hub.

STEP 12. Install the ceiling plate. The rotate/lock lever must point toward the rear of the vehicle.

Be sure rotate/lock lever is pointing towards the rear of the vehicle and that the hole in ceiling plate aligns with hole in the ceiling.

Refer to the chart to determine the correct length for the directional handle. Extensions may be needed. Each extension adds 2-1/4" to directional handle. **DO NOT cut the extension.** If the directional handle must be extended by less than 2-1/4", cut the directional handle to fit.

A tube cutter is recommended for cutting the directional handle. This gives a square cut; a hacksaw does not.

Be sure large and small keyways line up in the hub and directional handle!

Figure 9
DIRECTIONAL HANDLE

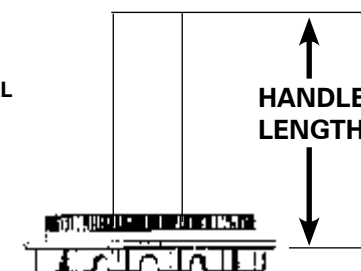
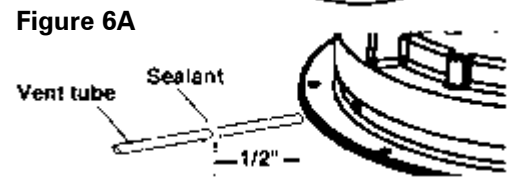
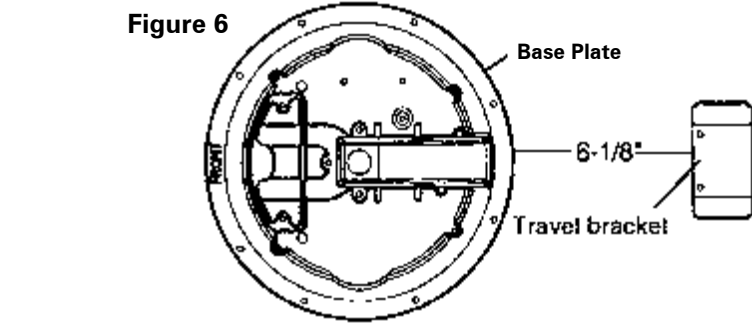

Figure 10

Roof Thickness	Directional Handle Length (Figure 9)	Threaded Rod Length	Worm Gear Shaft Length (Figure 11)
1-1/2"	2-7/8"	2-3/4"	2-7/8"
1-3/4"	3-1/4"	3"	3-1/8"
2"	3-1/2"	3-1/4"	3-1/2"
2-1/4"	3-7/8"	3-1/2"	3-7/8"
2-1/2"	4-1/8"	3-3/4"	4-1/8"
2-3/4"	4-1/2"	4"	4-1/2"
3"	4-3/4"	4-1/4"	4-3/4"
3-1/4"	5"	4-5/8"	4-7/8"
3-1/2"	5-1/4"	4-7/8"	5-1/8"
3-3/4"	5-5/8"	5-1/4"	5-1/2"
4"	5-3/4"	5-1/2"	5-3/4"
4-1/4"	6-1/8"	5-3/4"	6-1/8"
4-1/2"	6-1/2"	6"	6-1/4"
4-3/4"	6-5/8"	6-1/8"	6-3/8"
5"	6-7/8"	6-3/8"	6-5/8"
5-1/4"	7-1/8"	6-5/8"	7"
5-1/2"	7-3/8"	6-7/8"	7-1/4"
5-3/4"	7-5/8"	7-1/4"	7-1/2"
6"	7-7/8"	7-1/2"	7-3/4"
6-1/4"	8-1/8"	7"	8"
6-1/2"	8-1/2"	7-3/4"	8-1/4"
6-3/4"	8-3/4"	8"	8-1/2"
7"	9"	8-1/4"	8-7/8"
7-1/4"	9-3/8"	8-5/8"	9-1/8"
7-1/2"	9-5/8"	8-7/8"	9-3/8"
7-3/4"	9-7/8"	9-1/8"	9-5/8"
8"	10-1/8"	9-3/8"	10"
8-1/4"	10-3/8"	9-5/8"	10-1/4"
8-1/2"	10-3/4"	9-7/8"	10-3/8"
8-3/4"	11"	10"	10-5/8"
9"	11-1/4"	10-1/4"	11"
9-1/4"	11-1/2"	10-5/8"	11-1/4"
9-1/2"	11-3/4"	10-7/8"	11-1/2"
9-3/4"	12"	11-1/8"	11-3/4"
10"	12-3/8"	11-3/8"	12"
10-1/4"	12-5/8"	11-5/8"	12-1/4"
10-1/2"	12-7/8"	11-7/8"	12-1/2"



CAUTION: DO NOT GET sealing compound between base plate and rotating gear housing. DO NOT PAINT top of base plate or around rotating gear housing.

STEP 5. Facing the front of the dish, note the coax attached to the side of the feed arm. Measure 24" coax from this point. **DO NOT CUT.** Put coax around mount base, Figure 5.

STEP 6. Apply approved sealing compound over mounting screw heads in base plate.

STEP 7. Feed coax through the roof using cable entry plate (included). See Figure 7. **Weatherproof the cable entry** by applying sealant under lip of cable entry plate and where cable enters roof. Attach plate to roof with screws provided. Apply sealant over screws and around edge of roof-thru plate, making sure cable entry is sealed. **If downlead connection is made on top of roof, make sure to weatherproof connection!**

STEP 15. The directional handle and threaded rod will fit roofs up to 5¼" thick. If you are using wedges to compensate for roof/ceiling slope, be sure to allow for this extra thickness. You may add an extension to the directional handle for thicker roofs. Each extension will increase the length of the directional handle by 2¼". See Figure 11.

Figure 11

WITH ROOF WEDGE
Measure from top of roof wedge to ceiling.

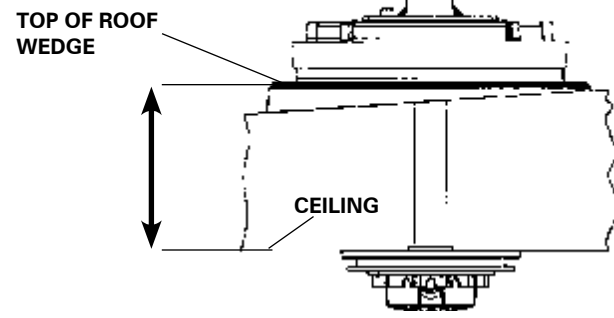

WITHOUT ROOF WEDGE
Measure from top of roof to ceiling.

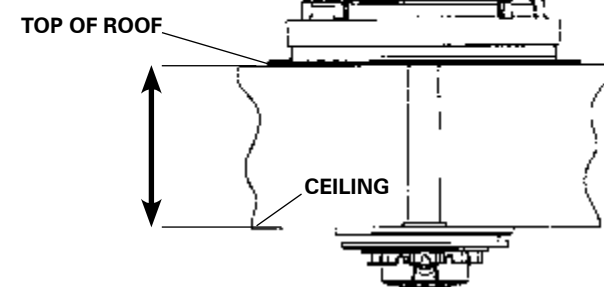

STEP 16. Press the directional handle onto the hub. Point arrow on the directional handle towards the rotate/lock lever to orient to the splines.

STEP 17. Install the washer and nut on the threaded rod. Tighten the nut enough to snug the directional handle to the hub.

STEP 18. IF YOU ARE USING AN EXTENSION, adjust the total length of the directional handle and extension by **cutting the directional handle.** After adjusting parts for proper roof thickness, glue the extension to the directional handle. Use ABS (plastic pipe) glue.

NOTE: For roofs over 5¼" thick, a longer aluminum hex shaft is needed. Contact Winegard for this part.

Figure 12

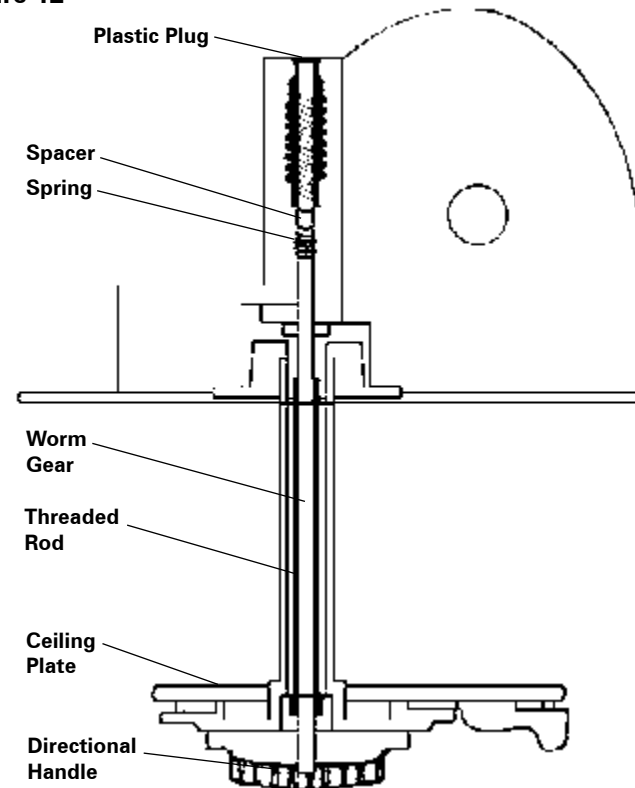

Cutting Shaft Length

Flip down handle on the elevating crank handle. Slide elevating crank handle up shaft until snug against the directional handle. Mark the elevating shaft at the inside bottom surface of crank handle housing (Figure 13). After removing crank handle, cut shaft at mark. Re-install crank.

Figure 13

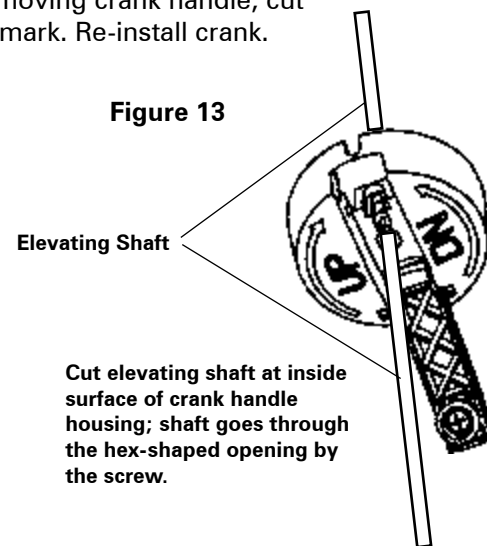

CAUTION!
After initial installation, the antenna **SHOULD ROTATE APPROXIMATELY 360° FROM TRAVEL POSITION.**

The pointer on the directional handle should point towards the **RED SCREW ON THE ROTATION CLAMP** when in the **TRAVEL POSITION.**

Figure 14

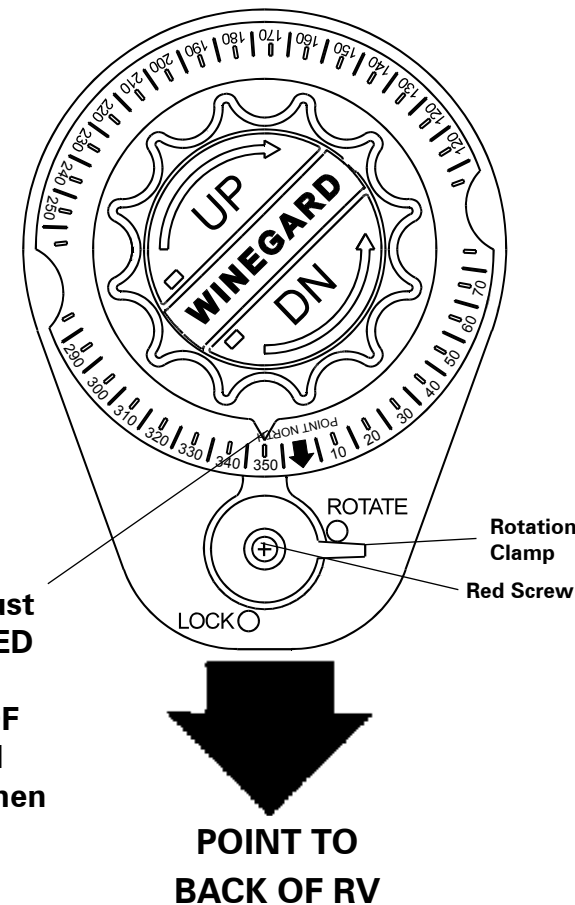

Pointer must point to **RED SCREW** at **CENTER OF ROTATION CLAMP** when in travel position.

CAUTION!
The antenna must be in the travel position before aligning the directional handle and ceiling plate!

Figure 15

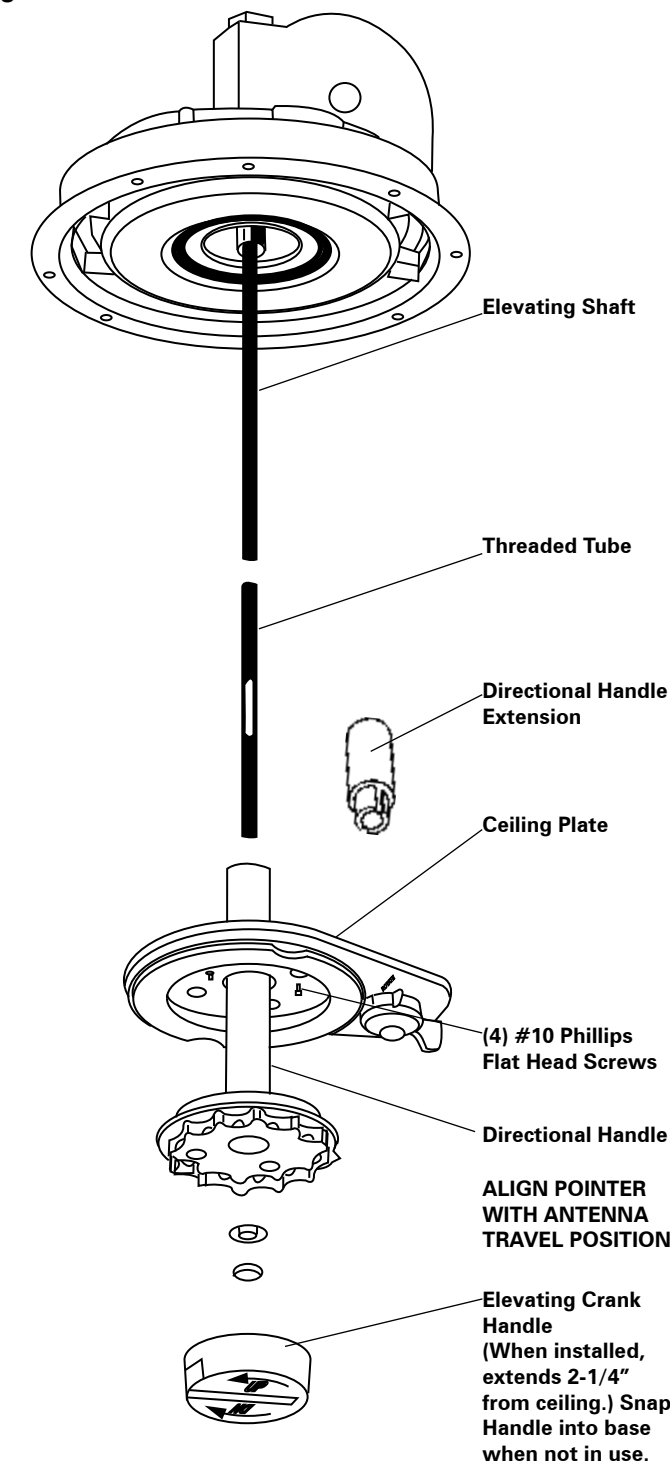
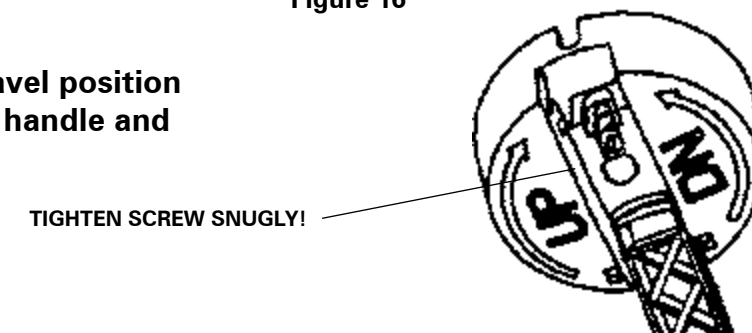

Figure 16



Digital Elevation Sensor Interior Wall plate

Figure 17

STEP 19. See Figure 17. If using the SM-1000 surface mount box, feed cable through hole in box.

STEP 20. Connect wires coming from sensor on roof to wall plate display in vehicle. It is important to properly connect the wires at the roof and the wall plate. (Plug will click when inserted properly.) The system is designed to use a 9 volt battery OR +12 VDC from vehicle. Do not use both! **IMPROPER WIRING WILL CAUSE DAMAGE TO THE PRODUCT.** See Figure 18.

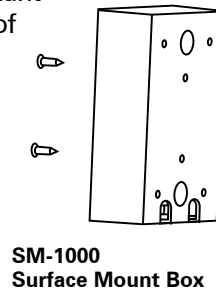

STEP 21. Pressing the button when the antenna is in a vertical position should display 24 ($\pm 1^\circ$). The display will automatically turn off after 1 minute.

STEP 22. Check connectors and cable entry points. Be sure these areas are properly sealed to prevent water damage.

Figure 18

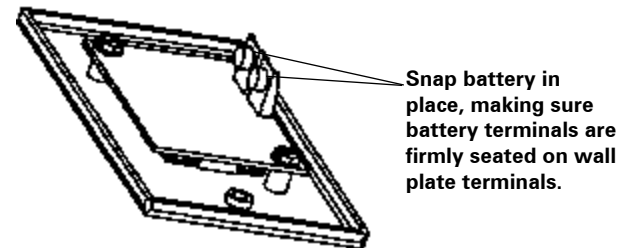

Based on 5 minutes a day of usage, standard new alkaline batteries should last 88 days.

OPERATION (Also on pages 2-3)

STEP 23. Using satellite receiver, find correct elevation for your location. See the receiver manual for details of setup information.

STEP 24. Press button on Winegard digital display wall plate. If antenna is in travel position, the display will show LL for Low Limit.

STEP 25. Crank elevation handle to raise antenna. Stop when readout displays correct elevation for your location. (Found on receiver setup menu.)

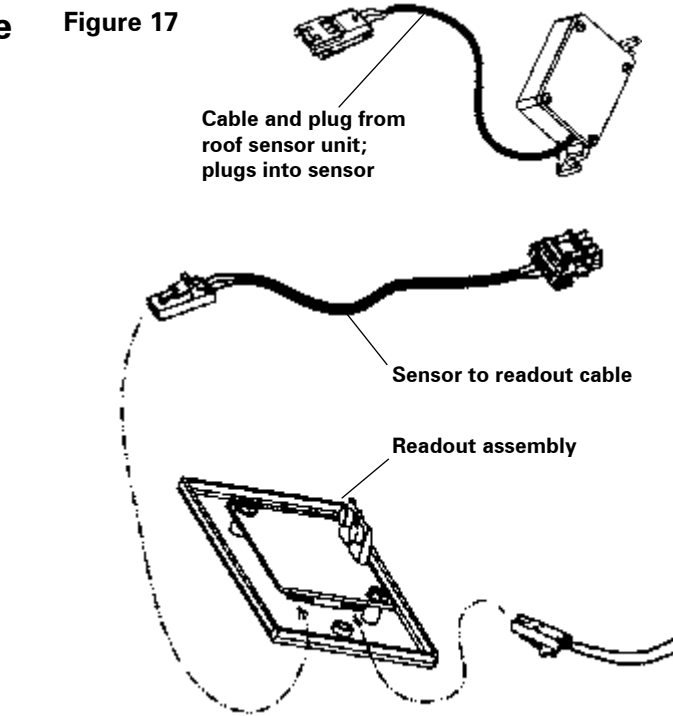

STEP 26. Rotate antenna VERY SLOWLY until correct satellite signal is acquired. Rotate 3° , and stop. DO NOT rotate continuously even if you're rotating slowly. If the elevation angle has changed, it could be due to the following:

- Vehicle is not parked level.
- Antenna system mounted on slightly sloped roof. If this is the reason, after you have rotated the antenna to the approximately correct compass direction, adjust to correct elevation and continue search.

Note: When you have found the satellite signal, adjust the antenna up/down and right/left for the strongest signal your receiver displays. Due to variation in receivers and installation methods, you may find the elevation numbers after peaking on strongest signal no longer match what the receiver display recommended. This is normal. The elevation sensor should always get you close enough to pick up a signal to peak on. If display turns off while you're searching, just push the button for another minute of operation. With a little practice, most users find the signal in 30 to 50 seconds.

Parts List

BACK VIEW

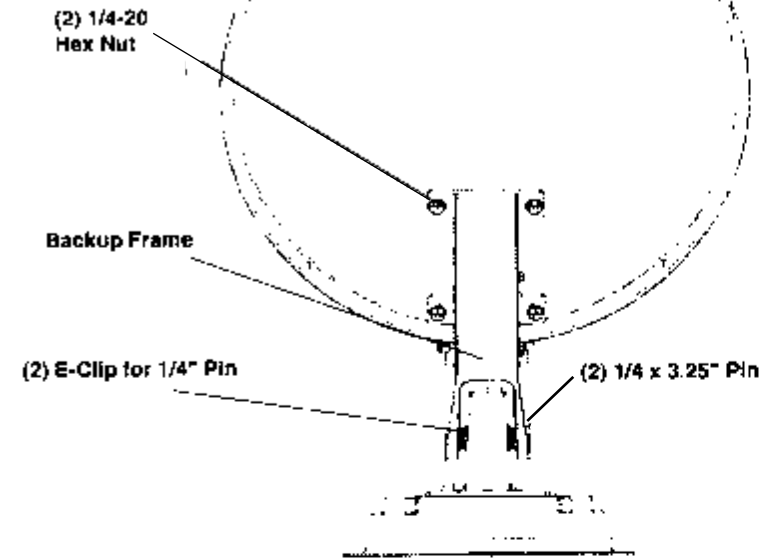

Cutaway view of mount/gear housing

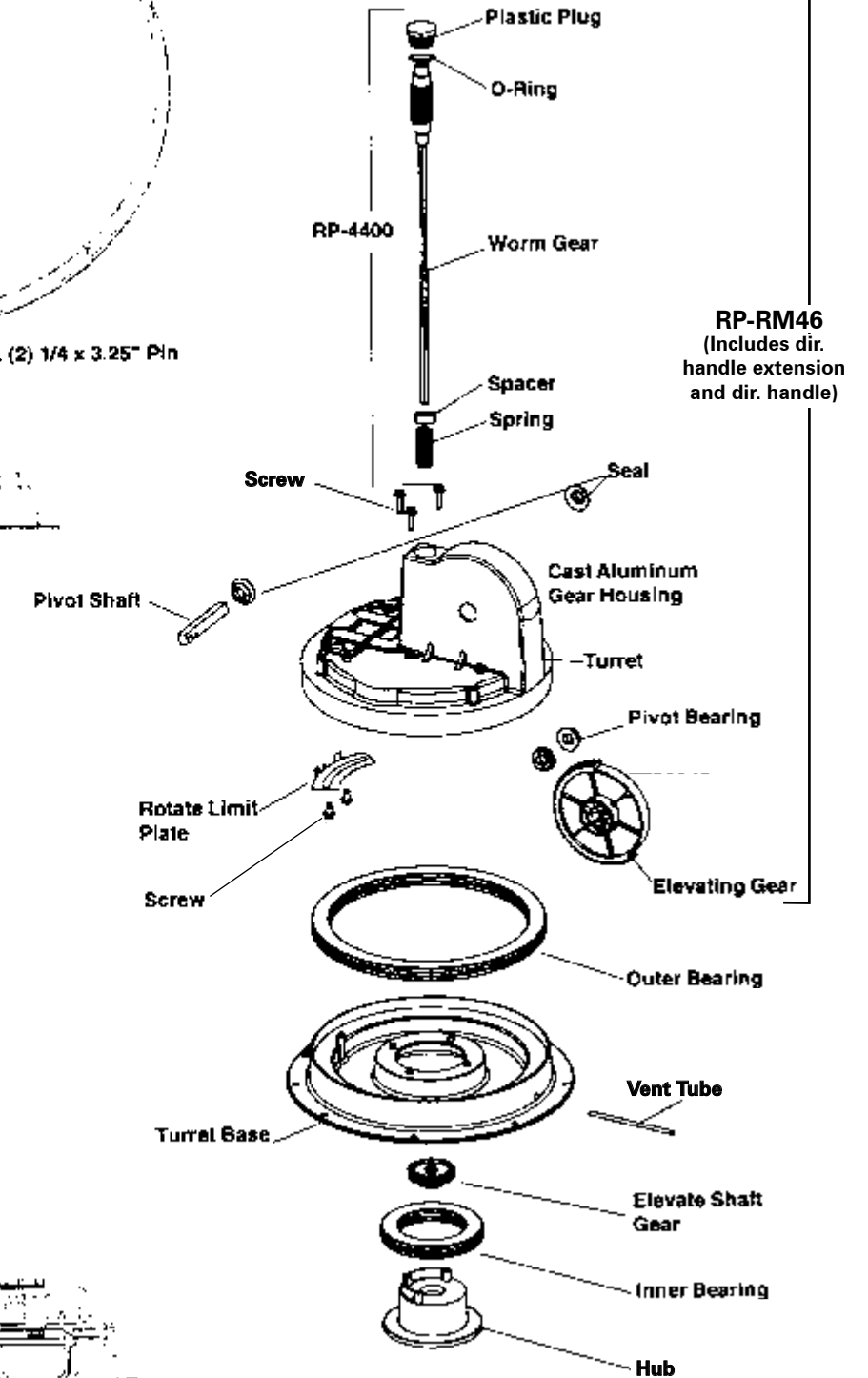
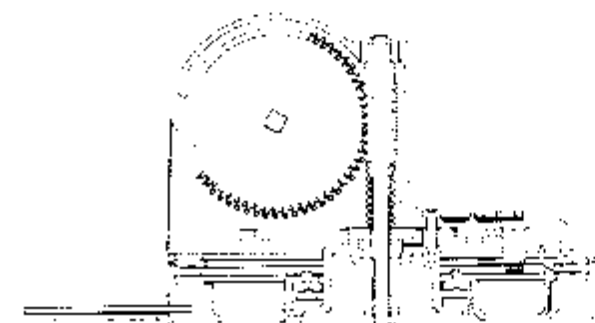

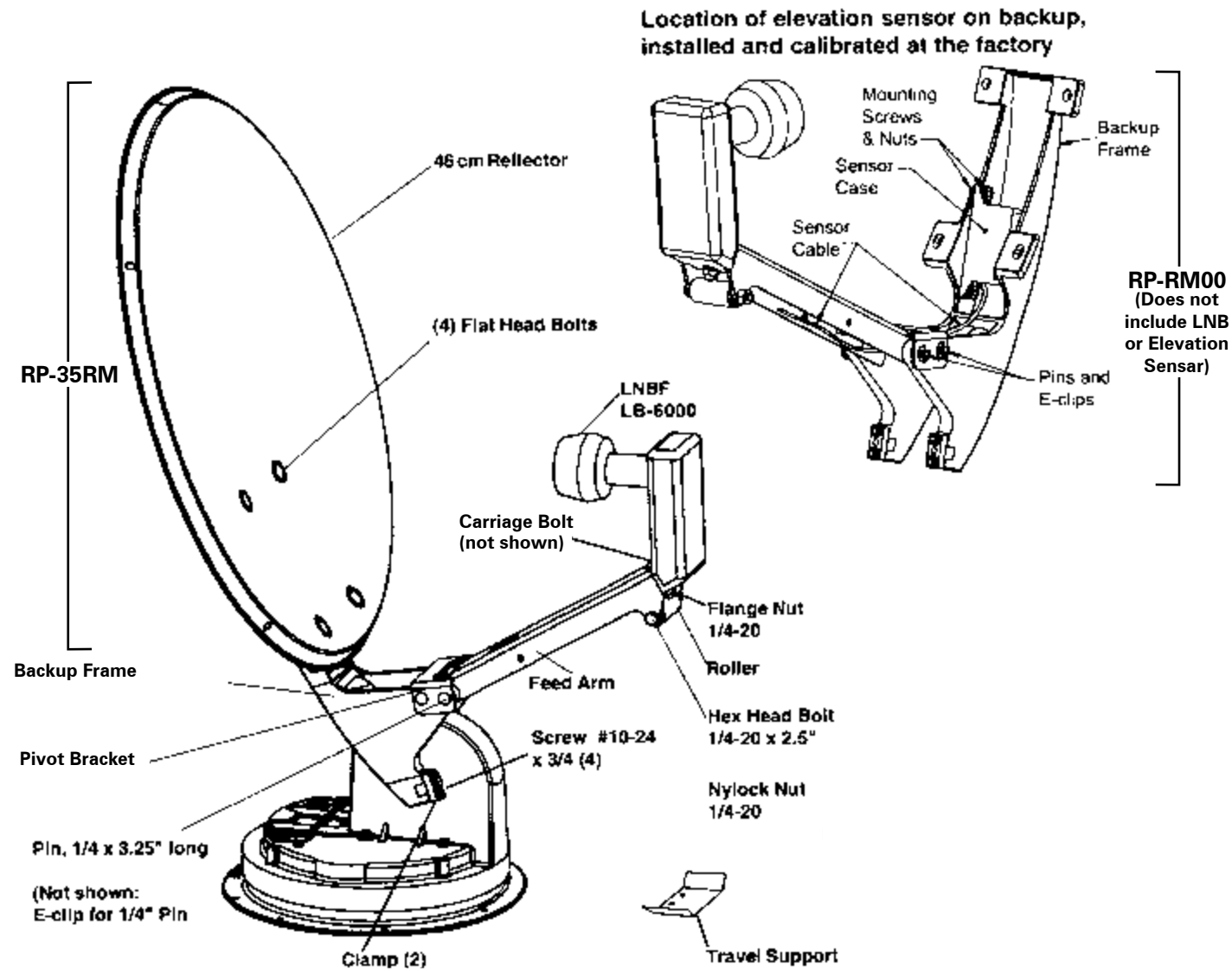

Sensor parts w/cable, installed at factory

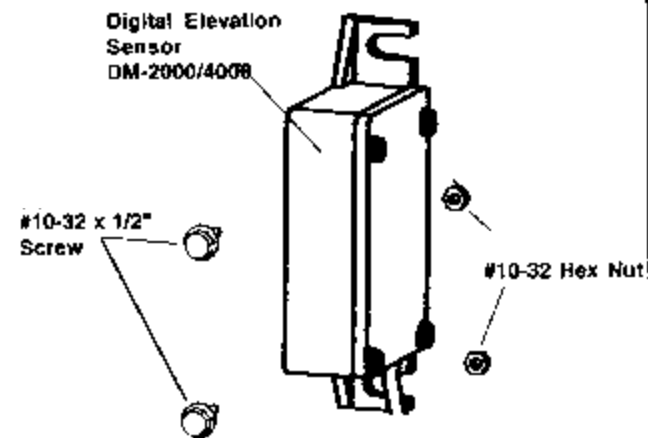

Interior wallplate display and parts

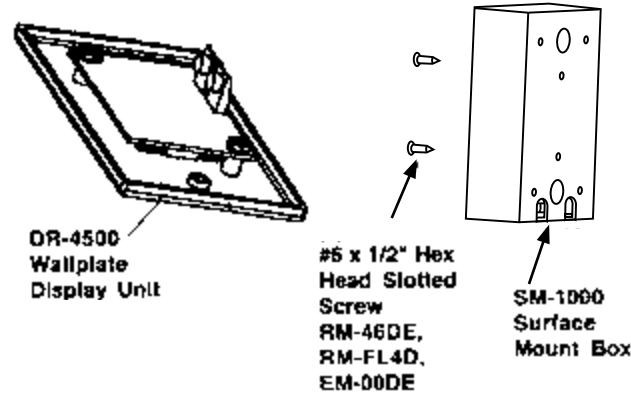

INTERIOR HARDWARE KIT RK-CEIL

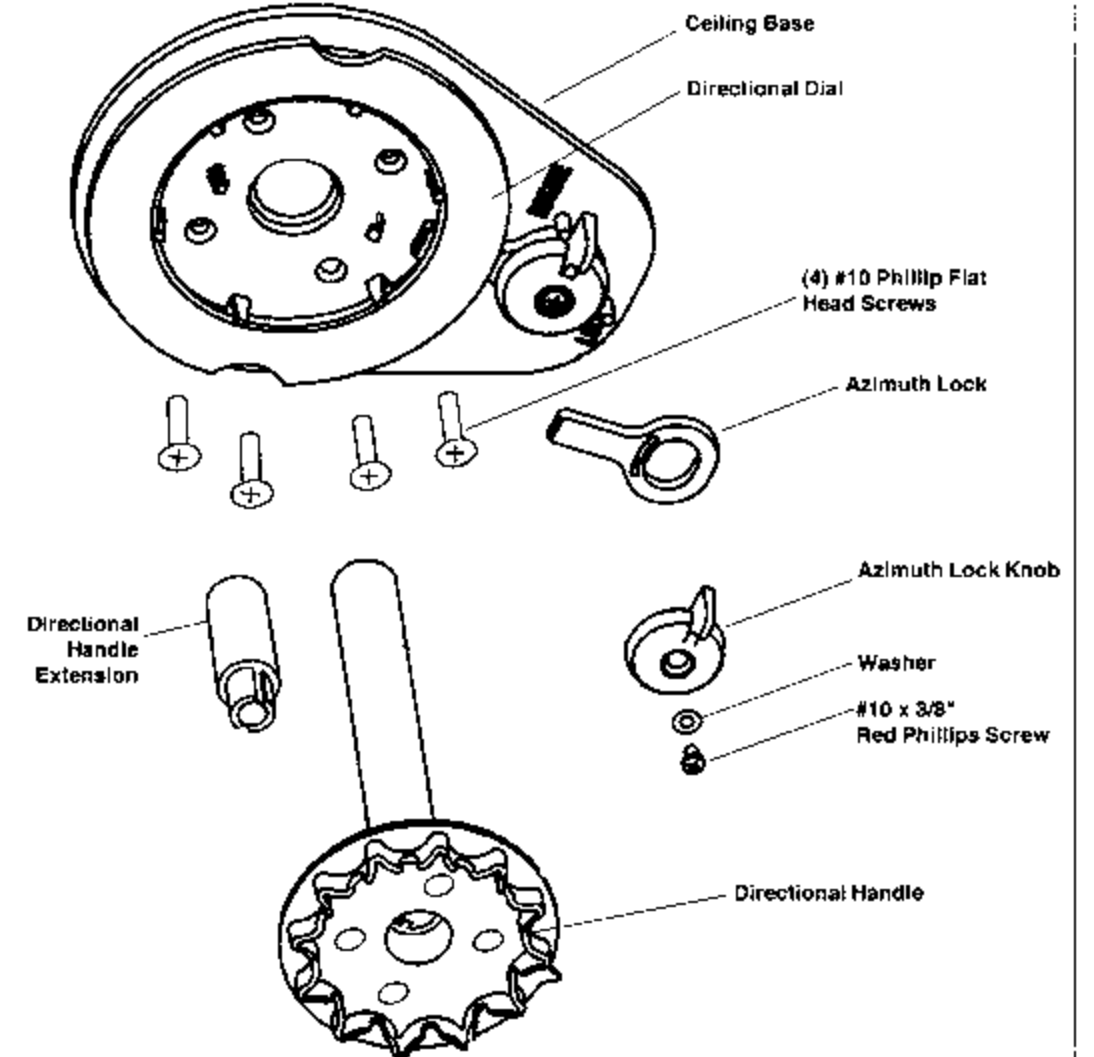

CRANK HANDLE KIT RK-HAND

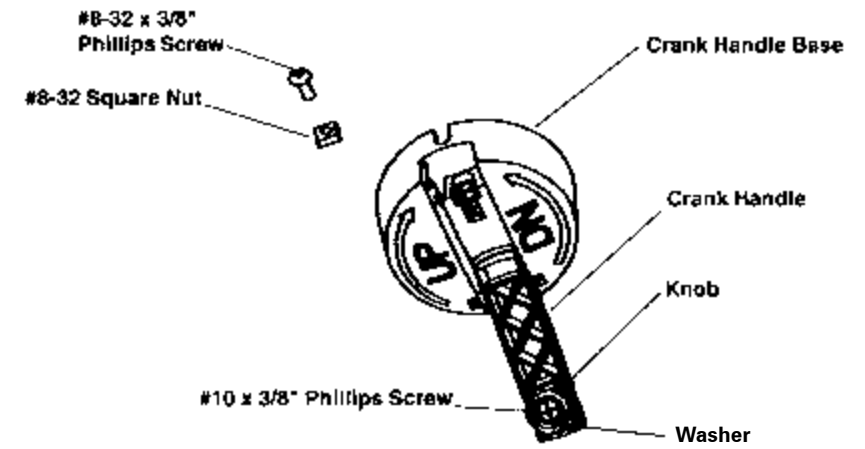

NOT TO SCALE

Specifications

Antenna & Mount

Height when raised: 30" vertical max.
Height in the travel position: 8" max.
Operating radius: 17"
Roof space required: 26"
Compatible with DIRECTV®, DISH Network®, and Bell TV™

Weight: 12 lbs
Color: cool gray
Antenna height: 20.9"
Antenna width: 19.2"
F/D: 0.59
Offset angle: 24°
Frequency range: 10.95–12.75 GHz

Gain:
11.2 GHz, 33.22 dBi
12.1 GHz, 33.89 dBi
12.6 GHz, 34.23 dBi
Aperture efficiency: 73%
Beamwidth at -3 dB: 3.5°
Beamwidth at -10 dB: 7.0°
Wind loading: up to hurricane force

WINEGARD MOBILE PRODUCTS LIMITED WARRANTY (2 YEARS PARTS; 1 YEAR LABOR)

Winegard Company warrants this product against defects in materials or workmanship for a period of two (2) years from the date of original purchase. During year one (1) of such warranty, Winegard Company will also pay authorized labor costs to an authorized Winegard dealer to repair or replace defective products. No warranty claim will be honored unless at the time the claim is made, Customer presents proof of purchase to an authorized Winegard dealer (to locate the nearest authorized Winegard dealer, contact Winegard Company, 3000 Kirkwood Street, Burlington, Iowa 52601, Telephone 800-288-8094 or visit www.winegard.com). Customer must provide proof of purchase with a dated sales receipt for the Winegard product to verify the product is under warranty. If the date of purchase cannot be verified, the warranty period shall be considered to begin thirty (30) days after the date of manufacture.

If a defect in material or workmanship is discovered, Customer may take the product to an authorized Winegard dealer for service. Customer must provide proof of purchase to verify the product is under warranty. If the product is brought to an authorized Winegard dealer for service prior to expiration of year one (1) of the warranty period and a defect in material or workmanship is verified by Winegard Technical Services, Winegard Company will cover the Winegard dealer's labor charges for warranty service. The Winegard dealer must contact Winegard Technical Services in advance for pre-approval of the service. Approval of the service is at the sole discretion of Winegard Company.

Alternatively, Customer may ship the product prepaid to Winegard Technical Services (located at 3111 Kirkwood Street, Burlington, Iowa 52601, Telephone 800-788-4417). Customer must return the product along with a brief description of the problem and provide Winegard Technical Services with Customer's name, address, and phone number. Customer must also provide proof of purchase to verify the product is under warranty. If the product is returned before the expiration of the warranty period, Winegard Company will (at its option) either repair or replace the product.

This Limited Warranty does not apply if the product has been damaged, deteriorates, malfunctions or fails from: improper installation, misuse, abuse, neglect, accident, tampering, modification of the product as originally manufactured by Winegard in any manner whatsoever, removing or defacing any serial number, usage not in accordance with product instructions or acts of nature such as damage caused by wind, lightning, ice or corrosive environments such as salt spray and acid rain. This Limited Warranty also does not apply if the product becomes unable to perform its' intended function in any way as a result of the television signal provider making any changes in technology or service.

RETURN AUTHORIZATION POLICY

A Return Material Authorization (RMA) is required prior to returning any product to Winegard Company or Winegard Warranty Services under this warranty policy. Please call our Technical Services Department at 800-788-4417 or send an e-mail to warranty@winegard.com to obtain the RMA number. Please furnish the date of purchase when requesting an RMA number. Enclose the product in a prepaid package and write the RMA number in large, clear letters on the outside of the package. To avoid confusion or misunderstanding, a shipment(s) without an RMA number(s) or an unauthorized return(s) will be refused and returned to Customer freight collect.

WINEGARD COMPANY DOES NOT ASSUME ANY LIABILITIES FOR ANY OTHER WARRANTIES, EXPRESS OR IMPLIED, MADE BY ANY OTHER PERSON.

ALL OTHER WARRANTIES WHETHER EXPRESS, IMPLIED OR STATUTORY INCLUDING WARRANTIES OF FITNESS FOR A PARTICULAR PURPOSE AND MERCHANTABILITY ARE LIMITED TO THE TWO YEAR PERIOD OF THIS WARRANTY.

In states that do not allow limitations on implied warranties, or the exclusion of limitation of incidental or consequential damages, the above limitations or exclusions do not apply.

Some states do not allow limitations on how long an implied warranty lasts, or the exclusion of limitation of incidental or consequential damages, so the above limitations or exclusions may not apply to you.

This warranty gives Customer specific legal rights. Customer may also have other rights that may vary from state to state.

SATELLITE RECEIVER WARRANTY

See manufacturer's limited warranty policy

WS-MOBWARREV2 Rev. 1/10

Disclaimer: Although every effort has been made to ensure that the information in this manual is correct and complete, no company shall be held liable for any errors or omissions in this manual. Changes and technological advances are continuously being made in the satellite market. Information provided in this manual was accurate at time of printing. If the antenna does not function as expected, please contact Winegard Company at 1-800-788-4417, or visit our website at www.winegard.com.

Winegard Company • 3000 Kirkwood Street • Burlington, IA 52601 • 800-288-8094 • Fax 319-754-0787
www.winegard.com • Printed in U.S.A. ©2002 Winegard Company Rev7 11/11 2451069

Winegard is a registered trademarks of Winegard Company. DISH Network is a registered trademark of the EchoStar Satellite, L.L.C. DIRECTV is a registered trademark of DIRECTV, Inc., a unit of Hughes Electronics Corp. Bell TV is a trademark of Bell Canada, Inc. All trademarks are property of their respective owners.