

*Belshaw*

# Convection Ovens

Model BXC Smartbake  
4-Tray & 10-Tray

Belshaw Bros., Inc.

1750 22<sup>nd</sup> Ave. S.

Seattle, WA 98144

Phone: 206-322-5474 • Fax: 206-322-5425

Toll Free: 1-800-578-2547

E-mail: [service@belshaw.com](mailto:service@belshaw.com)

<http://www.belshaw.com>



If you accept the machine from the shipping company, you are, in effect, saying that the machine is in good condition, and you must pay for the machine. Belshaw cannot pay for shipping damage, because the freight company has accepted the machine from Belshaw in good condition, and is responsible for its safe delivery. For your protection, inspect the machine to see that no parts are bent, scratched, or otherwise damaged. If any damage has occurred in shipping, file a freight claim with the shipping company immediately.

## WARNING

**Keep this manual available at all times for use.**

## EQUIPMENT RECORD

Please provide the information below when you correspond with us about your machine.

Purchased by \_\_\_\_\_

Installed by \_\_\_\_\_

Date of Installation \_\_\_\_\_

Model number \_\_\_\_\_

Serial number \_\_\_\_\_

1004

MN-1881EN

Belshaw Bros., Inc.

1750 22<sup>nd</sup> Ave. S.

Seattle, WA 98144

Phone: 206-322-5474 • Fax: 206-322-5425

Toll Free: 1-800-578-2547

E-mail: [service@belshaw.com](mailto:service@belshaw.com) • <http://www.belshaw.com>



---

# Contents

## **Sections**

<b>1</b>	<b>Installation</b>	<b>1</b>
	Unpacking the oven	1
	Dimensions and Specifications	1
	Installation	2
	Initial Cleaning	2
	Programming the control panel	3
<b>2</b>	<b>Operation</b>	<b>5</b>
	Operating conditions	5
	Operating using programmed settings	5
<b>3</b>	<b>Cleaning and Maintenance</b>	<b>7</b>
	Daily cleaning	7
	Weekly cleaning	7
	Maintenance	8
	Lubrication	8
<b>4</b>	<b>Troubleshooting</b>	<b>10</b>
	Troubleshooting Fault Analysis	11
<b>5</b>	<b>Diagrams</b>	<b>33</b>
	<b>Limited Warranty</b>	<b>Insert</b>

---

# Preface

The Belshaw BX Smartbake convection oven is a computerized, compact, electric oven with a capacity for either four or 10 trays. Each tray is 26" x 18".

The convection oven is made of stainless steel and is fitted with a removable tray rack, allowing easy cleaning of its internal surfaces.

The 4-tray oven is designed to be stackable without separate support, allowing the system to grow with your business without taking up a large area.

The 10-tray oven is equipped with an integral, energy efficient steam system. A double glazed door also helps to increase energy efficiency, and the oven base is supplied with locking castors.

The high-speed fan and ring element provides efficient air circulation, helping produce a range of high-quality products.

To help ensure safe and efficient operation of the oven, the operator must work safely at all times, read this manual, and follow its instructions and warnings. A thorough understanding of how to install, maintain, and safely operate the convection oven will help prevent production delays and injuries.

To use the convection oven safely, heed the following warnings and all other warnings that appear in this manual.

- Use the oven only for baking bread, confectionery, and savory products. Do not use for any other items without consulting Belshaw.
- All repairs and maintenance of electrical units must be done by authorized electricians.

- Electrical access panels must not be opened unless the main supply to the oven is isolated.
- Any chimneys or ducts fitted above the ovens should be insulated.
- All connections must be made in accordance with the regulations of the country where the oven is installed.
- Do not touch the oven, its windows, or immediate surroundings during or shortly after use, as these surfaces may be hot.
- Use only Belshaw parts in this oven.
- Do not change the construction of this oven.
- The owner of the oven is legally obligated to instruct staff using the oven in its operation and in these safety regulations. The instructions must stay in the oven's working area.
- This oven uses a steam generator. Hard water must be properly treated before use.

# Installation

1

## Unpacking the oven

1. Move the crate containing the oven to the workstation.
2. Remove the machine from the shipping crate, being careful not to lose, loosen or damage any parts.
3. Remove all packing materials from the machine.

4. Inspect the machine to see that no parts have been damaged during shipping. If any damage has occurred, file a freight claim with the shipping company immediately.

### **IMPORTANT**

**Keep this manual available for future reference.**

## Dimensions and Specifications

	<b>2618 4 tray oven</b>	<b>2618 10 tray oven</b>
<b>Height</b>	21 inches	74 inches
<b>Depth, door closed, including handle</b>	44 inches	53.5 inches
<b>Width</b>	33.5 inches	33.5 inches
<b>Operational clearance*</b>	2" back and sides, 10" top	2" back and sides, 10" top
<b>Total power</b>	7.5 kW	17 kW
<b>Electric</b>	208 V, 3-phase + N + E, 60Hz, fused at 35A	208 V, 3-phase +N + E, 60Hz, fused at 58A
<b>Supply cable</b>	6 feet of cable provided	6 feet of cable provided
<b>Loading</b>	7 kW concentric ring element	16 kW (2 - 8 kW concentric ring elements)
<b>Fan drive</b>	Direct to motor	Direct to motor
<b>Tray size</b>	26" x 18"	26" x 18"
<b>Tray capacity</b>	4	5, 9, or 10
<b>Damper</b>	Butterfly type	Butterfly type
<b>Noise level</b>	Less than 85 dB	Less than 85 dB

\* Operational clearance is the amount of space required at the back, sides, and top of the oven to allow adequate air circulation.

Belshaw Bros., Inc. • 1750 22<sup>nd</sup> Ave. S. • Seattle, WA 98144 • Phone 206-322-5474 • Fax 206-322-5425

## **Water Supply**

- The BX Smartbake oven is fitted with a steam generator. In areas with hard water, the water supply to the oven must be treated with an appropriate protecting water treatment device. It is the sole responsibility of the customer to provide and maintain an appropriate water treatment system.
- For stacked ovens, the water supply should be shut off by closing the shut-off valves. (See Figure 1-1)
- For non-stacked ovens, the water supply should be shut off at the nearest shut-off point.

The BX Smartbake oven needs the following for the water supply:

- ¾" BSP female thread on the oven.
- 3 foot-long hose with ¾" B.S.P. female fittings at both ends (included)
- Inline backflow valve (customer must provide and fit)
- 15-60 p.s.i. water pressure

## **Installation**

The BX oven should be connected to a local means of isolation.

- To stop the oven in an emergency, switch off at the wall isolator.

## **Initial Cleaning**

Carefully wipe the interior of the oven and all accessories with a clean cloth soaked in warm soapy water and allow the oven to dry completely.

### **IMPORTANT**

**When cleaning the inside of the 4-tray oven, be careful not to damage the control probe protruding from the upper corner of the chamber's rear wall.**

### **WARNING**

**Do not allow water to enter the control panel or rear access panel.**

### **WATER SUPPLY**

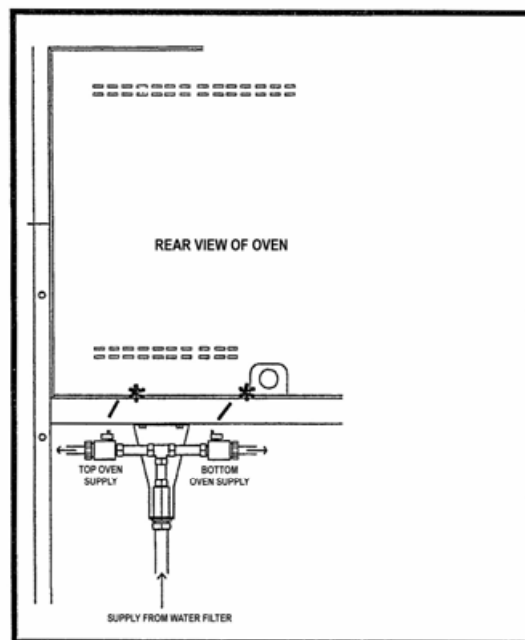

**\*Turn appropriate valve 90° counterclockwise to turn off water supply**

Figure 1-1. Turning off the water supply.



## Programming the control panel

The BX Smartbake oven is capable of storing 99 preset bake settings. To program these settings into the oven, follow these instructions.

1. Press the Stop button to get to the first screen (see Figure 1-2).

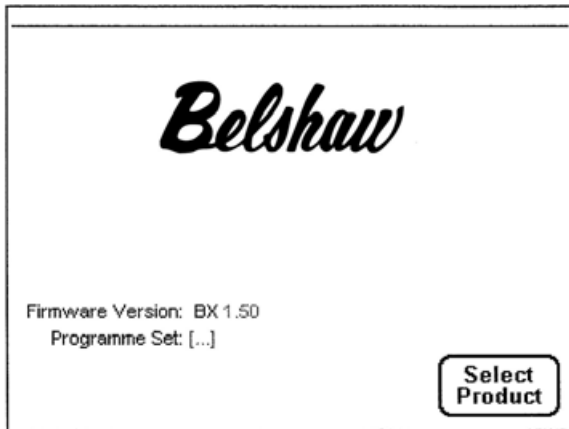

Figure 1-2

2. Press button 2 for the pass code screen (see Figure 1-3).

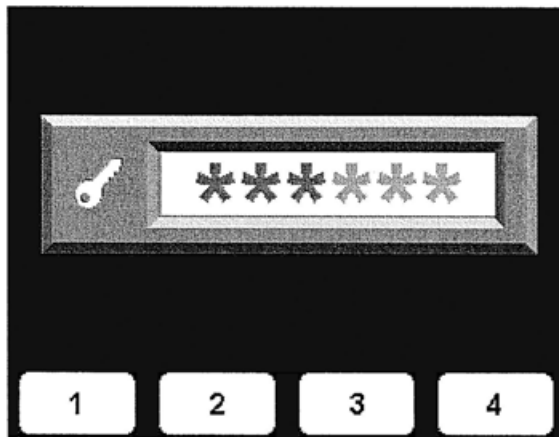

Figure 1-3

3. Enter the pass code using the numbered buttons (default is 11111). The following screen will appear (see Figure 1-4).

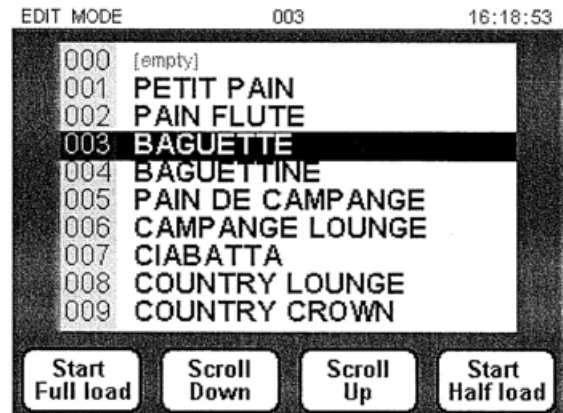
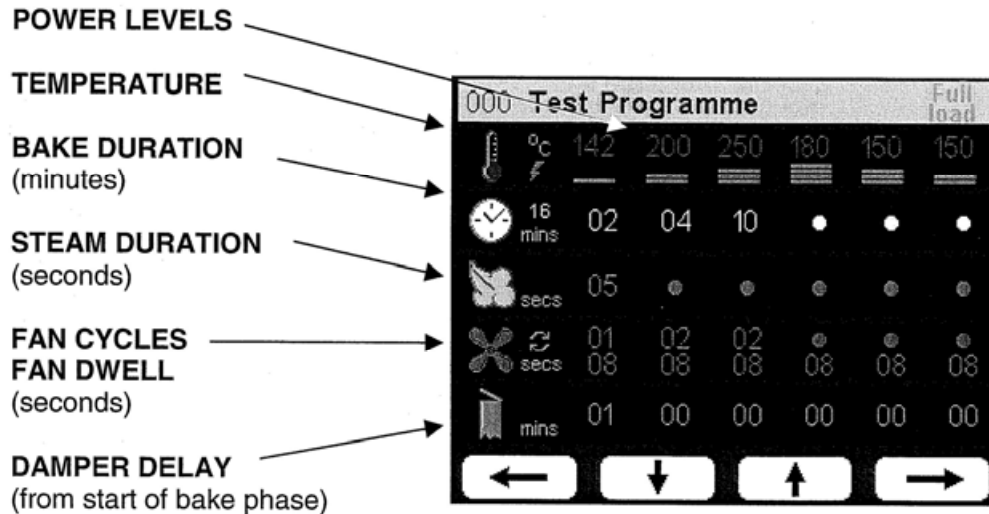

Figure 1-4

4. Press button 1 for full bake set-up or button 4 for ½ bake set-up. All parameters for the program can now be set.
5. The oven is capable of six different phases per bake, and if fewer are required, the time can be left at 0 to leave that phase inoperative.
  - To move across the screen, press button 4.
  - To move back, press button 1.
  - To increase the value of the parameter, press button 3.
  - To decrease the value of the parameter, press button 2.
6. Program Title: To set the program title, press button 6 to go up the alphabet and button 5 to go down the alphabet.

When all parameters are complete, press Stop three times to save the setting. Repeat this process for each program required.



## **Function of settings:**

**Power Levels:** Not used in current configuration.

**Temperature:** The temperature the oven will bake at for the specified phase. Can be set from 122° F to 482° F (50° C to 250° C)

**Bake Duration:** The length of time in minutes the oven will bake in the specified phase. For example, Phase 1 set at 2 min., Phase 2 set at 4 min., and Phase 3 set at 10 min. has a total bake time of 16 minutes.

**Steam Duration:** The length of time in seconds that steam will be injected into the oven at the beginning of the phase.

**Note:** Can be set from 0 to 20 seconds and will only operate if the temperature is above 250° F (120° C).

**Fan Cycles:** The number of times the fan will reverse rotation from clockwise to counterclockwise and back.

**Note:** Can be set from 0 to 9. Do not set the fan cycles number higher than 1 cycle per minute of bake time.

**Fan Dwell:** The amount of time in seconds that the fan will stay off during a rotation change.

**Note:** Can be set from 8 to 15.

**Note:** The heating elements are off during the Fan Dwell time.

**Damper Delay:** The amount of time in minutes the damper will wait before opening during one bake cycle.

**Note:**

- Can be set from 0 to 99.
- If this time is set higher than the total bake time, the damper will not open.
- The damper will only open once during a complete bake cycle and will close at the end of the bake cycle.

## Operating conditions

For the most efficient operation, the following instructions must be followed. Failure to comply with these guidelines may affect the warranty.

- The ambient temperature around the oven must not exceed 115° F (40° C).
- The ventilation around the oven should be enough to ensure that there is no condensation on or around the oven from steam.
- It is the customer's responsibility to arrange for adequate ventilation and operational clearance at the back and sides of the oven to allow circulation of air.

## Running Pre-set programs

1. Connect water ensuring there are no leaks.
2. Connect the power to a suitable outlet.
3. Turn on the oven by pressing the green button and the following screen will appear (Figure 2-1):

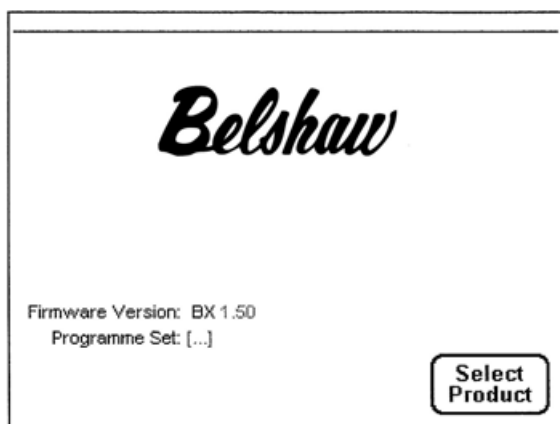

Figure 2-1

4. Press Button 4 (which corresponds to the “select product” option in Figure 2-1) and the program list will appear (Figure 2-2). If the oven has not been programmed, see the section on programming on page 3.

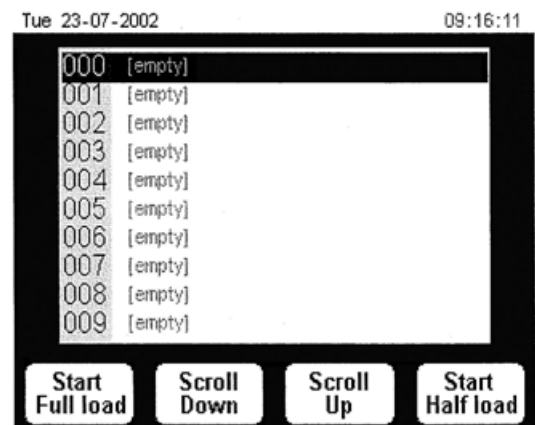

Figure 2-2

5. Highlight the desired program by pressing buttons 2, 3, 5, or 6 to scroll down, up, 10 down, or 10 up, respectively.
6. Start heating the oven by pressing button 4 for a ½ load bake or button 1 for a full load bake. The following screen will appear (Figure 2-3). To stop heating, press the stop/Back button at any time.

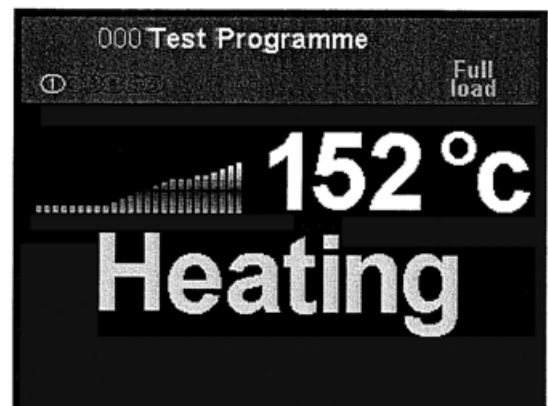

Figure 2-3

**WARNING**

Stand clear of the oven door when opening to avoid the hot steam and vapor. Hot steam or vapor may cause severe burns.

**WARNING**

Always preheat the oven to required temperature. Do not place product directly into a cold oven.

- 7. When the oven is ready, the following screen will appear (Figure 2-4). Load the product and press the button corresponding to the Start option (button 4).



Figure 2-4

- 8. When the bake time is over, the buzzer will sound and the screen will read “Bake Over” (Figure 2-5). Press stop and remove the product or press button 4 to extend the bake time by two minutes. The Stop button may be pressed at any time to stop the bake.



Figure 2-5

- 9. Upon pressing the Stop button, the screen will revert to the program screen (Figure 2-2).
- 10. To bake in a preheated oven, select a new program with keys 2 and 3. Then follow instructions 6-8.

**NOTE**

During heating, button 1 can be pressed at any time to check the settings. Press button 1 again or wait 10 seconds to return to the previous screen.

**NOTE**

Until the oven is up to the target temperature, the display will show “Heating;” then the display will show “Ready” and the oven will stay at the target temperature until baking starts or another program is selected.

# Cleaning and Maintenance 3

## **Daily Cleaning**

1. Disconnect the oven from main power supply and allow to cool completely before cleaning.
2. Use only approved chloride-free cleaning fluid for daily cleaning.
3. Sweep any debris (after the oven has been allowed to cool) onto removable oven trays and remove for cleaning.
4. Brush down and wipe oven front, back, and sides.
5. Carefully clean the oven with a damp cloth that has been soaked in a solution of mild detergent and hot water, being extra careful around control switches. In the 4-tray oven, be sure the control probe protruding from the upper rear corner inside the oven is not damaged (see page 9).
6. Do not let any liquid enter the control panel or rear access panel.
7. Do not remove the rear paneling inside the oven. This allows access to the fan assembly, which is not safety interlocked and could cause injury.
8. Dry completely.

## **Weekly Cleaning**

1. Complete the daily cleaning.
2. Carefully clean off any burnt-on debris using an appropriate oven cleaner, following the manufacturer's instructions. **Do not allow the oven cleaner to get in the control panel.**
3. Scrub the cabinet wheels (if fitted) with a mild detergent and hot water, using a nylon cleaning brush.

4. Open the oven door and remove the internal racking from the sides of the oven by lifting and unlatching the racking. Wipe the interior of the oven with a damp cloth.
5. On the BX-4, open the inner door glass by removing two screws shown in Figure 3-1. The glass is hinged to allow a more thorough cleaning.

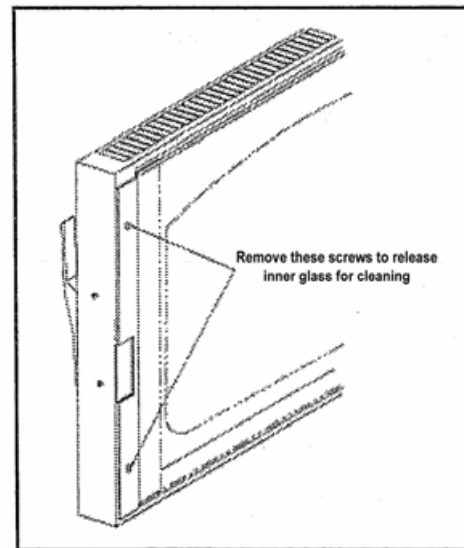

Figure 3-1. Removing the inner door glass (BX-4 only).

6. Clean the glass with a suitable glass cleaner.
7. Wipe down the oven and clean the racking with a damp cloth.
8. Reassemble all parts back in the oven after cleaning.

---

## WARNING

**In the 4-tray oven, do not damage the control probe protruding from the upper corner of the inside rear wall of the oven chamber.**

## WARNING

**Make sure water does not enter the control panel or rear access panel.**

## WARNING

**Do not remove the rear paneling inside the oven. This allows access to the fan assembly and could cause injury.**

- If the steaming operation deteriorates, clean the pipe aperture with a pin to remove any build-up.

## Lubrication

This machine does not require special lubrication.

## Maintenance

- Check for frayed or bare cables. The machine must not be used if there are frayed or bare cables.
- Follow cleaning instructions exactly.
- Check condition of the rubber door seal. Repair or replace if necessary.
- If the light bulb burns out, use the following instructions to replace it.
  - a. Disconnect the oven from the main power supply and allow to cool.
  - b. Remove the glass front from the lamp unit.
  - c. Remove the bulb by unscrewing counterclockwise and replace with a new bulb.
  - d. Refit the glass front.
  - e. Reconnect the oven to the main power supply and test the lights.

IF YOU HAVE ANY QUESTIONS - ASK

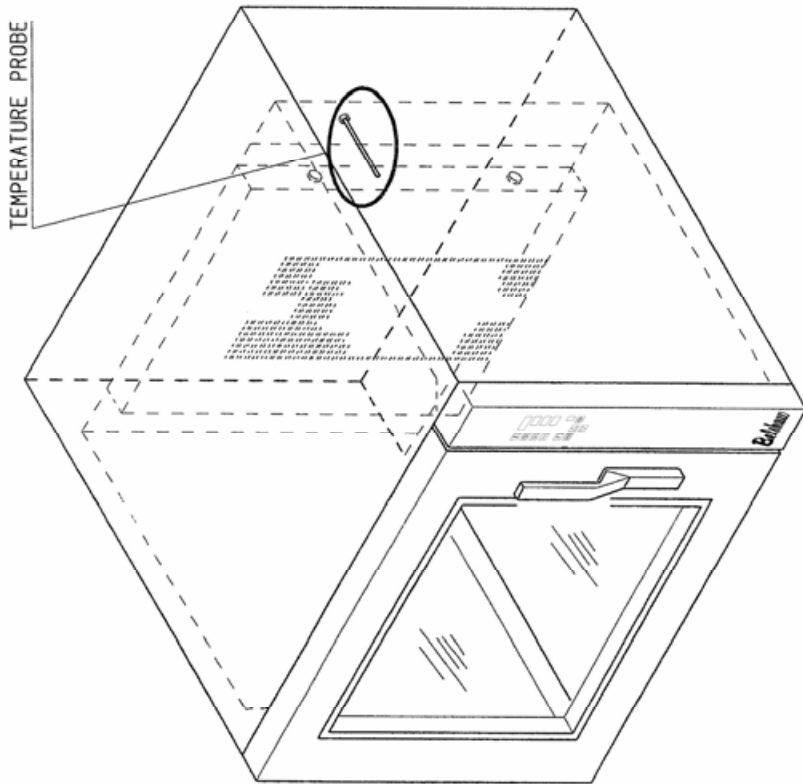

TEMPERATURE PROBE

TEMPERATURE PROBE

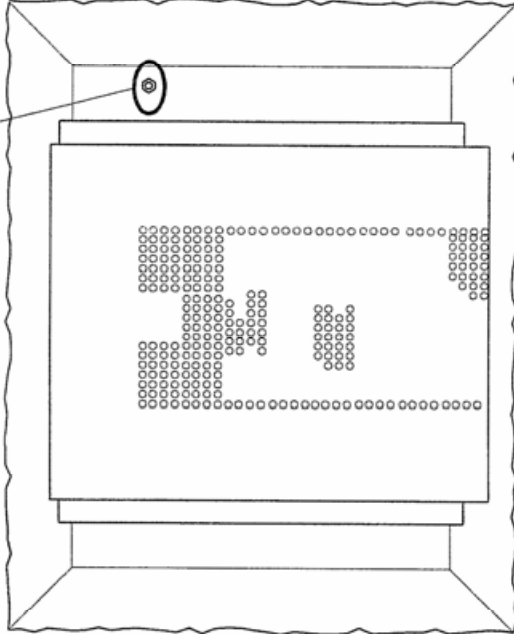

VIEW LOOKING INSIDE OVEN CHAMBER  
(WITH RUNNERS REMOVED)

**IMPORTANT WARNING!**

CARE MUST BE TAKEN WHEN CLEANING AROUND THE TEMPERATURE PROBE.  
(IF ANY DAMAGE OCCURS TO THE TEMPERATURE PROBE  
IT MUST BE REPLACED BEFORE ANY FURTHER COOKING OPERATIONS)

COPYRIGHT © 1988 - THIS DESIGN/DRAWING IS THE PROPERTY OF BELSHAW BROS., INC. AND MUST NOT BE REPRODUCED, COPIED, NOR ITS CONTENTS BE DIVULGED WITHOUT PRIOR WRITTEN PERMISSION.

REV	SIG	DATE	REVISION	ECN NO.
				
1750 22nd Ave. S. Seattle, WA 98144 Tel: 206-322-5474 1-800-578-2547 Fax: 206-322-5425 E-mail: service@belshaw.com				
TITLE: <b>BX CLEANING INSTRUCTIONS</b> (SHOWING THERMOCOUPLE PROBE POSITION)			ELECTRICALLY APPROVED BY:- S.P.	
ELECTRICAL SPECIFICATIONS:-			DRAWING NO. ME791	
DATE: 21-2-98			REV: -	

---

# Troubleshooting

4

The following pages contain troubleshooting/  
fault analysis charts for the Classic convection  
oven.



## 4 TRAY & 10 TRAY SMARTBAKE FAULT ANALYSIS CHART

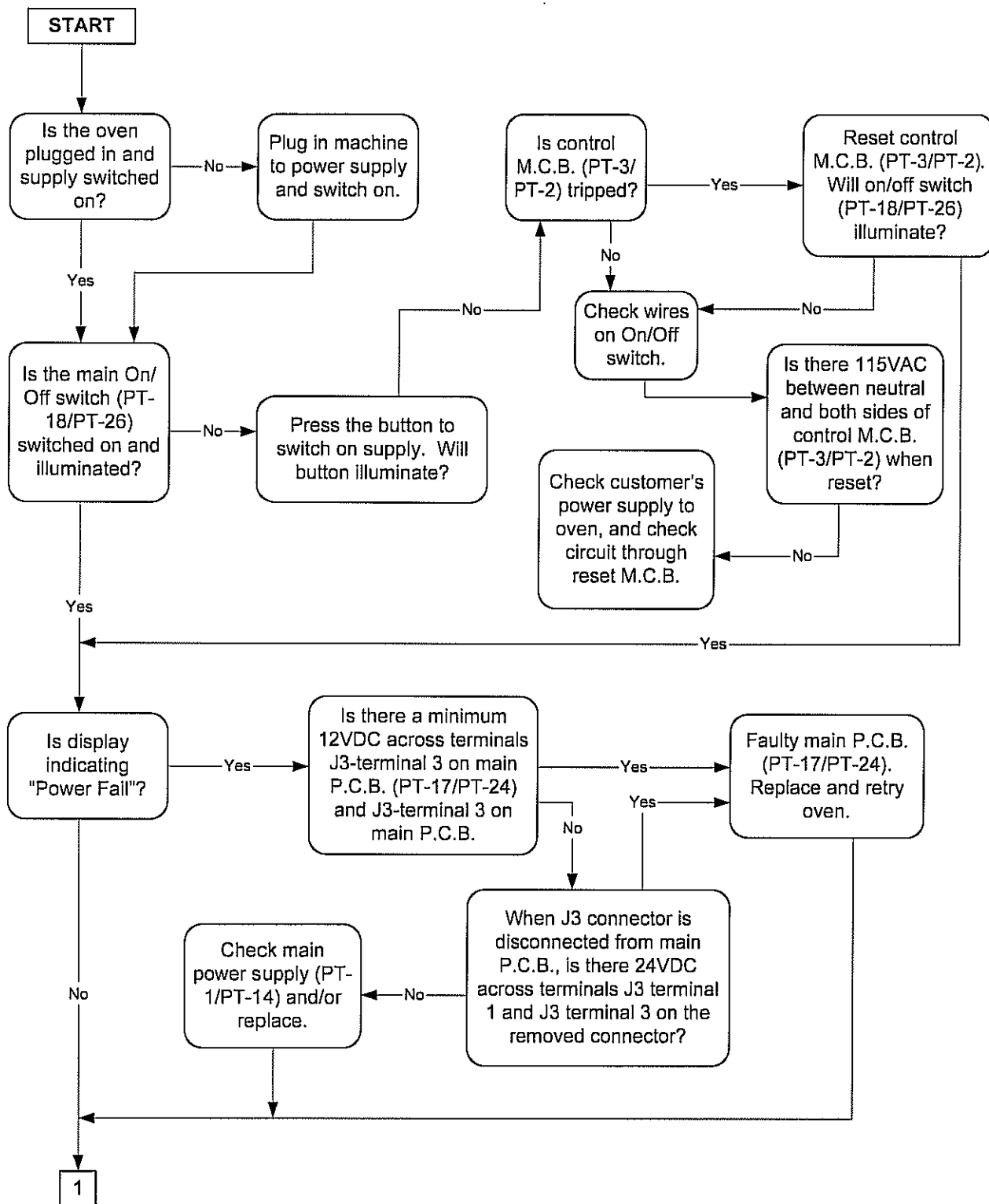

\*Note: Part (PT) numbers are indicated in parentheses; 4-tray oven PT numbers are listed first, then 10-tray oven PT numbers unless otherwise indicated.

## 4 TRAY & 10 TRAY SMARTBAKE FAULT ANALYSIS CHART

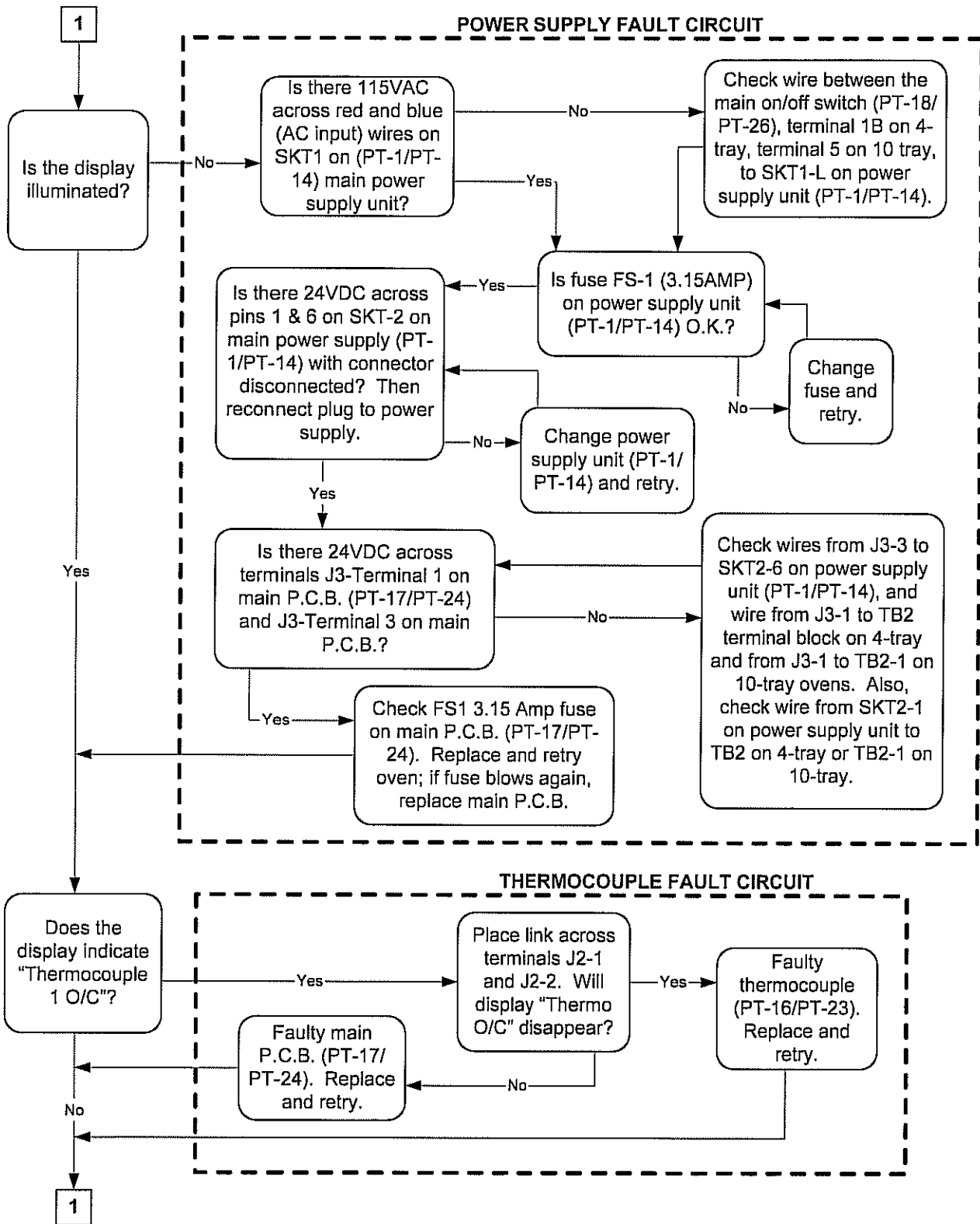

\*Note: Part (PT) numbers are indicated in parentheses; 4-tray oven PT numbers are listed first, then 10-tray oven PT numbers unless otherwise indicated.

## 4 TRAY & 10 TRAY SMARTBAKE FAULT ANALYSIS CHART

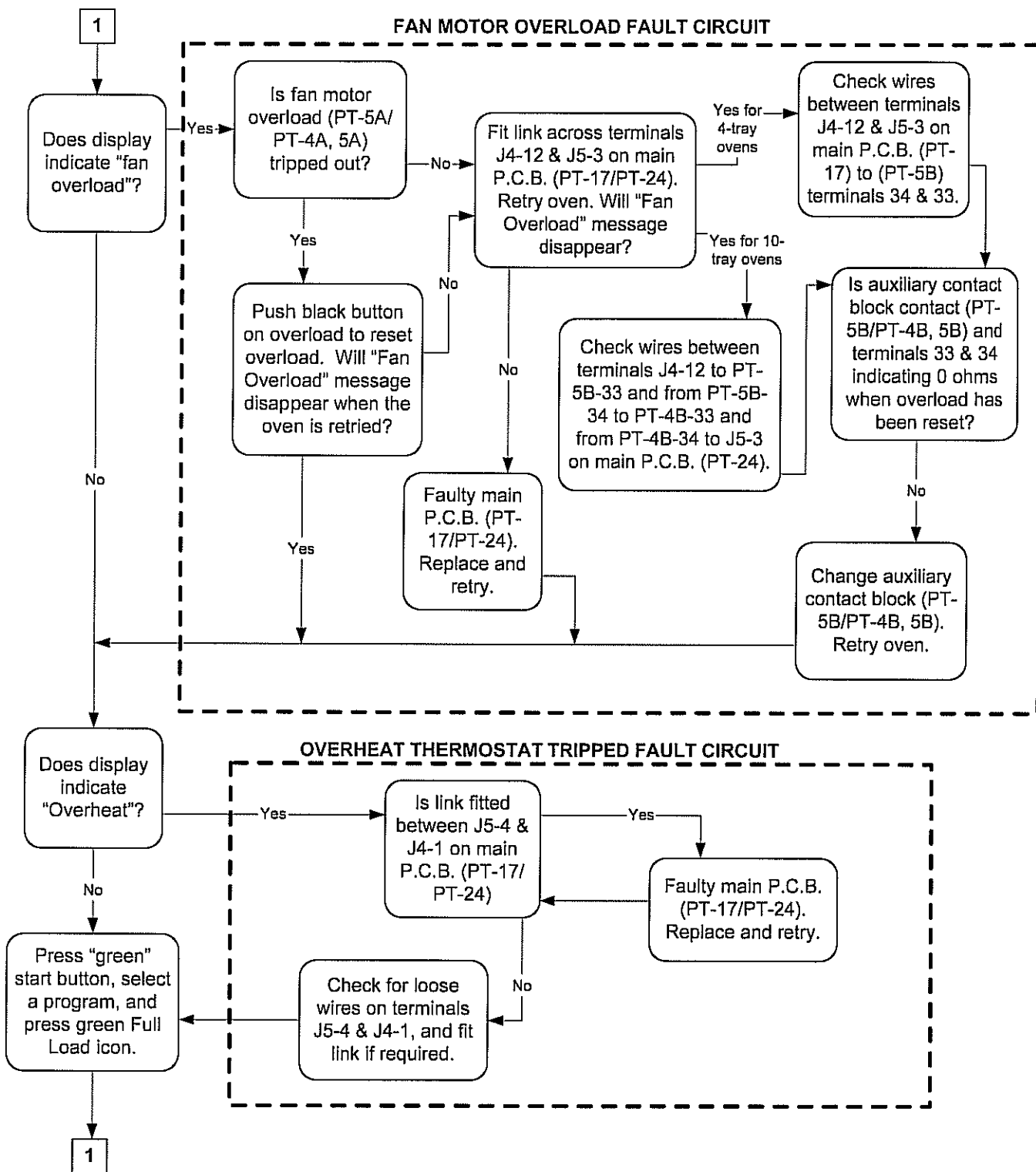

\*Note: Part (PT) numbers are indicated in parentheses; 4-tray oven PT numbers are listed first, then 10-tray oven PT numbers unless otherwise indicated.

## 4 TRAY & 10 TRAY SMARTBAKE FAULT ANALYSIS CHART

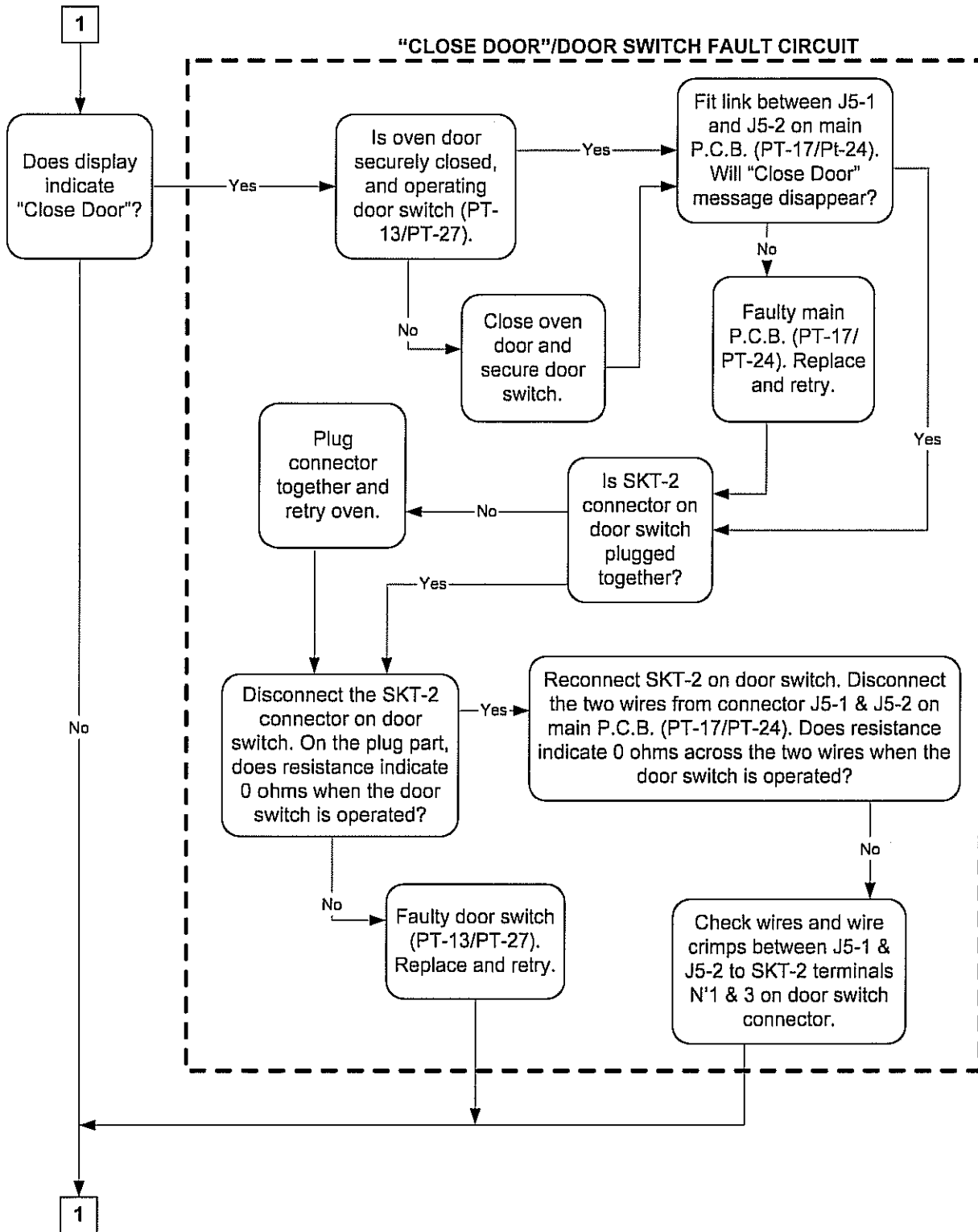

\*Note: Part (PT) numbers are indicated in parentheses; 4-tray oven PT numbers are listed first, then 10-tray oven PT numbers unless otherwise indicated.

## 4 TRAY & 10 TRAY SMARTBAKE FAULT ANALYSIS CHART

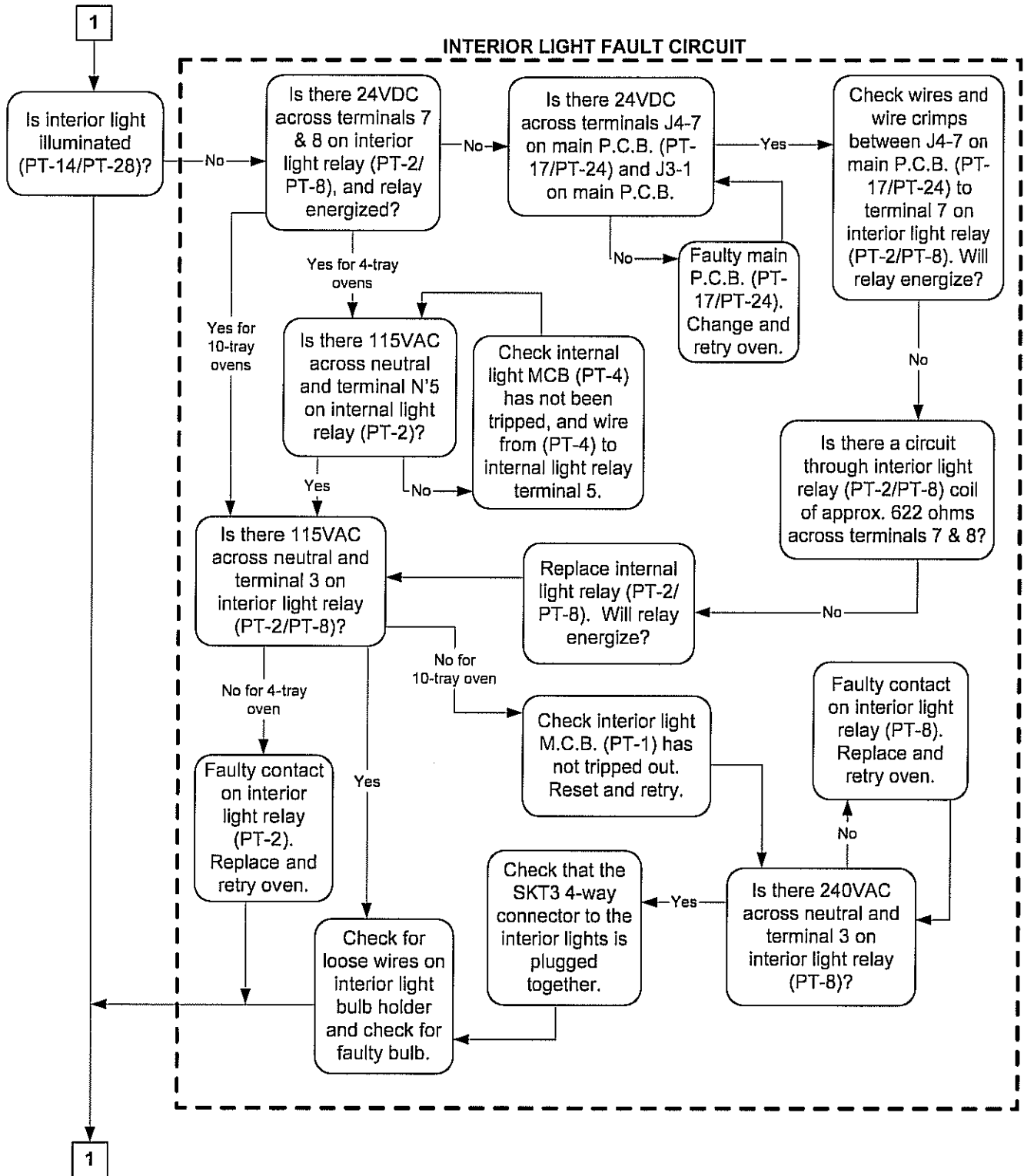

\*Note: Part (PT) numbers are indicated in parentheses; 4-tray oven PT numbers are listed first, then 10-tray oven PT numbers unless otherwise indicated.

## 4 TRAY & 10 TRAY SMARTBAKE FAULT ANALYSIS CHART

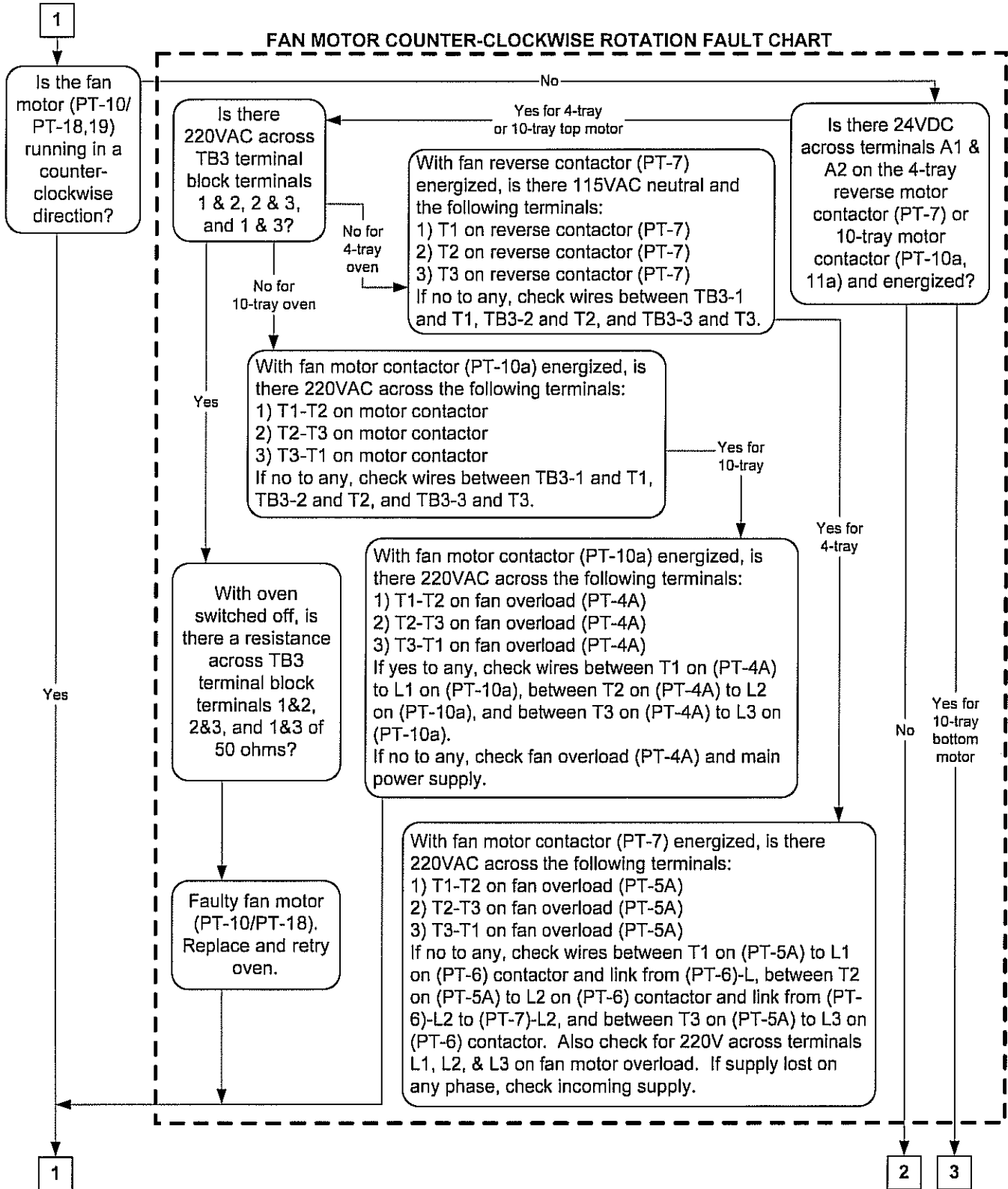

\*Note: Part (PT) numbers are indicated in parentheses; 4-tray oven PT numbers are listed first, then 10-tray oven PT numbers unless otherwise indicated.

## 4 TRAY & 10 TRAY SMARTBAKE FAULT ANALYSIS CHART

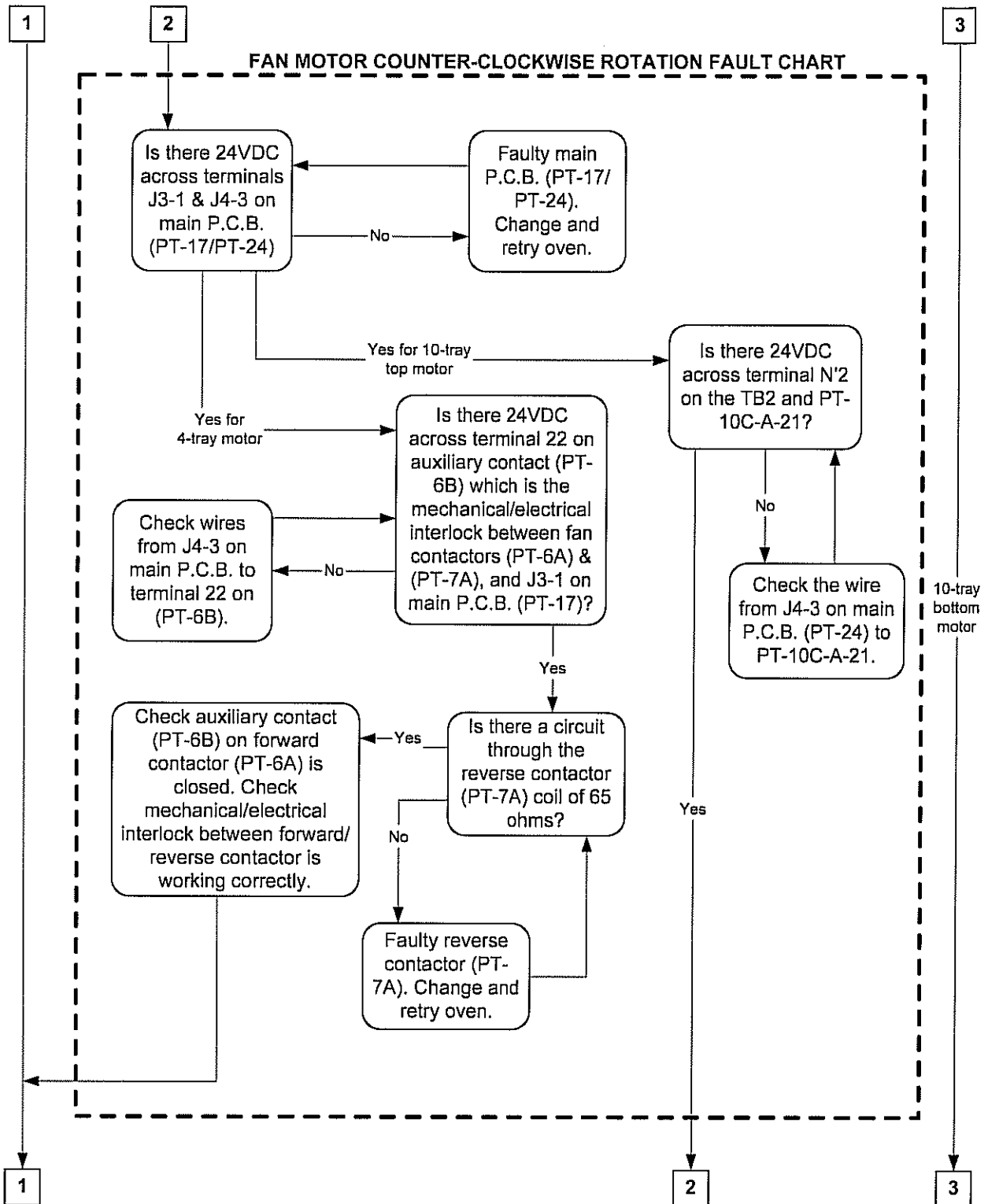

\*Note: Part (PT) numbers are indicated in parentheses; 4-tray oven PT numbers are listed first, then 10-tray oven PT numbers unless otherwise indicated.

## 4 TRAY & 10 TRAY SMARTBAKE FAULT ANALYSIS CHART

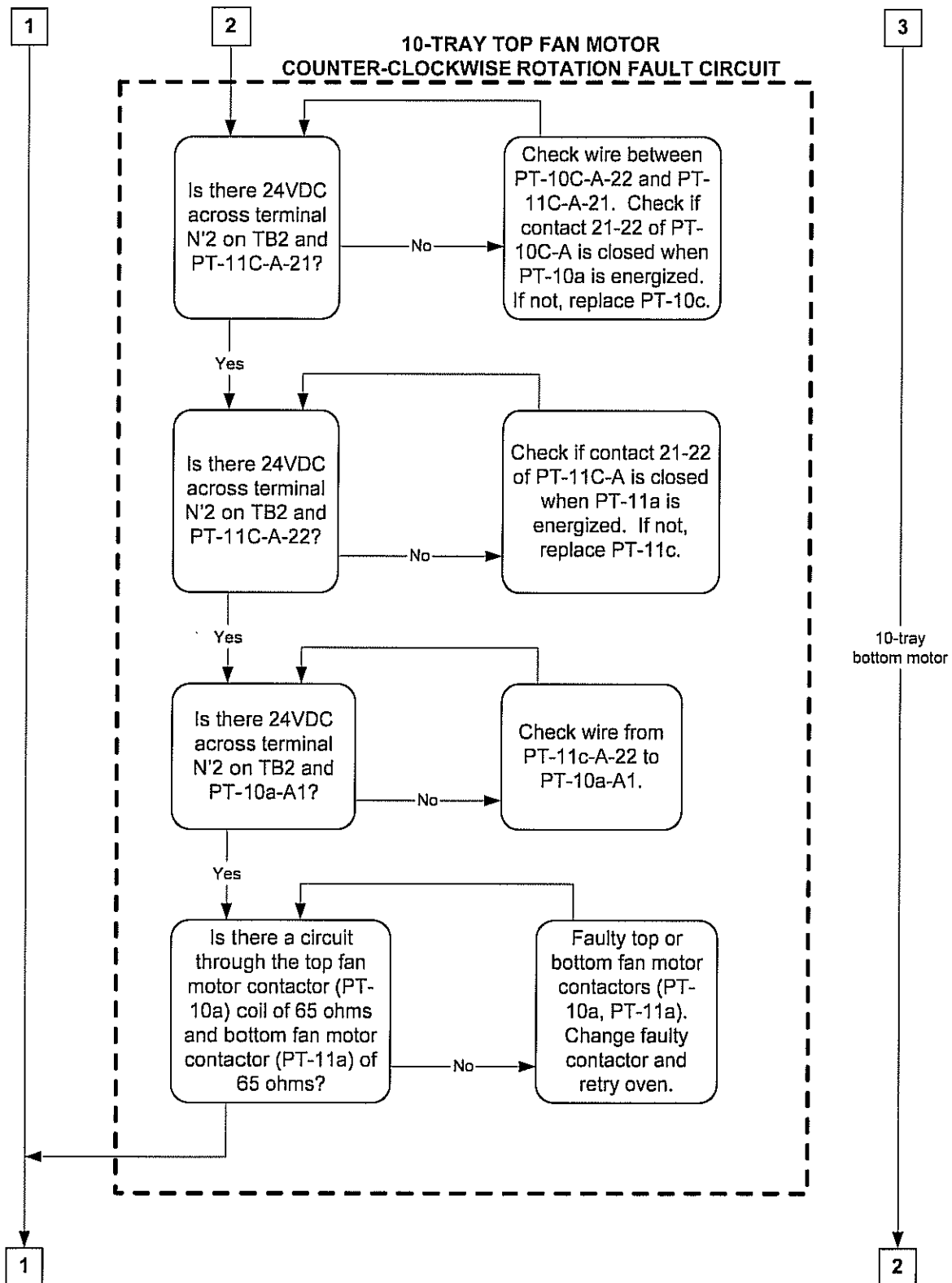

\*Note: Part (PT) numbers are indicated in parentheses; 4-tray oven PT numbers are listed first, then 10-tray oven PT numbers unless otherwise indicated.



## 4 TRAY & 10 TRAY SMARTBAKE FAULT ANALYSIS CHART

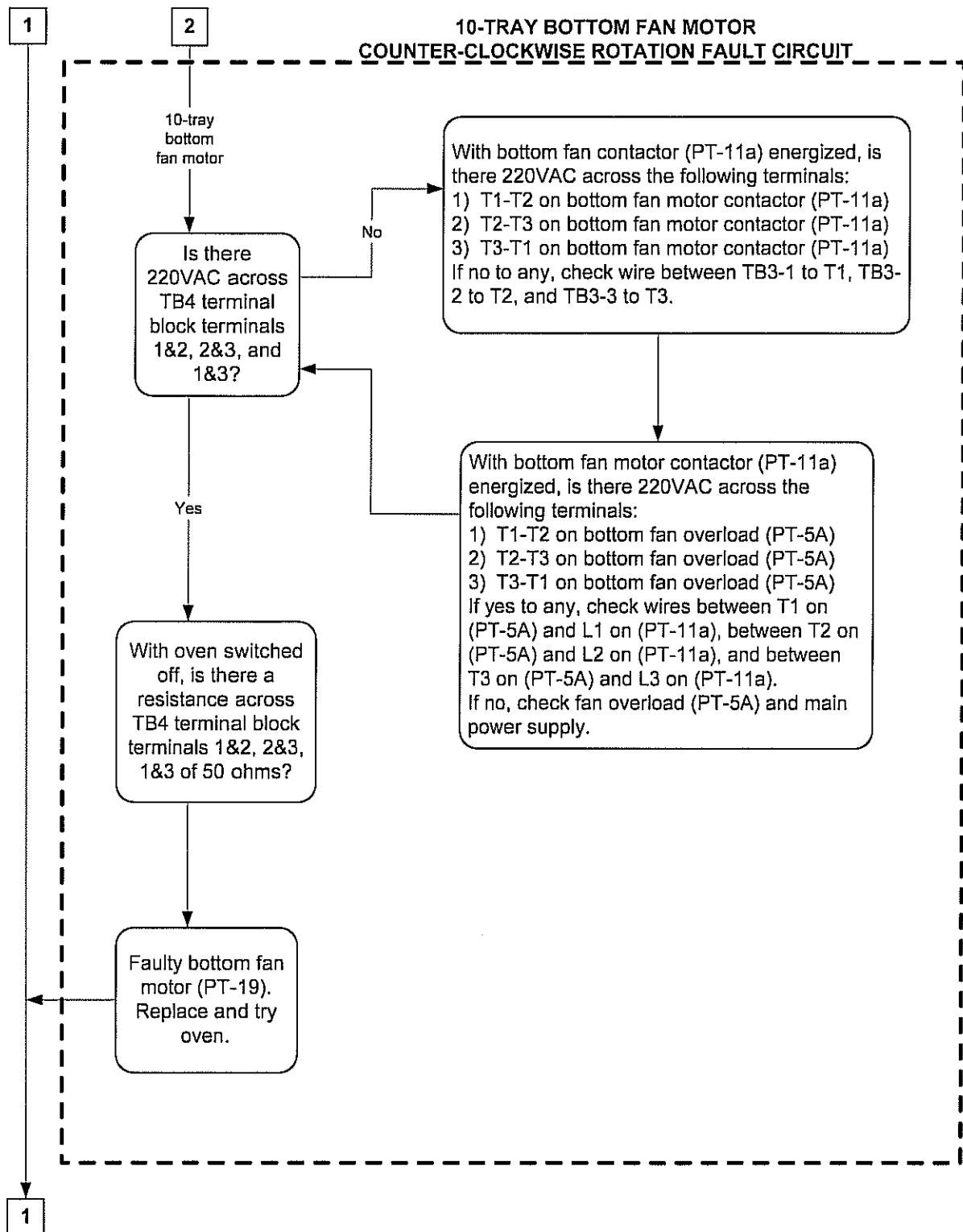

\*Note: Part (PT) numbers are indicated in parentheses; 4-tray oven PT numbers are listed first, then 10-tray oven PT numbers unless otherwise indicated.

## 4 TRAY & 10 TRAY SMARTBAKE FAULT ANALYSIS CHART

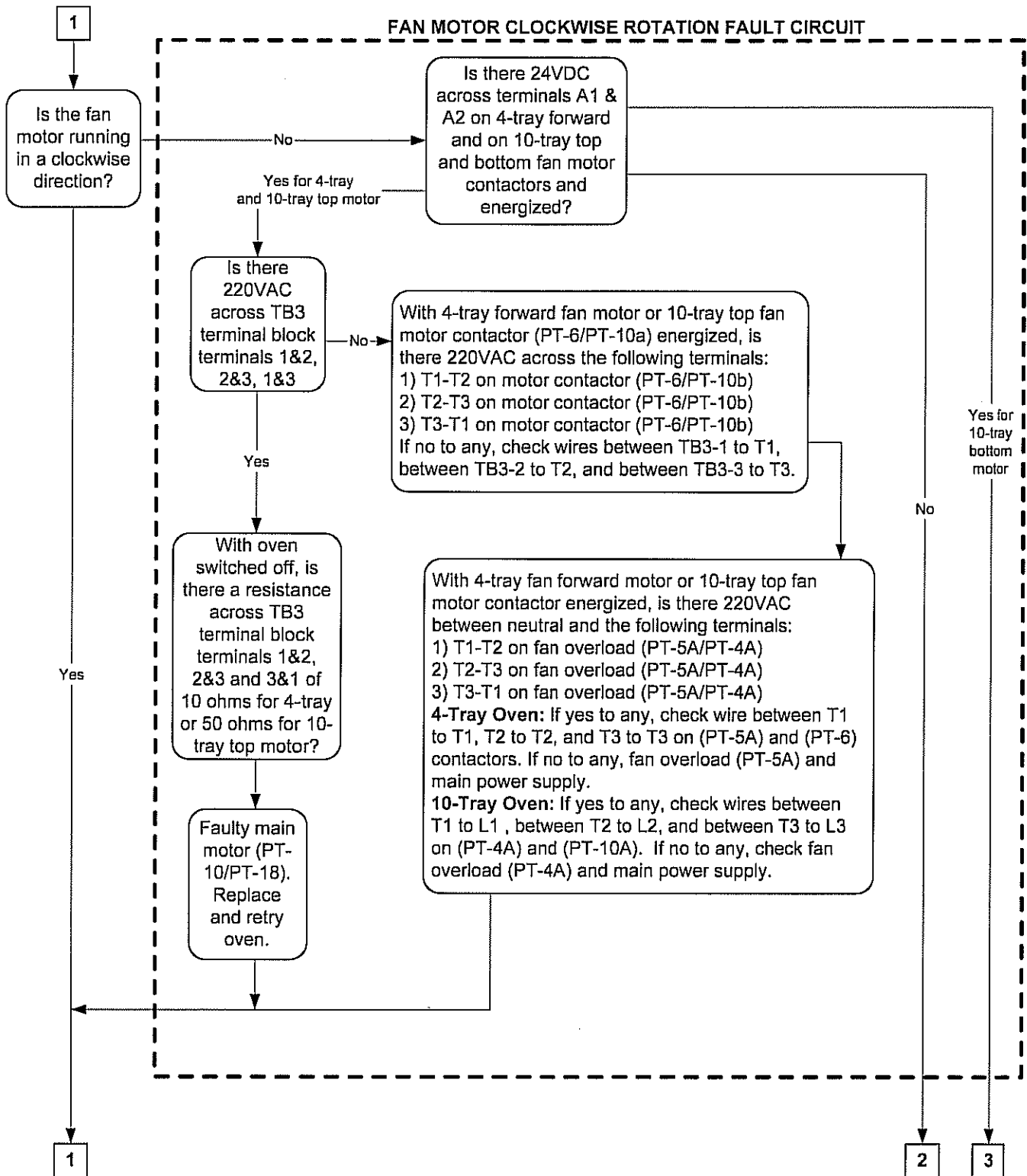

\*Note: Part (PT) numbers are indicated in parentheses; 4-tray oven PT numbers are listed first, then 10-tray oven PT numbers unless otherwise indicated.

## 4 TRAY & 10 TRAY SMARTBAKE FAULT ANALYSIS CHART

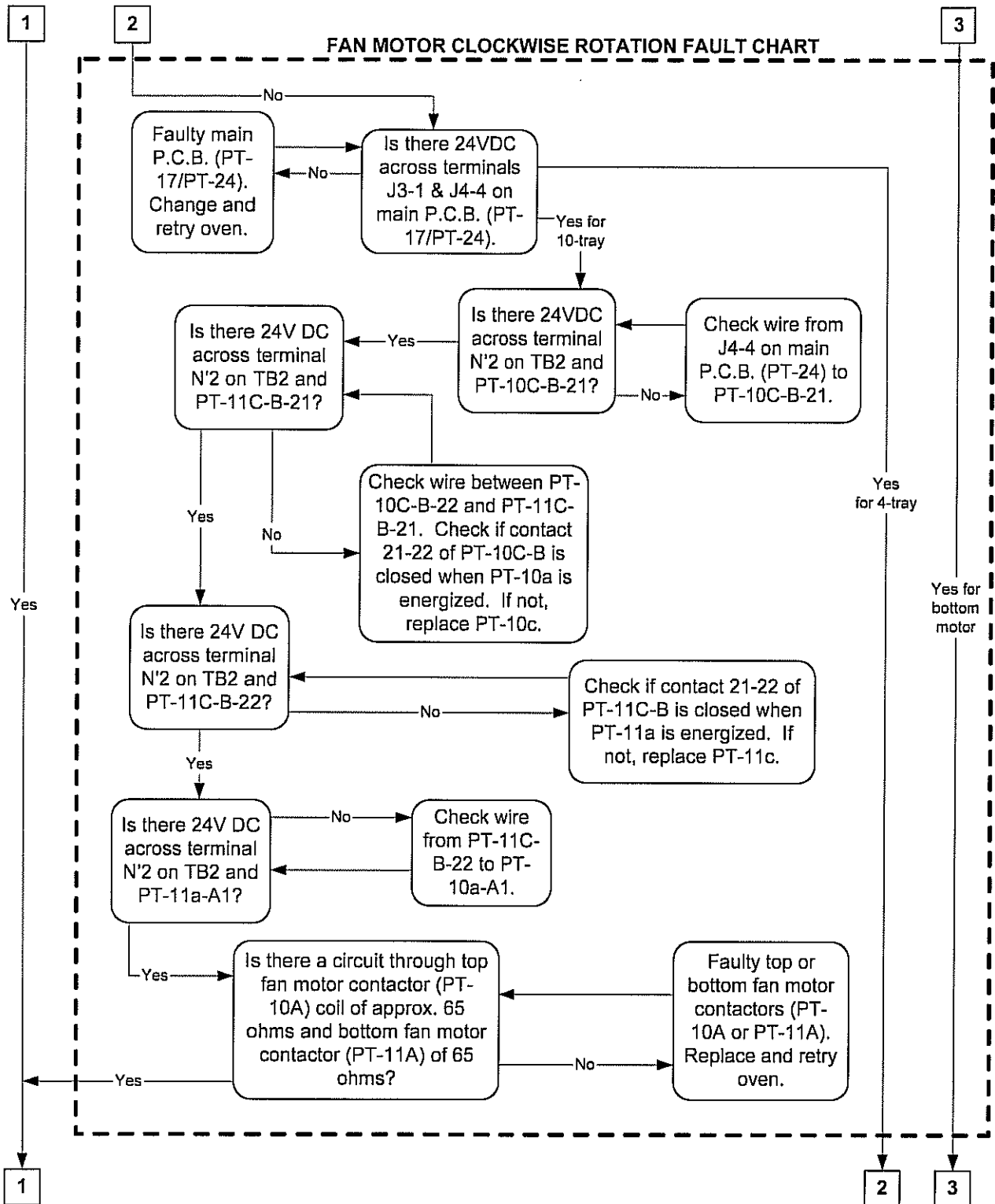

\*Note: Part (PT) numbers are indicated in parentheses; 4-tray oven PT numbers are listed first, then 10-tray oven PT numbers unless otherwise indicated.

## 4 TRAY & 10 TRAY SMARTBAKE FAULT ANALYSIS CHART

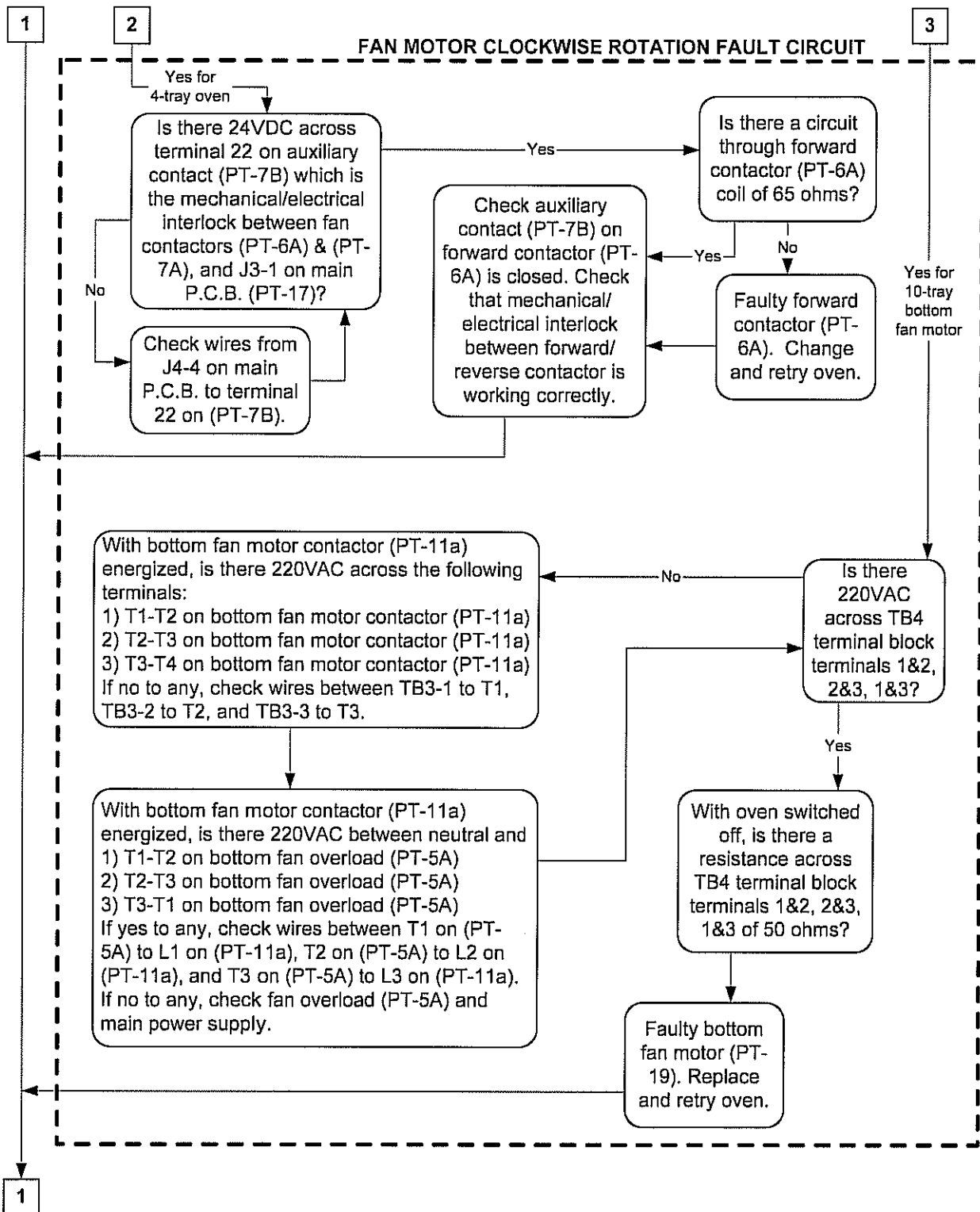

\*Note: Part (PT) numbers are indicated in parentheses; 4-tray oven PT numbers are listed first, then 10-tray oven PT numbers unless otherwise indicated.



## 4 TRAY & 10 TRAY SMARTBAKE FAULT ANALYSIS CHART

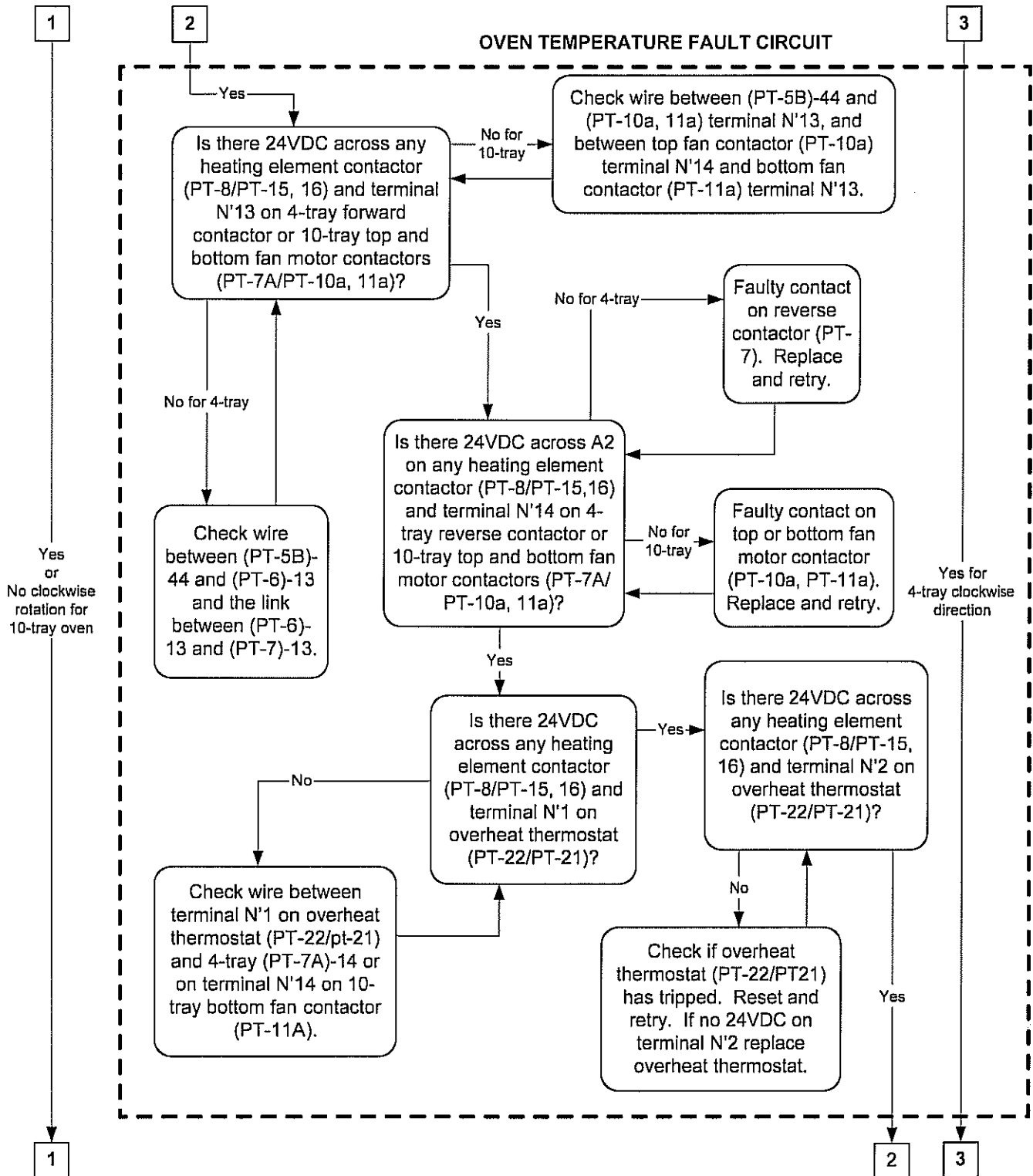

\*Note: Part (PT) numbers are indicated in parentheses; 4-tray oven PT numbers are listed first, then 10-tray oven PT numbers unless otherwise indicated.

## 4 TRAY & 10 TRAY SMARTBAKE FAULT ANALYSIS CHART

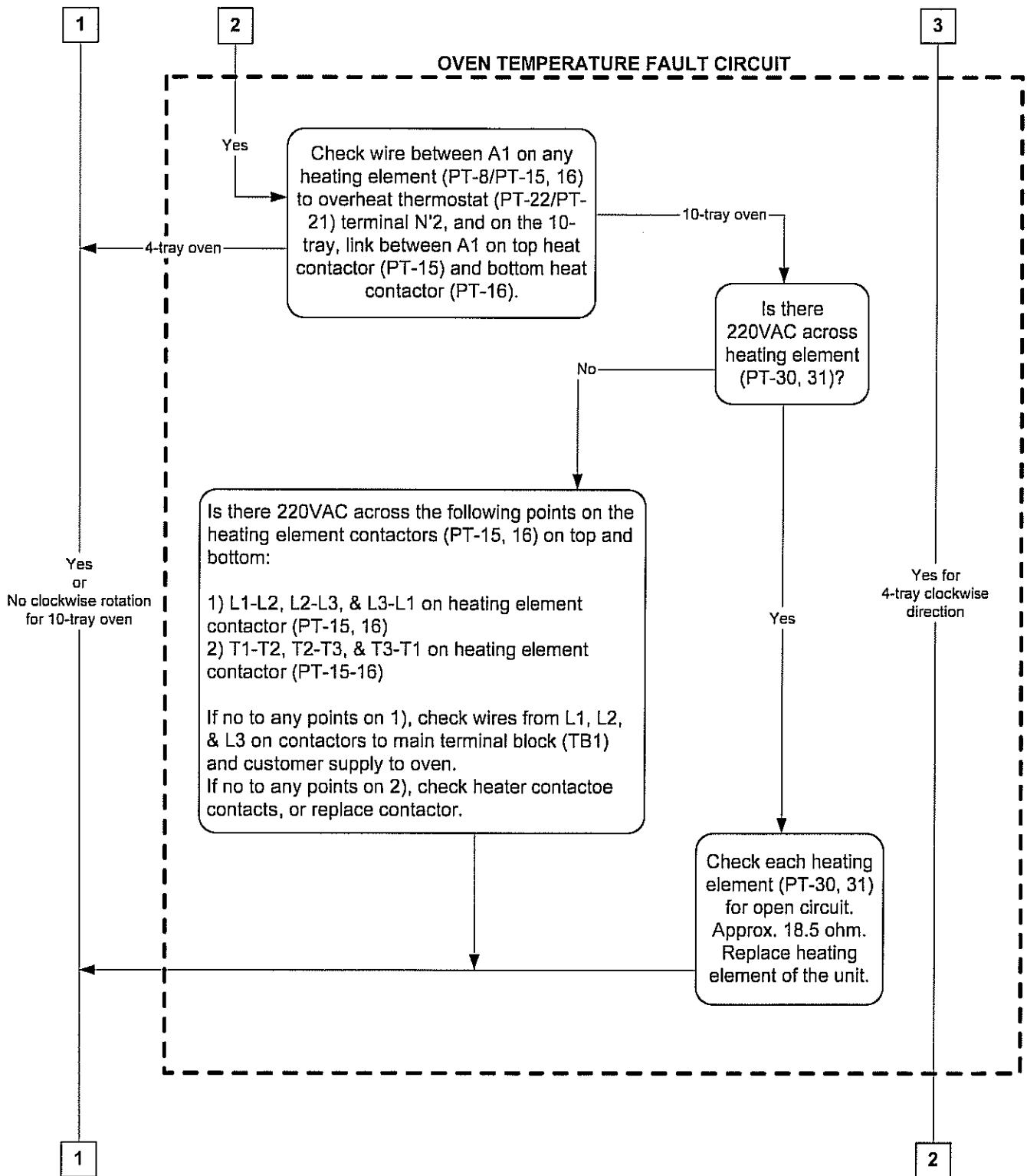

\*Note: Part (PT) numbers are indicated in parentheses; 4-tray oven PT numbers are listed first, then 10-tray oven PT numbers unless otherwise indicated.

## 4 TRAY & 10 TRAY SMARTBAKE FAULT ANALYSIS CHART

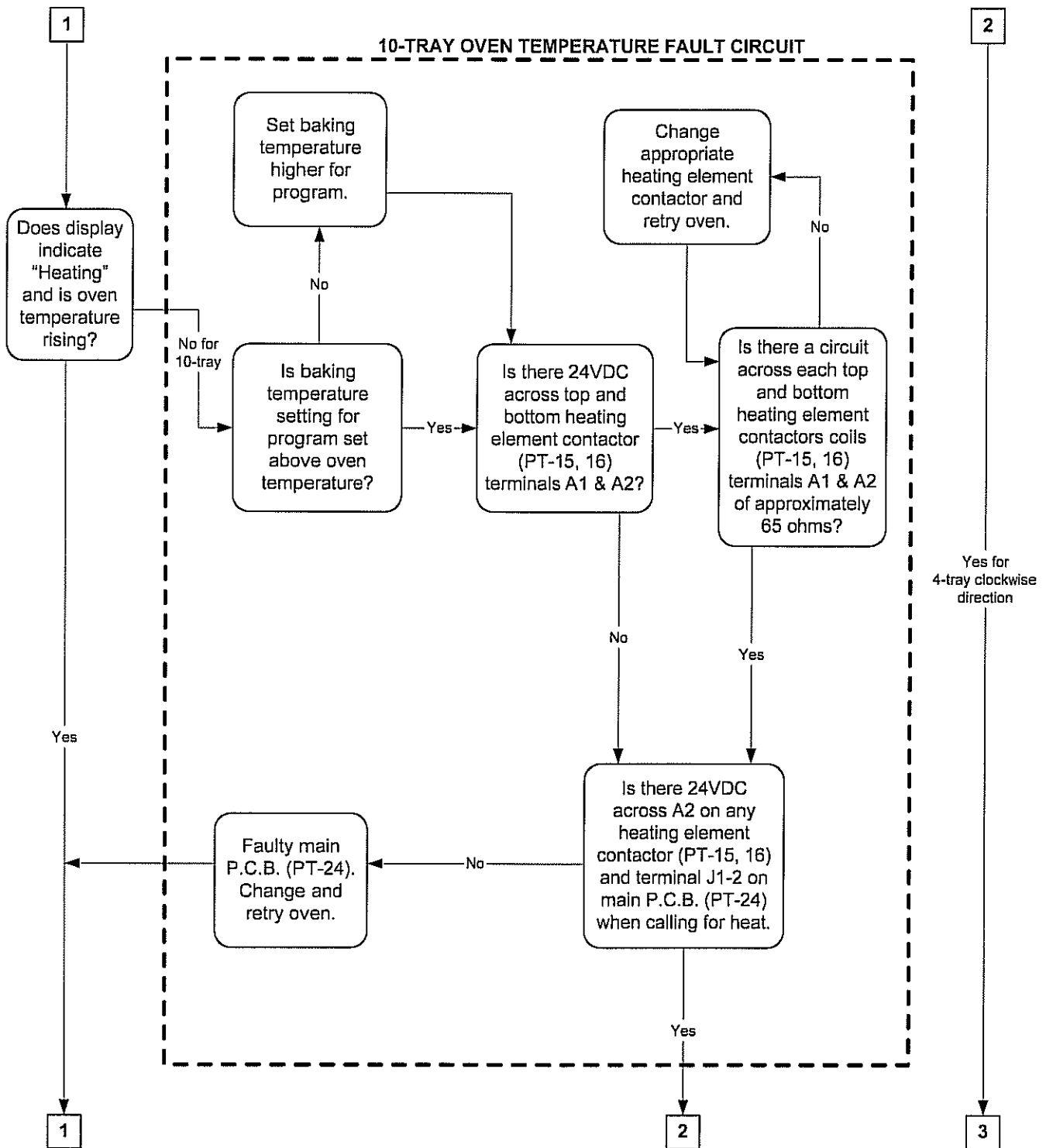

\*Note: Part (PT) numbers are indicated in parentheses; 4-tray oven PT numbers are listed first, then 10-tray oven PT numbers unless otherwise indicated.



## 4 TRAY & 10 TRAY SMARTBAKE FAULT ANALYSIS CHART

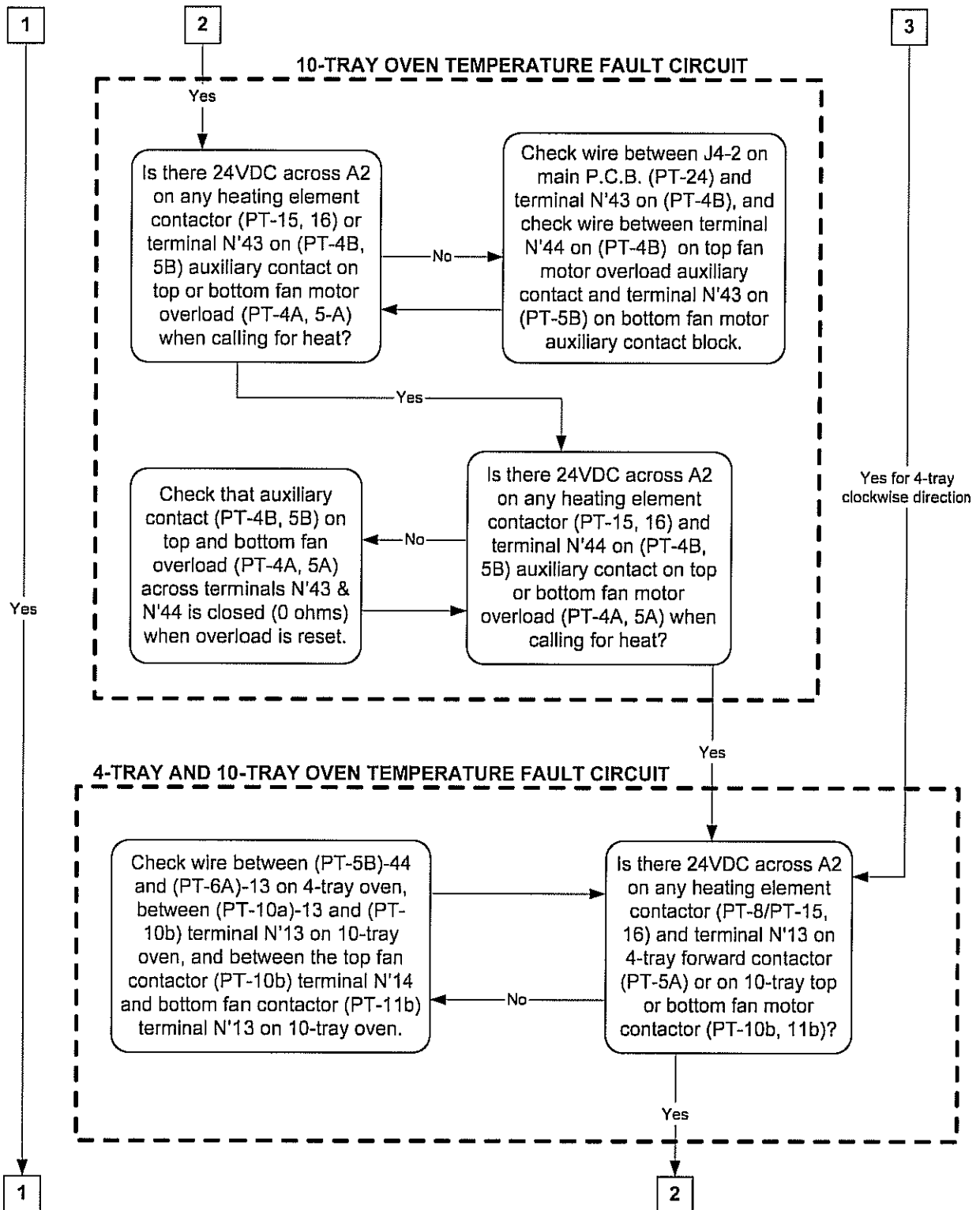

\*Note: Part (PT) numbers are indicated in parentheses; 4-tray oven PT numbers are listed first, then 10-tray oven PT numbers unless otherwise indicated.

## 4 TRAY & 10 TRAY SMARTBAKE FAULT ANALYSIS CHART

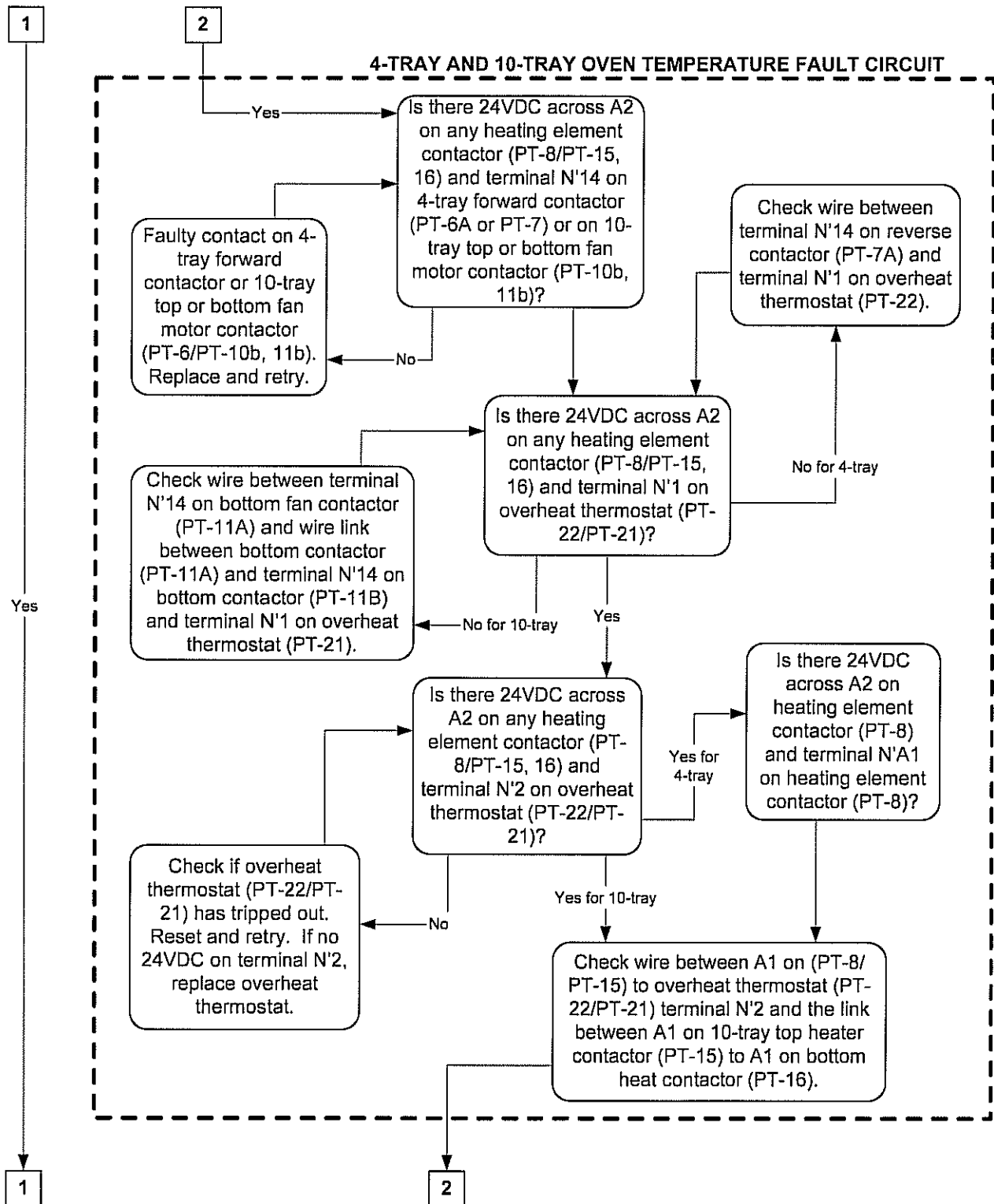

\*Note: Part (PT) numbers are indicated in parentheses; 4-tray oven PT numbers are listed first, then 10-tray oven PT numbers unless otherwise indicated.

## 4 TRAY & 10 TRAY SMARTBAKE FAULT ANALYSIS CHART

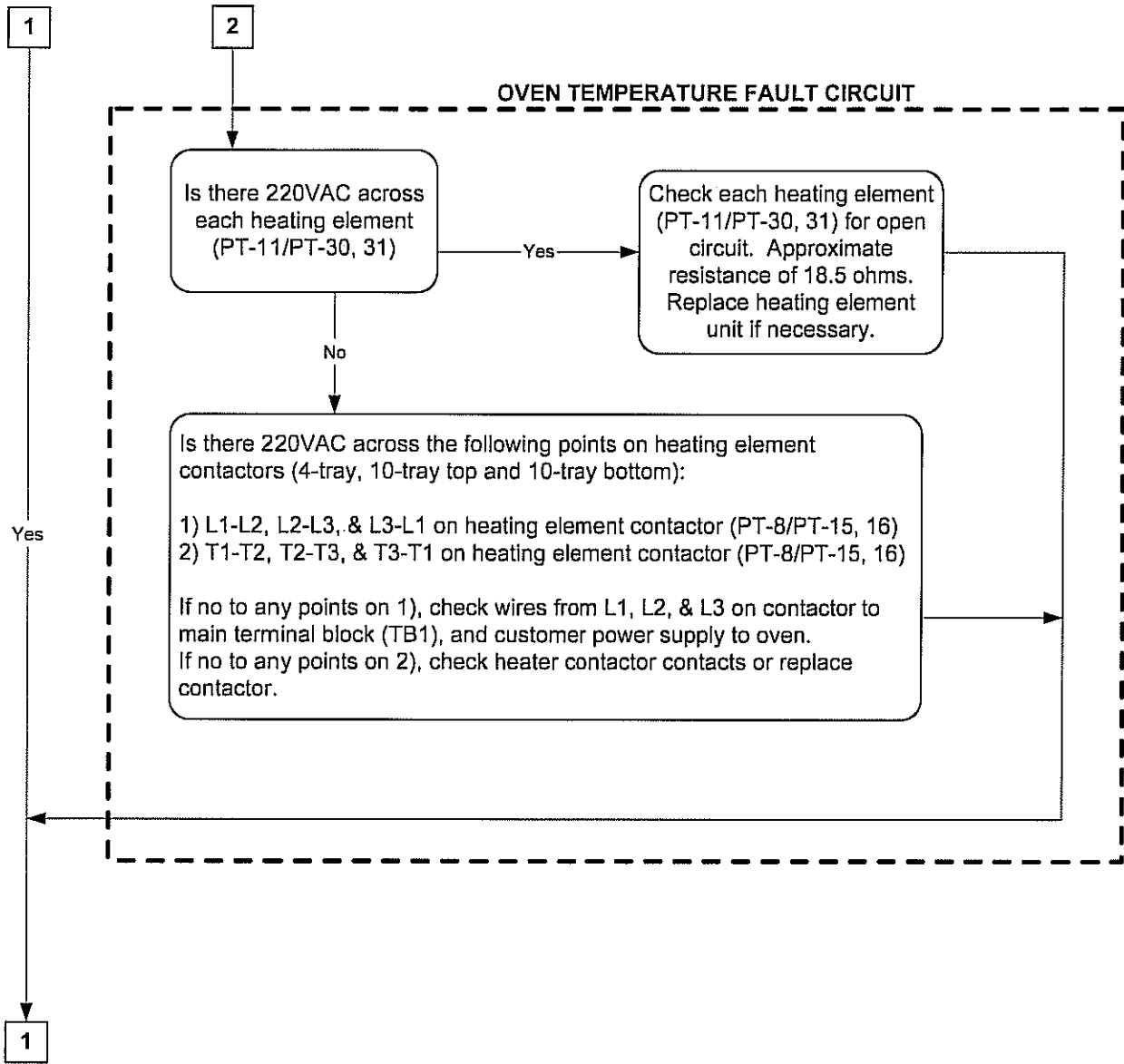

\*Note: Part (PT) numbers are indicated in parentheses; 4-tray oven PT numbers are listed first, then 10-tray oven PT numbers unless otherwise indicated.

## 4 TRAY & 10 TRAY SMARTBAKE FAULT ANALYSIS CHART

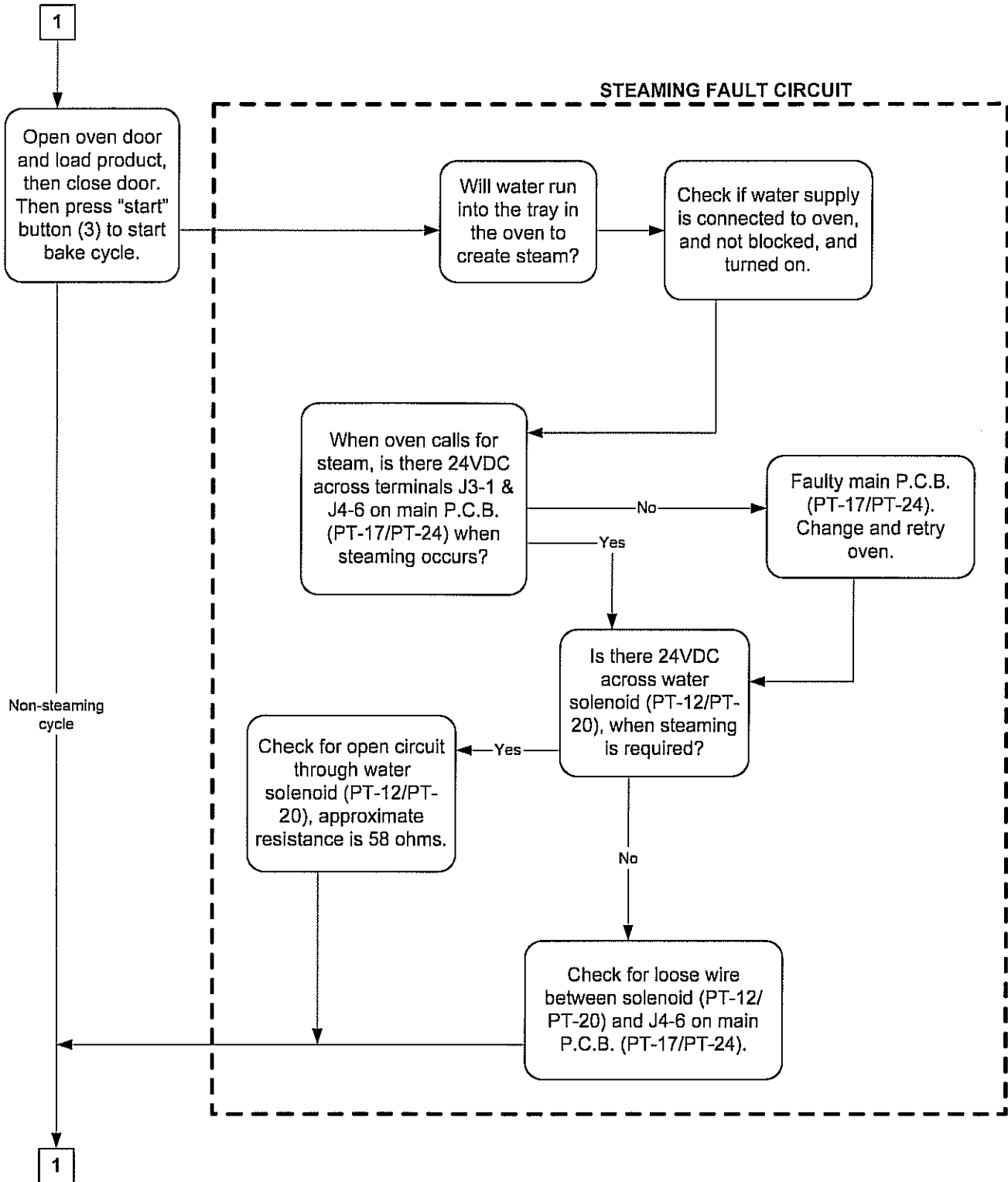

\*Note: Part (PT) numbers are indicated in parentheses; 4-tray oven PT numbers are listed first, then 10-tray oven PT numbers unless otherwise indicated.

## 4 TRAY & 10 TRAY SMARTBAKE FAULT ANALYSIS CHART

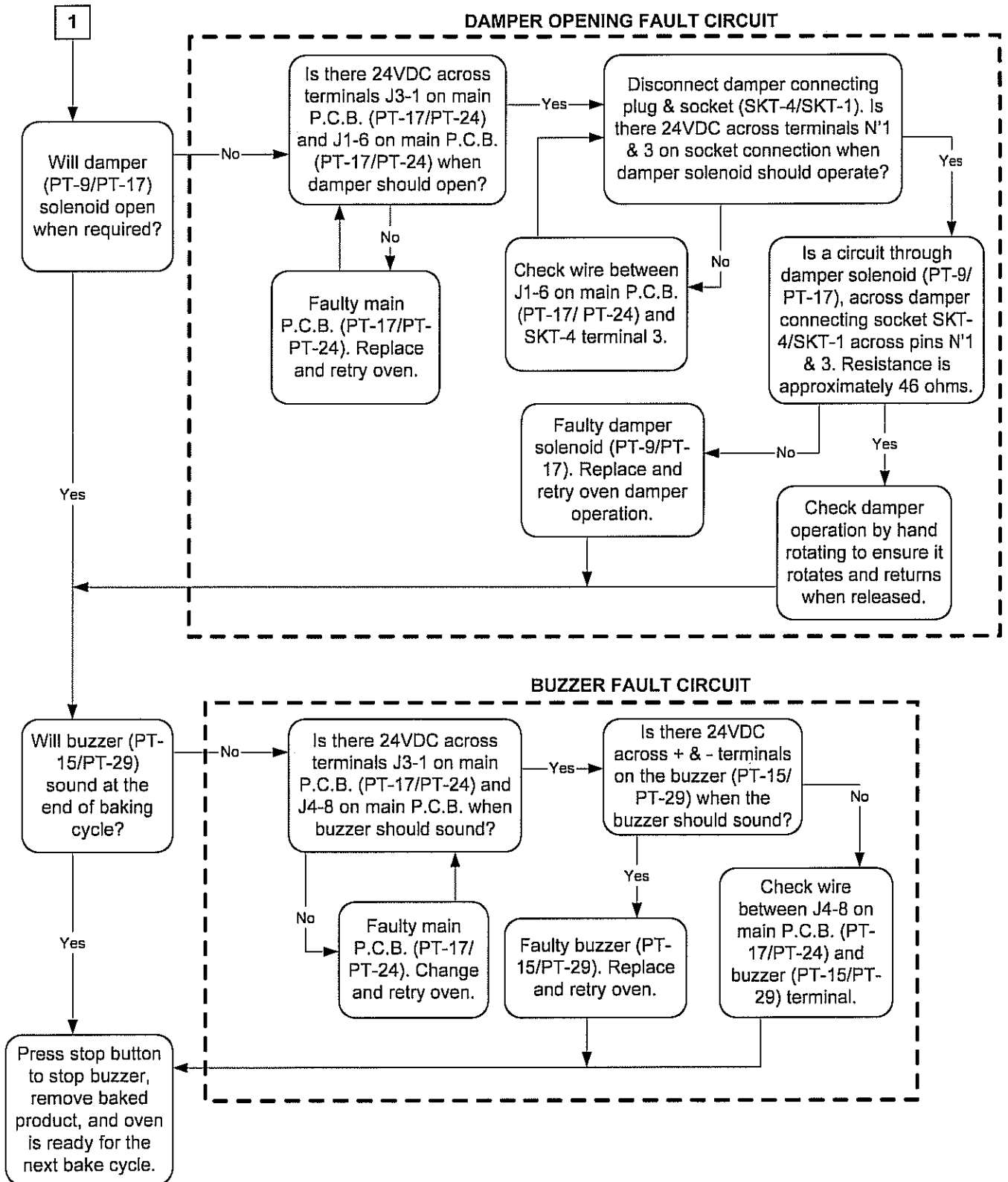

\*Note: Part (PT) numbers are indicated in parentheses; 4-tray oven PT numbers are listed first, then 10-tray oven PT numbers unless otherwise indicated.

## 4 TRAY & 10 TRAY SMARTBAKE FAULT ANALYSIS CHART

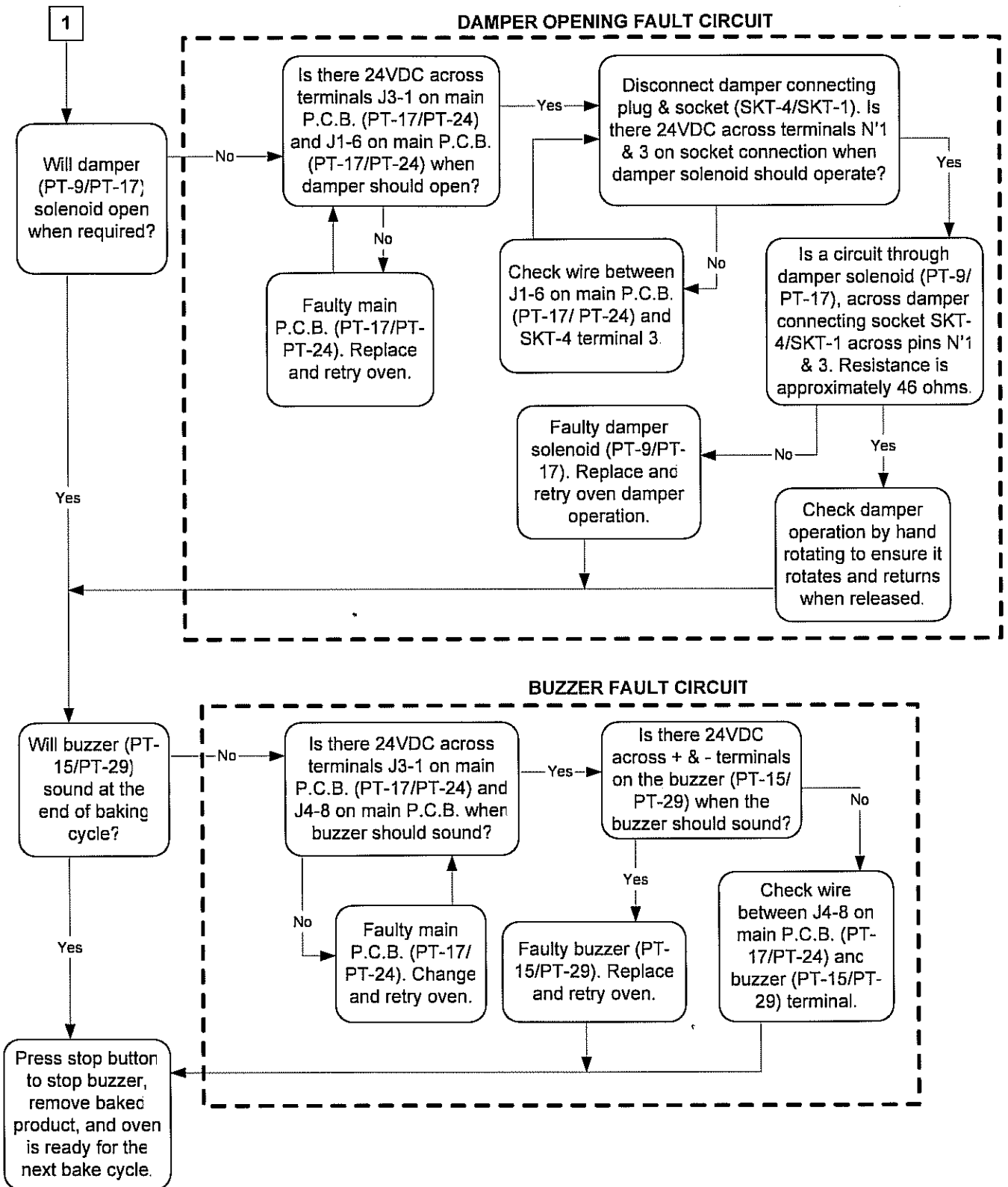

\*Note: Part (PT) numbers are indicated in parentheses; 4-tray oven PT numbers are listed first, then 10-tray oven PT numbers unless otherwise indicated

This section contains diagrams detailing the electrical components of the 4-tray and 10-tray BXC convection ovens.

**4-tray BXC Oven** (starts on page 34)

- Electrical Components, M189E25-01000
- PCB Connections, M158E25-21000
- PCB Outputs, M189E25-01100
- Power Circuit Diagram, M189E25-00100
- Control Circuit & 24V DC Power Supply, M189E25-00400
- Fan Motor Connections & Heating Element Wiring, M189E25-00500

**10-tray BXC Oven** (starts on page 40)

- Electrical Components, M150E25-55000
- Main Control Panel Layout, M150E25-20200
- PCB Connections, M150E25-51400
- PCB Outputs, M150E25-20400
- Interior Light & Power Supply Circuit, M150E25-20500
- Motor Power Circuit Diagram, M150E25-20600
- Heating Power Circuit Diagram, M150E25-20700
- Fan Motor Connections & Heating Element Wiring, M150E25-20300

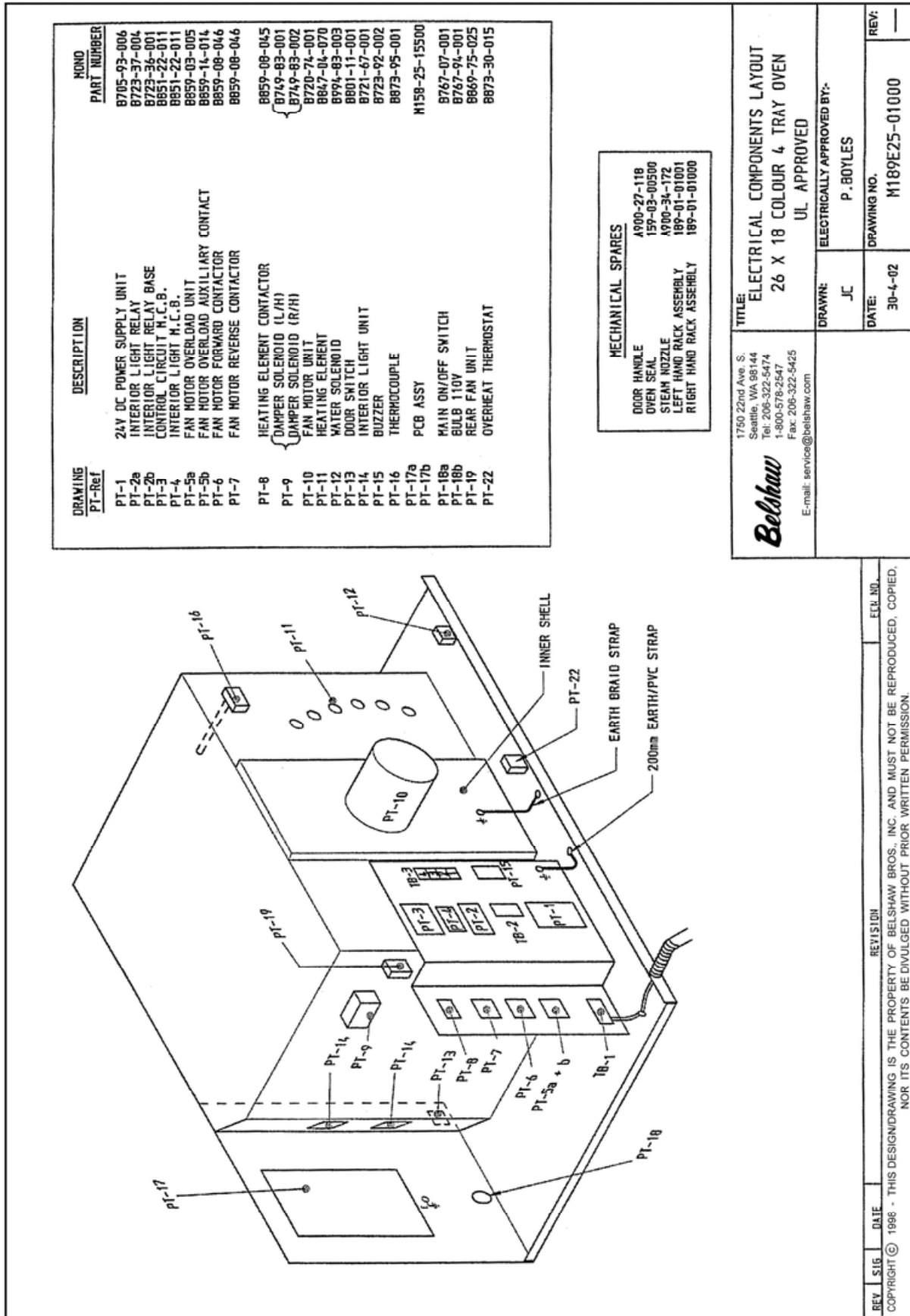

DRAWING PT-Ref.	DESCRIPTION	MONO PART NUMBER
PT-1	24V DC POWER SUPPLY UNIT	B705-93-006
PT-2a	INTERIOR LIGHT RELAY	B723-37-004
PT-2b	INTERIOR LIGHT RELAY BASE	B723-36-001
PT-3	CONTROL CIRCUIT M.C.B.	B651-22-011
PT-4	INTERIOR LIGHT M.C.B.	B651-22-011
PT-5a	FAN MOTOR OVERLOAD UNIT	B859-03-005
PT-5b	FAN MOTOR OVERLOAD AUXILIARY CONTACT	B859-11-014
PT-6	FAN MOTOR FORWARD CONTACTOR	B859-08-046
PT-7	FAN MOTOR REVERSE CONTACTOR	B859-08-046
PT-8	HEATING ELEMENT CONTACTOR	B859-08-045
PT-9	DAMPER SOLENOID (L/H)	B749-83-001
PT-10	DAMPER SOLENOID (R/H)	B749-83-002
PT-11	FAN MOTOR UNIT	B720-74-001
PT-12	HEATING ELEMENT	B647-04-070
PT-13	WATER SOLENOID	B994-83-003
PT-14	DOOR SWITCH	B601-11-001
PT-15	INTERIOR LIGHT UNIT	B721-67-001
PT-16	BUZZER	B723-92-002
PT-17a	THERMOCOUPLE	B873-95-001
PT-17b	PCB ASSY	M158-25-15500
PT-18a	MAIN ON/OFF SWITCH	B767-07-001
PT-18b	BULB 110V	B767-94-001
PT-19	REAR FAN UNIT	B669-75-025
PT-22	OVERHEAT THERMOSTAT	B673-30-015

MECHANICAL SPARES	
DOOR HANDLE	A900-27-118
OVEN SEAL	159-03-00500
STEAM NOZZLE	1900-34-172
LEFT HAND RACK ASSEMBLY	189-01-01001
RIGHT HAND RACK ASSEMBLY	189-01-01000

**Belshaw**  
1750 22nd Ave. S.  
Seattle, WA 98144  
Tel: 206-322-5474  
1-800-576-2547  
Fax: 206-322-5425  
E-mail: service@belshaw.com

**TITLE:**  
ELECTRICAL COMPONENTS LAYOUT  
26 X 18 COLOUR 4 TRAY OVEN  
UL APPROVED

**DRAWN:** JC  
**ELECTRICALLY APPROVED BY:** P. BOYLES

**DATE:** 30-4-02  
**DRAWING NO.:** M189E25-01000

**REV:** —

REV	DATE	REVISION	ECL. NO.
1			

COPYRIGHT © 1986 - THIS DESIGN/DRAWING IS THE PROPERTY OF BELSHAW BROS., INC. AND MUST NOT BE REPRODUCED, COPIED, NOR ITS CONTENTS BE DIVULGED WITHOUT PRIOR WRITTEN PERMISSION.



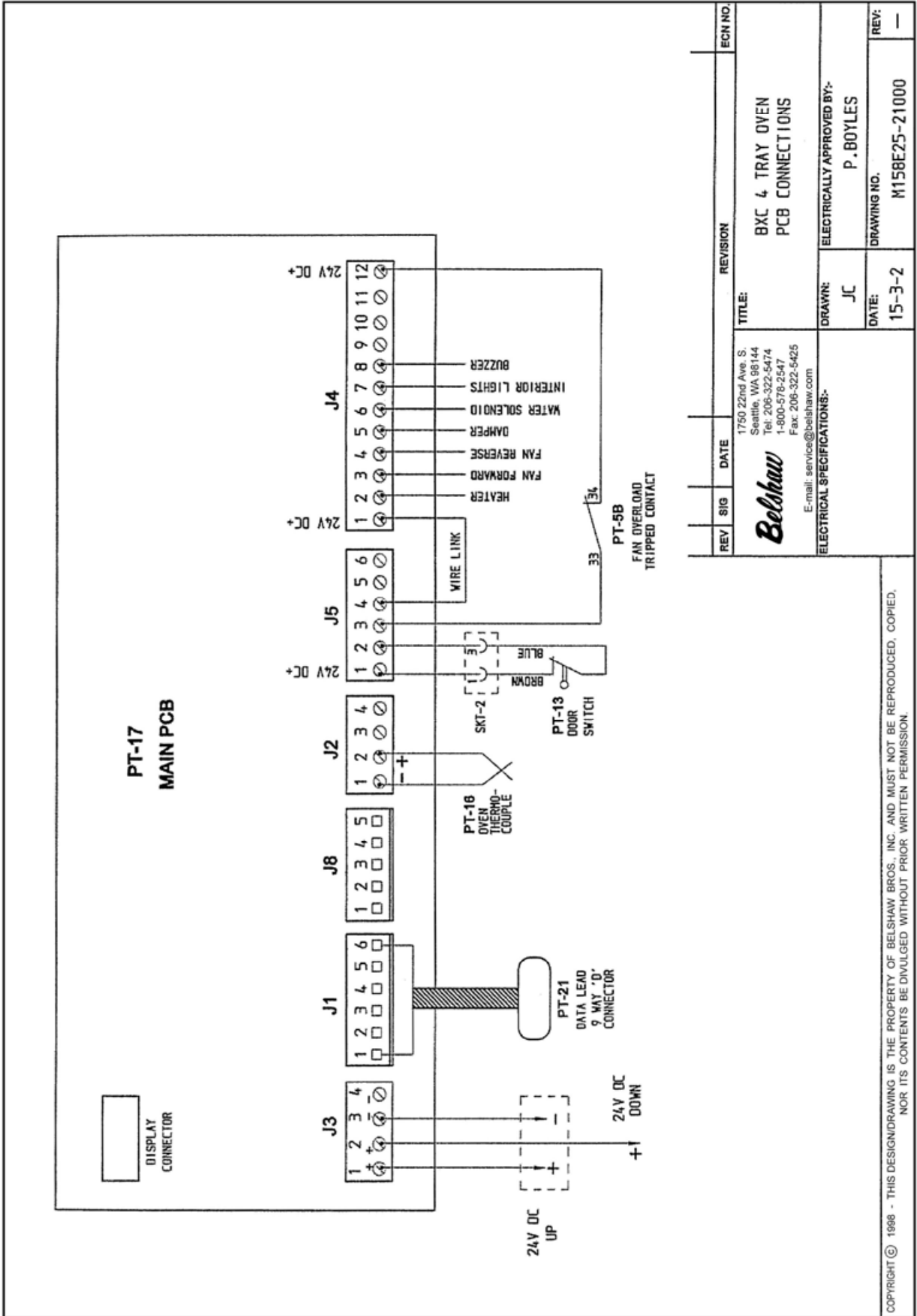

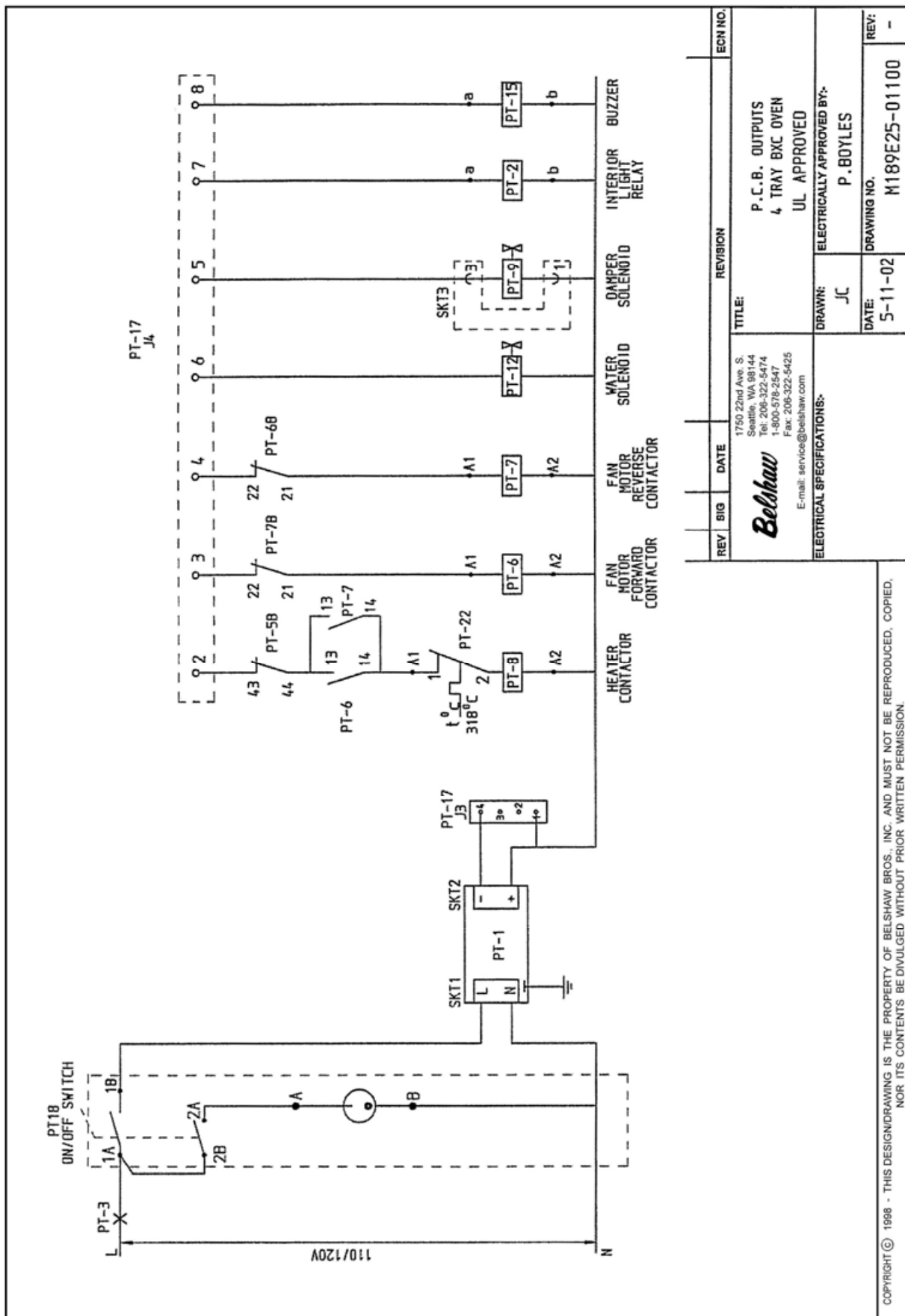

REV	SIG	DATE	REVISION	ECN NO.
<p>1750 22nd Ave. S. Seattle, WA 98144 Tel: 206-322-5474 1-800-576-2547 Fax: 206-322-5425 E-mail: service@belshaw.com</p>				
<p><b>Belshaw</b></p>			<p>TITLE: P.C.B. OUTPUTS 4 TRAY BXC OVEN UL APPROVED</p>	
<p>ELECTRICAL SPECIFICATIONS:</p>			<p>DRAWN: JC</p>	
<p>DATE: 5-11-02</p>			<p>ELECTRICALLY APPROVED BY: P. BOYLES</p>	
<p>DRAWING NO. M189E25-01100</p>			<p>REV: -</p>	

COPYRIGHT © 1998 - THIS DESIGN/DRAWING IS THE PROPERTY OF BELSHAW BROS., INC. AND MUST NOT BE REPRODUCED, COPIED, NOR ITS CONTENTS BE DIVULGED WITHOUT PRIOR WRITTEN PERMISSION.

IF IN ANY DOUBT - ASK

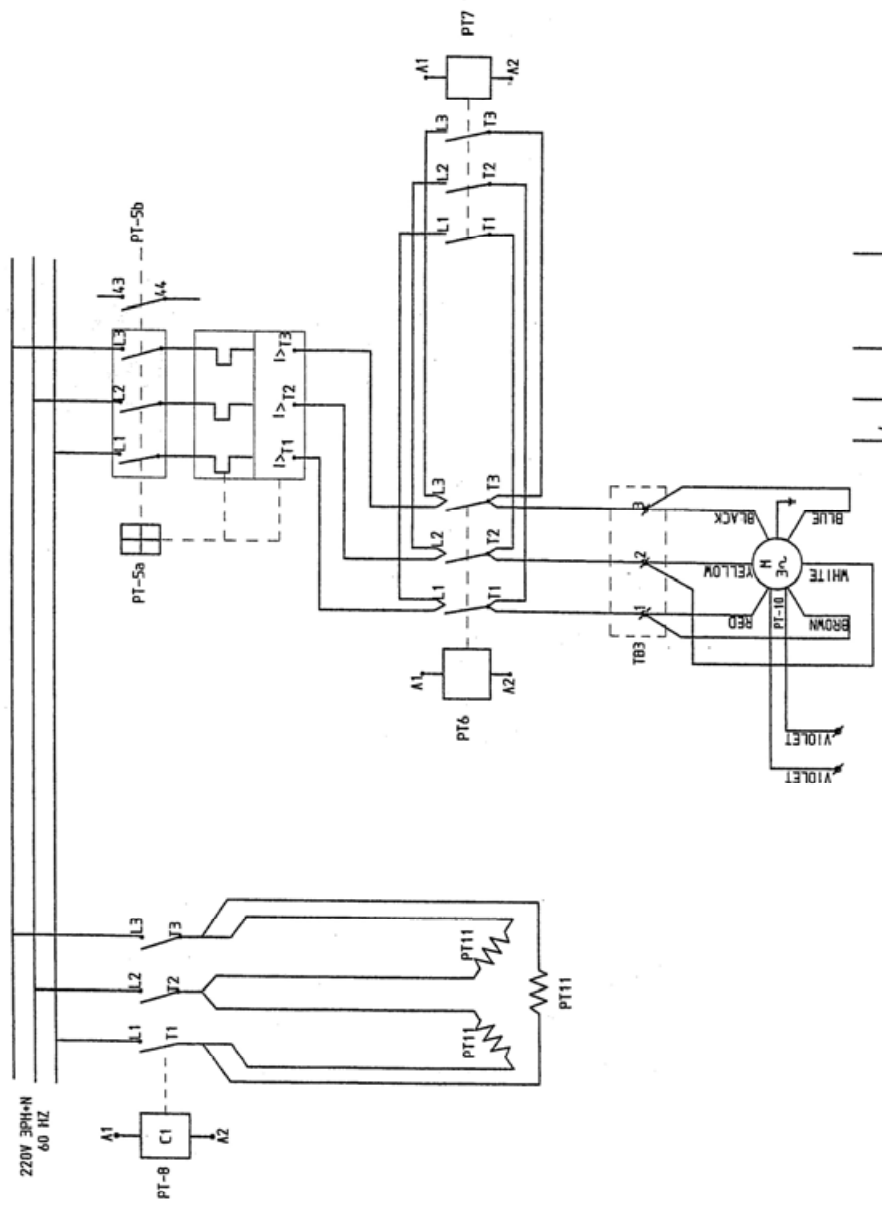

REV	SIG	DATE	REVISION	ECN NO.
<b>Belshaw</b> 1750 22nd Ave. S. Seattle, WA 98144 Tel: 206-322-5474 1-800-578-2547 Fax: 206-322-5425 E-mail: service@belshaw.com				
ELECTRICAL SPECIFICATIONS:-			TITLE:	
220V 3PH + N 60HZ			POWER CIRCUIT DIAGRAM	
			4 TRAY OVEN	
			UL APPROVED	
			ELECTRICALLY APPROVED BY:-	
			P. BOYLES	
			DRAWING NO.	
			M189E25-00100	
			REV:	
			-	

COPYRIGHT © 1998 - THIS DESIGN/DRAWING IS THE PROPERTY OF BELSHAW BROS., INC. AND MUST NOT BE REPRODUCED, COPIED, NOR ITS CONTENTS BE DIVULGED WITHOUT PRIOR WRITTEN PERMISSION.

IF IN ANY DOUBT - ASK

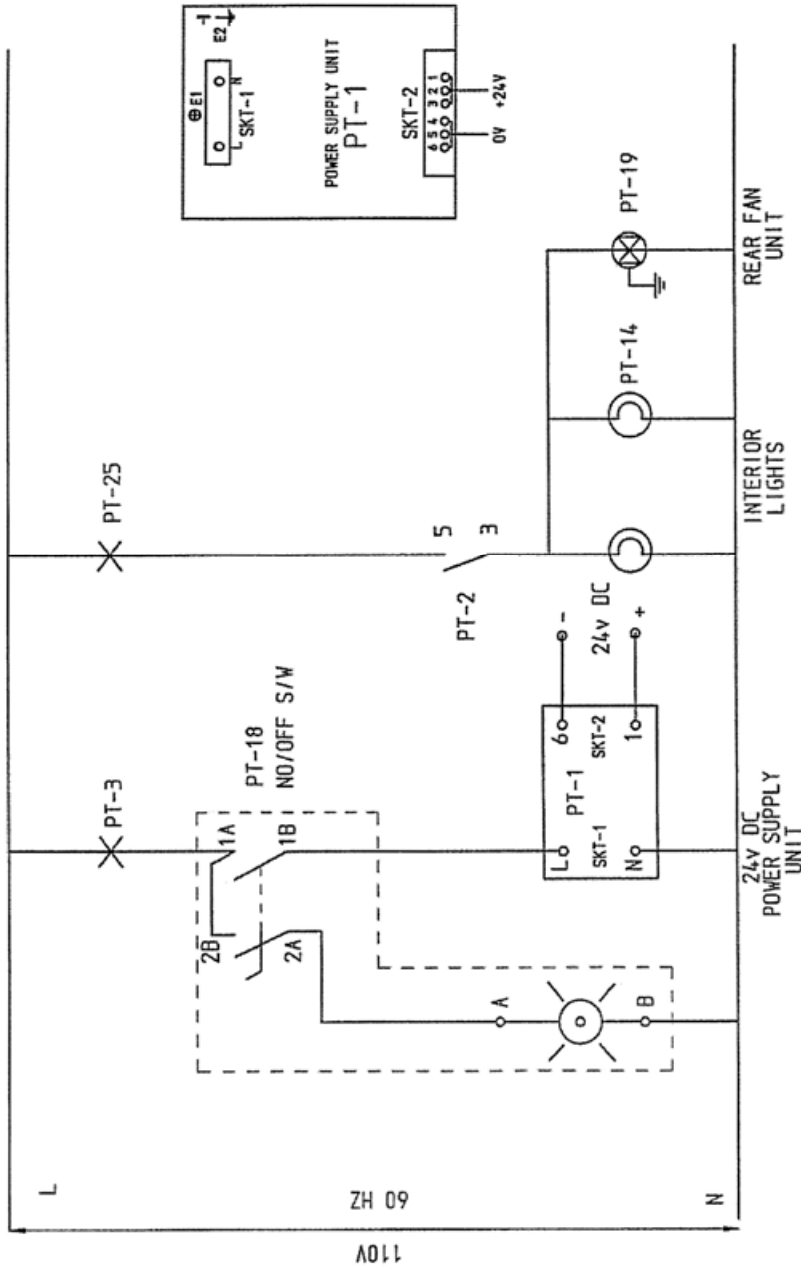

REV	SIG	DATE	REVISION	ECN NO.
<p>1750 22nd Ave. S. Seattle, WA 98144 Tel: 206-322-5474 1-800-578-2547 Fax: 206-322-5425 E-mail: service@belshaw.com</p>				
<p><b>Belshaw</b></p>			<p>TITLE: CONTROL CIRCUIT &amp; 24V DC POWER SUPPLY UL APPROVED</p>	
ELECTRICAL SPECIFICATIONS:				
DRAWN: JC			ELECTRICALLY APPROVED BY: P. BOYLES	
DATE: 2-5-02			DRAWING NO. M189E25-004.00	
			REV: —	

COPYRIGHT © 1998 - THIS DESIGN/DRAWING IS THE PROPERTY OF BELSHAW BROS., INC. AND MUST NOT BE REPRODUCED, COPIED, NOR ITS CONTENTS BE DIVULGED WITHOUT PRIOR WRITTEN PERMISSION.

HEATING ELEMENT WIRING

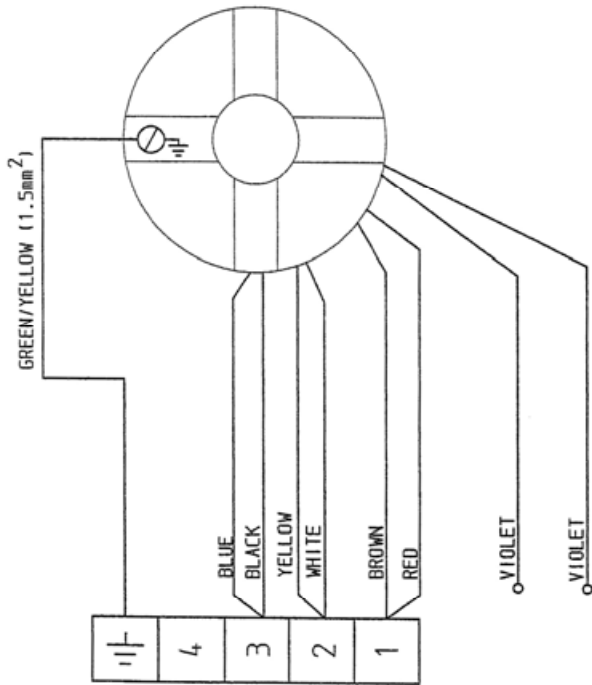

FAN MOTOR CONNECTIONS

PT11

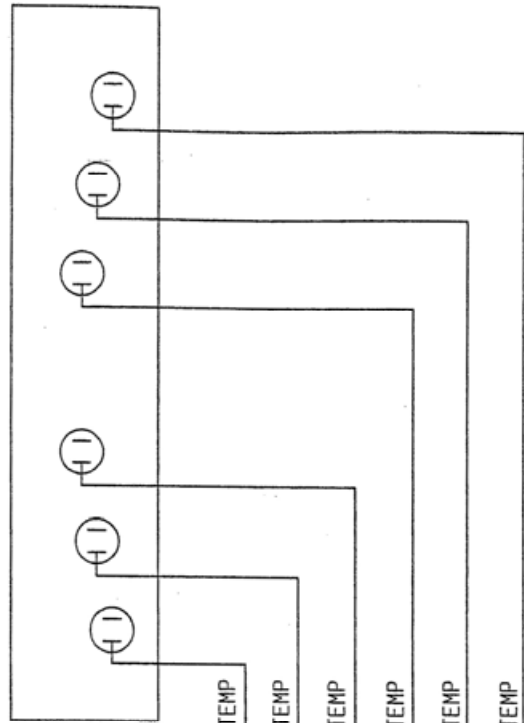

- L1 1.5 mm<sup>2</sup> PTEMP
- L1 1.5 mm<sup>2</sup> PTEMP
- L2 1.5 mm<sup>2</sup> PTEMP
- L3 1.5 mm<sup>2</sup> PTEMP
- L3 1.5 mm<sup>2</sup> PTEMP
- L2 1.5 mm<sup>2</sup> PTEMP

REV	SIG	DATE	REVISION	ECH NO.
			FAN MOTOR CONNECTIONS & HEATING ELEMENT WIRING UL APPROVED	
<b>Belshaw</b> 1750 22nd Ave. S. Seattle, WA 98144 Tel: 206-322-5474 1-800-578-2547 Fax: 206-322-5425 E-mail: service@belshaw.com			TITLE: FAN MOTOR CONNECTIONS & HEATING ELEMENT WIRING UL APPROVED	
ELECTRICAL SPECIFICATIONS:-			ELECTRICALLY APPROVED BY:-	
220V 3PH+N 60HZ			P. BOYLES	
			DRAWING NO. M189E25-00500	
			REV: -	

COPYRIGHT © 1988 - THIS DESIGN/DRAWING IS THE PROPERTY OF BELSHAW BROS., INC. AND MUST NOT BE REPRODUCED, COPIED, NOR ITS CONTENTS BE DIVULGED WITHOUT PRIOR WRITTEN PERMISSION.

DRAWING		DESCRIPTION	PART NUMBER
PT-Ref			
PT-1		INTERIOR LIGHT M.C.B.	8851-22-011
PT-2		CONTROL CIRCUIT M.C.B.	8851-22-011
PT-4a		FAN MOTOR OVERLOAD UNIT N'1 (TOP)	8859-03-005
PT-4b		FAN MOTOR OVERLOAD N'1 AUXILIARY CONTACT	8859-14-011
PT-5a		FAN MOTOR OVERLOAD UNIT N'2 (BOTTOM)	8859-03-005
PT-5b		FAN MOTOR OVERLOAD N'2 AUXILIARY CONTACT	8859-14-014
PT-8a		INTERIOR LIGHT RELAY	8723-37-004
PT-8b		INTERIOR LIGHT RELAY BASE	8723-36-001
PT-10a		FAN MOTOR CONTACTOR N'1-FORWARD (TOP MOTOR)	8859-08-046
PT-10b		FAN MOTOR CONTACTOR N'1-REVERSE (TOP MOTOR)	8859-08-046
PT-10c		FAN MOTOR N'1-ELECT/MECH INTERLOCK	8859-18-004
PT-11a		FAN MOTOR CONTACTOR N'2-FORWARD (BTM MOTOR)	8859-08-046
PT-11b		FAN MOTOR CONTACTOR N'2-REVERSE (BTM MOTOR)	8859-08-046
PT-11c		FAN MOTOR N'2-ELECT/MECH INTERLOCK	8859-18-004
PT-14		24V DC POWER SUPPLY UNIT	8705-93-006
PT-15		TOP HEATING ELEMENT CONTACTOR	8801-08-023
PT-16		BOTTOM HEATING ELEMENT CONTACTOR	8801-08-023
PT-17		{ DAMPER SOLENOID (L/H) DAMPER SOLENOID (R/H)	{ 8749-83-001 8749-83-002
PT-18		FAN MOTOR UNIT N'1 (TOP MOTOR)	8720-74-001
PT-19		FAN MOTOR UNIT N'1 (BOTTOM MOTOR)	8720-74-001
PT-20		WATER SOLENOID	8994-83-003
PT-21		OVERHEAT THERMOSTAT N'1	8873-30-014
PT-23		OVEN THERMOCOUPLE	8873-95-001
PT-24a		PCB ASSY	M158-25-15500
PT-24b			
PT-26a		MAIN OFF/ON SWITCH	8761-07-001
PT-26b		110V BULB	8761-92-001
PT-27		DOOR SWITCH	8827-11-001
PT-28		INTERIOR LIGHT UNIT	8721-67-001
PT-29		BUZZER	8982-92-002
PT-30		HEATING ELEMENT UNIT N'1 (TOP)	8847-04-073
PT-31		HEATING ELEMENT UNIT N'2 (BOTTOM)	8847-04-073
PT-32		DATA LINK SOCKET CABLE	8705-25-005
PT-34		REAR FAN UNIT	8869-75-025

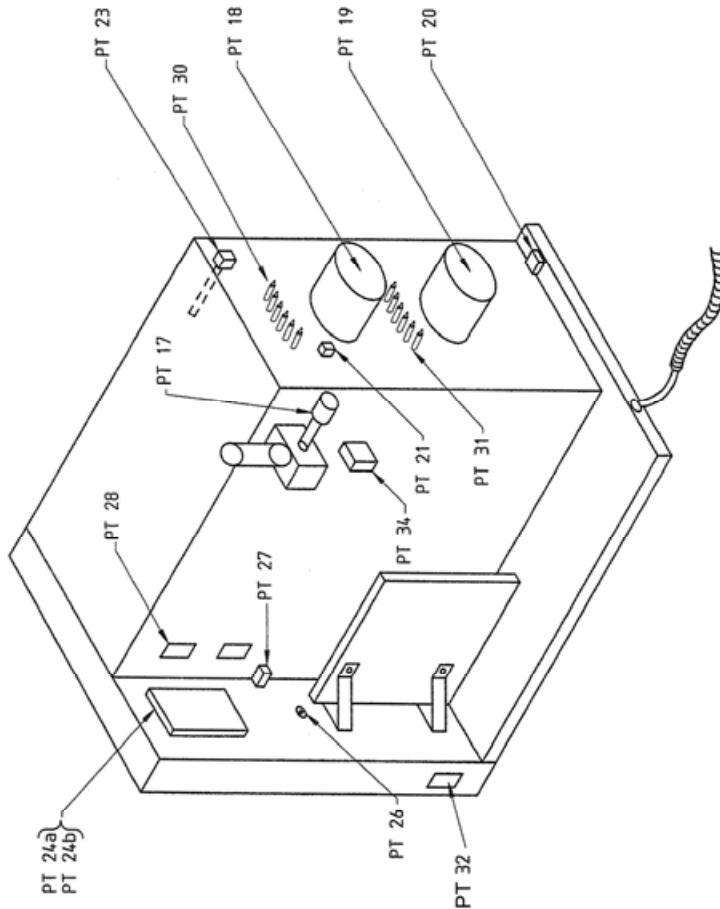

REV	SIG	DATE	REVISION	ECN NO.
<b>Belshaw</b> 1750 22nd Ave. S. Seattle, WA 98144 Tel: 206-322-5474 1-800-578-2547 Fax: 206-322-5425 E-mail: service@belshaw.com				
TITLE: ELECTRICAL COMPONENTS LAYOUT BXC COLOUR 10 TRAY (UL APPROVED)			DRAWN: JC ELECTRICALLY APPROVED BY: P. BOYLES	
ELECTRICAL SPECIFICATIONS:-			DRAWING NO. M150E25-55000	
DATE: 8/7/02			REV: —	

COPYRIGHT © 1998 - THIS DESIGN/DRAWING IS THE PROPERTY OF BELSHAW BROS., INC. AND MUST NOT BE REPRODUCED, COPIED, NOR ITS CONTENTS BE DIVULGED WITHOUT PRIOR WRITTEN PERMISSION.

IF IN ANY DOUBT - ASK

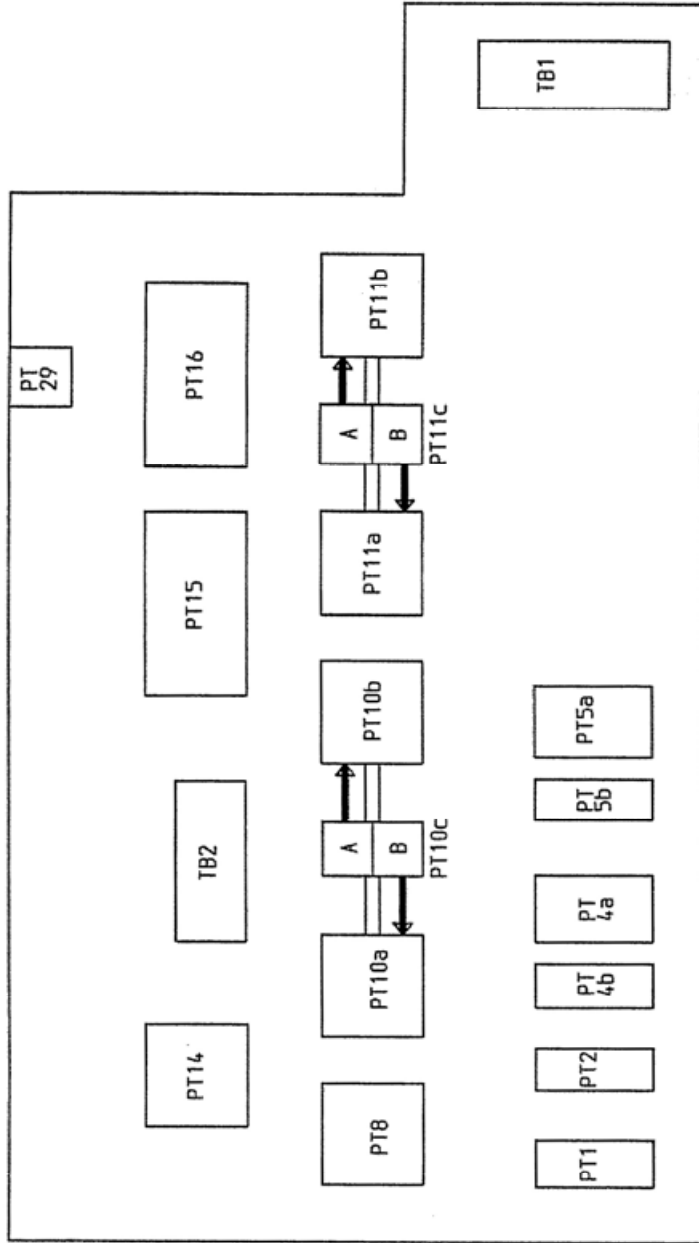

REV	SIG	DATE	REVISION	ECN NO.
<p>1750 22nd Ave. S. Seattle, WA 98144 Tel: 206-322-5474 1-800-578-2547 Fax: 206-322-5425 E-mail: service@belshaw.com</p>				
<p><b>Belshaw</b></p>				
<p><b>ELECTRICAL SPECIFICATIONS:</b></p>				
<p>TITLE: MAIN CONTROL PANEL LAYOUT 10 TRAY OVEN (UL APPROVED)</p>			<p>DRAWN: JC</p>	
<p>DRAWN: ELECTRICALLY APPROVED BY:- P. BOYLES</p>			<p>DATE: 26/6/02</p>	
<p>REVISION</p>			<p>DRAWING NO. M150E25-20200</p>	
<p>REV: -</p>			<p>REV: -</p>	

COPYRIGHT © 1988 - THIS DESIGN/DRAWING IS THE PROPERTY OF BELSHAW BROS., INC. AND MUST NOT BE REPRODUCED, COPIED, NOR ITS CONTENTS BE DIVULGED WITHOUT PRIOR WRITTEN PERMISSION.

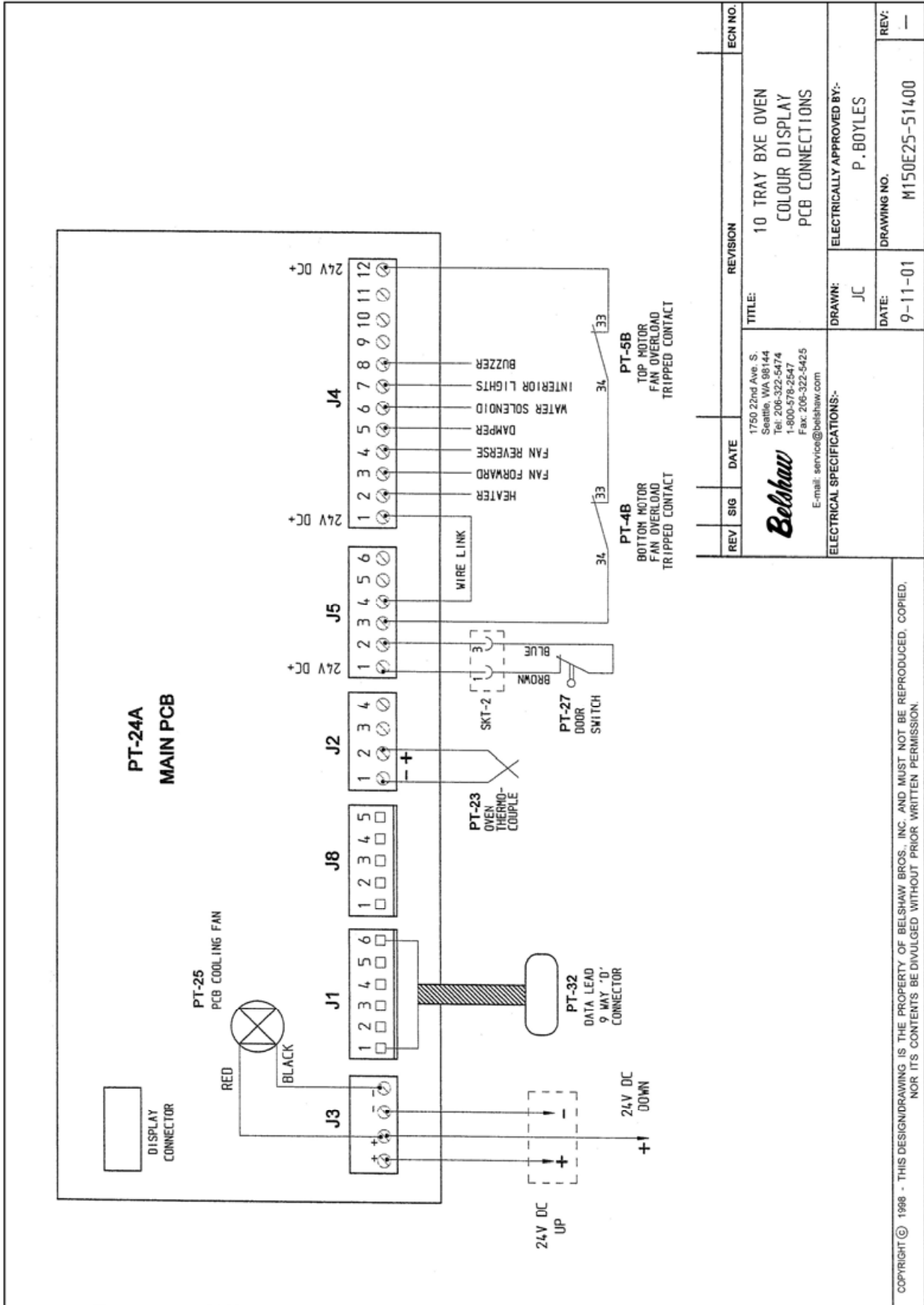

COPYRIGHT © 1998 - THIS DESIGN/DRAWING IS THE PROPERTY OF BELSHAW BROS., INC. AND MUST NOT BE REPRODUCED, COPIED, NOR ITS CONTENTS BE DIVULGED WITHOUT PRIOR WRITTEN PERMISSION.



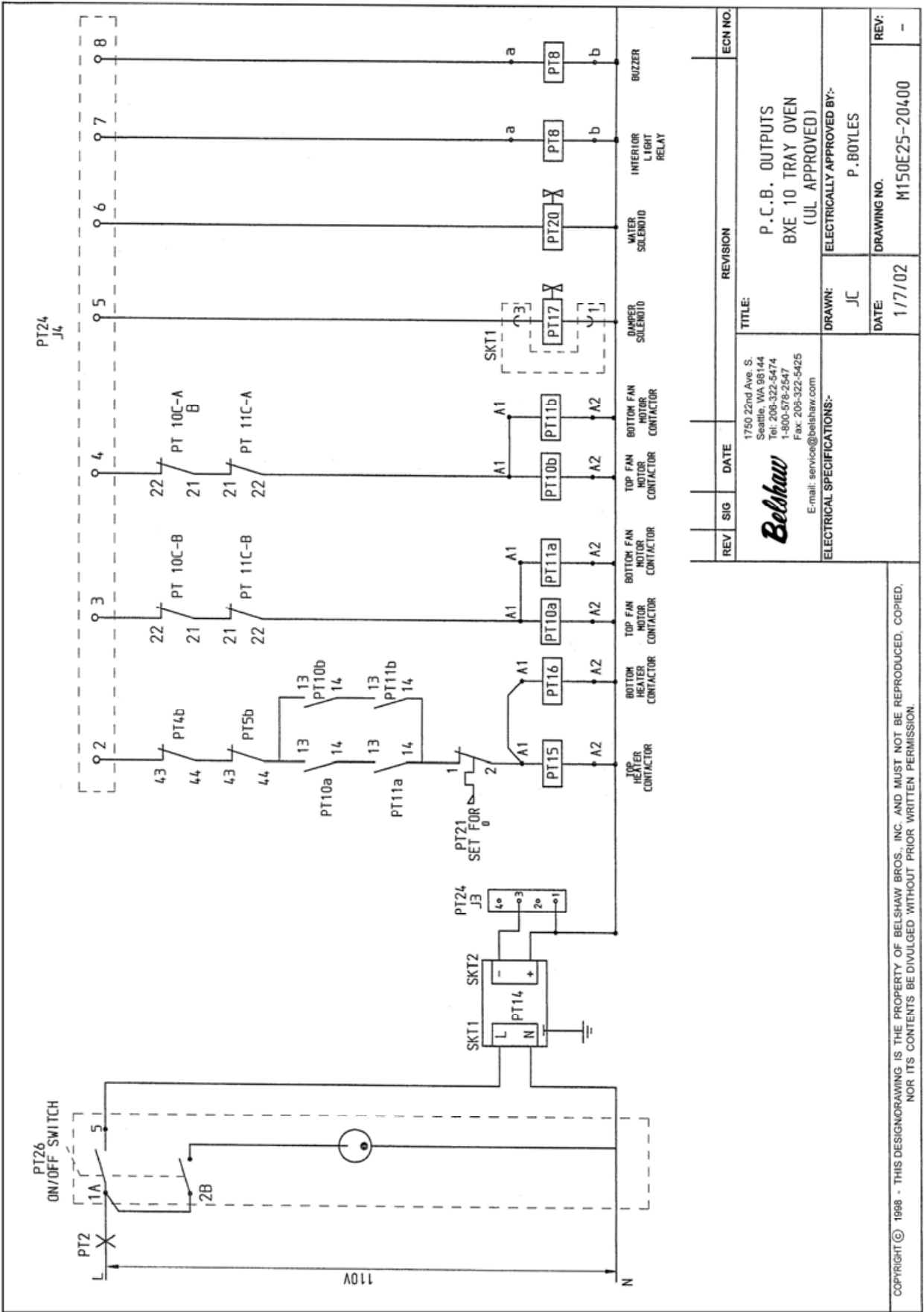

COPYRIGHT © 1988 - THIS DESIGN DRAWING IS THE PROPERTY OF BELSHAW BROS., INC. AND MUST NOT BE REPRODUCED, COPIED, OR ITS CONTENTS BE DIVULGED WITHOUT PRIOR WRITTEN PERMISSION.

REV	SIG	DATE	REVISION	ECN NO.
<b>Belshaw</b> 1750 22nd Ave. S. Seattle, WA 98144 Tel: 206-322-5474 1-800-578-2647 Fax: 206-322-5425 E-mail: service@belshaw.com			<b>TITLE:</b> P.C.B. OUTPUTS BXE 10 TRAY OVEN (UL APPROVED)	
<b>ELECTRICAL SPECIFICATIONS:-</b> DRAWN: JC DATE: 1/7/02			<b>ELECTRICALLY APPROVED BY:-</b> P. BOYLES	
			<b>DRAWING NO.</b> M150E25-20400	<b>REV:</b> -

IF IN ANY DOUBT - ASK

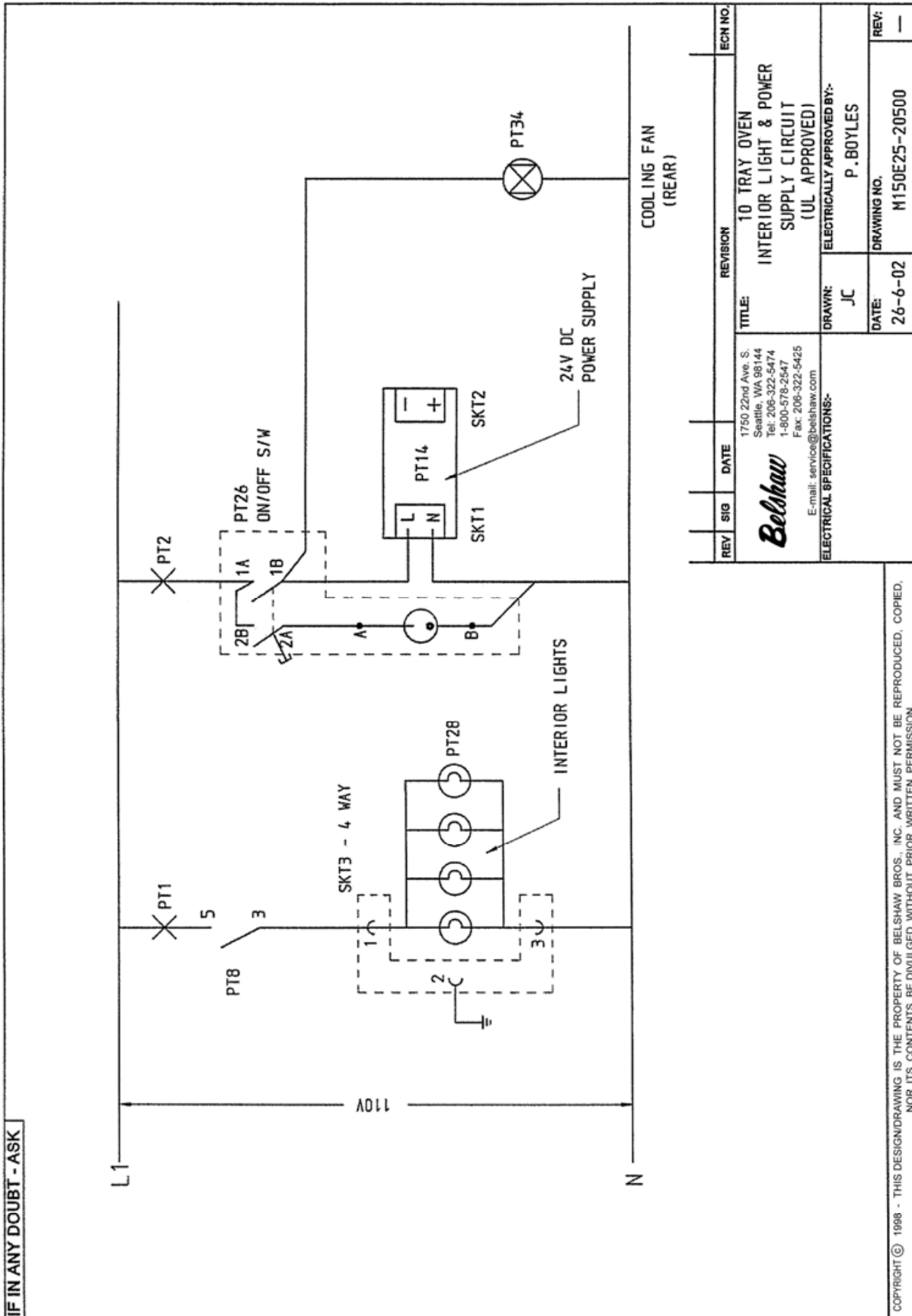

REV	SIG	DATE	REVISION	ECH NO.
			10 TRAY OVEN INTERIOR LIGHT & POWER SUPPLY CIRCUIT (UL APPROVED)	
<b>Belshaw</b> 1750 22nd Ave. S. Seattle, WA 98144 Tel: 206-322-5474 1-800-578-2547 Fax: 206-322-5425 E-mail: service@belshaw.com			DRAWN: JC DATE: 26-6-02 DRAWING NO. M150E25-20500	
ELECTRICAL SPECIFICATIONS:-			ELECTRICALLY APPROVED BY:- P. BOYLES	
COPYRIGHT © 1998 - THIS DESIGN/DRAWING IS THE PROPERTY OF BELSHAW BROS., INC. AND MUST NOT BE REPRODUCED, COPIED, NOR ITS CONTENTS BE DIVULGED WITHOUT PRIOR WRITTEN PERMISSION.			REV: -	

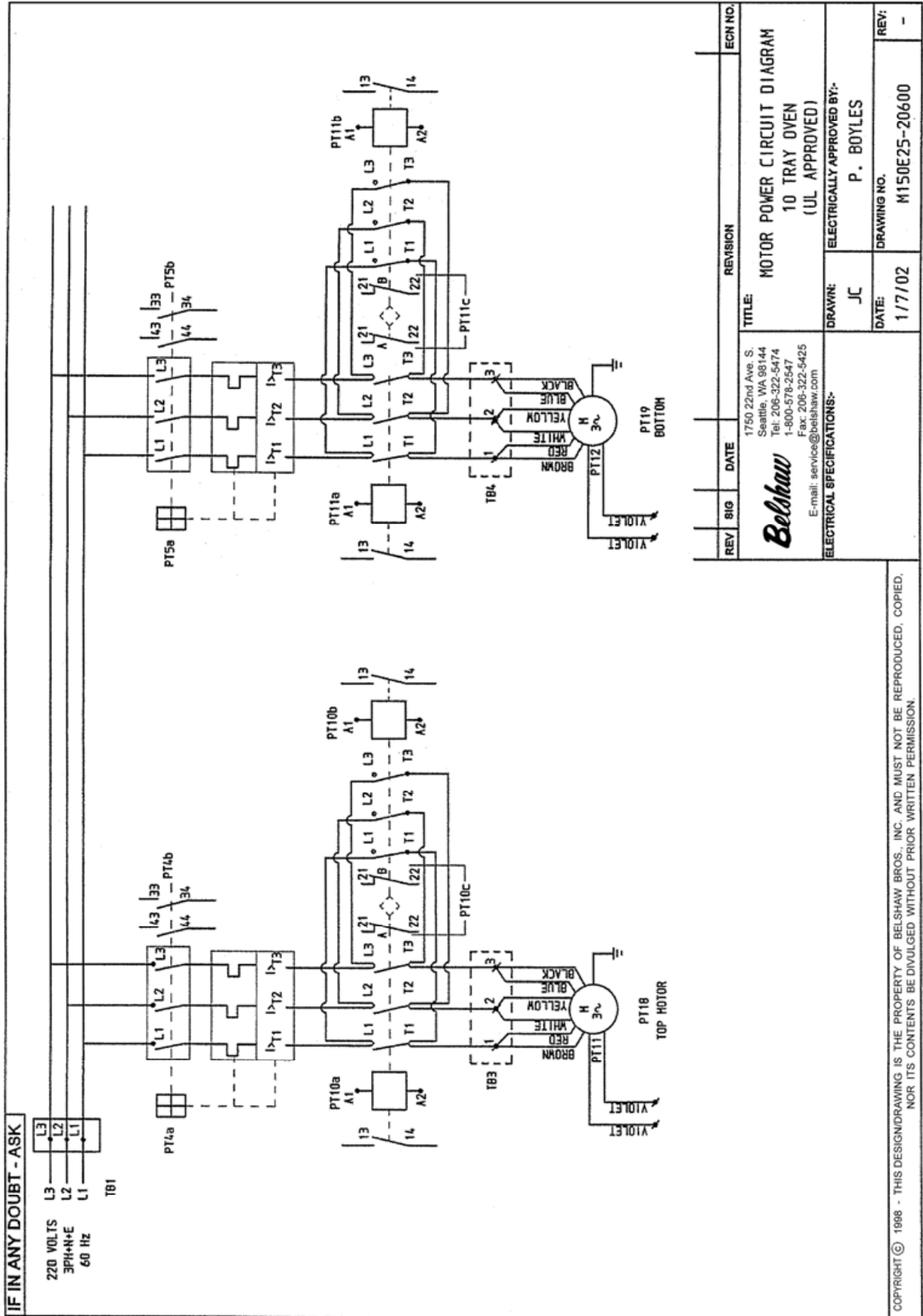

REV	SIG	DATE	REVISION	EGN NO.
<p>1750 22nd Ave. S. Seattle, WA 98144 Tel: 206-322-5474 1-800-578-2547 Fax: 206-322-5425 E-mail: service@belshaw.com</p>				
<p><b>Belshaw</b></p>			<p>TITLE: MOTOR POWER CIRCUIT DIAGRAM 10 TRAY OVEN (UL APPROVED)</p>	
<p>ELECTRICAL SPECIFICATIONS:-</p>			<p>DRAWN: JC DATE: 1/7/02 DRAWING NO. M150E25-20600</p>	
<p>ELECTRICALLY APPROVED BY:-</p>			<p>P. BOYLES</p>	
<p>REV: -</p>			<p>REV: -</p>	

