

Service Manual for

SNAPPER[®]

Models LE317 & LE319 Single Stage SNOW THROWERS

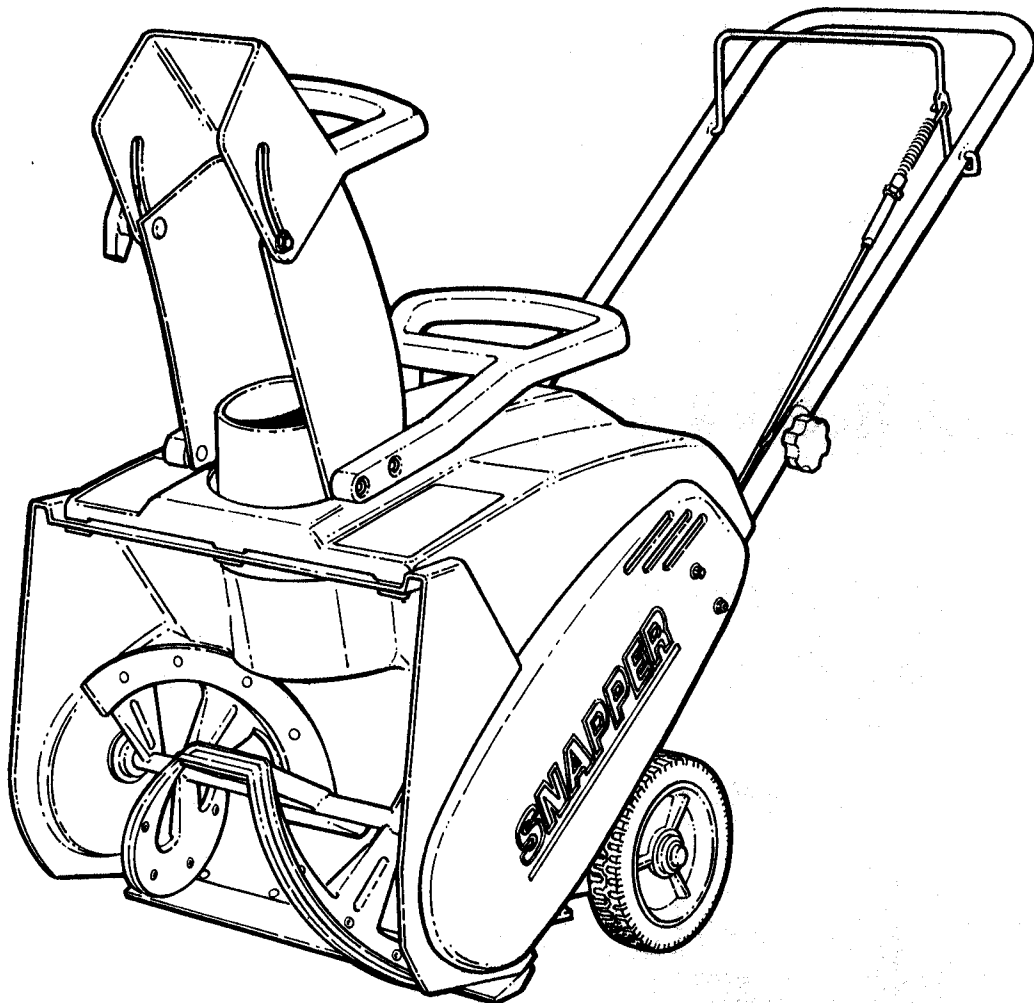

SNAPPER®McDonough, GA., 30253 U.S.A.

(I.R. 11/94) MANUAL #07015

IMPORTANT SAFETY INSTRUCTIONS

WARNING: Failure to comply with the following instructions may result in serious injury to the operator or other persons. The owner of the snow thrower must understand these instructions and, furthermore, must allow only persons who understand these instructions to operate snow thrower. Each person operating the snow thrower must be of sound mind and body and must not be under the influence of any substance which might impair vision, dexterity, or judgement. If you have any questions pertaining to your snow thrower which your dealer cannot answer to your satisfaction, call or write the Customer Service Department at SNAPPER, McDonough, Georgia 30253. Phone: (404) 954-2500.

PROTECTION FOR CHILDREN

1. **DO NOT** allow children in the area when snow thrower is being operated.
2. **DO NOT** allow pre-teenage children to operate snow thrower.
3. **DO NOT** allow irresponsible teenagers to operate the machine - allow teenagers only if exhibiting mature judgement and then only after being thoroughly instructed and under the close supervision of an experienced operator.

PREPARATION

1. Read this manual, get to know where all controls are located and practice how to use them before starting for the first time, and at the beginning of each season. Pay attention to Warning and Instructional Decals on engine and snow thrower.
2. Wear adequate winter clothing including boots which will give you maximum footing on slippery surfaces. Exercise CAUTION to avoid slipping or falling.
3. Before the first snow fall, check the area to be cleared and remove all objects such as doormats, sticks, toys, wires, rocks, etc., which could be hurtled or jam the snow thrower.
4. Survey the area to be cleared beforehand and plan where snow is to be blown. Be prepared to release auger/impeller clutch or to change discharge chute direction quickly to discharge away from windows, cars, buildings and doorways to avoid property damage or personal injury from hurtled objects.
5. Handle fuel with care. Store only in an approved gasoline container. Move the machine outdoors where fumes can be safely dissipated before filling tank. Never add fuel to a running engine or hot engine. Replace gasoline cap securely & wipe up spilled fuel.

OPERATIONAL PRECAUTIONS

1. Before starting, make visual check to make sure auger/impeller housing is clear and all guards and shields are in place and tight.
2. Warn everyone in advance to stay clear of area but keep especially watchful for children and pets darting into area while operating.
3. Start engine only where exhaust fumes will be safely dissipated, allow a brief warm-up period, practice operation of controls outside before putting the machine to work.
4. Should the auger/impeller become clogged, release the auger/impeller clutch control and, as an additional precaution, stop the engine before attempting to unclog the auger/impeller or discharge chute.
5. After striking a foreign object, stop the engine (motor), remove the wire from spark plug, thoroughly inspect the snow thrower for any damage, and repair the damage before restarting and operating the snow thrower.
6. Stop the engine if the machine starts to vibrate excessively as this normally indicates mechanical problems. Disconnect the spark plug wire to prevent unintentional starting before servicing or repairing the machine.
7. **DO NOT** clear snow across the face of slopes. Exercise extreme caution when changing direction on slopes. **DO NOT** attempt to clear steep slopes.
8. Stop the engine and remove the key whenever you leave the unit unattended to eliminate the possibility of children or untrained adults from attempting to operate the machine.
9. Release clutch control and make sure auger/impeller has stopped before rotating discharge chute, adjusting deflector, or placing hands near auger/impeller.
10. **DO NOT** use snow thrower on surfaces above ground level, such as, a roof of a building.
11. Exercise extreme caution when operating on or crossing gravel drives, walks, or roads. Stay alert for hidden hazards or traffic.
12. **DO NOT** overload the machine capacity by attempting to clear snow at too fast a rate.
13. Never operate the machine at high transport speeds on slippery surfaces. Look behind and use care when backing.
14. Disengage power to the auger/impeller when snow thrower is transported or not in use.
15. Use only attachments and accessories approved by the manufacturer of the snow thrower (such as wheels weights, counterweights, cabs and the like).
16. Never operate the snow thrower without good visibility or light. Always be sure of your footing, and keep a firm hold on the handles. Walk; never run.

TABLE OF CONTENTS

Section I - INTRODUCTION	4
FAMILIARIZATION.....	4
NOMENCLATURE.....	4
Section II - MACHINE OPERATION	5-7
FUEL REQUIREMENTS.....	5
FUEL PRECAUTIONS.....	5
OPERATIONAL CONTROLS.....	5-6
PRE-START CHECKS.....	6
START/STOP PROCEDURE.....	6-7
OPERATION.....	7
Section III - SNOWTHROWING TECHNIQUES	8
Section IV - SERVICE	9-10
TOOLS REQUIRED.....	9
AUGER CLUTCH/BRAKE ADJUSTMENT.....	9
DRIVE BELT REPLACEMENT.....	10
ADJUSTMENTS (CARBURETOR - ENGINE SPEED).....	10
Section V - MAINTENANCE / STORAGE	11
LUBRICATION CHART.....	11
Section VI - TROUBLESHOOTING CHART	12-13
Section VII - OVERHAUL & REPAIR (AUGER HOUSING)	14-19
AUGER HOUSING COMPONENTS.....	14
CAUSES FOR REPAIR.....	14
AUGER HOUSING OVERHAUL.....	15-19
Section VIII - OVERHAUL & REPAIR (DRIVE SYSTEM)	20-22
DRIVE SYSTEM & CONTROLS.....	20
CAUSES FOR REPAIR (DRIVE SYSTEM).....	20-22
Section IX - ENGINE ACCESSORIES	23
INSTALLATION OF HIGH ALTITUDE JET.....	23
INSTALLATION OF ELECTRIC STARTER.....	23

Section I - INTRODUCTION

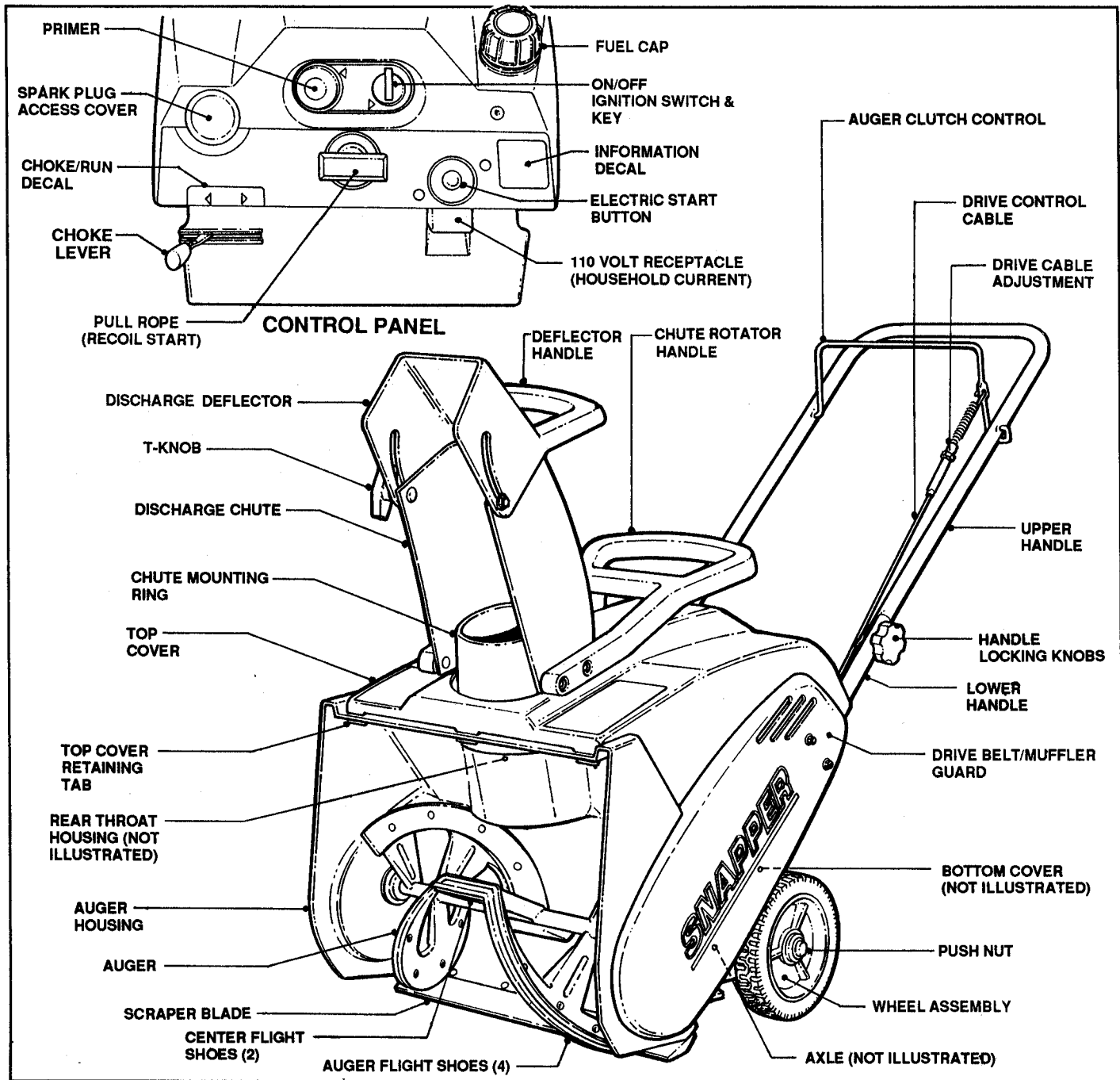

FIGURE 1.1

1.1 FAMILIARIZATION

This manual covers **SNAPPER Model LE317, LE319**, both **RECOIL** and **ELECTRIC START MODEL SNOW THROWERS**. The first number in the model designation indicates the horsepower of the engine, the next two numbers indicate the width in inches of the Auger Housing and the last number indicates the design series. Comprehensive engine overhaul/repair manuals and parts manuals for these models are available from your **SNAPPER** dealer at nominal cost. Refer to the Engine Owners Manual for specific details involving operation and service of the engine.

1.2 NOMENCLATURE

The nomenclature drawing above (Figure 1.1) shows the essential parts of the **SNAPPER Models LE317 & LE319 SNOW THROWERS**. Make sure that each person authorized to operate this Snow Thrower reads this manual prior to operation and pays particular attention to the Safety Precautions on the inside front cover and to the Warning Decals on the machine. Also, make sure all operators are thoroughly familiar with all controls and how to use them before operating the blower. Make certain that operators know beforehand how to stop the Auger and Engine in preparation for possible emergencies.

Section II - MACHINE OPERATION

2.1 The **SNAPPER LE317** or **LE319** is powered by a 3 Horsepower, 2 cycle engine and will clear a path either 17 inches or 19 inches wide and will throw snow from 3 to 20 feet away depending on the Discharge Deflector setting and snow conditions. Due to the light weight of these units, they are ideally suited for clearing decks and porches. These units have a fuel capacity of 1.25 quarts which will result in an operational time of 1 1/4 to 1 3/4 hours.

2.2 Save this manual and the Engine Manual and review at the start of each new season. Pay particular attention to the important Safety Instructions and to the Warning Decals on the unit.

2.3 FUEL REQUIREMENTS - 2 CYCLE ENGINE

⚠ WARNING ⚠
 USE A 50:1 RATIO GASOLINE/OIL MIXTURE ONLY IN THE **SNAPPER LE317 OR LE319 SNOW THROWER.**

A. For proper lubrication, the engine must operate on an exact mixture of gasoline and 2 cycle air-cooled engine oil. Use a 50 to 1 mixture. Use a good quality regular grade leaded or unleaded gasoline and **SNAPPER** special formulated 2-cycle engine oil. The 50 to 1 ratio equals 2.56 ounces of oil to each gallon (U.S. Standard) of gasoline, (or 10.24 oz. to 4 gallons gasoline). Refer to the following chart for correct 50 to 1 ratio mixtures:

50:1 RATIO - U.S. STANDARD FLUID MEASUREMENTS					
GALLONS GASOLINE	1	2	3	4	5
OUNCES 2-CYCLE OIL	2.56	5.12	7.68	10.24	12.80

B. Pre-Mix the fuel in an approved container while observing all safety precautions relating to handling of fuel. Add some gasoline first, then the oil. Close the container and shake vigorously to thoroughly mix the fuel; open the container and add the remaining amount of gasoline to correct the ratio. Shake the container to mix the fuel each time before filling the fuel tank. **DO NOT** add fuel to unit while hot...allow engine to cool for 10 minutes.

2.4 FUEL PRECAUTIONS

⚠ DANGER ⚠
 GASOLINE IS HIGHLY FLAMMABLE! DO NOT SMOKE WHILE HANDLING OR NEAR GASOLINE! DO NOT USE OR STORE GASOLINE NEAR OPEN FLAME OR SPARK-PRODUCING DEVICES!

- A. Fuel is highly volatile. Keep safely away from ignition producing appliances and in well-ventilated area where fumes can be dissipated. Fill fuel tank with correct gasoline/oil mixture as specified in the Engine Owner's Manual.
- B. Wipe up any spilled fuel.
- C. Do not use fuels which have been sitting for a long period of time (one month maximum).

2.5 OPERATIONAL CONTROLS - IDENTIFICATION & LOCATION (Refer to Figure 1.1)

- **PRIMER** - Located at center of Control Panel. Used to inject fuel into the carburetor during initial startups.
- **CHOKE** - Red Knob located in slot in the bottom cover on the L.H. side of the machine. Moves to the right to choke. Used during initial engine startups.
- **IGNITION SWITCH & KEY** - Located at center of Control Panel. Used to turn engine on or off.
- **PULL ROPE & KNOB** - Located at center of Control Panel below Primer & Keyswitch. Used to start engine.
- **ELECTRIC START BUTTON (If Equipped)** - Black Button on the Control Panel on the R.H. side. Depress to activate Electric Starter, and release to deactivate Electric Starter.
- **ELECTRIC START 110 Volt (Household Current) Receptacle** - Male Terminals located in recess in bottom cover on the R.H. side.
- **AUGER CLUTCH CONTROL** - Wire form located on the top side of the Upper Handle. Rotates back and downward causing the Auger to rotate. Releasing the control will allow it to return to its original position and stop rotation of the Auger.
- **UPPER HANDLE** - Extending rearward from Top Cover. Used to control motion of the unit. By lifting upward slightly (approximately 1 1/2") on handle and rotating the Auger Clutch Control rearward, the Auger will contact the ground and propel the unit forward.

Section II - MACHINE OPERATION

- **CHUTE ROTATOR HANDLE - UNIT LIFT HANDLE** - Located slightly above the Top Cover & attached to the Discharge Chute. Used to change the direction in which snow is to be thrown from left to right. Intermediate Cross Bar with this handle can be used to lift the unit off the ground. **CAUTION** - Use extreme caution when lifting - wear boots and do not over exert yourself.
- **DISCHARGE CHUTE** - Located at front of the Top Cover and extending upward. Used to channel and control the snow being discharged when the Auger is rotating.
- **DISCHARGE DEFLECTOR** - Attached to the top of the Discharge Chute. Used to control the distance in which snow can be thrown 3 to 20 feet. Adjustment made by loosening a wing nut and pivoting the Deflector upward for greater distance or downward for shorter distance.

2.6 PRE-START CHECKS (Refer to Figure 2.1)

- ✓ **CHECK GUARDS AND COVERS** to make sure all are in position and securely tightened.
- ✓ **CHECK AUGER CLUTCH CONTROL** to make sure it is free of obstructions.
- ✓ **CHECK AUGER HOUSING** to make sure it is free of obstructions.
- ✓ **CHECK CHUTE ROTATION** to see if it will rotate freely, positively hold in selected position and does not rotate beyond 100° of centerline.
- ✓ **CHECK DEFLECTOR** to make sure it pivots freely and that the locking handle holds it securely in the selected position.

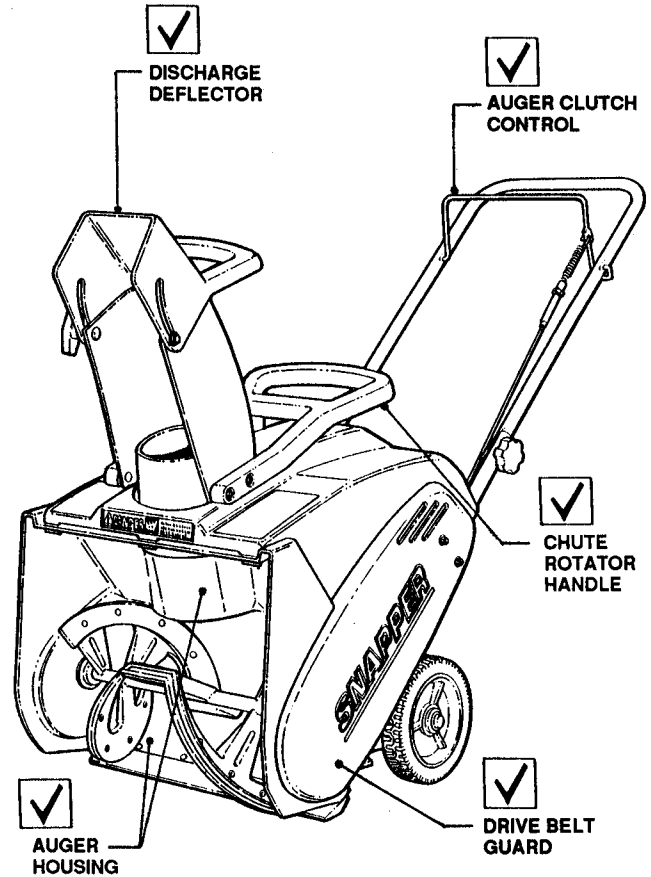

FIGURE 2.1

2.7 START/STOP PROCEDURE



ALWAYS START/STOP UNIT OUTDOORS.
CARBON MONOXIDE CAN KILL!



- A. STARTING/STOPPING ENGINE** - The engine is stopped by turning the Ignition Key to "OFF". Always remove the Ignition Key when leaving the Snow Thrower unattended. Start the engine after performing the foregoing Prestart Checks.
1. Prime - See Engine Owner's Manual. Prime as instructed in manual.
 2. Choke - Move the Choke Lever to the right.
 3. Ignition - Turn the Ignition Key to "ON".
 4. Stabilize Machine - Place hand on Upper Handle and hold securely.
 5. Pull Rope - With remaining hand, pull recoil rope handle with smooth rapid movement until engine starts. If engine fires, but does not start after several attempts, move Choke Control to the left and pull Starter Rope again. Do not allow handle to snap back.

Section II - MACHINE OPERATION

6. Electric Start (If So Equipped) -
(Tecumseh & Decal)
Connect Power Cord to Starter Switch Box on panel, then plug the other end into a 120 volt AC receptacle. Push Starter Button in until engine starts - do not hold button for more than twenty seconds to avoid damaging Starter Motor. After engine starts, disconnect Power Cord from the AC receptacle first, then unplug from the switch box on the Snow Thrower.

- B. After the engine has started, move the Choke Lever to the left slowly. If the engine falters, it may become necessary to move the Choke Lever back to the right slightly. When the engine has smoothed out, move the Choke Lever fully to the left.

2.8 OPERATION (ALSO SEE SECTION III SNOWTHROWING TECHNIQUES)

 CAUTION 
OBSERVE SURROUNDINGS FOR ANY VEHICULAR TRAFFIC OR OBSTACLES. TAKE NOTE OF WIND DIRECTION AND CONDITION OF SNOW (LIGHT FLUFFY, MODERATE, HEAVY WET). OPERATE SNOW THROWER ONLY IF CONDITIONS ARE SAFE.

- A. Rotate Chute to the direction in which you would like to throw the snow.
- B. Adjust Discharge Deflector upward or downward to achieve the desired distance.
- C. Move back to the Operator Position and move the unit to the area to be cleared.
- D. Move the Auger Clutch Control down to the Handle and start the Auger rotating. Lift the Upper Handle slightly tilting forward onto Auger flighting which allows the unit to pull itself into the snow. You will have to adjust the rate at which you move through the snow to match the snow condition and unit performance. During extreme wet heavy snows, it may be necessary to remove less than a full width.
- E. At some point, you will need to change directions when clearing snow. Always turn the Discharge Chute to direct the snow onto uncleared areas (preferably downwind) and adjust the deflector accordingly for conditions.
- F. When you have completed throwing snow, move the unit to a cleared area. Brush excess snow off unit. Let unit run with Auger rotating for a period of 5 minutes. Turn unit "OFF" and return to storage.

Section III - SNOWTHROWING TECHNIQUES

3.1 The following Snowthrowing Techniques are intended as a guideline for safe operation of the **SNAPPER LE317 and LE319 SNOW THROWERS**. Please read these instructions carefully. Observe **ALL SAFETY PRECAUTIONS, DECALS & INSTRUCTIONS** found in the Operator's Manual and on the machine. Also, read the accompanying booklet "SNOW THROWER SAFETY" and heed the instructions found therein.

A. Throw Snow Downwind - Allow the wind to carry the snow further from the area. See Figure 3.1.

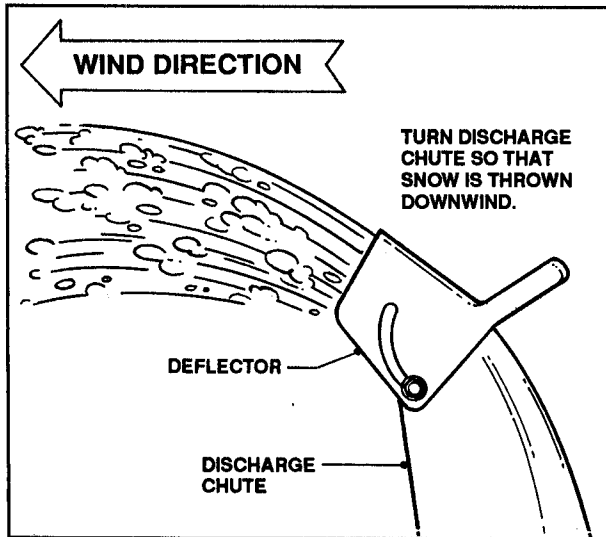

FIGURE 3.1

B. On wide areas, such as driveways, start in the middle and throw snow to the right or left and on the return, throw the opposite direction. See Figure 3.2.

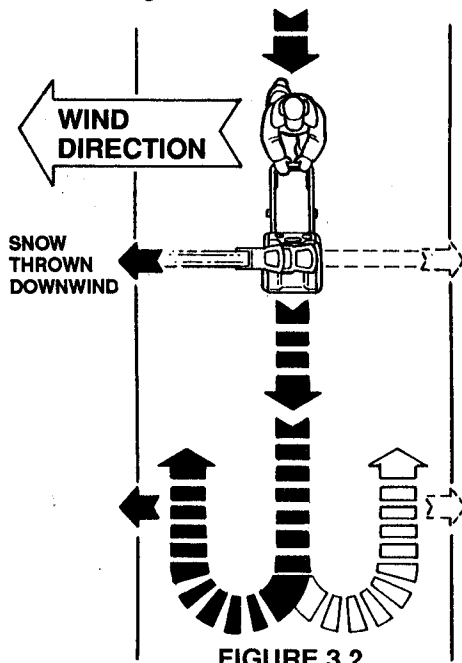
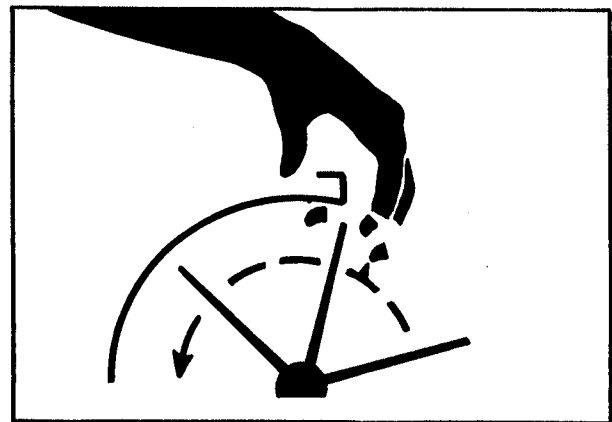

FIGURE 3.2

- C. When approaching the corner of a building, reposition the Deflector downward. This will prevent the wind swirling around the corner carrying the snow in your face.
- D. Take narrowed or slower cuts during extremely heavy or deep snow falls.
- E. Discharge Chutes can plug. This Chute has been designed to aid in freeing a plug.
 1. Release the Auger Clutch Control.
 2. Push Upper Handle downward, raising the Auger Housing off the ground.
 3. Release the Handle and allow the Auger Housing to free fall to the ground. This should discharge the plug.
 4. Activate the Auger Drive once more and this should blow the plug out.

! DANGER !
<p style="text-align: center; margin: 0;">NEVER PLACE YOUR HAND IN THE DISCHARGE CHUTE WITHOUT FIRST TURNING THE ENGINE OFF AND REMOVING THE SPARK PLUG WIRE.</p>



Section IV - SERVICE

TOOLS REQUIRED

1/2" wrench, 1/2" socket (& ratchet) Flat Blade & Phillip Screwdrivers, adjustable wrench and #30 Torx Head Screwdriver.

4.1 The LE317 & L3319 Snow Throwers have been designed in such a manner that most service areas are accessible by removing the Bottom Cover, allowing access to the Fuel Tank, Carburetor, and Recoil.

Contact your **SNAPPER** dealer for service assistance and/or replacement parts for your Snow Thrower. Use only **SNAPPER / TECUMSEH** replacement parts.

4.2 AUGER CLUTCH/BRAKE ADJUSTMENT

It may become necessary to make this adjustment if the Drive Belt is slipping, resulting in poor discharge performance or if the Auger does not stop within 5 seconds after release of the Auger Clutch Control.

Pull the Auger Clutch Control down against the Handle and measure the Spring Extension. Proper Extension should be 1/2" to 3/4". See Figure 4.1.

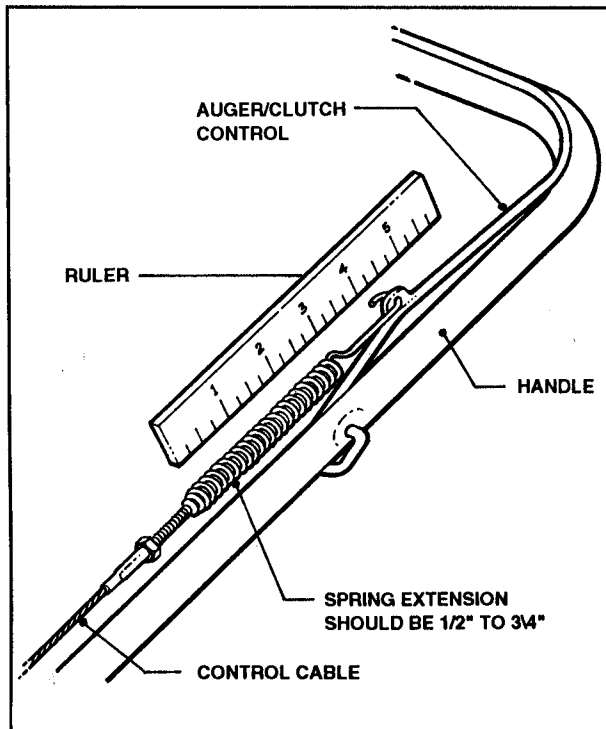

FIGURE 4.1

If Extension is less than 1/2", adjust as follows:

A. Remove Belt Cover. See Figure 4.2.

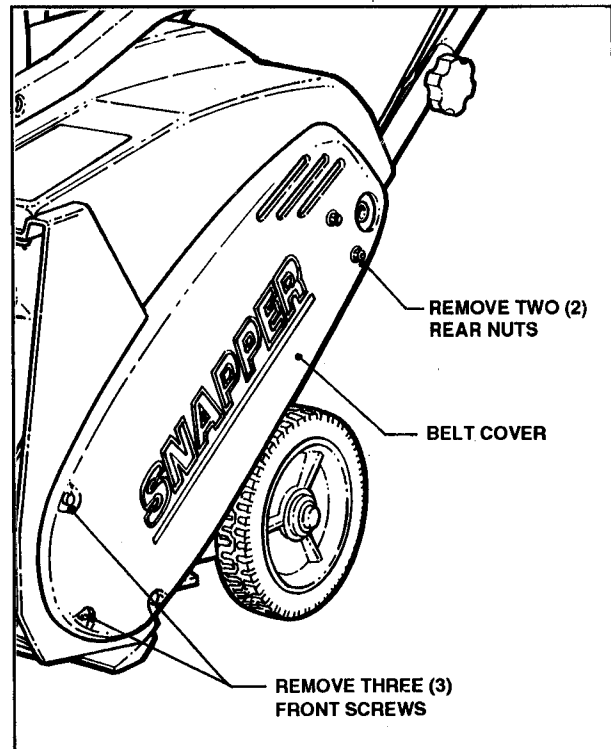

FIGURE 4.2

B. Loosen Idler and move downward in Slot and retighten. Refer to Figure 4.4.

C. Depress Auger Clutch Control and recheck Spring Extension. Refer to Figure 4.1.



CAUTION

DO NOT SHORTEN CONTROL CABLE TO COMPENSATE FOR BELT WEAR. SHORTENING THE CABLE WITHOUT REPOSITIONING THE IDLER WITHIN THE SLOT CAN REDUCE BRAKE EFFECTIVENESS.

D. If the Auger is not stopping within 5 seconds, it may be necessary to move the Idler further down in the Slot.

Section IV - SERVICE

4.3 DRIVE BELT REPLACEMENT

It may become necessary to replace the Belt if the Belt is badly worn, cracked or broken - or if adjustment of the Auger Clutch no longer improves performance.

To replace the Drive Belt (SNAPPER P/N 24618) proceed as follows:

- A. Remove the Belt Cover.
- B. Loosen the Idler and move upward in the Slot.
- C. Remove Belt from large Auger Drive Pulley.
- D. Remove 5/16" nut and washer retaining the Belt Guide.
- E. Loosen the 5/16" nut at the base of the Pulley Guide, sufficient to allow it to pivot. See Figure 4.3.

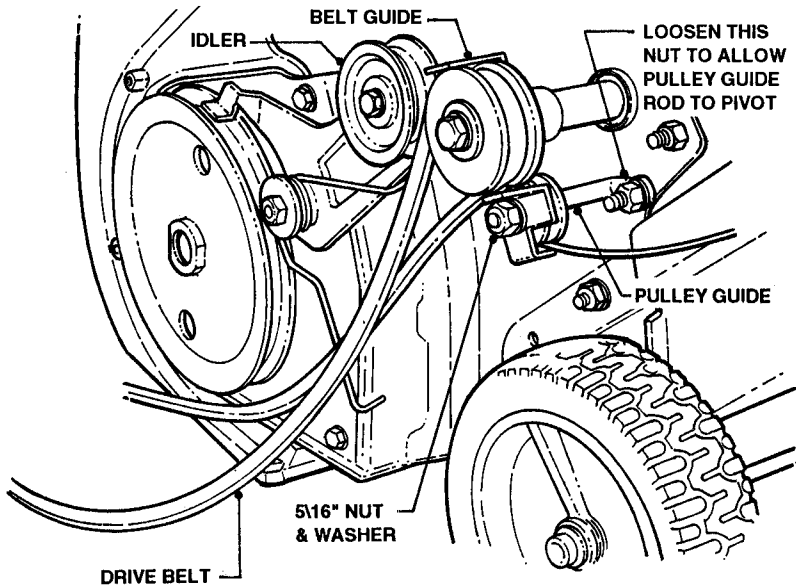

FIGURE 4.3

- F. Remove Belt Guide.
- G. Reinstall new Belt by reversing this procedure. Position Belt Guide as shown in Figure 4.4

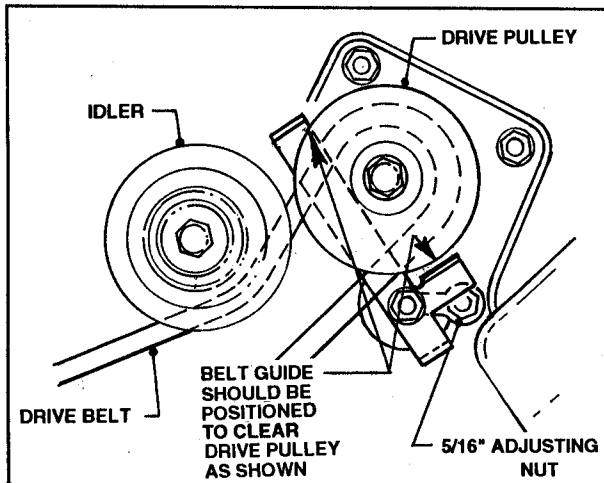

FIGURE 4.4

- H. Adjust Auger Clutch/Brake as described above.
- I. Further adjustment may be necessary after operating unit for a few hours.

4.4 ADJUSTMENTS

NOTE

DO NOT MAKE UNNECESSARY ADJUSTMENTS. FACTORY SETTINGS ARE SATISFACTORY FOR MOST APPLICATIONS AND CONDITIONS. IF ADJUSTMENTS ARE NEEDED, PROCEED AS FOLLOWS:

A. CARBURETOR

If you think your Carburetor needs adjusting, see your nearest AUTHORIZED TECUMSEH SERVICE OUTLET.

Engine performance may be affected in altitudes above 4,000 feet. To improve engine performance, install a High Altitude Adjustment Kit. To obtain a kit, see your nearest AUTHORIZED TECUMSEH SERVICE OUTLET.

Also, provision for the High Altitude Adjustment Kit has been made in the Bottom Cover. Note .25 Dia. Recess on Inside of Bottom Cover. See "INSTALLATION OF HIGH ALTITUDE JET", Section IX, Item 9.1, Page 23.

B. ENGINE SPEED



CAUTION



NEVER TAMPER WITH ENGINE GOVERNOR WHICH IS FACTORY SET FOR PROPER ENGINE SPEED. OVERSPEEDING ENGINE ABOVE FACTORY HIGH SPEED SETTING CAN BE DANGEROUS.

Changing of Engine Governed Speed will void Engine Warranty.

Section V - MAINTENANCE

5.1 It is important to provide good maintenance for your **SNAPPER SNOW THROWER**. The better it is maintained, the longer it will last. The following are a few routine maintenance items which you can do. However, if you would prefer, your local **SNAPPER** dealer can perform these and many other services. For the nearest **SNAPPER** Dealer, check your telephone directory under the heading, **LAWN MOWERS**. For engine parts or service, look for a Tecumseh dealer under the heading, **ENGINES - Gasoline**.

5.2 AT THE END OF EACH SEASON:

A. Add a fuel stabilizer to your last tank of fuel.

B. DRAIN FUEL TANK

Drain Fuel Tank and then start Engine and run until Engine stalls. This will eliminate the remainder of fuel in the fuel line and carburetor. IF THIS PROCEDURE IS NOT DONE, YOUR UNIT WILL BE VERY DIFFICULT TO START NEXT SEASON BECAUSE OF CARBURETOR GUM AND CORROSION!

C. FLUSH OUT CHUTE RING (Located Under Top Cover)

The Chute Ring is a rotating member within the Auger Housing. This area can collect sand and grit, during the course of the season, resulting in difficult Chute rotation. Using a garden hose with a nozzle, direct the water stream at this joint and rotate Chute back and forth. This should flush any grit out of the joint.

D. REPLACE SPARK PLUG

Replace the Spark Plug at the beginning of the season. The Spark Plug can be easily accessed thru a round plastic plug located on the L.H. side of the Control Panel. Pry this Plug out. Remove the Spark Plug Wire and, using a 3/4" Spark Plug Socket, remove the Spark Plug. Before installing the new Plug (Champion CJ-8Y), check the gap (0.030"). Install Plug and snap Plastic Plug back in place.

E. LUBRICATE THE SNOW THROWER

(1) Remove the Belt Guard and lubricate the Idler Arm Pivot with WD-40™. (See Figure 5.1).

(2) Also, lubricate the Clutch/Brake Arm Pivot.

(3) Lubricate the Auger/Clutch Control Handle Pivots with a light coat of SAE 30 Engine Oil.

F. CHECK RUBBER FLIGHTINGS CONDITION

The Rubber Flightings enable the Snow Thrower to move forward. However, when badly worn, their propelling action will decline or completely cease. Your **SNAPPER** Dealer is prepared to install new Rubber Flightings.

G. CHECK SCRAPER BLADE

The Scraper Blade allows for a cleaner path. If cracked, broken, or severely worn; poor cleaning will result and damage to bottom of snow thrower may result.

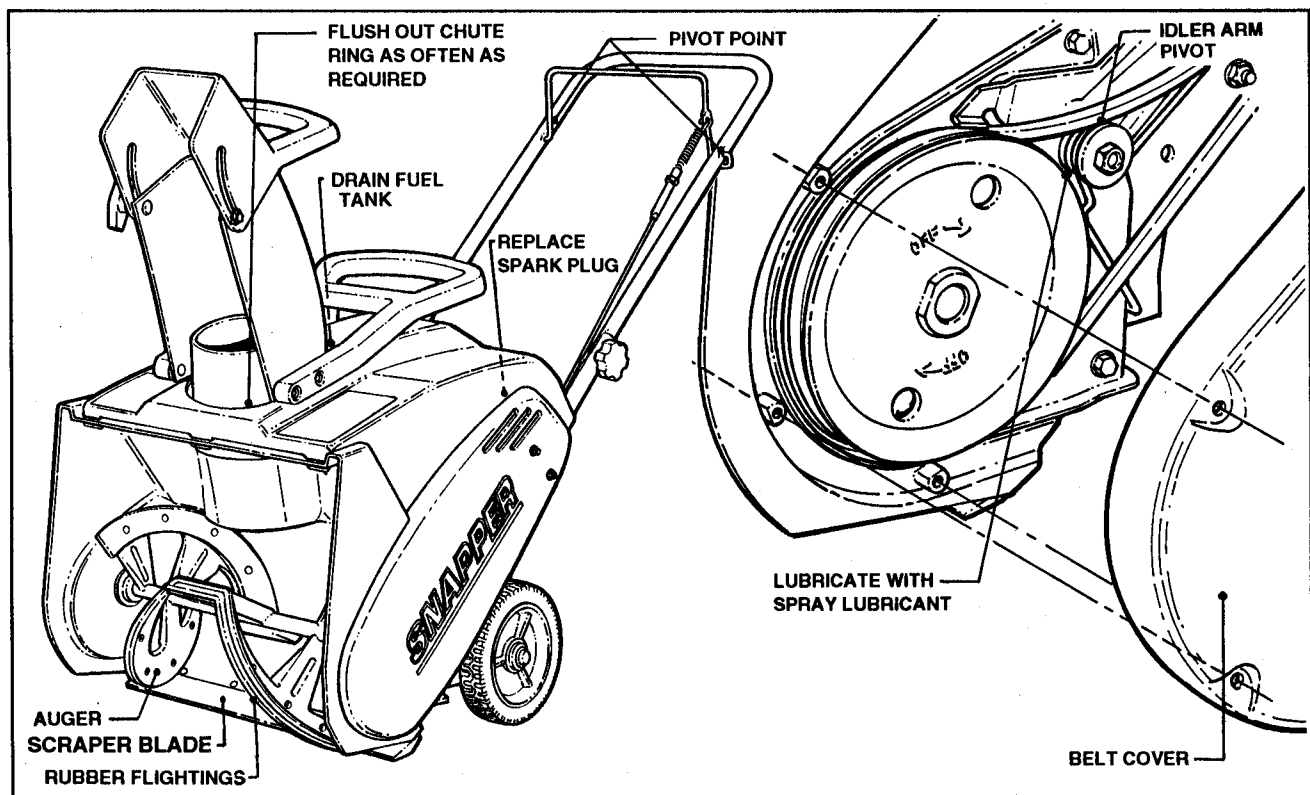

FIGURE 5.1

Section VI - TROUBLESHOOTING

PROBLEM	POSSIBLE CAUSE	PROBABLE SOLUTION	REFERENCES
6.1 Engine will not start	a. Choke Lever is not in "ON" position.	a. Move lever to "ON" position.	OWNER'S MANUAL
	b. Fuel related	b. Fuel tank empty. Fill tank. Stale fuel. Empty tank & fill with fresh fuel.	OWNER'S MANUAL
	c. Ignition related starting problems.	c. Spark plug lead loose or disconnected from plug. Faulty spark plug or faulty electronic ignition. Replace.	Section V, 5.2 - C., Pg. 11
	d. Problems with optional 110 Volt electric start system.	d. Power cord faulty. Replace. Check ignition switch.	Section II, 2.7 - A, 6, Pg. 7
	e. Exhaust Ports plugged.	e. Clean.	ENGINE SERVICE MANUAL
	f. Starter rope recoil system	f. Replace rope recoil unit.	ENGINE SERVICE MAN.
6.2 Engine stalls after starting or running	a. Choke lever left in "ON" position.	a. Move choke lever to "OFF" position.	OWNER'S MANUAL
	b. Fuel tank run dry or fuel line clogged.	b. Refill fuel tank. Unclog fuel line.	OWNER'S MANUAL
	c. Engine carburetor problems	c. Readjust carburetor main fuel setting to specifications in engine manual	ENGINE & OWNER'S MANUAL
	d. Snow conditions too severe for snow throwing technique.	d. Amend technique. Remove less than a full width of snow with each pass.	OWNER'S MANUAL
	e. Operating at high altitude. Engine carburetor is equipped with improper jet.	e. Replace with proper jet.	Section IX, 9.1, Pg.23
	f. Restricted cooling air flow.	f. Ambient temperature above 50°. Wait till it cools to 40° F.	
6.3 Snow Thrower loses self-propelling action	a. Bottom of auger housing in contact with ground	a. Replace scraper bar. Replace auger flighting.	Section VII, 7.3, C & D, Pgs. 15 - 16
	b. Clutch out of adjustment.	b. Adjust clutch.	Section IV, 4.2, Pg. 9
	c. Worn or broken drive belt	c. Adjust or replace belt.	Section IV, 4.3, Pg. 10
	d. Broken Extension idler spring.	d. Replace Control Cable/Spring.	OWNER'S MANUAL
6.4 Doesn't throw snow very well or at all	a. Clutch out of adjustment.	a. Adjust clutch.	Section IV, 4.2, Pg. 9
	b. Worn or broken drive belt	b. Adjust or replace belt.	Section IV, 4.3, Pg. 10
	c. Discharge chute stopped up with snow.	c. Release bail. Tilt unit back. Release handle and let unit drop to ground. Chute should clear itself of snow. Section III, 3.1, E.	Section III, 3.1, Pg. 8
6.5 Discharge chute is difficult to rotate or will not rotate at all	a. Discharge chute is binding. Chute mounting ring is clogged with grit, gravel, etc.	a. Use hose with nozzle to wash out mounting ring	Section V, 5.2, B, Pg.11
	b. Chute rotation detent is jammed into chute mounting ring.	b. Dislodge chute rotation detent (Requires partial disassembly of auger housing)	Section VII, H., Pg. 18
	c. Chute mounting ring or auger housing broken.	c. Replace broken part. (Requires partial or complete disassembly of auger housing).	Section VII, H., I., Pgs. 18-19

Section VI - TROUBLESHOOTING (Cont'd)

PROBLEM	POSSIBLE CAUSE	PROBABLE SOLUTION	REFERENCES
<p>6.6 Discharge chute rotates freely. Will not stay fixed in desired position.</p>	<p>a. Debris jammed between chute rotation detent and chute mounting ring.</p> <p>b. Compression spring(s) in chute rotation detent broken (detent is not locking chute mounting ring in desired position).</p>	<p>a. Remove debris from between detent and chute mounting ring. (Requires partial disassembly of auger housing).</p> <p>b. Replace rotation detent or compression springs (requires partial disassembly of auger housing).</p>	<p>Section VII, H., Pg. 18</p> <p>Section VII, H., Pg. 18</p>
<p>6.7 Excessive noise or vibration when unit is in operation.</p>	<p>a. auger fighting torn loose.</p> <p>b. Auger blade(s) bent or broken.</p> <p>c. Auger shaft bent - auger hits housing when rotating.</p> <p>d. Auger shaft bearings worn out.</p> <p>e. Top housing loose.</p> <p>f. Bottom cover loose.</p> <p>g. All mounting/retaining hardware is loose.</p>	<p>a. Repair/replace auger fighting.</p> <p>b. Repair/replace auger. (Requires auger housing overhaul).</p> <p>c. Replace auger assembly (Requires auger housing overhaul).</p> <p>d. Replace auger bearings.</p> <p>e. Tighten fasteners (If retaining tabs are broken, secure top housing with screws).</p> <p>f. Tighten fasteners.</p> <p>g. Tighten all hardware.</p>	<p>Section VII, D., Pg.16</p> <p>Section VII, E., Pg. 16-17</p> <p>Section VII, E., Pg. 16-17</p> <p>Section VII, F., Pg. 17</p> <p>Section VII, 7.3, A., Pg. 15</p>

Section VII - OVERHAUL & REPAIR (AUGER HOUSING)

7.1 AUGER HOUSING

Shown below in Figure 7.1 are those components which make up the Auger Housing Group. Most of these should be replaced as new parts when doing a complete overhaul of the Auger Housing Assembly.

7.2 CAUSES FOR REPAIR

Most causes for repairs to the Auger Housing are as follows:

A. Tab slots for Top Cover are broken out or Tabs on Top Cover are broken off.

- B. Belt Guard Retaining Screws have stripped out.
- C. Scraper worn out.
- D. Flighting needs replacing.
- E. Auger needs replacing.
- F. Bearings worn out.
- G. Chute Mounting Ring or Rear Throat Housing needs replacing.
- H. Detent or Detent Springs need replacing.
- I. Auger Housing needs replacing.

NOTE: REPAIR INSTRUCTIONS FOR A THRU I CAN BE FOUND ON PAGES 15 THRU 19

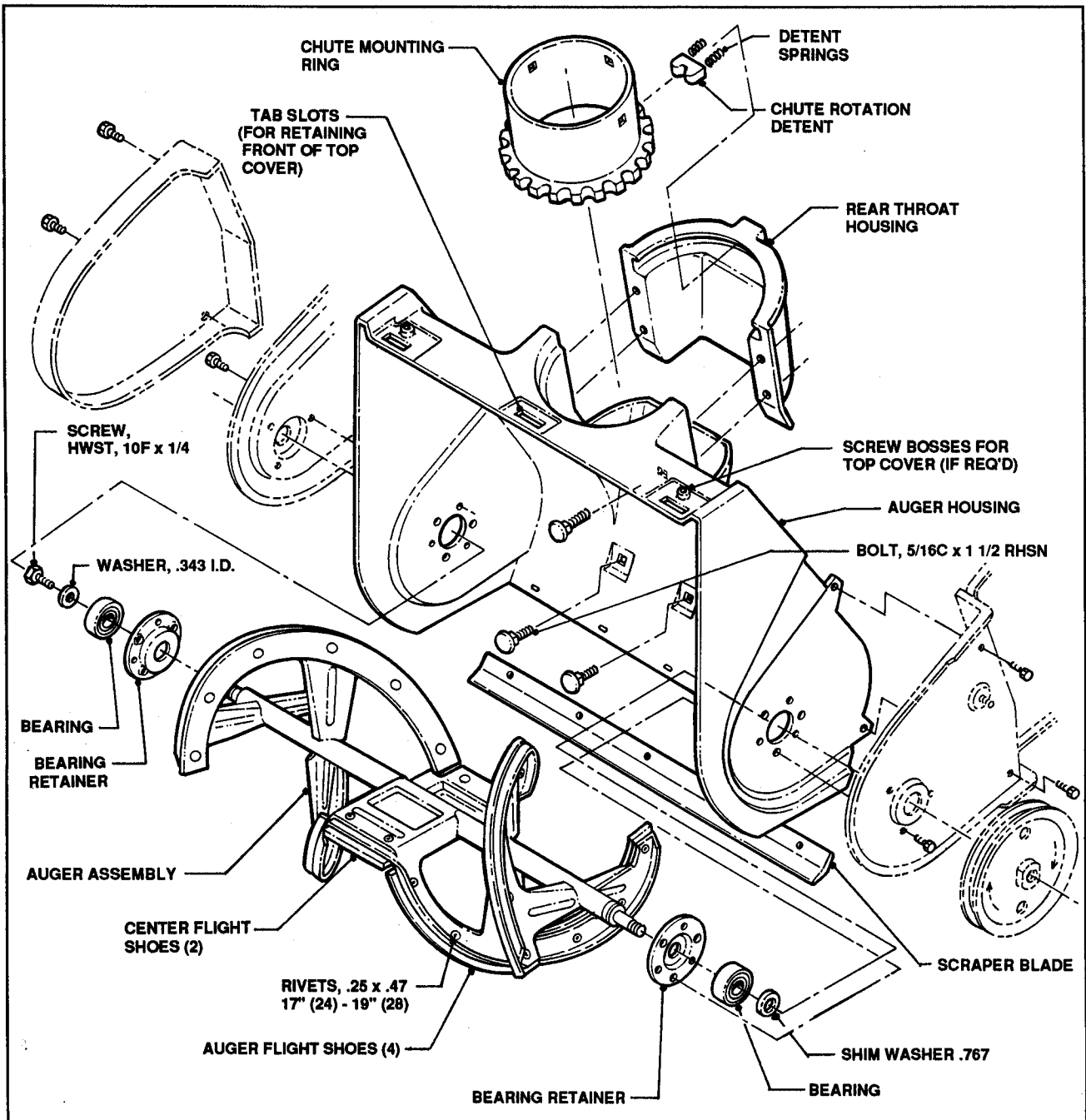

FIGURE 7.1

Section VII - OVERHAUL & REPAIR (AUGER HOUSING)

7.3 AUGER HOUSING OVERHAUL

A. Top Cover is loose due to broken Tabs or Tab Slots. (See Figure 7.2 for example).

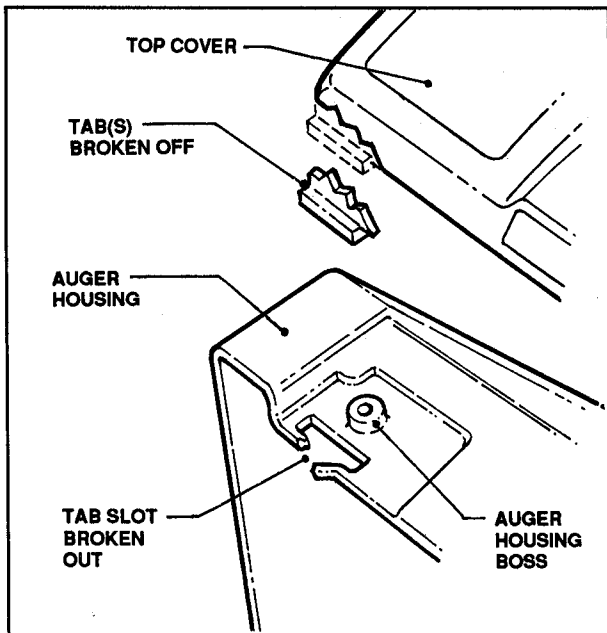

FIGURE 7.2

- (1) Tilt Snow Thrower back on Handlebar.
- (2) From underside, drill through Auger Housing and Top Cover at locations shown in Figure 7.3.

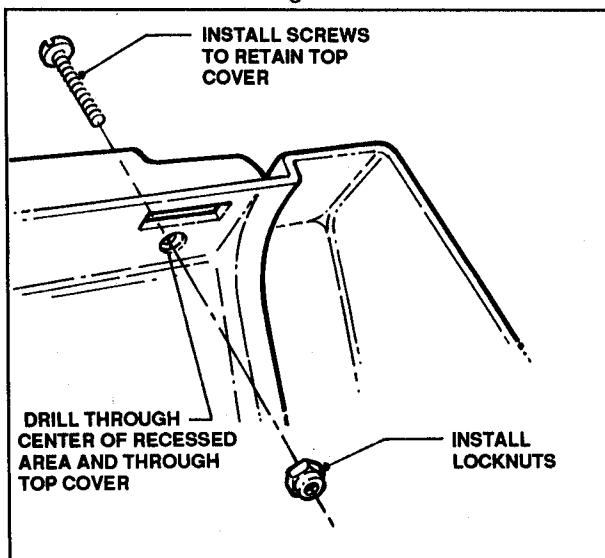

FIGURE 7.3

- (3) Fasten Top Cover to Auger Housing with screws and locknuts.

B. Belt Guard is loose due to stripped-out Retaining Screws.

- (1) Remove three (3) screws from front and two (2) muffler nuts from rear of Belt Guard. Remove Belt Guard.

- (2) Drill through screw holes in bosses on Auger Housing.
- (3) Fasten Belt Guard to Auger Housing with screws and locknuts in front, then replace muffler nuts in the rear. See Figure 7.4.

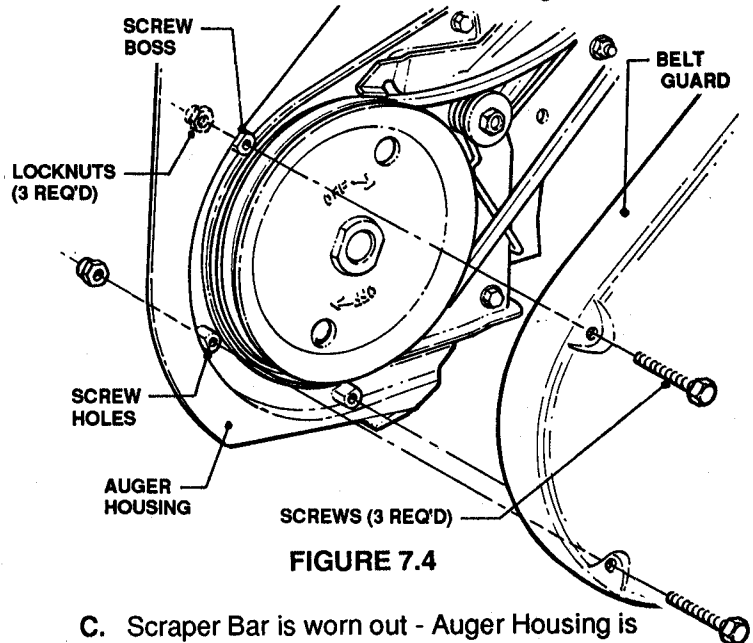

FIGURE 7.4

C. Scraper Bar is worn out - Auger Housing is coming into contact with ground.

- (1) Tilt Snow Thrower back on Handlebar.
- (2) Drill out Scraper Bar retaining rivets (use a 5/16" drill to just "touch" the rolled-ends of the rivets - this will separate the caps, allowing the rivets to be removed). See INSET - Figure 7.5.
- (3) Install new Scraper Blade with kit hardware. (KIT #61235 - 17" - #61236 - 19"). See Figure 7.5.

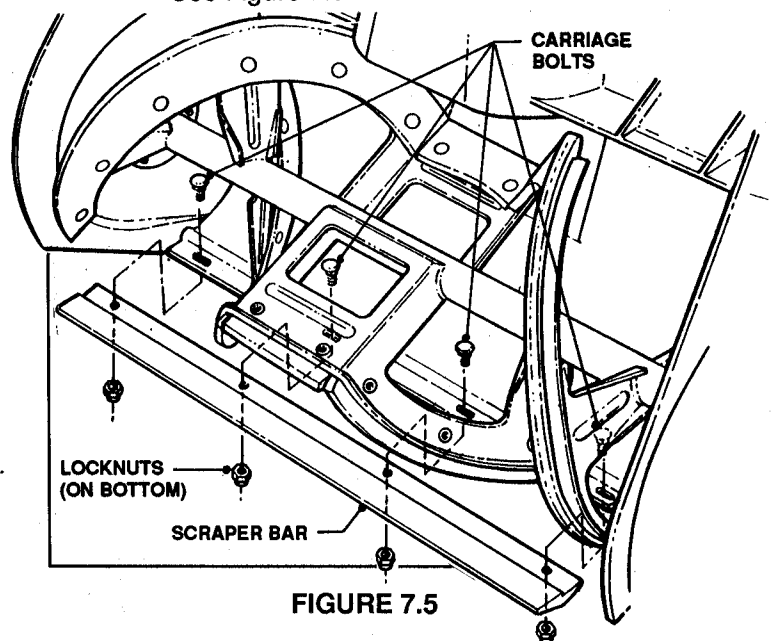

FIGURE 7.5

- (4) Make sure that hardware is installed as shown above.

Section VII - OVERHAUL & REPAIR (AUGER HOUSING)

D. Auger Flighting is worn out - Snow Thrower has loss of self-propelling action.

- (1) Tilt Snow Thrower back on Handlebar.
- (2) Remove worn Flighting by drilling off bottom end of rivets. See Figure 7.6.

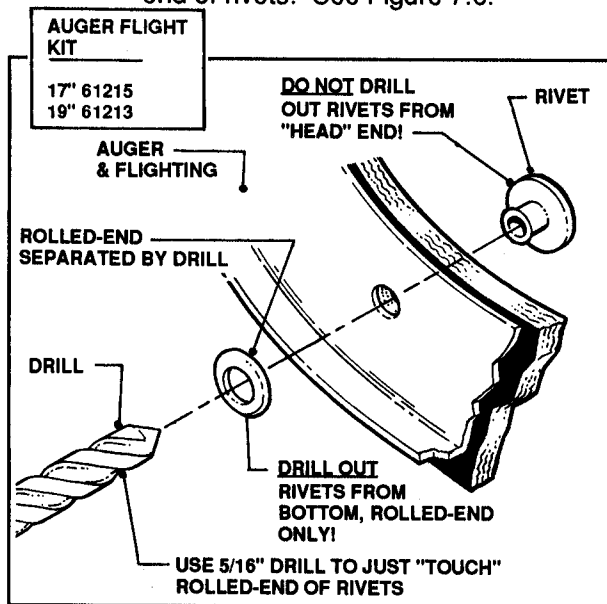

FIGURE 7.6

- (3) Install new Flighting Kit with hardware provided. See Figure 7.7.

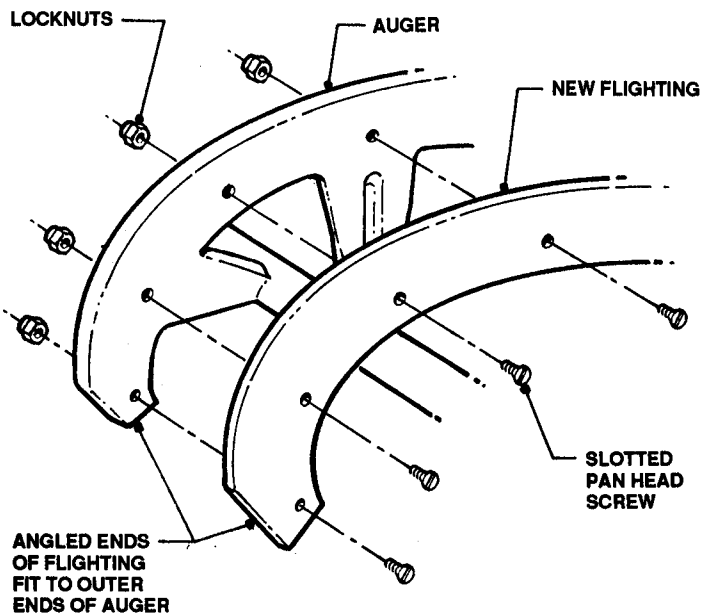

FIGURE 7.7

- (4) After installing new Flighting, spin Auger in Housing to see if it rubs. Trim or grind the Flighting as required to allow free-wheeling.

E. Auger is damaged beyond repair. Requires replacement.

- (1) Remove Belt Guard and R.H. Cover.
- (2) Roll Drive Belt off bottom of Auger Pulley.
- (3) Press down on Idler Pulley and remove Drive Belt from under Keeper. See Figure 7.8.

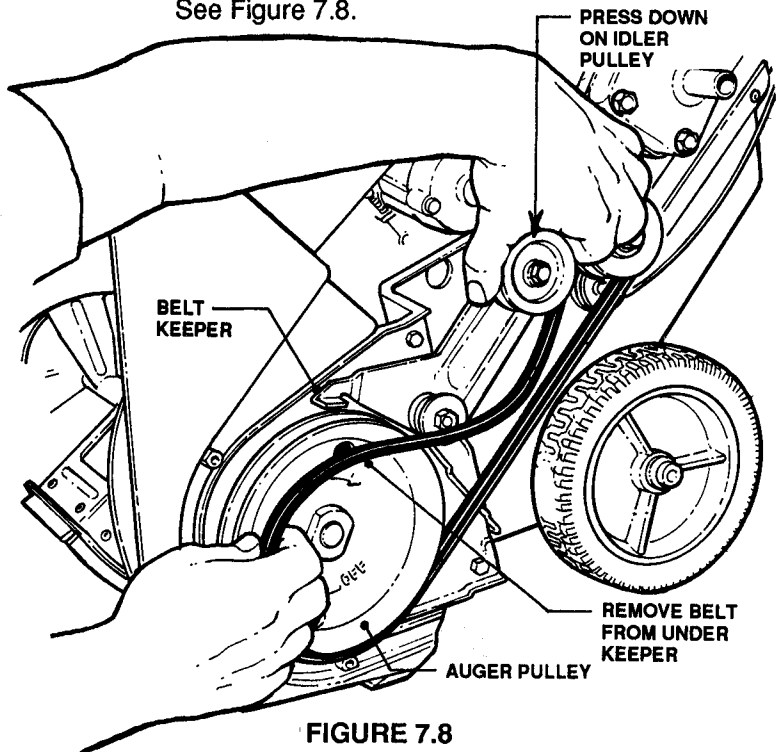

FIGURE 7.8

- (4) Hold Auger and use an adjustable wrench to remove Auger Pulley. See Figure 7.9.

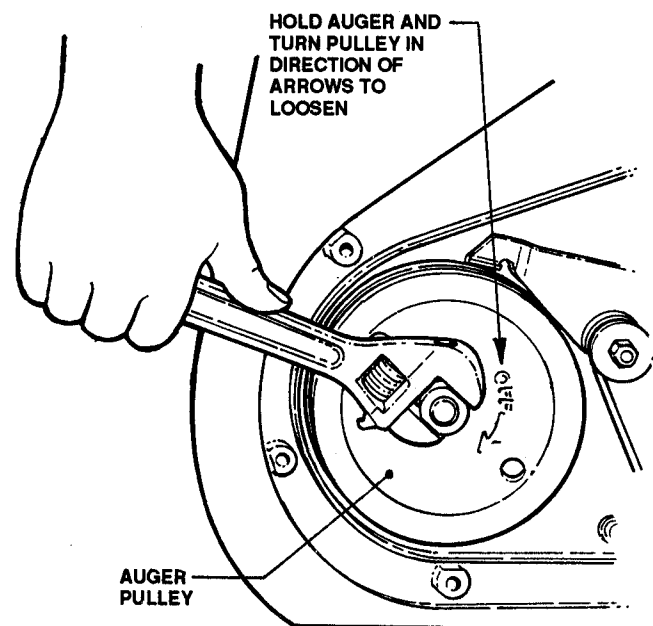

FIGURE 7.9

Section VII - OVERHAUL & REPAIR (AUGER HOUSING)

- (5) Remove three (3) 10F x 1/4" hex washer, self-tapping screws from each side of the Auger Housing. See Figure 7.10.

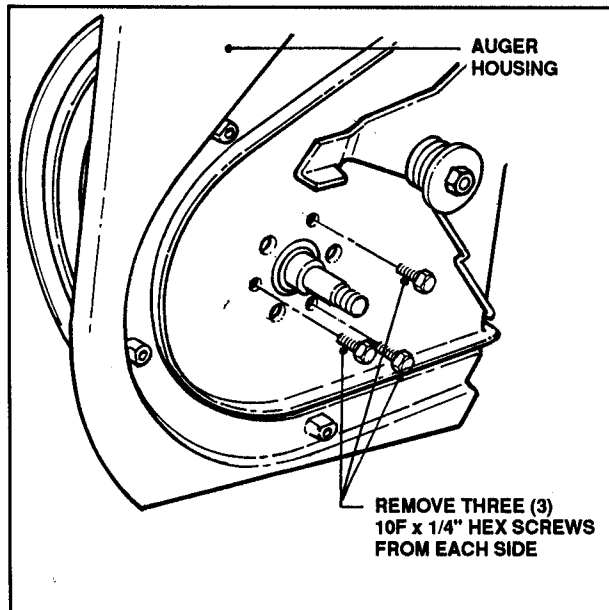

FIGURE 7.10

- (6) Remove the 5/16 x 1/2 ST screw and .34 flat washer from the R.H. end of the Auger Shaft. See Figure 7.11.

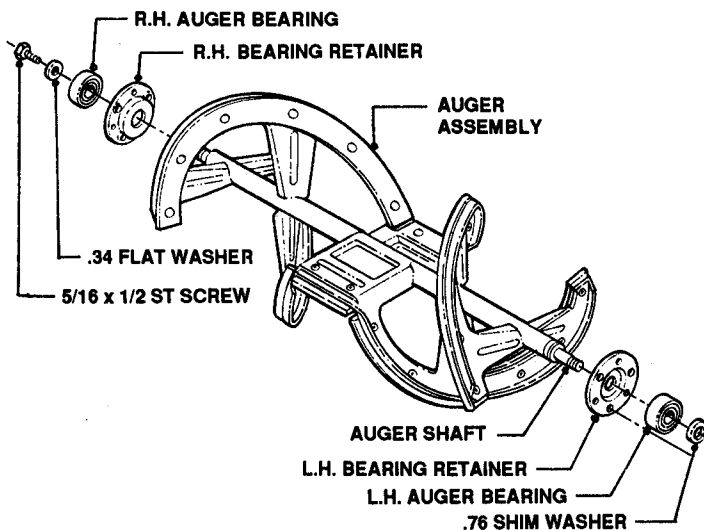

FIGURE 7.11

- (7) Remove the washer and shim washer from the ends of the Auger Shaft.
 (8) Move the left side of the Auger Housing "OUT" enough to free the left end of the Auger Shaft.
 (9) Remove Auger Shaft from Housing.
 (10) Rebuild/Replace and Reinstall Auger in reverse order.

F. Bearings worn out. Replace as shown in Figure 7.11 (above).

- G. Chute Mounting Ring or Rear Throat Housing is broken. Requires replacement.

- (1) Remove Discharge Chute.
 (2) Remove the Top Cover by first removing the two (2) Cover Retaining Screws from under the Push Handle, then lift up on the rear of the Cover and disconnect the Switch, Primer, Gas Tank and Electric Start Button. Disengage the Front Locking Tabs from the Auger Housing. See Fig. 7.12.

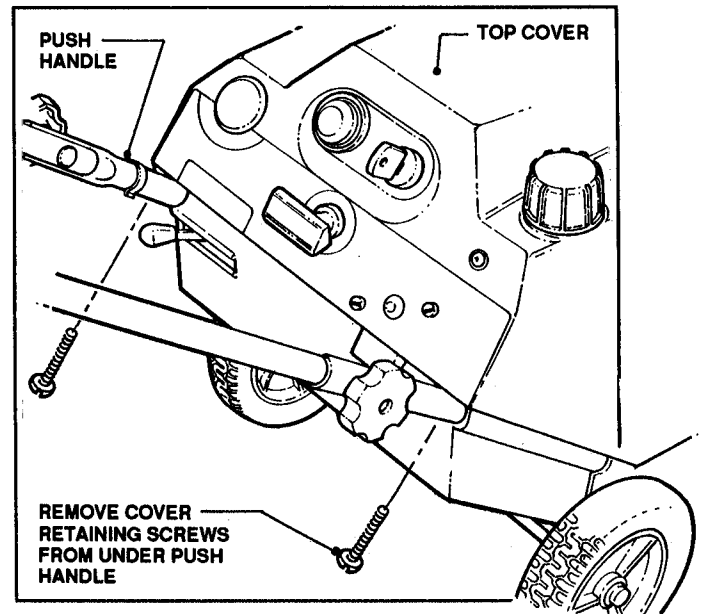

FIGURE 7.12

- (3) Swing Cover up and over the Chute Mounting Ring and out of the way.
 (4) Remove Rear Throat Housing as follows:
 a. Drill out rivets (use a 5/16" drill to just "touch" the rolled-ends of the rivets - this will separate the caps, allowing the rivets to be removed). See Figure 7.13.

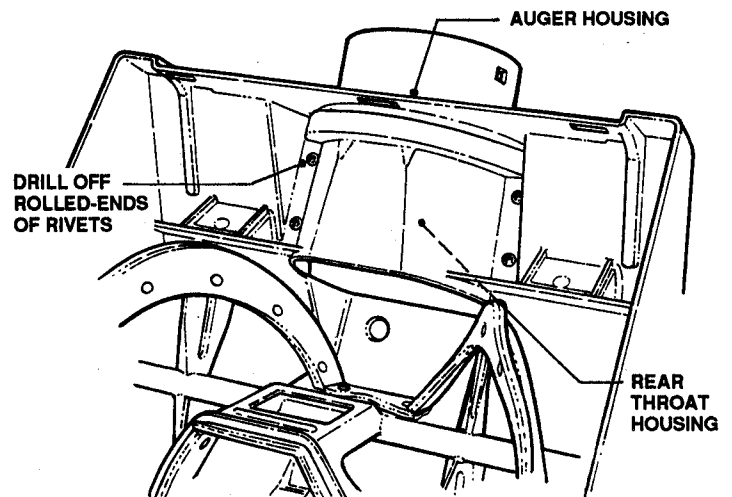

FIGURE 7.13

Section VII - OVERHAUL & REPAIR (AUGER HOUSING)

- (b) Separate Rear Throat Housing and Chute Mounting Ring from Auger Housing.
- (c) Replace parts as required.
- (d) Reattach new parts to Auger Housing with 1/4-20 screws and lock nuts.

H. Detent or Detent Springs worn or broken. Requires replacement.

- (1) Follow steps 1 thru 4, a & b, (G - CHUTE MOUNTING RING/REAR THROAT HOUSING REPLACEMENT).
- (2) Replace Detent or Detent Springs as required. See Figure 7.14.

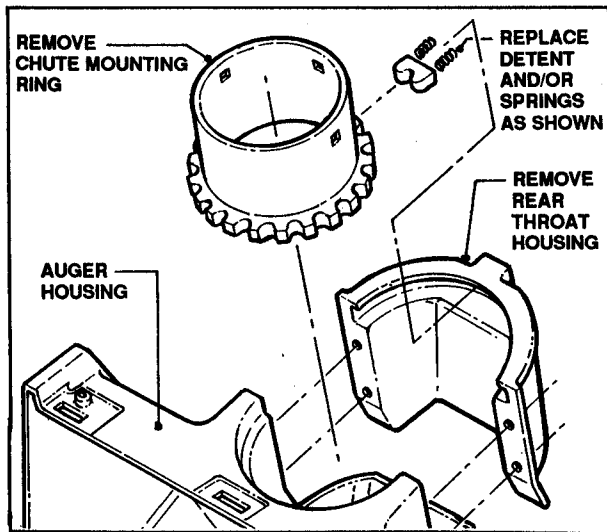

FIGURE 7.14

I. Auger Housing needs replacing.

NOTE

Cracks, holes and extremely scuffed or torn surfaces at any location in the Auger Housing indicate the need for its replacement. Although the removal of all attached parts is required to replace the housing, it should not be necessary to replace all these parts with new ones. Carefully inspect all removed parts for damage or wear. Replace with new parts as required.



CAUTION



DISCONNECT SPARK PLUG. DRAIN GASOLINE FROM FUEL TANK INTO AN APPROVED CONTAINER. REMOVE ANY SNOW, ICE, DIRT OR WATER FROM UNIT BEFORE DISASSEMBLY.

- (1) Remove Choke-Lever Knob and the two (2) screws securing Bottom Cover to Lower Handlebars. Slide Bottom Cover rearward to remove and expose interior of Engine Compartment.

- (2) Disconnect Spark Plug, Fuel Line, Primer Hose, and Electric Start Switch (if installed). Leave the Pull Start Rope engaged through the Top Cover and Pull Handle. The Pull Start Rope will be long enough to allow Top Cover removal and positioning.
- (3) Remove the two (2) nuts at the **FRONT** Base of the Discharge Chute and remove the nut at the Rear Base of the Chute. Remove the three (3) carriage bolts from inside of the Chute Base, and slide the Chute/Handle/Deflector Assembly to the rear of the unit to remove. See Figure 7.15.

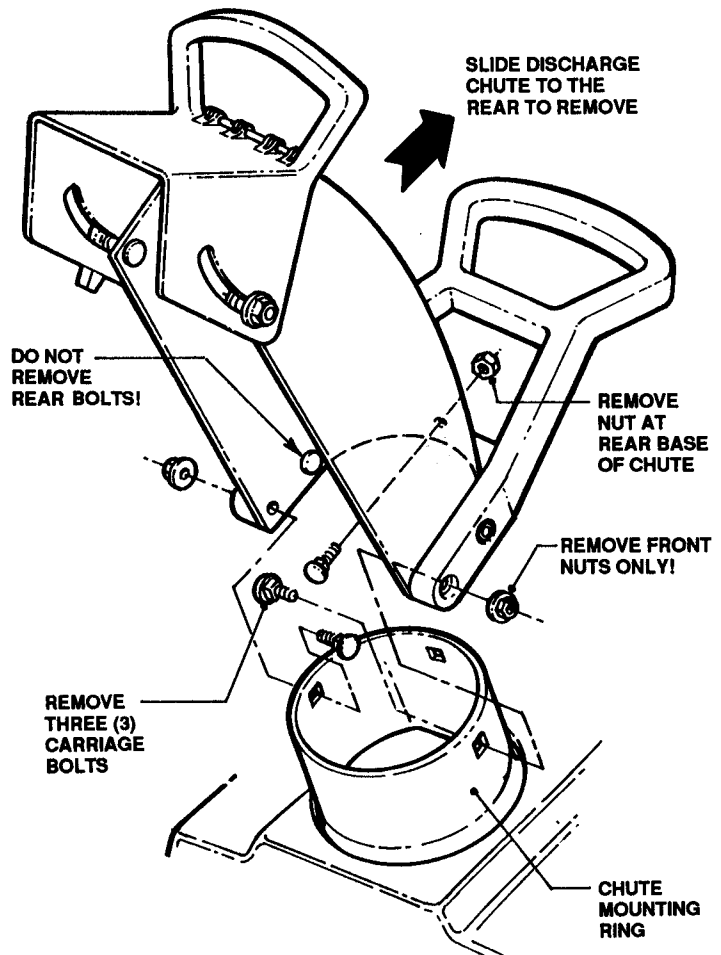

FIGURE 7.15

- (4) Remove two (2) screws at rear of unit which secure Top Cover to Lower Handlebar, and remove Top Cover by tipping forward to unlatch Tabs between Top Cover and Auger Housing front edge. Using full length of Pull Start Rope, remove Top Cover and place Top Cover at rear of unit between Handlebars.
- (5) Remove Belt-Cover by unfastening the three (3) screws on the front and the two (2) nuts near the Exhaust Outlet at the rear of the unit.

Section VII - OVERHAUL & REPAIR (AUGER HOUSING)

- (6) Remove two (2) screws at rear of R.H. End Frame Cover and remove Cover. See Figure 7.16

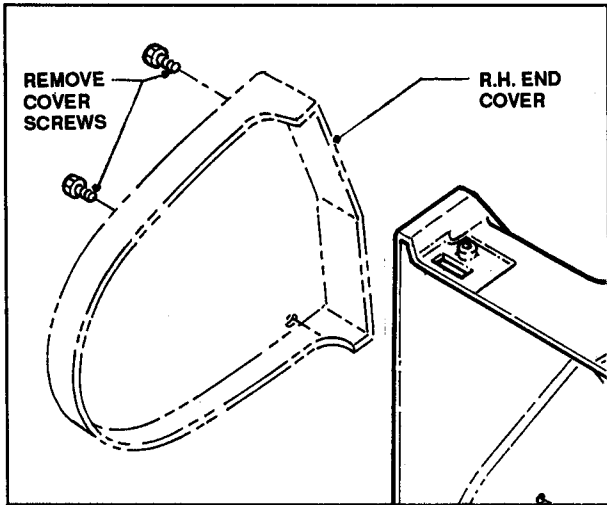

FIGURE 7.16

- (10) Slightly loosen nuts which secure metal Endframes to Lower Handle.
- (11) Remove Auger Housing Assembly and Auger from metal Chassis by slightly spreading metal Endframes to clear Auger Shaft ends.
- (12) Spread sides of old Auger Housing Assembly to remove Auger; keep Bearings and Bearing Retainers in position on Auger Shaft.
- (13) Discard old Auger Housing properly. Spread sides of new Auger Housing Assembly and install Auger (with Bearings and Inner Bearing Retainers in place) in Housing with threaded Shaft end to Engine side of Chassis.
- (14) Reverse steps 1 thru 12 to install new Housing Assembly and reassemble machine.

- (7) Remove Drive Belt from Large Auger Pulley by pressing on Idler-Arm/Pulley to raise Idler-Arm Brake OFF Belt at the Auger Pulley. Use free hand to slip Belt off Auger Pulley. Leave Belt on Engine Pulley.
- (8) Unscrew Auger Drive Pulley from Auger Shaft by holding Auger with left hand and rotating Auger Pulley Clockwise with an adjustable wrench in right hand.
- (9) Remove six (6) small Auger Shaft Bearing Retaining Screws from left and right metal Endframes. See Figure 8.1. Remove four (4) Auger Housing Endframe Screws from machine. Remove two (2) screws which attach right metal Endframe to the metal Engine Brace. Remove nut and bolt which attach Engine Brace to rear throat area of Auger Housing. See Figure 7.17.

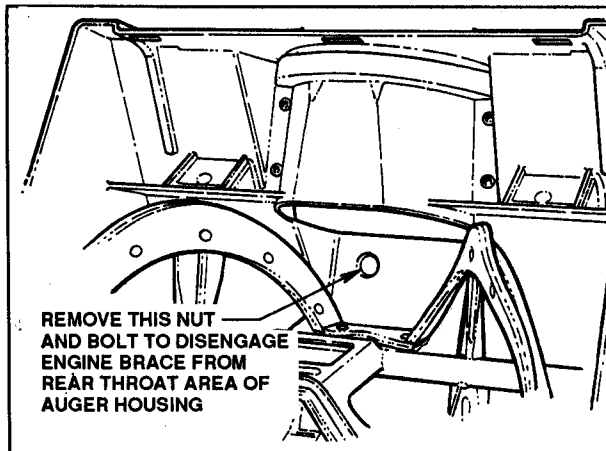

FIGURE 7.17

Section VIII - OVERHAUL & REPAIR (DRIVE SYSTEM)

8.1 DRIVE SYSTEM & CONTROLS

Shown below in Figure 8.1 are those components which make up the Drive System Group. Only those components which are worn, broken or otherwise unserviceable should be replaced as new parts when doing a complete overhaul of the Drive System.

8.2 CAUSE FOR REPAIR (DRIVE SYSTEM)

Most causes for repairs to the Drive System are as follows:

- A. Drive Belt worn or broken.
- B. Cable Guide and/or Belt Guide loose or broken.
- C. Idler Spring is loose or broken.
- D. Engine requires service.

NOTE

REPAIR INSTRUCTIONS FOR A THRU D CAN BE FOUND ON PAGES 21 THRU 22

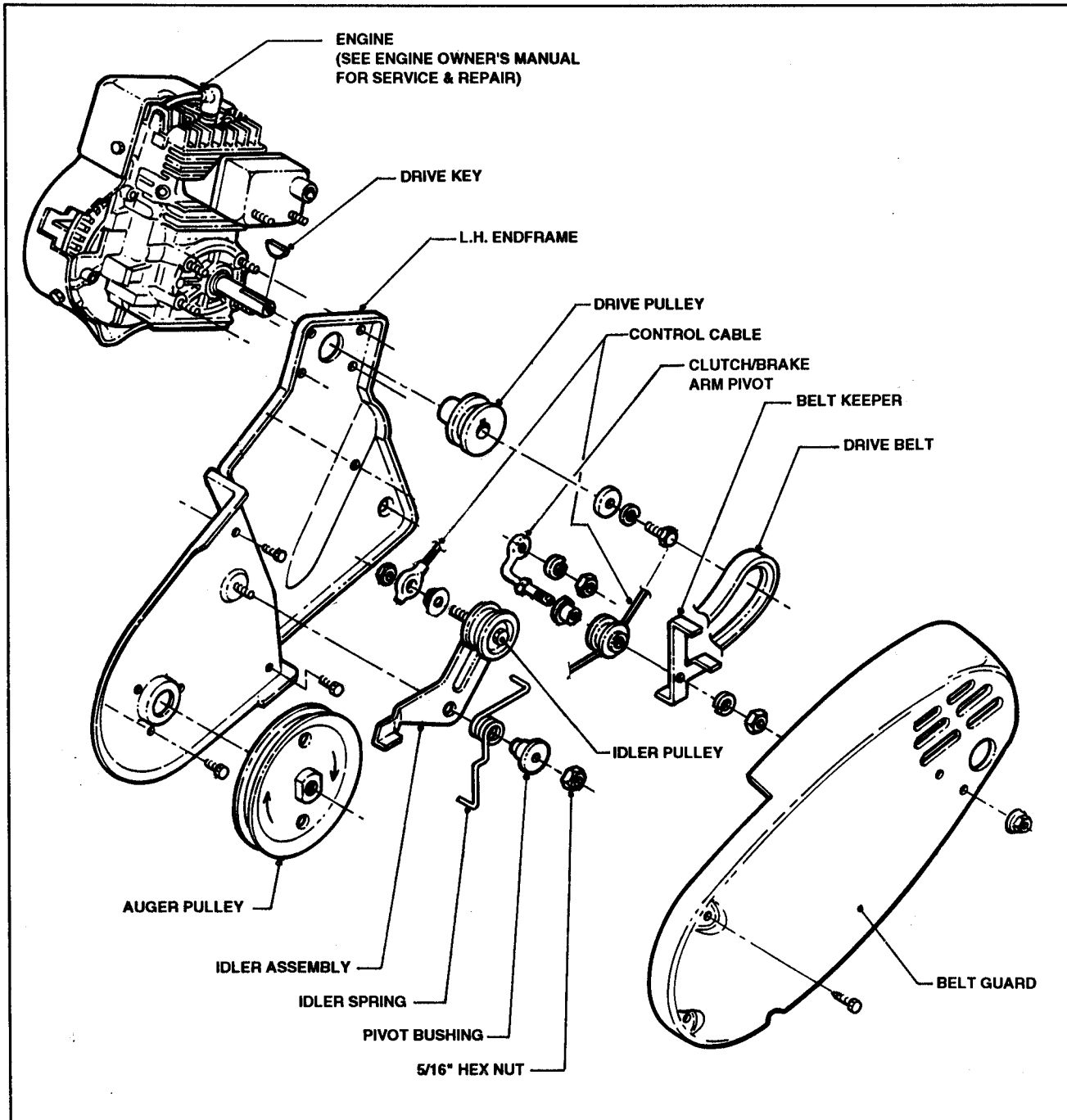

FIGURE 8.1

Section VIII - OVERHAUL & REPAIR (DRIVE SYSTEM)

- A. Drive Belt is worn or broken - Snow Thrower is operating slowly, intermittently or not at all. Belt requires replacement.
- (1) Remove Belt Guard.
 - (2) Roll Drive Belt off bottom of Auger Pulley (if Belt is not broken).
 - (3) Press down on Idler pulley and remove Drive Belt from under Brake. See Figure 8.2.

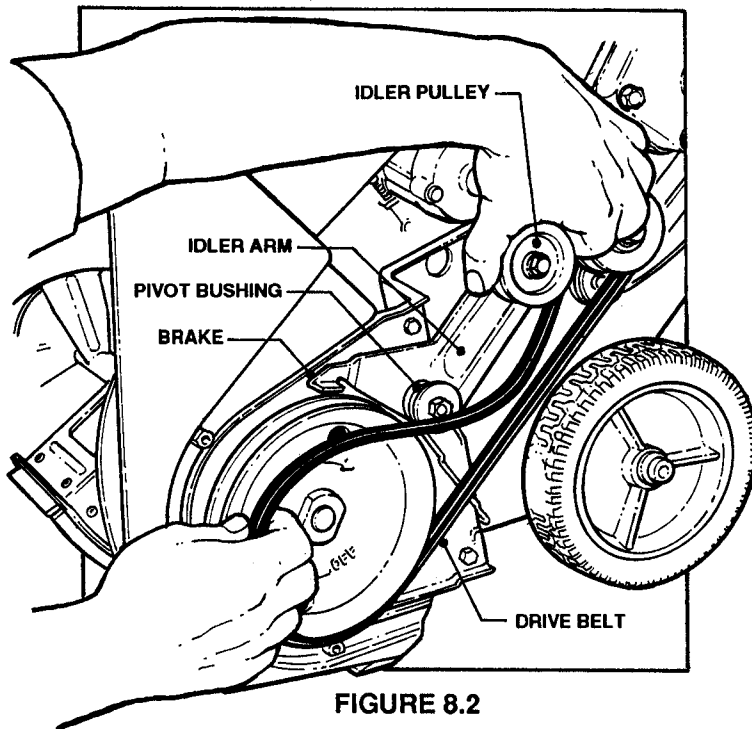

FIGURE 8.2

- (4) Remove 5/16" hex nut and lockwasher retaining the Belt Guide.
- (5) Loosen the 5/16" nut at the base of the Pulley Guide enough to allow it to pivot. See Figure 8.3.

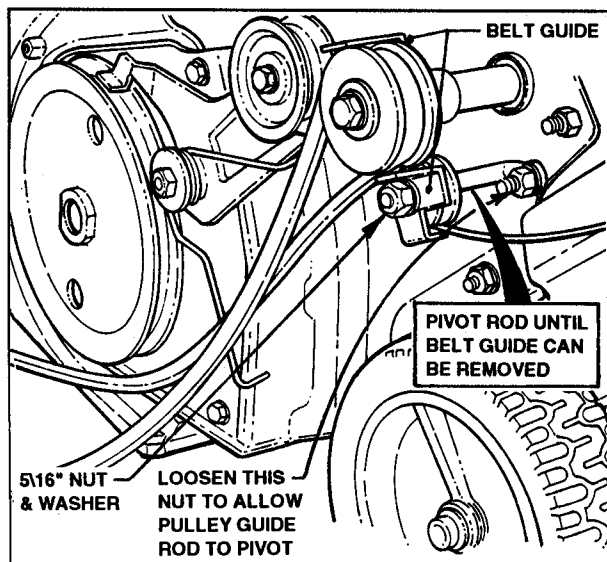

FIGURE 8.3

- (6) Remove the Belt Guide.
- (7) Remove worn/broken Belt.
- (8) Install new Belt in reverse order.
- (9) Position Belt Guide as shown in Figure 8.4.

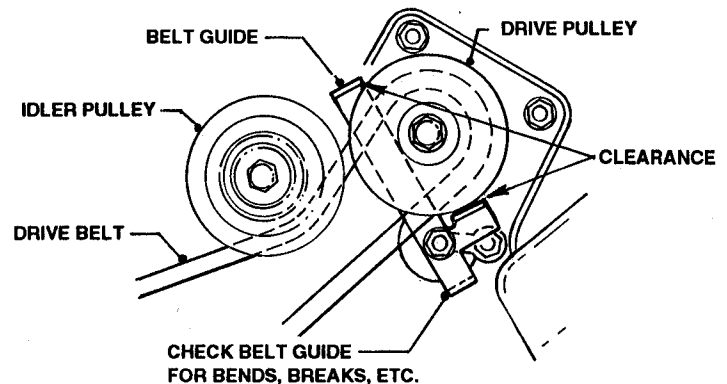

FIGURE 8.4

- (10) Adjust the Auger Clutch/Brake to proper tension.

NOTE
 FURTHER CLUTCH/BRAKE ADJUSTMENT
 MAY BE NECESSARY AFTER OPERATING
 THE UNIT FOR A FEW HOURS.

- B. Cable Guide and/or Belt Guide is loose or broken - Snow Thrower is operating slowly or not at all. Does not respond to Handle Control.
- (1) Remove Belt Guard.
 - (2) Check nut at base of Pulley Guide for looseness. (If nut is loose, then Clutch/ Brake Cable will not be fully operative). Tighten nut if required. See Figure 8.5.
 - (3) Check Pulley Guide and Belt Guide for breaks. Replace either if required.

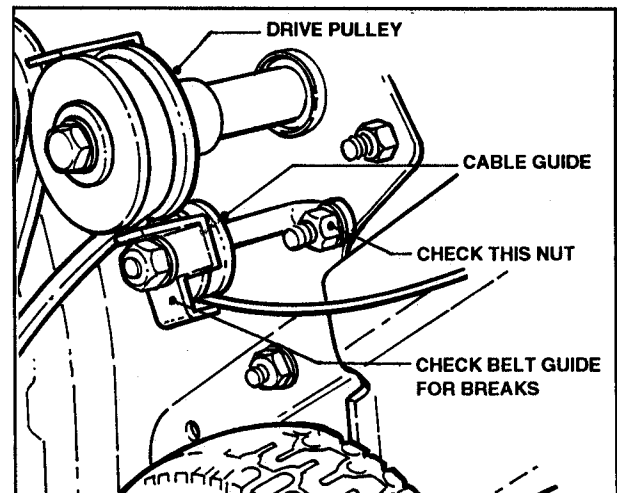

FIGURE 8.5

Section VIII - OVERHAUL & REPAIR (DRIVE SYSTEM)

- C. Idler Spring is loose or broken. Brake is inoperative. Stop time greater than 5 seconds.
- (1) Remove Belt Guard.
 - (2) Check to see if Torsion Idler Spring is loose or broken. If Spring-end is loose, then rehook on rear of housing. (See Pg. 21 Fig. 8.3)
If Spring is broken, proceed with Step 3.
 - (3) Remove 5/16" hex nut retaining Idler Assembly. See Figure 8.6.

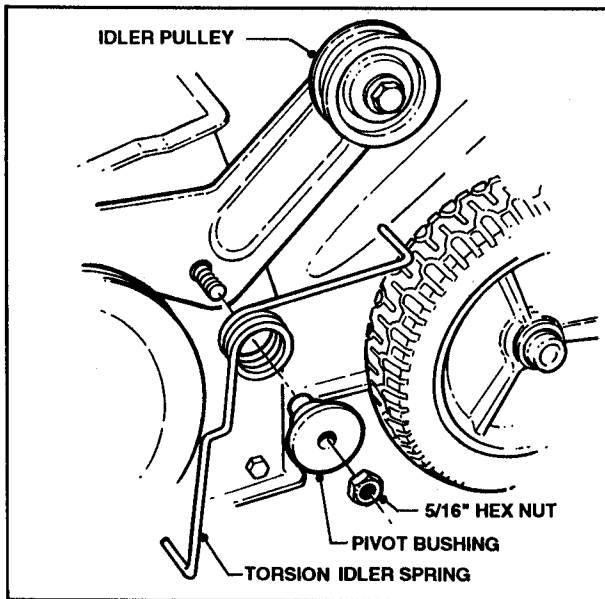

FIGURE 8.6

- (4) Remove Pivot Bushing.
 - (5) Remove broken Spring.
 - (6) Install new Spring and removed parts in reverse order.
- D. Engine requires service. If Engine will not start or will not run satisfactorily, consult the "TROUBLESHOOTING" Chart (Section VI) first and then the Engine Owner's Manual for possible solutions to the problem(s).

Section IX - ENGINE ACCESSORIES

9.1 INSTALLATION OF HIGH-ALTITUDE JET

Engine performance will probably be affected at altitudes above 4,000 feet. To improve engine performance, install the "HIGH ALTITUDE ADJUSTMENT KIT (JET)" - available from an authorized TECUMSEH Service Outlet. Installation is as follows:

- A. Remove Bottom Cover.
- B. Drill a 1/2" diameter hole thru Bottom Cover at location shown in Figure 9.1.

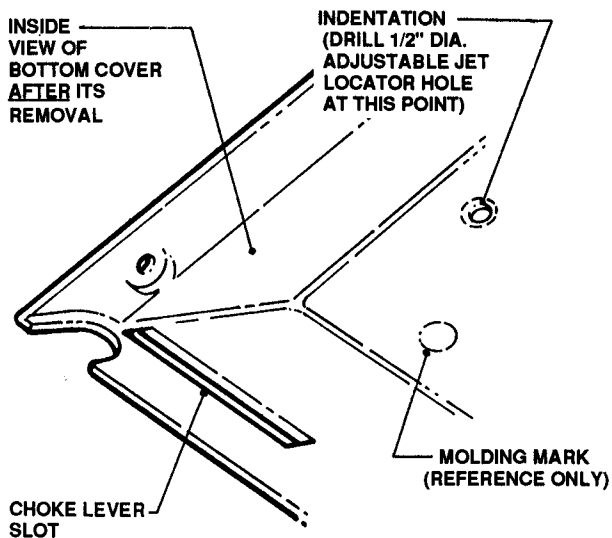

FIGURE 9.1

- C. Remove existing Jet from Carburetor.
- D. Install Adjustable Jet (from kit) in Carburetor.
- E. Adjust Jet per kit instructions.
- F. Replace Bottom Cover.

9.2 INSTALLATION OF ELECTRIC STARTER (17" Snow Thrower only)

Order ELECTRIC START KIT #60608 FROM NEAREST SNAPPER DEALER.

Install Electric Start Kit as follows:

- A. Remove Belt Guard.
- B. Remove Bottom Cover.
- C. Trim Outlet in Bottom Cover as shown in Figure 9.2.

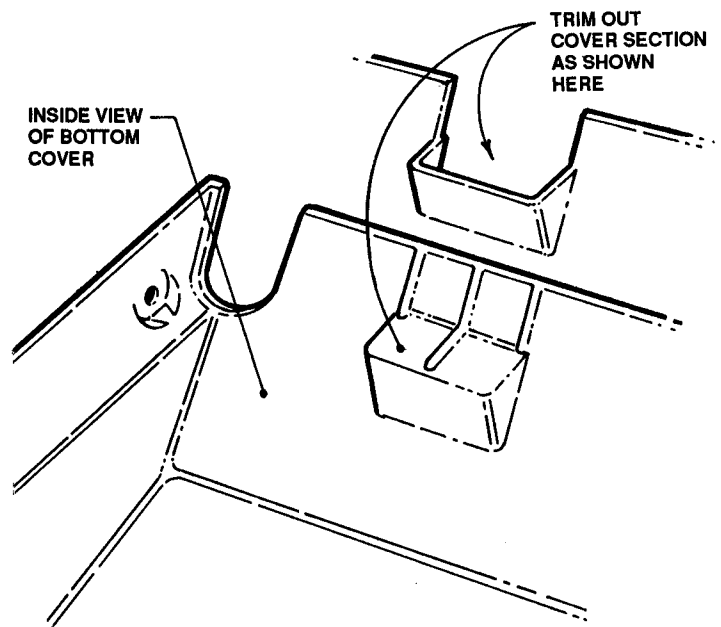

FIGURE 9.2

- D. Using a sharp object, push through Control Panel Decal at the two (2) Cross Hairs located by the Starter Button Hole.
- E. Cut out Starter Button Hole. See Figure 9.3.

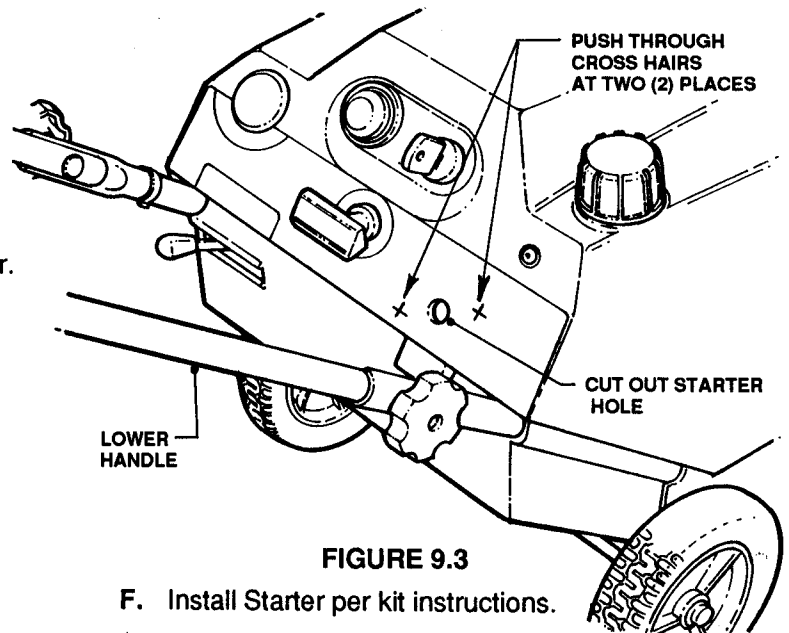

FIGURE 9.3

- F. Install Starter per kit instructions.

NOTE

WHEN INSTALLING THE ELECTRIC START KIT ON THE 17" SNOW THROWER, ADJUST PULLEY DOWN IN ITS SLOT TO INSURE THAT THE IDLER PULLEY WILL CLEAR THE STARTER HOUSING DURING MACHINE OPERATION. ADJUST THE CLUTCH/BRAKE CONTROL CABLE AS REQUIRED FOR CORRECT OPERATION. ACCESS HOLE IN SIDE FRAME FOR DRIVER ACCESS TO STARTER MOUNT SCREW.

SNAPPER® McDonough, GA., 30253 U.S.A.