



INSTALLATION INSTRUCTIONS FOR PART 99-8225G

APPLICATIONS

Toyota Venza 2009-2010

99-8225G

KIT FEATURES

- DIN Head Unit Provision With Pocket
- ISO DIN Head Unit Provision With Pocket
- *Painted to match factory dash - G=Gray*



KIT COMPONENTS

- A) Single DIN Radio Housing
- B) ISO Brackets
- C) Trim Plate

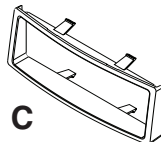
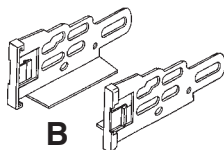
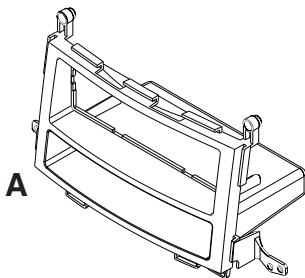

WIRING AND ANTENNA CONNECTIONS

(Sold Separately)

- 70-1761 - 1987-up Toyota harness
- TYTO-01 - 2003-up Toyota JBL amp interface

TOOLS REQUIRED:

- Small Flat Blade Screwdriver/ Panel Removal Tool
- Phillips Screwdriver
- Socket Set
- Magnetized Universal Swivel Head Socket Adapter

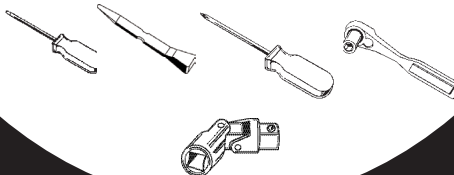

1-800-221-0932



www.metraonline.com

© COPYRIGHT 2010 METRA ELECTRONICS CORPORATION



TABLE OF CONTENTS

Dash Disassembly

- Toyota Venza 2009-2010 1

Kit Assembly

- DIN Head Unit Provision With Pocket2
- ISO Din Head Unit Provision With Pocket 3

***Note:**

Refer also to the instructions included with the aftermarket radio.



KNOWLEDGE IS POWER
Enhance your installation and fabrication skills by enrolling in the most recognized and respected mobile electronics school in our industry. Log onto www.installerinstitute.com or call 800-354-6782 for more information and take steps toward a better tomorrow.



Metra recommends MECP certified technicians.

Toyota Venza 2009-2010

- 1 Disconnect the negative battery terminal to prevent an accidental short circuit.
- 2 Unclip and remove the trim panel to the right of the shifter. (Figure A)
- 3 Remove (1) Phillips screw from the bottom of the climate control then unclip and remove the climate control. (Figure B)
- 4 Remove (4) 10 MM bolts securing the radio. ***Note: You will need a universal swivel head socket adapter to get to the bottom left bolt.*** (Figure C)
- 5 Remove (4) Phillips screws securing the factory radio to the a/c vent panel. (Figure D)

Continue to kit assembly.

A

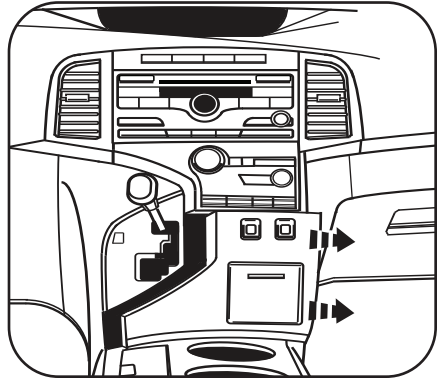

B

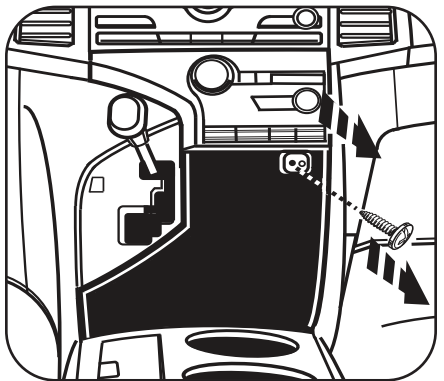

C

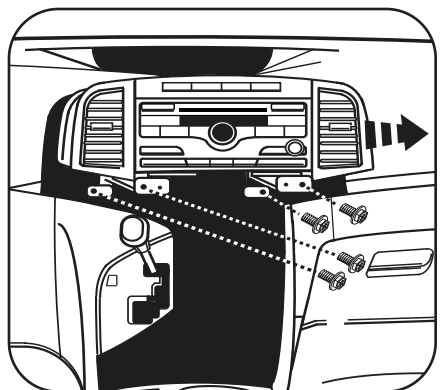

D

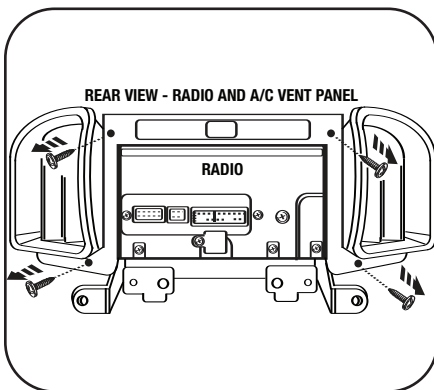

DIN HEAD UNIT PROVISION WITH POCKET

**Note: Refer also to the instructions included with the aftermarket radio.*

- 1 Secure the Radio Housing into the factory a/c vent panel using the factory hardware. (Figure A)
- 2 Locate the factory wiring harness in the dash. Metra recommends using the proper mating adapter from Metra or AXCESS. Re-connect the negative battery terminal and test the unit for proper operation.
- 3 Slide the DIN cage into the Radio Housing and secure by bending the metal locking tabs down. (Figure B)
- 4 Slide the aftermarket head unit into the cage and secure. (Figure C)
- 5 Snap the factory vent panel/Radio Housing over dash cavity. (Figure D)
- 6 Reassemble remaining radio and dash assemblies in reverse order of disassembly.

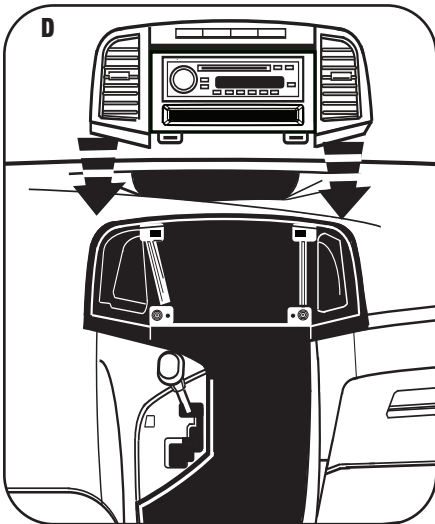
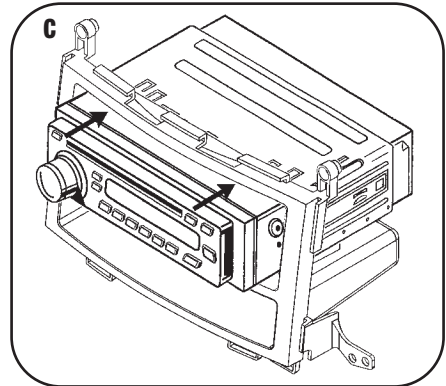
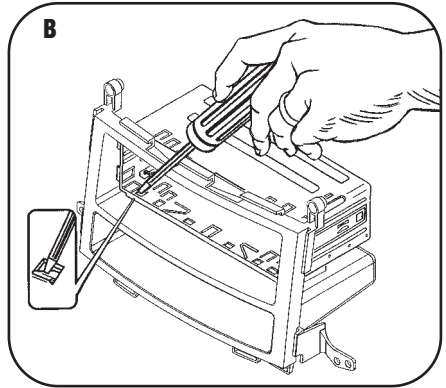
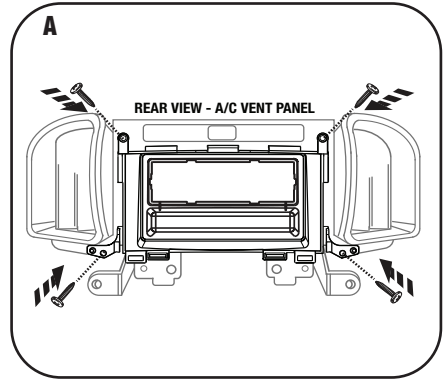

ISO DIN HEAD UNIT PROVISION WITH POCKET

**Note: Refer also to the instructions included with the aftermarket radio.*

- 1 Secure the Radio Housing into the factory a/c vent panel using the factory hardware. (Figure A)
- 2 Mount the ISO Brackets to the head unit with the screws supplied with the unit. (Figure B)
- 3 Slide the head unit into the radio opening until the side clips engage. (Figure C)
- 4 Snap the Trim Plate into the Radio Housing. (Figure C)
- 5 Snap the factory vent panel/Radio Housing over dash cavity. (Figure D)
- 6 Reassemble remaining radio and dash assemblies in reverse order of disassembly.

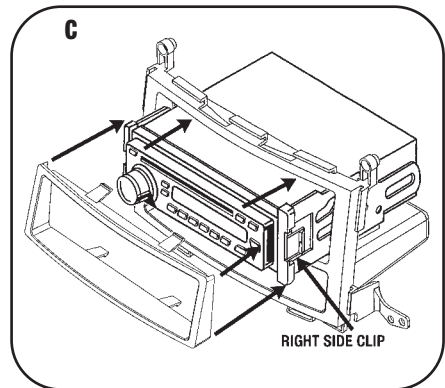
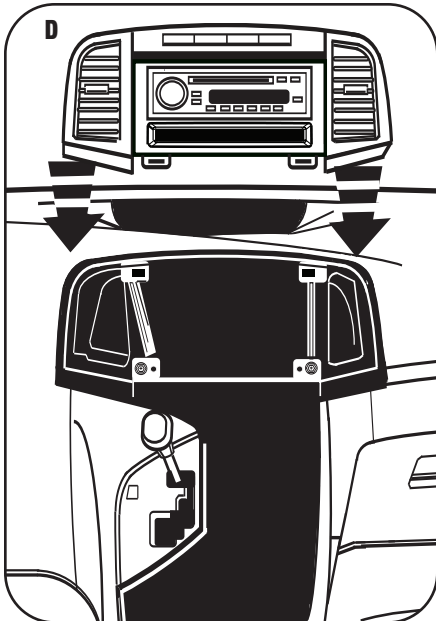
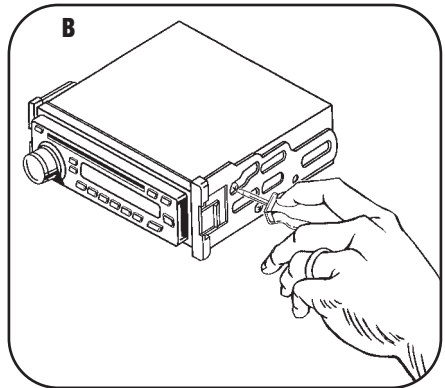
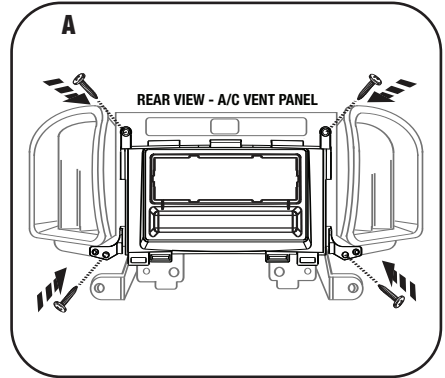

99-8225G INSTRUCTIONS



1-800-221-0932



www.metraonline.com

REV. 05/20/10 © COPYRIGHT 2010 METRA ELECTRONICS CORPORATION INST99-8225G