

# Attachment Illustrated Parts List

## Attachment

**Mfg. No.    Description**

7063281    Twin Bag Catcher, 28" & 33" R.E.R.

### Briggs & Stratton Power Products Group, L.L.C.

P.O. Box 702  
Milwaukee, WI 53201-0702 USA

BRIGGSandSTRATTON.com

© Copyright 2012 by Briggs & Stratton Corporation  
Milwaukee, WI, USA. All rights reserved

**Manual Part No. 7105884**

Revision -

Rev. Date: 7/25/2012

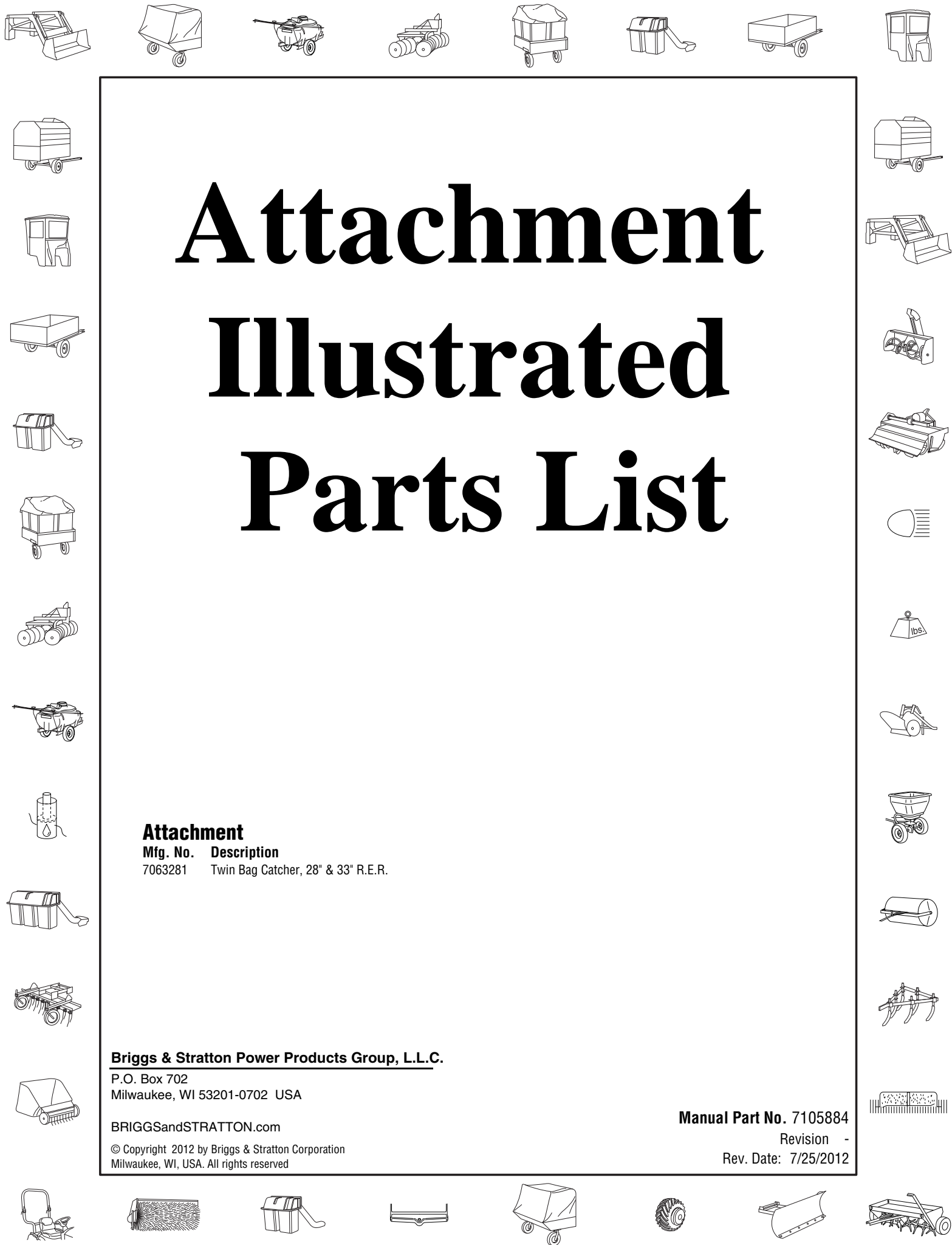

Not for  
Reproduction

<b>PRODUCT COMPONENTS</b>	<b>PAGES</b>
Catcher Group .....	4
Chute Group .....	6
<b>Torque Specification Chart .....</b>	<b>Inside Back Cover</b>

Not for  
Reproduction

# Catcher Group

0061

NOTE: Unless noted otherwise, use the standard hardware torque specification chart.

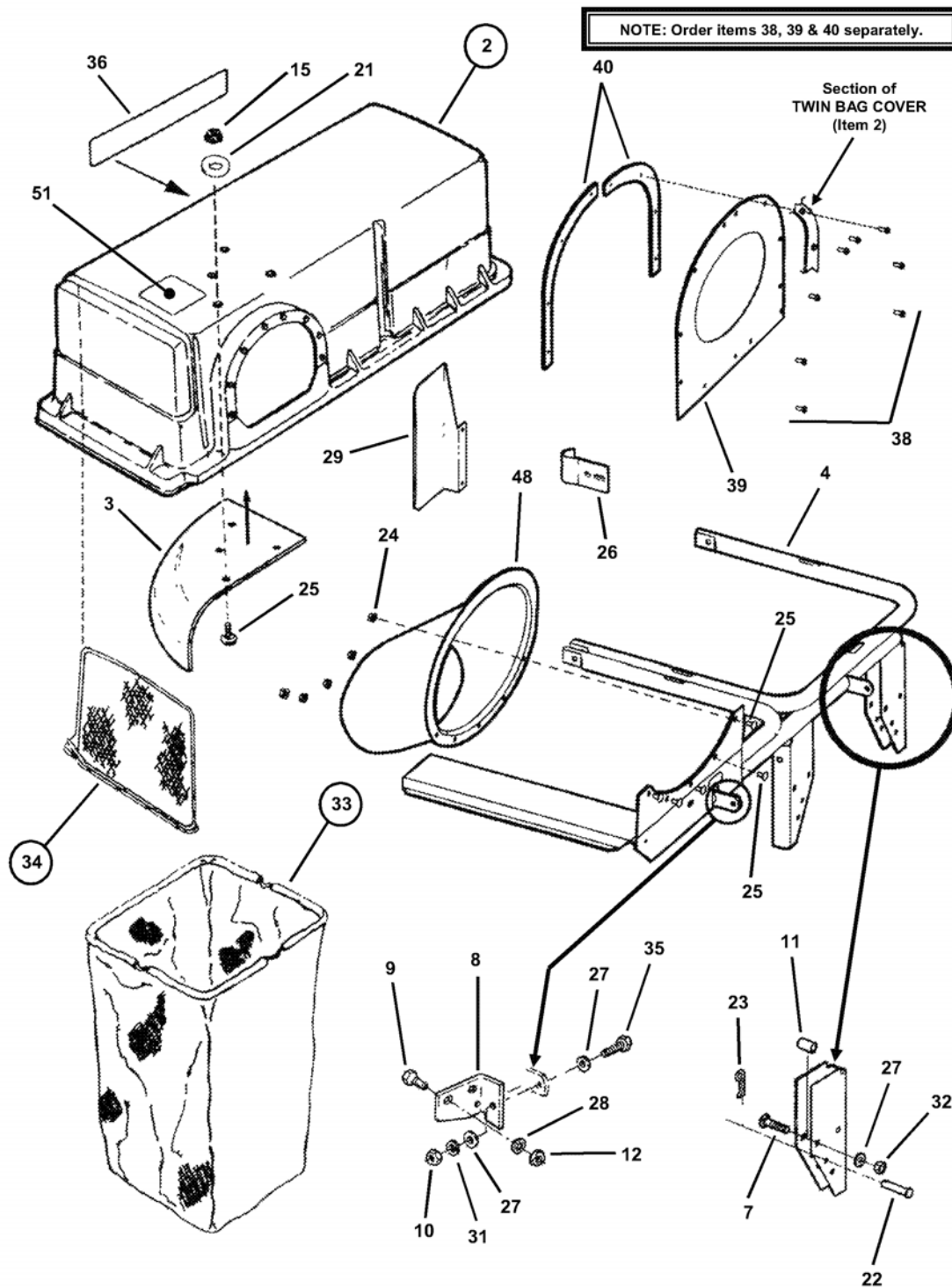

The above parts group applies to the following Mfg. Nos.:

7063281 - Twin Bag Catcher

## Catcher Group

REF NO	PART NO.	QTY.	DESCRIPTION
--	7063281	1	KIT, Grass Catcher Was 60946
2	7059626	1	COVER, Twin Bag
3	7019725	1	SECTOR
4	7059951	1	WELDMENT, Frame
7	7091612	2	BOLT, 5/16-18 x 1-1/2" Carr.
8	7038087	2	HINGE, Top
9	7091611	4	SCREW, 1/4-28 x 3/4" Cap
10	7091606	2	NUT, 5/16-24 Hex Center Lock
11	7023797	2	PAD, Bumper Mount
12	7090095	4	NUT, 1/4-28 Hex Was 91605
15	7091576	8	NUT, 1/4-20 Hex Included in Hardware Bag 60589
21	7091294	4	WASHER, 1/4" Flat Included in Hardware Bag 60589
22	7029841	3	PIN, 5/16 x 11/16" Clevis Included in Hardware Bag 60589
23	7091503	3	PIN, 3/32 x 1-1/2" Hair Included in Hardware Bag 60589
24	7091545	5	NUT, 1/4-20 Flange Lock Included in Hardware Bag 60589
25	7091604	5	BOLT, 1/4-20 x 1/2" Carriage Included in Hardware Bag 60589
26	7031954	1	SUPPORT, Bumper
27	7090188	6	WASHER, 5/16" Flat
28	7090053	4	WASHER, 1/4 Int.Tooth Lock Was 91314
29	7071677	1	GUARD, Muffler
31	7091315	2	WASHER, 5/16 Split Lock
32	7091575	2	NUT, 5/16-18 Hex Center Lock
33	7051930	2	ASS'Y,Bag (Incl. Indented Items)
--	7019250	1	BAG, Grass Catcher
--	7019965	1	ROD, Bag Support
--	7014456	1	CONNECTOR
34	7057652	1	ASS'Y, Screen (Indented Items)
--	7019731	1	SCREEN
--	7019732	1	FRAME, Screen
35	7090238	2	SCREW, 5/16-24 x 1" Cap
36	7019295	1	DECAL, Snapper
38	7090896	8	SCREW, #10-24 x 1/2" S. Tap Was 90853
39	7019794	1	SEAL
40	7038276	2	CLAMP
48	7019966	1	INLET, Twin Bagger
51	7046720	1	DECAL, Chute/Deflector

## Footnotes

The above parts group applies to the following Mfg. Nos.:

7063281 - Twin Bag Catcher

## Chute Group

0063

NOTE: Unless noted otherwise, use the standard hardware torque specification chart.

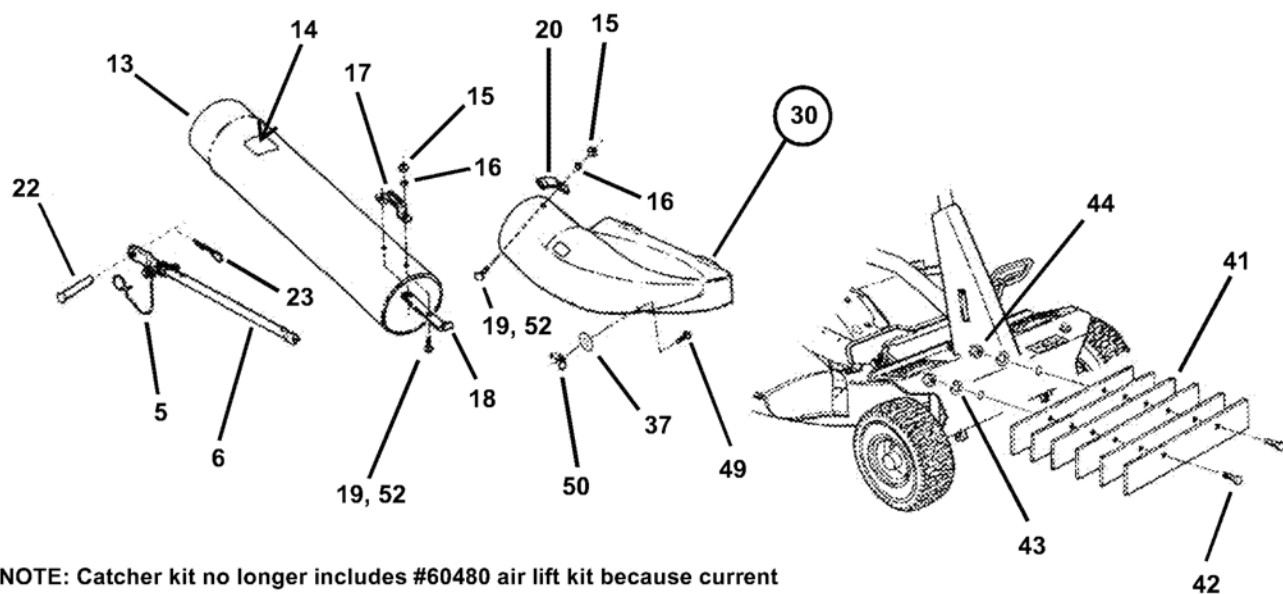

NOTE: Catcher kit no longer includes #60480 air lift kit because current Production blades have no air lift bolt holes.

**SNAPPER**

1-9295

**CAUTION!!!**  
DO NOT USE OR ATTEMPT TO USE THIS KIT WITHOUT FIRST CONSULTING THE SNAPPER KIT USE AND CARE MANUAL WITH ALL PREVIOUS EDITIONS OF THIS MANUAL.

1-1910

**WARNING**  
BLADES OR ENTIRE GRASS CATCHER MUST BE INSTALLED BEFORE OPERATING MOWER.

4-6720

The above parts group applies to the following Mfg. Nos.:

7063281 - Twin Bag Catcher

## Chute Group

REF NO	PART NO.	QTY.	DESCRIPTION
5	7051407	1	ASSEMBLY, Spring & Hook
6	7036073	1	BRACE, Rear (24-1/2" Long)
--	7046573	1	BRACE, Rear (24-13/16" Long)
13	7014517	1	TUBE, Grass (36" long)
14	7011910	1	DECAL, Caution
15	7091576	8	NUT, 1/4-20 Hex Included in Hardware Bag 60589
16	7090053	4	WASHER, 1/4 Internal Tooth Lock Was 91314 (Included in Hardware Bag 60589)
17	7037745	1	HANDLE, Tube Included in Hardware Bag 60589
18	7031952	1	BASE, Tube Handle Included in Hardware Bag 60589
19	7091530	4	BOLT, 1/4-20 x 3/4" Carriage Included in Hardware Bag 60589
20	7031951	1	LATCH, Tube Chute Included in Hardware Bag 60589
22	7029841	3	PIN, 5/16 x 11/16" Clevis Included in Hardware Bag 60589
23	7091503	3	PIN, 3/32 x 1-1/2" Hair Included in Hardware Bag 60589
30	7057809	1	ADAPTER (Includes Decal 4-6720)
37	7090188	6	WASHER, 5/16" Flat Was 91296
41	7072416	6	WEIGHT, Front Frame
42	7091976	2	SCREW, 5/8-11 x 1-3/4" Cap
43	7090333	2	WASHER, 5/8" Split Lock
44	7090537	2	NUT, 5/8-11 Hex
49	7091303	1	BOLT, 5/16-18 x 1" Carriage Included in Hardware Bag 60589
50	7091537	1	WING NUT, 5/16-18 Lock Included in Hardware Bag 60589
52	7091614	4	SCREW, 1/4-20 x 3/4"
1-9295	7019295	1	DECAL, SNAPPER
1-1910	7011910	1	DECAL, GRASS CATCHER
4-6720	7046720	1	DECAL, CHUTE DEFLECTOR

## Footnotes

The above parts group applies to the following Mfg. Nos.:

7063281 - Twin Bag Catcher

Not for  
Reproduction



Not for  
Reproduction

Not for  
Reproduction

# Hardware Identification & Torque Specifications

Torque Specification Chart								
FOR STANDARD METRIC MACHINE HARDWARE (Tolerance ± 20%)								
Property Class	5.6		8.8		10.9		12.9	
	Class 5.6		Class 8.8		Class 10.9		Class 12.9	
Size Of Hardware	in/lbs		in/lbs		in/lbs		in/lbs	
	ft/lbs	Nm.	ft/lbs	Nm.	ft/lbs	Nm.	ft/lbs	Nm.
M3	5.88	.56	13.44	1.28	19.2	1.80	22.92	2.15
M4	13.44	1.28	30.72	2.90	43.44	4.10	52.56	4.95
M5	26.4	2.50	60.96	5.75	5.97	8.10	7.15	9.7
M6	44.64	4.3	7.3	9.9	10.3	14	12.1	16.5
M7	5.2	7.1	12.1	16.5	16.9	23	19.9	27
M8	7.7	10.5	17.7	24	25	34	29	40
M10	15	21	35	48	50	67	59	81
M12	26	36	61	83	86.2	117	103	140
M14	42	58	101	132	136	185	162	220
M16	64	88	147	200	210	285	250	340
M18	89	121	202	275	287	390	346	470
M20	126	171	290	390	405	550	486	660
M22	169	230	390	530	559	745	656	890
M24	217	295	497	375	708	960	840	1140
M27	320	435	733	995	1032	1400	1239	1680
M30	435	590	995	1350	1401	1900	1681	2280
M33	590	800	1349	1830	1902	2580	2278	3090
M36	759	1030	1740	2360	2441	3310	2935	3980
M39	988	1340	2249	3050	3163	4290	3798	5150

The guides and ruler furnished below are designed to help you select the appropriate hardware.



**Nut, M8**

Thread Diameter (mm)  
Inside Diameter (in)  
Threads per inch

**Nut, 1/2-16**

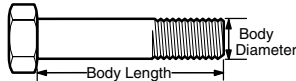

**Screw, M8 - 1.25 x 25**

Thread Diameter (mm)  
Body Diameter  
Distance between threads (mm)  
Threads per inch  
Body Length (mm)  
Body Length (in)

**Screw, 1/2 - 16 x 2**

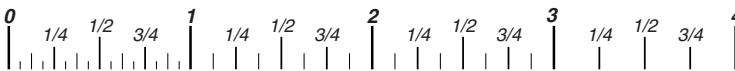

## Standard Hardware Sizing

When a washer or nut is identified as **1/2"** (M8), this is the *Nominal size*, meaning the *inside diameter* is 1/2 inch (8mm metric thread diameter); if a second number is present it represents the *threads per inch* (distance between threads).

When bolt or capscrew is identified as **1/2 - 16 x 2"** (M8 - 1.25 x 50), this means the *Nominal size*, or body diameter is 1/2 inch (8mm metric thread diameter), the second number, 16, represents the *threads per inch*, (*1.25 thread diameter*). The final number is the body length of the bolt or screw, 2 inches (50mm).

Torque Specification Chart						
FOR STANDARD MACHINE HARDWARE (Tolerance ± 20%)						
Hardware Grade	No Marks		SAE Grade 5		SAE Grade 8	
	SAE Grade 2		SAE Grade 5		SAE Grade 8	
Size Of Hardware	in/lbs		in/lbs		in/lbs	
	ft/lbs	Nm.	ft/lbs	Nm.	ft/lbs	Nm.
8-32	19	2.1	30	3.4	41	4.6
8-36	20	2.3	31	3.5	43	4.9
10-24	27	3.1	43	4.9	60	6.8
10-32	31	3.5	49	5.5	68	7.7
1/4-20	66	7.6	8	10.9	12	16.3
1/4-28	76	8.6	10	13.6	14	19.0
5/16-18	11	15.0	17	23.1	25	34.0
5/16-24	12	16.3	19	25.8	29	34.0
3/8-16	20	27.2	30	40.8	45	61.2
3/8-24	23	31.3	35	47.6	50	68.0
7/16-14	30	40.8	50	68.0	70	95.2
7/16-20	35	47.6	55	74.8	80	108.8
1/2-13	50	68.0	75	102.0	110	149.6
1/2-20	55	74.8	90	122.4	120	163.2
9/16-12	65	88.4	110	149.6	150	204.0
9/16-18	75	102.0	120	163.2	170	231.2
5/8-11	90	122.4	150	204.0	220	299.2
5/8-18	100	136	180	244.8	240	326.4
3/4-10	160	217.6	260	353.6	386	525.0
3/4-16	180	244.8	300	408.0	420	571.2
7/8-9	140	190.4	400	544.0	600	816.0
7/8-14	155	210.8	440	598.4	660	897.6
1-8	220	299.2	580	788.8	900	1,244.0
1-12	240	326.4	640	870.4	1,000	1,360.0

## NOTES

- These torque values are to be used for all hardware excluding: locknuts, self-tapping screws, thread forming screws, sheet metal screws and socket head setscrews.
- Recommended seating torque values for locknuts:
  - for prevailing torque locknuts - use 65% of grade 5 torques.
  - for flange whizlock nuts and screws - use 135% of grade 5 torques.
- Unless otherwise noted on assembly drawings, all torque values must meet this specification.

## Common Hardware Types

Hex Head Capscrew



Washer

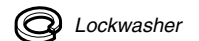

Lockwasher

Carriage Bolt



Hex Nut

## Wrench & Fastener Size Guide

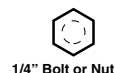

1/4" Bolt or Nut  
Wrench—7/16"



5/16" Bolt or Nut  
Wrench—1/2"



3/8" Bolt or Nut  
Wrench—9/16"



7/16" Bolt or Nut  
Wrench (Bolt)—5/8"  
Wrench (Nut)—11/16"



1/2" Bolt or Nut  
Wrench—3/4"

M6 Bolt or Nut  
Wrench—10mm

M8 Bolt or Nut  
Wrench—13mm

M10 Bolt or Nut  
Wrench—17mm

M12 Bolt or Nut  
Wrench—19mm

M14 Bolt or Nut  
Wrench—22mm

Not for  
Reproduction

**IT IS THE POLICY OF BRIGGS & STRATTON CORP TO IMPROVE ITS PRODUCTS  
WHENEVER IT IS POSSIBLE AND PRACTICAL TO DO SO. WE RESERVE THE RIGHT TO  
MAKE CHANGES OR ADD IMPROVEMENTS AT ANY TIME WITHOUT INCURRING ANY  
OBLIGATION TO MAKE SUCH CHANGES ON PRODUCTS.**

**Briggs & Stratton Power Products Group, L.L.C.**

P.O. Box 702  
Milwaukee, WI 53201-0702 USA

BRIGGSandSTRATTON.com	Murray.com
Snapper.com	AllisChalmersLawn.com
SimplicityMFG.com	AGCOLawn.com
MasseyLawn.com	