

# **BODYCRAFT**

## **INSTRUCTION MANUAL LEG PRESS OPTION OF GX GYM (BCG-GX)**

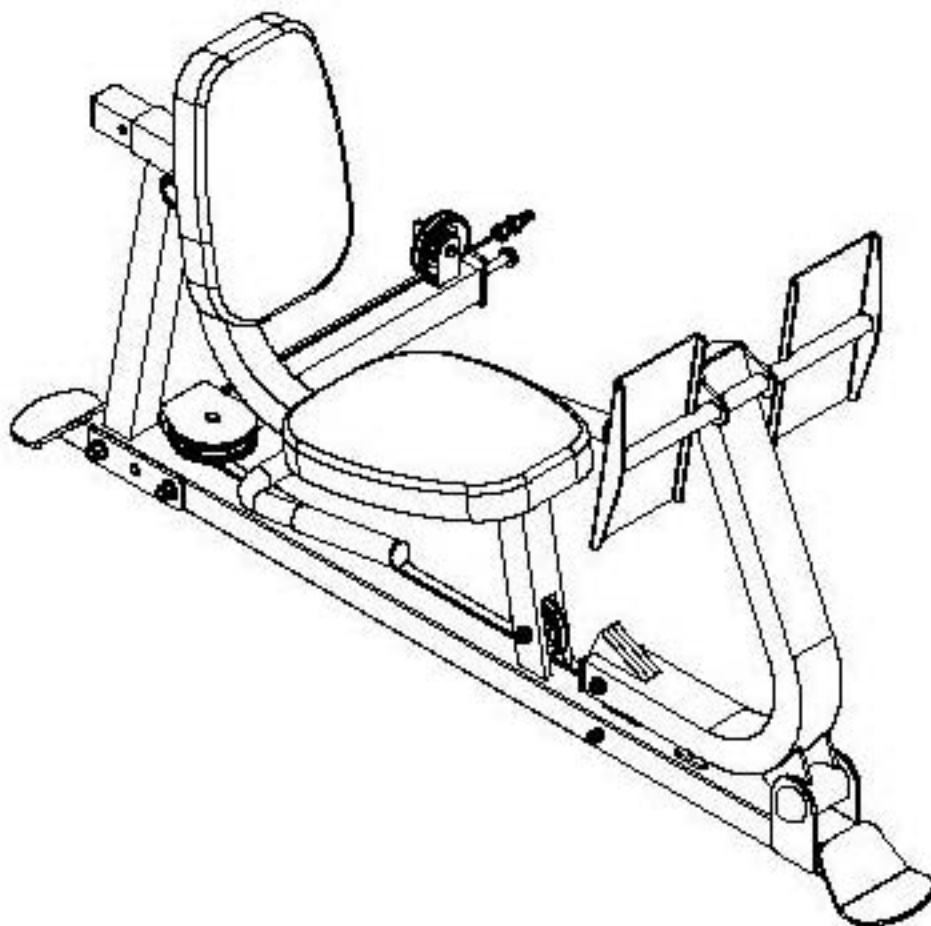

### **Questions?**

*As a quality home gym supplier we are committed to your complete satisfaction. If you have questions or find missing or damaged parts, we will guarantee your complete satisfaction through our authorized dealer service centers or our home office customer service department. Please call your local dealer for assistance or BODYCRAFT at 800-990-3336 (9:00 AM - 5:00 PM). Our trained technicians will provide immediate assistance to you, free of charge.*

*We stand behind our products. Every piece, every part of this BODYCRAFT strength training system is guaranteed for as long as you own it. We will repair or replace anything that goes wrong.*

*Bodycraft is a division of Recreation Supply Inc.  
P. O. Box 181  
Sunbury, OH 43078*

**MZ6882**

## **BEFORE YOU BEGIN**

Congratulations and thank you for selecting the **BODYCRAFT GX GYM LEG PRESS** strength training system. The **BODYCRAFT GX GYM LEG PRESS** offers an impressive array of strength training exercises to develop every major muscle group of the body.

Whether your goal is cardiovascular fitness, a shapely, toned body or dramatic muscle size and strength, the **BODYCRAFT GX GYM LEG PRESS** will help you achieve the specific results you want.

**For your safety and benefit, read this manual and the accompanying literature before using the BODYCRAFT GX GYM LEG PRESS.** Keep this manual for future reference. If you have additional questions, please call your local **BODYCRAFT** dealer or our customer service department at 800-990-5556 Monday through Friday, 9 a.m. until 5 p.m. Eastern Time.

## **IMPORTANT SAFETY NOTES**

**There is a risk assumed by individuals who use this type of equipment. Before beginning this or any other exercise program consult your physician. This is especially important for individuals over the age of 35 or persons with pre-existing health problems. Recreation Supply, Inc. assumes no responsibility for personal injury or property damage sustained by or through use of this product.**

1. This product must be assembled on a flat, level surface to assure its proper function.
2. Clean pads and frame on a regular basis. We recommend warm, soapy water. Do not use harsh or abrasive chemicals.
3. Inspect and tighten all parts before every use. Replace any worn parts immediately. Failure to do so may result in serious injury.
4. Keep children away from the **BODYCRAFT GX GYM LEG PRESS** at all times.
5. Keep your hands away from cables and pulleys during operation. Keep your hands away from moving parts other than the designated handles.
6. Make certain all cables are seated within the pulleys before every use.
7. Exercise with care to avoid injury.
8. If unsure about the proper use of the **BODYCRAFT GX GYM LEG PRESS** strength training system call your local **BODYCRAFT** dealer or our customer service department at 800-990-5556.

EXPLODED

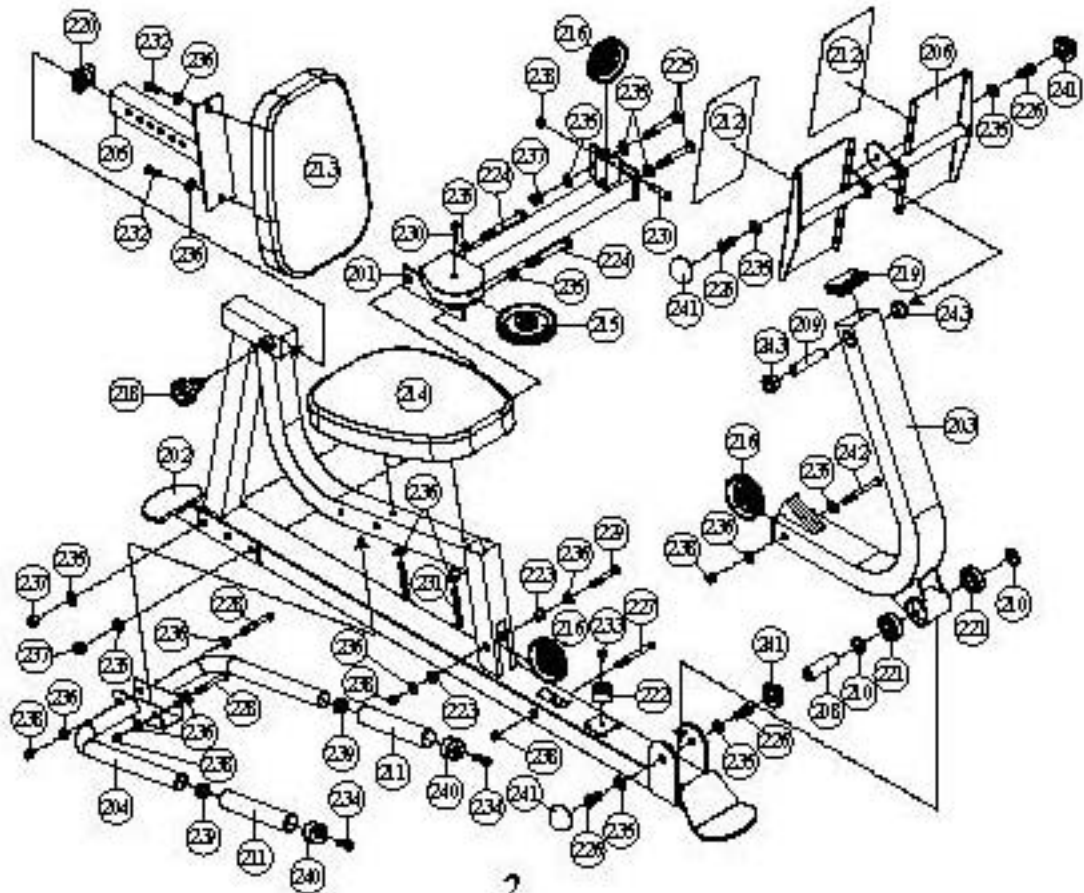
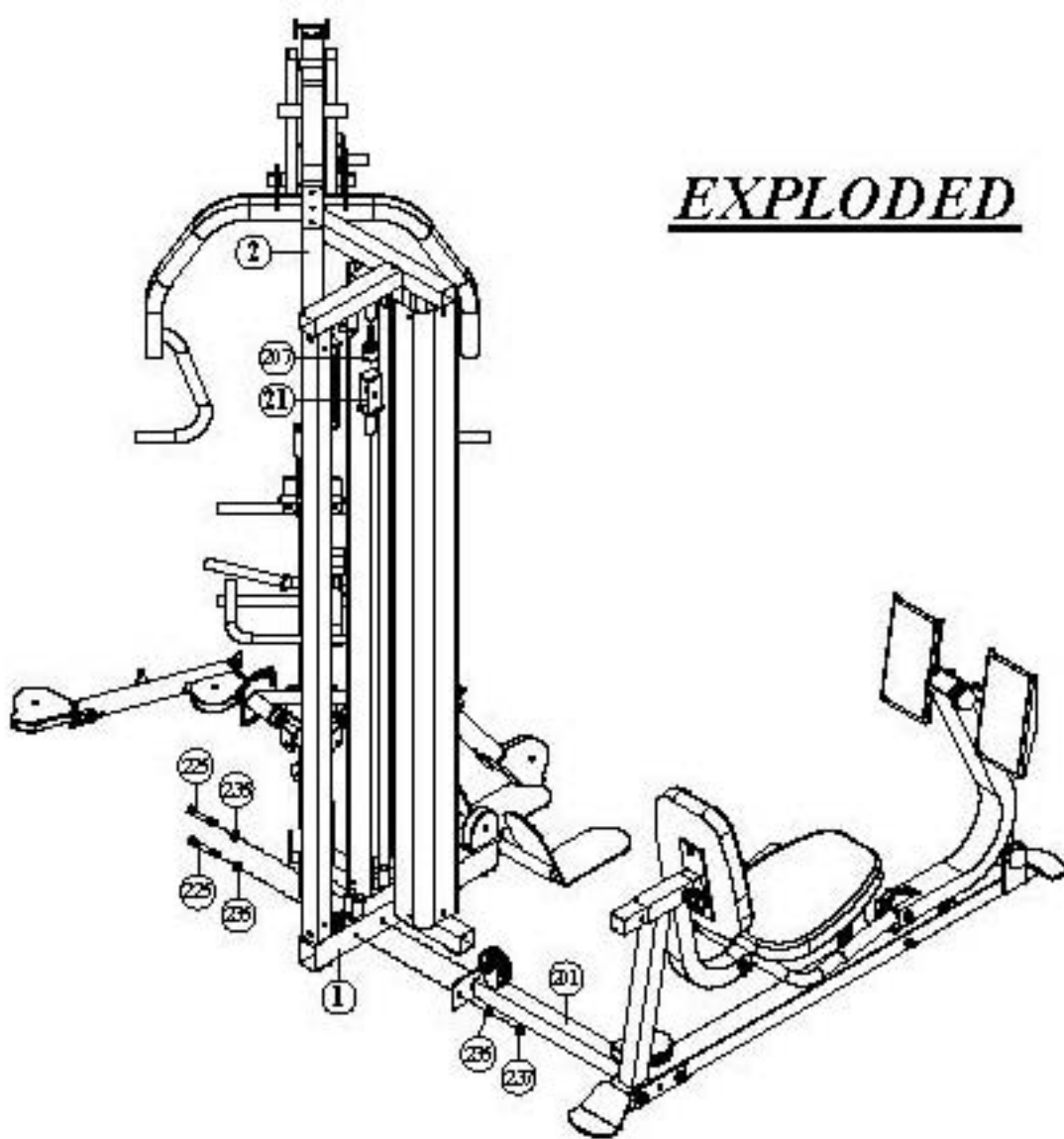

# PARTS LIST

NO.	DESCRIPTION	QTY.
201	BASE STABILIZER	1
202	MAIN FRAME	1
203	LEG PRESS SUPPORT	1
204	SEAT HANDLE	1
205	BACK PAD ADJUSTER	1
206	FOOT PLATE	1
207	RUBBER STOPPER	1
208	∅ 25mm AXLE	1
209	∅ 3/4" AXLE	1
210	COLLAR	2
211	1-1/4" X 360mm HAND GRIP (pre-assembled)	2
212	NON SLIP	2
213	BACK PAD	1
214	SEAT PAD	1
215	114mm PULLEY	1
216	90mm PULLEY	3
217	LEG PRESS CABLE	1
218	LOCKING SPRING KNOB	1
219	50 X 75mm RECT. PLUG	1
220	45mm SQ. PLUG	1
221	BEARING	2
222	LEG PRESS STOPPER	1
223	LEG PRESS BUSHING	2
224	1/2" X 4-1/4" HEX BOLT	2
225	1/2" X 3-1/4" HEX BOLT	2
226	1/2" X 1" HEX THREADED BOLT	4
227	3/8" X 4" HEX BOLT	1
228	3/8" X 3-1/8" HEX BOLT	2
229	3/8" X 3" HEX BOLT	1
230	3/8" X 1-3/4" HEX BOLT	2
231	3/8" X 2-3/4" HEX THREADED BOLT	2
232	3/8" X 1" HEX THREADED BOLT	2
233	3/8" X 5/8" SET SCREW (pre-assembled)	1
234	5/16" X 1-1/4" HEX THREADED BOLT	2
235	1/2" WASHER	11
236	3/8" WASHER	12
237	1/2" NYLON NUT	2
238	3/8" NYLON NUT	6
239	5/16" NUT (pre-assembled)	2
240	SEAT PAD SUPPORT STOPPER	2
241	CAP FOR NUT	4
242	3/8" X 3-1/2" HEX BOLT	1
243	3/4" BUSHING	2

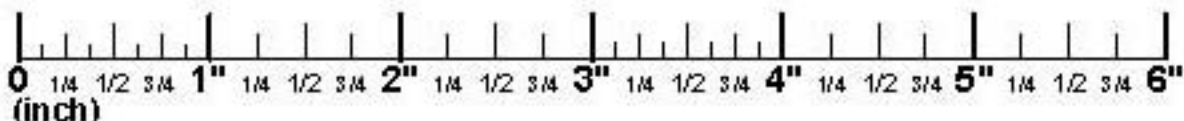
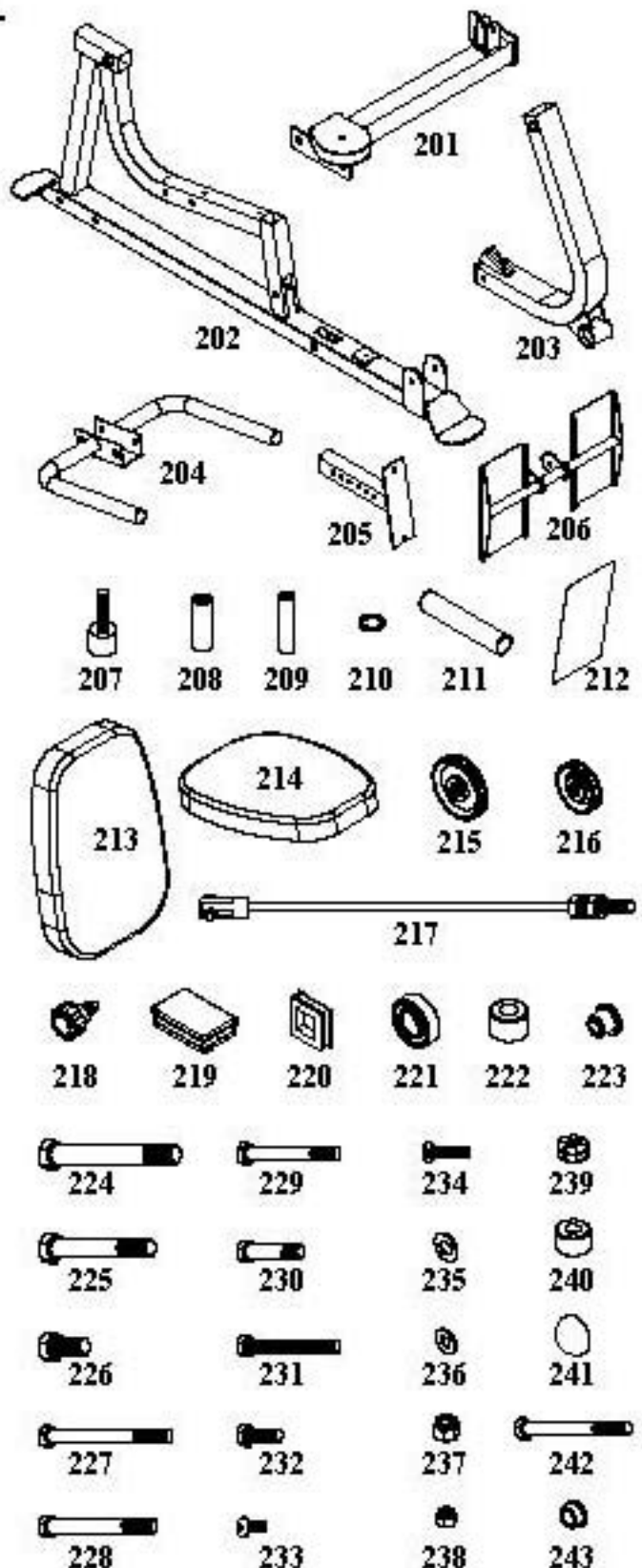

## STEP 1 ASSEMBLE BASE FRAME

**To ease assembly , Do Not tighten any bolts until instructed.**

1. Attach the Base Stabilizer (201) to the Base Frame (1), using two 1/2" X 3-1/4" Hex Bolts (225), three 1/2" Washers (235) and one 1/2" Nylon Nut (237).

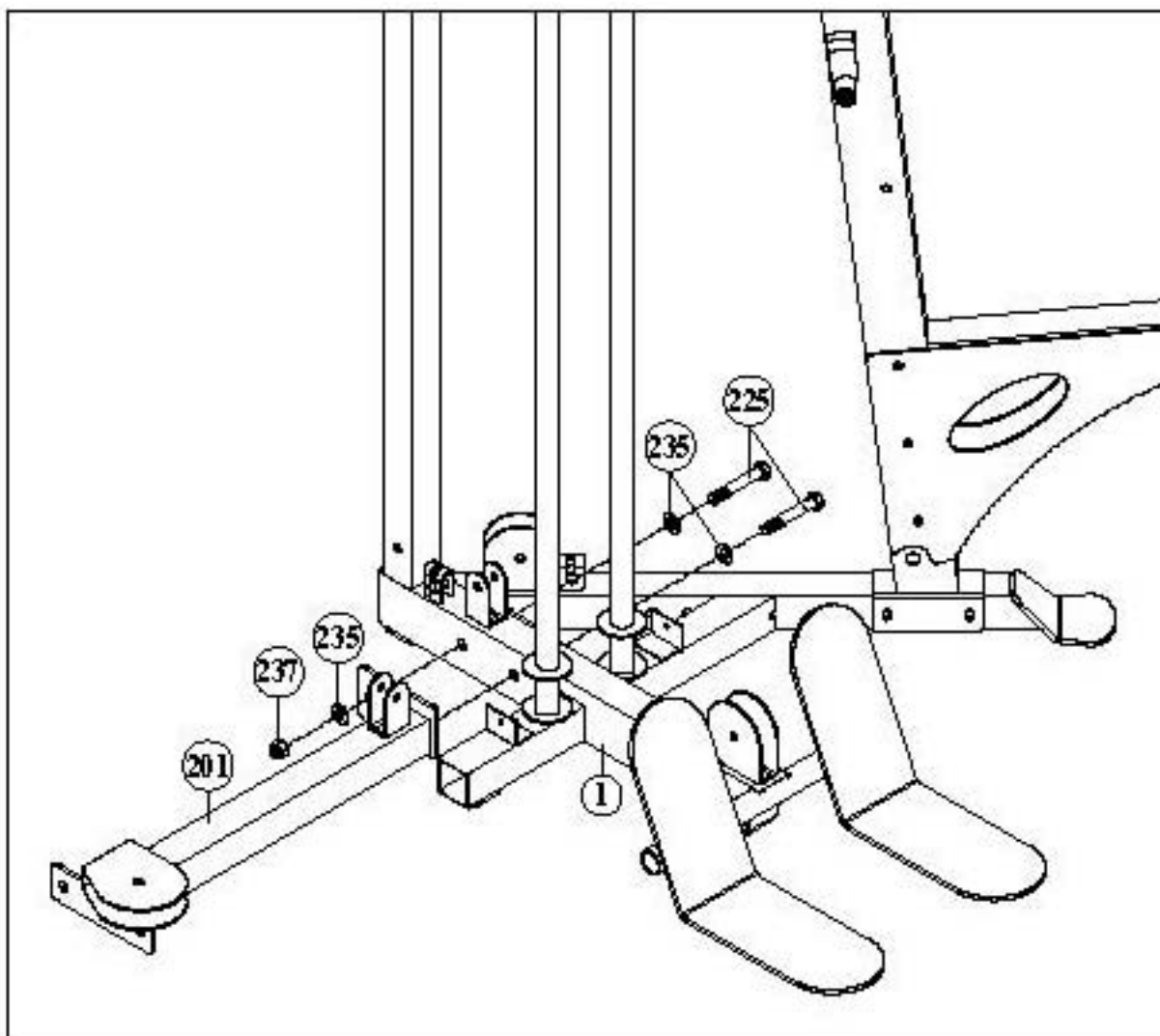

## STEP 2 ASSEMBLE MAIN FRAME

1. Attach the Main Frame (202) to The Base Stabilizer (201), using two 1/2" X 4-1/4" Hex Bolts (224), four 1/2" Washers (235) and two 1/2" Nylon Nuts (237).
2. Insert the 25mm Axle (208) into the Leg Press Support (203), then attach to the Main Frame (202) using two Collars (210) {inside the brackets on the Main Frame (202)}, two 1/2" X 1" Hex Threaded Bolts (228), and two 1/2" Washers (235). Tighten the bolts and then cap with two End Caps (241).
3. Insert the 3/4" Axle (209) into the top hole in the Leg Press Support (203), then attach the Foot Plate (206) using two 1/2" X 1" Hex Threaded Bolts (226), and two 1/2" Washers (235). Tighten the bolts and then cap with two End Caps (241).
4. Attach Seat Handle (204) to the Main Frame (202), using two 3/8" X 3-1/8" Hex Bolts (228), four 3/8" Washers (236) and two 3/8" Nuts (238).
5. Attach Seat Pad (214) to the Main Frame (202), using two 3/8" X 2-3/4" Hex Threaded Bolts (231) and two 3/8" Washers (236).
6. Attach Back Pad (213) into the Back Pad Adjuster (205), using two 3/8" X 1" Hex Threaded Bolts (232) and two 3/8" Washers (236). Then slide the Back Pad Adjuster (205) to the Main Frame (202) and lock at your desired position using the Spring Knob (218) and lock (219).

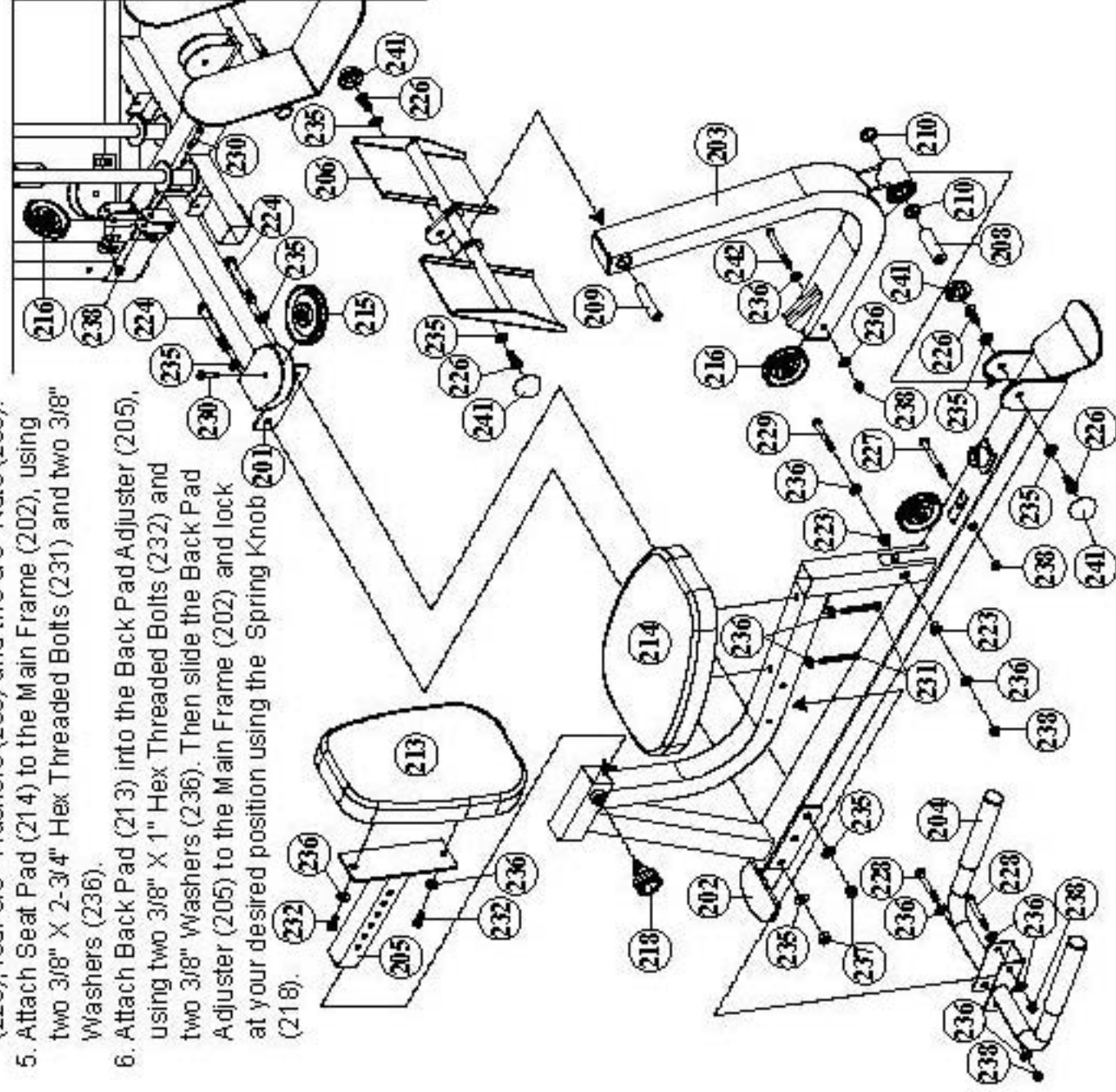

## STEP 3 ASSEMBLE LEG PRESS CABLE

### *Assemble cables and pulleys simultaneously.*

1. Locate the Floating Pulley Block (21) assembled to the base unit of the GX. Unscrew the Floating Pulley Block (21). Screw the Rubber Stopper (207) into the Top Frame (2) in place of the Floating Pulley Block (21). Flip the Floating Pulley Block (21) over (you will need to remove the pulley when doing this) so that the flat end of Floating Pulley Block (21) is resting against the Rubber Stopper (207) as shown in Fig. 1.
2. Screw the threaded end of the Leg Press Cable (217) about half way into the threaded receptacle in the Floating Pulley Block (21). This is an adjustment area where the cable can be tightened or loosened. Be certain to always have at least one third of the threaded end of the cable screwed into the Floating Pulley Block (21). Also be certain to tighten the locking nut securely to prevent the cable from unscrewing.
3. Route the flat end of the cable down and under the vertical pulley (216) mounted to the Base Stabilizer (201) using one 3/8" X 1-3/4" Hex Bolt (230) and one 3/8" Nylon Nut (238) as shown in Fig. 2.
4. Continue routing the cable over to the horizontal Pulley (216) mounted to the Base Stabilizer (201) using one 3/8" X 1-3/4" Hex Bolt (230) as shown in Fig. 3.
5. Route the cable under a pulley mounted under the seat using two Leg Press Bushings (223), one 3/8" X 3" Hex Bolt (229), two 3/8" Washers (236), and one 3/8" Nylon Nut (238) as shown in Fig. 4.
6. Continue routing over top of a pulley mounted in the end of the Leg Press Support (203) using two Leg Press Bushings (223), one 3/8" X 3" Hex Bolt (229), two 3/8" Washers (236), and one 3/8" Nylon Nut (238) as shown in Fig. 5.
7. Attach the flat end of the cable to the base of the Leg Press Support (203) using one 3/8" X 4" Hex Bolt (227) and one 3/8" Nylon Nut (238).





**Assembly is complete! Please take the following steps before using the gym:**

1. Make certain all bolts are tightened securely.
2. Make certain all cables are seated into all pulley grooves. A cable rubbing-against steel will peel the nylon coating, voiding warranty and resulting in a need for replacement.
3. Pre-stretch the cables. Pull on the cables with great force, helping remove any links and providing any initial cable stretch.
4. Be aware the cables can loosen and slightly stretch upon initial use.
5. For better performance, apply a household lubricant (such as silicone) to any adjustable areas.
6. Enjoy many years of a Fit Lifestyle.

**Thank you for purchasing the BodyCraft GX GYM LEG PRESS. If You have any questions, please call your local BodyCraft dealer or call our customer service department at 800-990-5556**