

**INSTRUCTIONS FOR THE USE & CARE
OF YOUR ZANUSSI FRIDGE/FREEZER
DF67/42FF**



**ZANUSSI
USE & CARE
MANUAL**



It is most important that this instruction book should be retained with the appliance for future reference. Should the appliance be sold or transferred to another owner, or should you move house and leave the appliance, always ensure that the book is supplied with the appliance in order that the new owner can get to know the appliance.

Warnings and Guidance

These warnings are provided in the interest of safety. You must read them carefully before installing or using the appliance.

- This appliance is designed to be operated by adults. Children should not be allowed to tamper with the controls or play with the product.
- Any electrical work required to install this appliance should be carried out by a qualified electrician.
- This product should be serviced by an authorised Zanussi Service Force Centre, and only genuine Zanussi spare parts should be used.
- It is dangerous to alter the specifications or modify this product in any way.
- Care must be taken to ensure that the appliance does not stand on the electrical supply cable.
- Zanussi domestic refrigerators and fridge/freezers are designed to be used specifically for the storage of edible foodstuffs only.
- Frozen food must not be re-frozen once it has been thawed out.
- Manufacturer's storage recommendations should be strictly adhered to. Refer to relevant instructions.
- There are working parts in this product which heat up. Always ensure that there is adequate ventilation as a failure to do this will result in component failure and possible food loss. See Installation instructions.
- Parts which heat up should not be exposed. Wherever possible the back of the appliance should be against a wall.
- Before cleaning or maintenance work is carried out, be sure to switch off the appliance and unplug.
- The inner lining of the appliance consists of channels through which the refrigerant passes. If this should be punctured this would damage the appliance beyond repair and cause food loss.
- The appliance should be left for 2 hours after installation before it is turned on in order to allow the refrigerant to settle.
- Do not place carbonated or fizzy drinks in the freezer as it creates pressure on the container which may cause it to explode, resulting in damage to the appliance.
- Ice lollies can cause frost burns if consumed straight from the freezer.
- Under no circumstances should you attempt to repair the appliance yourself. Repairs carried out by inexperienced persons may cause injury or more serious malfunctioning. Refer to your local Zanussi Service Force Centre, and always insist on genuine Zanussi spare parts.

CONTENTS

| | |
|--|----------------|
| Conservation | Page 4 |
| General Features | Page 5 |
| Electrical Connections | Page 6 |
| Installation | Page 7 |
| Starting Up | Page 8 |
| Using Your Fridge/Freezer | Page 9 |
| Freezing Fresh Food | Page 11 |
| Looking After Your Fridge/Freezer | Page 12 |
| Health and Safety Guidelines | Page 14 |
| What Happens If Something Goes Wrong? | Page 15 |
| Servicing | Page 16 |
| Service Force Directory | Page 17 |
| Peace Of Mind For Twelve Months | Page 21 |
| Or Five Years | Page 22 |

CONSERVATION

In the interests of the Environment:

When disposing of your old fridge, freezer or fridge/freezer.

Check with your local Council or Environmental Health Officer to see if there are facilities in your area for collecting the gas in the appliance for re-cycling. This will help the amount of CFC gas in the atmosphere.

Help to keep your countryside tidy - use authorised disposal sites for your old appliances.

For Maximum Efficiency:

Make sure that the appliance is cleaned regularly.

Make sure that the door is closed properly.

Do not position the appliance near to sources of heat.

Do not over-fill your appliance, air **MUST** be allowed to circulate.

GENERAL FEATURES

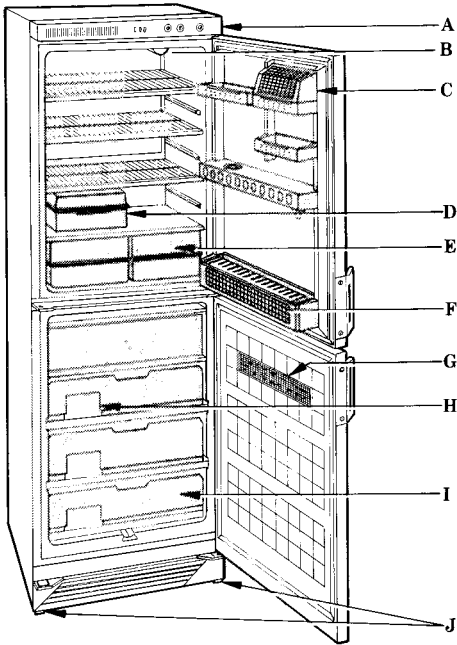

- A. Control Panel
- B. Interior Light
- C. Dairy Compartment
- D. Meatbox
- E. Salad Crispers
- F. Storage Shelf with Bottle Grippers
- G. Produce Storage Guide
- H. Produce Storage Card
- I. 4 Star Freezer Compartment
- J. Adjustable Feet

Dimensions

| | |
|--------|--------|
| Height | 1800mm |
| Width | 595mm |
| Depth | 595mm |
| Weight | .76 kg |

Capacity

| | | |
|--------|---------|-----------|
| Gross: | Fridge | 6.7 cu ft |
| | Freezer | 4.1 cu ft |
| Net: | Fridge | 6.5 cu ft |
| | Freezer | 3.5 cu ft |

| | |
|----------------------|--------------------|
| Star Rating | 4 |
| Power Absorbed | 210W |
| Voltage | 220/240V |
| Frequency | 50Hz average daily |
| Units of Electricity | 1.9 KWH |

THE ELECTRICAL CONNECTIONS

WARNING: THIS APPLIANCE MUST BE EARTHED.

The manufacturer declines any liability should this safety measure not be observed.

If the plug that is fitted to your appliance is not suitable for your socket outlet, it must be cut off and the appropriate plug fitted.

The cut off plug should be disposed of to prevent the hazard of electric shocks in case it should be plugged into a 13amp socket in another part of your home.

Important

The wires in this mains lead are coloured in accordance with the following code:

| | |
|------------------|-----------|
| Green and Yellow | - Earth |
| Blue | - Neutral |
| Brown | - Live |

If you fit your own plug the colours of the wires in the mains lead of your appliance may not correspond with the markings identifying the terminal in your plug, proceed as follows:

Connect the green and yellow (earth) wire to the terminal in the plug which is marked with the letter 'E' or the earth symbol  or coloured green and yellow.

Connect the blue (neutral) wire to the terminal in the plug which is marked with the letter 'N' or coloured black.

Connect the brown (live) wire to the terminal in the plug which is marked with the letter 'L' or coloured red.

The plug moulded onto the cord incorporates a fuse. For replacement, use a 13amp BS1362 fuse. Only ASTA approved fuses should be used.

The fuse cover/carrier must be replaced in the event of changing a fuse. The fuse cover/carrier colour is the one shown by a coloured insert at the base of the plug.

The plug must not be used if the fuse cover/carrier is lost. A replacement cover/carrier can be obtained from your local Zanussi Service Force Agents whose address is listed on pages toward the back of this instruction book.

This appliance complies with E.E.C. Directive no. 82/499 of 7.6.82 relative to radio interference suppression.

INSTALLATION

WARNING:

IF YOU ARE DISCARDING AN OLD APPLIANCE THAT HAS A LOCK OR CATCH ON THE DOOR, PLEASE ENSURE THAT THIS IS MADE UNUSABLE TO PREVENT YOUNG CHILDREN BEING TRAPPED INSIDE.

To support the doors during transit, a plastic packing piece is fitted to the lower hinge of the freezer door. This packing piece should be removed after opening the door, and kept for re-use should the appliance be removed at a future date (fig 1).

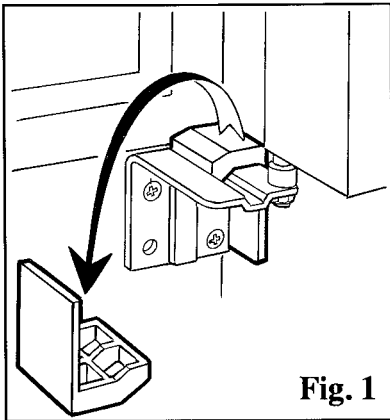

Fig. 1

For this appliance to work efficiently, it should be located away from heat sources, e.g. cookers, radiators, direct sunlight etc. This also includes locations or rooms where the ambient temperature reaches above 32°C, or drops to below 16°C e.g. conservatories.

You should ensure that air can circulate freely around the back and the top of the cabinet. There must be at least 75mm (3") distance between the top of the cabinet and any overhanging furniture. There should also be a gap of 25mm either side of the appliances. DO NOT install in places of restricted ventilation.

Level the appliance by adjusting the two adjustable feet underneath the front of the cabinet, using your fingers or a spanner.

STARTING UP

Remove all securing tapes. Wash the inside of the appliance with lukewarm water and a little bicarbonate of soda (one teaspoonful to 1.2 litres/2 pints of water). Do not use soap or detergent as the smell might linger. Dry thoroughly.

To start the cooling system, insert the plug into the wall socket. Switch the wall socket on. The green operating light will illuminate. Turn the freezer thermostat control to numbers 3-4 with the help of a coin. This setting will ensure that a suitable temperature will be obtained (-18°C or below) for the storage of frozen food under most conditions.

In cold weather, the control may be turned to a lower number but it must be returned to a higher setting when the conditions return to normal. By turning the control to '●' the freezer section alone is turned off.

Please note that the internal temperature will also be affected by the location, room temperature the amount of food being stored and the number of times which the door is opened.

To start the refrigerator section, turn the refrigerator thermostat control to numbers 3-4 with the help of a coin. This setting will ensure that suitable temperatures will be obtained for the storage of fresh food under most conditions (3-7°C). If more cooling is required, especially in hot weather or when the cabinet is full, the control can be turned to a higher number. If less cooling is required, in the winter for instance, the control should be turned to a lower number. Remember to turn the control back to its usual position when conditions return to normal.

By turning the control to '●' position the refrigerator section alone is turned off.

Please note that the internal temperature will be affected by the location, room temperature, the amount of food being stored and the number of times which the door is opened.

The appliance should be allowed to run for 24 hours before the food is stored in it.

USING YOUR FRIDGE/FREEZER

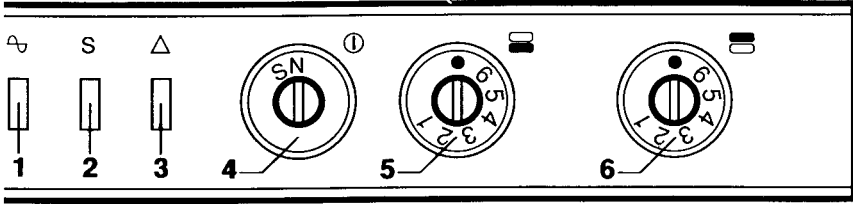

The Control Panel

1) Main on Light (green):

Lights up continuously when the appliance is operating.

2) Fast Freeze Indicator Light (orange):

Lights up when the fast freeze operation is activated.

3) Warning Light (red):

Indicates that the temperature in the freezer has risen. This can light up if the door has been left open for a period of time or a large amount of food has been placed in the freezer. See 'What Happens If Something Goes Wrong' on page 15 for further details.

4) Fast Freeze/Normal Operation

Switch:

This should be turned to 'N' except when you wish to start a fast freeze operation, when it should be turned to 'S'.

5) Freezer Thermostat Control:

Turn to a medium setting for normal operation.

6) Refrigerator Thermostat Control:

Turn to a medium setting for normal operation.

The Refrigerator

The fridge compartment provides suitable storage conditions for most kinds of fresh food, salads, milk etc.

Storage times will vary according to the type of food and how fresh it is when put into the fridge, but no food should be stored for longer than the times stated.

Suggested Maximum Storage Times

Type of Food

Uncooked Fresh Meat

| | |
|----------------------|----------|
| Poultry, Beef & lamb | 3-5 days |
| Pork | 2-4 days |
| Sausages | 3 days |
| Mince & Offal | 1-2 days |

Cooked Meat

| | |
|-------------------|----------|
| Ham, sliced meat | 2-3 days |
| Pies | 1 day |
| Casseroles & pate | 2 days |
| Bacon | 1 week |

Dairy Produce

| | |
|-------------|-----------|
| Milk | 2-3 days |
| Cream | 1 week |
| Butter | 3-4 weeks |
| Hard Cheese | 3-4 weeks |
| Soft Cheese | 1 week |

Vegetables & Salads

| | |
|--|--------|
| | 1 week |
|--|--------|

Fruit

| | |
|--|---------|
| | 2 weeks |
|--|---------|

To obtain the best results from the refrigerator, neither hot food nor liquids which may evaporate should be placed in the compartment.

Cover all food, especially those with a strong aroma.

Do not pack the fridge too tightly, or cover shelves with paper or card, as this would obstruct the free circulation of air.

Place meat to be stored in an airtight box.

Cooked food should be well covered.

Fruit and vegetables should be thoroughly cleaned and placed in the salad drawers.

Butter and cheese should be placed in special airtight containers or wrapped in foil or polythene bags to exclude as much air as possible.

Milk bottles should have a cap and should be stored in the bottle rack on the door.

Food should be positioned inside the refrigerator compartment as indicated in fig. 2.

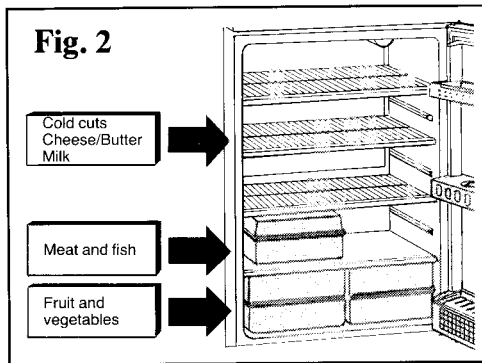

The absence of frosting is achieved by constant circulation of cold air inside the compartment, produced by an automatic fan.

The freezer compartment is suitable for storage of commercially frozen food marked with the symbol ****. The normal operating temperature of -18°C is suitable for long term storage of frozen food. Pre-packaged commercially frozen food is normally suitable for storage up to 3 months, unless otherwise stated by the manufacturer. It is also suitable for freezing fresh food. The bottom shelf is coldest and should be used to freeze fresh food.

To fast freeze, turn the control on the fascia to 'S' and the orange indicator light will come on to remind you that the fast freeze switch is in use.

The thermometer on the fascia indicates the operating temperature of the freezer. If the door is open often, or left open for too long, there may be a slight variation in the temperature indicated. There will be a marked variation if the quantity of food frozen at any one time exceeds the maximum recommended.

Door Shelves

The lower door shelf is provided with a special gripper to hold differing sizes of bottles securely. The position of this shelf cannot be altered. The remaining shelves can be located in six different positions to suit your own storage requirements. To remove any of these shelves, hold at each end and lift upwards. To re-fit, engage the groove on either side of the shelf onto the door location and slide the shelf downward.

Cabinet Shelves

The cabinet shelves can be adjusted to different positions to suit the size and amount of food being stored. To remove any shelf, grip the shelf on either side and pull forward.

The Freezer Compartment

The four star freezer compartment is of the 'frost free' type. This means that no frosting forms on the inner walls of the freezer compartment, or on the food during operation.

FREEZING FRESH FOOD

In any 24 hours you can freeze up to 13kg (28.6lb) of fresh food.

When the freezer is first turned on, turn the fast freeze switch on for 3 hours before putting in the food. If the freezer is already in use, turn the fast freeze switch on for 24 hours before freezing food, and leave for a further 24 hours before returning switch to normal conditions.

Place the food to be frozen on the bottom shelf of the freezer which is the coldest part. Transfer the food when the freezing process is completed to other shelves.

If a small quantity of fresh food is to be frozen, it is not necessary to activate the fast freeze switch in advance as it is sufficient to switch to 'S'(on) when the food is placed in the freezer. Always ensure that the food to be frozen is spaced apart in order to allow for the air to circulate around the packages.

If your fridge/freezer breaks down or the power fails, the food will not be affected for up to 15 hours as long as the freezer door is not opened during this period.

Ice Making

Fill the ice tray supplied, with water to just below the top of each compartment and place on the bottom shelf of the freezer. To release the cubes, twist the tray along its length.

Only freeze top quality, fresh and thoroughly cleaned food.
Do not allow fresh food to touch food which is already frozen.
During the freezing process, ensure that the freezer door remains closed.

Thawing

Deep frozen or frozen food, prior to being used, can be thawed either in the fridge or at room temperature, depending on the time available. Some small food items may be cooked from frozen but allow extra time for cooking.
Any frozen food which is allowed to thaw

incidentally should either be consumed as soon as possible or thrown away.

If the thawed food is uncooked and has not completely defrosted, it can be cooked and re-frozen.

DEFROSTED FOOD MUST NEVER BE REFROZEN.

IMPORTANT POINTS TO REMEMBER:

DO...

Adjust the level of your appliance before loading it with food.

Cover or wrap liquids and food, particularly those with strong odours.

Put vegetables and salads in the salad drawer, in plastic bags.

Cover melons and pineapples and only store for short periods.

Rotate stocks of frozen food; date markings will help with this.

Leave the door ajar when the fridge/freezer is not in use.

DO NOT...

Obstruct the air circulation in the fridge by tightly packing stored items.

Let food or containers touch the refrigerator cooling plate.

Store bananas in the fridge.

Use a sharp instrument to hasten defrosting or remove ice trays.

Do not place plastic parts in a dishwasher, they are not dishwasher-proof.

Pack the freezer so tightly that air is restricted as this will affect the performance of the frost free process.

LOOKING AFTER YOUR FRIDGE/FREEZER

Defrosting

The cooling plate in the refrigerator compartment is equipped with a fully automatic defrosting arrangement which comes into operation at each cycle of the thermostat.

The resultant water runs into the channel below the cooling plate and down through the tube into the evaporating tray at the rear of the appliance. The defrost water then evaporates automatically.

Important

The defrost water drain hole should be cleared at regular intervals to ensure that there are no food particles blocking it. To do this, use either a straw, pipe cleaner or thin, flexible wire (e.g. net curtain wire without the end hooks), and insert into the drain hole to a maximum of 6". (fig 2a).

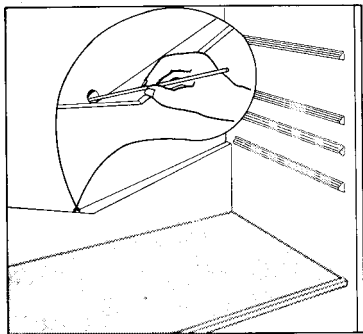

Fig. 2a

The freezer section defrosts automatically at regular intervals and no user maintenance is required.

Cleaning

The appliance should be cleaned at regular intervals. Before cleaning disconnect from the electricity supply, empty the cabinet and take out all the loose accessories.

Clean out the interior cabinet, door and accessories with a clean cloth wrung out in a solution of warm water and bicarbonate of soda (one teaspoon to 600ml/1 pint of water).

Cleaning the Drinks Dispenser

Rinse the container several times in hot water every time it is re-filled. For a thorough cleaning of the container, add a spoonful of bicarbonate of soda to the rinsing water. Push the dispenser tap on and off several times to allow sugar deposits from soft drinks or wines to dissolve or, alternatively, remove for cleaning by unscrewing in an anticlockwise direction. Empty the container and rinse thoroughly with clean water.

If you are using the dispenser to store fresh fruit juice, particular attention should be paid to the manufacturer's storage instructions. It is also advisable to clean the dispenser thoroughly between every filling, using a solution of sterilising fluid.

NEVER USE DETERGENTS, ABRASIVE POWDER, HIGHLY PERFUMED CLEANING MATERIALS OR WAX POLISHES TO CLEAN THE INTERIOR OF THE APPLIANCE AS THESE WILL DAMAGE THE SURFACES AND LEAVE A STRONG SMELL.

The exterior should be occasionally dusted or wiped over with a damp cloth and a small amount of detergent, but not the door seal which should be cleaned with a bicarbonate of soda solution.

A small amount of wax polish or silicon spray should be used to maintain the gloss finish of the outside cabinet.

The motor compressor and condenser should be cleaned of dust occasionally using a brush or vacuum cleaner.

Strong smelling food may leave the fridge with a slight odour. A small dish of bicarbonate of soda solution placed in the fridge should slowly absorb these smells.

During periods when the appliance is not in use, take the following precautions:

- * Unplug the appliance from the mains supply.
- * Remove all food from the appliance.
- * Clean the interior and all accessories, and leave the doors ajar after emptying, cleaning and drying the compartments to allow fresh air to circulate.

Replace The Interior Light Bulb

To replace the light bulb in the refrigerator section, first disconnect the appliance from the electricity supply. To release the plastic bulb cover from its holder, simply press inward from both sides and pull downwards and away from the holder. Unscrew the bulb, and replace it with a new one (maximum 15W) obtainable from either your local Zanussi Service Force Centre or High Street stores. Replace the cover and reconnect the electricity supply (fig 3).

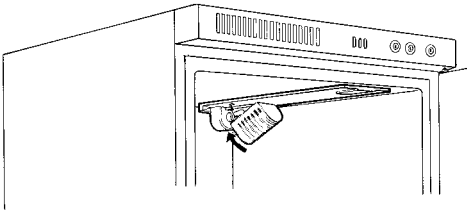

Fig. 3

Door Reversal

1. If your fridge/freezer is already in use, disconnect it from the electricity supply and remove shelves and other loose items, including food. Place the frozen food in boxes wrapped in blankets or other suitable insulating material and put in a cool place.
2. Gently lay the appliance on its back with the top held away from the floor by 5-8cm (2-3") of packing.

3. Remove the freezer door first by removing the three screws holding the bottom bracket in position (fig 4).

4. Lower the freezer door from its top pivot and set aside.

5. Unscrew the freezer door top pivot from the central bracket (fig 5) using the spanner provided. Set the pivot aside. This pivot also holds the fridge door so you should then be able to lower the fridge door easily from its top pivot. Set the door aside. Change the nut which rests on top of the bracket to the corresponding hold on the other side.

6. Unscrew the top pivot from its bracket (fig 6).

7. To refit the doors, screw the top pivot for the fridge door into the bracket on the opposite side.

8. Locate the fridge door onto this pivot and screw the bottom pivot through the hole in the central bracket to secure the fridge door.

9. Change the position of the pivot in the bottom bracket for the freezer door to the opposite hole in the bracket.

10. Locate the freezer door onto the top pivot and, holding it in position, push the bottom pivot into the locating hole and screw the attached bracket into the matching holes in the cabinet with the three screws removed from the other side.

11. Remove the two door handles by unscrewing them and refit on the opposite side.

HEALTH AND SAFETY GUIDELINES

Because of consumer demand, preservatives have been removed from many pre-prepared food.

This together with the changes in shopping habits to a once-a-week shop, mean that the safe handling and storage of food is even more important than ever.

The following tips should help you to ensure that the food in your home is in as perfect condition as possible.

- * Keep the time between buying chilled and frozen food and placing it in your fridge/freezer as short as possible. Tests showed that the temperature of 1 litre of orange juice rose to 22°C in an hour between the supermarket and home. It then took 11 hours to get down to 7°C in the refrigerator.
- * Be prepared to adjust the refrigerator thermostat control depending on circumstances. If you are adding a quantity of fresh food, turn the control to a higher number, to help the contents to cool faster.
- * Keep the refrigerator door closed as much as possible. Remember that warm air is flowing in as you are looking in to decide what to have for tea!
- * Do not push food together too much, try to allow air to circulate around each item.
- * Cool cooked food as quickly as possible but do not place in refrigerator or freezer until cool. (Leave food in a place as cool as possible in order that it can be placed in the refrigerator or freezer as soon as possible.)
- * Do not mix raw and cooked meat, they must be in separate containers. Take care not to let the meat juices drip onto other food. If the meat does drip, remove everything and clean thoroughly.
- * Do not store food uncovered.
- * The best way to defrost food is to put it in the fridge to thaw slowly.
- * Remove suspect food from your refrigerator and clean the interior with a solution of bicarbonate of soda in warm water (1 tbs to 1 litre of water).
- * Never allow food spills to dry and harden.
- * Ensure that food placed in the freezer is dated and labelled and used in date order to ensure that food is consumed at its best.
- * It is most most important that food is used before its 'best before' date.
- * Store eggs in the egg rack provided in the refrigerator door. Discard any broken or chipped ones.
- * Regularly check the refrigerator door seal to ensure that it is clean and free from bits and pieces.
- * Always wash your hands with soapy water and dry them with a clean towel before handling food.
- * Keep work surfaces clean and avoid cross contamination by not using the same work surface or knife, for raw and cooked food without washing them thoroughly in between.
- * Use clean kitchen roll wherever possible for cleaning up food. If you use a dishcloth be sure to boil wash it frequently.

WHAT HAPPENS IF SOMETHING GOES WRONG?

If your appliance fails to work properly, and you have followed these instructions carefully, contact your local Zanussi Service Force Centre, whose details can be found by looking under 'Z' in your local telephone directory. Before you do this, however, it is worth making the following checks:

- * Is the plug firmly connected to the wall socket and is the socket switched on?
- * Check the power supply by plugging in another appliance which you know is working.
- * Check that there is no power failure. Switch on the house lights.
- * Is the fuse in the plug intact and are the wires in the mains lead correctly connected to the plug? (see page 6 for Electrical Connections).
- * Have you turned the thermostat to the correct setting?
- * Has the door been left open causing the temperature to rise?

If there are water drops in the bottom of the fridge compartment, check that the defrost water channel is clear.

FAILURE TO OBSERVE THESE CHECKS COULD RESULT IN A CHARGE BEING MADE FOR THE SERVICE CALL.

*** Please note that it will be necessary to provide proof of purchase for any in-guarantee service calls.**

How to find the telephone number of your Zanussi Service Force.

Zanussi Service areas are allocated by postcodes which are listed in alphabetical order for easy reference.

1. Look for the first 2 letters of your address postcode in the far left 'Postcode' column.
2. Match up the number of your postcode against the number listed in the 'Postcode Numbers' column.
3. Look across the column to the Service Force Key Number for your area. Turn to the last page of this directory for the address and telephone number to contact for service which is listed against your key number.

If you are unsure of your postcode, the main towns and cities are listed in alphabetical order for easy reference.

Additionally, your local Zanussi Service Force Centre telephone number is listed under 'Z' in your telephone directory.

The Customer Care Department at Zanussi House, Hambridge Road, Newbury, Berks, RG14 5EP, Tel: 0635 521313, will be happy to help you with any queries or difficulties.

| Post-code Letter | Town | Post-code Number | Service Force Key Number | Post-code Letter | Town | Post-code Number | Service Force Key Number |
|------------------|-------------|--------------------|--------------------------|------------------------------|---------------|--------------------|--------------------------|
| AB | Aberdeen | 1-5 | 1 | DG | Dumfries | 8-9 | 36 |
| AL | St Albans | 1-10 | 2 | DH | Durham | 1-9 | 37 |
| A | Brecon | 45 | 3 | DL | Darlington | 1-17 | 37 |
| BA | Bath | 1-5, 11-15 | 4 | DN | Doncaster | 1-7, 10-12, 22 | 33 |
| BA | | 7-10, 20-22 | 5 | DN | | 14 | 38 |
| BA | | 6, 16 | 6 | DN | Doncaster | 8-9, 15-21, 31-40 | 39 |
| BB | Blackburn | 1-12 | 7 | | | | |
| BD | Bradford | 1-23 | 8 | SUB POSTCODE DIVISION | | | |
| BD | | 24 | 7 | DN | Gainsborough | | |
| BH | Bournemouth | 1-25 | 9 | | South | 21-1, 21-2, 21-5 | 40 |
| BL | Bury | 0-9 | 11 | DN | Gainsborough | | |
| BN | Brighton | 1-9, 11-15, | 12 | | North | 21-3, 21-4 | 39 |
| BN | | 20-27 | 12 | | | | |
| BN | | 16-18 | 13 | DT | Dorchester | 1-6, 10-11 | 9 |
| BR | Bromley | 1-8 | 14 | DT | | 6-9 | 5 |
| BS | Bristol | 1-28, 98-99 | 15 | SUB POSTCODE DIVISION | | | |
| BT | Belfast | 1-82 | 16 | DT | Bridport East | 6-3, 6-4 | 9 |
| B | Birmingham | 1-21, 25-33, | 17 | DT | Bridport West | 6-5, 6-6 | 5 |
| B | | 38, 40, 45, 47-48, | 17 | | | | |
| B | | 60-71, 80, 97-98 | 17 | | | | |
| B | Birmingham | 23-24, 34-37, | 18 | DY | Dudley | 1-6, 8-9 | 17 |
| B | | 42-44, 46, 72- | 18 | DY | | 7, 10-14 | 41 |
| B | | 79 | 18 | EC | London | All EC Codes | 28 |
| B | Birmingham | 49-50, | 19 | EH | Edinburgh | 1-42, 52-54 | 42 |
| B | | 96 | 19 | EH | | 43-46 | 35 |
| B | Birmingham | 95 | 20 | EH | Edinburgh | 47-49, 51, 55 | 43 |
| CA | Carlisle | 1-28 | 21 | EN | Enfield | 1-11 | 28 |
| CB | Cambridge | 1-8 | 22 | EX | Exeter | 1-17, 20 | 45 |
| CB | | 9-11 | 23 | EX | | 18-23, 31-39 | 46 |
| CF | Cardiff | 1-8, 31-48 | 3 | E | London | All East Codes | 28 |
| CH | Chester | 1-4 | 24 | FK | Falkirk | 1-4 | 43 |
| CH | | 5-7 | 25 | FK | | 10-14, 18-19 | 32 |
| CH | | 8 | 26 | FK | Falkirk | 5-9, 15-17 | 47 |
| CM | Chelmsford | 0-6, 8-9, 11-15 | 27 | FK | | 20-21 | 31 |
| CM | | 7 | 23 | FY | Fleetwood | 0-8 | 7 |
| CM | Chelmsford | 16-24 | 28 | GCI | Guernsey | | 48 |
| CO | Colchester | 1-16 | 23 | GL | Gloucester | 1-8, 10-19, | 49 |
| CR | Croyden | 0, 2-4, 9 | 29 | GL | | 50-56 | 49 |
| CT | Canterbury | 1-21 | 14 | GL | | 9 | 15 |
| CV | Coventry | 1-8, 10-12, 21-23 | 20 | GL | | 20 | 19 |
| CV | | 9, 13 | 18 | GU | Guildford | 1-24, 26, 34-35 | 50 |
| CV | Coventry | 31-35, 37 | 20 | GU | | 25 | 51 |
| CW | Crewe | 1-12 | 30 | GU | Guildford | 27-33 | 13 |
| DA | Dartford | 1-18 | 14 | G | Glasgow | 1-5, 11-15, 20-23, | 47 |
| DD | Dundee | 1-5, 7-11 | 31 | G | | 31-34, 40-46, 51- | 47 |
| DD | | 6 | 32 | G | Glasgow | 53, 58, 60-69, 73, | 47 |
| DE | Derby | 1-7, 13-15, 55 | 33 | G | | 76-78, 81-84 | 47 |
| DE | | 11-12 | 18 | G | Glasgow | 71-72, 74-75 | 43 |
| DG | Dumfries | 1-7, 10-12 | 34 | HA | Harrow | 0-9 | 2 |
| DG | | 13-14 | 35 | HD | Huddersfield | 1-8 | 8 |
| | | | | HG | Harrogate | 1-5 | 8 |

| Post-code Letter | Town | Postcode Number | Service Force Key Number | Post-code Letter | Town | Postcode Number | Service Force Key Number |
|------------------|-----------------|--|--------------------------|------------------|------------------|-------------------------------------|--------------------------|
| RM | Romford | 6, 8-9 | 28 | TQ | Torquay | 14 | 45 |
| SA | Swansea | 1-20, 31-32 | 3 | TR | Truro | 1-27 | 74 |
| SA | | 33-39, 41-44, 61-73 | 76 | TS | Stockton-on-Tees | 1-29 | 37 |
| SA | | 40, 45-48 | 77 | TW | Twickenham | 1-20 | 51 |
| SE | London | All SE Codes | 29 | UB | Uxbridge | 1-10 | 2 |
| SG | Stevenage | 1-9, 11, 15 | 2 | WA | Warrington | 1-5, 8-9, 10-15 | 11 |
| SG | | 10, 12-14 | 28 | WA | | 6-7 | 24 |
| SG | Stevenage | 16-19 | 22 | WA | Warrington | 16 | 30 |
| SK | Stockport | 1-3, 6-12 | 30 | WC | London | All WC Codes | 52 |
| SK | | 4-5, 13-16 | 11 | WD | Watford | 1-2, 4-7 | 2 |
| SK | Stockport | 17 | 33 | WD | | 3 | 53 |
| SL | Slough | 1-10 | 53 | WF | Wakefield | 1-17 | 8 |
| SM | Sutton | 1-3, 7 | 51 | WN | Wigan | 1-5, 7 | 11 |
| SM | | 4-6 | 29 | WN | | 6, 8 | 24 |
| SN | Swindon | 1-8, 11-16 | 65 | WR | Worcester | 1-14 | 19 |
| SN | | 9-10 | 4 | WR | | 15 | 41 |
| SO | Southampton | 1, 4, 41-43, 51 | 9 | WS | Walsall | 1-15 | 18 |
| SO | | 2-3, 5, 21-24, 52 | 13 | WV | Wolverhampton | 1-4, 10-14 | 18 |
| SO | Southampton | 20 | 4 | WV | | 5-9, 15-16 | 41 |
| SP | Salisbury | 1-5, 9-11 | 4 | W | London | All West Codes Except 3,4,5,7,13 | 52 |
| SP | | 6 | 9 | W | London | 3, 4, 5, 7, 13 | 2 |
| SP | Salisbury | 7-8 | 9 | YO | York | 1-3, 5, 7-8 | 8 |
| SR | Sunderland | 1-7, 9 | 66 | YO | | 4, 6, 11-18, 25 | 38 |
| SR | | 8 | 37 | YO | York | 21-22 | 37 |
| SS | Southend-on-Sea | 0-9, 11-17, 99 | 27 | ZE | Lerwick | 1,3 | 79 |
| ST | Stoke-on-Trent | 1-18, 20-21 | 30 | ZE | | 2 | 80 |
| ST | | 19 | 18 | | | | |
| SW | London | All SW Codes Except 2, 4, 8, 9, 11-20 | 52 | | | | |
| SW | London | 2, 9, 16 | 29 | | | | |
| SW | London | 4, 8, 11-15, 17-20 | 51 | | | | |
| SY | Shrewsbury | 1-6, 9-17, 18-22 | 25 | | | | |
| SY | | 7, 17-19 | 54 | | | | |
| SY | Shrewsbury | 8 | 41 | | | | |
| SY | | 23-25 | 77 | | | | |
| S | Sheffield | 1-19, 30-31, 40-45, | 33 | | | | |
| S | | 60-66, 74, 80-81 | 33 | | | | |
| S | Sheffield | 70-73, 75 | 8 | | | | |
| TA | Taunton | 1-11, 21-24 | 6 | | | | |
| TA | | 12-20 | 5 | | | | |
| TD | Selkirk | 1-15 | 35 | | | | |
| TF | Telford | 1-8, 10-13 | 41 | | | | |
| TF | | 9 | 30 | | | | |
| TN | Tonbridge | 1-2, 4, 8-18, 23-30 | 14 | | | | |
| TN | | 3, 5-7, 19-22, 31-40 | 12 | | | | |
| TQ | Torquay | 1-6, 9, 12-13 | 78 | | | | |
| TQ | | 7-8 | 73 | | | | |

| Service Force Key Number | Service Force Address | Telephone Number | Service Force Key Number | Service Force Address | Telephone Number |
|--------------------------|--|------------------|--------------------------|--|------------------|
| 1 | 60 Commerce Street, Aberdeen, AB2 1BP | 0224 583949 | 41 | 1 Underhill Street, Bridgnorth, Salop, WV16 | 0746 763322 |
| | or Tel: | 0224 582704 | 42 | 38 Buccleuch St, Dalkeith, Midlothian, EH22 | 031 663 7758 |
| 2* | Unit 4, Riverside Est, Coldharbour Ln, Harpenden | 0582 461909 | 43 | Block 2 Unit 5, Auchenraith Ind. Est. Rosendale Way, Blantyre | 0698 828145 |
| 3 | 3 Pentwyn Road, Blackwood, Gwent, Sth Wales | 0495 223151 | 45 | 91 Exeter Road, Exmouth, Devon, EX8 1QD | 0395 263531 |
| 4 | 31 St Andrews Road, Benerton, Salisbury, SP2 | 0722 336072 | 46 | 3 Bear St, Barnstaple, North Devon, EX32 | 0271 71774 |
| 5 | 31 East Street, Crewkerne, Somerset, TA18 | 0460 72740 | 47 | Unit E6C Anniesland Ind. Est. Netherton Rd, Glasgow, Scotland | 041 954 5304 |
| 6 | 80 Killigrew Street, Falmouth, Cornwall, TR11 | 0984 31858 | | or Tel: | 041 954 5349 |
| 7 | 333 Ranglet Road, Walton Summit, Preston, PR5 | 0772 321200 | 48 | Blencathra, Saumarez Lane, Castel, Guernsey | 0481 56854 |
| 8 | 7 Crown Street, Leeds, Yorks, LS2 | 0532 460992 | 49 | 134 Eastgate Street, Gloucester, GL1 1QT | 0452 422488 |
| 9 | 63 Curzon Road, Bournemouth, BH1 4PW | 0202 303363 | 50 | Unit 1 Redfields Ind. Pk, Church Crookham, Fleet | 0252 851414 |
| 11 | Unit 41/42 Clarendon Ct, Winwick Quay, W'ton | 0925 50822 | 51 | 127 Walton Road, Molesey, Surrey, KT8 0DT | 01 979 6366 |
| 12 | Unit 3, 21/25 Bridge Road, Haywards Heath, RH1 | 0444 417656 | | or Tel: | 01 979 7962 |
| 13 | 266 Main Road, Southbourne, Emsworth, PO10 | 0243 374814 | 52* | Unit 4, Riverside Est, Coldharbour Ln, Harpenden | 0582 461909 |
| | or Tel: | 0243 371170 | 53 | Reform Road, Maidenhead, Berkshire | 0628 783711 |
| 14 | Bridgewood Hse, 8 Laker Road, Rochester, ME1 | 0634 201441 | 54 | Merion House, High Street, Llandrindod Wells | 0597 824842 |
| | or Tel: | 0689 61444 | 55 | Tromode Wks, Cronkbourne Vill, Douglas, I.O.M. | 0624 76066 |
| 15 | 89 Stoke Croft Road, Bristol, Avon, BS1 3RD | 0272 246271 | 56 | Unit 2b, Elton Park Business Centre, Hadleigh Road, Ipswich, IP2 0DQ | 0473 211713 |
| | or Tel: | 0272 246378 | 57 | 75 Grove Road, Norwich, NR1 3RL | 0603 629653 |
| 16 | Owenmore Hse, Kilwee Ind. Est., Upper Dunmurry Lane, Belfast | 0232 301121 | 58 | Unit 3B3, Smithton Ind. Est. Smithton, Inverness | 0463 791822 |
| 17 | 66 Birch Rd East, Wyreley Rd Ind. Est, B'ham | 021 327 1671 | 59 | Main Street, Golspie, Sutherland, KW10 6RA | 040 833517 |
| 18 | Unit 3 Sterling Park, Claymore, Tamworth | 0827 289800 | 60 | P.O.Box 45, Queens Road, St Helier, Jersey | 0534 67001 |
| | or Tel: | 0827 289822 | 61 | Bruach, Blackwaterfoot, Isle of Arran | 077 086 246 |
| 19 | 22 Newton Road, Malvern, Worcs, WR14 1NZ | 0684 572915 | 62 | Hatson Ind. Estate, Kirkwall, Orkney | 0856 5457 |
| 20 | Unit 3, Bryant Road, Exhall, Coventry | 0203 644277 | 63 | 30a Scotland Road, Market Harborough, LE16 | 0858 33229 |
| 21 | High Ehenside, Egremont, Cumbria, CA22 | 0946 820509 | 64 | Pinfold Rd, Manning Rd Ind. Est. Bourne, Lincs | 0778 422147 |
| 22 | 1 Wharf Road, Higham Ferrers, Northants | 0933 317727 | 65 | Unit E19, Telford Rd, Launton Ind. Est. Bicester | 0869 248598 |
| 23 | Unit 18, Fourth Ave, Bluebridge Ind. Est, Halstead, Essex | 0787 473982 | 66 | Unit C1, Bergen Cl, Tyne Tunnel Trad. Estate, North Shields, Tyne & Wear | 091 2960166 |
| 24 | Unit 14, Dock Road, Birkenhead, L41 1JJ | 051 639 1287 | 67 | 53 Sandringham Road, Northampton, NN1 | 0604 37061 |
| 25 | Plas Fynnon W'house, Middleton Rd, Oswestry | 0691 652917 | 68 | 96 Argyll Street, Dunoon, Argyll, PA23 7NE | 0369 2147 |
| 26 | Easy Launderette, Pantton Hall, Denbigh, Clwyd | 074 571 3272 | 69 | 43 Crosshill Avenue, Cameltown, Argyll | 0586 52008 |
| 27 | 19 Sirdar Rd, Off Brook Rd, Rayleigh, Essex | 0268 741171 | 70 | Moss Field Workshop, Moss Field Drive, Oban | 0631 664530 |
| 28 | 284 Alma Road, Enfield, EN3 | 01 805 6825 | 71 | 2 Kiltweivagh, Gregory, Benbecula, Outer Hebrides | 0870 2331 |
| 29 | 194 Court Road, Eitham, London, SE9 4EN | 01 859 3939 | 72 | Churchouse, 16 James St, Stornaway, Isle of Lewis | 0851 5555 |
| 30 | Unit 8, Croft Road, Newcastle under Lyme, Staffs, ST5 0TW | 0782 713003 | 73 | 6 Embankment Ln, Embankment Rd, Plymouth | 0752 222540 |
| 31 | 3-7 Blackness Street, Dundee, Scotland, DD1 | 0382 642828 | 74 | 80 Killigrew Street, Faimouth, Cornwall, TR11 | 0326 314600 |
| | or Tel: | 0382 455862 | 75 | 109-111 Hunnyhill, Newport, Isle of Wight | 0983 523062 |
| | or Tel: | 0382 826809 | 76 | Roch, Haverfordwest, Dyfed | 0437 710366 |
| 32 | 33a Burnside, Auchtermuchty, Fife, Scotland | 0337 28807 | 77 | 4 Market Street, Aberaeron, W. Wales, SA46 | 0545 570254 |
| 33 | Unit 63, Storforth Ln Trad. Est. Chesterfield | 0246 231790 | 78 | 278 Torquay Road, Preston, Paighton | 0803 529969 |
| 34 | 93 Irish Street, Dumfries, Scotland | 0387 69694 | 79 | 3-4 Carlton Place, Lerwick, Shetland, ZE1 | 0595 2915 |
| 35 | 2-8 Wood Market, Kelso, Borders, TD5 7AX | 0573 24411 | 80 | Harlsdale, Symbister, Whalasay, Shetland | 08066 546 |
| 36 | 27 Antrim Ave, Stranraer, Dumfries & Galloway | 0776 3277 | | | |
| 37 | 8 Cumbie Way, Aycliffe Ind. Est. Newton Aycliffe | 0325 300606 | | | |
| 38 | Unit 1, Boulevard Unit Fact. Est. Hull, HU3 4AY | 0482 223335 | | | |
| 39 | Unit 2, Cromwell Road, Grimsby, DN31 2BN | 0472 358760 | | | |
| 40 | Unit 14 Stonefield Park, Clifton Street, Lincoln | 0522 532330 | | | |

PEACE OF MIND FOR TWELVE MONTHS

Zanussi Standard Guarantee Conditions

This guarantee is in addition to your statutory and other legal rights which will not be excluded or in any way diminished by the return of the guarantee card.

Zanussi Ltd, undertake that if within twelve months of the date of the purchase, this ZANUSSI appliance or any part thereof is proved to be defective by reason only of faulty workmanship or materials, the company will, at our option, repair or replace the same FREE OF ANY CHARGE for labour, materials or carriage on condition that:

- * The appliance has been correctly installed and used only on the electricity supply stated on the rating plate.
- * The appliance has been used for normal domestic purposes only, and in accordance with the manufacturer's operating and maintenance instructions.
- * The appliance has not been serviced, maintained, repaired, taken apart or tampered with by any person not authorised by us.
- * The appliance is still in the possession of the original purchaser.

All service work under this guarantee must be undertaken by a Zanussi Service Force Centre.

Any appliance or defective part replaced shall become our property.

Appliances found to be in use within a commercial environment, plus those which are the subject of rental agreements.

Exclusions

This guarantee does not cover:

- * Damage or calls resulting from transportation, improper use or neglect, the replacement of any light bulbs or removable parts of glass or plastic.
- * Costs incurred for calls to put right machines improperly installed, or calls to machines outside the UK and the Republic of Ireland.
- * Products of Zanussi manufacture which are NOT marketed by Zanussi Ltd.
- * EEC Countries - the standard guarantee is applicable but is subject to the owner's responsibility and cost to ensure the appliance meets the standards set by the country to which the product is taken. The Zanussi company in the country concerned will be pleased to advise you further. Sight of your purchase receipt will be required by them.

OR FIVE YEARS

Zanussi 5 Year Cover Conditions

For a once only payment you can extend your Standard Guarantee to 5 years, all the conditions and exclusions of the Standard Guarantee apply.

Note

1. The issue of a cover does NOT by virtue of our having done so, nullify the exclusions.
2. The engineer will need to check the details of your Cover Card or Certificate and may make a charge for his services if it is not presented to him at the time of his call.
3. The date of purchase, or the date of initial payment (deposit) of the appliance will be deemed the date of commencement of cover.
4. Covers issued are NOT refundable or transferable.

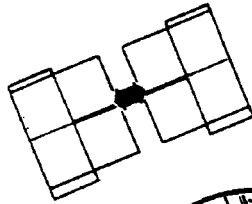

Fig. 5

Fig. 4

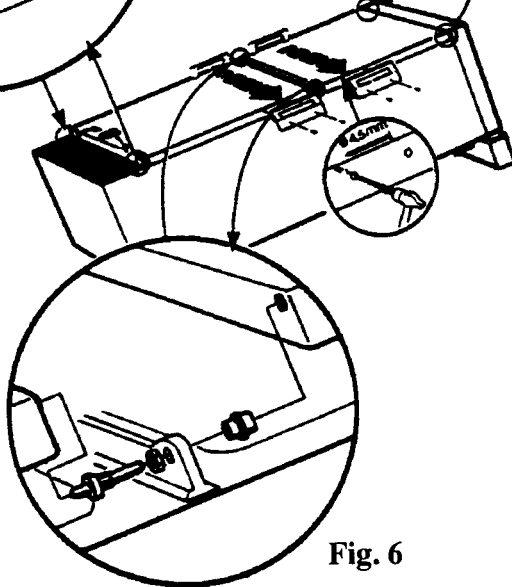
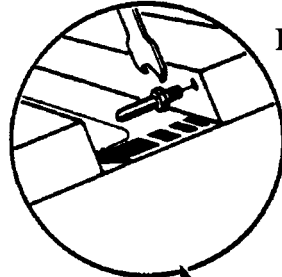
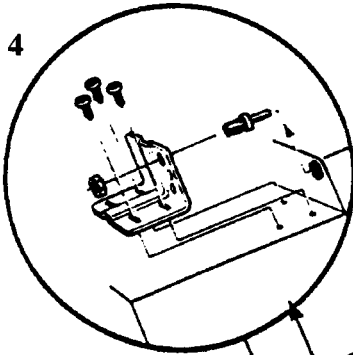

Fig. 6



ZANUSSI

The Appliance of Science