

MODEL W1675 13" Portable Planer



INSTRUCTION MANUAL

Phone: 1-360-734-3482 • On-Line Technical Support: tech-support@shopfox.biz

COPYRIGHT © NOVEMBER, 2002 BY WOODSTOCK INTERNATIONAL, INC.
WARNING: NO PORTION OF THIS MANUAL MAY BE REPRODUCED IN ANY SHAPE OR FORM WITHOUT
THE WRITTEN APPROVAL OF WOODSTOCK INTERNATIONAL, INC.

Printed in Taiwan

WARNING

Some dust created by power sanding, sawing, grinding, drilling, and other construction activities contains chemicals known to the State of California to cause cancer, birth defects or other reproductive harm. Some examples of these chemicals are:

- Lead from lead-based paints.
- Crystalline silica from bricks, cement, and other masonry products.
- Arsenic and chromium from chemically treated lumber.

Your risk from these exposures varies, depending on how often you do this type of work. To reduce your exposure to these chemicals: work in a well ventilated area, and work with approved safety equipment, such as those dust masks that are specially designed to filter out microscopic particles.

TABLE OF CONTENTS

	PAGE
INTRODUCTION	2
About Your New Planer	2
Woodstock Service and Support.....	2
Warranty and Returns	3
Specifications	3
SAFETY FIRST	4
Standard Safety Instructions	4-5
ADDITIONAL SAFETY INSTRUCTIONS FOR PLANERS	6
Avoiding Potential Injuries	7
ELECTRICAL	8
110V Operation	8
Extension Cords.....	8
Grounding	8
ASSEMBLY	9
Unpacking	9
Box Contents	9
Shop Preparation	9
Cleaning Machine	10
Beginning	10
Mounting	11
Handwheel	12
Dust Port	12
ADJUSTMENTS	13
Controls.....	13
Turning / Changing Knives	14
Extension Tables	17
OPERATIONS	18
Starting the Planer	18
Basic Operations	19
Troubleshooting.....	21
MAINTENANCE	22
Lubrication	22
General	22
Brush Replacement.....	22
Table and Base	22
CLOSURE	23
Parts Breakdown and Parts List	24-27
Your Notes	28

USE THE QUICK GUIDE PAGE LABELS TO SEARCH OUT INFORMATION FAST!





INTRODUCTION

About Your New Planer

Your new **SHOP FOX**® Planer has been specially designed to provide many years of trouble-free service. Close attention to detail, ruggedly built parts and a rigid quality control program assure safe and reliable operation.

The Model W1675 is a great portable planer that packs an impressive punch for its size. Unlike most planers of similar size, the Model W1675 takes stock to a maximum width of 13" which further expands your planing capabilities. The Model W1675 has many features and gives excellent planing results and years of service.

Woodstock International, Inc. is committed to customer satisfaction in providing this manual. It is our intent to make sure all the information necessary for safety, ease of assembly, practical use and durability of this product be included.

If you should have any comments regarding this manual, please feel free to contact us at:

Woodstock International, Inc.
Attn: Technical Department
P.O. Box 2309
Bellingham, WA 98227

Woodstock Service and Support

We stand behind our machines! In the event that a defect is found, parts are missing or questions arise about your machine, please contact Woodstock International Service and Support at 1-360-734-3482 or send e-mail to: tech-support@shopfox.biz. Our knowledgeable staff will help you troubleshoot problems, send out parts or arrange warranty returns.

Warranty and Returns

Woodstock International, Inc. warrants all **SHOP FOX**® machinery to be free of defects from workmanship and materials for a period of 2 years from the date of original purchase by the original owner. This warranty does not apply to defects due directly or indirectly to misuse, abuse, negligence or accidents, lack of maintenance, or to repairs or alterations made or specifically authorized by anyone other than Woodstock International, Inc.

Woodstock International, Inc. will repair or replace, at its expense and at its option, the **SHOP FOX**® machine or machine part which in normal use has proven to be defective, provided that the original owner returns the product prepaid to the **SHOP FOX**® factory service center or authorized repair facility designated by our Bellingham, WA office, with proof of their purchase of the product within 2 years, and provides Woodstock International, Inc. reasonable opportunity to verify the alleged defect through inspection. If it is determined there is no defect, or that the defect resulted from causes not within the scope of Woodstock International Inc.'s warranty, then the original owner must bear the cost of storing and returning the product.

This is Woodstock International, Inc.'s sole written warranty and any and all warranties that may be implied by law, including any merchantability or fitness, for any particular purpose, are hereby limited to the duration of this written warranty. We do not warrant that **SHOP FOX**® machinery complies with the provisions of any law or acts. In no event shall Woodstock International, Inc.'s liability under this warranty exceed the purchase price paid for the product, and any legal actions brought against Woodstock International, Inc. shall be tried in the State of Washington, County of Whatcom. We shall in no event be liable for death, injuries to persons or property or for incidental, contingent, special or consequential damages arising from the use of our products.

Every effort has been made to ensure that all **SHOP FOX**® machinery meets high quality and durability standards. We reserve the right to change specifications at any time because of our commitment to continuously improve the quality of our products.

Specifications

Motor Size	2 HP, 110V, Universal
Amperage Draw	15
Maximum Width of Cut	13"
Maximum Depth of Cut at 13" Width	1/16"
Maximum Depth of Cut at 5" Width	1/8"
Maximum Cutting Height.....	6"
Minimum Stock Length	6"
Cutterhead	2 Knife, 1 ²⁹ / ₃₂ " Diameter
Cutterhead Speed	9000 RPM
Cuts Per Minute	18,000
Feed Rate	26 FPM
Machine Weight	93 lbs

SAFETY FIRST!

**READ MANUAL BEFORE OPERATING MACHINE.
FAILURE TO FOLLOW INSTRUCTIONS BELOW WILL
RESULT IN PERSONAL INJURY.**



Indicates an imminently hazardous situation which, if not avoided, **WILL** result in death or serious injury.



Indicates a potentially hazardous situation which, if not avoided, **COULD** result in death or serious injury.



Indicates a potentially hazardous situation which, if not avoided, **MAY** result in minor or moderate injury and/or damage to the machinery.

NOTICE

This symbol is used to alert the user to useful information about proper operation of the equipment.

Standard Safety Instructions

1. **Thoroughly read the instruction manual before operating your machine.** Learn the applications, limitations and potential hazards of this machine. Keep manual in a safe, convenient place for future reference.
2. **Keep work area clean and well lighted.** Clutter and inadequate lighting invite potential hazards.
3. **Ground all tools.** If a machine is equipped with a three-prong plug, it must be plugged into a three-hole grounded electrical outlet or grounded extension cord. If using an adapter to aid in accommodating a two-hole receptacle, ground using a screw to a known ground.
4. **Wear eye protection at all times.** Use safety glasses with side shields or safety goggles that meet the national safety standards, while operating this machine.
5. **Avoid dangerous environments.** Do not operate this machine in wet or open flame environments. Airborne dust particles could cause an explosion and severe fire hazard.
6. **Ensure all guards are securely in place and in working condition.**
7. **Make sure switch is in the "OFF" position** before connecting power to machine.
8. **Keep work area clean, free of clutter, grease, etc.**
9. **Keep children and visitors away.** Visitors should be kept a safe distance away while operating unit.
10. **Childproof workshop** with padlocks, master switches or by removing starter keys.
11. **Disconnect machine when cleaning, adjusting or servicing.**

- 12. **Do not force tool.** The machine will do a safer and better job at the rate for which it was designed.
- 13. **Use correct tool.** Do not force machine or attachment to do a job for which it was not designed.
- 14. **Wear proper apparel.** Do not wear loose clothing, neck ties, gloves, jewelry, keep long hair tied up, etc.
- 15. **Remove adjusting keys and wrenches.** Before turning the machine on, make it a habit to check that all adjusting keys and wrenches have been removed.

16. **Use proper extension cord.** Examine the extension cord to ensure it is in good condition. Use TABLE 1 to determine the correct length and gauge of extension cord needed for your particular needs. The amp rating of the motor can be found on its nameplate. If the motor is dual voltage, be sure to use the amp rating for the voltage you will be using. If you use an extension cord with an undersized gauge or one that is too long, excessive heat will be generated within the circuit increasing the chance of a fire or damage to the circuit. Always use an extension cord that uses a ground pin and connected ground wire. Immediately replace a damaged extension cord.

Extension Cord Requirements
TABLE 1

Amp Rating	Length and Gauge		
	25ft	50ft	100ft
0-6	#18	#16	#16
7-10	#18	#16	#14
11-12	#16	#16	#14
13-16	#14	#12	#12
17-20	#12	#12	#10
21-30	#10	#10	No

- 17. **Keep proper footing and balance** at all times.
- 18. **Do not leave machine unattended.** Wait until it comes to a complete stop before leaving the area.
- 19. **Perform machine maintenance and care.** Follow lubrication and accessory attachment instructions in the manual.
- 20. **Keep machine away from open flame.** Operating machines near pilot lights and/or open flames creates a high risk if dust is dispersed in the area. Dust particles and an ignition source may cause an explosion. Do not operate the machine in high-risk areas, including but not limited to, those mentioned above.

21. **If at any time you are experiencing difficulties** performing the intended operation, stop using the machine! Then contact our service department or ask a qualified expert how the operation should be performed.

22. **Habits—good and bad—are hard to break.** Develop good habits in your shop and safety will become second-nature to you.

⚠ WARNING

Always wear safety glasses or goggles when operating equipment. Operating this equipment creates the potential for flying debris that can cause eye injury. Everyday glasses or reading glasses only have impact resistant lenses, they are not safety glasses. Be certain the safety glasses you wear meet the appropriate standards of the American National Standards Institute (ANSI).





ADDITIONAL SAFETY INSTRUCTIONS FOR PLANERS

SAFETY



WARNING

Read and understand this entire instruction manual before using this machine. Serious personal injury may occur if safety and operational information is not understood and followed. Do not risk your safety by not reading!



CAUTION

Use this and other machinery with caution and respect and always consider safety first, as it applies to your individual working conditions. Remember, no list of safety guidelines can be complete and every shop environment is different. Failure to follow guidelines can result in serious personal injury, damage to equipment and/or poor work results.

1. **ALWAYS** make sure the planer is on firm ground and is stable before operating. Immediately fix or shim the planer if it rocks or wobbles.
2. **ALWAYS** inspect the workpiece before running it through the planer. Do not plane stock with loose knots, nails, staples, dirt or other foreign objects. Always reject the wood or correct the problems with the wood before planing.
3. **ALWAYS** make sure that all components of the planer are adjusted to their proper specifications before planing stock.
4. **ALWAYS** use the help of another person or some type of support fixture when planing long stock.
5. **ALWAYS** stand clear of the workpiece when you are feeding it into the planer; otherwise, the workpiece could possibly kick back and hit you or bystanders.
6. **ALWAYS** operate the planer with sharp and undamaged knives to achieve safe operation and quality planing results.
7. **ALWAYS** plane wood, never plane any material other than wood like particle board, MDF, or other wood products that are not natural wood grain. This planer is designed for wood only.
8. **ALWAYS** plane with multiple light cuts rather than excessively deep cuts.
9. **ALWAYS** wear hearing and eye protection and a dust mask when operating the planer.
10. **NEVER** attempt to free a stalled workpiece while the planer is powered on and plugged in.
11. **ABSOLUTELY NEVER** reach inside the planer or open the top cover while the planer is powered on and/or plugged in.
12. **NEVER** plane wood that is less than 6" long or less than 1/4" thick.

AVOIDING POTENTIAL INJURIES

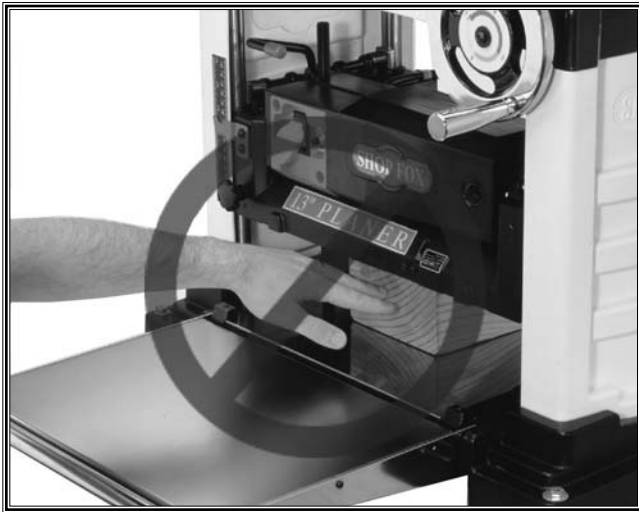

Figure 1. DO NOT place hands inside planer when operating.

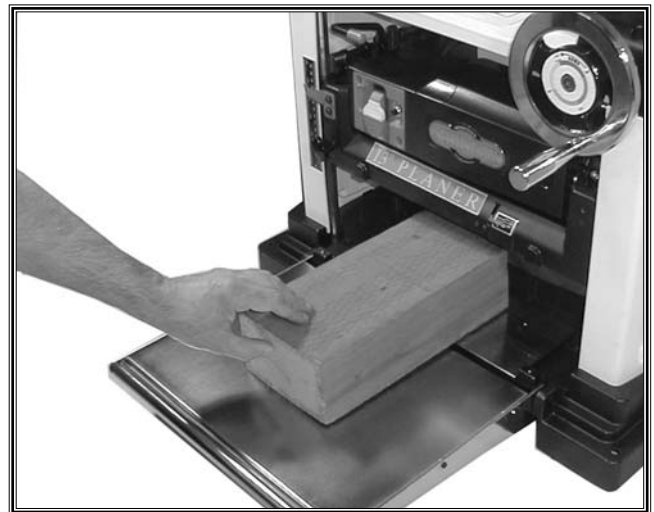

Figure 2. Feed wood by hand only until planer feed roller begins to pull wood inside planer.



Figure 3. DO NOT stand directly behind workpiece line of travel.



Figure 4. Stand out of the way of the workpiece line of travel.

ELECTRICAL

110V Operation

The SHOP FOX® W1675 is prewired for 110 volts. The 2 HP motor draws approximately 15 amps. Choose an outlet with 15 amp circuit breaker or fuse protection. Remember circuits being used by other machines at the same time add to the total electrical load being applied by this machine. Add up the amperage load ratings of all machines on the circuit. If this total amperage load exceeds the amperage rating of the circuit breaker or fuse, use a different circuit with a higher amperage rating.

DO NOT modify an existing low-amperage circuit by only replacing the circuit breaker with a breaker rated for a higher amperage. The breaker and the complete circuit must be replaced by a qualified electrician.

Extension Cords

Using extension cords with an undersized gauge or one that is too long, generates heat in the cord that may cause fire or circuit damage. If you must use an extension cord, use the guidelines below and TABLE 2 to determine the correct cord length and gauge. The amp rating of the motor is 15 amps and can be found on its nameplate.

- Use a cord rated for Hard Service (Grade S)
- Use a cord that is 100 feet or less only
- Use a cord with a ground wire and pin
- Use only undamaged cords

Extension Cord Requirements
TABLE 2

Amp Rating	Length and Gauge		
	25ft	50ft	100ft
0-6	#18	#16	#16
7-10	#18	#16	#14
11-12	#16	#16	#14
13-16	#14	#12	#12
17-20	#12	#12	#10
21-30	#10	#10	No

Grounding



⚠ WARNING
Any electrical outlet and circuit that you plug your machine into must be grounded. Serious injury and/or fire may occur if this warning is ignored!

Ground this machine! The electrical cord supplied with the Model W1675 comes with a grounding pin. Do not remove the pin if your outlet does not accept a ground pin, see Figure 5. Have the outlet box replaced by a qualified electrician or have an appropriate adapter installed.

NOTICE

Make sure when using an adapter, the adapter is grounded.

Remember, an adapter with a grounding wire does not guarantee the machine will be grounded. A ground source must always be verified in the electrical circuit within the wall or conduit.

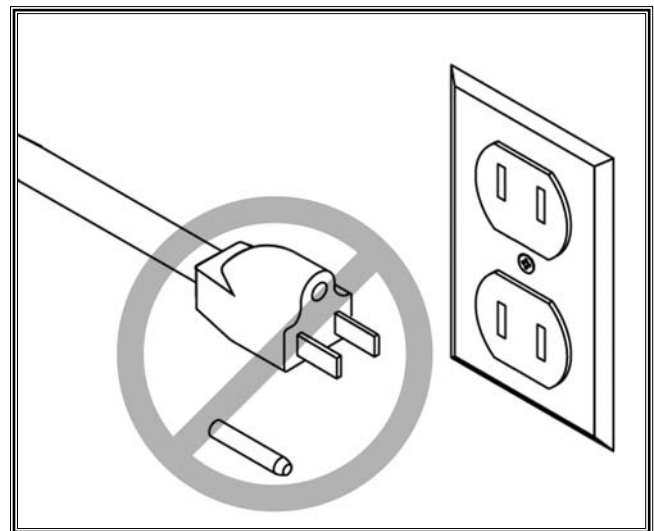
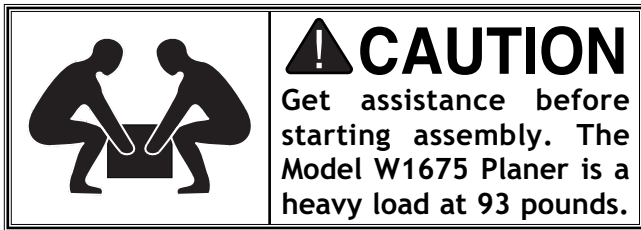

Figure 5. Never remove grounding pin.

ASSEMBLY

Unpacking



The planer is carefully packed. However, if it is damaged or is missing any parts, please contact Woodstock International Service and Support at 1-360-734-3482 or send e-mail to: tech-support@shopfox.biz.

Shop Preparation



Box Contents

Layout and inventory the parts shipped with your Planer. See Figure 6. This will help with machine assembly.

Item	Qty.
Planer Unit	1
Handwheel	1
Magnets	2
T-Handle Allen® Wrench	1
Allen® Screw	1
Flat/Lock Washer	1
Dust Port	1
Phillips® Screws	3

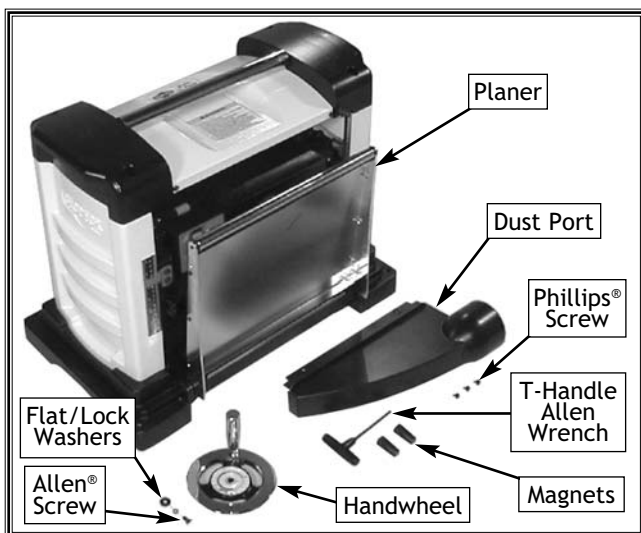

Figure 6. Planer components removed from the box and laid out for identification.

- **Planer Location:** Make sure that where ever you operate the planer, you face the planer toward an area where if a work piece should be projected, bystanders will not be struck with the workpiece. Take all necessary safety precautions.
- **Working Clearances:** Consider your existing and anticipated needs, size of material to be processed through each machine, and space for auxiliary stands, work tables or other machinery when establishing a location for your planer.
- **Lighting:** Make sure the lighting is bright enough to eliminate shadows and prevent eye strain.
- **Outlets:** Electrical circuits must be dedicated and/or large enough to handle the amperage requirements of the machinery. Electrical outlets should be located near each machine so power or extension cords are clear of high-traffic areas. Observe local electrical codes for proper installation of new lighting, outlets or circuits and read and understand this manual.

ASSEMBLY

Cleaning Machine

The Model W1675 table and other unpainted parts are coated with a waxy grease for corrosion protection. For the best machine performance, clean all moving parts and coated surfaces. Remove this grease with a solvent cleaner or a citrus-based degreaser. Do not use chlorine-based solvents—if you splash these solvents onto a painted surface, you will ruin painted and plastic finishes.

Before cleaning the machine, read and understand the following Warnings and Caution:

	<p>!WARNING Never use flammables such as gas or other petroleum-based solvents to clean your machine. These products have low flash points and present the risk of explosion and severe personal injury!</p>
--	--

	<p>!WARNING Never smoke while using cleaning solvents. Smoking may cause explosion or risk of fire when exposed to these products!</p>
--	--

	<p>!CAUTION Most solvents used to clean machinery are toxic when inhaled or ingested. When using these products, work in a well ventilated area and keep away from any potential ignition sources (pilot lights). Always dispose of any waste rags in a sealed container to make sure they do not cause fire or environmental hazards.</p>

Beginning

Although the main components of the SHOP FOX® W1675 are assembled at the factory, some assembly is required. The following series of instructions are the recommended sequence for final assembly.

All tools required for assembly have been included with the planer except standard-head and Phillips®-head screwdrivers.

	<p>!WARNING Keep your machine unplugged during any assembly, adjustments, or maintenance procedures. Ignoring this warning may result in serious personal injury!</p>
--	---

ASSEMBLY



Figure 7. SHOP FOX® Tool Stand.



Figure 8. Planer in mounted position.

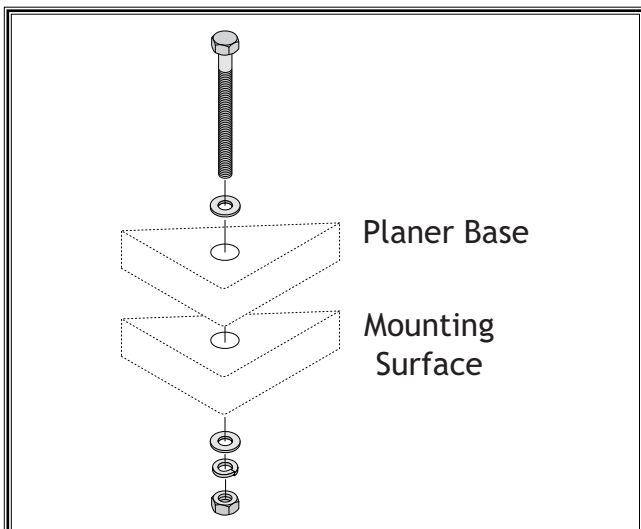

Figure 9. Hardware mounting assembly.

Mounting

For proper results and safe use, the Model W1675 must be mounted to a sturdy workbench or a stand like the SHOP FOX® Tool Stand shown in Figure 7. Mounting hardware is not included.

To mount the planer do these steps:

1. Determine the length of mounting bolts you will need by adding the thickness of your mounting surface and the base of the planer.
2. With the help of an assistant set the planer in the desired position on the mounting

	<p>CAUTION</p> <p>Get assistance before starting assembly. The Model W1675 Planer is a heavy load at 93 pounds.</p>
--	--

3. surface. See Figure 8.
4. Use a pencil to mark the positions of the mounting holes from the base of the planer.
5. Drill a 1/2" hole into your mounting surface in each of these positions.
6. Secure the planer with the mounting hardware. Figure 9 shows the proper order of the mounting hardware placement.
7. Insert a 1/2" diameter bolt, two flat washers (1 for top, 1 for bottom), and thread on a lock washer (for behind nut), and a hex nut to secure the planer at each corner.

<p>NOTICE</p> <p>DO NOT over tighten the bolts as damage to the base will result.</p>
--

Handwheel Handle

To mount the handwheel to the planer do these steps:

1. If not already done, insert the roll pin into the shaft protruding from the front of the planer. See **Figure 10**.
2. Slide the handwheel onto the shaft and align the handwheel with the roll pin.
3. Slide the lock washer on the Allen® screw first and then the flat washer.
4. Thread the Allen® screw into the end of the shaft to secure the handwheel to the shaft as shown in **Figure 11**.
5. Use the T-handle Allen® wrench and tighten the screw.

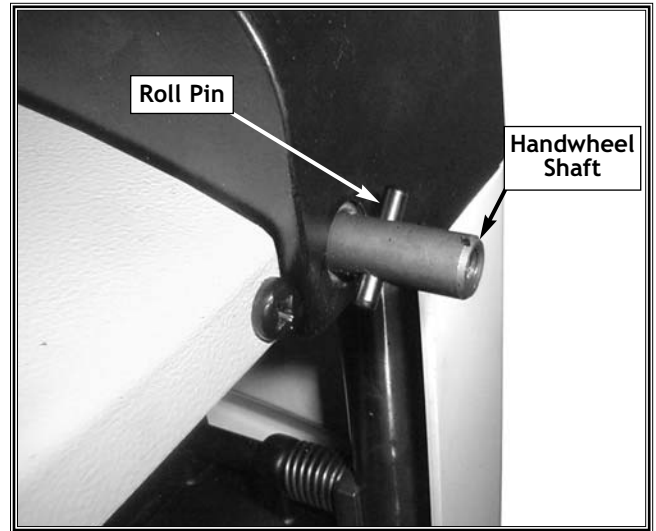

Figure 10. Insert the roll pin into shaft.

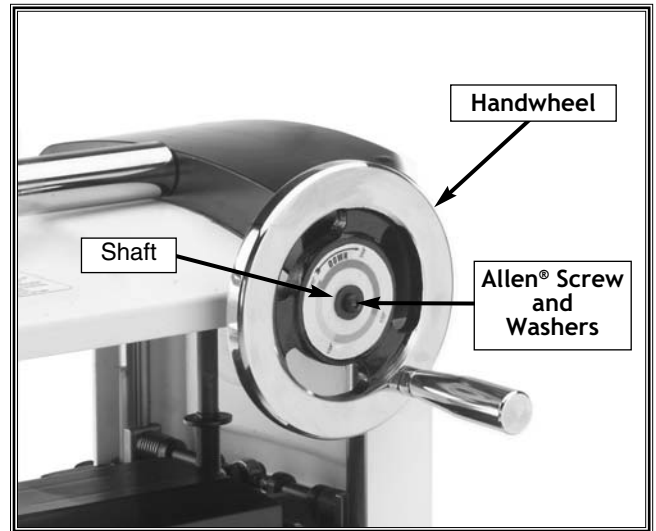

Figure 11. Handwheel mounted to the shaft.

Dust Port

To mount the dust port do these steps:

1. Position the dust port onto the chip deflector at back of the planer.
2. Thread and tighten the three Phillips® screws. **Figure 12** shows the dust port correctly installed on the planer.

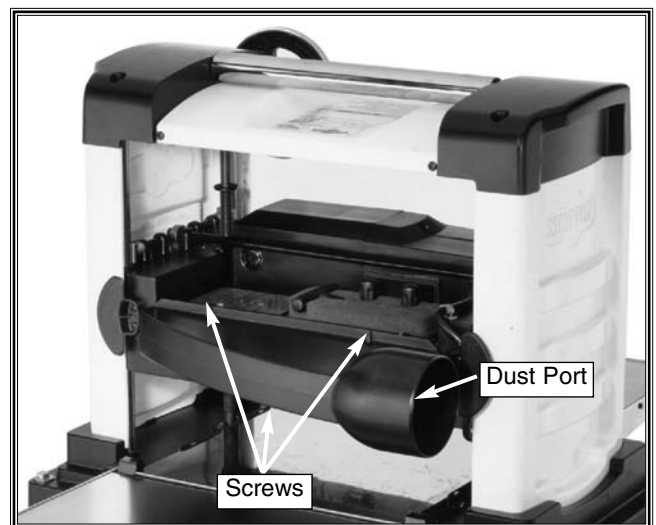

Figure 12. Dust port mounted to planer.

ADJUSTMENTS

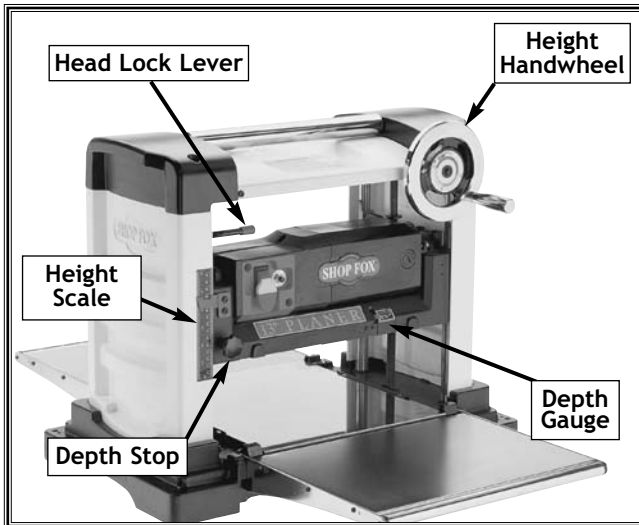

Figure 13. Machine controls.

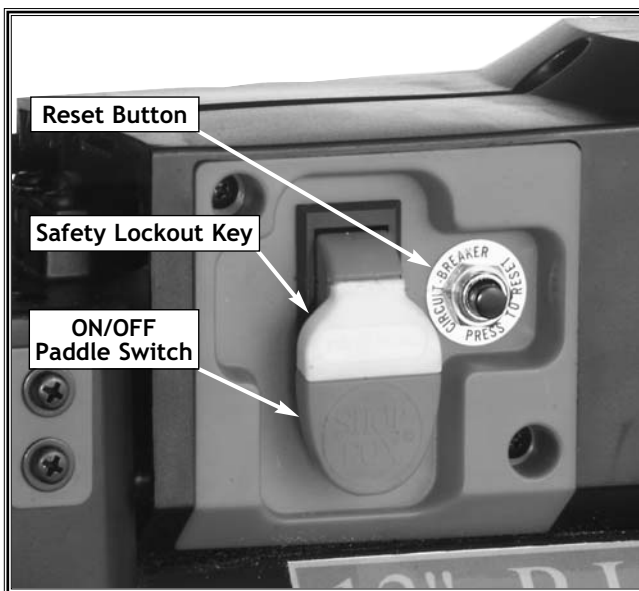

Figure 14. Electrical controls.

Controls

Familiarize yourself with the controls of your new planer. They will be frequently mentioned throughout the instructions in this manual, and the better you know your machine, the better you can make it perform. Use **Figure 13** and **Figure 14** to locate the planer controls.

- **Height Handwheel** – Allows you to adjust the head up or down to accommodate the workpiece height and control cutting depth. The wheel also has a turn vs. cutting depth guide. See **Figure 13**.
- **Head Lock** – Allows you to lock the head in place so that the cutter height setting will not move after adjustment. See **Figure 13**.
- **Depth Gauge** – Shows you the current depth of cut to be made on the workpiece. Only works when the workpiece is directly under the gauge. See **Figure 13**.
- **Height Scale** – Shows you the current cutterhead height adjustment. See **Figure 13**.
- **Depth Stop** – Allows you to lock the cutterhead to a set depth so the cutterhead lowest setting does not change when planing many boards. The cutterhead can be returned to the minimum setting quickly after planing thicker wood. See **Figure 13**.
- **Reset Button** – Allows you to reset the planer if the thermal overload shuts the machine down. Only resets after the machine has cooled down. See **Figure 14**.
- **Safety Lockout Key** – Allows you to protect the machine from accidental startup. Remove the key to disable the ON/OFF Paddle Switch, reinsert the key to enable the switch. See **Figure 14**.
- **ON/OFF Paddle Switch** – Allows you to toggle the planer power ON or OFF. Pull the switch up to turn the planer ON. Push the switch down to turn the planer OFF. See **Figure 14**.

Turning/Changing Knives

The Model W1675 features a 2 knife, quick change cutterhead system with double-sided, disposable knives. The knives have been installed at the factory and no adjustments are needed prior to using the planer.

As your planer gets used, the knives will need to be routinely inspected, turned around, and eventually replaced. After both sides are dull, install new knives.

	<p>!WARNING</p> <p>Keep your machine unplugged during any assembly, adjustments, or maintenance procedures. Ignoring this warning may result in serious personal injury!</p>
--	---

To remove the knives do these steps:

1. Unplug the planer!
2. Use a Phillips® screwdriver and remove the three screws that secure the dust port to the planer, and remove the dust port. See Figure 15.

<p>!WARNING</p>	<p>Wear heavy leather gloves when working with or near the cutterhead and planer knives. The knives are dangerously sharp and serious injury may occur.</p>
------------------------	---

3. Use the T-handle Allen® wrench and remove the two screws, and remove the chip deflector as shown in Figure 16.
4. Rotate the cutterhead pulley from the underside of the planer until the lock lever secures the cutterhead into position. See Figure 17.

	<p>!CAUTION</p> <p>Do not grab the cutterhead for any reason and be very careful working around the cutterhead. The knives are extremely sharp and severe injury may occur!</p>
--	--

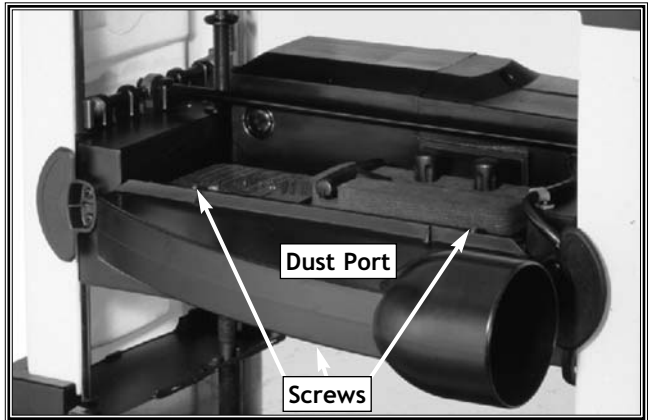

Figure 15. Remove the screws and dust port.

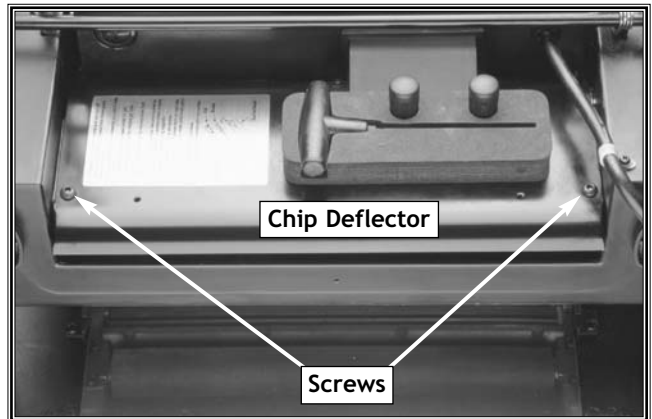

Figure 16. Remove the screws and chip deflector.

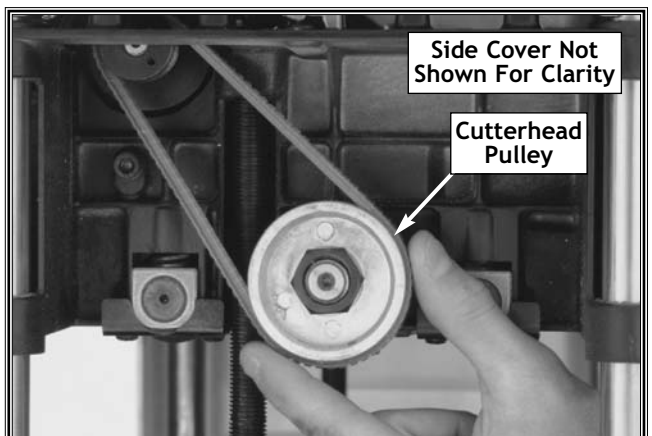

Figure 17. Rotate the cutterhead pulley until locked.

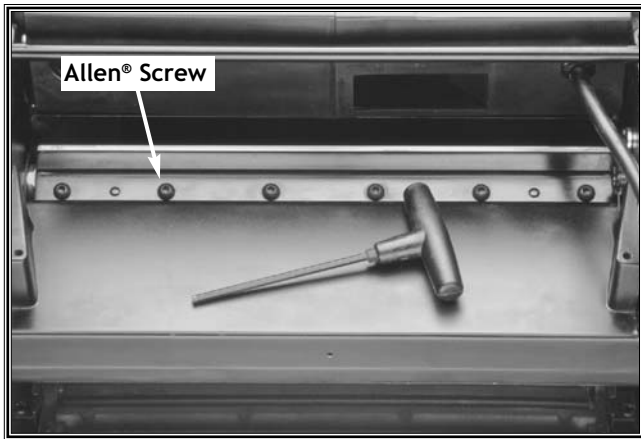

Figure 18. Remove six screws from the knife binder.

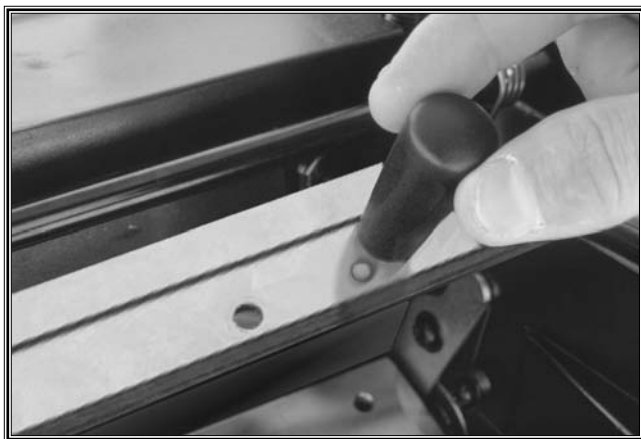

Figure 19. Lift out the locking plate with the magnets.

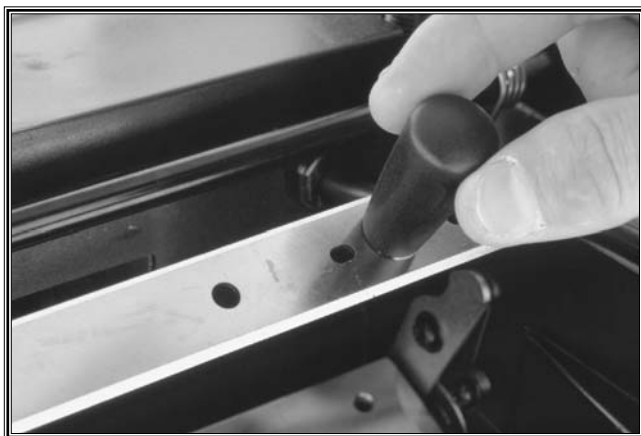

Figure 20. Lift out the knife with the magnets.

!WARNING

Wear heavy leather gloves when working with or near the cutterhead and planer knives. The knives are dangerously sharp and serious injury may occur.

5. Use the T-handle Allen® wrench that is included with the planer to remove the six screws from the knife locking plate. See **Figure 18**.
6. Use the included magnets to lift the locking plate from the cutterhead and out of the planer. See **Figure 19**.
7. Use the magnets to lift the knife from the the cutterhead and out of the planer. See **Figure 20**.
8. Carefully clean and inspect the cutterhead with a rag and inspect for the following:
 - Make sure the threaded screw holes contain no wood material or sawdust.
 - Make sure that the hex socket and the threads of all Allen® screws are in good condition. Replace if questionable.
 - Make sure any resin or glue build-up on the cutterhead is removed so the knife will sit flat on the cutterhead.
 - Make sure any resin or glue build-up on the knife is removed so the knife will sit flat on the cutterhead if you reuse the knife.
 - Make sure the knife is free of cracks. If any cracks exist replace both knives.

NOTICE

To maintain accurate and consistent planing results, Woodstock International Inc. does not recommend sharpening the knives. Replace the knives when they get dull.

⚠️ WARNING

Wear heavy leather gloves when working with or near the cutterhead and planer knives. The knives are dangerously sharp and serious injury may occur.

To install or turn the knives do these steps:

1. Unplug the planer.
2. Turn the knife to expose the unused blade or replace it if both blades are dull.
3. Set the magnets on the knife, so the beveled edge is facing you. See **Figure 21**.
4. Use the magnets to lower and seat the knife onto the cutterhead, and make sure the guides fit into the holes and the knife sits flat on the cutterhead. See **Figure 22**.
5. Use the magnets to lower and seat the knife binder onto the knife.

NOTICE

Uneven tightening of the knife binder retaining screws may cause the cutterhead and the knives to vibrate, wear prematurely, and produce poor planing results!

6. Use the T-handle Allen® wrench and thread all six screws into the the cutterhead until they just contact the knife binder. **DO NOT** tighten the screws yet.
7. Use the T-handle Allen® wrench and lightly tighten the screws into place, starting from the center and alternating back and forth toward the ends. Repeat this tightening sequence twice until all are snug. **DO NOT** over tighten.
8. Press the lock lever and rotate the cutterhead pulley until the cutterhead locks into position. See **Figure 23**.
9. Repeat all knife removal and installation steps on the remaining knife.
10. Make sure all knife binder screws are tight.
11. Reinstall the chip deflector and the dust port that was previously removed.



⚠️ CAUTION

Do not grab the cutterhead for any reason and be very careful working around the cutterhead. The knives are extremely sharp and severe injury may occur!

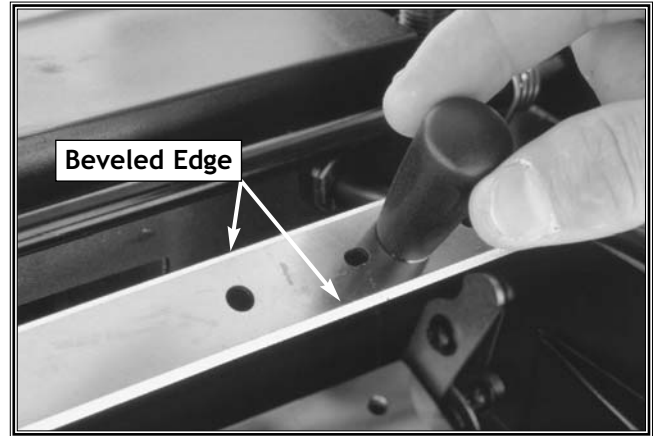

Figure 21. Position the magnets and blade taper.

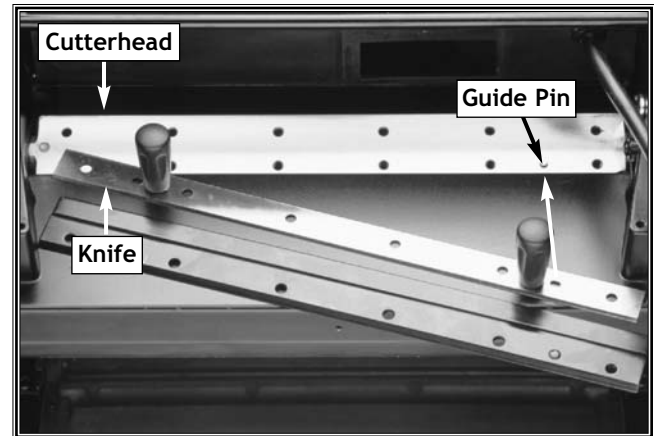

Figure 22. Position the knife on the cutterhead.

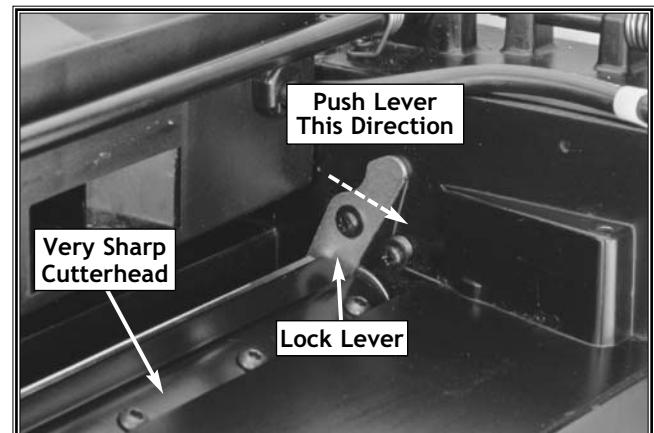

Figure 23. Push the cutterhead lock lever.

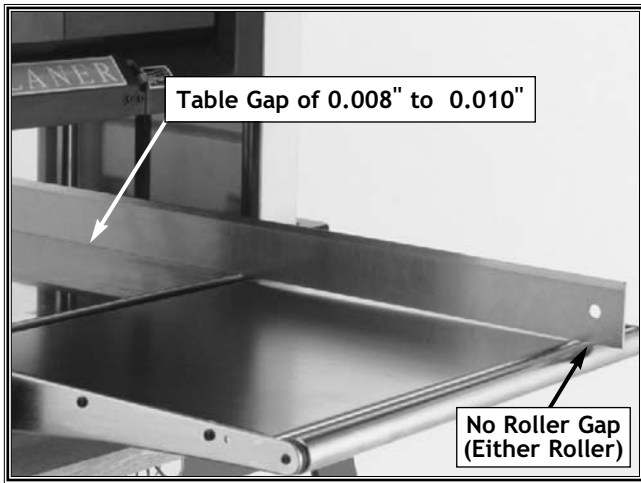

Figure 24. Check extension tables with a straightedge. The rollers on the ends of the tables should be even with the main table.

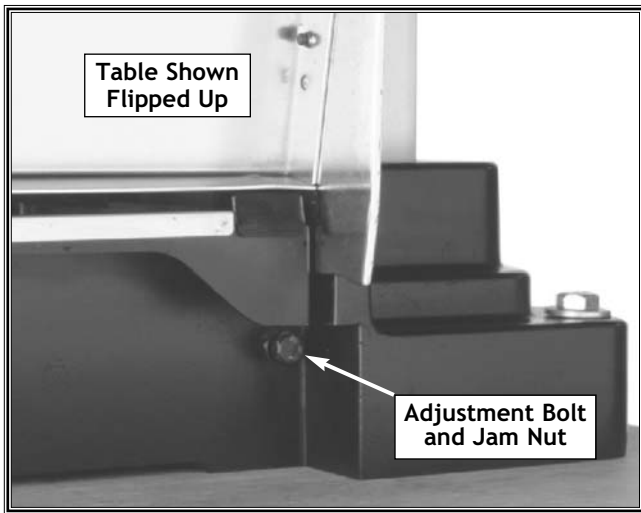
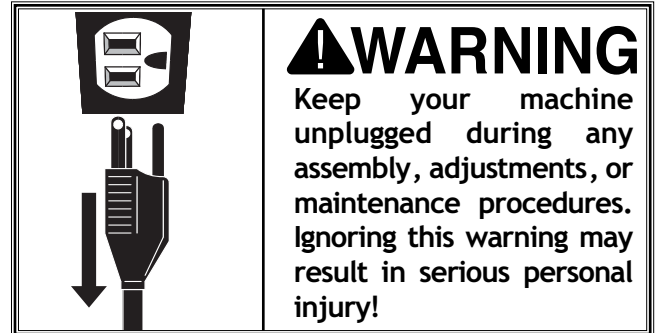

Figure 25. One of four extension table adjustment bolts.

Extension Tables

The extension tables have been set at the factory and require no adjustments upon initial operation. However, over the life of the planer, it is possible for the extensions to become misaligned with the main table and to need slight adjustment.



To check extension table alignment do these steps:

1. Unplug the planer!
2. Place a good quality, steel straightedge across both extension table rollers and the main table. The straightedge should be perfectly flat across the main table with a clearance of 0.008" to 0.010" measured with a feeler gauge, and the straight edge should evenly touch the rollers on the ends of the extension tables as shown in **Figure 24**.
3. If the rollers on the extension tables are not even or the straight edge does not have the correct gap with the main table, then the extensions need to be adjusted.
4. With the straightedge still in place, use the adjustment bolts shown in **Figure 25** to raise/lower the extension table.
5. Back off the adjustment-bolt jam nut (both sides of the planer) and raise/lower the extension table so there is no gap at the table rollers and an 0.008" to 0.010" gap at the main table under the straight edge.
6. Snug the adjustment bolts and double-check your setting. If the alignment is correct, then hold each bolt in position, and completely tighten the jam nut.
7. Repeat steps 1 through 6 for the other extension table roller.

OPERATIONS

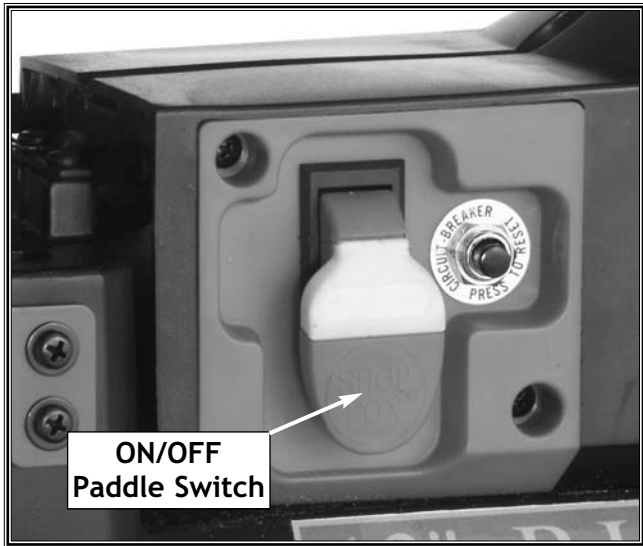

ON/OFF
Paddle Switch

Figure 26. Toggle the paddle switch for startup and shutdown.

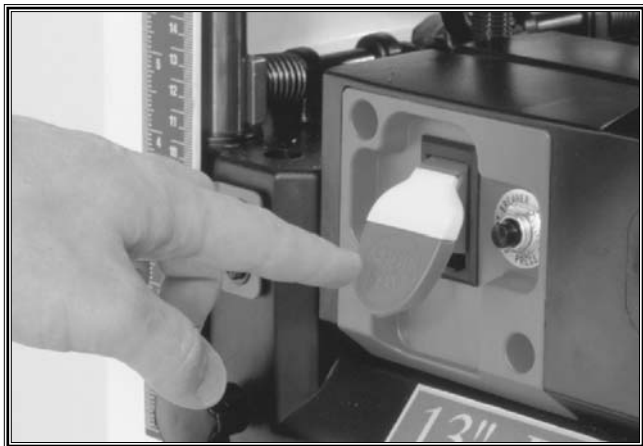

Figure 27. Position your finger over the paddle switch for emergency shutdown.

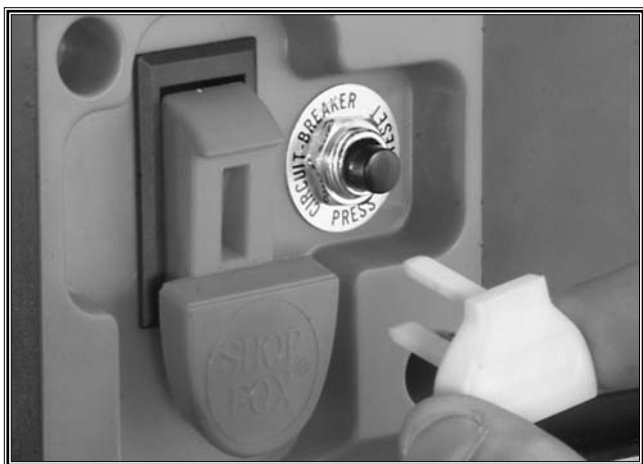

Figure 28. Remove the safety lockout key.

Starting the Planer

Once assembly is complete and adjustments have been made, the machine is ready for a test run. The purpose of a test run is to identify any unusual noises and vibrations, as well as to confirm the machine is performing as intended.

	<p>!WARNING Always wear a dust mask and safety glasses when operating this machine. Sawdust may cause allergic reactions or respiratory problems.</p>
--	--

	<p>!WARNING Make sure loose clothing and long hair is secured and kept away from moving parts.</p>
--	---

To test run the planer do these steps:

1. Flip the paddle switch up to turn the planer *ON*. See Figure 26.
2. Poise your finger over the paddle switch for emergency shut down if there is a problem. See Figure 27.
3. Listen for any unusual noises or vibrations, if unusual noise or vibration exists, shut the planer *OFF* immediately.
4. Unplug the planer and remove the safety lockout key. **DO NOT** make any adjustments while it is plugged in. See Figure 28.
5. Investigate the source of the noise or vibration. **DO NOT** start the planer again until the problem is corrected. Contact Woodstock International Service and Support at 1-360-734-3482 or send e-mail to: tech-support@shopfox.biz.
6. Repeat steps 1 through 5 until the planer runs smoothly.

Basic Operations

DO NOT operate this planer until you read and understand this entire manual first. If you have any questions contact Woodstock International.

	<p>!WARNING Always wear a dust mask and safety glasses when operating this machine. Sawdust may cause allergic reactions or respiratory problems.</p>
--	--

	<p>!WARNING Make sure loose clothing and long hair is secured and kept away from moving parts.</p>
--	---

To select and prepare the wood:

1. Choose clean wood only. See Figure 29. Scrape off all glue from joined boards before planing. Remove all dirt, nails, staples, and imbedded gravel, etc. A hidden nail in the wood will instantly damage the sharp edges of the knives and cause unsatisfactory results in all future planing operations. Plane only natural wood fiber. Never plane wood composites such as particle board, plywood or MFD. Never plane laminates, formica, or other synthetic materials.
2. Choose dry wood only. DO NOT plane wet wood or wood with a high moisture content. Wood that has been exposed to rain or snow and has more than a 20% moisture content, will plane poorly, dull the knives, and wear-out the motor. Excess moisture may cause rust and corrosion problems. Plane only KD (kiln-dried) wood and AD (air-dried) wood, which is correctly dried with no surface moisture. Never plane PAD (partially-air-dried) wood or you will have poor planing results.

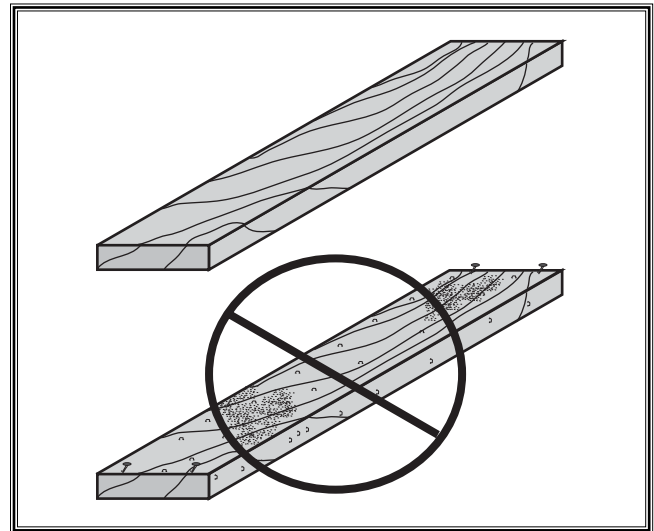

Figure 29. Only plane clean stock.

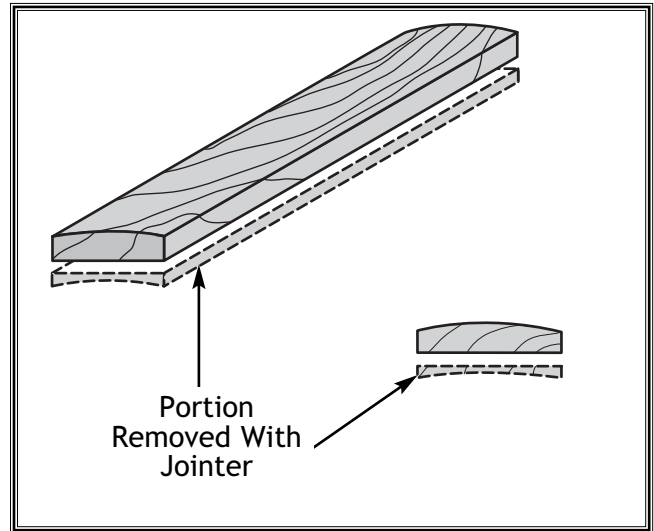

Figure 30. Face joint the concave side of cupped stock before planing.

3. Carefully inspect the wood you will feed into the planer. Each board must have at least one flat surface to slide along the planer table. To create a flat surface, pass the wood over a jointer first. See Figure 30. Some defects such as moderate twisting, loose knots or severe cracks may make the stock unplanable.

<p>NOTICE Inspect all lumber completely and remove all foreign material. Wood that has been stored on concrete floors is often imbedded with fine grit and small stones that will damage the knives.</p>

PLANER SETUP:

DO NOT plane wood that is shorter than six inches.

1. Use roller stands or roller tables to support and maintain alignment of long sections of wood while it enters and exits the planer, and make sure your work area is clear.
2. Position the wood on the infeed side of the planer extension table so the cutterhead will cut WITH the grain. Look at the grain pattern on the side of the board. If the arc of the cutterhead knife will follow the same lines in the grain pattern, you will be cutting WITH the grain. If the arc of the cutterhead knife will cross the grain pattern lines, then you will be cutting AGAINST the grain. DO NOT cut against the grain and, DO NOT feed end cut or end-grained wood in to the planer.
3. Unlock the head lock lever.
4. Measure the wood and turn the height handwheel to make a very light first cut about 1/32" or less, so if there is any bulges in the wood the cutterhead will not jam and stall. Subsequent cuts can be made at a deeper setting depending on the width of the wood, but plan on taking multiple cuts before you can achieve a completely flat surface.
5. Lock the head lock lever to save your cutterhead depth adjustment. For multiple surfacing, set and lock the depth stop also to maintain a particular cutterhead adjustment. The depth stop is a quick way to set the lowest height setting for planing many boards, but allows you to quickly return the cutterhead to the depth stop setting after having to adjust the cutterhead to a higher setting to compensate for varying heights of wood.

PLANING WOOD:

1. Put your safety glasses, dust mask, and hearing protection on.
2. Position yourself out of the way of the path of the wood as shown in **Figure 31**.



Figure 31. Notice that operator is feeding workpiece from the infeed side and has his body positioned to the side of the travel path.



Figure 32. DO NOT stand in the path of the planer outfeed because you can be hit with the workpiece.

3. Support the ends of the wood and turn the planer on.
4. Keeping your hands clear of the cutterhead, slowly and evenly push the wood into the planer until the planer feed roller draws the wood in, and then remove your hands from the area. DO NOT force the wood into the planer as you will dull the knives and overload the motor.
5. When the planing is complete, repeat all steps for additional wood.
6. When you are done with the planer, turn the machine off and remove the safety lockout key.

Troubleshooting

Planing Results

Planing results are affected by the species and condition of the wood, how the planer is setup, and the condition of the knives. The following characteristics are some common problems and the solutions woodworkers might have while planing.

SNIFE – More material is being removed from board ends rather than the middle of the board.

SOLUTIONS:

- Provide more support on the infeed and outfeed sides so the wood travels completely through the planer without any vertical tilting. This alignment problem occurs with all planers to some degree.
- Hold the workpiece flat against the planer tables and rollers so the board does not tilt while entering and exiting the planer.
- Install extra roller stands.
- Raise the table/ lift the board ends.

CHIP MARKS – Chips are not being properly expelled from the cutterhead. The chips get caught between the knives and the workpiece and hinder knife cutting ability. Chip marks usually appear as random and uneven.

SOLUTIONS:

- Unclog the chip deflector blockage and correct for cause of blockage.
- Increase cleaning intervals.
- Install a dust collector.

CHIPPED GRAIN – Grain shows cut marks and chips.

SOLUTIONS:

- Do not plane against the grain.
- Do not plane wood with knots or cross grain.
- Use sharp knives.
- Make shallower cuts.
- Surface acceptable stock.

FUZZY GRAIN – Grain fibers stand up on the workpiece after planing.

SOLUTIONS:

- Do not surface damp or wet wood, check it with a moisture meter. Anything over 20% should be allowed to dry.
- Install sharp knives.

GLOSSY SURFACE – The wood is scorched, blackened, and/or glossy.

SOLUTIONS:

- Remove all resin or glue build-up on the rollers and the cutterhead, and surface acceptable wood.
- Install sharp knives so shallow cuts do not have to be made to compensate for dull knives that burn the wood. If this is the case and the condition has existed for a long time, the knives may be damaged as a result and cannot be turned. The knives must be replaced.
- If knives are sharp and a glossy surface still results, increase the cutting depth.

THERMAL SWITCH POPS – The planer motor overheats and shuts off automatically.

SOLUTIONS:

- Push the reset button in when the planer completely cools down.
- Make shallower cuts.
- Remove all resin or glue build-up on the rollers and the cutterhead. Often resin or glue build-up can over-heat the planer by decreasing the cutter sharpness while increasing drag in the feed mechanism.
- Install sharp knives.
- Surface acceptable stock.

WOOD DOES NOT FEED CORRECTLY – The planer draws wood in erratically or slowly.

SOLUTIONS:

- Plane wood that is not twisted or warped
- Remove any pitch build-up on the feed rollers.
- Turn or replace the knives if they are dull or broken.

MAINTENANCE

Lubrication

Since all bearings are shielded and permanently lubricated, simply leave them alone until they need to be replaced. Do not lubricate them.

For other items on this machine and before occasionally applying lubricant, wipe the machine clean. Then apply a thin coat of light machine oil.

Remember your goal is to achieve corrosion protection. Too much lubrication will attract dirt and sawdust, which can damage your machine and cause parts to bind or stick.

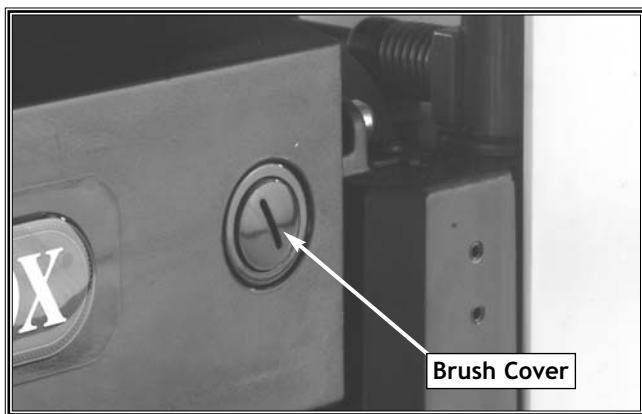

Figure 33. Remove the brush cover.

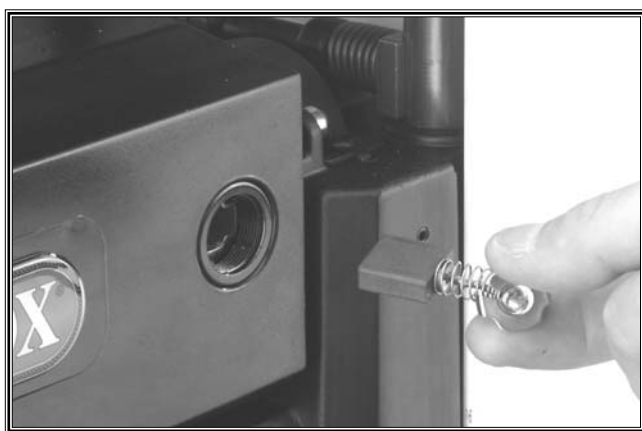

Figure 34. Remove/Install the motor brush.

General

To ensure best performance of your Model W1675, complete regular periodic maintenance. Make it a habit to inspect your machine each time you use it. Check for the following conditions and repair or replace when necessary.

- Loose mounting bolts.
- Worn switch.
- Excess buildup of sawdust.
- Worn or damaged cords and plugs.
- Worn or damaged drive belt.
- Any other condition that could hamper the safe operation of this machine.

Brush Replacement

	<p>!WARNING</p> <p>Keep your machine unplugged during any assembly, adjustments, or maintenance procedures. Ignoring this warning may result in serious personal injury!</p>
--	---

To replace the carbon brush do these steps:

1. **Unplug the planer!**
2. Use a flat-head screwdriver and remove the brush cover. See Figure 33.
3. Carefully slide out the spring and carbon brush. See Figure 34.
4. Insert the new carbon brush exactly like the old one was installed.
5. Replace cover.
6. Repeat steps 1 through 5 for the other motor brush on the other side of the motor.

Table and Base

Keep tables rust-free with regular applications of products like SLIPIT®. For long term storage, consider using products like Boeshield T-9™.

CLOSURE

The following pages contain parts diagrams/lists and a warranty card for your **SHOP FOX®** Model W1675.

If you need parts or help in assembling your machine, or if you need operational information, we encourage you to call our Service Department. Our trained service technicians will be glad to help you.

If you have comments dealing specifically with this manual, please write to us using the address in the General Information. The specifications, drawings, and photographs illustrated in this manual represent the Model W1675 as supplied when the manual was prepared. However, due to Woodstock International, Inc.'s policy of continuous improvement, changes may be made at any time with no obligation on the part of Woodstock International, Inc. Whenever possible, though, we send manual updates to all owners of a particular tool or machine that have registered their purchase with our warranty card. Should you receive one, add the new information to this manual and keep it for reference.

We have included some important safety measures that are essential to this machine's operation. While most safety measures are generally universal, we remind you that each workshop is different and safety rules should be considered as they apply to your specific situation.

We recommend you keep this manual for complete information regarding Woodstock International, Inc.'s warranty and return policy. Should a problem arise, we recommend that you keep your proof of purchase with your manual. If you need additional technical information relating to this machine, or if you need general assistance or replacement parts, please contact the Service Department at 1-360-734-3482 or e-mail: tech-support@shopfox.biz.

Additional information sources are necessary to realize the full potential of this machine. Trade journals, woodworking magazines, and your local library are good places to start.

The Model W1675 is specifically designed for PLANING operations. **DO NOT MODIFY AND/OR USE THIS MACHINE FOR ANY OTHER PURPOSE. MODIFICATIONS OR IMPROPER USE OF THIS TOOL WILL VOID THE WARRANTY.** If you are confused about any aspect of this machine, **DO NOT** use it until all your questions have been answered.

<p>⚠️ WARNING</p> <p>Use this machine with respect and caution to lessen the possibility of mechanical damage or operator injury. As with all power tools, there is danger associated with the Model W1675. If normal safety precautions are overlooked or ignored, injury to the operator or others in the area is likely.</p>
--

<p>⚠️ WARNING</p> <p>Always wear safety glasses or goggles when operating equipment. Operating this equipment creates the potential for flying debris that can cause eye injury. Everyday glasses or reading glasses only have impact resistant lenses, they are not safety glasses. Be certain the safety glasses you wear meet the appropriate standards of the American National Standards Institute (ANSI).</p>		

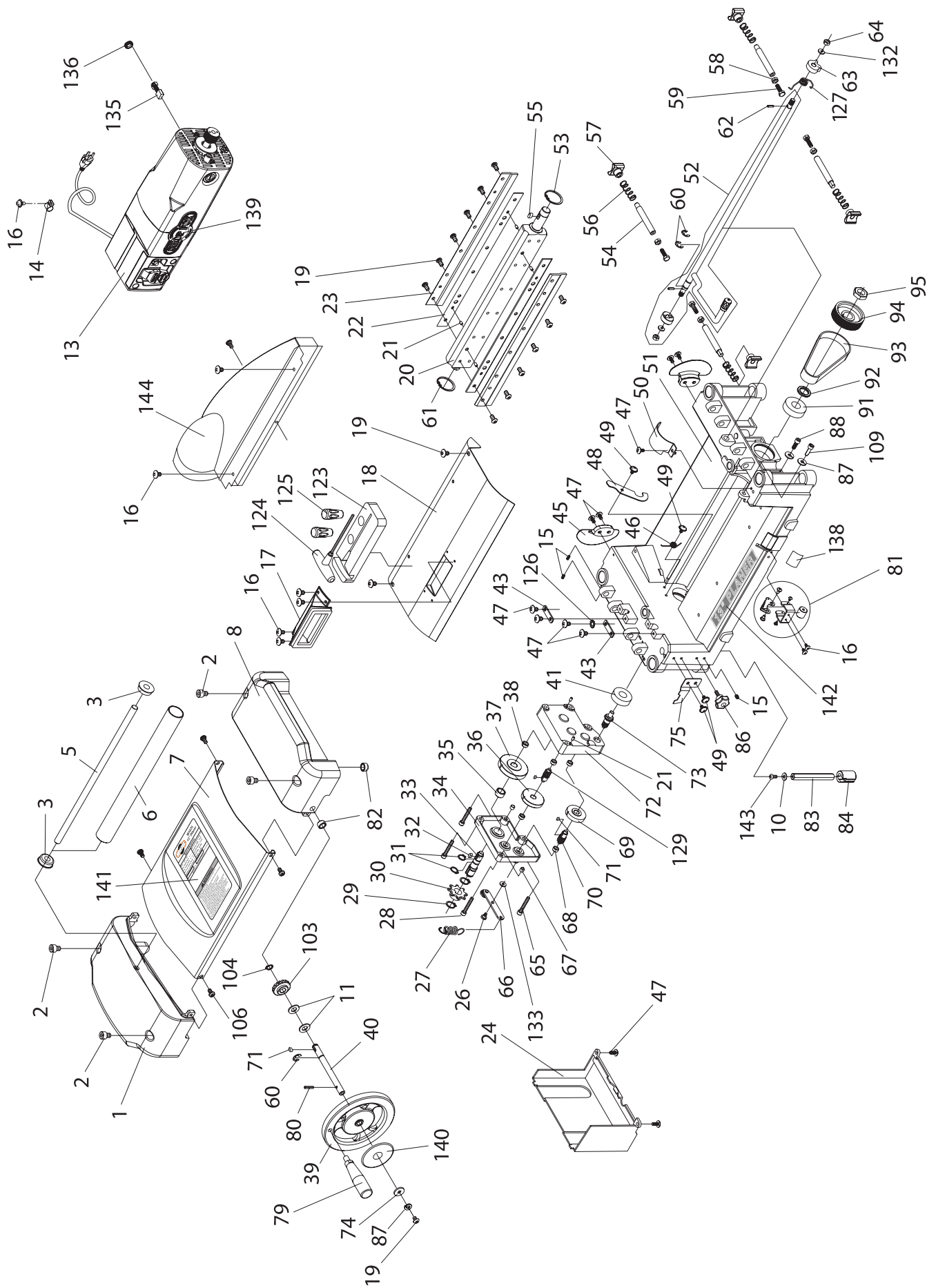

REF	PART #	DESCRIPTION
1	X1675001	LEFT COVER
2	XPSB11M	CAP SCREW M8-1.25 X 16
3	X1675003	BUSHING
4	XPS38M	PHLP HD SCR M4-0.7 X 10
5	X1675005	ROLLER SHAFT
6	X1675006	ROLLER
7	X1675007	TOP COVER
8	X1675008	RIGHT COVER
9	XPW09M	FLAT WASHER 13MM
10	XPW02M	FLAT WASHER 5MM
11	XPW04M	FLAT WASHER 10MM
12	XPSB14M	CAP SCREW M8-1.25 X 20
13	X1675013	MOTOR
14	X1675014	PIPE BAND
15	XPSS07M	SET SCREW M5-0.8 X 5
16	XPS07M	PHLP HD SCR M4-0.7 X 8
17	X1675017	DUST CHUTE
18	X1675018	CHIP DEFLECTOR PLATE
19	X1675019	BUTTON HD SCR M6-1 X 12
20	X1675020	CUTTERHEAD
21	X1675021	PIN
22	X1675022	KNIFE
23	X1675023	KNIFE BINDER
24	X1675024	CHAIN COVER
25	X1675025	SIDE COVER
26	X1675026	SPECIAL PIVOT SCREW
27	X1675027	SPRING
28	XPSB78M	CAP SCREW M5-0.8 X 40
29	XPR05M	EXT RETAINING RING 15MM
30	X1675030	SPROCKET
31	XPR03M	EXT RETAINING RING 12MM
32	XPK64M	KEY 5 X 5 X 9MM
33	X1675033	SHAFT
34	X1675034	GEAR BOX COVER
35	X1675035	BUSHING
36	X1675036	GEAR 44T
37	X1675037	GEAR 58T
38	X1675038	BUSHING
39	X1675039	HANDWHEEL
40	X1675040	SHAFT
41	XP6202	BEARING 6202
42	X1675042	CHAIN
43	X1675043	PLATE
44	XPSB04M	CAP SCREW M6-1.0 X 10
45	X1675045	BRACKET
46	X1675046	SPRING
47	XPS09M	PHLP HD SCREW M5-0.8 X10
48	X1675048	STABLE PLATE
49	XPS09M	PHLP HD SCREW M5-0.8 X10
50	X1675050	BELT GUARD

REF	PART #	DESCRIPTION
51	X1675051	TOP TABLE
52	X1675052	REAR ROD BRACKET
53	XPR34M	INT RETAINING RING 40MM
54	X1675054	SHAFT
55	XPK06M	KEY 5 X 5 X 10MM
56	X1675056	SPRING
57	X1675057	PAD
58	XPN06M	NUT M5-0.8
59	XPB79M	HEX HEAD SCREW M5-0.8 X 17
60	XPEC10M	E-CLIP 8MM
61	XPR21M	INT RETAINING RING 35MM
62	X1675062	SPRING PIN
63	X1675063	FIXING CAM
64	XPN03M	HEX NUT M8-1.25
65	XPSB78M	CAP SCREW M5-0.8 X 35
66	X1675066	TENSION WHEEL ASSEMBLY
67	X1675067	PIN
68	X1675068	BUSHING
69	X1675069	GEAR
70	X1675070	GEAR
71	XPK64M	KEY 4 X 4 X 7MM
72	X1675072	GEAR CASE ASSEMBLY
73	X1675073	GEAR
74	XPW03M	FLAT WASHER 6MM
75	X1675075	POINTER
76	XPN01M	HEX NUT M6-1.0
77	XPSB28M	CAP SCREW M6-1.0 X 15
78	X1675078	CHAIN
79	X1675079	HANDLE 1.5 X 24MM
80	XPRP39M	ROLL PIN 4 X 20MM
81	X1675081	POINTER
82	X1675082	BUSHING
83	X1675083	SHAFT
84	X1675084	THICKNESS GAUGE
85	X1675085	SPRING
86	X1675086	KNOB M6-1.0 X 17
87	X1675087	SPRING
88	XPSB06M	CAP SCREW M6-1.0 X 25
89	X1675089	SPRING
90	X1675090	ROLLER BRACKET
91	XP6203	BEARING 6203
92	X1675092	COLLAR
93	X1675093	BELT 135 X 6MM
94	X1675094	CUTTERHEAD PULLEY
95	X1675095	SPECIAL NUT M14-1.5
96	X1675096	BRACKET
97	X1675097	RUBBER ROLLER
98	X1675098	SPRING
99	X1675099	COLUMN

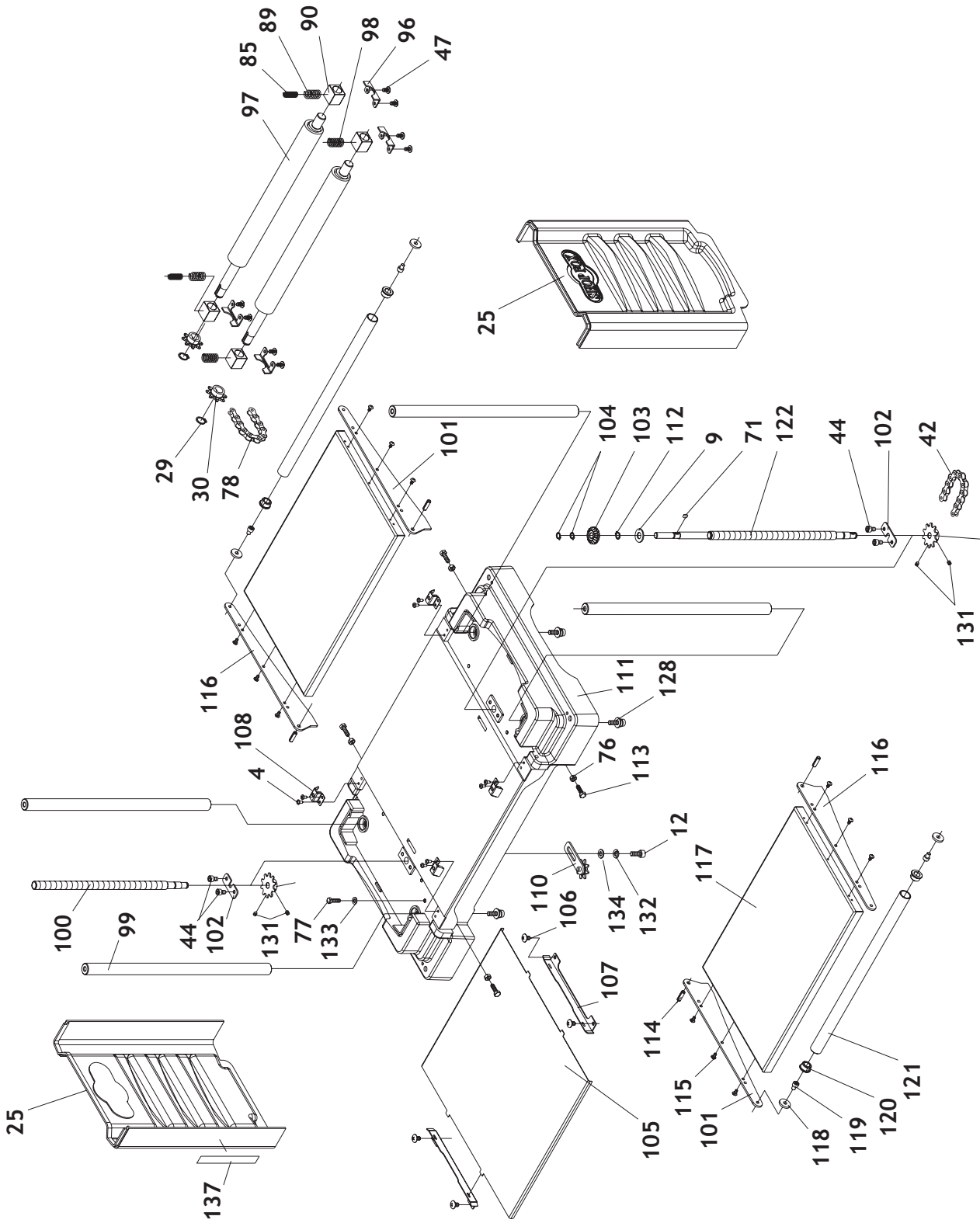



REF	PART #	DESCRIPTION	REF	PART #	DESCRIPTION
100	X1675100	SHORT LEAD SCREW	123	X1675123	TOOLING TRAY
101	X1675101	WING (LEFT)	124	X1675124	"T" ALLEN WRENCH 4MM
102	X1675102	PLATE	125	X1675125	KNIFE SETTING GAUGE
103	X1675103	GEAR	126	XPTLW02M	EXT-TOOTH WASHER 5MM
104	XPR01M	EXT RETAINING RING 10MM	127	X1675127	SPRING
105	X1675105	GASKET PLATE	128	X1675128	CAPTURED SCR M8-1.25 X 20/8
106	XPSB04M	PHLP HD SCREW M6-1 X 10	129	X1675129	GEAR
107	X1675107	GUIDE PLATE	130	X1675130	SPROCKET
108	X1675108	SPRING PLATE	131	XPSS01M	SET SCREW M6-1 X 10
109	XPHTK5M	TAP SCREW M6-1.59D X 20	132	XPLW04M	LOCK WASHER 8MM
110	X1675110	TENSION BRACKET ASSY	133	XPW03M	FLAT WASHER 6MM
111	X1675111	BASE	134	XPW01M	FLAT WASHER 8MM
112	XPR48	EXT RETAINING RING 11MM	135	X1675135	MOTOR BRUSH
113	XPSB06M	CAP SCREW M6-1 X 25	136	X1675136	BRUSH CAP
114	X1675114	SPRING PIN	137	X1675137	LABEL(SCALE)
115	XPSB18M	CAP SCREW M4-07 X 8	138	X1675138	LABEL (DEPTH SCALE)
116	X1675116	WING (RIGHT)	139	X1675139	LABEL (SHOP FOX®)
117	X1675117	EXTENSION WING	140	X1675140	LABEL (DEPTH SCALE)
118	X1675118	SPECIAL FLAT WASHER 6MM	141	X1675141	LABEL (WARNING)
119	XPSB28M	CAP SOCKET SCREW M6-1.0 X 15MM	142	X1675142	LABEL (13" PLANER)
120	X1675120	BUSHING	143	XPS09M	PHLP HD SCREW M5-0.8 X 10
121	X1675121	ROLLER	144	X1675144	DUST PORT
122	X1675122	LEAD SCREW (RIGHT)			



YOUR NOTES

YOUR NOTES

YOUR NOTES

WARRANTY CARD

Name _____
 Street _____
 City _____ State _____ Zip _____
 Phone Number _____ E-Mail _____ FAX _____
 MODEL # _____ Serial # _____

The following information is given on a voluntary basis and is strictly confidential.

CUT ALONG DOTTED LINE

1. Where did you purchase your SHOP FOX® machine?

2. How did you first learn about us?

<input type="checkbox"/> Advertisement	<input type="checkbox"/> Friend
<input type="checkbox"/> Mail order Catalog	<input type="checkbox"/> Local Store
<input type="checkbox"/> World Wide Web Site	
<input type="checkbox"/> Other _____	
3. Which of the following magazines do you subscribe to.

<input type="checkbox"/> American Woodworker	<input type="checkbox"/> Today's Homeowner
<input type="checkbox"/> Cabinetmaker	<input type="checkbox"/> Wood
<input type="checkbox"/> Family Handyman	<input type="checkbox"/> Wooden Boat
<input type="checkbox"/> Fine Homebuilding	<input type="checkbox"/> Woodshop News
<input type="checkbox"/> Fine Woodworking	<input type="checkbox"/> Woodsmith
<input type="checkbox"/> Home Handyman	<input type="checkbox"/> Woodwork
<input type="checkbox"/> Journal of Light Construction	<input type="checkbox"/> Woodworker
<input type="checkbox"/> Old House Journal	<input type="checkbox"/> Woodworker's Journal
<input type="checkbox"/> Popular Mechanics	<input type="checkbox"/> Workbench
<input type="checkbox"/> Popular Science	<input type="checkbox"/> American How-To
<input type="checkbox"/> Popular Woodworking	
<input type="checkbox"/> Other _____	
4. Which of the following woodworking/remodeling shows do you watch?

<input type="checkbox"/> Backyard America	<input type="checkbox"/> The New Yankee Workshop
<input type="checkbox"/> Home Time	<input type="checkbox"/> This Old House
<input type="checkbox"/> The American Woodworker	<input type="checkbox"/> Woodwright's Shop
<input type="checkbox"/> Other _____	
5. What is your annual household income?

<input type="checkbox"/> \$20,000-\$29,999	<input type="checkbox"/> \$60,000-\$69,999
<input type="checkbox"/> \$30,000-\$39,999	<input type="checkbox"/> \$70,000-\$79,999
<input type="checkbox"/> \$40,000-\$49,999	<input type="checkbox"/> \$80,000-\$89,999
<input type="checkbox"/> \$50,000-\$59,999	<input type="checkbox"/> \$90,000 +
6. What is your age group?

<input type="checkbox"/> 20-29	<input type="checkbox"/> 50-59
<input type="checkbox"/> 30-39	<input type="checkbox"/> 60-69
<input type="checkbox"/> 40-49	<input type="checkbox"/> 70 +
7. How long have you been a woodworker?

<input type="checkbox"/> 0 - 2 Years	<input type="checkbox"/> 8 - 20 Years
<input type="checkbox"/> 2 - 8 Years	<input type="checkbox"/> 20+ Years
8. How would you rank your woodworking skills?

<input type="checkbox"/> Simple	<input type="checkbox"/> Advanced
<input type="checkbox"/> Intermediate	<input type="checkbox"/> Master Craftsman
9. How many SHOP FOX® machines do you own? _____
10. What stationary woodworking tools do you own? Check all that apply.

<input type="checkbox"/> Air Compressor	<input type="checkbox"/> Panel Saw
<input type="checkbox"/> Band Saw	<input type="checkbox"/> Planer
<input type="checkbox"/> Drill Press	<input type="checkbox"/> Power Feeder
<input type="checkbox"/> Drum Sander	<input type="checkbox"/> Radial Arm Saw
<input type="checkbox"/> Dust Collector	<input type="checkbox"/> Shaper
<input type="checkbox"/> Horizontal Boring Machine	<input type="checkbox"/> Spindle Sander
<input type="checkbox"/> Jointer	<input type="checkbox"/> Table Saw
<input type="checkbox"/> Lathe	<input type="checkbox"/> Vacuum Veneer Press
<input type="checkbox"/> Mortiser	<input type="checkbox"/> Wide Belt Sander
<input type="checkbox"/> Other _____	
11. Which benchtop tools do you own? Check all that apply.

<input type="checkbox"/> 1" x 42" Belt Sander	<input type="checkbox"/> 6" - 8" Grinder
<input type="checkbox"/> 5" - 8" Drill Press	<input type="checkbox"/> Mini Lathe
<input type="checkbox"/> 8" Table Saw	<input type="checkbox"/> 10" - 12" Thickness Planer
<input type="checkbox"/> 8" - 10" Bandsaw	<input type="checkbox"/> Scroll Saw
<input type="checkbox"/> Disc/Belt Sander	<input type="checkbox"/> Spindle/Belt Sander
<input type="checkbox"/> Mini Jointer	
<input type="checkbox"/> Other _____	
12. Which portable/hand held power tools do you own? Check all that apply.

<input type="checkbox"/> Belt Sander	<input type="checkbox"/> Orbital Sander
<input type="checkbox"/> Biscuit Joiner	<input type="checkbox"/> Palm Sander
<input type="checkbox"/> Circular Saw	<input type="checkbox"/> Portable Planer
<input type="checkbox"/> Detail Sander	<input type="checkbox"/> Saber Saw
<input type="checkbox"/> Drill/Driver	<input type="checkbox"/> Reciprocating Saw
<input type="checkbox"/> Miter Saw	<input type="checkbox"/> Router
<input type="checkbox"/> Other _____	
13. What machines/supplies would you like to see?

14. What new accessories would you like Woodstock International to carry?

15. Do you think your purchase represents good value?

<input type="checkbox"/> Yes	<input type="checkbox"/> No
------------------------------	-----------------------------
16. Would you recommend SHOP FOX® products to a friend?

<input type="checkbox"/> Yes	<input type="checkbox"/> No
------------------------------	-----------------------------
17. Comments: _____

FOLD ALONG DOTTED LINE

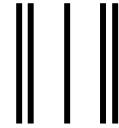
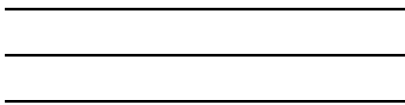

Place
Stamp
Here



WOODSTOCK INTERNATIONAL, INC.
P.O. BOX 2309
BELLINGHAM, WA 98227-2309



FOLD ALONG DOTTED LINE

TAPE ALONG EDGES--PLEASE DO NOT STAPLE

