

PARTS MANUAL



***WHITEMAN* SERIES**
MODEL WM-90S (STEEL)
MODEL WM-90P (PLASTIC)
PLASTER AND MORTAR MIXER
(GASOLINE ENGINE/ELECTRIC MOTOR)

Revision #6 (03/04/08)

To find the latest revision of this
publication, visit our website at:
www.multiquip.com



THIS MANUAL MUST ACCOMPANY THE EQUIPMENT AT ALL TIMES.



WARNING



CALIFORNIA — Proposition 65 Warning

Engine exhaust and some of its constituents, and some dust created by power sanding, sawing, grinding, drilling and other construction activities contains chemicals known to the State of California to cause cancer, birth defects and other reproductive harm. Some examples of these chemicals are:

- Lead from lead-based paints.
- Crystalline silica from bricks.
- Cement and other masonry products.
- Arsenic and chromium from chemically treated lumber.

Your risk from these exposures varies, depending on how often you do this type of work. To reduce your exposure to these chemicals: **ALWAYS** work in a well ventilated area, and work with approved safety equipment, such as dust masks that are specially designed to filter out microscopic particles.

WM-90 S/P PLASTER/MORTAR MIXER — TABLE OF CONTENTS

MQ-WHITEMAN — WM-90S/P

Plaster/Mortar Mixer

Here's How To Get Help	2
Table Of Contents	3
Parts Ordering Procedures	4
Explanation of Code In Remarks Column	6
Suggested Spare Parts	7

Component Drawings

Nameplate and Decals	8-9
Frame Assembly	10-11
Paddle Shaft Assembly	12-13
Steel Drum Assembly	14-15
Plastic Drum Assembly	16-17
Drum & Paddle Shaft Complete Assy. (Poly)	18-19
Drum & Paddle Shaft Complete Assy. (Steel) ...	20-21
Axle Assembly	22-23
Engine Assembly	24-25
Electric Motor Assembly	26-27
Cabinet Assembly	28-29

HONDA GX240K1HA2 ENGINE

Air Cleaner Assembly	30-31
Camshaft Assembly	32-33
Carburetor Assembly	34-35
Control Assembly	36-37
Crankcase Cover Assembly	38-39
Crankshaft Assembly	40-41
Cylinder Barrel Assembly	42-43
Cylinder Head Assembly	44-45
Fan Cover Assembly	46-47
Flywheel Assembly	48-49
Muffler Assembly	50-51
Fuel Tank Assembly	52-53
Ignition Coil	54-55
Piston Assembly	56-57
Recoil Starter	58-59
Gear Reduction Assembly	60-61
Label Assembly	62-63

Terms and Conditions of Sale — Parts	64
--------------------------------------------	----

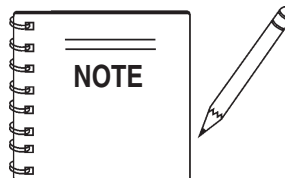

**Specifications and are
subject to change
without notice.**

PARTS ORDERING PROCEDURES

Ordering parts has never been easier! Choose from three easy options:

Effective:
January 1st, 2006



Order via Internet (Dealers Only):

Order parts on-line using Multiquip's SmartEquip website!

- View Parts Diagrams
- Order Parts
- Print Specification Information



If you have an MQ Account, to obtain a Username and Password, E-mail us at: parts@multiquip.com.

To obtain an MQ Account, contact your District Sales Manager for more information.

Goto www.multiquip.com and click on **Order Parts** to log in and save!

Use the **internet** and qualify for a **5% Discount** on *Standard orders* for all orders which include complete part numbers.*

Note: Discounts Are Subject To Change



Order via Fax (Dealers Only):

All customers are welcome to order parts via Fax.

Domestic (US) Customers dial:
1-800-6-PARTS-7 (800-672-7877)

Fax your order in and qualify for a **2% Discount** on *Standard orders* for all orders which include complete part numbers.*

Note: Discounts Are Subject To Change



Order via Phone: Domestic (US) Dealers Call:
1-800-427-1244

Non-Dealer Customers:

Contact your local Multiquip Dealer for parts or call 800-427-1244 for help in locating a dealer near you.



International Customers should contact their local Multiquip Representatives for Parts Ordering information.

When ordering parts, please supply:

- | | |
|-------------------------------------------------------------------------------|----------------------------------------------------------------------------------------|
| <input type="checkbox"/> Dealer Account Number | <input type="checkbox"/> Specify Preferred Method of Shipment: |
| <input type="checkbox"/> Dealer Name and Address | <input checked="" type="checkbox"/> UPS/Fed Ex <input checked="" type="checkbox"/> DHL |
| <input type="checkbox"/> Shipping Address (if different than billing address) | <input type="checkbox"/> Priority One <input checked="" type="checkbox"/> Truck |
| <input type="checkbox"/> Return Fax Number | <input type="checkbox"/> Ground |
| <input type="checkbox"/> Applicable Model Number | <input type="checkbox"/> Next Day |
| <input type="checkbox"/> Quantity, Part Number and Description of Each Part | <input type="checkbox"/> Second/Third Day |

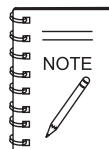

All orders are treated as *Standard Orders* and will ship the same day if received prior to 3PM PST.

WE ACCEPT ALL MAJOR CREDIT CARDS!



www.multiquip.com



EXPLANATION OF CODE IN REMARKS COLUMN

The following section explains the different symbols and remarks used in the Parts section of this manual. Use the help numbers found on the back page of the manual if there are any questions.

The contents and part numbers listed in the parts section are subject to change **without notice**. Multiquip does not guarantee the availability of the parts listed.

Sample Parts List:

NO.	PART NO.	PART NAME	QTY.	REMARKS
1	12345	BOLT	1	INCLUDES ITEMS W/*
2*		WASHER, 1/4 IN.		NOT SOLD SEPARATELY
2*	12347	WASHER, 3/8 IN. ... 1		MQ-45T ONLY
3	12348	HOSE	A/R	MAKE LOCALLY
4	12349	BEARING	1	S/N 2345B AND ABOVE

NO. Column

Unique Symbols - All items with same unique symbol (*, #, +, %, or >) in the number column belong to the same assembly or kit, which is indicated by a note in the "Remarks" column.

Duplicate Item Numbers - Duplicate numbers indicate multiple part numbers are in effect for the same general item, such as different size saw blade guards in use or a part that has been updated on newer versions of the same machine.



When ordering a part that has more than one item number listed, check the remarks column for help in determining the proper part to order.

PART NO. Column

Numbers Used - Part numbers can be indicated by a number, a blank entry, or TBD.

TBD (To Be Determined) is generally used to show a part that has not been assigned a formal part number at time of publication.

A blank entry generally indicates that the item is not sold separately or is not sold by Multiquip. Other entries will be clarified in the "Remarks" Column.

QTY. Column

Numbers Used - Item quantity can be indicated by a number, a blank entry, or A/R.

A/R (As Required) is generally used for hoses or other parts that are sold in bulk and cut to length.

A blank entry generally indicates that the item is not sold separately. Other entries will be clarified in the "Remarks" Column.

REMARKS Column

Some of the most common notes found in the "Remarks" Column are listed below. Other additional notes needed to describe the item can also be shown.

Assembly/Kit - All items on the parts list with the same unique symbol will be included when this item is purchased.

Indicated by:

"INCLUDES ITEMS W/(unique symbol)"

Serial Number Break - Used to list an effective serial number range where a particular part is used.

Indicated by:

"S/N XXXXX AND BELOW"

"S/N XXXX AND ABOVE"

"S/N XXXX TO S/N XXXX"

Specific Model Number Use - Indicates that the part is used only with the specific model number or model number variant listed. It can also be used to show a part is NOT used on a specific model or model number variant.

Indicated by:

"XXXXX ONLY"

"NOT USED ON XXXX"

"Make/Obtain Locally" - Indicates that the part can be purchased at any hardware shop or made out of available items. Examples include battery cables, shims, and certain washers and nuts.

"Not Sold Separately" - Indicates that an item cannot be purchased as a separate item and is either part of an assembly/kit that can be purchased, or is not available for sale through Multiquip.

WM-90S/P MIXER — SUGGESTED SPARE PARTS

WM-90P/S PLASTER AND MORTAR MIXER 1 TO 3 UNITS WITH HONDA GX240K1HA2 ENGINE

Qty...	P/N	Description
6	505834	V-BELT A36 HONDA ENGINE
6	491112	V-BELT A40 ELECTRIC MOTOR
2	EM914288	OIL SEAL, AXLE
4	EM903113	BEARING, CONE, AXLE
4	EM903112	BEARING, CUP, AXLE
2	20654-001	SEAL, PADDLE SHAFT (BLACK)
2	530029	RING, RETENTION
2	20104-002	SEAL, SHAFT URETHANE (YELLOW)
3	17210ZE2515	ELEMENT, AIR CLEANER
3	9807956846	SPARK PLUG
1	28462ZE2W11	ROPE, RECOIL STARTER
1	17620ZH7023	CAP, FUEL TANK
2	EM200863	KIT, WIPER BLADES (STEEL DRUM)
2	EM204625	KIT, WIPER BLADES (PLASTIC DRUM)

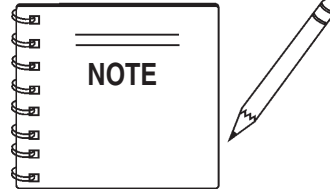

Part numbers on this Suggested Spare Parts List may supercede/replace the P/N's shown in the test pages of this manual.

WM-90S/P MIXER — NAMEPLATE AND DECALS

NAMEPLATE AND DECALS

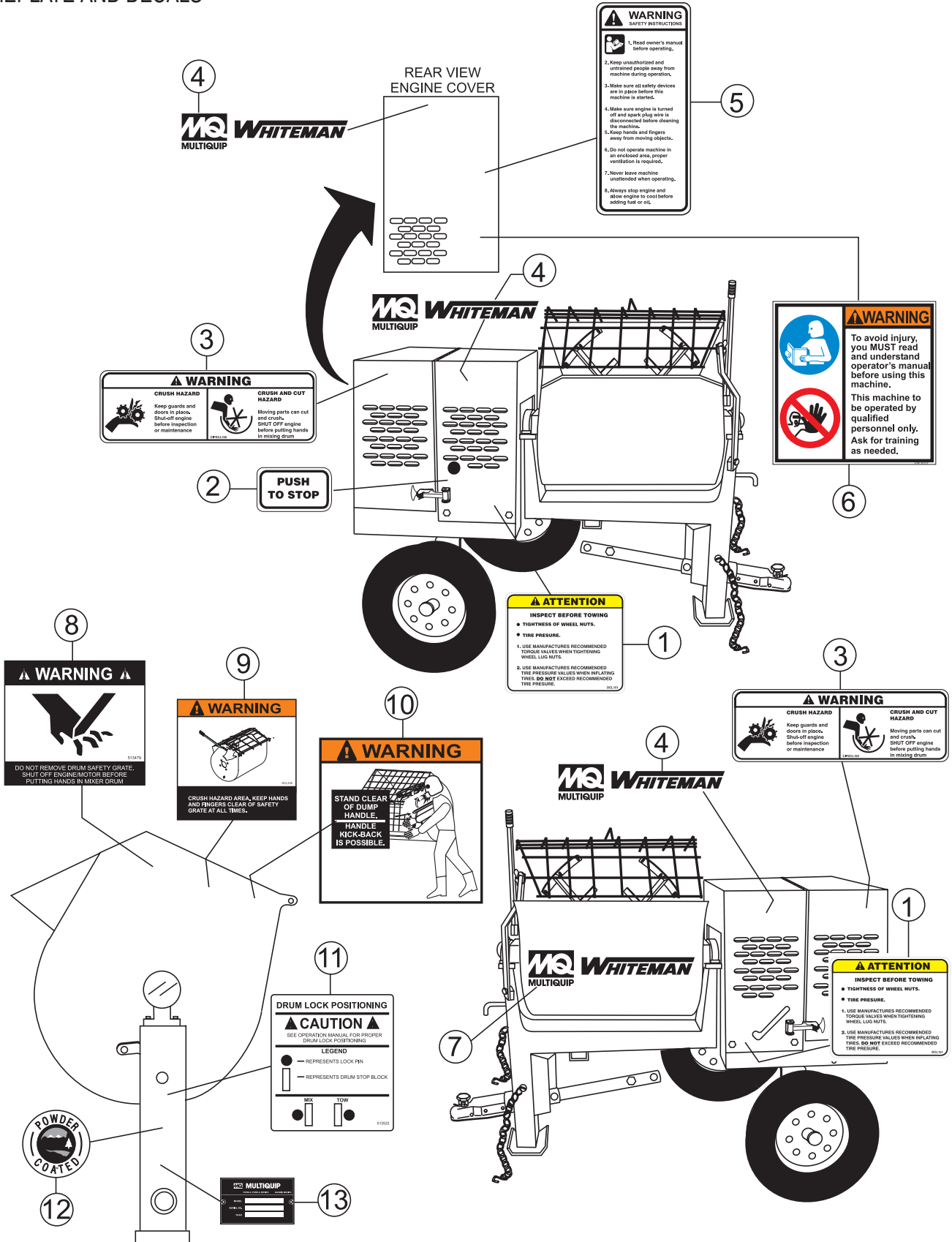

WM-90S/P MIXER — NAMEPLATE AND DECALS

NAMEPLATE AND DECALS

<u>NO</u>	<u>PART NO</u>	<u>PART NAME</u>	<u>QTY.</u>	<u>REMARKS</u>
1	DCL151	DECAL, TOWING INSTRUCTIONS	2	
2	EM948630	DECAL, PUSH TO STOP	1	
3	CIPDCL160	DECAL, CRUSH WARNING	2	
4	515275	DECAL, WHITEMAN LOGO (SMALL)	3	
5	504713	DECAL, SAFETY INSTRUCTIONS	1	
6	35137	DECAL, WARNING READ	1	
7	504714	DECAL, WHITEMAN LOGO (LARGE)	3	
9	513479	DECAL, WARNING SAFETY GRATE	1	
9	DCL335	DECAL, CRUSH WARNING SAFETY GRATE	1	
10	DCL280	DECAL, WARNING DUMP HANDLE	1	
11	513522	DECAL, DRUM LOCK	1	
12	13118	DECAL, POWDER COATED	1	
13		NAMEPLATE	1 CONTACT PARTS DEPT.

WM-90S/P MIXER — FRAME ASSY.

FRAME ASSY.

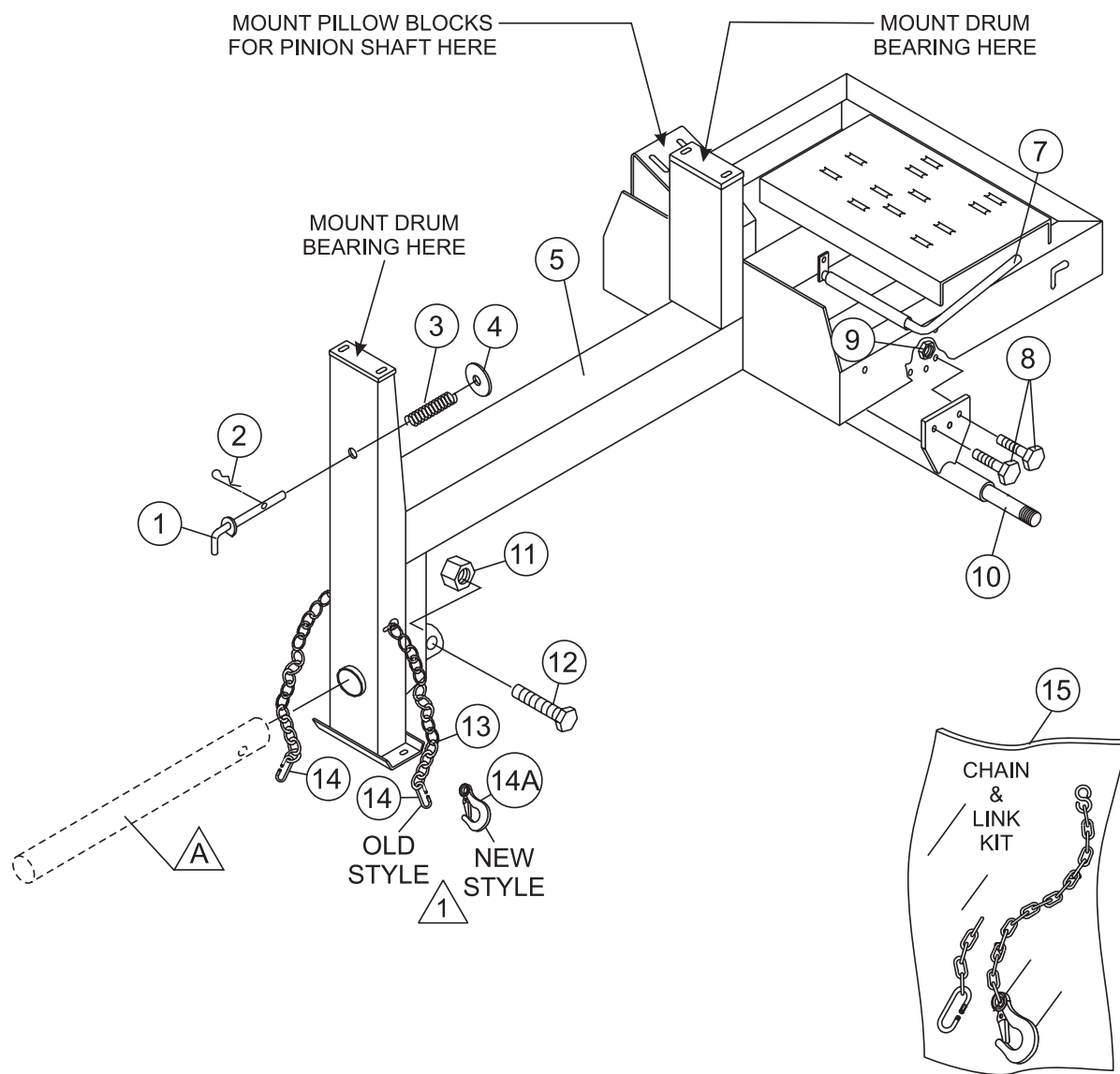

A OPTIONAL TOW BARS

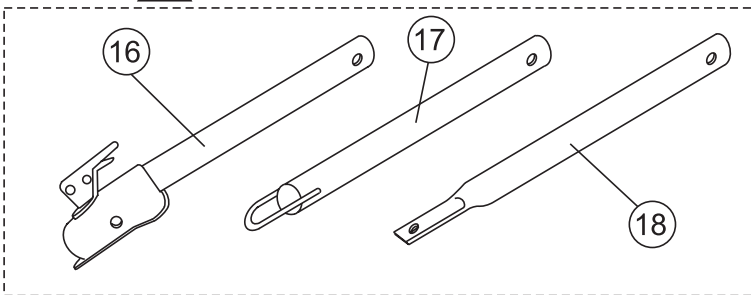

Quantity of item 14, Connector Link, changed from 2 to 1 in January 2006. Item 14A, Clevis Safety Hook, replaces discontinued Connector Link.



WM-90S/P MIXER — FRAME ASSY.

FRAME ASSY.

<u>NO.</u>	<u>PART NO.</u>	<u>PART NAME</u>	<u>QTY.</u>	<u>REMARKS</u>
1	514842	LOCK PIN UNIT	1	
2	491692	COTTER PIN	1	
3	530023	SPRING LOCKING PIN	1	
4	507444	WASHER, FLAT 3/4"	1	
5	514835	MAIN FRAME	1	
8	EM963692	BOLT 1/2" UNC 1-1/2"	6	
9	492584	NUT, LOCK 1/2"	6	
10	514802	AXLE, UNIVERSAL	1	
11	10176	LOCK NUT 1/2" NC	1	
12	EM124	BOLT 1/2"-13 X 4 G5	1	
13*		SAFETY CHAIN	1	
14*	01004	CONNECTOR LINK	2	BEFORE JANUARY 2006
14*	01004	CONNECTOR LINK	1	AFTER JANUARY 2006
14A*	516580	CLEVIS SAFETY HOOK	1	AFTER JANUARY 2006
15	13363KIT	CHAIN AND LINK KIT	1	INCLUDES ITEMS W/*
16	HBC-1	BALL HITCH 2-INCH	1	CONTACT UNIT SALES
17	HLC-1	LOOP HITCH	1	CONTACT UNIT SALES
18	HPC-1	PIN HITCH 1-INCH	1	CONTACT UNIT SALES

WM-90S/P MIXER — PADDLE SHAFT ASSY.

PADDLE SHAFT ASSY.

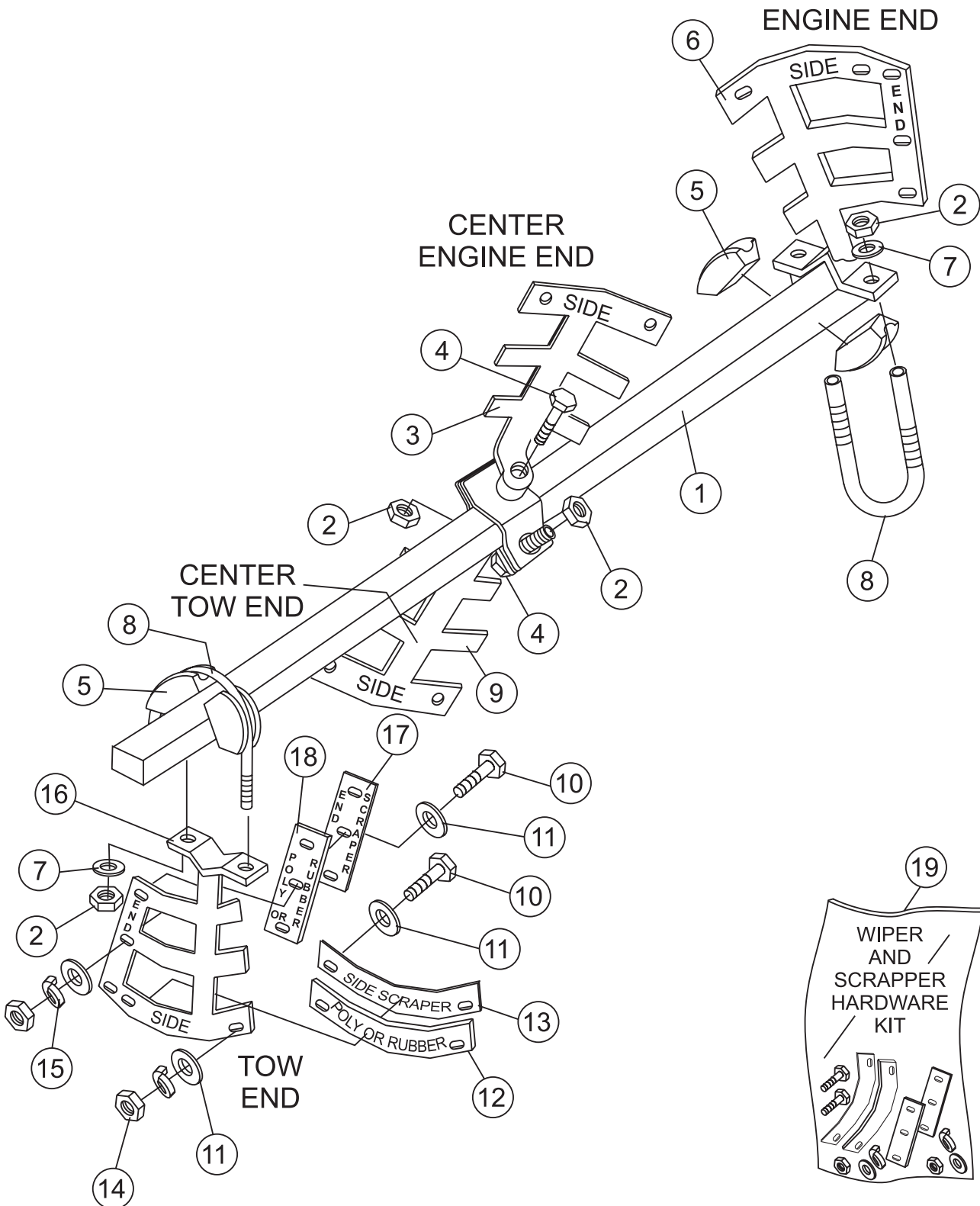

WM-90S/P MIXER — PADDLE SHAFT ASSY.

PADDLE SHAFT ASSY.

<u>NO.</u>	<u>PART NO.</u>	<u>PART NAME</u>	<u>QTY.</u>	<u>REMARKS</u>
1	514752	PADDLE SHAFT	1	
2	492584	NUT, LOCK 1/2"	6	
3	EM200295	PADDLE ARM, CENTER ENGINE END	1	
4	510721	BOLT, 1/2 " X 6" G5	2	
5	EM200292	INSERT, PADDLE ARM	4	
6	EM200296	PADDLE ARM, ENGINE END	1	
7	504322	WASHER, FLAT 1/2"	6	
8	EM200297	U-BOLT, END PADDLES	2	
9	EM200294	PADDLE ARM, CENTER TOW END	1	
10*#	492367	SCREW, HHC 5/16-18 X 1-3/4 G5	14	
11*#	EM923023	WASHER, FLAT 5/16"	28	
12#	EM507519	BLADE, SIDE, POLY	4	PLASTIC DRUM
12*	EM200212	BLADE, SIDE, RUBBER	4	STEEL DRUM
13*#	EM203432	BLADE, SIDE, SCRAPPER	4	STEEL & PLASTIC DRUM
14*#	2105164	NUT, HEX 5/16" NC G5	14	
15*#	EM923343	WASHER, LOCK 5/15"	14	
16	EM200293	PADDLE ARM, TOW END	1	
17*#	EM203433	BLADE ,SCRAPPER END	4	STEEL & PLASTIC DRUM
18#	EM507518	BLADE, PLASTIC END	4	PLASTIC DRUM
18*	EM200213	BLADE, RUBBER END	4	STEEL DRUM
19	EM200863	KIT, WIPERS, SCRAPPERS & HDWARE	1	INCLUDES ITEMS W/* STEEL DRUM
19	EM204625	KIT, WIPERS, SCRAPPERS & HDWARE	1	INCLUDES ITEMS W/# PLASTIC DRUM

WM-90S/P MIXER — STEEL DRUM ASSY.

STEEL DRUM ASSY.

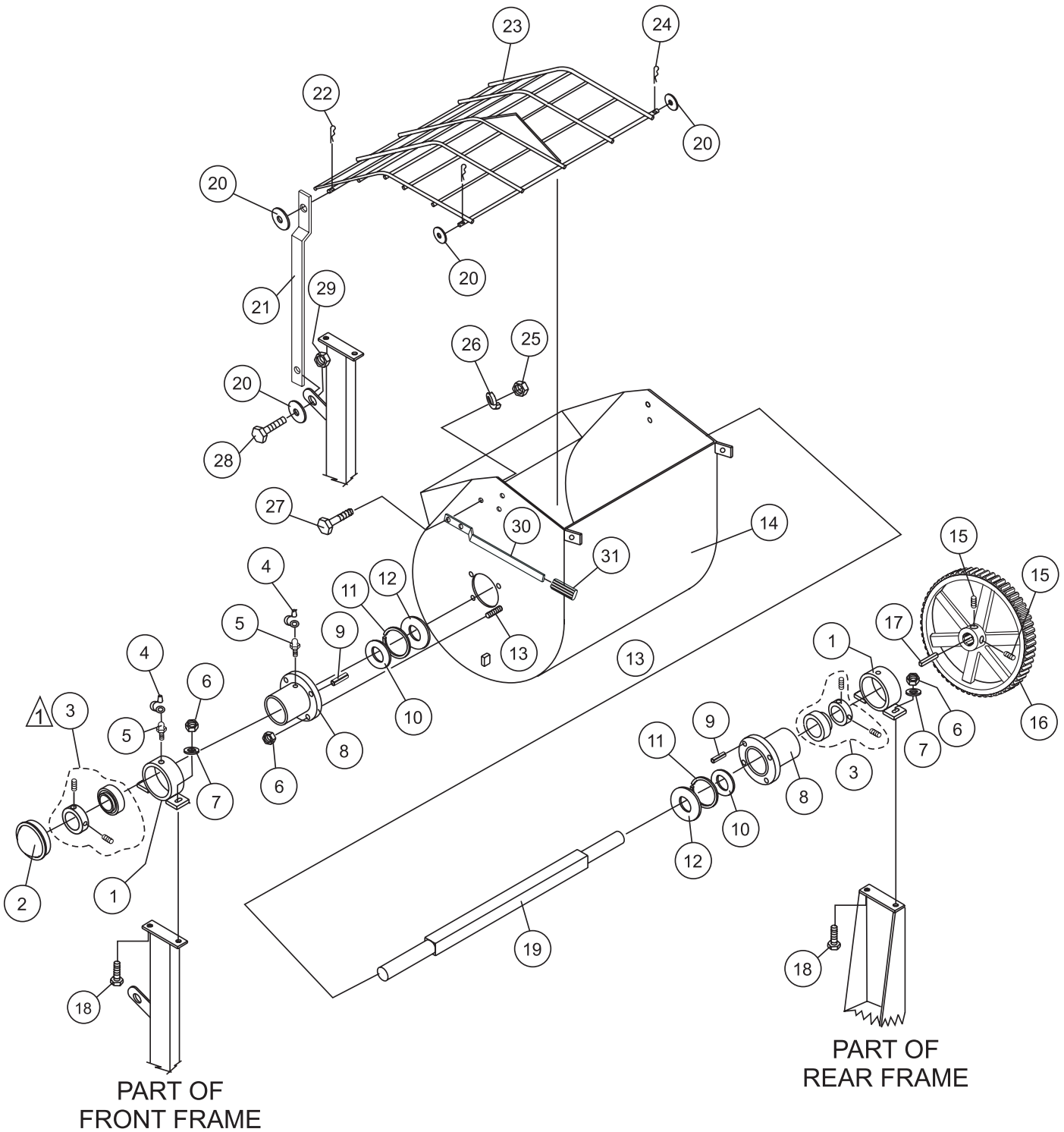

NOTES:

- ⚠ SET SCREWS AND BEARING COLLAR ARE INCLUDED WITH BEARING AND CANNOT BE PURCHASED SEPARATELY.

WM-90S/P MIXER — STEEL DRUM ASSY.

STEEL DRUM ASSY.

<u>NO.</u>	<u>PART NO.</u>	<u>PART NAME</u>	<u>QTY.</u>	<u>REMARKS</u>
1	530028	DRUM BEARING BRACKET	2	
2	3249	CAP, DUST	1	
3	20561-001	BEARING SEALED	2	SET SCREWS AND BEARING COLLAR CANNOT BE PURCHASED SEPARATELY.
4	491008	CAP, GREASE FITTING	2	
5	EM916019	FITTING, GREASE	2	
6	EM969013	NUT, LOCK 3/8"	12	
7	3019092	WASHER, FLAT 3/8"	4	
8	514778	TRUNNION HUB	2	
9	513453	ROLL PIN 3/16" X 3/4"	2	
10	20654-001	SEAL, SHAFT (BLACK)	2	
11	530029	RING, RETENTION	2	
12	20104-002	SEAL, SHAFT URETHANE (YELLOW)	2	
13	504943	BOLT, FHCS 3/8" NC X 2" G5	8	
14	514786	DRUM, STEEL	1	
15	492484	SET SCREW	2	
16	530043	MAIN GEAR	1	
17	501016	KEY, 3/8" X 88 MM	1	
18	17985-012	CARRIAGE BOLT 3/8-16 X 1-1/2"	4	
19	514752	SHAFT, PADDLE	1	
20	492600	WASHER, FLAT 1/2"	4	
21	514945	LIFT BAR	1	
22	EM925191	PIN, COTTER	1	
23	514946	GRATE	1	
24	505070	PIN, COTTER	2	
25	492556	HEX NUT 1/2" G5	2	
26	6109180	WASHER, LOCK 1/2"	2	
27	EM963692	BOLT 1/2" UNC 1-1/2"	2	
28	EM963102	CAPSCREW, HHCS 1/2" NC X 1-1/4"	1	
29	492584	NUT, LOCK 1/2" NC	1	
30	201537	HANDLE DUMP	1	
31	EM98195	GRIP, DUMP HANDLE	1	

WM-90S/P MIXER — PLASTIC DRUM ASSY.

PLASTIC DRUM ASSY.

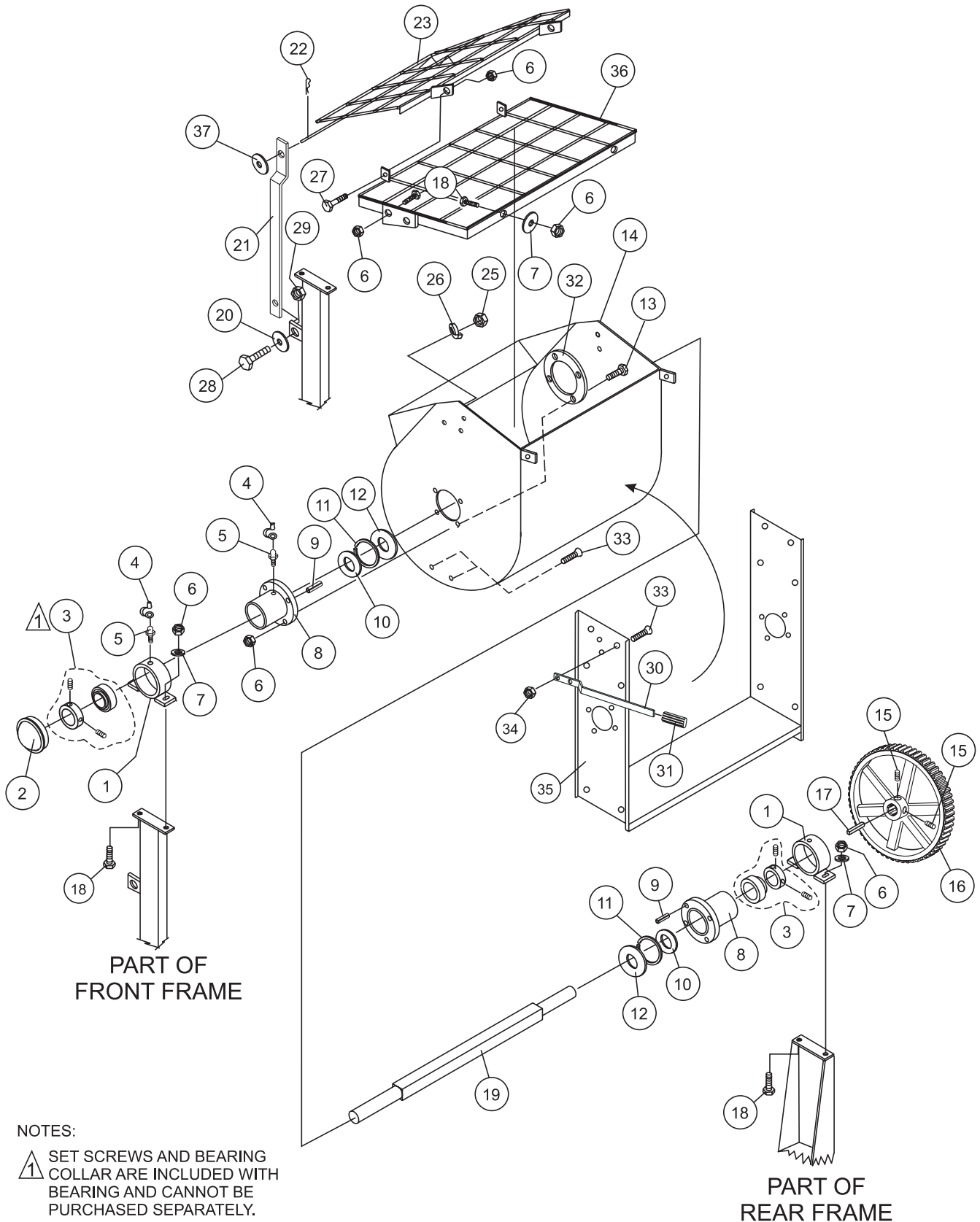

WM-90S/P MIXER — PLASTIC DRUM ASSY.

PLASTIC DRUM ASSY.

<u>NO.</u>	<u>PART NO.</u>	<u>PART NAME</u>	<u>QTY.</u>	<u>REMARKS</u>
1	530028	DRUM BEARING BRACKET	2	
2	3249	CAP, DUST	1	
3	20561-001	BEARING SEALED	2	SET SCREWS AND BEARING COLLAR CANNOT BE PURCHASED SEPARATELY.
4	491008	CAP, GREASE FITTING	2	
5	EM916019	FITTING, GREASE	2	
6	EM969013	NUT, LOCK 3/8"	20	
7	3019092	WASHER, FLAT 3/8"	6	
8	514778	TRUNNION HUB	2	
9	513453	ROLL PIN 3/16" X 3/4"	2	
10	20654-001	SEAL, SHAFT (BLACK)	2	
11	530029	RING, RETENTION	2	
12	20104-002	SEAL, SHAFT URETHANE (YELLOW)	2	
13	504943	BOLT, FHCS 3/8" NC X 2" G5	8	
14	515052	DRUM, PLASTIC	1	
15	492484	SET SCREW	2	
16	530043	MAIN GEAR	1	
17	500432	KEY, 3/8" X 88 MM	1	
18	17985-012	CARRIAGE BOLT 3/8-16 X 1-1/2"	4	
19	514752	SHAFT, PADDLE	1	
20	492600	WASHER, FLAT 1/2"	1	
21	514947	LIFT BAR	1	
22	EM925191	PIN, COTTER	1	
23	EM507417	GRATE, MOVEABLE	1	
24	505070	PIN, COTTER	2	
25	492556	HEX NUT 1/2" G5	2	
26	6109180	WASHER, LOCK 1/2"	2	
27	EM963610	BOLT 3/8" NC 1-1/4" G8	2	
28	EM963102	CAPSCREW, HHCS 1/2" NC X 1-1/4"	1	
29	492584	NUT, LOCK 1/2" NC	1	
30	EM201537	HANDLE DUMP	1	
31	EM98195	GRIP, DUMP HANDLE	1	
32	515033	RUBBER, GASKET	1	
33	511910	BOLT 1/4" NC X 1-1/4" G5	8	
34	2101428	NUT 1/4" NC	8	
35	514989	U-SUPPORT PLASTIC DRUM	1	
36	EM507416	GRATE, STATIONARY	1	
37	0401450160	WASHER, FLAT 5/8"	1	

WM-90 S/P MIXER — DRUM & PADDLE SHAFT COMPLETE ASSY.

DRUM AND PADDLE SHAFT COMPLETE ASSY. (PLASTIC DRUM)

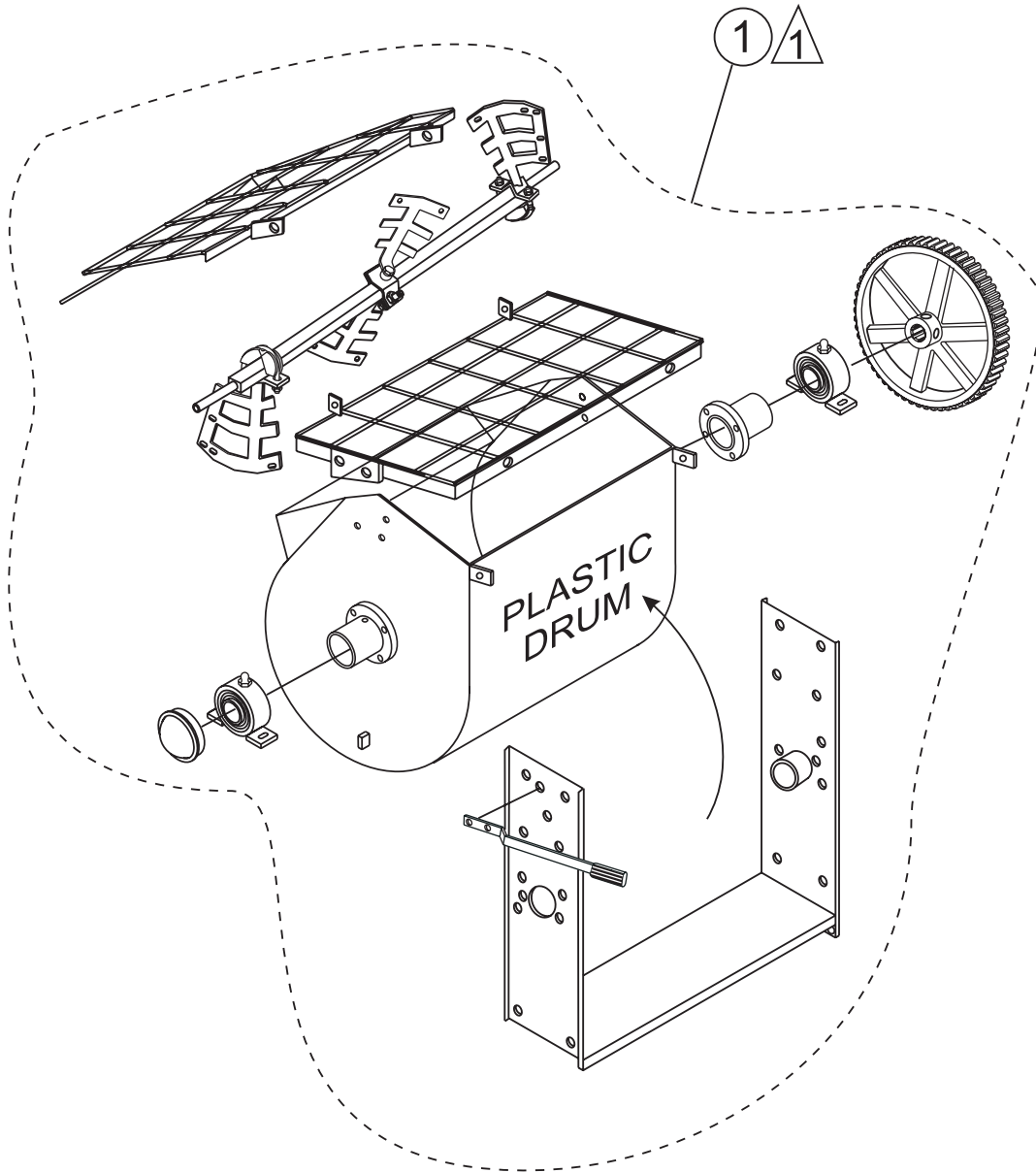

NOTES:

- △ 1 COMPLETE DRUM AND PADDLE SHAFT ASSEMBLIES ARE INCLUDED WITHIN DASHED LINES.

WM-90 S/P MIXER — DRUM & PADDLE SHAFT COMPLETE ASSY.

DRUM AND PADDLE SHAFT COMPLETE ASSY. (PLASTIC DRUM)

<u>NO.</u>	<u>PART NO.</u>	<u>PART NAME</u>	<u>QTY.</u>	<u>REMARKS</u>
1	516064	DRUM AND SHAFT COMPLETE ASSY.	1	INCLUDES ITEMS LISTED BELOW:
	530028	DRUM BEARING BRACKET	2	
	3249	CAP, DUST	1	
	20561-001	BEARING SEALED	2	
	491008	CAP, GREASE FITTING	2	
	EM916019	FITTING, GREASE	2	
	EM969013	NUT, LOCK 3/8"	20	
	3019092	WASHER, FLAT 3/8"	6	
	514754	TRUNNION HUB	2	
	513453	ROLL PIN 3/16" X 3/4"	2	
	20654-001	SEAL, SHAFT (BLACK)	2	
	530029	RING, RETENTION	2	
	20104-002	SEAL, SHAFT URETHANE (YELLOW)	2	
	513452	BOLT 3/8" NC X 1/4" G5	8	
	515052	DRUM, PLASTIC	1	
	492484	SET SCREW	2	
	530043	MAIN GEAR	1	
	500432	KEY, 3/8" X 50 MM	1	
	EM963057	CAPSCREW HHCS 3/8 X 1-1/2"	4	
	514752	SHAFT, PADDLE	1	
	EM507417	GRATE, MOVEABLE	1	
	505070	PIN, COTTER	2	
	492556	HEX NUT 1/2" G5	2	
	6109180	WASHER, LOCK 1/2"	2	
	EM963610	BOLT 3/8" NC 1-1/4" G8	2	
	EM201537	HANDLE, DUMP	1	
	15081	GRIP, DUMP HANDLE	1	
	515033	RUBBER, GASKET	1	
	511910	BOLT 1/4" NC X 1-1/4" G5	8	
	2101428	NUT 1/4" NC	8	
	514989	U-SUPPORT PLASTIC DRUM	1	
	EM507416	GRATE, STATIONARY	1	
	514752	PADDLE SHAFT	1	
	492584	NUT, LOCK 1/2"	6	
	EM200295	PADDLE ARM, CENTER ENGINE END	1	
	510721	BOLT, 1/2 " X 6" G5	2	
	EM200292	INSERT, PADDLE ARM	4	
	EM200296	PADDLE ARM, ENGINE END	1	
	504322	WASHER, FLAT 1/2"	6	
	EM200297	U-BOLT, END PADDLES	2	
	EM200294	PADDLE ARM, CENTER TOW END	1	
	492367	SCREW, HHC 5/16-18 X 1-3/4 G5	14	
	EM923023	WASHER, FLAT 5/16"	28	
	13352	BLADE, SIDE, POLY	4	
	EM203432	BLADE, SIDE, SCRAPPER	4	
	2105164	NUT, HEX 5/16" NC G5	14	
	EM923343	WASHER, LOCK 5/15"	14	
	EM200293	PADDLE ARM, TOW END	1	
	EM203433	BLADE ,SCRAPPER END	4	
	507518	BLADE, PLASTIC END	4	

WM-90 S/P MIXER — DRUM & PADDLE SHAFT COMPLETE ASSY.

DRUM AND PADDLE SHAFT COMPLETE ASSY. (STEEL DRUM)

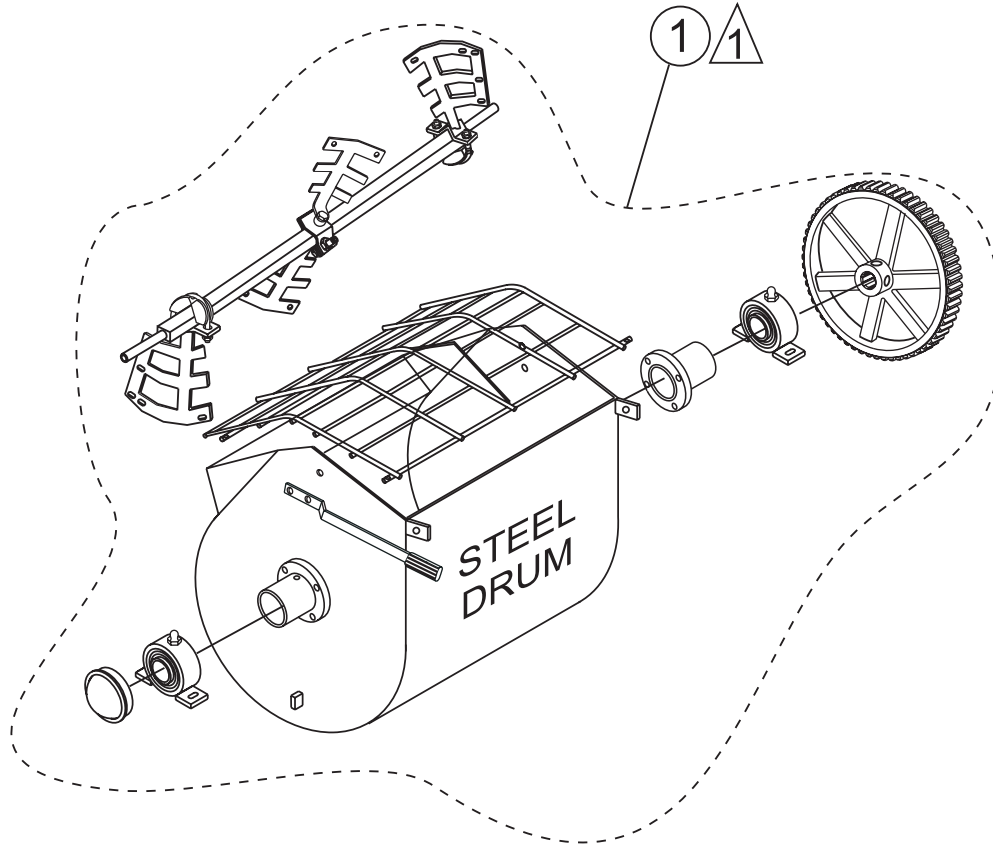

NOTES:

-  COMPLETE DRUM AND PADDLE SHAFT ASSEMBLIES ARE INCLUDED WITHIN DASHED LINES.

WM-90 S/P MIXER — DRUM & PADDLE SHAFT COMPLETE ASSY.

DRUM AND PADDLE SHAFT COMPLETE ASSY. (STEEL DRUM)

<u>NO.</u>	<u>PART NO.</u>	<u>PART NAME</u>	<u>QTY.</u>	<u>REMARKS</u>
1	516063	DRUM AND SHAFT COMPLETE ASSY.	1	INCLUDES ITEMS LISTED BELOW:
	530028	DRUM BEARING BRACKET	2	
	3249	CAP, DUST	1	
	20561-001	BEARING SEALED	2	
	491008	CAP, GREASE FITTING	2	
	EM916019	FITTING, GREASE	2	
	EM969013	NUT, LOCK 3/8"	12	
	3019092	WASHER, FLAT 3/8"	4	
	514754	TRUNNION HUB	2	
	513453	ROLL PIN 3/16" X 3/4"	2	
	20654-001	SEAL, SHAFT (BLACK)	2	
	530029	RING, RETENTION	2	
	20104-002	SEAL, SHAFT URETHANE (YELLOW)	2	
	504943	BOLT 3/8" NC X 2" G5	8	
	514786	DRUM, STEEL	1	
	492484	SET SCREW	2	
	530043	MAIN GEAR	1	
	500432	KEY, 3/8" X 50 MM	1	
	EM963057	CAPSCREW HHCS 3/8 X 1-1/2"	4	
	514752	SHAFT, PADDLE	1	
	492600	WASHER, FLAT 1/2"	2	
	514946	GRATE	1	
	505070	PIN COTTER	2	
	492556	HEX NUT 1/2" G5	2	
	6109180	WASHER, LOCK 1/2"	2	
	EM963692	BOLT 1/2" UNC 1-1/2"	2	
	EM201537	HANDLE DUMP	1	
	15081	GRIP, DUMP HANDLE	1	
	514752	PADDLE SHAFT	1	
	492584	NUT, LOCK 1/2"	6	
	EM200295	PADDLE ARM, CENTER ENGINE END	1	
	510721	BOLT, 1/2 " X 6" G5	2	
	EM200292	INSERT, PADDLE ARM	4	
	EM200296	PADDLE ARM, ENGINE END	1	
	504322	WASHER, FLAT 1/2"	6	
	EM200297	U-BOLT, END PADDLES	2	
	EM200294	PADDLE ARM, CENTER TOW END	1	
	492367	SCREW, HHC 5/16-18 X 1-3/4 G5	14	
	EM923023	WASHER, FLAT 5/16"	28	
	EM200212	BLADE, SIDE, RUBBER	4	
	EM203432	BLADE, SIDE, SCRAPPER	4	
	2105164	NUT, HEX 5/16" NC G5	14	
	EM923343	WASHER, LOCK 5/15"	14	
	EM200293	PADDLE ARM, TOW END	1	
	EM203433	BLADE ,SCRAPPER END	4	
	EM200213	BLADE, RUBBER END	4	

AXLE ASSY.

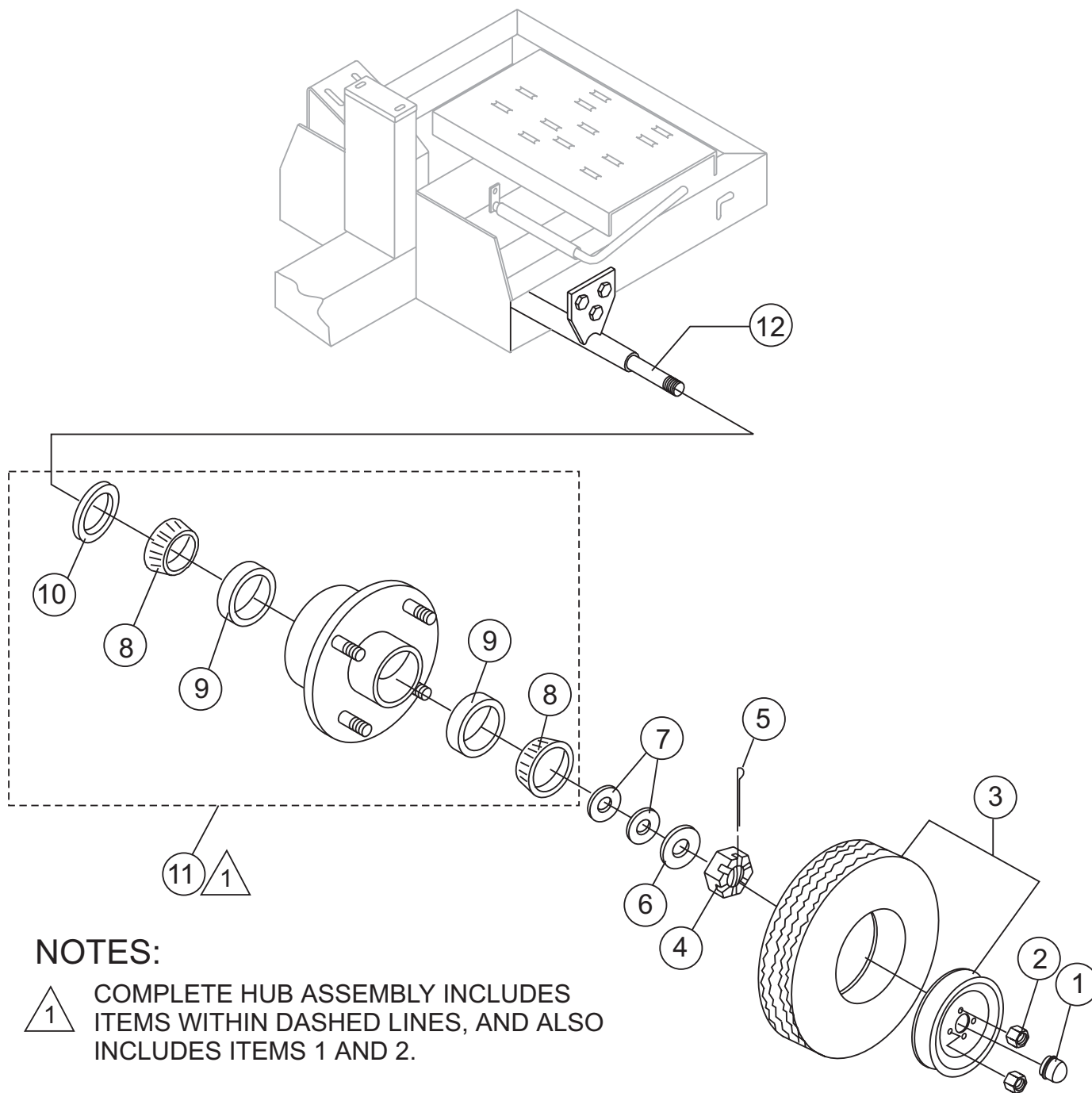

NOTES:

- △ 1 COMPLETE HUB ASSEMBLY INCLUDES ITEMS WITHIN DASHED LINES, AND ALSO INCLUDES ITEMS 1 AND 2.

WM-90S/P MIXER — AXLE ASSY.

AXLE ASSY.

<u>NO</u>	<u>PART NO</u>	<u>PART NAME</u>	<u>QTY.</u>	<u>REMARK</u>
1#	3469	DUST CAP	2	
2#	8115	LUG NUTS	8	
3	3005	TIRE AND RIM, CARLISE	2	
4	8164	ARMLE NUT 1"	2	
5	491688	COTTER PIN 1/8" X 1-1/2'	2	
6	EM511159	WASHER, FLAT, .087" THICKNESS	2	
7	EM501299	WASHER, FLAT, .135" THICKNESS	1	
8#	EM903113	BEARING CONE, (1-1/16" SPINDLE)	4	
9#	EM903012	BEARING CUP	4	
10#	EM914288	OIL SEAL	2	
11	EM941306	HUB ASSY., 4-BOLT (1-1/16" SPINDLE)	2	INCLUDES ITEMS W/#
12	514802	AXLE, UNIVERSAL	1	

WM-90S/P MIXER — ENGINE ASSY.

ENGINE ASSY.

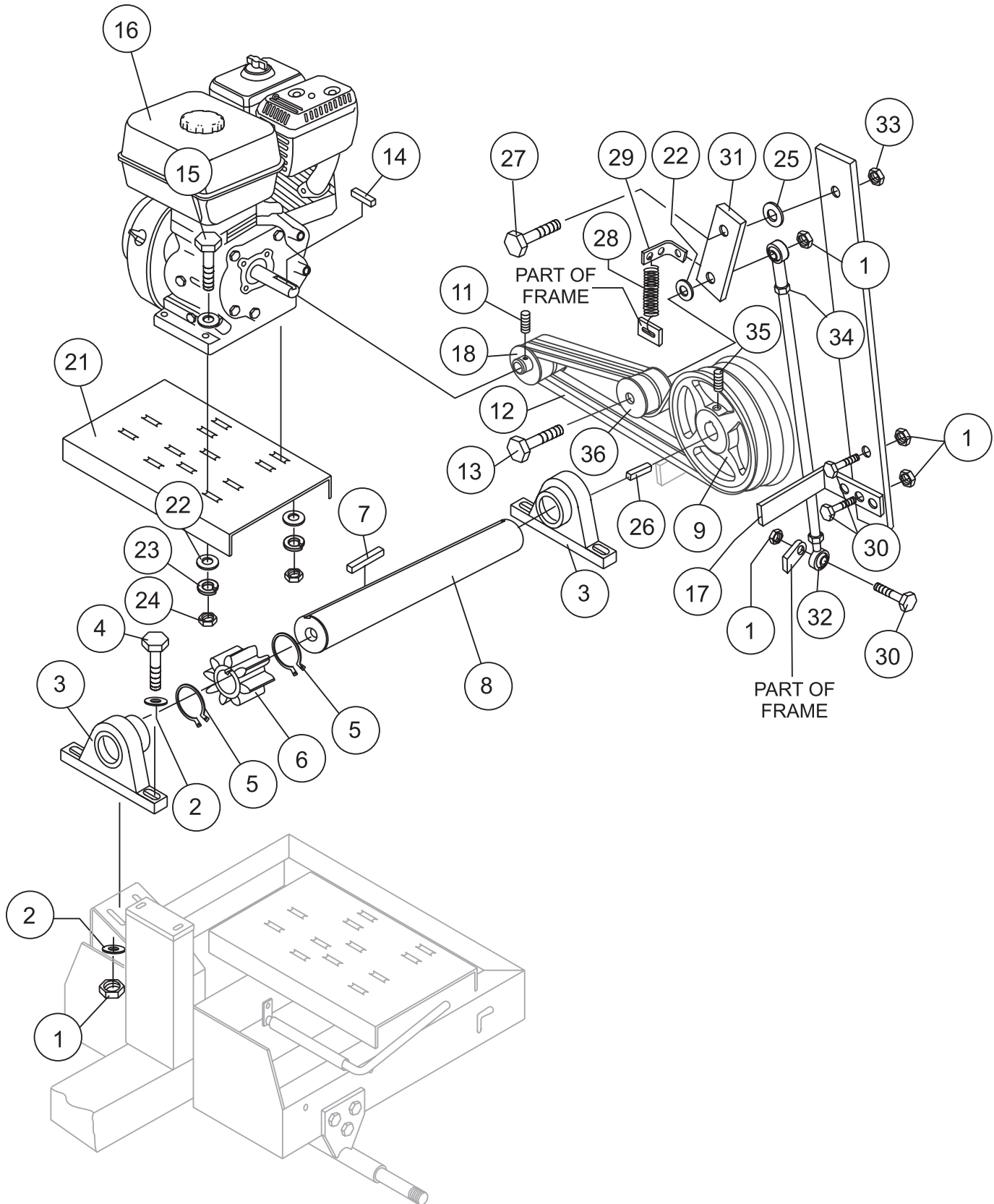

WM-90S/P MIXER — ENGINE ASSY.

ENGINE ASSY.

<u>NO</u>	<u>PART NO</u>	<u>PART NAME</u>	<u>QTY.</u>	<u>REMARKS</u>
1	492583	NUT 3/8" NC G5	8	
2	506488	FLAT WASHER 3/8	8	
3	EM905016	PILLOW BLOCK BEARING	2	
4	492378	BOLT 3/8" NC X 1-3/4" G5	4	
5	490957	RING, RETENTION	2	
6	513868	PINION GEAR	1	
7	500214	KEY, 1/4" X 30 MM	1	
8	EM502226	PINION SHAFT	1	REPLACES P/N 502226
9	492057	PULLEY (LARGE)	1	
10	505084	KEY, 1/4" X 55 MM	1	
11	492467	SET SCREW, 5/16" NC 3/8"	4	
12	505834	V-BELT, A-36	2	
13	503117	BOLT, 3/8" NC X 3" G5	1	
14	90745ZE2600	SQ. KEY 6.3 X 6.3 X 43 MM	1	
15	492378	BOLT 3/8" NC X 1-3/4" G5	4	
16	GX240K1HA2	ENGINE, HONDA	1	
17	515040	BELT RETAINER BAR	1	
18	EM901074	PULLEY, (SMALL)	1	
22	492598	WASHER, FLAT 3/8"	5	
23	492624	WASHER, LOCK 3/8"	4	
24	492554	NUT, HEX 3/8"	4	
25	492600	WASHER, FLAT 1/2"	1	
26	505084	SQ. KEY, 1/4" X 55 MM	1	
27	492394	BOLT 1/2" NC X 1-1/2" G5	1	
28	EM102014	SPRING, EXTENSION	1	
29	EM203098	SPRING CLIP	1	
30	492313	BOLT 3/8" NC X 1-1/2" G5	3	
31	EM507491	ARM, IDLER	1	
32	959080	ROD-END	2	
33	492584	NUT, HEX 1/2"	1	
34	492574	NUT, HEX 3/8" NF G5	2	
35	492476	SET SCREW, 5/16" NC 3/4"	1	
36	EM901515	PULLEY, IDLER	1	
37	515045	ROD	1	

WM-90S/P MIXER — ELECTRIC MOTOR ASSY.

ELECTRIC MOTOR ASSY.

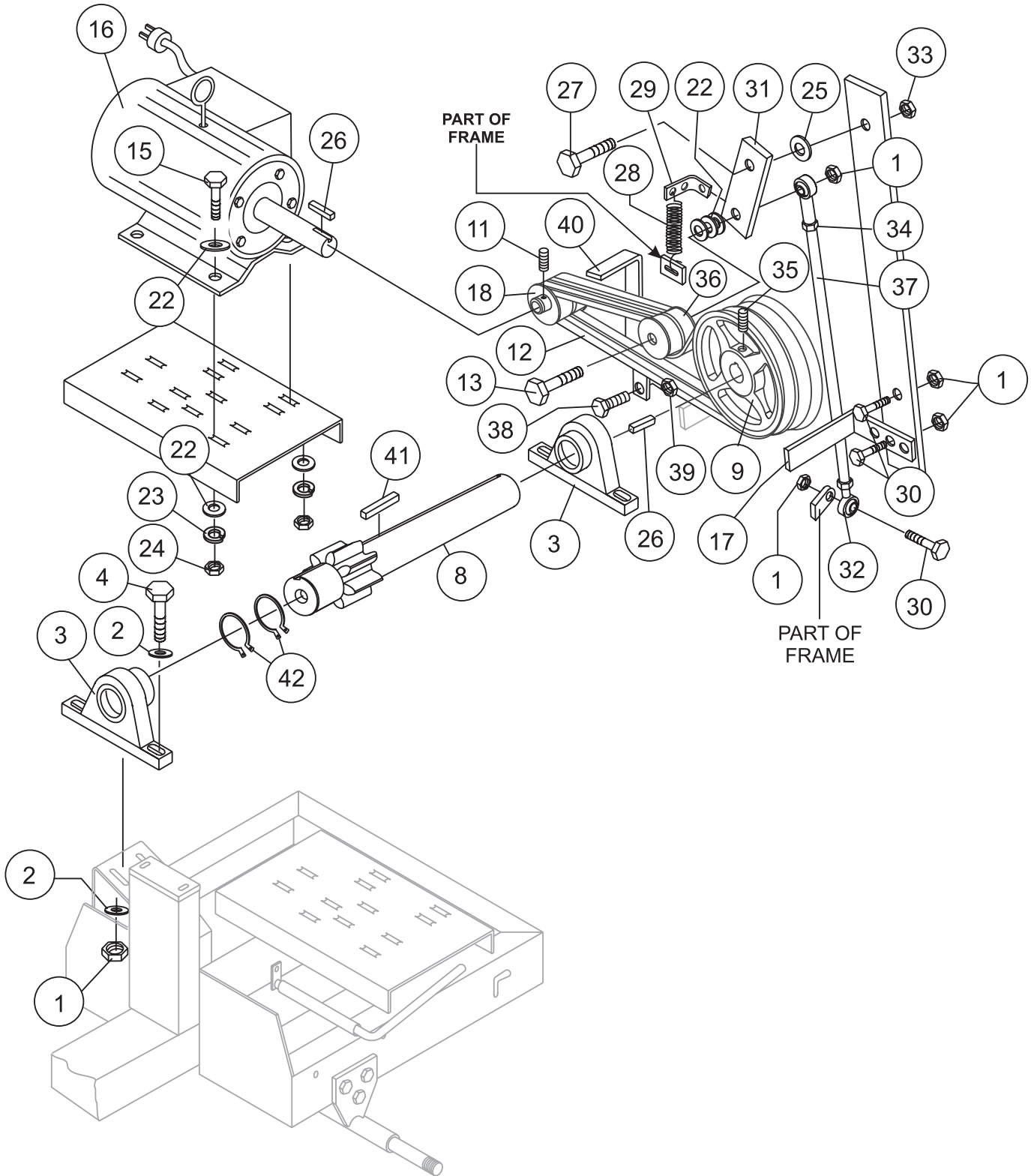

WM-90S/P MIXER — ELECTRIC MOTOR ASSY.

ELECTRIC MOTOR ASSY.

<u>NO</u>	<u>PART NO</u>	<u>PART NAME</u>	<u>QTY.</u>	<u>REMARKS</u>
1	492583	NUT 3/8" NC G5	8	
2	506488	FLAT WASHER 3/8	8	
3	EM905016	PILLOW BLOCK BEARING	2	
4	492378	BOLT 3/8" NC X 1-3/4" G5	4	
5	490957	RING, RETENTION	2	
6	513868	PINION GEAR	1	
7	500214	KEY, 1/4" X 30 MM	1	
8	20216-001	PINION SHAFT	1	
9	505204	PULLEY (LARGE)	1	
10	505084	KEY, 1/4" X 55 MM	1	
11	492467	SET SCREW, 5/16" NC 3/8"	4	
12	507725	V-BELT, A-48	2	
13	503117	BOLT, 3/8" NC X 3" G5	1	
15	492378	BOLT 3/8" NC X 1-3/4" G5	4	
16	EM939315	ELECTRIC MOTOR 3.0 HP	1	
17	515040	BELT RETAINER BAR	1	
18	EM901513	PULLEY, (SMALL)	1	
22	492598	WASHER, FLAT 3/8"	5	
23	492624	WASHER, LOCK 3/8"	4	
24	492554	NUT, HEX 3/8"	4	
25	492600	WASHER, FLAT 1/2"	1	
26	505084	KEY, 1/4" X 55 MM	1	
27	492394	BOLT 1/2" NC X 1-1/2" G5	1	
28	EM102014	SPRING, EXTENSION	1	
29	EM203098	SPRING CLIP	1	
30	492313	BOLT 3/8" NC X 1-1/2" G5	3	
31	EM507491	ARM, IDLER	1	
32	959080	ROD-END	2	
33	492584	NUT, HEX 1/2"	1	
34	492574	NUT, HEX 3/8" NF G5	2	
35	492476	SET SCREW, 5/16" NC 3/4"	1	
36	EM901515	PULLEY, IDLER	1	
37	515045	ROD	1	
38	492364	BOLT, 5/16" NC X 1" G5	1	
39	492554	NUT, HEX 3/8"	4	
40	EM507715	BELT RETAINER BAR	1	
41	500214	KEY, 1/4" X 30 MM	1	
42	490957	RING, RETENTION	2	

WM-90S/P MIXER — CABINET ASSY.

CABINET ASSY.

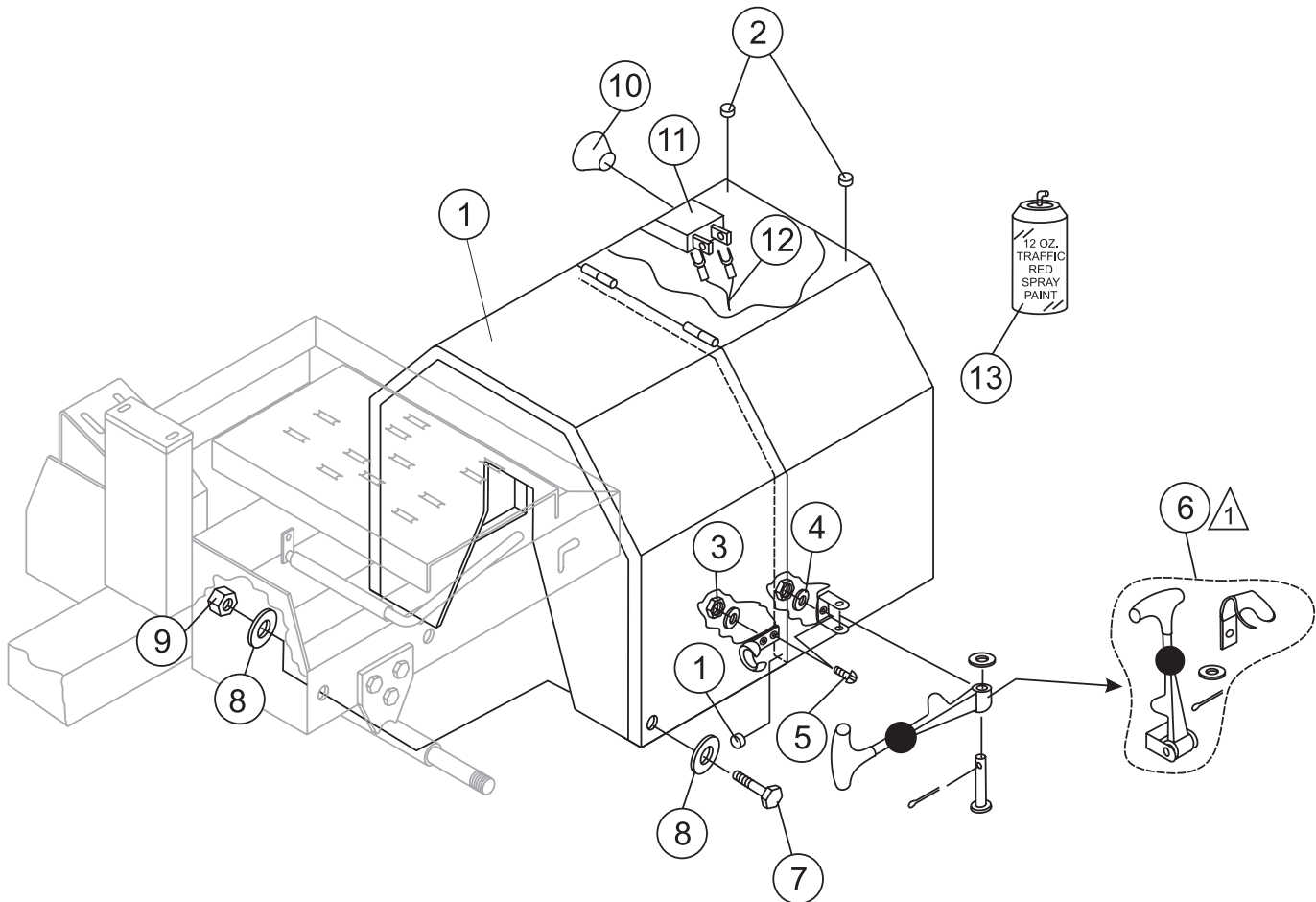

NOTES:



COMPLETE LATCH ASSEMBLY
INCLUDES ITEMS WITHIN DASHED
LINES. ITEMS CANNOT BE PURCHASED
SEPARATELY.

WM-90S/P MIXER — CABINET ASSY.

CABINET ASSY.

<u>NO</u>	<u>PART NO</u>	<u>PART NAME</u>	<u>QTY.</u>	<u>REMARKS</u>
1	514964	CABINET, ENGINE W/DECALS	1	INCLUDES ITEMS W/*
2	490202	RUBBER PROTECTOR	4	
3	13287	LOCK NUT 8-32	6	REPLACEMENT PART ONLY
4	2203	WASHER, FLAT #10	6	REPLACEMENT PART ONLY
5	1307	SCREW RHMS 8-32 X 1/2"	6	REPLACEMENT PART ONLY
6*	491010	LATCH ASSY., COMPLETE	2	
7	492375	BOLT 3/8" NC X 1" G5	4	
8	492598	WASHER, FLAT 3/8"	4	
9	492583	NUT 3/8" NC G5	4	
10	29174-001	KNOB, MUSHROOM	1	
11	29173-001	SWITCH, PUSH-PULL	1	
12	504135C	WIRE HARNESS	1	
13	EM974007	PAINT, SPRAY 12 OZ. TRAFFIC RED	1	

HONDA GX240K1HA2 ENGINE — AIR CLEANER ASSY.

AIR CLEANER ASSY.

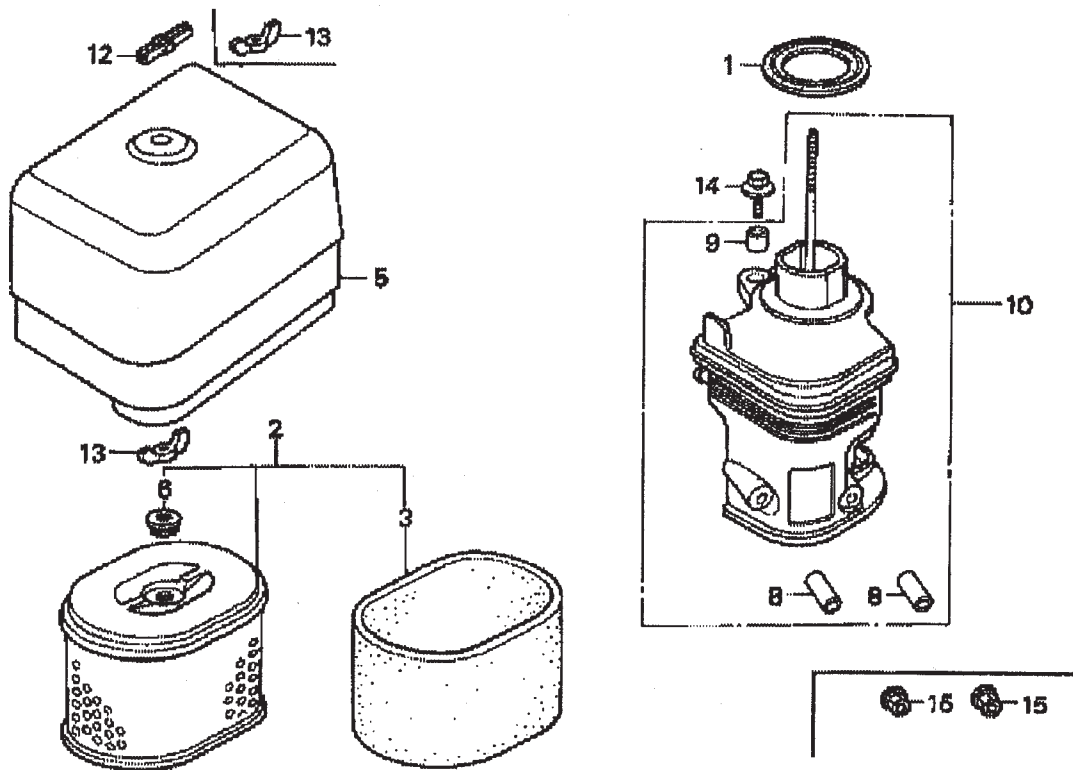

HONDA GX240K1HA2 ENGINE — AIR CLEANER ASSY.

AIR CLEANER ASSY.

<u>NO.</u>	<u>PART NO.</u>	<u>PART NAME</u>	<u>QTY.</u>	<u>REMARKS</u>
1	16271ZE2000	GASKET, ELBOW	1	INCLUDES ITEM W/*
2	17210ZE2515	ELEMENT, AIR CLEANER, DUAL	1	
3 *	17218ZE2505	FILTER, OUTER	1	
5	17231ZH9820	COVER, AIR CLEANER	1	
6	17232891000	GROMMET, AIR CLEANER	1	
8 #	17238ZE2310	COLLAR, AIR CLEANER	2	
9 #	17239ZE1000	COLLAR B, AIR CLEANER	1	
10	17410ZE2020	ELBOW COMP., AIR CLEANER	1	INCLUDES ITEM W/#
12	0037806000	WINGNUT 6MM	1	
13	90325044000	WINGNUT, TOOL BOX SETTING	2	
14	90009ZE2003	BOLT- WASHER 6 X 22	1	
15	9405006000	NUT, FLANGE 6MM	2	

HONDA GX240K1HA2 ENGINE — CAMSHAFT ASSY.

CAMSHAFT ASSY.

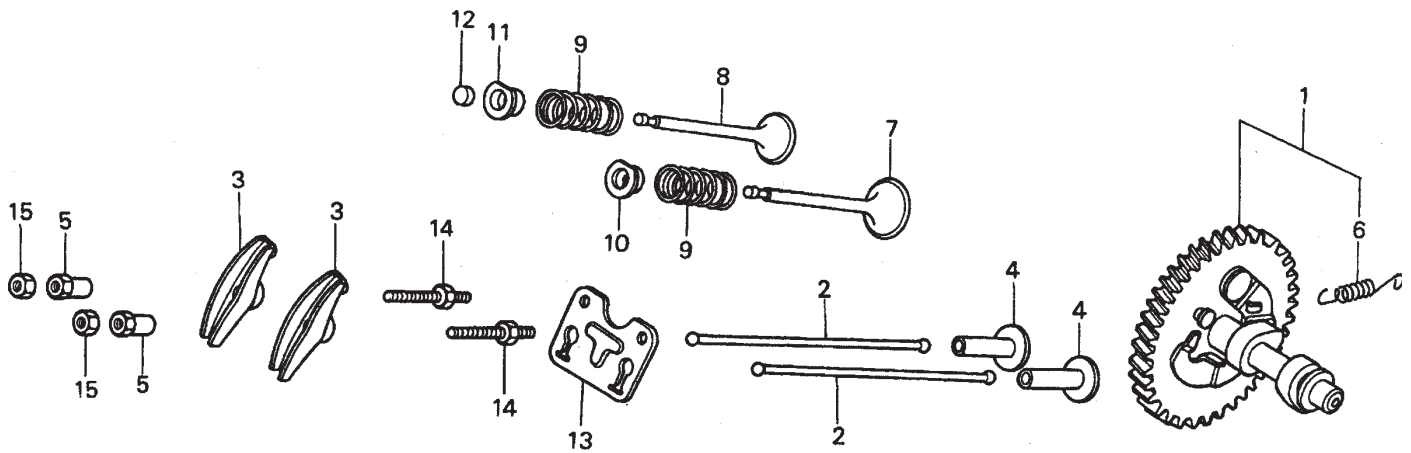

HONDA GX240K1HA2 ENGINE — CAMSHAFT ASSY.

CAMSHAFT ASSY.

<u>NO.</u>	<u>PART NO.</u>	<u>PART NAME</u>	<u>QTY.</u>	<u>REMARKS</u>
1	14100ZE2W01	CAMSHAFT ASSY.	1	INCLUDES ITEM W/*
1	14100ZE2306	CAMSHAFT	1	
2	14410ZE2013	ROD PUSH	2	
3	14431ZE2010	ARM VALVE ROCKER	2	
4	14441ZE2000	LIFTER VALVE	2	
5	14451ZE1013	PIVOT ROCKER ARM	2	
6*	14568ZE1000	SPRING, WEIGHT RETURN	1	
7	14711ZE2000	VALVE, IN.	1	
8	14721ZE2000	VALVE, EX.	1	
9	14751ZE2003	SPRING, VALVE	2	
10	14771ZE2000	RETAINER, IN. VALVE SPRING	1	
11	14773ZE2000	RETAINER, EX. VALVE SPRING	1	
12	14781ZE2000	ROTATOR, VALVE	1	
13	14791ZE2010	PLATE, PUSH ROD GUIDE	1	
14	90012ZE0010	BOLT, PIVOT 8MM	2	
15	90206ZE1000	NUT, PIVOT ADJ.	2	

HONDA GX240K1HA2 ENGINE — CARBURETOR ASSY.

CARBURETOR ASSY.

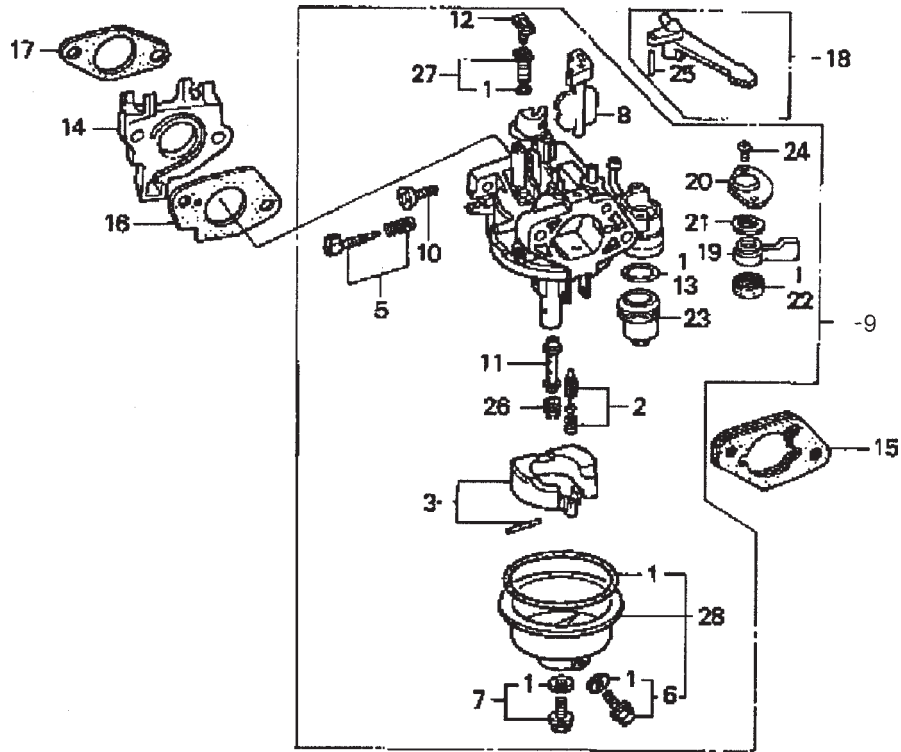

HONDA GX240K1HA2 ENGINE — CARBURETOR ASSY.

CARBURETOR ASSY.

<u>NO.</u>	<u>PART NO.</u>	<u>PART NAME</u>	<u>QTY.</u>	<u>REMARKS</u>
1*+	16010ZE2812	GASKET SET	1	
2*	16011ZA0931	VALVE SET, FLOAT	1	
3*	16013ZA0931	FLOAT SET	1	
5*	16016ZHW01	SCREW SET	1	
6*+	16024ZE1811	SCREW SET, DRAIN	1	
7*+	16028ZE0005	SCREW SET B	1	
8*	16028ZE2005	CHOKE SET	1	
9*	16100ZE2W71	CARBURETOR ASSY.....	1 INCLUDES ITEMS W/*
10*	16124ZE0005	SCREW, THROTTLE STOP	1	
11*	16166ZE2W70	NOZZLE, MAIN	1	
12*	16075GHBB00	COLLAR, SET	1	
13*	16075GHBB00	O-RING	1	
14	16211ZE2000	INSULATOR, CARB.	1	
15	16220ZA0702	SPACER COMP., CARB.	1	
16	16221ZA0800	GASKET, CARBURETOR	1	
17	16223ZA0800	GASKET, INSULATOR	1	
18	16610ZE1000	LEVER COMP., CHOKE, STD.	1	
19*	16953ZE1812	LEVER, VALVE	1	
20*	16954ZE1811	PLATE, LEVER SETTING	1	
21*	16956ZE1811	SPRING, VALVE LEVER	1	
22*	16957ZE1812	GASKET, VALVE	1	
23*	16967ZE0811	CUP, FUEL STRAINER	1	
24*	93500030060H	SCREW, PAN 3 X 6	2	
25	9430520122	PIN, SPRING 2 X 12	1	
26*	99101ZH70820	JET, MAIN #82, OPTIONAL	1	
26*	99101ZH70850	JET, MAIN #85, OPTIONAL	1	
26*	99101ZH80880	JET, MAIN #88	1	
27*	99204ZE20400	JET SET, PILOT #40	1	
28*	16015ZE8005	CHAMBER SET, FLOAT	1 INCLUDES ITEMS W/+

HONDA GX240K1HA2 ENGINE — CONTROL ASSY.

CONTROL ASSY.

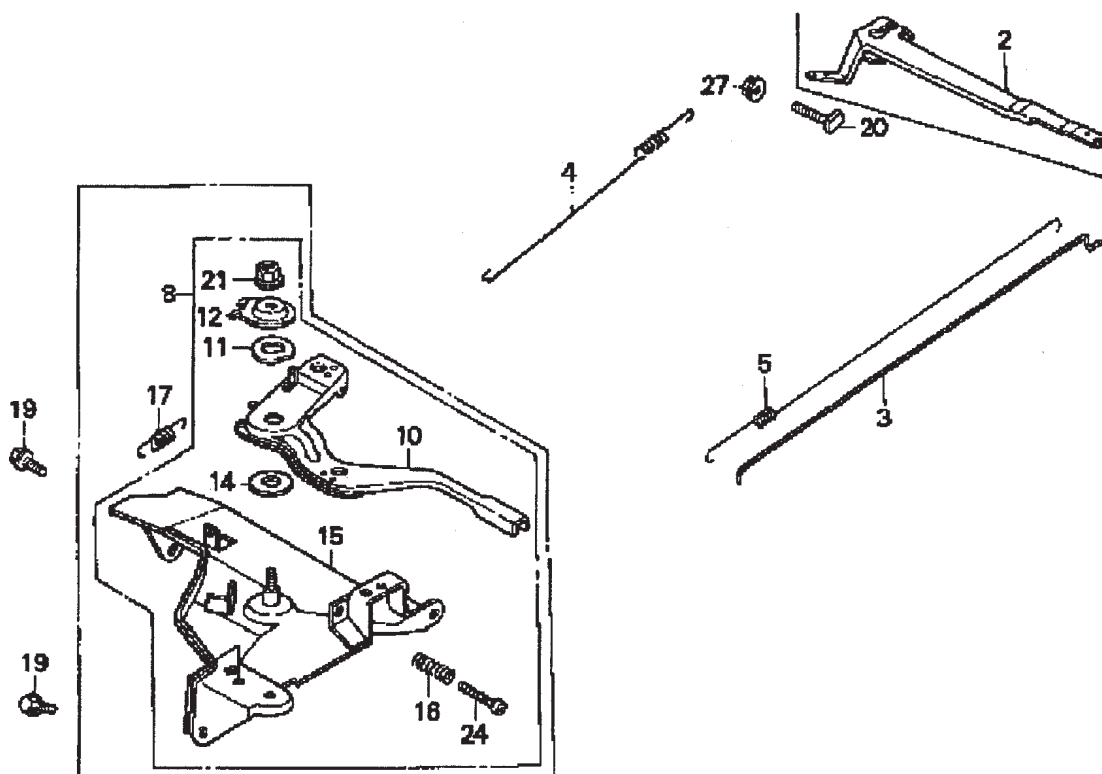

HONDA GX240K1HA2 ENGINE — CONTROL ASSY.

CONTROL ASSY.

<u>NO.</u>	<u>PART NO.</u>	<u>PART NAME</u>	<u>QTY.</u>	<u>REMARKS</u>
2	16551ZE2000	ARM, GOVERNOR	1	
3	16555ZE2000	ROD, GOVERNOR	1	
4	16561ZE2000	SPRING, GOVERNOR	1	
5	16571ZE2000	SPRING, THROTTLE RETURN	1	
8	16570ZE2W00	CONTROL ASSEMBLY	1	INCLUDES ITEMS W/*
10*	16571ZE2W00	LEVER, CONTROL	1	
11*	16574ZE1000	SPRING, LEVER	1	
12*	16575ZE2W00	WASHER, CONTROL LEVER	1	
14*	16578ZE1000	SPACER, CONTROL LEVER	1	
15*	16581ZE2W00	BASE, CONTROL	1	
16*	16584883300	SPRING, CONTROL ADJUSTING	1	
19	90013883000	BOLT, FLANGE (6 X 12) (CT200)	2	
20	90015ZE5010	BOLT, GOVERNOR ARM	1	
21*	90114SA0000	NUT, SELF- LOCK (6MM)	1	
24*	93500050280A	SCREW, PAN (5 X 28)	1	
27	9405006000	NUT, FLANGE	1	

HONDA GX240K1HA2 ENGINE — CRANKCASE COVER ASSY.

CRANKCASE COVER ASSY.

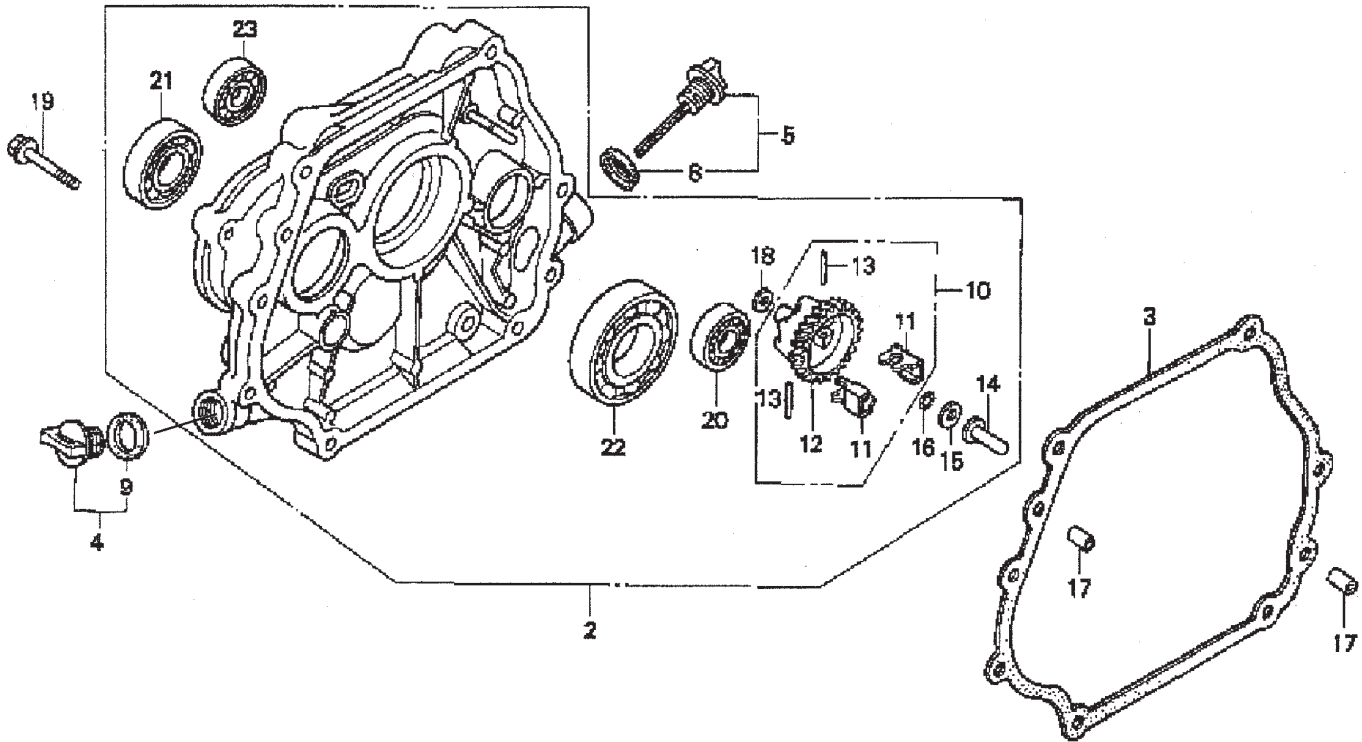

HONDA GX240K1HA2 ENGINE — CRANKCASE COVER ASSY.

CRANKCASE COVER ASSY.

<u>NO.</u>	<u>PART NO.</u>	<u>PART NAME</u>	<u>QTY.</u>	<u>REMARKS</u>
2	11400ZE2621	COVER ASSY., CRANKCASE (H-TYPE) (BALANCER)	1	INCLUDES ITEMS W/*
3	11381ZE2801	GASKET, CASE COVER	1	
4	15600ZG4003	CAP ASSY., OIL FILLER	1	INCLUDES ITEMS W/#
5	15600735003	CAP ASSY., OIL FILLER	1	INCLUDES ITEMS W/%
8%	15625ZE1003	GASKET, OIL FILLER CAP	1	
9#	15625ZE1003	GASKET, OIL FILLER CAP	1	
10	16510ZE2811	GOVERNOR ASSEMBLY (BALANCER)	1	INCLUDES ITEMS W/+
11* +	16511ZE2000	WEIGHT, GOVERNOR	2	
12* +	16512ZE2811	HOLDER, GOVERNOR WEIGHT	1	
13* +	16513ZE2000	PIN, GOVERNOR WEIGHT	2	
14*	16531ZE2000	SLIDER, GOVERNOR	1	
15*	90473147000	WASHER (6 X 16)	1	
16*	90602ZE1000	CLIP, GOVERNOR HOLDER	1	
17	90701HC4000	PIN, DOWEL (8 X 12)	2	
18*	58176	WASHER, PLAIN (6MM)	1	
19	957010803500	BOLT, FLANGE (8 X 35)	7	
20*	961006202000	BEARING, RADIAL BALL (6202)	1	
21*	961006204000	BEARING, RADIAL BALL (6204)	1	
22*	961006206000	BEARING, RADIAL BALL (6206)	1	
23*	961006302000	BEARING, RADIAL BALL (6302)	1	

HONDA GX240K1HA2 ENGINE — CRANKSHAFT ASSY.

CRANKSHAFT ASSY.

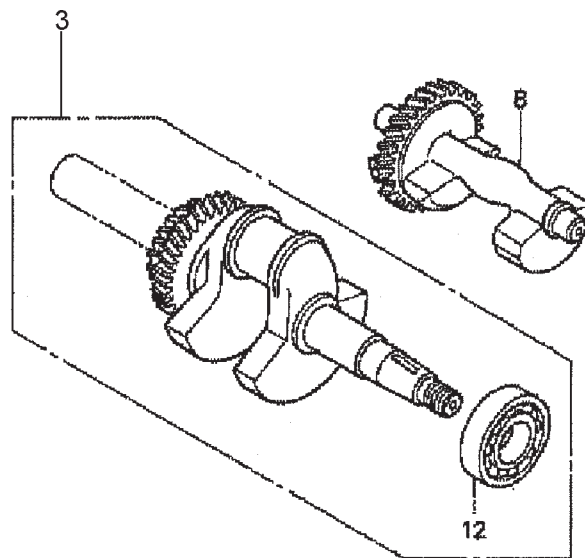
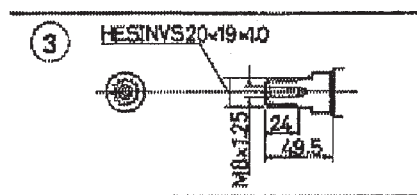

HONDA GX240K1HA2 ENGINE — CRANKSHAFT ASSY.

CRANKSHAFT ASSY.

<u>NO.</u>	<u>PART NO.</u>	<u>PART NAME</u>	<u>QTY.</u>	<u>REMARKS</u>
3	13320ZE2611	CRANKSHAFT (L- TYPE).....	1	INCLUDES ITEM W/*
8	13351ZE2010	WEIGHT BALANCER	1	
12*	961006206000	BEARING, RADIAL BALL (6206)	1	

HONDA GX240K1HA2 ENGINE — CYLINDER BARREL ASSY.

CYLINDER BARREL ASSY.

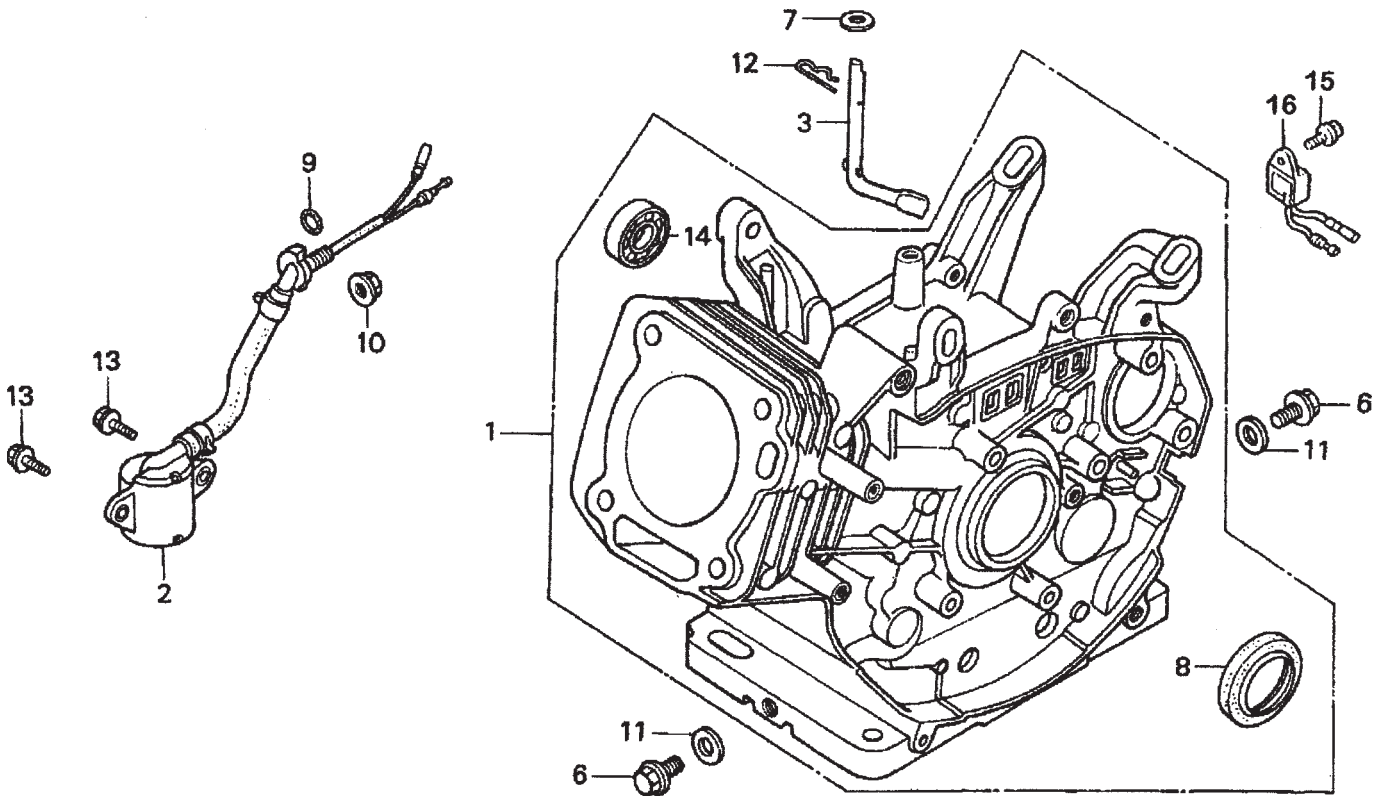

HONDA GX240K1HA2 ENGINE — CYLINDER BARREL ASSY.

CYLINDER BARREL ASSY.

<u>NO.</u>	<u>PART NO.</u>	<u>PART NAME</u>	<u>QTY.</u>	<u>REMARKS</u>
1	12000ZE2834	CYLINDER ASSY., BALANCER + OIL ALERT	1	INCLUDES ITEMS W/*
2	15510ZE2043	SWITCH ASSY., OIL LEVEL	1	
3	16541ZE2010	SHAFT, GOVERNOR ARM	1	
6	90131896650	BOLT, DRAIN PLUG	2	
7	90446KE1000	WASHER 8.2 X17X0.8	1	
8*	91201890003	OIL SEAL 30X46X8	1	
9	91353671003	O-RING 14MM ARAI	1	
10	9405010000	NUT FLANGE 10MM	1	
11	031112230	WASHER, DRAIN PLUG 12MM	2	
12	9425110000	PIN, LOCK 10MM	1	
13	957010601200	BOLT, FLANGE 6X12	2	
14*	961006202000	BEARING, RADIAL BALL 6202	1	
15	90013883000	BOLT, FLANGE 6X12 CT200	1	
16	34150ZH7003	ALERT UNIT, OIL	1	

HONDA GX240K1HA2 ENGINE — CYLINDER HEAD ASSY.

CYLINDER HEAD ASSY.

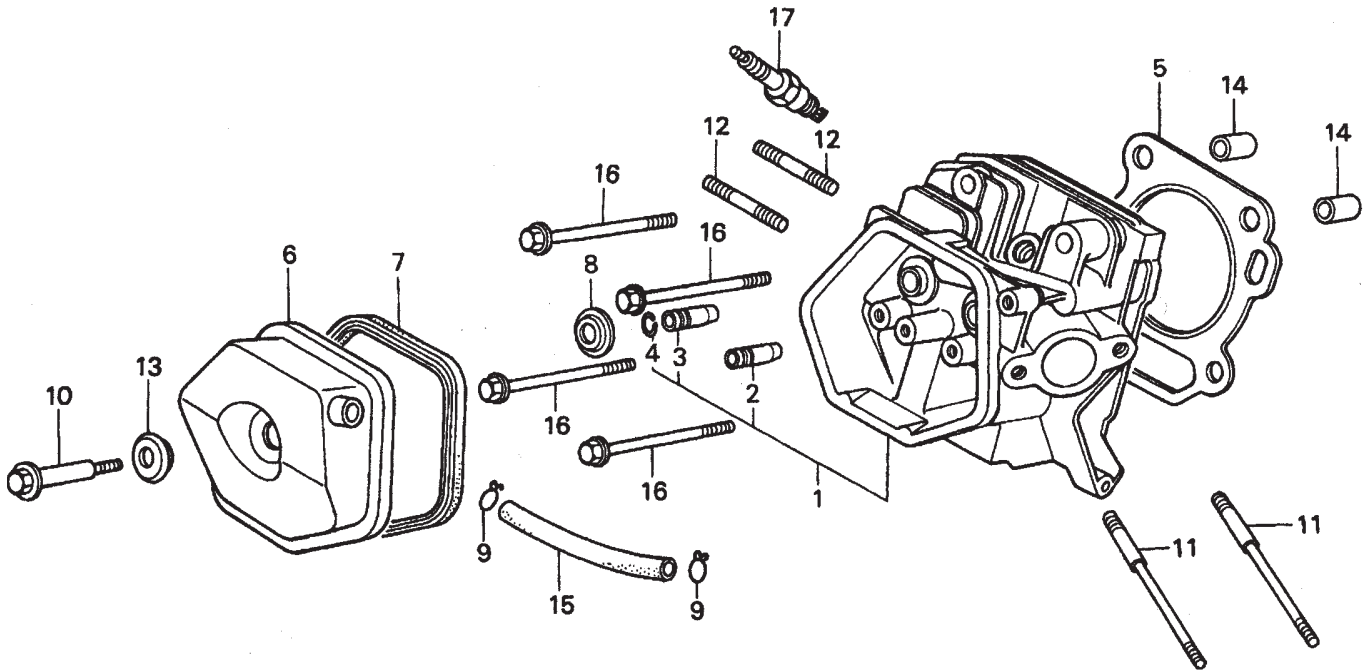

HONDA GX240K1HA2 ENGINE — CYLINDER HEAD ASSY.

CYLINDER HEAD ASSY.

<u>NO.</u>	<u>PART NO.</u>	<u>PART NAME</u>	<u>QTY.</u>	<u>REMARKS</u>
1	12200ZH9000	CYLINDER HEAD COMP.	1	INCLUDES ITEMS W/*
2*	12204ZE2306	GUIDE, VALVE, OS, OPTIONAL	1	
3*	12205ZE2305	GUIDE, EX. VALVE, OS, OPTIONAL	1	
4*	12216ZE2300	CLIP, VALVE GUIDE	1	
5	12251ZE2800	GASKET, CYLINDER HEAD	1	
6	12310ZE2020	COVER COMP., HEAD	1	
7	12391ZE2020	GASKET, CYLINDER HEAD COVER	1	
8	14775ZE2010	SEAT, VALVE SPRING	1	
10	90014ZE2000	BOLT, HEAD COVER	1	
11	90042ZE2000	BOLT, STUD 8X123	2	
12	92900080320E	BOLT, STUD 8X47	2	
13	90441ZE2010	WASHER COMP., HEAD COVER	1	
14	9430112200	PIN A, DOWEL 12X20	2	
15	950051100130M	BULK HOSE, VACUUM 11X1000, 11X100	1	
16	957011008000	BOLT, FLANGE 10X80	4	
17	9807956846	SPARK PLUG, BPR6ES, NGK	1	
17	9807956855	SPARK PLUG, W20EPR-U, DENSO	1	

HONDA GX240K1HA2 ENGINE — FAN COVER ASSY.

FAN COVER ASSY.

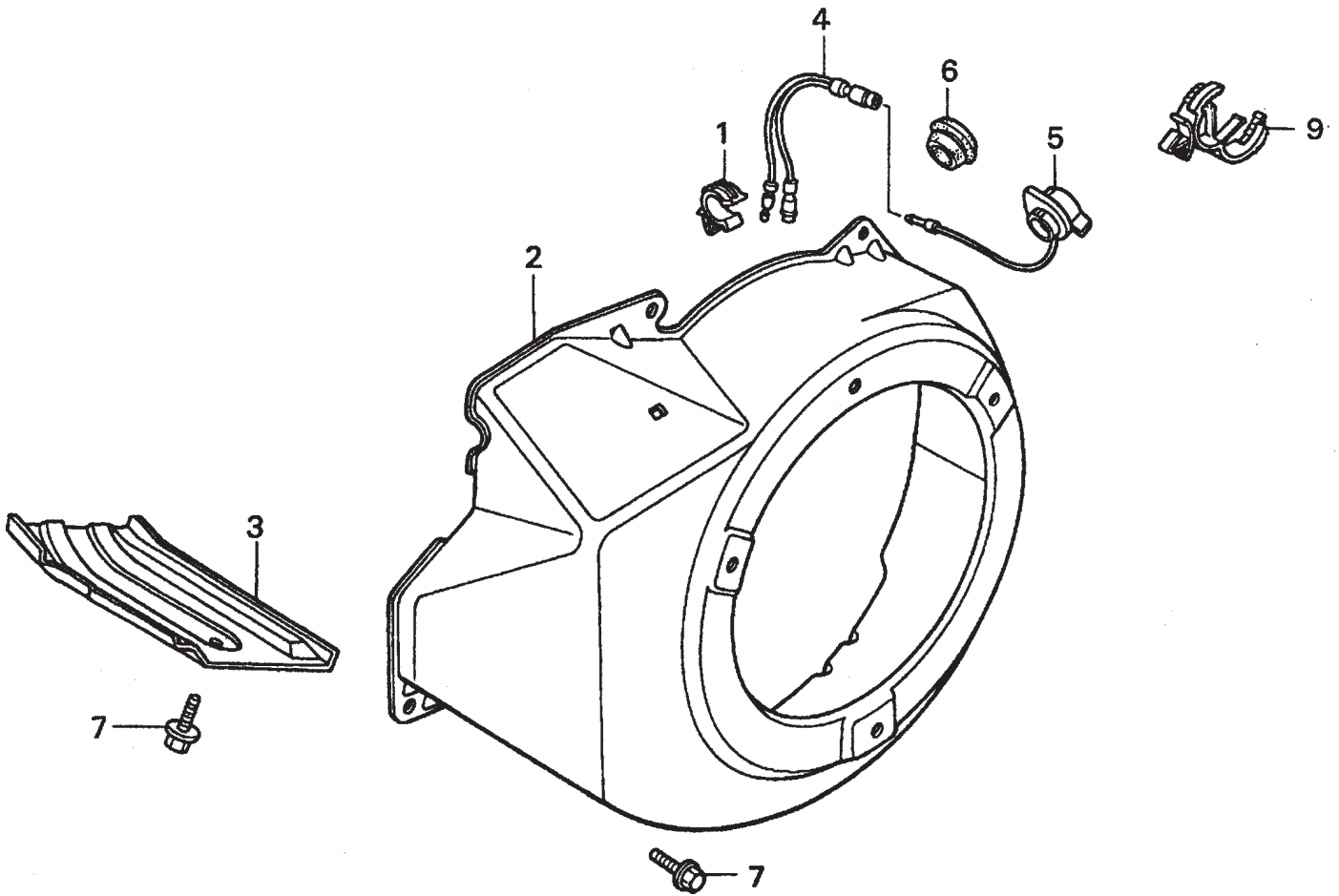

HONDA GX240K1HA2 ENGINE — FAN COVER ASSY.

FAN COVER ASSY.

<u>NO.</u>	<u>PART NO.</u>	<u>PART NAME</u>	<u>QTY.</u>	<u>REMARKS</u>
1	16731ZE2003	CLIP, TUBE	1	
2	19610ZE2010ZC	COVER COMP., FAN *NH1* BLACK	1	
3	19631ZE2D00	SHROUD	1	
4	32197ZH8003	SUB-HARNESS	1	
5	36100ZE1015	SWITCH ASSY., ENGINE STOP	1	
7	90013883000	BOLT, FLANGE 6X12, CT200	6	
9	90684ZA0601	CLIP, WIRE HARNESS	1	

HONDA GX240K1HA2 ENGINE — FLYWHEEL ASSY.

FLYWHEEL ASSY.

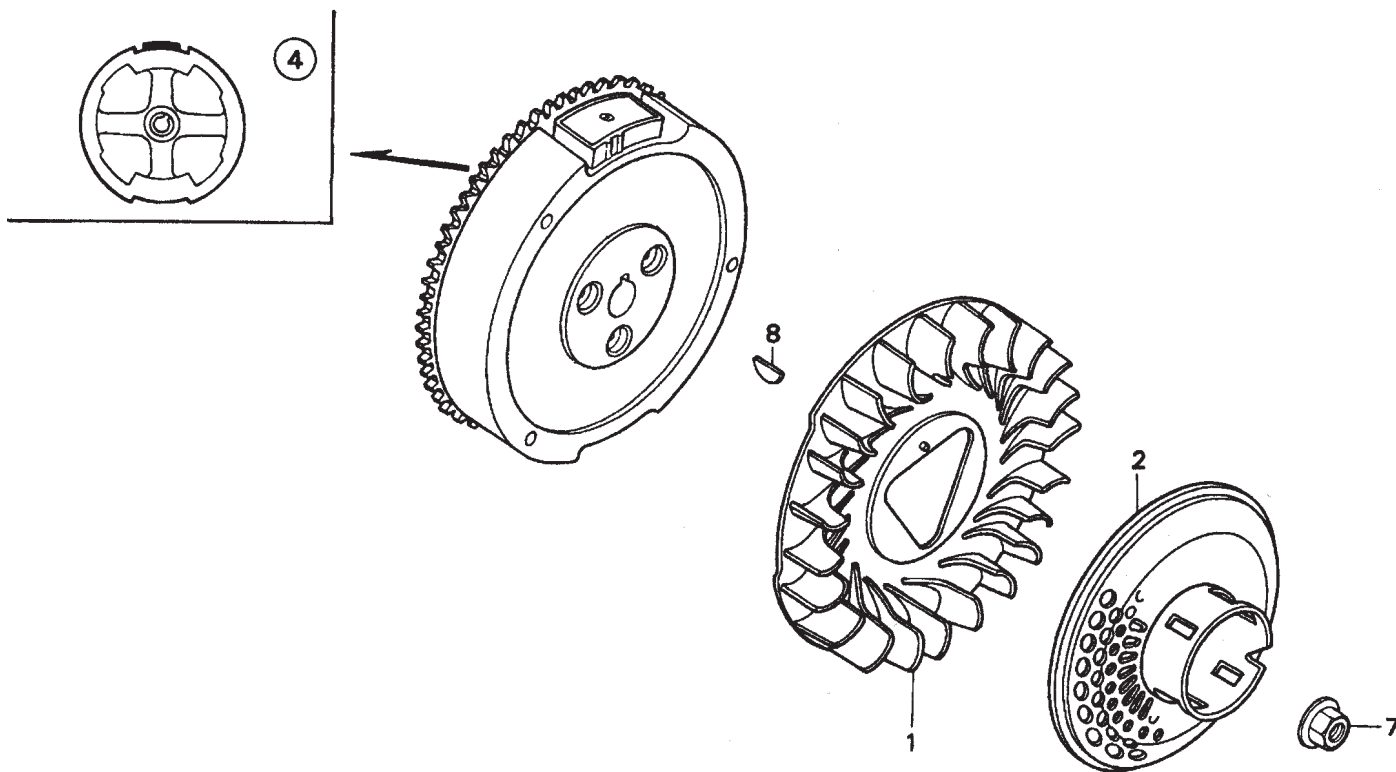

HONDA GX240K1HA2 ENGINE — FLYWHEEL ASSY.

FLYWHEEL ASSY.

<u>NO.</u>	<u>PART NO.</u>	<u>PART NAME</u>	<u>QTY.</u>	<u>REMARKS</u>
1	19511ZE2000	FAN, COOLING	1	
2	28450ZE2W11	PULLEY COMP., STARTER, SCREEN GRID	1	
4	31100ZE2010	FLYWHEEL COMP.	1	
7	90201ZE3V00	NUT, SPECIAL 16MM	1	
8	90741ZE2000	KEY, SPECIAL WOODRUFF 25X18	1	

HONDA GX240K1HA2 ENGINE — MUFFLER ASSY.

MUFFLER ASSY.

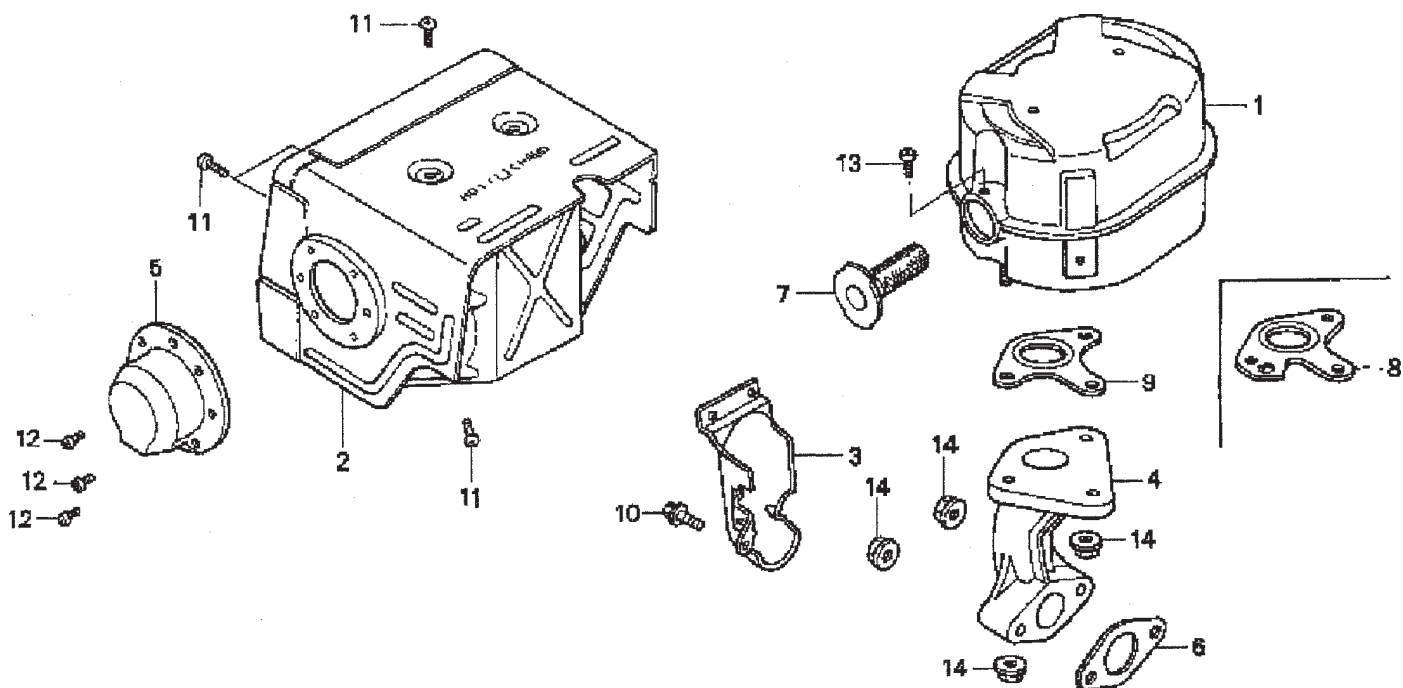

HONDA GX240K1HA2 ENGINE — MUFFLER ASSY.

MUFFLER ASSY.

<u>NO.</u>	<u>PART NO.</u>	<u>PART NAME</u>	<u>QTY.</u>	<u>REMARKS</u>
1	18310ZE2W00	MUFFLER	1	
2	18320ZE2W01	PROTECTOR, MUFFLER	1	
3	18323ZE2W00	PROTECTOR, EX. PIPE	1	
4	18330ZE2W00	PIPE, EX.	1	
5	18331ZE2810	CAP, MUFFLER	1	
6	18333ZK6Y00	GASKET, EX. PIPE	1	
7	18355ZE2010	ARRESTER, SPARK	1	
8	18381ZE2W10	GASKET, MUFFLER (ARRESTER)	1	
9	18381ZE2800	GASKET, MUFFLER	1	
10	90013883000	BOLT, FLANGE (6 X 12) (CT200)	1	
11	90050ZE1000	SCREW, TAPPING (5 X 8)	6	
12	90055ZE1000	SCREW, TAPPING (4 X 6)	3	
13	90050ZE1000	SCREW, TAPPING (5 X 8) (OPTIONAL)	1	
14	9405008000	NUT, FLANGE (8MM)	5	

HONDA GX240K1HA2 ENGINE — FUEL TANK ASSY.

FUEL TANK ASSY.

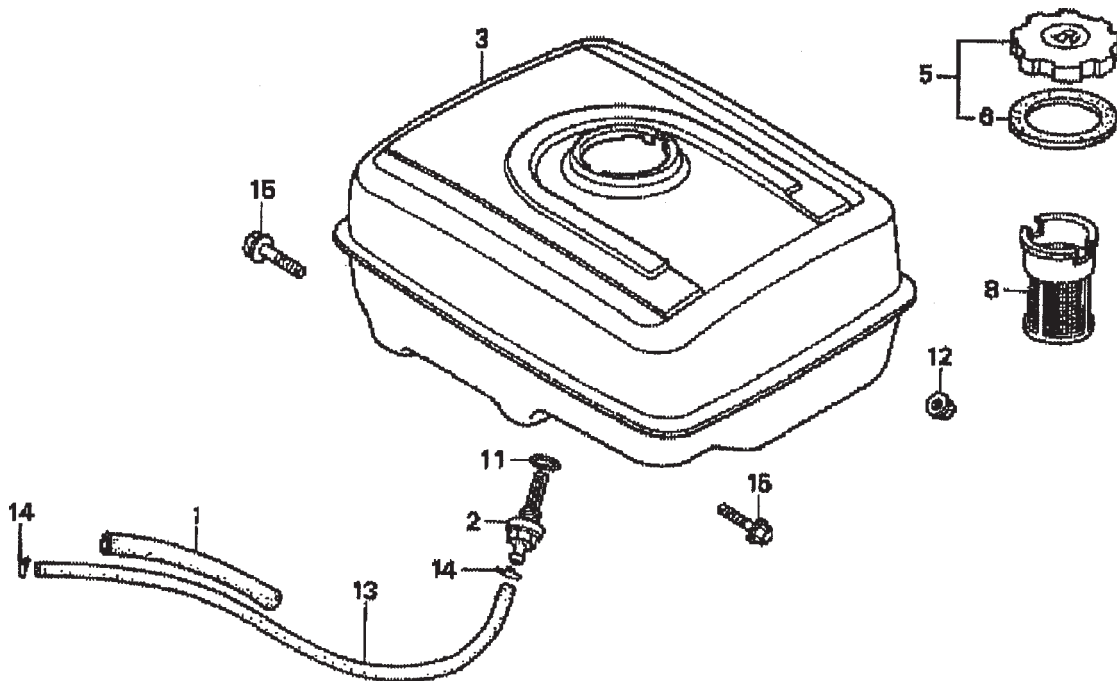

HONDA GX240K1HA2 ENGINE — FUEL TANK ASSY.

FUEL TANK ASSY.

<u>NO.</u>	<u>PART NO.</u>	<u>PART NAME</u>	<u>QTY.</u>	<u>REMARKS</u>
1	16854ZH8000	RUBBER SUPPORTER 107MM	1	
2	16955ZE1000	JOINT, FUEL TANK	1	
3	17510ZE2010ZD	TANK COMP., FUEL *NH1*, BLACK	1	
5	17620ZH7023	CAP COMP., FUEL FILLER	1	INCLUDES ITEMS W/*
6*	17631ZH7003	GASKET, FUEL FILLER CAP	1	
8	17672ZE2W01	FILTER, FUEL	1	
11	91353671003	O-RING 14MM, ARAI	1	
12	9405008000	NUT, FLANGE 8MM	2	
13	950014500360M	BULK HOSE, FUEL 4.5X3000, 4.5X222	1	
14	9500202080	CLIP, TUBE, B8	2	
15	957010802500	BOLT, FLANGE 8X25	2	

HONDA GX240K1HA2ENGINE — IGNITION ASSY.

IGNITION COIL ASSY.

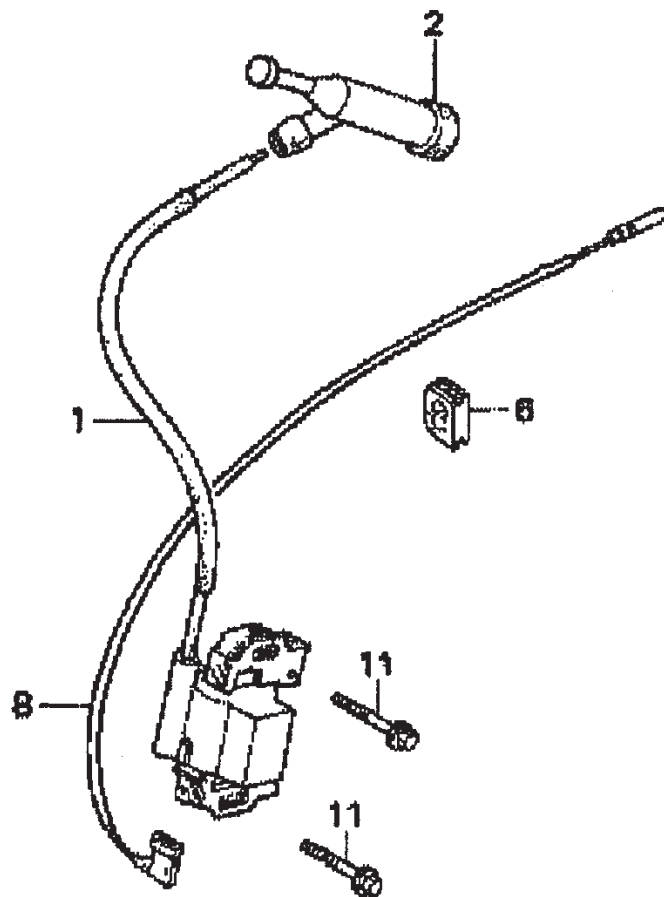

HONDA GX240K1HA2ENGINE — IGNITION ASSY.

IGNITION COIL ASSY.

<u>NO.</u>	<u>PART NO.</u>	<u>PART NAME</u>	<u>QTY.</u>	<u>REMARKS</u>
1	30500ZF6W02	COIL ASSY., IGNITION	1	
2	30700ZE1013	CAP ASSY., NOISE SUPPRESSOR	1	
6	31512ZE2000	GROMMET, WIRE	1	
8	36101ZE1010	WIRE, STOP SWITCH 370MM	1	
11	90015883000	BOLT, FLANGE 6X28	2	

HONDA GX240K1HA2 ENGINE — PISTON ASSY.

PISTON ASSY.

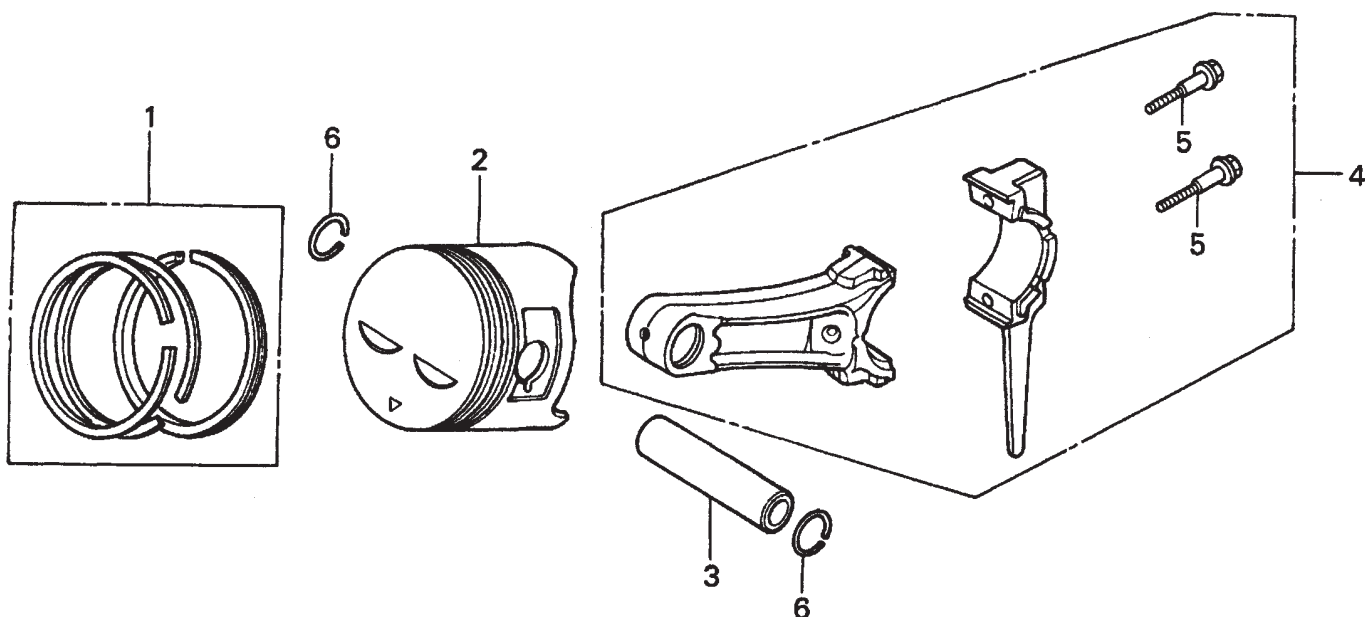

HONDA GX240K1HA2 ENGINE — PISTON ASSY.

PISTON ASSY.

<u>NO.</u>	<u>PART NO.</u>	<u>PART NAME</u>	<u>QTY.</u>	<u>REMARKS</u>
1	13010ZE2013	RING SET, PISTON, STD.	1	
1	13011ZE2013	RING SET, PISTON, OS 0.25, OPTIONAL	1	
1	13012ZE2013	RING SET, PISTON, OS 0.50, OPTIONAL	1	
1	13013ZE2013	RING SET, PISTON, 0.75, OPTIONAL	1	
2	13101ZE2W00	PISTON, STANDARD	1	
2	13102ZE2W00	PISTON, OS 0.25, OPTIONAL	1	
2	13103ZE2W00	PISTON, OS 0.50, OPTIONAL	1	
2	13104ZE2W00	PISTON, 0.75, OPTIONAL	1	
3	13111ZE2000	PIN, PISTON	1	
4	13200ZE2000	ROD ASSY., CONNECTING STANDARD	1	INCLUDES ITEMS W/*
4	13200ZE2305	ROD ASSY., CONNECTING, US 0.25, OPT.	1	
5*	90001ZE8000	BOLT, CONNECTING ROD	2	
6	90551ZE1000	CLIP, PISTON PIN 18MM	2	

HONDA GX240K1HA2 ENGINE — RECOIL STARTER ASSY.

RECOIL STARTER ASSY.

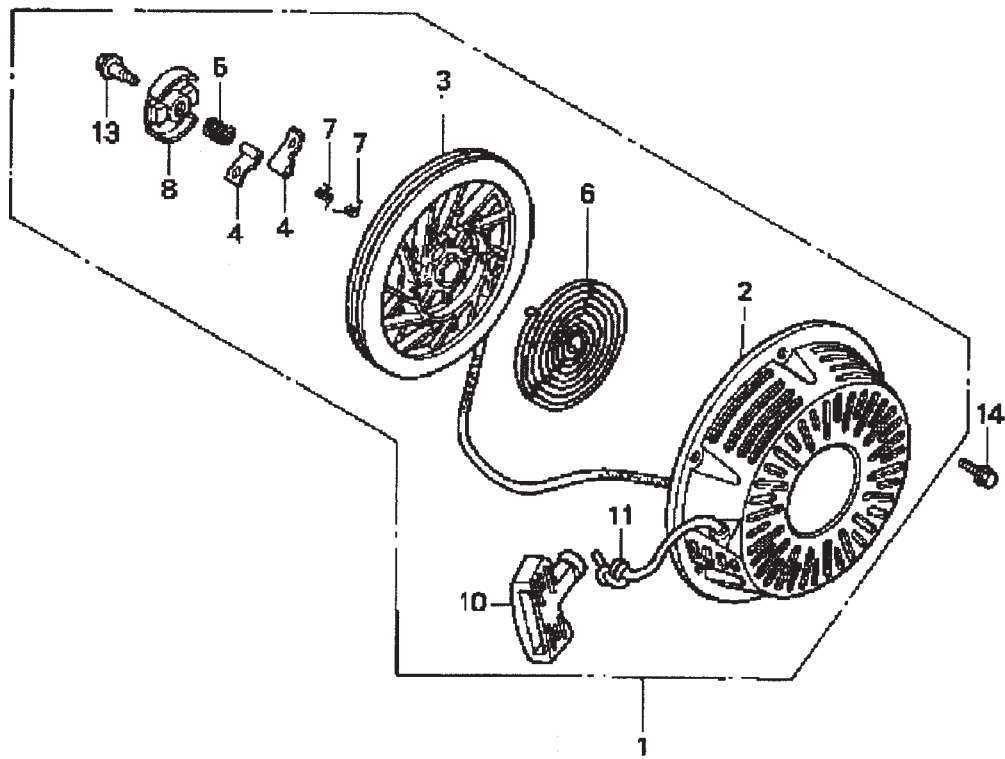

HONDA GX240K1HA2 ENGINE — RECOIL STARTER ASSY.

RECOIL STARTER ASSY.

<u>NO.</u>	<u>PART NO.</u>	<u>PART NAME</u>	<u>QTY.</u>	<u>REMARKS</u>
1	28400ZE2W01ZB	STARTER ASSY., RECOIL *NH1*, BLK	1	INCLUDES ITEMS W/*
2*	28410ZE2W01ZB	CASE COMP., RECOIL STARTER *NH1*, BLK	1	
3*	28421ZE2W01	PULLEY, RECOIL STARTER	1	
4*	28422ZE2W01	RATCHET, STARTER	2	
5*	28441ZE2W01	SPRING, FRICTION	1	
6*	28442ZE2W01	SPRING, STARTER RETURN	1	
7*	28443ZE2W01	SPRING RATCHET	2	
8*	28444ZE2W01	RETAINER, SPRING	1	
10*	28461ZE2W02	GRIP, STARTER	1	
11*	28462ZE2W11	ROPE, RECOIL STARTER	1	
13*	90004ZE2W01	SCREW, CENTER	1	
14	90008ZE2003	BOLT, FLANGE 6X10	3	

HONDA GX240K1HA2 ENGINE — GEAR REDUCTION ASSY.

GEAR REDUCTION ASSY.

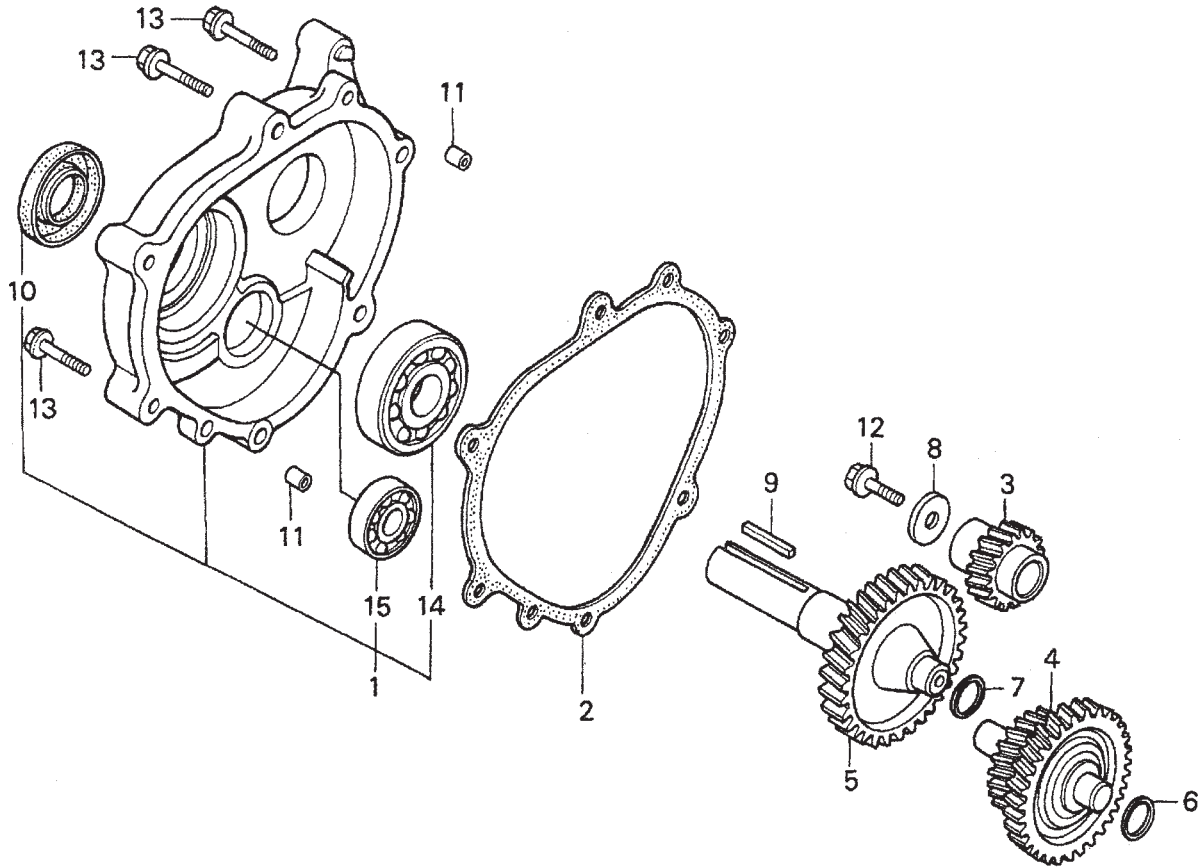

HONDA GX240K1HA2 ENGINE — GEAR REDUCTION ASSY.

GEAR REDUCTION ASSY.

<u>NO.</u>	<u>PART NO.</u>	<u>PART NAME</u>	<u>QTY.</u>	<u>REMARKS</u>
1	11500ZE2620	COVER ASSY, REDUCTION CASE	1	INCLUDES ITEMS W/*
2	11521ZE2800	GASKET, CHAIN CASE COVER	1	
3	22103ZE2620	GEAR, PRIMARY DRIVE (17T)	1	
4	23220ZE2621	COUNTERSHAFT	1	
5	23710ZE2621	SHAFT, P.T.O. (H- TYPE)	1	
6	90401ZE2620	SHIM A (OPTIONAL)	AR	
7	90402ZE2620	SHIM B (OPTIONAL)	AR	
8	90473842000	WASHER (8MM)	1	
9	90745ZE2600	KEY (6.3 X 6.3 X 43)	1	
10*	91201890003	OIL SEAL (30 X 46 X 8)	1	
11	9430108140	PIN A, DOWEL (8 X 14)	2	
12	957010802500	BOLT, FLANGE (8 X 25)	1	
13	957010804000	BOLT, FLANGE (8 X 40)	6	
14*	961006206000	BEARING, RADIAL BALL (6206)	1	
15*	961006302000	BEARING, RADIAL BALL (6302)	1	

HONDA GX240K1HA2 ENGINE — LABEL ASSY.

LABEL ASSY.

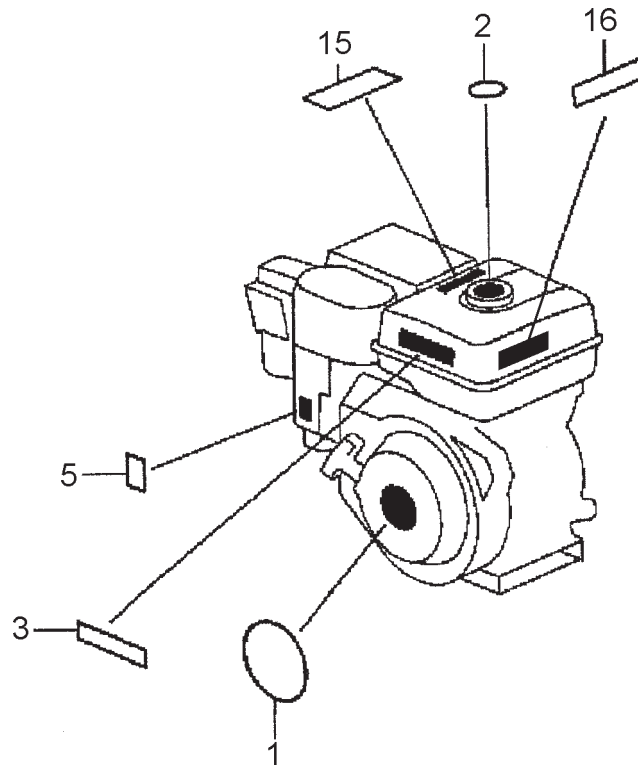

HONDA GX240K1HA2 ENGINE — LABEL ASSY.

LABELS ASSY.

<u>NO.</u>	<u>PART NO.</u>	<u>PART NAME</u>	<u>QTY.</u>	<u>REMARKS</u>
1	87521ZE2W01	EMBLEM, INTERNAL	1	
2	87522ZE1810	MARK, CAUTION, EXTERNAL	1	
3	87522ZH9000	LABEL, CAUTION	1	
5	87528ZE2810	MARK, CHOKE, EXTERNAL	1	
15	87586ZH7W00	LABEL, FUEL CAUTION	1	
16	87532ZH8810	MARK, OIL ALERT	1	

TERMS AND CONDITIONS OF SALE — PARTS

PAYMENT TERMS

Terms of payment for parts are net 30 days.

FREIGHT POLICY

All parts orders will be shipped collect or prepaid with the charges added to the invoice. All shipments are F.O.B. point of origin. Multiquip's responsibility ceases when a signed manifest has been obtained from the carrier, and any claim for shortage or damage must be settled between the consignee and the carrier.

MINIMUM ORDER

The minimum charge for orders from Multiquip is \$15.00 net. Customers will be asked for instructions regarding handling of orders not meeting this requirement.

RETURNED GOODS POLICY

Return shipments will be accepted and credit will be allowed, subject to the following provisions:

1. A Returned Material Authorization must be approved by Multiquip prior to shipment.
2. To obtain a Return Material Authorization, a list must be provided to Multiquip Parts Sales that defines item numbers, quantities, and descriptions of the items to be returned.
 - a. The parts numbers and descriptions must match the current parts price list.
 - b. The list must be typed or computer generated.
 - c. The list must state the reason(s) for the return.
 - d. The list must reference the sales order(s) or invoice(s) under which the items were originally purchased.
 - e. The list must include the name and phone number of the person requesting the RMA.
3. A copy of the Return Material Authorization must accompany the return shipment.
4. Freight is at the sender's expense. All parts must be returned freight prepaid to Multiquip's designated receiving point.

5. Parts must be in new and resalable condition, in the original Multiquip package (if any), and with Multiquip part numbers clearly marked.
6. The following items are not returnable:
 - a. Obsolete parts. (If an item is in the price book and shows as being replaced by another item, it is obsolete.)
 - b. Any parts with a limited shelf life (such as gaskets, seals, "O" rings, and other rubber parts) that were purchased more than six months prior to the return date.
 - c. Any line item with an extended dealer net price of less than \$5.00.
 - d. Special order items.
 - e. Electrical components.
 - f. Paint, chemicals, and lubricants.
 - g. Decals and paper products.
 - h. Items purchased in kits.
7. The sender will be notified of any material received that is not acceptable.
8. Such material will be held for five working days from notification, pending instructions. If a reply is not received within five days, the material will be returned to the sender at his expense.
9. Credit on returned parts will be issued at dealer net price at time of the original purchase, less a 15% restocking charge.
10. In cases where an item is accepted, for which the original purchase document can not be determined, the price will be based on the list price that was effective twelve months prior to the RMA date.
11. Credit issued will be applied to future purchases only.

PRICING AND REBATES

Prices are subject to change without prior notice. Price changes are effective on a specific date and all orders received on or after that date will be billed at the revised price. Rebates for price declines and added charges for price increases will not be made for stock on hand at the time of any price change.

Multiquip reserves the right to quote and sell direct to Government agencies, and to Original Equipment Manufacturer accounts who use our products as integral parts of their own products.

SPECIAL EXPEDITING SERVICE

A \$35.00 surcharge will be added to the invoice for special handling including bus shipments, insured parcel post or in cases where Multiquip must personally deliver the parts to the carrier.

LIMITATIONS OF SELLER'S LIABILITY

Multiquip shall not be liable hereunder for damages in excess of the purchase price of the item with respect to which damages are claimed, and in no event shall Multiquip be liable for loss of profit or good will or for any other special, consequential or incidental damages.

LIMITATION OF WARRANTIES

No warranties, express or implied, are made in connection with the sale of parts or trade accessories nor as to any engine not manufactured by Multiquip. Such warranties made in connection with the sale of new, complete units are made exclusively by a statement of warranty packaged with such units, and Multiquip neither assumes nor authorizes any person to assume for it any other obligation or liability whatever in connection with the sale of its products. Apart from such written statement of warranty, there are no warranties, express, implied or statutory, which extend beyond the description of the products on the face hereof.

Effective: February 22, 2006

PARTS MANUAL

HERE'S HOW TO GET HELP

PLEASE HAVE THE MODEL AND SERIAL
NUMBER *ON-HAND* WHEN CALLING

UNITED STATES

Multiquip Corporate Office

18910 Wilmington Ave. Tel. (800) 421-1244
Carson, CA 90746 Fax (800) 537-3927
Contact: mq@multiquip.com

Mayco Parts

800-306-2926 Fax: 800-672-7877
310-537-3700 Fax: 310-637-3284

Service Department

800-421-1244 Fax: 310-537-4259
310-537-3700

MQ Parts Department

800-427-1244 Fax: 800-672-7877
310-537-3700 Fax: 310-637-3284

Warranty Department

800-421-1244, Ext. 279 Fax: 310-537-1173
310-537-3700, Ext. 279

Technical Assistance

800-478-1244 Fax: 310-631-5032

MEXICO

MQ Cipsa

Carr. Fed. Mexico-Puebla KM 126.5 Tel: (52) 222-225-9900
Momoxpan, Cholula, Puebla 72760 Mexico Fax: (52) 222-285-0420
Contact: pmastretta@cipsa.com.mx

CANADA

Multiquip

4110 Industriel Boul. Tel: (450) 625-2244
Laval, Quebec, Canada H7L 6V3 Fax: (450) 625-8664
Contact: jmartin@multiquip.com

UNITED KINGDOM

Multiquip (UK) Limited Head Office

Hanover Mill, Fitzroy Street, Tel: 0161 339 2223
Ashton-under-Lyne, Fax: 0161 339 3226
Lancashire OL7 0TL
Contact: sales@multiquip.co.uk

BRAZIL

Multiquip

Av. Evandro Lins e Silva, 840 - grupo 505 Tel: 011-55-21-3433-9055
Barra de Tijuca - Rio de Janeiro Fax: 011-55-21-3433-9055
Contact: cnavarro@multiquip.com.br, srentes@multiquip.com.br

© COPYRIGHT 2008, MULTIQUIP INC.

Multiquip Inc, the MQ logo are registered trademarks of Multiquip Inc. and may not be used, reproduced, or altered without written permission. All other trademarks are the property of their respective owners and used with permission.

This manual MUST accompany the equipment at all times. This manual is considered a permanent part of the equipment and should remain with the unit if resold.

The information and specifications included in this publication were in effect at the time of approval for printing. Illustrations, descriptions, references and technical data contained in this manual are for guidance only and may not be considered as binding. Multiquip Inc. reserves the right to discontinue or change specifications, design or the information published in this publication at any time without notice and without incurring any obligations.

Your Local Dealer is:

