

---

# M3096EX AND M3096GX IMAGE SCANNER OPERATOR'S GUIDE

---

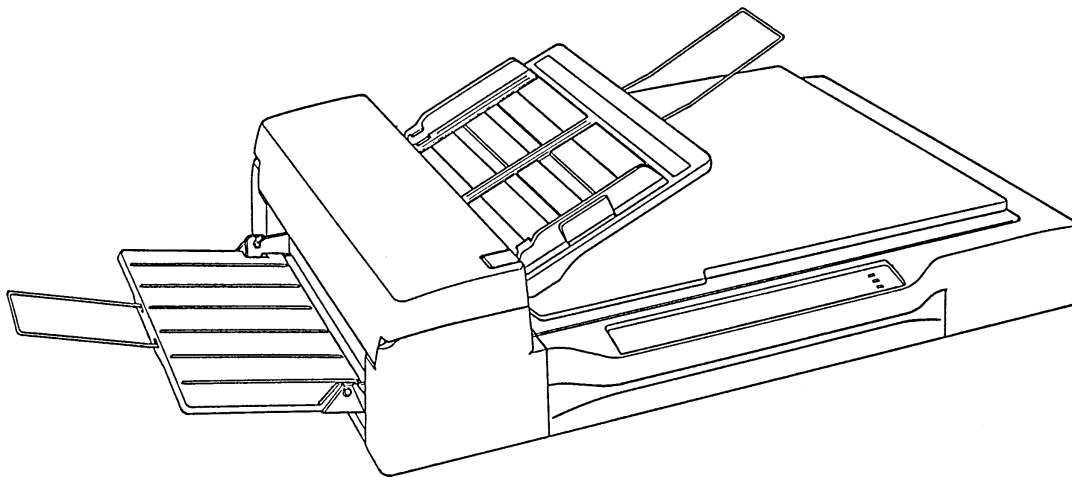

REVISION RECORD		
Edition	Date published	Revised contents
01	June, 1994	First edition
02	August, 1994	Contents revised
03	January, 1995	Contents revised
04	April, 1995	Pick Roller replacement procedure added
05	September, 1995	Pad replacement procedure added
06	January, 1996	Appendix C, Declaration of Conformity added
07	August, 1996	Declaration of Conformity revised
Specification No.: C150-E009-07EN		

This digital apparatus does not exceed the Class A limit for radio noise emissions from digital apparatus set out in the Radio interference Regulations of the Canadian Department of Communications.

Le présent appareil numérique n'émet pas de bruits radioélectriques dépassant les limites applicables aux appareils numériques de la classe A prescrites dans le Règlement sur le brouillage radioélectrique édicté par le ministère des Communications du Canada.

Maschinenlärminformationsverordnung 3. GSGV, 18.01.1991: Der arbeitsplatzbezogene Schalldruckpegel beträgt 70 dB(A) oder weniger gemäß ISO 7779.

This equipment has been tested and found to comply with the limits for a Class A digital device, pursuant to Part 15 of the FCC Rules. These limits are designed to provide reasonable protection against harmful interference when the equipment is operated in a commercial environment. This equipment generates, uses, and can radiate radio frequency energy and, if not installed and used in accordance with the instruction manual, may cause harmful interference to radio communications. Operation of this equipment in a residential area is likely to cause harmful interference in which case the user will be required to correct the interference at his own expense.

The contents of this manual is subject to change without prior notice.

All Rights Reserved,  
Copyright ©1994, 1995, 1996 FUJITSU LIMITED

## **Conventions**

Special information, such as warnings, cautions are indicated as follows:

### **WARNING**

A **WARNING** indicates that personal injury may result if you do not follow a procedure correctly.

### **CAUTION**

A **CAUTION** indicates that damage to the scanner may result if you do not follow a procedure correctly.

### **NOTICE**

A **NOTICE** provides “how-to” tips or suggestions to help you perform a procedure correctly. **NOTES** are particularly useful for first-time users.

# CONTENTS

	page
<b>CHAPTER 1 PREFACE</b> .....	1-1
<b>CHAPTER 2 COMPONENTS</b> .....	2-1
2.1 Checking the Components .....	2-1
2.2 Part Names and Functions .....	2-2
2.2.1 Exterior view of image scanner .....	2-2
2.2.2 Functions of each part .....	2-3
2.3 Indication Panel Functions (standard model) .....	2-4
2.3.1 Indicators .....	2-4
2.4 Operator Panel Functions (LCD model) .....	2-4
2.4.1 Indicators .....	2-5
2.4.2 Buttons and liquid crystal display screen .....	2-5
2.4.3 Liquid crystal display screen .....	2-6
2.4.4 Messages .....	2-11
<b>CHAPTER 3 INSTALLATION AND CONNECTIONS</b> .....	3-1
3.1 Precautions .....	3-1
3.2 Removing the Carrier Fixing Bracket .....	3-2
3.3 Connections .....	3-3
3.4 Mounting the Stacker .....	3-5
3.5 SCSI -ID Setting .....	3-6
<b>CHAPTER 4 OPERATIONS</b> .....	4-1
4.1 Turning on the Power .....	4-1
4.2 Reading a Document in Flatbed Mode .....	4-2
4.2.1 Reading a standard-size document .....	4-2
4.2.2 Reading a page from a thick book .....	4-3
4.2.3 Reading a document larger than the document board .....	4-4
4.3 Reading Documents in ADF Mode .....	4-5

<b>CHAPTER 5 MAINTENANCE</b> .....	5-1
5.1 Removing Jammed Documents .....	5-1
5.2 Notes on Daily Use .....	5-2
5.3 Cleaning .....	5-2
5.3.1 Cleaning the document cover, document holding pad, and document bed .....	5-2
5.3.2 Cleaning the ADF .....	5-3
5.4 Consumables/Periodical replacement parts .....	5-4
5.4.1 Parts number and replacement cycle .....	5-4
5.4.2 Replacing pad ASY .....	5-4
5.4.3 Replacing pick roller .....	5-5
 <b>CHAPTER 6 TROUBLESHOOTING</b> .....	 6-1
 <b>APPENDIX A</b> .....	 A-1
A.1 Installation Specifications .....	A-1
A.2 External Dimensions .....	A-2
 <b>APPENDIX B</b> .....	 B-1
B.1 Test mode for maintenance .....	B-1
 <b>APPENDIX C</b> .....	 C-1
C.1 Option .....	C-1
C.2 IPC-2/CMP-2 option board installation .....	C-1

# FIGURES

	page
2.1 Received components .....	2-1
2.2 M3096EX/GX parts names .....	2-2
2.3 M3096EX/GX Indication panel .....	2-4
2.4 M3096EX (LCD model) operator panel .....	2-4
3.1 SCSI-ID setting .....	3-6
4.1 Flatbed reading .....	4-3
4.2 Removing the document cover .....	4-4
4.3 ADF paper chute setting .....	4-7
4.4 Loading the document .....	4-9
5.1 Removing jammed documents .....	5-1
5.2 Cleaning the document cover, document holding pad, and document bed .....	5-2
5.3 Cleaning the ADF .....	5-3
5.4 Pick Roller replacement .....	5-5
5.5 Move the Retaining spring .....	5-6
5.6 Slide the Pick Roller .....	5-6
5.7 Remove the Pick Roller .....	5-6
A.1 External dimensions .....	A-2

# TABLES

	page
1.1 The differences between the M3096EX and the M3096GX.....	1-1
3.1 SCSI-ID setting .....	3-6
6.1 Check items .....	6-1
A.1 Installation specifications .....	A-1
B.1 LED at an error .....	B-2

# CHAPTER 1 PREFACE

This manual describes how to operate the M3096EX and M3096GX image scanners. An image scanner optically reads image information from a document and outputs the information to the host system. The differences between the M3096EX and the M3096GX image scanners are listed in table 1.1.

**Table 1.1 The differences between the M3096EX and the M3096GX**

Model number	Interface	Shipping models	Image size	Automatic document feeder
M3096EX (LCD model (Standerd model*))	RS232C + VIDEO	North America	A3 size or double-letter size	Yes Max. 50 pages (A4)
		Europe		
M3096GX (Standerd model)	SCSI2	North America		
		Europe		

\*Standerd model is the model which does not have LCD on operator panel.

This manual should be read before operating the image scanner to ensure correct operation.

## Note on Copyright Act

This document cannot be reproduced or copied for any use other than private without the author's permission.



**This page is intentionally left blank.**

## CHAPTER 2 COMPONENTS

- 2.1 Checking the Components
- 2.2 Part Names and Functions
- 2.3 Indication Panel Functions
- 2.4 Operator Panel Functions

After unpacking image scanner, confirm that all the components have been received. This section describes the components of the image scanner and their functions.

### 2.1 Checking the Components

These high precision components must be handled with care. Confirm that all the components shown in figure 2.1 have been received. If any component is missing, please contact your local Fujitsu sales person.

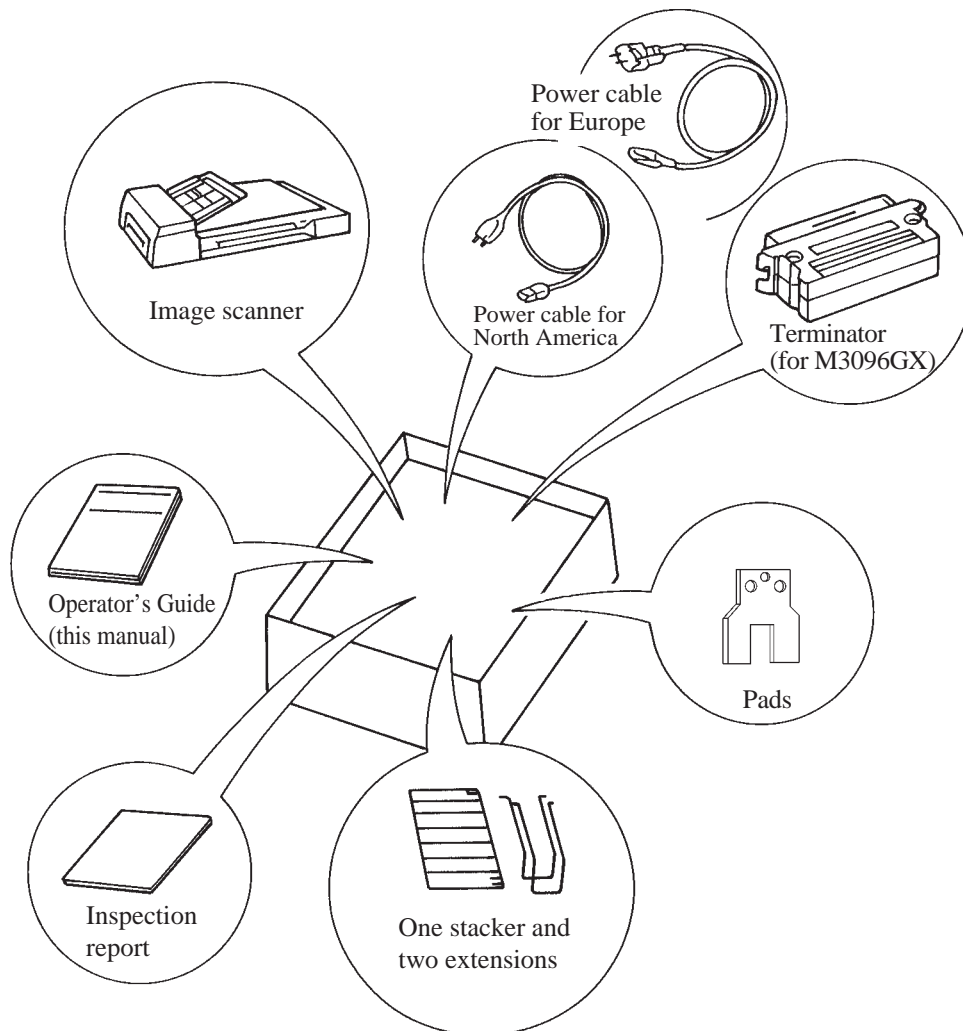

Figure 2.1 Received components

## 2.2 Part Names and Functions

This section shows the exterior view of image scanner. This section also provides names of each part and describes their functions.

### 2.2.1 Exterior view of image scanner

The image scanner can read a document of A3 or double-letter size at maximum.

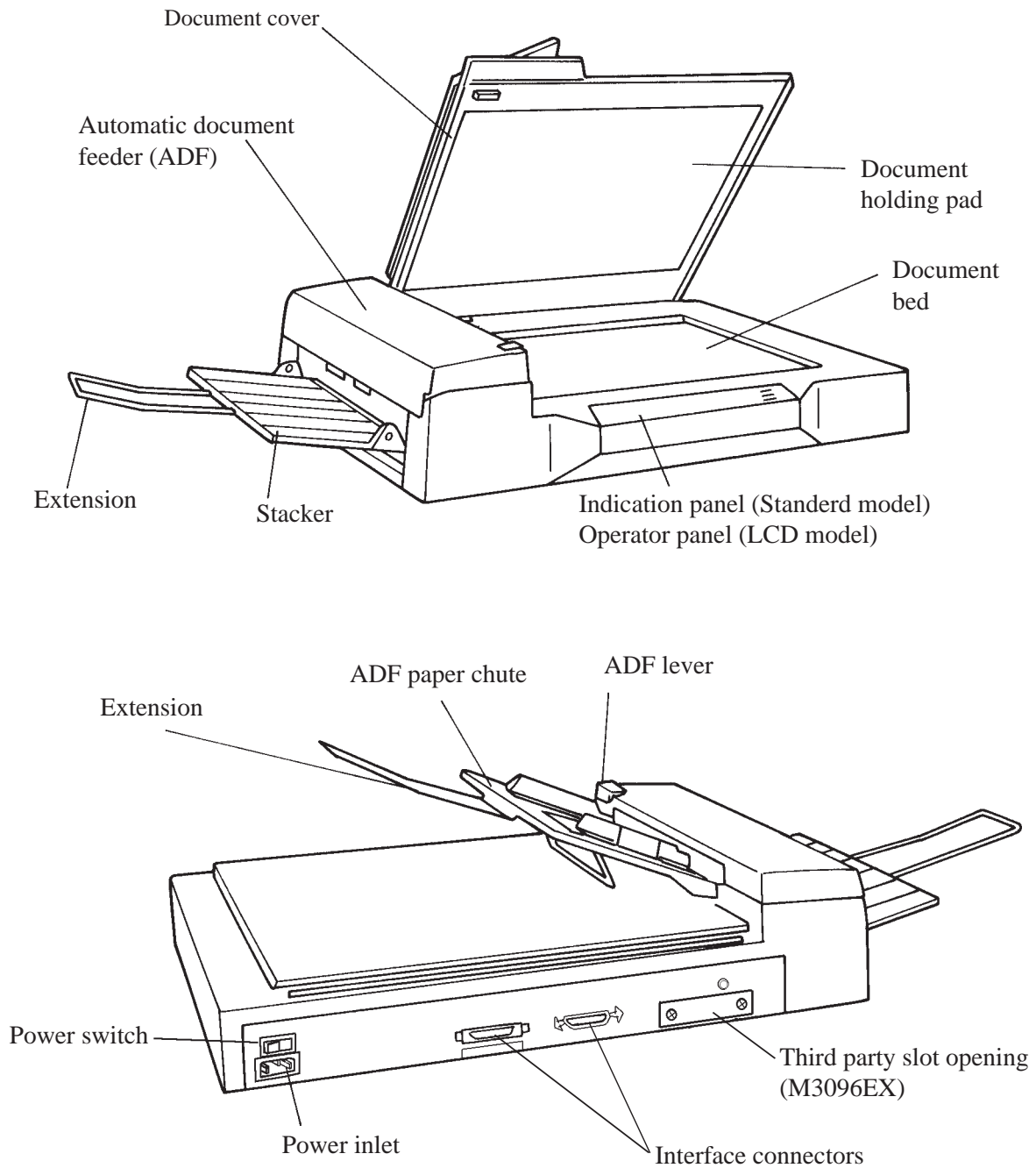

Figure 2.2 M3096EX/GX parts names

### 2.2.2 Functions of each part

Document cover:	Closed over and holds a document to be read.
Document bed:	A document to be read is placed on the bed also called Flatbed (FB).
Document holding pad:	Presses a document to the document bed.
Automatic document feeder (ADF):	Automatically feeds documents to the reading position.
Stacker:	Stacks the read documents.
Extension:	Keeps the stacked documents from overhanging.
Power switch:	Turns the power on or off.
Indication panel:	The indication panel indicates the status of the scanner.
ADF paper chute:	Holds the documents to be fed by the automatic document feeder.
ADF lever:	Opens or closes the automatic document feeder to remove documents jammed in the feeder.
Power inlet:	To be connected to an AC power outlet with the power cable.
Interface connectors:	To be connected to the host system with interface cables.
Third party slot opening:	Reserved. (M3096EX)

## 2.3 Indication Panel Functions (standard model)

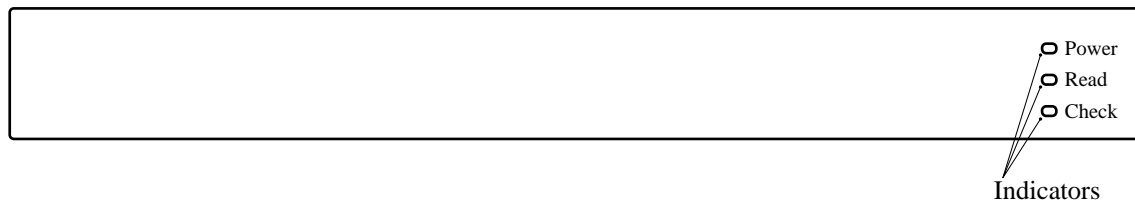

Figure 2.3 M3096EX/GX Indication panel

### 2.3.1 Indicators

The meaning of each indicator is as follows:

Power indicator (Green):

Lights to indicate the power is on.

Read (reading in progress) indicator (Green) :

Lights to indicate reading is in progress.

Check (device check) indicator (Yellow):

Lights if a device error occurs which may result in a service call. This indicator blinks if a document is jammed in the automatic document feeder. This indicator turns off when the jammed documents are re-moved from the feeder and the feeder is closed.

This indicator blinks in four seconds period if the ADF cleaning is necessary. (See 5.3.2)

## 2.4 Operator Panel Functions (LCD model)

The operator panel has indicators and a liquid crystal display screen for displaying image scanner status. The operator panel also has operation buttons.

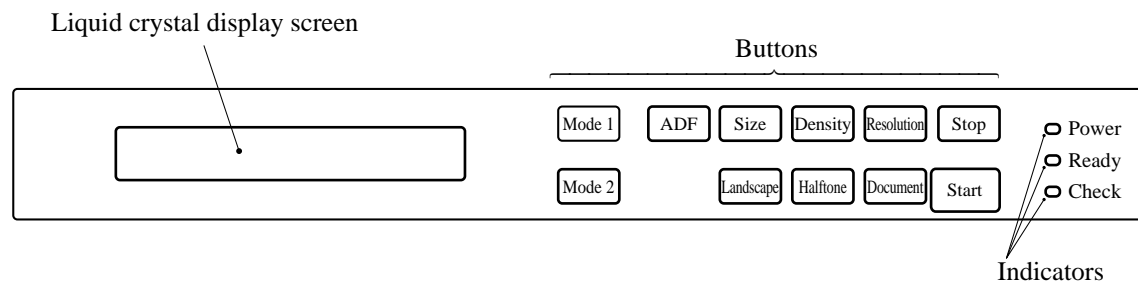

Figure 2.4 M3096EX (LCD model) operator panel

## 2.4.1 Indicators

The meaning of each indicator is as follows:

Power indicator (Green):

Lights to indicate the power is on.

Read indicator (Green) :

In manual mode, when this lamp is lit, it indicates that the start switch is enabled.

Check (device check) indicator (Yellow):

Lights if a device error occurs which may result in a service call. This indicator blinks if a document is jammed in the automatic document feeder. This indicator turns off when the jammed documents are removed from the feeder and the feeder is closed.

## 2.4.2 Buttons and liquid crystal display screen

The function of each button is as follows:

Start button:

Read operation can be started in either manual or automatic mode. To start reading in manual mode, press this button while the ready indicator is lit.

- Manual mode: Reading is started by the start button.
- Automatic mode: Reading is started by a command from the host system.

Stop button:

This button is effective regardless of whether the scanner is in manual or automatic mode. Press this button to stop the read operation. When this button is pressed, the image scanner operates as follows:

- Reading in flatbed mode: Reading is immediately stopped.
- Reading in ADF mode: Reading is immediately stopped and documents being fed are ejected to the stacker. After cleaning a jam, press the stop button to clear the “Paper Jam” message displayed on the screen. The ready screen will then be displayed to indicate that the scanner is ready to read.

### 2.4.3 Liquid crystal display screen

The screen has two message lines. The current read mode status is displayed in the upper line, and messages and the modes set by the buttons are displayed in the lower line.

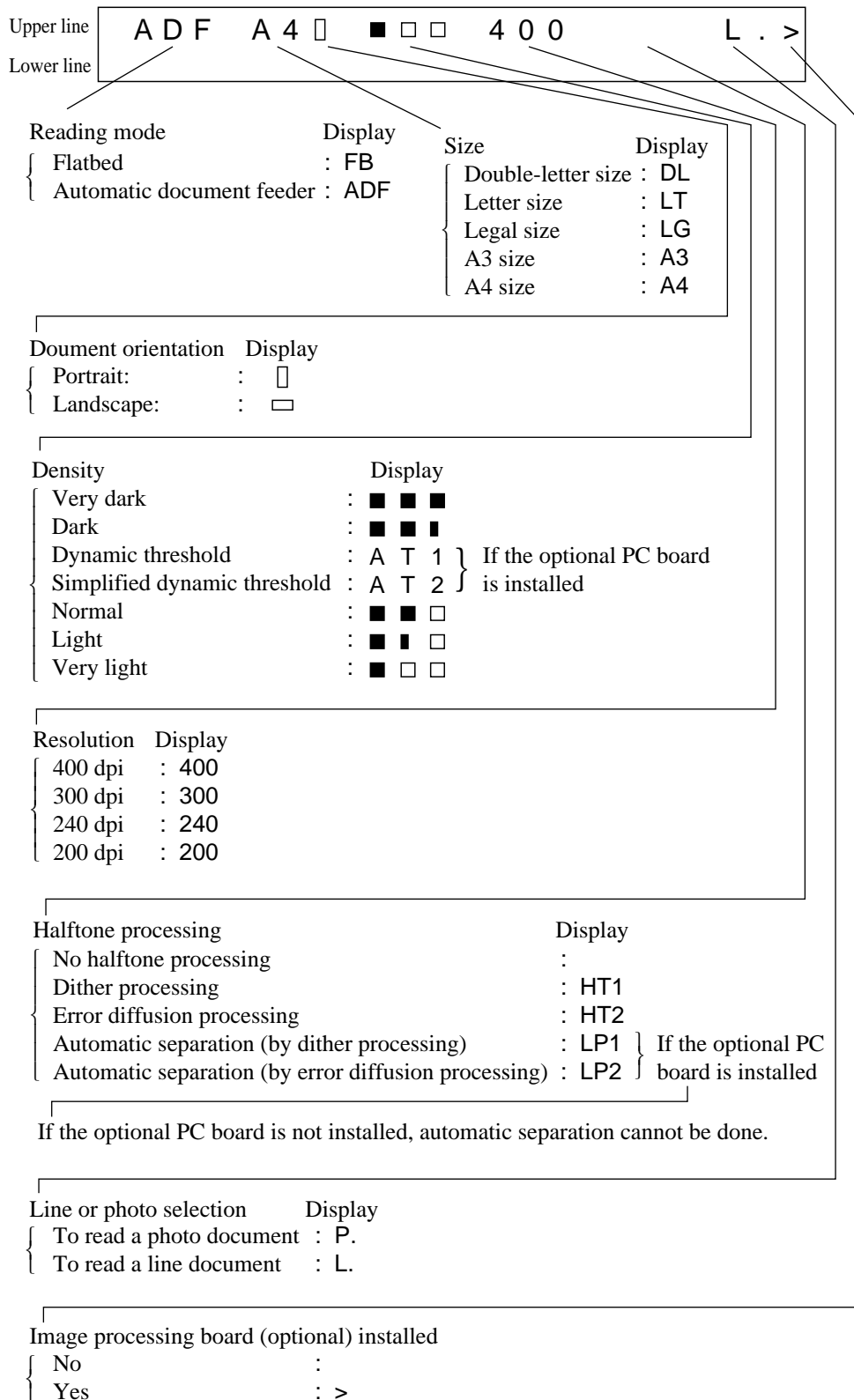

The ADF, size, density, resolution, landscape, half-tone, document, and mode 1 and 2 buttons described below are effective unless otherwise specified by the host system.

**Automatic document feeder (ADF) button:**

Selects whether to feed documents automatically by ADF or manually on the flatbed. When this button is pressed, the lower line is displayed as shown in Screen 1. Each time this button is pressed, “FB” or “ADF” starts blinking in turn, and the read operation status displayed in the upper line changes accordingly.

Screen 1 — The upper line shows a typical example.

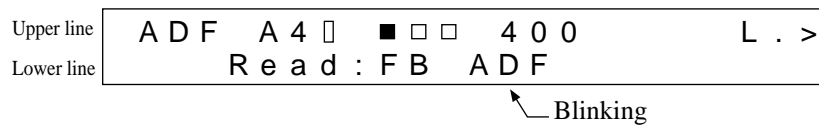

**Size button:**

Selects a document size. When this button is pressed, the lower line is displayed as shown in Screen 2. Each time this button is pressed, “DLT”, “LT”, “LG”, “A3”, or “A4” starts blinking in turn, and the size displayed on the upper line changes accordingly.

Screen 2 — The upper line shows a typical example.

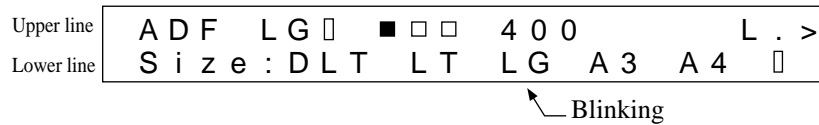

If the direction indicated on the upper line is “□”, only “LT” or “A4” can be selected.



**Density button:**

Selects a density for the read operation. When this button is pressed, the lower line is displayed as shown in Screen 3. Each time this switch is pressed, the blinking part in the lower line changes, and the density indicated on the upper line changes according to the blinking part.

Screen 3 — The upper line shows a typical example.

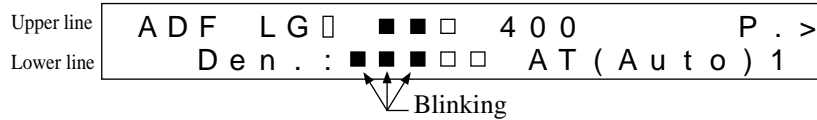

The lower line is displayed as shown below. (See the beginning of this section for the upper line.)

Blinking order	Display (lower line)	Explanation
	■ ■ ■ ■ ■	— Very dark
	■ ■ ■ ■ □	— Dark
If the optional PC board is installed:	{ AT ( Auto ) 1	— Dynamic threshold
	{ AT ( Auto ) 2	— Simplified dynamic threshold
	■ ■ ■ □ □	— Normal
	■ ■ □ □ □	— Light
	■ □ □ □ □	— Very light

**Resolution button:**

Selects a resolution for the read operation. When this button is pressed, the lower line is displayed as shown in Screen 4. Each time this button is pressed, “400”, “300”, “240”, or “200” starts blinking in turn, and the resolution indicated on the upper line changes accordingly.

Screen 4 — The upper line shows a typical example.

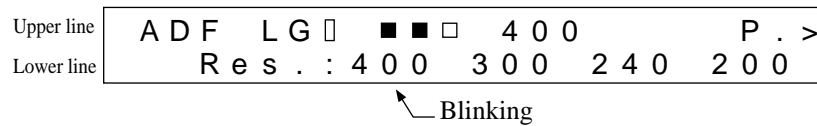

**Landscape button:**

Specifies whether reading is done in landscape or portrait mode. When this button is pressed, the lower line is displayed as shown in Screen 5. Each time this button is pressed, the blinking part changes in turn, and the mode indicated on the upper line changes accordingly.

Screen 5 — The upper line shows a typical example.

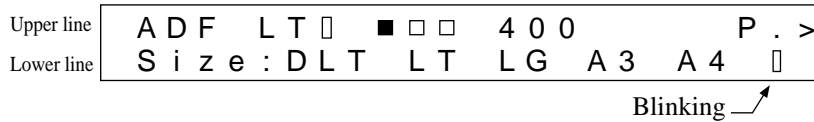

Explanation:

Display

: Landscape mode. This mode can be selected only if the document size displayed on the upper line is LT or A4.

: Portrait mode.

**Halftone button:**

Specifies whether to perform halftone processing (dither or error diffusion). When this button is pressed, the lower line is displayed as shown in Screen 6. Each time this button is pressed, the blinking part changes in turn, and the halftone indication on the upper line changes accordingly.

Screen 6 — The upper line shows a typical example.

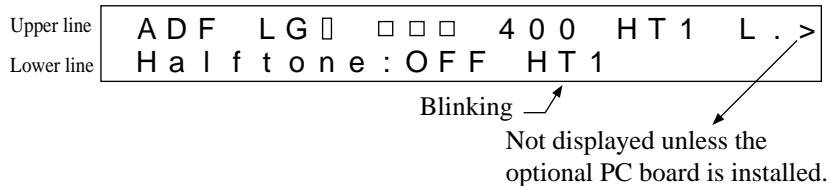

Explanation:

Blinking order	Display (lower line)	Explanation	
	“OFF” blinking	: Line Art (Halftone Processing off)	
	“HT1” blinking	: Halftone processing (dither)	} Select one of these settings to read data such as photographs, illustrations, or colored maps.
	“HT2” blinking (changed from HT1)	: Halftone processing (error diffusion)	
	“LP1” blinking (changed from HT2)	: Automatic separation (dither)	} If photographs and characters are mixed in a document, the characters are read clearly and the photographs are read in halftone. This setting is only available if the optional PC board is installed.
	“LP2” blinking (changed from LP1)	: Automatic separation (error diffusion)	

**Document button:**

Selects the type of document. When this button is pressed, the lower line is displayed as shown in Screen 7. Each time this button is pressed, “LINE” or “PHOTO” starts blinking in turn, and the document selection indication displayed on the upper line changes accordingly.

Screen 7 — The upper line shows a typical example.

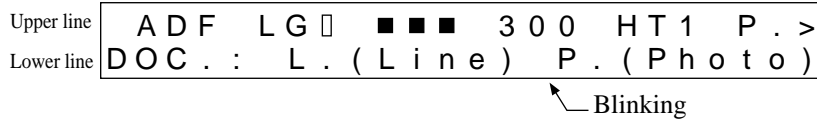

**Explanation:**

Display (lower line)

Explanation

P.(Photo) : For light adjustment or when there is a dark background color on the document, select P. (Photo).

L.(Line) : Select this setting to read line drawings.

NOTICE :When L. (Line) is selected, the top 3-mm part of the read area should be left blank (grounding color) by specifying a drop-out color.

**Mode 1 and 2 button:**

These buttons are used for maintenance.

## 2.4.4 Messages

### Error messages (temporary errors)

If a temporary error occurs in the scanner, one of the following messages is displayed.

P a p e r   E m p t y

This message is displayed if there is no more paper on the ADF paper chute during a read operation in ADF mode. Fill the ADF paper chute with paper. To enable the read operation, press the stop button.

P a p e r   J a m

This message is displayed if a document is jammed in the ADF. See section 5.1 for removing jammed documents.

A D F   -   C o v e r   O p e n

This message is displayed if the ADF is not closed completely. Close the ADF completely, and enable the read operation.

### **Error messages (device errors)**

One of the following messages is displayed if an error occurs in the scanner. If one of the following error messages is displayed, turn the power off and then on again. If the same message is displayed, contact your service representative.

Optical Alarm

Mechanical Alarm

Fuse Alarm - Lamp

Fuse Alarm - FB Motor

### **Operation status messages**

Operation status is displayed as shown by the following messages:

Warming - up Now!!

The power is on.

Now Reading!

Reading is in progress.

ADF LG  400 HT2 L.>  
Ready

The scanner is ready for operation in the manual mode.  
Press the start button to start the read operation.

Please clean Pick-roller

## CHAPTER 3 INSTALLATION AND CONNECTIONS

- 3.1 Precautions
- 3.2 Removing the Carrier Fixing Bracket
- 3.3 Connections
- 3.4 Mounting the Stacker
- 3.5 SCSI-ID Setting

This chapter explains how to install and connect the image scanner.

### 3.1 Precautions

Do not install the image scanner in the following places and environments. See the appendix A.1 “Installation Specifications” for the information such as size of installation space.

---

---

Place the scanner away from electrical noise sources and strong magnetic fields. If the image scanner is used near an air conditioner, copying machine, or TV set, the scanner may operate incorrectly.

---

---

---

---

Do not install the scanner in a humid, dusty, or damp places. These environments may shorten scanner life or cause hardware failures. Do not place the image scanner where liquid spills may occur. Place it on a flat and even surface.

---

---

---

---

Keep the scanner out of the sun and away from heaters. These environments may shorten scanner life or cause hardware failures.

---

---

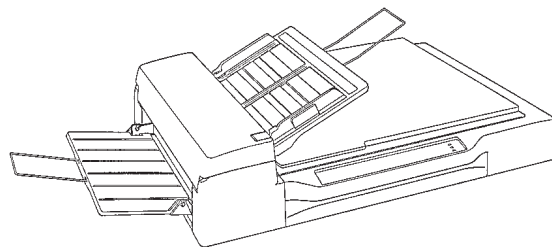

---

---

Do not install the scanner in a place where vibrations may occur. This environment may cause hardware failures or may cause the scanner to operate incorrectly.

---

---

#### CAUTION

Place the image scanner on a level surface. Place the image scanner so that the rubber pads are secured on a flat and solid desktop.

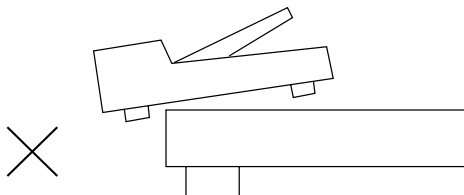

---

---

Be aware of static electricity. If static electricity is generated, the scanner may operate incorrectly. Be sure that the flooring and the desk are made of materials that do not generate static electricity.

---

---

### 3.2 Removing the Carrier Fixing Bracket

To keep the scanner from being damaged during shipping, the carrier unit is fixed with a bracket. After placing the carrier unit at the installation place, remove this bracket as explained below.

- ① Place the image scanner on the edge of the desk top so that the left side (where ADF is placed) of the scanner extends from the desk top. Do not set the image scanner upside down or on its side.

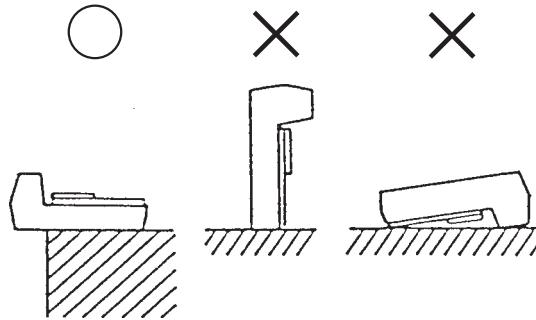

- ② Remove the carrier fixing bracket from position ①. Then install the carrier fixing bracket at position ②.

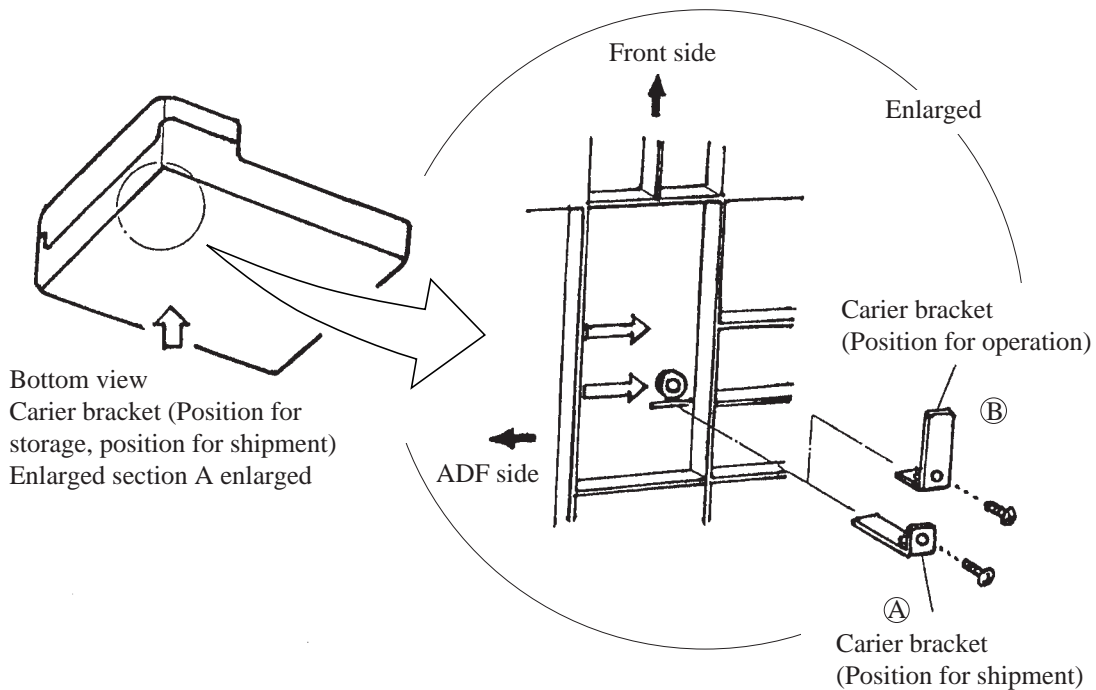

### 3.3 Connections

Connect the image scanner using the following procedure.

- ① Set the power switch to off.

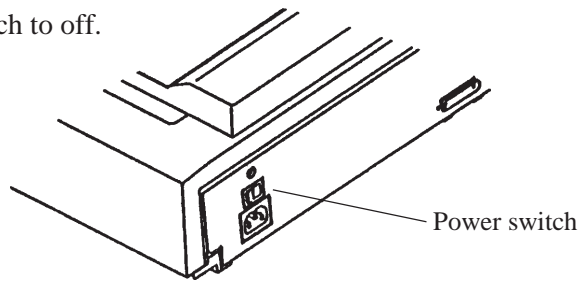

- ② Connect the power cable.

Connect the power cable to the power inlet on the back of the image scanner.  
Connect the other end of the power cable to a power outlet.

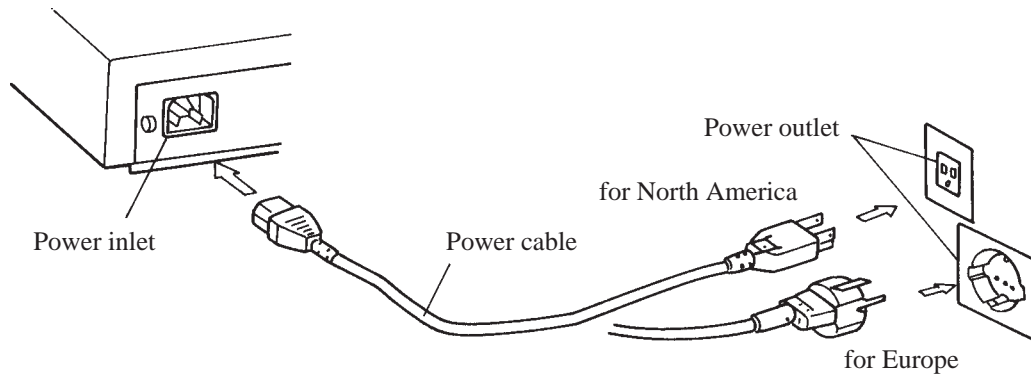

- ③ Connect the interface cables (for M3096EX).

Connect the interface cables to the interface connectors and fasten the cables with catches and screws as shown below.

Connect the other end of each interface cable to the host computer.

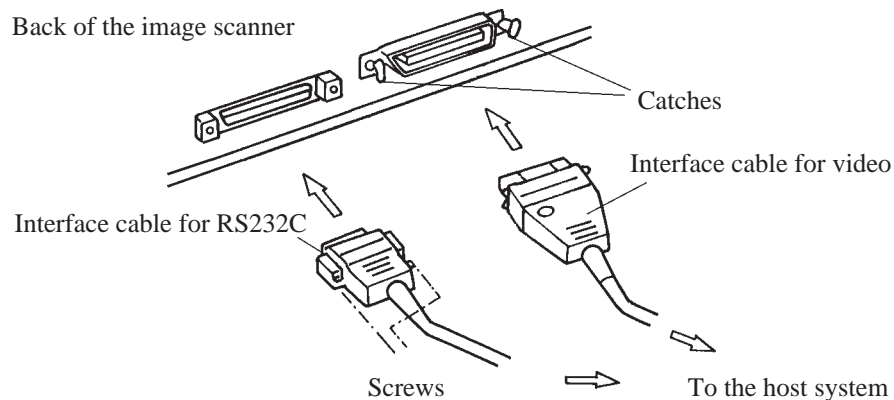



(M3096GX)

Connect the interface cables to the interface connectors and fasten the cables with the catches. Connect the other ends of the cables to the host system. If the image scanner is at the terminal side, connect the terminator.

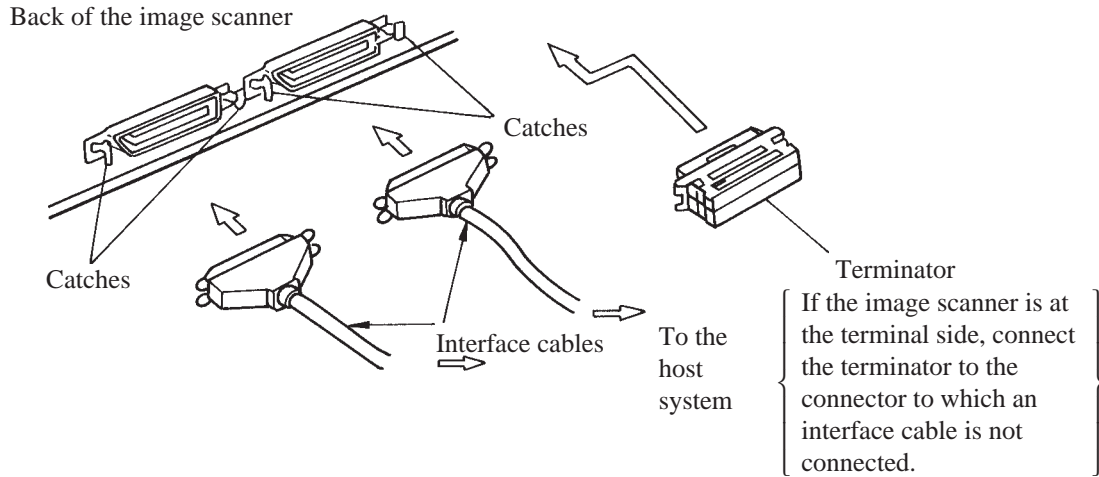

### 3.4 Mounting the Stacker

Mount the stacker and extensions using the following procedure.

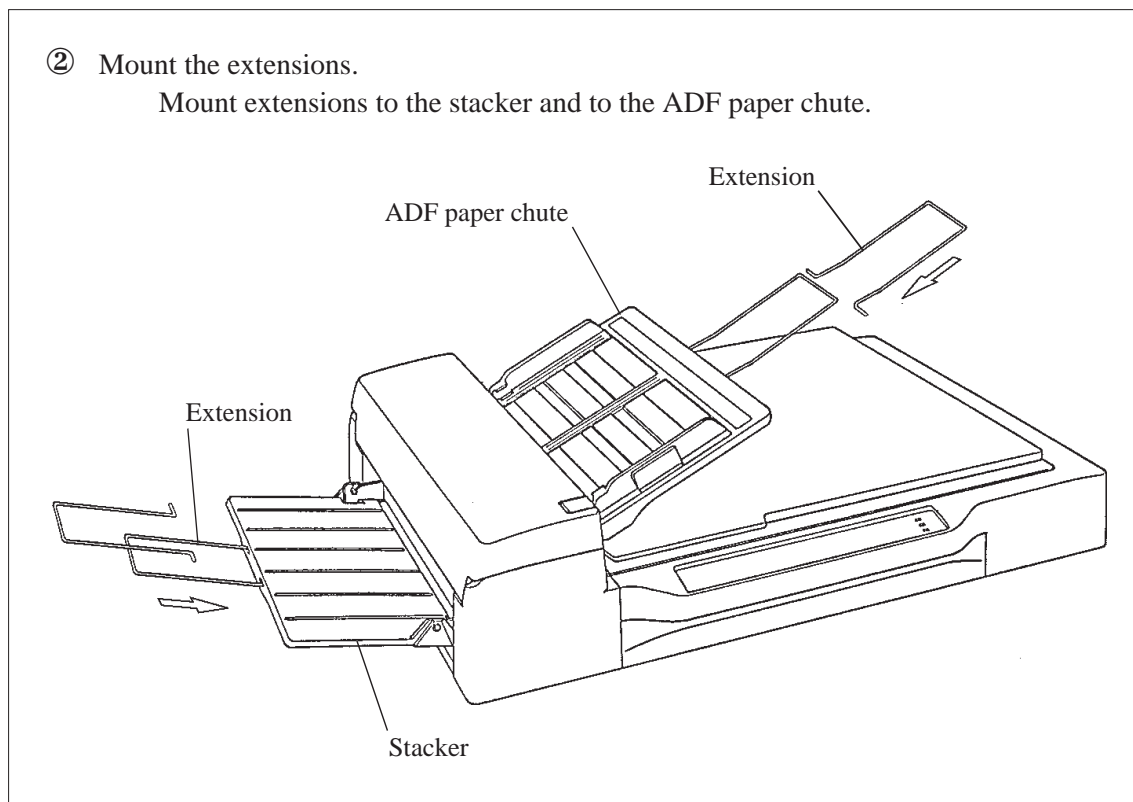
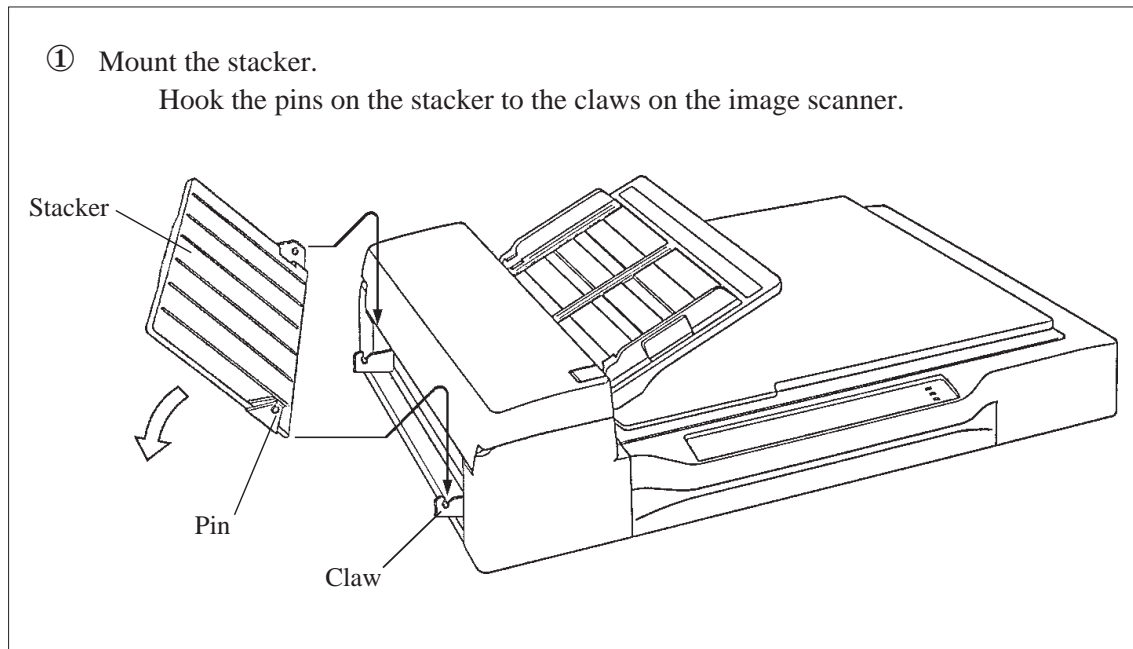

### 3.5 SCSI-ID Setting

Use the address switches to set the device address. After the setting turn the scanner on.

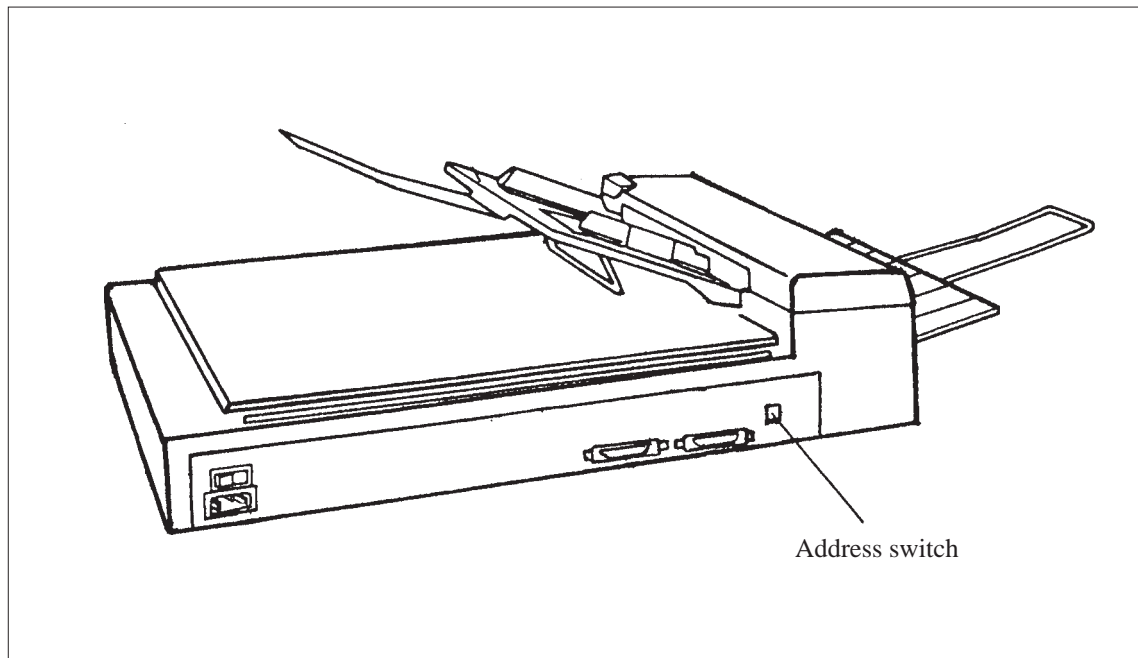

**Figure 3.1 SCSI-ID setting**

**Table 3.1 SCSI-ID setting**

ID	Contents
0 to 7	Available
8, 9	No Operation

\* When the scanner is terminated device, the termination connector must be connected on one side of the connectors.

# CHAPTER 4 OPERATIONS

- 4.1 Turning on the Power
- 4.2 Reading a Document in Flatbed Mode
- 4.3 Reading Documents in ADF Mode

Documents can be read in the flatbed mode or automatic document feeder (ADF) mode. In the flat-bed mode, each document is placed on the document bed and is read one by one. In ADF mode, documents are fed and read automatically.

This section explains how to turn on the power and how to read documents.

## 4.1 Turning on the Power

This section explains how to turn on the power.

Press "I" on the power switch. When the power is turned on, the power indicator is lit.

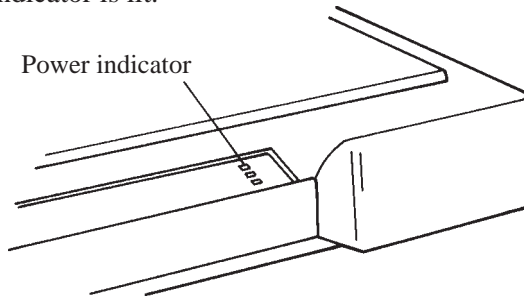

Press "O" on the power switch to turn off the power.

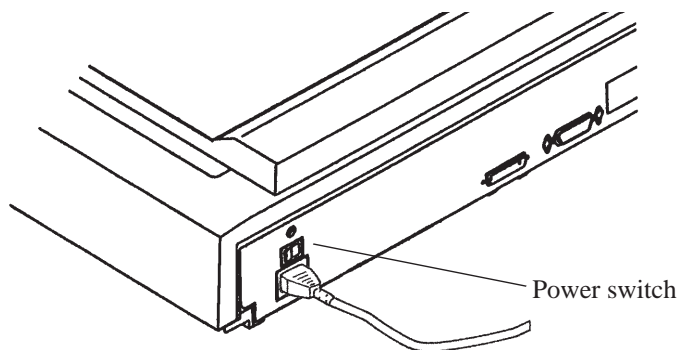

Power OFF



Power ON

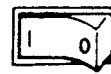

## 4.2 Reading a Document in Flatbed Mode

This section explains how to read a document placed on the document bed.

### 4.2.1 Reading a standard-size document

If the size of the document is smaller than the document bed, read the document using the following procedure:

- ① Open the document cover.
- ② Place the document face down on the document board. Correct any curled or folded parts of the document.
- ③ Position the long side (in landscape mode) or the short side (in portrait mode) of the document to the left side of the document bed.
- ④ Position the left top of the document to the reference mark. If the document is not placed correctly, reading cannot be done correctly.
- ⑤ Close the document cover slowly. If the document cover is closed too quickly, the document may move.
- ⑥ Start the read operation. Do not press on or open the document cover during the read operation.
- ⑦ After reading, open the document cover to remove the document.

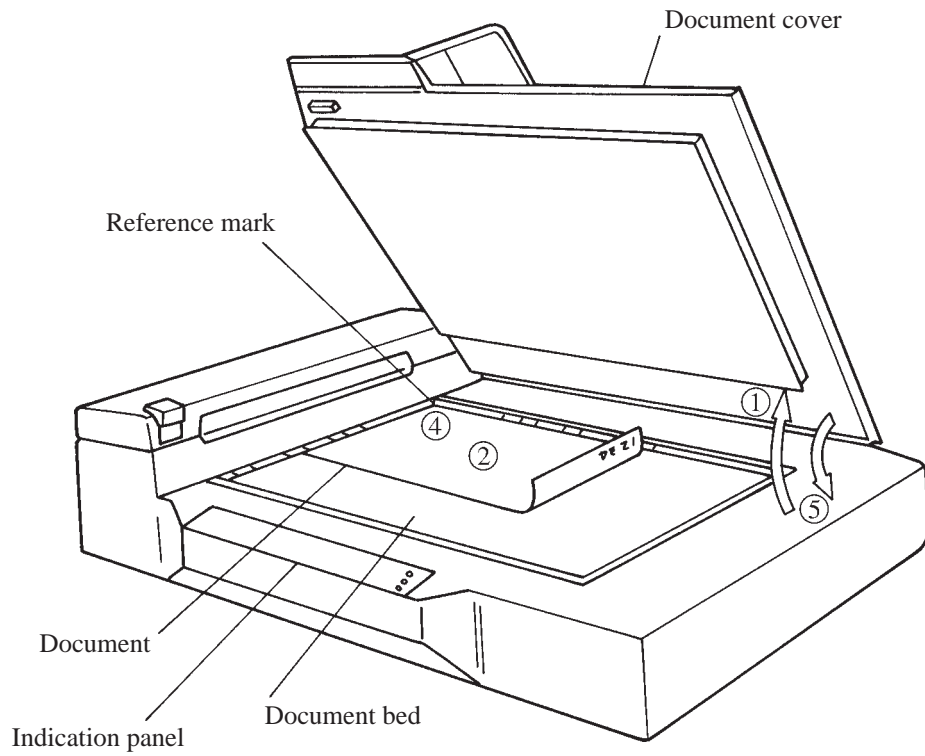

**Figure 4.1 Flatbed reading**

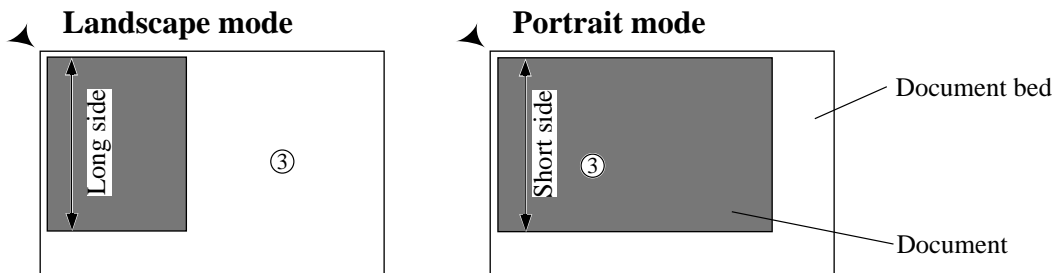

#### 4.2.2 Reading a page from a thick book

To read a page from a thick book, remember the following points:

- ① Do not close the document cover forcibly. Keep the cover open for reading.
- ② Any document parts that are not in contact with the glass will not be read correctly.
- ③ Do not move the document during the read operation.

### 4.2.3 Reading a document larger than the document board

If the size of the document is larger than the document board, read the document using the following procedure:

- ① Open the document cover at an angle of about 80°, then slide the cover to the direction of the arrow to remove it.
- ② Place the document face down on the document bed.
- ③ Place the document cover over the document.
- ④ Read the document.
- ⑤ After the read operation, remove the document, replace the document cover. Mount the document cover to the original position, and close the document cover.

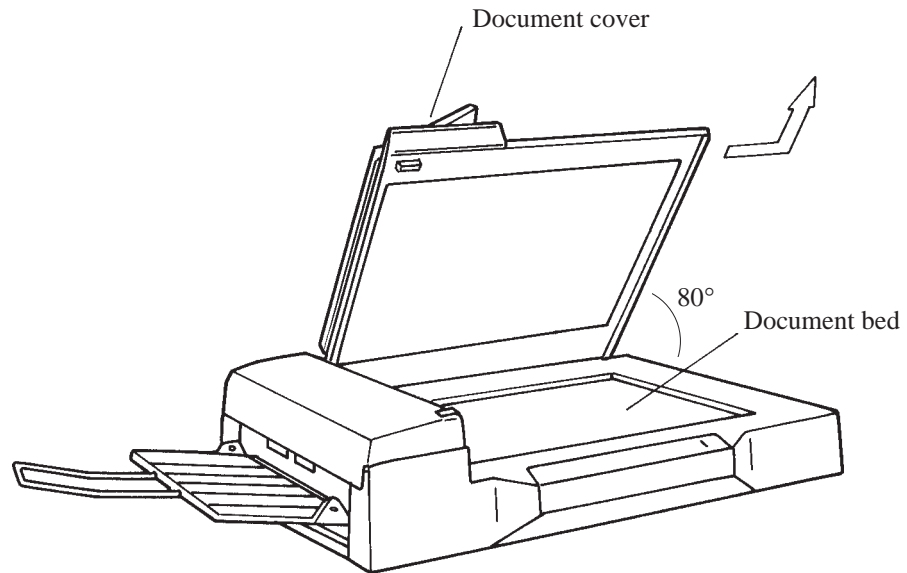

**Figure 4.2 Removing the document cover**

**NOTICE:** Do not remove the document cover for any other purpose.

### 4.3 Reading Documents in ADF Mode

This section explains how to read documents using the automatic document feeder. If the following steps are not closely followed, a feed error may occur.

- ① Check the documents as follows:
  - (a) Paper quality
    - Wood-free paper.
    - PPC paper; Specified by XEROX Corporation.
  - (b) Paper weight
    - 13.91bs to 27.81bs
  - (c) Paper size
    - Letter, Double Letter, Legal, A3, A4, A5, B4, B5
  - (d) Items to avoid
    - The following documents may be hard to read by ADF. Before you start the large quantity reading, check that the document is read appropriately. If the reading is not appropriate, read them by flatbet.
      - Paper with a clip or staple.
      - Paper that has ink which is not dry.
      - Paper thickness is not constant, such as an envelope.
      - Paper that has large rumples or curl. (See NOTICE)
      - Paper that has folds or tears.
      - Tracing paper.
      - Coating paper.
      - Carbon paper.
      - Paper that is smaller than A5 size or larger than A3 width.
      - Items other than paper, such as clothes, metal sheet, or OHP film.
      - Photographic paper.
      - Paper that has perforations on its side.
      - Paper that has a shape other than square.
      - Paper that is very thin.

NOTICE : The important document which shall not be torn must be read by flatbet.

NOTICE : Carbonless papers have the chemical composition which damages the pad and pickroller. Therefore, note the following remarks.

Cleaning : If the miss pick occurs frequently, clean the pad and pickroller in accordance with the section 5.3.2.

Replacement of parts : The life of the pad and the pickroller may be shorter than the case that PPC document is fed. Replacement cycle of the pad and the pickroller may be 100,000 sheets or more if the paper quality is good and cleaning is done well. Before you start the large quantity reading, check the replacement cycle of them and prepare pads and pickrollers.



NOTICE: Paper should be straightened to fit the condition below.

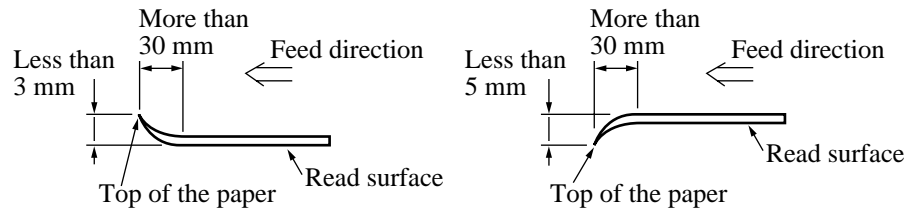

② Switch the paper select lever.

Switch the lever in the following procedures:

- Open the automatic document feeder (ADF) while lifting up the ADF lever.
- Set the paper select lever.  
Plain paper: "NORMAL"  
Heavy paper: "THICK"
- Reset the ADF. (Check that the ADF lever is set at the "NORMAL" position.)

NOTICE: Always reset the paper select lever to "NORMAL" position, unless you feed the thick paper.

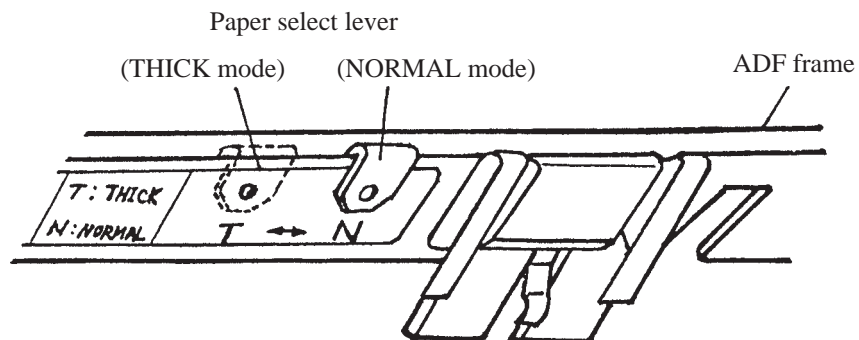
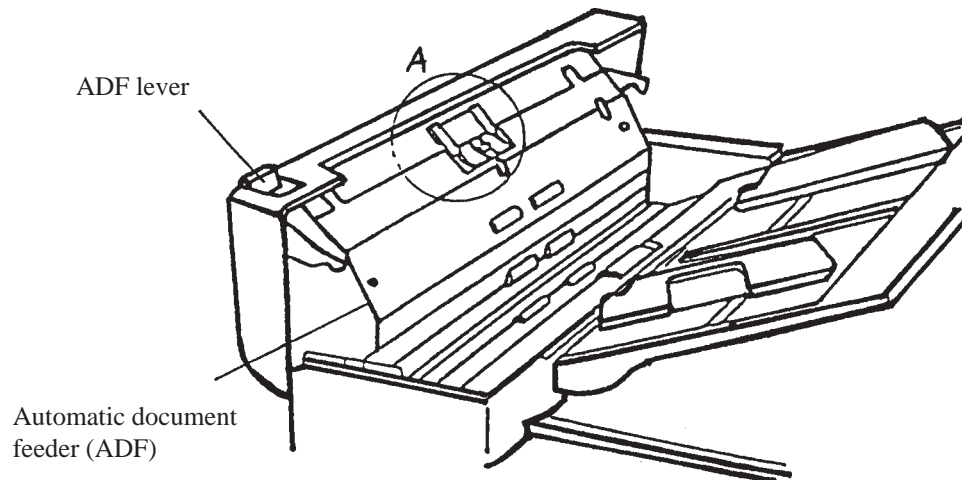

Section A enlarged

③ Pull up the ADF paper chute as follows:

- Hold the document cover with one hand and pull up the ADF paper chute with the other hand to set the shaft in position B.

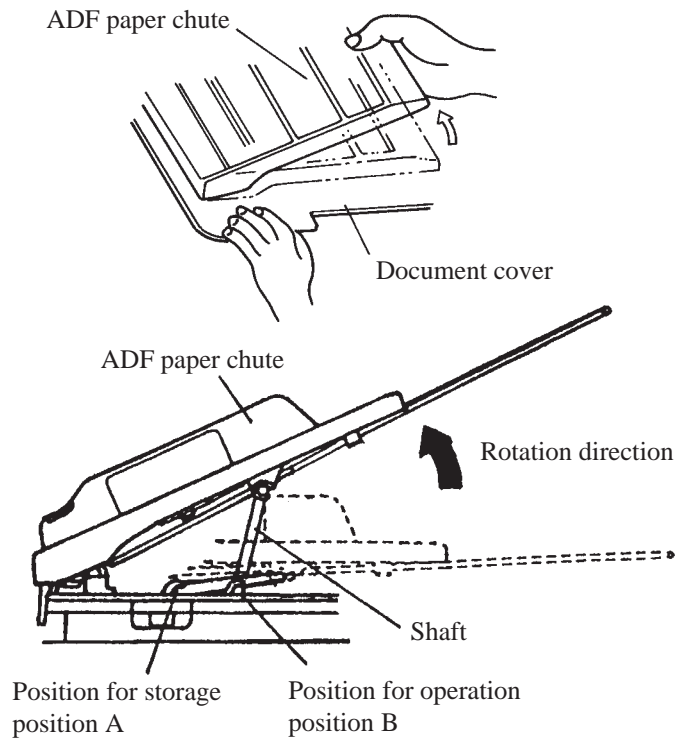

**Figure 4.3 ADF paper chute setting**

④ Fan the documents as follows:

- Take a 15 to 20 mm thickness of documents. Lightly hold both ends with both hands. Bend the documents into an arch as shown below.
- Then hold the documents tightly with both hands, and straighten the documents. The center of documents swell and air is introduced between the documents.
- Repeat this operation two or three times.
- Turn the documents 90°, and repeat the operation again.

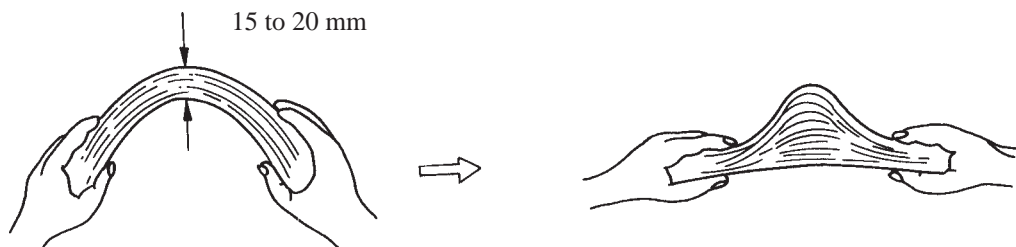

- ⑤ Take documents to be placed in the ADF paper chute. The thickness of the documents to be placed in the ADF paper chute is limited depending on the size of the documents as follows:

A4 or letter size or smaller: 4 mm or less

Size larger than A4: 2 mm or less

- ⑥ Angling the documents

Angle the document edges as follows:

- Place the documents face down with the top to the left as shown in A. The long side is the top for landscape mode and the short side is the top for portrait mode.
- Lift the documents holding the both ends with both hands.
- Hold the documents tightly with your left hand and bend the documents as shown in B.
- Grip tightly with your right hand, loosen the grip of your left hand, and straighten the documents as shown in C.
- Repeat these operations until the top is angled 20° or less as shown in D.

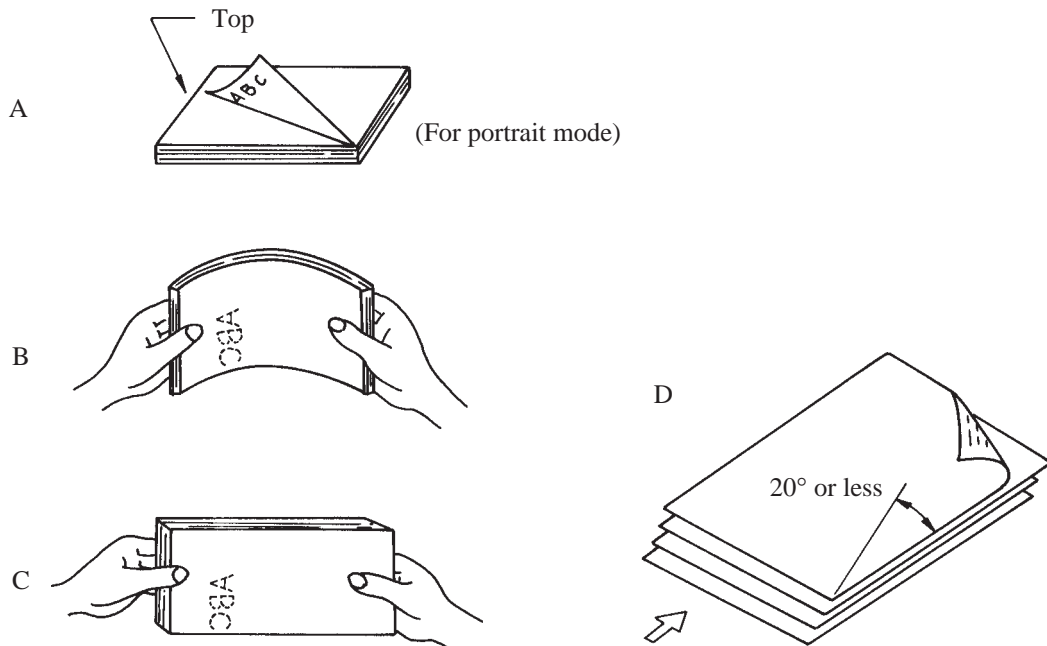

- ⑦ Open the right and left guides of the ADF paper chute about 5 mm wider than the document width.
- ⑧ Place the documents face down onto the ADF paper chute with the top edges facing the automatic feeder hole.
- ⑨ Adjust the guides to the document sides. Skewing may occur if there is a gap between the guides and documents.
- ⑩ Slide the documents down until they touch the far end of the automatic feeder opening. If the documents hit the far end hard, two or more pages may be fed at once. Make sure that the upper end of documents are not turned.
- ⑪ Start the read operation. If a wrong document size or mode (portrait or landscape) is selected, the document may not be read entirely.

**NOTICE:**

Unless 3 mm of the leading edge of forms are not white or drop-out color, set the document type to “Photo.”

- ⑫ After reading, remove the documents from the stacker.

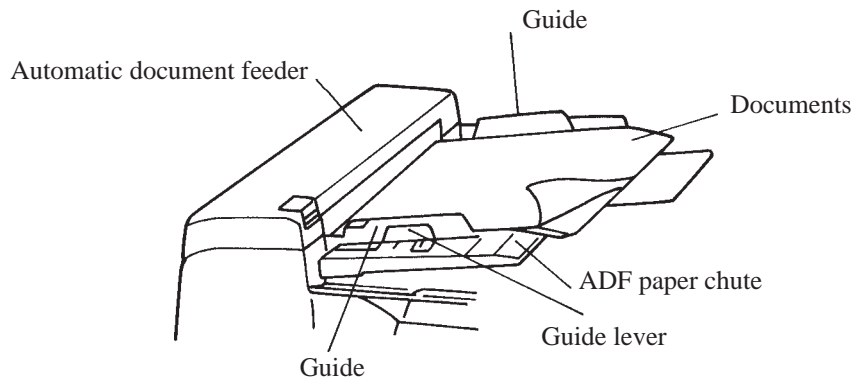

**Figure 4.4 Loading the document**

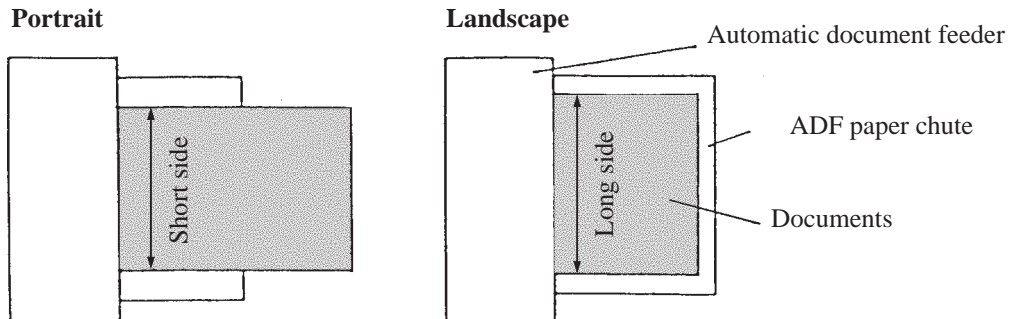

**This page is intentionally left blank.**

## CHAPTER 5 MAINTENANCE

- 5.1 Removing Jammed Documents
- 5.2 Notes on Daily Use
- 5.3 Cleaning
- 5.4 Consumables/Periodical replacement parts

This section explains how to remove jammed documents, and provides notes on daily use and cleaning.

### 5.1 Removing Jammed Documents

If documents jam while being fed by the ADF, remove the jammed documents as follows:

- ① Remove the documents from the ADF paper chute.
- ② Pulling up the ADF lever, open the automatic document feeder.
- ③ Remove the jammed documents.
- ④ Close the ADF until the ADF lever locks.

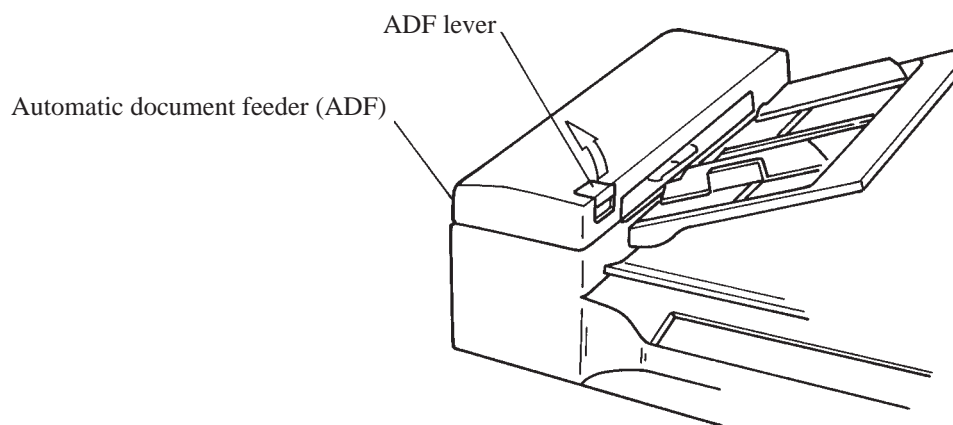

**Figure 5.1 Removing jammed documents**

## 5.2 Notes on Daily Use

Note the following points on daily use:

### NOTICE

- Do not look directly at the light source during the read operation. Keep the document cover in place.

### NOTICE

- See Section 5.3 “Cleaning”, to clean the document cover, document holding pad, document bed, and the automatic document feeder. Especially, clean the automatic document feeder (ADF) periodically. For the cleaning cycle, see Section 5.3.2, “Cleaning the ADF.”

## 5.3 Cleaning

This section explains how to clean the image scanner.

### 5.3.1 Cleaning the document cover, document holding pad, and document bed

- Use a dry cloth or a cloth with a neutral cleanser to remove dirt from the document cover, document holding pad, and document bed. Do not use organic solvents such as a thinner.
- Make sure that no liquid enters the scanner from the edges of the document bed glass.

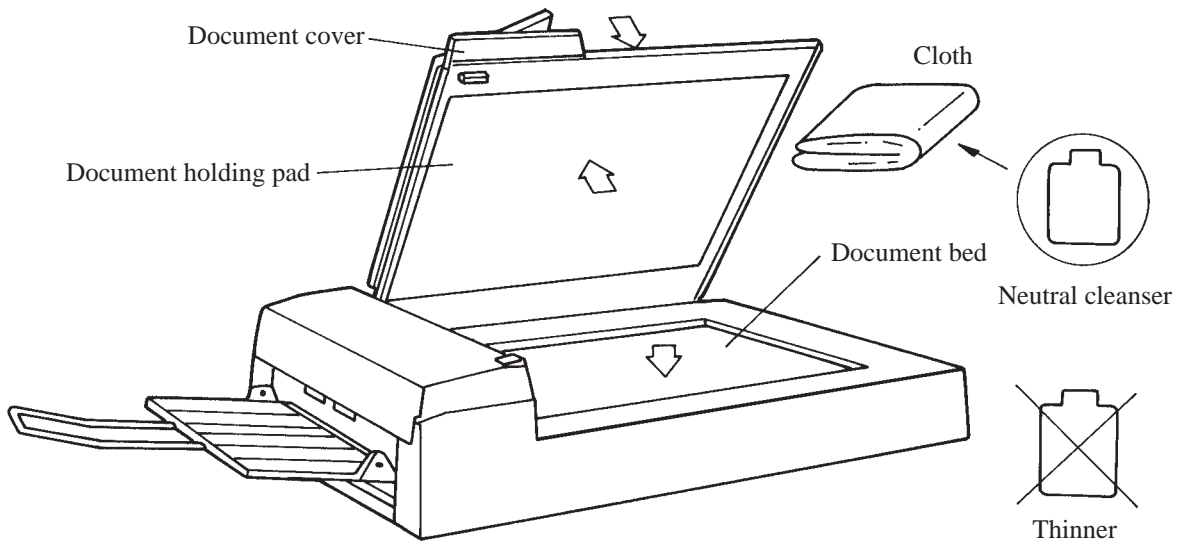

**Figure 5.2** Cleaning the document cover, document holding pad, and document bed

### 5.3.2 Cleaning the ADF

Clean the automatic document feeder (ADF) once every 5,000 pages. The cycle depends on the types of documents used (paper quality, a level of toner fusing on paper).

- ① Pull the ADF lever up to open the ADF.
- ② Use the dry cloth or a cloth with ethyl alcohol to softly remove dirt and dust as follows.

Pad: Wipe the pad in a downward direction (indicated by the arrow). Be careful not to hook the pick spring when wiping.

Glass: Wipe the glass lightly.

Pick roller : Wipe the roller softly. Be careful not to damage the surface of the roller.

Feed roller and coupled feed roller: Wipe the rollers softly. Be careful not to damage the surface of the rollers.

Ejection roller and coupled ejection roller: Wipe the rollers softly. Be careful not to damage the surface of the rollers.

Sheet guide (white part): Wipe the sheet guide softly.

- ③ Close the ADF to lock the ADF lever.

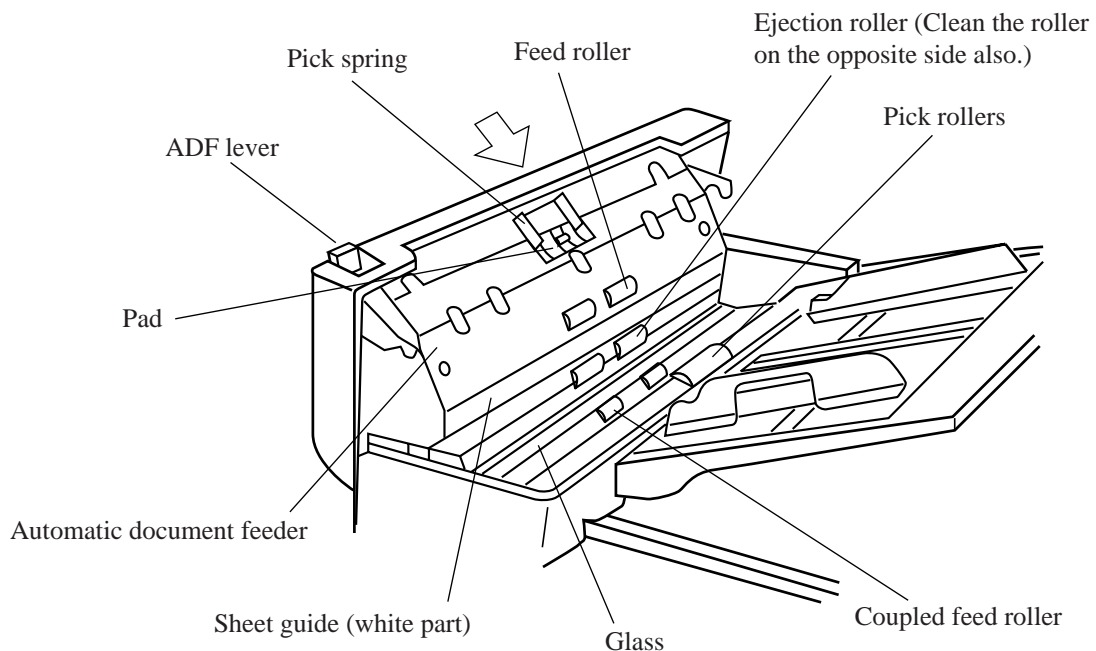

Figure 5.3 Cleaning the ADF



## 5.4 Consumables/Periodical replacement parts

### 5.4.1 Parts number and replacement cycle

Customer is responsible to change these items periodically.

No.	Part name	Part number	Replacement cycle
1	Pad ASY	PA02201-0020	Every 100,000 pages or annually (*1)
2	Pick roller	PA02201-0025 (*2)	Every 200,000 pages or annually (*1)

\*1: These replacement cycle may vary by the paper quality and cleaning result. When PPC paper is used, replacement cycle may be 300,000 sheets or more by good cleaning. Before you start the large quantity reading, evaluate the replacement cycle and prepare pads and pickrollers.

\*2: This part may not be provided in some countries due to the conformability of safety regulation. Before the order of the pick roller, contact your sales agent or Fujitsu service representative.

### 5.4.2 Replacing pad ASY

- ① Lift up the ADF lever and open the ADF.
- ② Insert a coin in the slot or hold the both sides of the pad ASY, then slide it to the direction of the arrow to remove the pad.

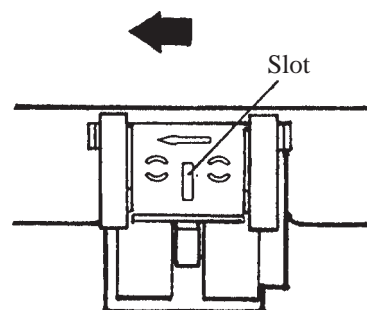
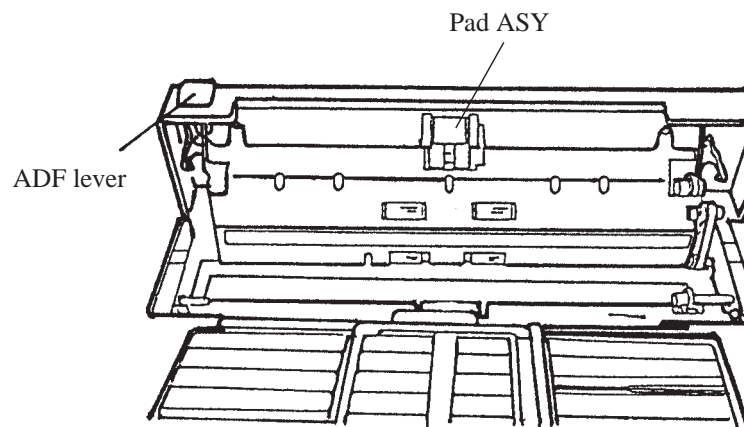

- ③ Insert the pad assembly into the ADF frame hole (the bigger one), slide the assembly to the direction of the arrow until it clicks.

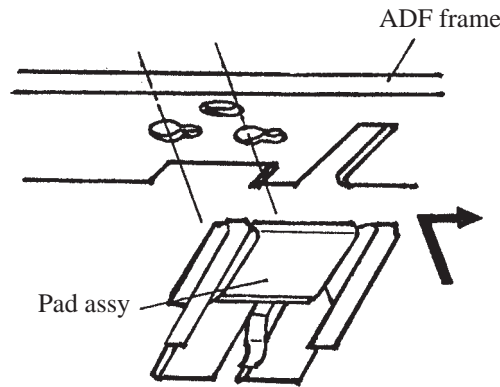

NOTICE : Set the paper select lever to "N", before removing pad ASY (See Section 4.3).

NOTICE : Pad can be replaced by aligning the holes of the pad with the pins of the pad holder.

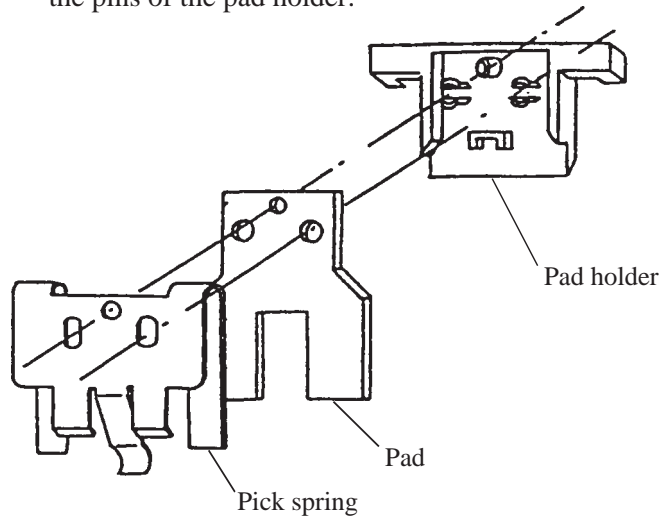

### 5.4.3 Replacing pick roller

Replace the pickroller as follows.

- (a) Pull the cap up to open the ADF unit.
- (b) Remove two thumb screws shown in Figure 5.4. And remove the Guide A.

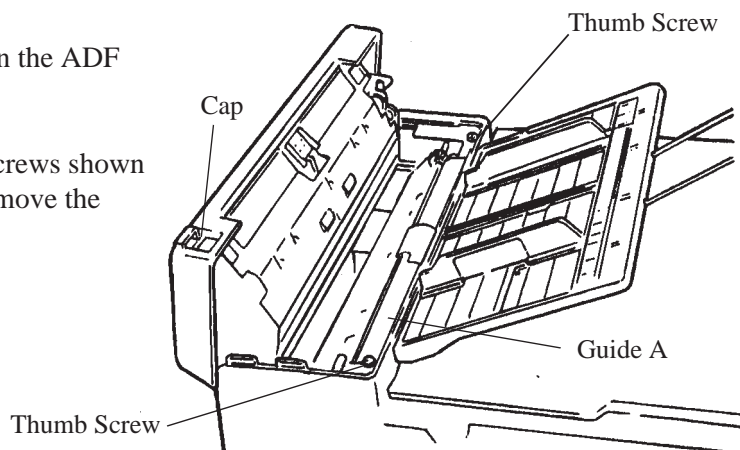
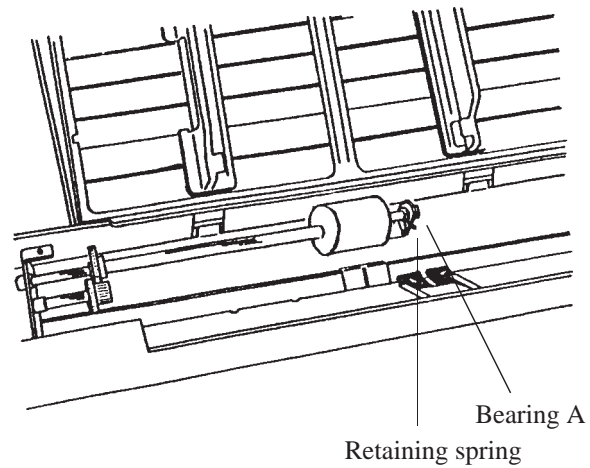

Figure 5.4 Pick Roller replacement

- (c) Pinch the retaining spring and slide it toward the roller. Free bearing A from the bracket by sliding it toward the roller.



**Figure 5.5 Move the Retaining spring**

- (d) Slide the pick roller shaft in the direction of arrow B and remove the shaft from bearing B. The roller shaft can then be lifted and removed as shown in Figure 5.7.

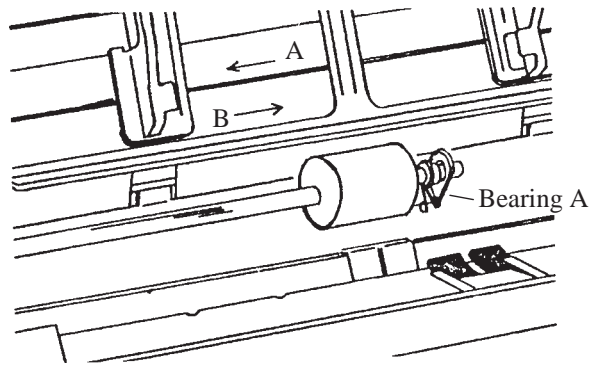

**Figure 5.6 Slide the Pick Roller**

- (e) Remove the bearing B.  
 (f) Mount the new pick roller in reverse order of removal.

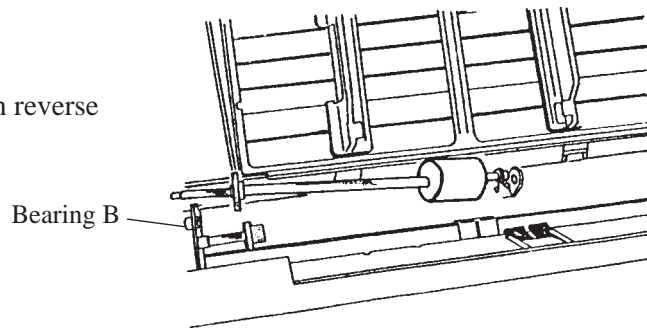

**Figure 5.7 Remove the Pick Roller**

**NOTICE:** When mounting the Guide A, note that the hooks of the retaining spring are not pressed by the Guide A. (See figure bellow)

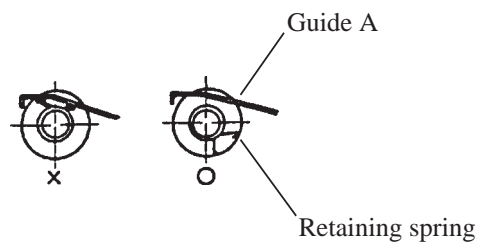

## CHAPTER 6 TROUBLESHOOTING

If a problem occurs, use Table 6.1 to resolve the problem.

**Table 6.1 Check items**

Problem	Possible cause	Response
No power	The power switch was not turned on.	Press the power switch.
	The power cable was not connected correctly.	Connect the power cable correctly.
	_____	Turn off the power once and make an attempt to turn on the power again. If the power is not turned on, contact your Fujitsu service representative.*
Read operation does not start.	The documents were not placed on the ADF correctly.	Insert the first a few pages into the slot.
	The ADF was not closed completely.	Make sure that the ADF is closed completely.
	The interface cables were not connected correctly.	Connect the interface cables correctly.
	Terminator was not connected. (M3096GX)	Connect the terminator.
Pictures and photographs are not read correctly.	Halftone processing was not selected.	Select a halftone mode from the host system.
	The document bed, document holding pad, or inside ADF is dirty.	Clean the dirty parts as explained in Section 5.3, "Cleaning."
Characters and lines are not read correctly.	Simple binarization was not done.	Select a binarization mode from the host computer.
	The document bed, document holding pad, or the inside of the ADF is dirty.	Clean the dirty parts as explained in Section 5.3, "Cleaning."
Image is distorted or unclear.	The document was moved during the read operation.	Keep the document cover closed during reading so that the document will not be moved.
	The document was not in contact with the glass.	Adjust the document so that it is in contact with the glass.

**Table 6.1 Check items (continued)**

Problem	Possible cause	Response
The check indicator is on.	The carrier fixing bracket was not removed.	Remove the carrier fixing bracket as explained in Section 3.2, "Removing the Carrier Fixing Bracket."
	_____	Turn the power off then on again. If the check indicator turns on again, contact the sales person in charge or a Fujitsu service representative.*
"Please clean Pick-roller" is displayed on the operator panel during the read operation in the ADF. Or check indicator blinks at four seconds period.	The pick roller is dirty.	When the power is turned off, the message is cleared. Even if the message is displayed, the read operation can be continued. Clean the pick roller after the read operation. (See Section 5.3.2.)
	The unallowable document was read in the automatic document feeder. (See Section 4.3.)	If a document not meeting the scanner specifications is read in the automatic document feeder, the document is not fed smoothly and an error message may be displayed. Read the document in the flat bed station.
Paper double feed	Pad is dirty.	Clean the Pad. (See Section 5.3.2)
	Pad is worn out.	Replace the pad. (See Section 5.4.2)
Miss pick	Pick roller is dirty.	Clean the Pick roller. (See Section 5.3.2.)
	Pick roller is worn out.	Replace the Pick roller. (See Section 5.4.3)
Paper jam	Some foreign particles are in ADF.	Clean the ADF (See Section 5.3.2) or remove any foreign particles.

\* Please check the test mode in appendix B, if possible, before calling the service representative and inform status of the indicators.

# APPENDIX A

## A.1 Installation Specifications

**Table A.1 Installation specifications**

Item		Specification		
External dimensions (mm)		Width	Depth	Height
		696	497	173
Weight (kg)		17.5		
Input power	Voltage	100 to 120 VAC, 200 to 240 VAC		
	Number of phases	Single-phase		
	Frequency	50/60 Hz		
Power		100 VA		
Temperature and humidity allowed ranges		Operation		Idle
		Temperature	5 to 35°C	-20 to 60°C
		Humidity	20 to 80%	8 to 95%

## A.2 External Dimensions

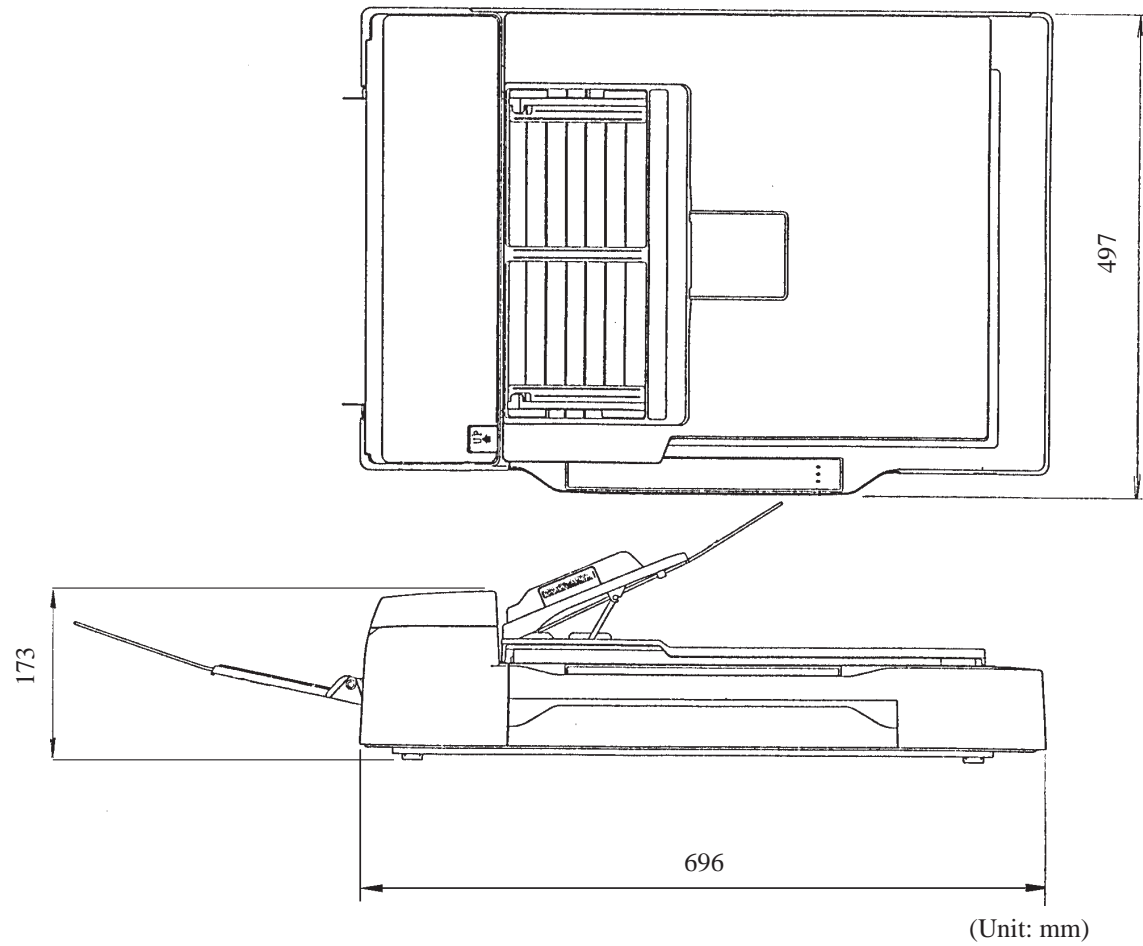

Figure A.1 External dimensions

# APPENDIX B

## B.1 Test mode for maintenance

**CAUTION:** Please follow the procedure here or the offset data may be changed incorrectly. If the scanner does not react as the procedure below, turn off the scanner and start from the beginning.

### (1) Activating a test mode

Open the ADF cover and set the sensors to the following state before turning on the image scanner. The image scanner can be placed in the maintenance mode by pulling out the empty sensor lever and setting the A4 size sensor lever to down position (do not change the setting of other paper size sensors) with the ADF cover fully opened (see Figure below). If the image scanner is placed in the maintenance mode, the POWER lamp blinks. If the POWER lamp does not blink, turn off the power and try again. Then close the ADF.

(Setting of the ADF sensors for maintenance mode)

- A4 size sensor: DOWN
- Empty sensor: UP

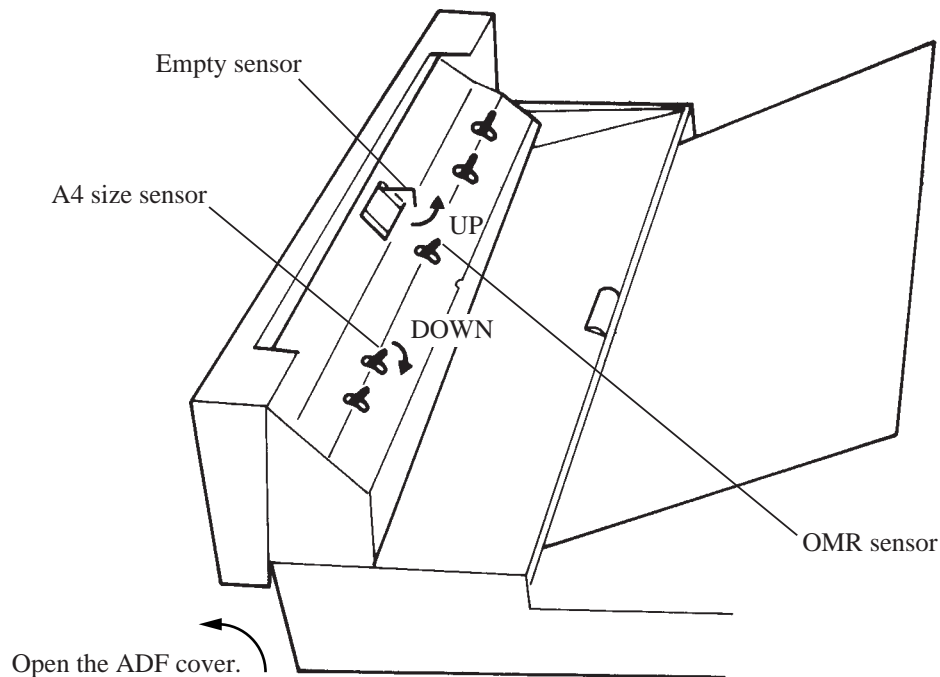



(2) Activating the continuous operation test

Open the ADF and close it again. If no document is loaded on the ADF within five seconds after closing the ADF cover, the image scanner runs in flatbed mode. If documents are loaded on the ADF within five seconds after closing the ADF cover, the image scanner continuously feeds the document from ADF. Once the image scanner start reading documents in the flatbed mode, it does not feed documents from ADF even if documents are loaded on the ADF.

(3) Ending the test in flatbed mode

To stop the carrier movement in flatbed mode, open the ADF cover. If the ADF cover is opened, the POWER lamp starts blinking immediately after the carrier returns to the home position.

(4) Ending the test in ADF mode

If the ADF document hopper is empty, feeding documents from the ADF ends. To restart feeding, open the ADF cover and close it again. Then load documents on the ADF document hopper within five seconds after closing the ADF cover.

(5) LED status on error

If an error occurs during the test, the LED indicates as shown in table B.1.

If paper is jammed in the ADF, remove the jam and close the ADF. The CHECK lamp stops blinking about three seconds after closing the ADF cover. To feed the document from ADF, open and close the ADF.

**Table B.1 LED at an error**

Errors/Alarm	POWER lamp	READ lamp	CHECK lamp
Paper jam	On	Off	Blink
Carrier drive alarm	Blink	Off	On
Optical system alarm	Blink	Off	Blink
Motor fuse failure	Blink	On	On
Lamp fuse failure	Blink	On	Blink

# APPENDIX C

## C.1 Option

Name	Specification	Scanner	feature
IPC-2	CA01952-0191	M3096EX M3096GX	Image processing <ul style="list-style-type: none"><li>• Automatic separation</li><li>• Image emphasis</li><li>• Outline extraction</li><li>• Mirror image</li><li>• Dynamic threshold</li><li>• Noise removing</li><li>• Smoothing</li></ul>
CMP-2	CA01952-0196	M3096GX	<ul style="list-style-type: none"><li>• 4Mbyte memory</li><li>• MH/MR/MMR compression</li></ul>

Contact your Fujitsu sales agent for more information

## C.2 IPC-2/CMP-2 option board installation

WARNING: Follow the outlined procedure to avoid danger from electrical components.

- (1) Verify that the scanner power is turned off.
- (2) Remove the AC cable from the rear of the scanner.
- (3) Remove the two screws securing the power supply and the interface PCA assembly. Pull out the assembly slightly using the tab in the direction shown by the arrow.

CAUTION: Do not pull on the flat cable too strongly or it may be damaged.

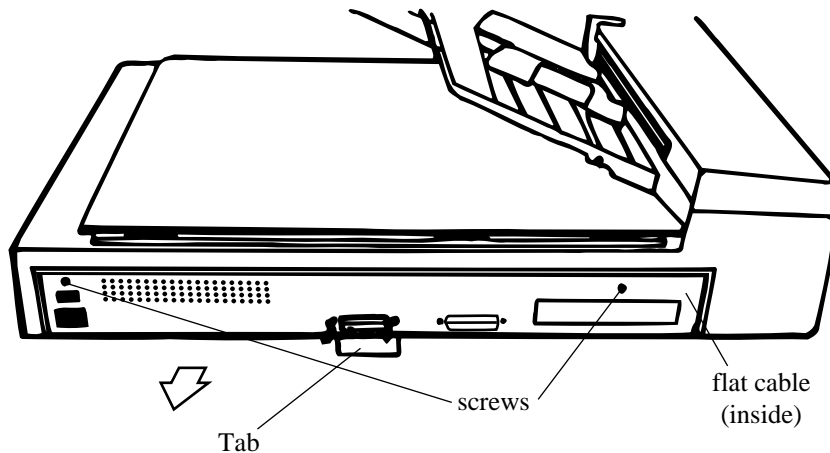

- (4) Remove the flat cable connector and detach the power supply and PCA assembly.

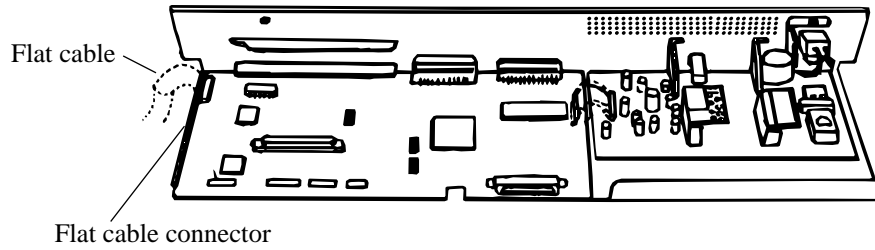

- (5) Connect the IPC-2 option board connector and tighten the screw.
- (6) Where a CMP-2 is installed, remove the screw from the memory board and detach the memory board. Connect the CMP-2 option board connector and tighten the screw.

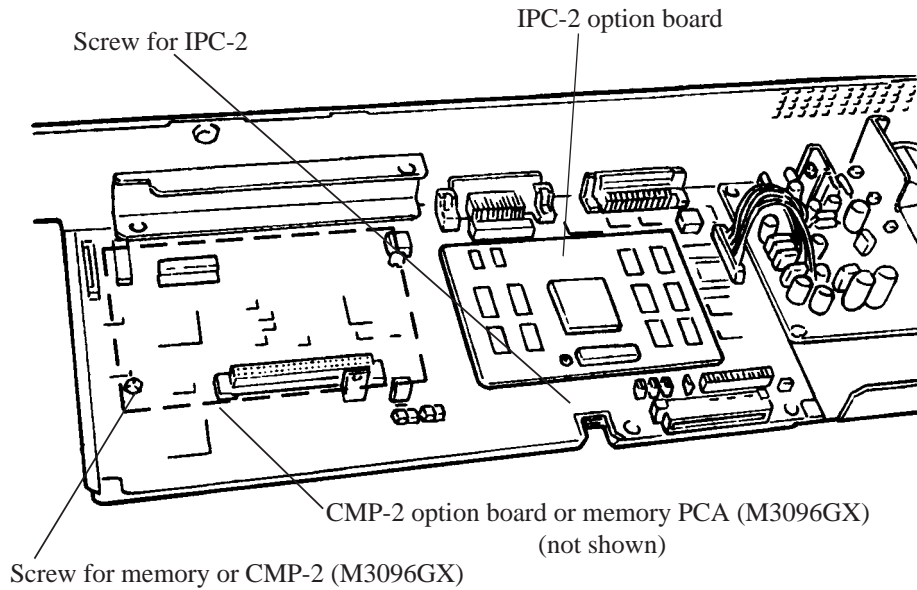

- (7) Attach the power supply and PCA assembly in the reverse order of removal.

Comments concerning this manual can be directed to one of the following addresses:

FUJITSU LIMITED  
International Operations  
Marunouchi 1-6-1, Chiyoda-ku, Tokyo 100,  
JAPAN  
TEL: (81-3) 3216-3211  
FAX: (81-3) 3213-7174  
TLX: J22833  
Cable: "FUJITSU LIMITED TOKYO"

FUJITSU COMPUTER PRODUCTS OF  
AMERICA, INC.  
2904 Orchard Parkway, San Jose.  
California 95134-2022, U.S.A.  
TEL: 1-408-432-6333  
FAX: 1-408-432-3908

FUJITSU CANADA, INC.  
2800 Matheson Blvd. East, Mississauga.  
Ontario 4X5, CANADA  
TEL: 1-905-602-5454  
FAX: 1-905-602-5457

FUJITSU DEUTSCHLAND GmbH.  
Frankfurter Ring 211,  
8000 Munchen 40, F.R, GERMANY  
TEL: 49-89-32378-0  
FAX: 49-89-32378-100

FUJITSU EUROPE LTD.  
2, Longwalk Road, Stockley Park, Uxbridge  
Middlesex, UB11 1AB, U.K  
TEL: 44-81-573-4444  
FAX: 44-81-573-2643  
TLX: 263871

FUJITSU NORDIC AB  
Kung Hans vag, S-191 76 Sollentuna, SWEDEN  
TEL: 46-8-626-6000  
FAX: 46-8-626-6711

FUJITSU ITALIA S.p.A.  
Via Melchiorre Gioia, No. 8-20124 Milano,  
ITALY  
TEL: 39-2-63651  
FAX: 39-2-6572257

FUJITSU FRANCE S.A.  
Batiment Aristote, 17 rue Olof palme  
94006 Creteil cedex, FRANCE  
TEL: 33-14-513-1616  
FAX: 33-14-399-0700

FUJITSU AUSTRALIA LIMITED  
475 Victoria Avenue Chatswood.  
N.S.W 2067, AUSTRALIA  
TEL: 61-2-410-4555  
FAX: 61-2-411-8603

FUJITSU HONG KONG Limited  
Room 2521, Sum Hung Kai Centre  
30 Harbour Road Wanchal, Hong Kong  
TEL: 852-827-5780  
FAX: 852-827-4724  
TLX: 62667

FUJITSU ESPANA, S.A  
Edificio torre Europa  
Paseo de la Castellana 95 Madrid 28046, SPAIN  
TEL: 34-1-581-8400  
FAX: 34-1-581-8125

