

**USER'S
GUIDE**

**Bradyprinter™ THT Model
200M and 260M
Thermal Transfer Printer**



W. H. BRADY CO.
AUTOMATIC IDENTIFICATION PRODUCTS

Bradyprinter™ THT Model 200M and 260M Thermal Transfer Printer

USER'S GUIDE

Customer part #31450L-12
Manufacturer part # 31450LB-12 Rev. 1



W. H. BRADY CO.
AUTOMATIC IDENTIFICATION PRODUCTS

Proprietary Statement

This manual contains proprietary information of Brady USA, Inc. It is intended solely for the information and use of parties operating and maintaining the equipment described herein. Such proprietary information may not be used, reproduced, or disclosed to any other parties for any other purpose without the expressed written permission of Brady USA, Inc.

Product Improvements

Continuous improvement of products is a policy of Brady USA, Inc. All specifications and signs are subject to change without notice.

FCC Compliance Statement

Note: This equipment has been tested and found to comply with the limits for a Class A digital Device, pursuant to Part 15 of the FCC Rules. These limits are designed to provide reasonable protection against harmful interference when the equipment is operated in a commercial environment. This equipment generates, uses and can radiate radio frequency energy and, if not installed and used in accordance with the instructions manual, may cause harmful interference to radio communications. Operation of this equipment in a residential area is likely to cause harmful interference in which case the user will be required to correct the interference at his own expense.

In order to insure compliance, this printer must be used with a Shielded Power Cord and Shielded Communication Cables.

“The user is cautioned that any changes or modifications not expressly approved by Brady USA, Inc. could void the user’s authority to operate the equipment.”

Canadian DOC Compliance Statement

This digital apparatus does not exceed the Class A limits for radio noise emissions from digital apparatus as set out in the radio interference regulations of the Canadian Department of Communications.

Liability Disclaimer

Brady USA, Inc. takes steps to assure that its published Engineering specifications and Manuals are correct; however, errors do occur. Brady USA, Inc. has been advised of the possibility of such damages. Because some states do not allow the exclusion or limitation of liability for consequential or incidental damages, the above limitation may not apply to you.

Copyrights

The copyrights in this manual and the label printer described therein are licensed to Brady USA, Inc. All rights are reserved. Unauthorized reproduction of this manual or the software in the label printer may result in imprisonment of up to one year and fines of up to \$10,000 (17 U.S.C.506). Copyright violators may be subject to civil liability.

ZPL II[®] and E³[®] are registered trademarks of Zebra Technologies Corporation
Centronics[®] is a registered trademark of Genicom Corporation
IBM[®] is a registered trademark of IBM Corporation

© Zebra Technologies Corporation, portions © Brady USA, Inc.

Bradyprinter™ THT Models 200M and 260M WARRANTY INFORMATION

1. Printer Warranty

BRADY printers, excluding thermal printheads which are warranted separately below, are warranted against defects in material or workmanship for six (6) months from the date of original shipment by BRADY USA, INC. This warranty does not cover normal wear and tear and shall be null and void if the equipment is modified, improperly installed or used, damaged by accident or neglect, or in the event any parts are improperly installed or replaced by the user.

Since printhead wear is part of normal operations, the original printhead and replacement printheads are covered by a limited warranty of six (6) months from the date of original shipment by BRADY USA, Inc. To qualify for this warranty, the printer must be returned to the factory or other authorized service center. Although the user is not required to purchase BRADY brand supplies (media and/or ribbons), to the extent it is determined that the use of other supplies (media and/or ribbons) shall have caused any defect in the thermal printhead for which a warranty claim is made, the user shall be responsible for BRADY USA, INC.'s customary charges for labor and materials to repair such defect. To the extent that it is determined that failure to follow the preventive maintenance schedule and procedures listed in the User Guide shall have caused any defect in the thermal printhead for which a warranty claim is made, this limited warranty shall be void.

BRADY USA, INC.'S SOLE OBLIGATION UNDER THIS WARRANTY SHALL BE TO FURNISH PARTS AND LABOR FOR THE REPAIR OR REPLACEMENT OF PRODUCTS FOUND TO BE DEFECTIVE IN MATERIAL OR WORKMANSHIP DURING THE WARRANTY PERIOD.

As a condition of this warranty, the user must: (a) obtain a BRADY Return Authorization for the printer, or subassembly(s); (b) ship the printer or subassembly(s), transportation prepaid to the authorized service location; and (c) include with the Product or subassembly(s) a written description of the claimed defect. Unless BRADY USA, INC. authorizes return of the entire Product, the user shall return only the subassembly(s). Products returned shall be packaged in the original packing and shipping container or comparable container. In the event equipment is not so packaged or if shipping damage is evident, it will not be accepted for service under warranty. Surface transportation charges for the return of the printer to the customer shall be paid by BRADY USA, INC. within the 48 contiguous states and the District of Columbia. Customer shall pay shipping costs, customs clearance, and other related charges outside the designated area. If BRADY USA, INC. determines that the Product returned to it for warranty service or replacement is not defective as herein defined, BUYER shall pay all costs of handling and transportation.

2. Supplies Warranty

BRADY supplies are warranted to be free from defects in materials or workmanship for a period of either the stated material shelf life or 6 months from date of shipment, whichever occurs first, provided that the BUYER has complied with BRADY USA, INC.'s guidelines on storage, handling, and usage of the labeling supplies in BRADY printers. BRADY USA, INC. does not warrant the performance of BRADY labeling supplies on non-BRADY printers.

Any supplies product shown to the satisfaction of BRADY USA, INC., within the time provided, to be so defective shall be replaced without charge, or BRADY USA, INC. may issue a credit in such an amount as it deems reasonable.

3. Warranty Exclusions and Conditions

The above warranties are in lieu of all other warranties, expressed or implied, oral or written, statutory or otherwise, including any *implied warranty of merchant-ability or fitness for a particular purpose*.

BRADY USA, INC. shall not be responsible for the specific application to which any Products are applied, including but not limited to compatibility with other equipment.

All statements, technical information and recommendations relating to BRADY Products are based upon tests believed to be reliable but do not constitute a guarantee or warranty.

BRADY USA, INC. SHALL NOT, UNDER ANY CIRCUMSTANCES WHATSOEVER, BE LIABLE TO BUYER OR ANY OTHER PARTY FOR LOST PROFITS, DIMINUTION OF GOOD WILL OR ANY OTHER SPECIAL OR CONSEQUENTIAL DAMAGES WHATSOEVER WITH RESPECT TO ANY CLAIM HEREUNDER. IN ADDITION, BRADY USA, INC.'S LIABILITY FOR WARRANTY CLAIMS SHALL NOT, IN ANY EVENT, EXCEED THE INVOICE PRICE OF THE PRODUCT CLAIMED DEFECTIVE, NOR SHALL BRADY USA, INC. BE LIABLE FOR DELAYS IN REPLACEMENT OR REPAIR OF PRODUCTS.

No salesperson, representative or agent of BRADY USA, INC. is authorized to make any guarantee, warranty, or representation in addition to the foregoing warranty.

NO WAIVER, ALTERATION, ADDITION, OR MODIFICATION OF THE FOREGOING WARRANTIES SHALL BE VALID UNLESS MADE IN WRITING AND SIGNED BY AN EXECUTIVE OFFICER OF BRADY USA, INC.

Table of Contents

Printer Warranty	i-i
Supplies Warranty	i-i
Warranty Exclusions and Conditions	i-ii

Introduction

Scope	1-1
Model Designation	1-1
System Overview	1-1
Communication Capabilities	1-2
Thermal Transfer Printer Internal Functions	1-2
Print Mechanism Capabilities	1-2
Media Transport Mechanism Capabilities	1-2
Additional System Requirements	1-3
Media and Ribbon Requirements	1-3
Warnings and Precautions	1-4
Installation	1-4
240 VAC Operation	1-4
Use of Shielded Cable	1-4
Ribbons and Printhead Wear	1-5
Repacking	1-5
Printer Specifications	1-6
Printing Considerations	1-6
Print Speeds	1-6
Media Handling	1-6
Media	1-7
Ribbon	1-8
Zebra Programming Language II (ZPL II [®])	1-8
Bar Codes	1-8
Standard Fonts	1-9
Standard Printer Font Examples	1-10
Physical	1-11
Electrical	1-11
Communications Interface	1-12
Environmental Ranges	1-12
Options	1-12
Accessories	1-12

Installation

Unpacking	2-1
Inspection	2-1
Reporting Damage	2-1

Storage and Reshipping	2-1
Power Connection	2-2
AC Voltage Selection Procedure	2-2
AC Power Fuse Replacement	2-3
100-120 VAC Operation	2-3
220-240 VAC Operation	2-3
Site Requirements	2-4
Ribbon Loading	2-4
Media Loading	2-7
Permasleeve Printing	2-7
Roll Media	2-7
Tear-Off Mode	2-9
Rewind Mode	2-9
Peel-Off Mode	2-9
Fanfold Media	2-10
Removing Used Ribbon	2-11
Initial Printer Power Up	2-11

Operation

Operating Your Brady M-Series Printer	3-1
Printer Operating Modes	3-1
Media Sensing Modes	3-1
Transmissive Sensing Mode	3-1
Black-Mark Sensing Mode	3-2
Media Transport Modes	3-2
Tear-Off Mode	3-2
Peel-Off Mode	3-2
Rewind Mode	3-3
Front Panel Keys	3-3
PAUSE Key	3-3
FEED Key	3-3
CANCEL Key	3-4
MODE Key	3-4
Front Panel Lights	3-5
Power On Self Test	3-6
Printer Self Tests	3-6
Introduction	3-6
CANCEL Key Self Test	3-7
PAUSE Key Self Test	3-8
FEED Key Test	3-9
FEED Key and PAUSE Key	3-10
MODE Key Test	3-10

PAUSE Key and CANCEL Key Test	3-10
FEED Key and CANCEL Key Test.	3-11
Extended Printer Diagnostics	3-11
Battery Replacement (<i>200M Only</i>)	3-11

Configuration and Calibration

Option Switches	4-1
Bank 1 (<i>For Serial-Interface Printers Only</i>)	4-2
Bank 2 (<i>260M Printers Only</i>)	4-3
Configuration Mode	4-4
Calibration.	4-4
Adjust the Print Darkness	4-6
Adjust the Media Rest Position	4-6
Adjust the Position of the Top of the Label.	4-6

Interconnections

System Components	5-1
System Considerations	5-1
Communications Code	5-1
Interfaces	5-1
Data Specifications	5-2
RS-232 Serial Data Port	5-2
Hardware Control Signal Descriptions	5-3
RS-232 Cabling Requirements	5-3
Interconnect to DTE Devices	5-4
Interconnect to DCE Devices	5-4
Parallel Cabling Requirements.	5-5
Parallel Interface	5-5
Signal Descriptions	5-6

Preventive Maintenance

Overview.	6-1
Cleaning	6-1
Exterior Surfaces	6-1
Interior.	6-1
Printhead and Platen Roller	6-2
Media, Ribbon, and Label Available Sensors	6-3
Lubrication	6-3

Adjustments

Toggle Positioning	7-1
Printhead Pressure Adjustment.	7-1
Black-Mark Media Sensor Position Adjustment	7-2
Transmissive Media Sensor Position Adjustment	7-2

Transmissive Media Sensor Positioning Using the Locator	7-3
Lower Transmissive Media Sensor Position Adjustment	7-6
Media and Ribbon Sensor Sensitivity Adjustment	7-7

Troubleshooting

Options

Peel-Off Option	9-1
Rewind Option	9-1
Optional Printer Fonts	9-1
220-240 VAC Factory Setup	9-2
Memory Options	9-2
512 KB DRAM Memory Expansion	9-2
256 KB SRAM Non-volatile Memory Expansion	9-2
6-Dot/mm Printhead (<i>200M Only</i>)	9-2

Appendix A - 240 VAC Power Cord

240 VAC Power Cord	A-1
--------------------------	-----

Appendix B - ASCII Code Chart

Appendix C - Adjusting Bar Code Darkness

Adjusting Darkness For "In-Spec" Bar Codes	C-1
--	-----

Appendix D - Optional Printer Fonts

Appendix E - Support Services

How to Reach Us	E-1
Technical Support	E-1
Technical Support Service via Telephone	E-2
Technical Support via E-mail or Fax	E-2
Product Service and Support Programs	E-4

Appendix F - Permasleeve Printing

Instructions for One-Sided Permasleeve Printing	F-1
Sensor Location	F-1
Toggle Setup	F-1
Printer Function Setup	F-1
Loading Permasleeve	F-2
Printer Calibration	F-3
Verifying Calibration	F-3
Leader Instructions	F-3
Printing	F-4
Save Settings	F-4
Instructions for Two-Sided Permasleeve Printing	F-4

Scope

This user's guide contains descriptive information and operational instructions for the Brady 200M and 260M thermal transfer demand printers.

This user's guide contains information on how to set up and operate the printer as well as adjustment and maintenance procedures that can be performed by the operator. Information covering the use and operation of Brady M-Series Printer options is also included.

Additional documentation for the Brady M-Series Printer is available.

- The *ZPL II[®] Programming Guide*.
- The two-volume Maintenance Manual:
 - Volume 1: General Maintenance* contains the information you will need to maintain your printer.
 - Volume 2: Circuit Descriptions and Electrical Schematics* contains the information you will need to repair the circuit boards at the component level.

Model Designation

Labels located inside the media compartment above the frame support at the rear of the M-Series Printer include both the serial number and model designation. If you need to contact our technical support staff for assistance, please have both the model designation and serial number available so that we may help you more efficiently.

System Overview

The M-Series Printer, when connected to an appropriate ASCII data source, functions as a complete label, ticket, and tag printing system. Customer-supplied asynchronous modems may be used to connect remote hosts to the M-Series Printer.

Connection of the M-Series Printer to data sources using data codes other than ASCII requires the use of an appropriate protocol converter. Connection to data sources using interfaces other than the type installed in the printer requires the use of an appropriate interface converter.

Communication Capabilities

The M-Series Printer comes with either an Electronics Industries Association (EIA) RS-232 serial data interface or a factory-installed parallel interface. In both cases, the required interface cable is not supplied with the printer.

Thermal Transfer Printer Internal Functions

Command/control data signals are received via the RS-232 port, parallel port, or DIP switches and are sent to the main logic board. The microprocessor continuously monitors these signals along with the inputs received from the control panel and various sensors. The microprocessor interprets this information and controls the M-Series Printer mechanics, printhead, communications, command interpretation, label formatting, media control, and mechanical drive.

Print Mechanism Capabilities

The print mechanism has been designed to print random information labels, tickets, and tags. It uses a square dot thermal printhead that heats a ribbon as it passes beneath the print elements, melting its ink onto the media (direct thermal uses heat-sensitive media instead of an inked ribbon). Constant print speeds may be selected via software control.

The standard printhead for the M-Series Printer has a print resolution of 8 dots/mm (203.2 dots/inch). An optional printhead is available for the 200M that has 6 dots/mm (152 dots/inch) resolution.

Media Transport Mechanism Capabilities

The media transport mechanism of the M-Series Printer has been designed to accommodate various types of media, including

die-cut labels, ticket and tag stock, continuous roll, and fanfold media.

Media may be rewound internally onto standard three-inch cores if the Rewind Spindle option is installed. With the Peel-off option, backing material may be rewound internally.

Ribbons for the M-Series Printer are supplied on cores in standard widths and lengths.

Additional System Requirements

In addition to the Brady M-Series Printer, you will need the following items to form a complete label preparation system:

- Label, ticket, or tag stock
- An intelligent device, such as a computer, for data entry or entry of ZPL II formats
- A data communication cable to connect the controlling device to the printer (remote installations may require additional cables and communication devices, such as modems and/or protocol converters)
- Thermal transfer ribbon (if using Thermal Transfer Mode)

Media and Ribbon Requirements

Print quality not only depends on the Brady M-Series Printer, but also on the print media. Factors such as reflectivity and contrast are important for bar code scanning applications. Factors such as paper abrasion and temperature requirements are important in maintaining the life of the printhead.

We **STRONGLY RECOMMEND** the use of Brady-brand media for continuous high quality printing. A wide range of paper, polypropylene, polyester, and vinyl stock has been specifically engineered to enhance the printing capabilities of the printer and to ensure against premature printhead wear.

Continuous roll form paper, fanfold media, or cardstock with optional perforations and registration holes may be used. The 260M can use “black-mark media”—media having a black mark printed on the liner side for use in positioning the labels. The life

of the printhead may be reduced by abrasion from exposed paper fibers when using perforated media.

Since print quality is affected by media and ribbon, printing speeds, and printer operating modes, it is very important to **run tests for your applications**. This is especially true if you're operating in "Peel-Off" mode, where these variables combine with label size, backing content, diecut depth, and even humidity to affect printer operation.

Warnings and Precautions

Installation

CAUTION: To ensure that the Brady M-Series Printer has proper cooling, do not place any padding or cushioning material on the back of, or underneath, the unit.

240 VAC Operation

CAUTION: Refer to Section 2 for instructions on configuring your printer for 240 VAC operation before connecting to a 240 VAC power source.

Use of Shielded Cable

CAUTION: Refer to the **Interconnections Section**.

Brady printers comply with FCC "Rules and Regulations", Part 15, Subpart J, for Class A Equipment, using fully shielded data cables. Use of unshielded cables may increase radiated emissions above the Class A limits and is not recommended.

Brady printers comply with international regulations governing radiated emissions when using fully shielded data cables. Use of unshielded cables may increase radiated emissions above the regulated limits.

Ribbons and Printhead Wear

CAUTION: Ribbons used in the Brady USA, Inc. Printer **MUST** be as wide as or wider than the media. Brady-brand ribbons provide an extremely smooth backing surface that protects the printhead from abrasion by the media. If the ribbon is narrower than the media, areas of the printhead will be unprotected and subject to premature wear.

Repacking

CAUTION: If shipment of your printer is necessary, carefully pack the printer in a suitable container to avoid damage during transit. Whenever possible, use the original container from the factory. If using a different container, a procedure similar to the original factory packaging should be followed.

Refer to Chapter 2 for further repacking instructions.

Printer Specifications

Printing Considerations

Specification		200M		260M
Resolution (thermal transfer or direct thermal)		203 dots per inch (8 dots per mm)	Optional 152 dots per inch (6 dots per mm)	203 dots per inch (8 dots per mm)
Dot size		0.00492" (0.125 mm)	0.00656" (0.167 mm)	0.00492" (0.125 mm)
Maximum print width		4.09" (104 mm)		6.30" (160 mm)
Maximum print length	Standard memory	15" (381 mm)	26" (660 mm)	9.5" (241 mm)
	With 512 KB additional memory	39" (991 mm)	39" (991 mm)	25" (635 mm)
Bar code modulus ("X") dimension		5 mil to 55 mil	6.6 mil to 72 mil	5 mil to 55 mil
Thin film printhead with Energy Control				

Print Speeds

Programmable constant printing speeds of 2" (51 mm), 3" (76 mm), 4" (104 mm), 5" (127 mm), and 6" (152 mm) per second.

Media Handling

- Tear-off mode: Produced in strips.
- Peel-off mode: Requires Peel-Off option or Media Rewind option. Labels are dispensed and peeled from the liner, and the liner is rewound internally.
- Rewind mode: Requires Media Rewind Option. A full roll of printed labels are rewound internally.

Media

Media Specifications			200M		260M	
Total media width	Maximum	4.5"	115 mm	7.2"	182.9 mm	
	Minimum	0.75"	19 mm	2.0"	50.8 mm	
Label length	Maximum	Refer to "Printing Considerations" on page 1-6.				
	Minimum	Tear-Off	0.5"	12.8 mm	0.63"	16.00 mm
		Peel-Off	0.5"	12.8 mm	0.75"	19.05 mm
		Rewind	0.5"	12.8 mm	0.75"	19.05 mm
Total thickness (includes liner)	Maximum (Printhead position may need to be adjusted above 0.01")	0.012"	0.304 mm	0.012"	0.304 mm	
	Minimum	0.0023"	0.058 mm	0.0023"	0.058 mm	
Core size		3.0"	75 mm	3.0"	75 mm	
Maximum roll diameter		8.0"	203 mm	8.0"	203 mm	
Interlabel gap (0.115"/3 mm preferred)		0.079" - 0.157"	2 - 4 mm	0.079" - 0.157"	2 - 4 mm	
Maximum internal fanfold media pack size (L x W x H)		8.0" x 4.5" x 6.2"	203 x 105 x 158 mm	8.00" x 7.2" x 6.2"	203 x 183 x 158 mm	
Additional Specifications for Black-Mark Media*						
Mark thickness (measuring parallel to label/tag edge)	Minimum	0.12"	3 mm	0.12"	3 mm	
	Maximum	0.43"	11 mm	0.43"	11 mm	
Mark width (measuring perpendicular to label/tag edge)	Minimum	0.43"	11 mm	0.43"	11 mm	
	Maximum	Full media width.		Full media width.		
Mark-to-mark leading edge registration tolerance		+/- 0.016"	+/- 0.4 mm	+/- 0.016"	+/- 0.4 mm	
Mark location		Mark is recommended to be located on the inside of the media (closest to the printer's mainframe when loaded in the printer). If mark is located elsewhere, test for your application.		Marks must be located on the inside of the media (closest to the printer's mainframe when loaded in the printer).		
Mark density		> 1.0 ODU (Optical Density Unit)				
Density of the back of the media on which the black mark is printed		0.5 ODU maximum				
* The 200M can be field-equipped with an optional reflective (black-mark) media sensor which replaces the factory-installed transmissive sensor. The black-mark media specifications shown for the 200M require that the optional reflective sensor kit be installed.						

Ribbon

Ribbon Width		200M		260M		
<i>Brady recommends using ribbon at least as wide as the media you are using to protect the printhead from wear.</i>		Maximum	4.33"	110 mm	6.85"	174 mm
		Minimum	0.95"	24 mm	2.0"	50.8 mm
Standard Lengths	2:1 media to ribbon roll ratio	984 ft	300 m	984 ft	300 m	
	3:1 media to ribbon roll ratio	1476 ft	450 m	1476 ft	450 m	
Roll size	Inner diameter of core	1.0"	25.6 mm	1.0"	25.6 mm	
	Outside diameter of full roll of ribbon	3.2"	81 mm	3.2"	81 mm	

Zebra Programming Language II (ZPL II®)

- Downloadable graphics with data compression
- Bit image data transfer and printing, including mixing of text and graphics
- Format inversion
- Mirror image printing
- Four-position field rotation (0°, 90°, 180°, 270°)
- Bitmap and scalable fonts
- Programmable quantity with print pause
- Communicates in printable ASCII characters
- Controlled by a mainframe, minicomputer, PC, or other data entry device
- Serialized fields
- In-Spec OCR-A and OCR-B
- UPC/EAN [nominal 100% magnification (6 dots/mm only)]

Bar Codes

- Code 11, Code 49, Code 93
- Code 39 (Supports ratios of 2:1, 3:1, 5:2, 7:3)
- Code 128 (Supports serialization in subsets B and C and UCC Case C Codes)
- CODABAR (Supports Ratios of 2:1, 3:1, and 5:2)
- Interleaved 2 of 5 (Supports Ratios of 2:1, 3:1, and 5:2; also supports Modulus 10 Check Digit)
- Industrial 2 of 5, Standard 2 of 5
- LOGMARS
- Plessey
- CODABLOCK
- MAXICODE
- UPC-A, UPC-E, UPC EXTENSIONS
- PDF 417
- POSTNET
- Check-digit calculation where applicable
- MSI
- EAN-8, EAN-13, EAN EXTENSIONS

Standard Fonts

The scalable smooth font (CG Triumvirate™ Bold Condensed) is expandable on a dot-by-dot basis, height- and width-independent, while maintaining smooth edges. Maximum size depends on available memory.

Fonts A, B, C, D, E, F, G, H, and GS are expandable up to 10 times, height- and width-independent; however, fonts E and H (OCR-A and OCR-B) are not considered in-spec when expanded.

IBM Code Page 850 international character sets are available in fonts A, B, C, D, E, F, G, and Ø through software control.

Note: See the **Options Section** for the availability of additional fonts.

Font Matrices for 8 dots/mm Printhead (200M and 260M)

Font	Matrix (in dots)			Type*	Character Size					
	Height	Width	Inter-character gap		Inches			Millimeters		
					Height	Width	Char./inch	Height	Width	Char./mm
A	9	5	1	U-L-D	0.044	0.029	33.90	1.13	0.75	1.33
B	11	7	2	U	0.054	0.044	22.60	1.38	1.13	0.89
C, D	18	10	2	U-L-D	0.088	0.059	16.95	2.25	1.50	0.67
E	28	15	5	OCR-B	0.138	0.098	10.17	3.50	2.50	0.40
F	26	13	3	U-L-D	0.128	0.079	12.71	3.25	2.00	0.50
G	60	40	8	U-L-D	0.295	0.236	4.24	7.50	6.00	0.17
H	21	13	6	OCR-A	0.103	0.093	10.71	2.63	2.38	0.42
GS	24	24	0	SYMBOL	0.118	0.118	8.48	3.00	3.00	0.33
Ø	Default: 15 X 12			U-L-D	Scalable					

* U = Uppercase, L = Lowercase, D = Descenders

Font Matrices for 6 dots/mm Printhead

Font	Matrix (in dots)			Type*	Character Size					
	Height	Width	Inter-character gap		Inches			Millimeters		
					Height	Width	Char./inch	Height	Width	Char./mm
A	9	5	1	U-L-D	0.059	0.039	25.40	1.50	1.00	1.00
B	11	7	2	U	0.072	0.059	16.93	1.83	1.50	0.67
C, D	18	10	2	U-L-D	0.118	0.079	12.70	3.00	2.00	0.50
E	21	10	3	OCR-B	0.138	0.085	11.72	3.50	2.17	0.46
F	26	13	3	U-L-D	0.171	0.105	9.53	4.33	2.67	0.38
G	60	40	8	U-L-D	0.394	0.315	3.18	10.00	8.00	0.13
H	17	11	4	OCR-A	0.112	0.098	10.16	2.83	2.50	0.40
GS	24	24	0	SYMBOL	0.157	0.157	6.35	4.00	4.00	0.25
Ø	Default: 15 X 12			U-L-D	Scalable					

* U = Uppercase, L = Lowercase, D = Descenders

Standard Printer Font Examples

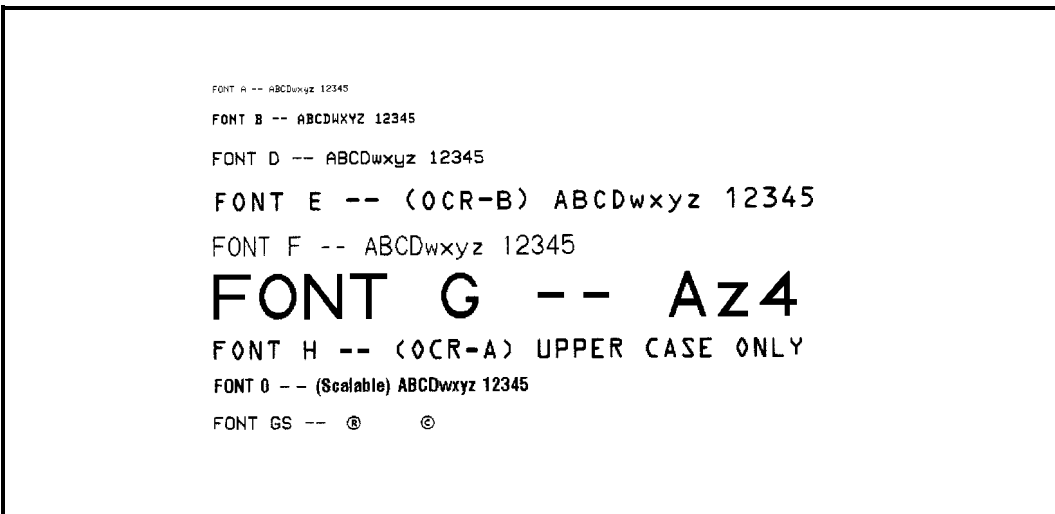

Figure 1.1 Default Fonts (8 Dots/mm Printhead)

FONT A - ABCDwxyz 12345

FONT B - ABCDWXYZ 12345

FONT D - AByz 123

FONT E - (OCR-B) ABCxyz 123

FONT F - ABCDwxyz 12345

FONT G - Az4

FONT H - (OCR-A) UPPER CASE

FONT O - (Scalable) ABCDwxyz 12345

FONT GS - ® ©

Figure 1.2 Default Fonts (6 Dots/mm Printhead)

Physical

Physical Characteristics	200M		260M	
	Height	15.4"	391 mm	15.4"
Width	10.5"	267 mm	13.1"	333 mm
Depth	18.9"	480 mm	18.9"	480 mm
Weight (option-dependent)	43 lbs.	19.5 kg	55 lbs.	24.9 kg

Electrical

100-120 VAC +10%/-15% or 220-240 VAC +10%/-15%; 48-62 Hz

5 Amps @ 115V, 3 Amps @ 230V

UL 1950 Listed-Certified to CAN/CSA-C22.2 No. 950- M89;
Classified to IEC 950; complies with FCC and Canadian DOC
class "A" rules

Carries the CE mark of compliance.

Communications Interface

- RS-232 at 110 to 19,200 baud (select from standard rates). Baud rate, data bits, parity, error detection protocol, and XON-XOFF or DTR/DSR handshaking are all switch-selectable.
- 200M: Centronics[®] parallel interface. 260M: Compatibility Mode Parallel Interface. Maximum cable length: 10 ft. (304.8 cm)

Environmental Ranges

Operating temperature		+40°F to +105°F	+ 4°C to +41°C
Storage temperature		-40°F to +158°F	-40°C to +70°C
Non-condensing relative humidity	Operating	20% to 85%	
	Storage	5% to 85%	

Options

6-dots/mm printhead (200M only)
 Media Rewind with rewind and peel-off capabilities
 Peel-Off capability only
 Additional 512 KB memory
 256 KB non-volatile memory (200M only)
 Scalable and bit-mapped smooth fonts

Accessories

A Printer Cleaning Kit (PCK-2) is available from Brady USA, Inc.

Unpacking

When unpacking the Brady M-Series Printer, make sure you save all packing materials. Once the printer is out of the box, raise the printer's Media Access Door and remove the power cord.

Inspection

Inspect the printer for possible damage incurred during shipment.

- Check all exterior surfaces for damage.
- Raise the Media Access Door and inspect compartment for damage to components.

Reporting Damage

If you discover shipping damage upon inspection:

1. Immediately notify the shipping company of the damage.
2. Retain all packaging material for shipping company inspection.
3. File a damage report with the shipping company and notify your local distributor and Brady USA, Inc. of the damage. Brady USA, Inc. is not responsible for any damage incurred during shipment of the equipment and will not repair this damage under warranty. Immediate notification of damage to the shipping company or its insuring agency will generally result in ensuring any damage claim validity and ultimate monetary compensation.

Storage and Reshipping

If you are not placing the printer into operation immediately, repackage it using the original packing materials. The M-Series Printer may be stored under the following conditions.

- Temperature: -40° to +158° F (-40° to +70° C)
- Relative humidity: 5% to 85% non-condensing

Should it become necessary to ship your printer, **remove any ribbon and paper roll** from the supply spools, otherwise damage to the printer could result. Carefully pack the printer in a suitable container to avoid damage during transit. Whenever possible, use the original container and packaging material from the factory. If you use a different container, a procedure similar to the original factory packaging should be followed.

CAUTION: Do not package the printer in a rigid container without utilizing shock mounts or shock-absorbing packing material. A rigid container will allow shock on the outside to be transmitted undamped to the unit, which may cause damage.

Power Connection

AC Voltage Selection Procedure

The M-Series Printer's AC voltage may be set for either 100-120 VAC or 220-240 VAC operation. To match the printer's power entry selection to the available power source, refer to Figure 2.1 and follow the procedure outlined below:

1. Locate the AC power area at the rear of the printer.
2. Using a small flatblade screwdriver or similar tool, move the Voltage Selection switch to the 100-120 V or 220-240 V position as required. (The initial position of the switch depends on how the printer was ordered.) Make sure that the appropriate fuse is in place. See Fig. 2.1.

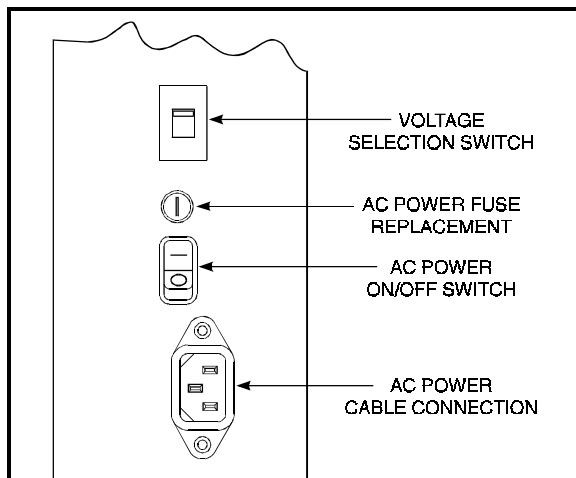

Figure 2.1 AC Power Area

AC Power Fuse Replacement

A user-replaceable AC Power Fuse is located just above the Power ON/OFF Switch. (See Figure 2.1.) For a 100-120 VAC installation, the replacement fuse is a 3AG Fast Blow style rated at 5 Amp/250VAC. For a 220-240 VAC installation, the fuse is the same style but rated at 3 Amp/250VAC. ***Make sure the fuse you use is correct for the voltage source.***

Before replacing the fuse, turn the AC Power Switch OFF and unplug the AC Power Cable.

To replace the fuse, insert the tip of a flat blade screwdriver into the slot in the end of the Fuse Holder End Cap. Press in slightly on the End Cap and turn the screwdriver slightly counter-clockwise. This will disengage the End Cap from the Fuse Holder and allow you to remove the fuse. To install a new fuse, reverse the procedure.

100-120 VAC Operation

1. Confirm that the voltage selector switch is set to 120 V.
2. Attach the supplied power cord to the AC power receptacle located on the rear of the printer.
3. Connect the opposite end of the power cord to a properly grounded source of 100-120 VAC (50 or 60 Hz) power rated for at least 5 Amps.

220-240 VAC Operation

1. Confirm that the voltage selector switch is set to 240 V.
2. Depending on how the printer was ordered, a power cord may or may not be provided for 220-240 VAC operation. If not provided, obtain a cord set with the proper AC Power plug. The cord may then be connected to the standard (international) IEC-type 3-prong AC connector provided on the M-Series Printer. Refer to **Appendix A** for more information.

Site Requirements

CAUTION: To ensure that the M-Series Printer has proper ventilation and cooling, do not place any padding or cushioning material on the back of or underneath the unit because this will restrict the air flow.

The M-Series Printer may be installed on any solid, level surface of sufficient size and strength to accommodate the unit. The area in which the printer will operate must meet the environmental conditions specified.

Since the Brady M-Series Printer was designed and is fabricated as an industrial-type unit, it will function satisfactorily in areas such as a warehouse or factory floor that conform to the specified environmental and electrical conditions.

Ribbon Loading

Refer to Figure 2.3 throughout this procedure.

Note: When placing the ribbon roll on the Ribbon Supply Spindle, make sure that the core is pushed up against the stop on the ribbon supply spindle and that the ribbon is aligned squarely with its core. If this is not done, the ribbon may not cover the inside edge of the printhead, exposing print elements to potentially damaging contact with the media.

Note: **Do not** load ribbon if the printer is to be used in the Direct Thermal Mode.

CAUTION: **Do not** use ribbon that is narrower than the media. If the printhead is not protected by the smooth backing of the ribbon, excessive abrasion may cause premature printhead failure.

1. Align the segments of the Ribbon Supply Spindle. See Figure 2.2. The Ribbon Supply Spindle is actually made up of either two or three segments that rotate independently. Each segment has a Spring Plate on it. It is important that these Spring Plates be in alignment prior to installing the ribbon roll on the spindle.
2. Place the Ribbon Roll on the Ribbon Supply Spindle.
3. Open the printhead by moving the handle to the OPEN position.
4. **Important.....** To make ribbon loading and unloading easier, make a leader for your ribbon roll if it doesn't already have one:
Tear off a strip of media (labels and backing) about 6 to 12 inches long from the roll. Peel off a label from this strip. Remove the remaining labels. Apply half of this label to the end of the strip and the other half to the end of the ribbon. This acts as a ribbon leader.
5. Thread the leader and attached ribbon as shown in the illustration. Be careful not to crease or wrinkle the ribbon.
6. Remove the Hook from the Ribbon Take-Up Spindle.
7. Place the leader under the long leg of the Hook and wind several turns.
8. Close the printhead by moving the lever to the CLOSED position.

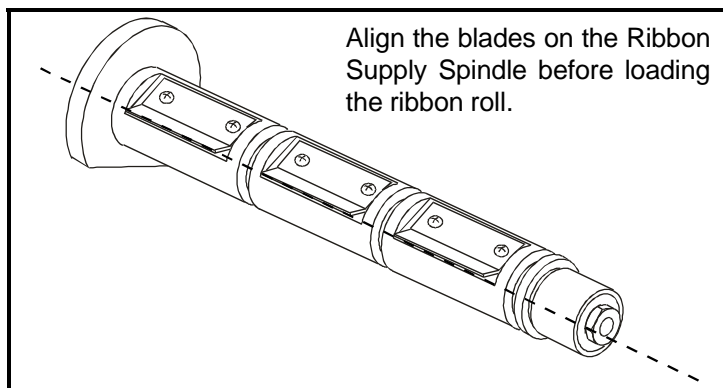

Figure 2.2 Ribbon Supply Spindle Alignment

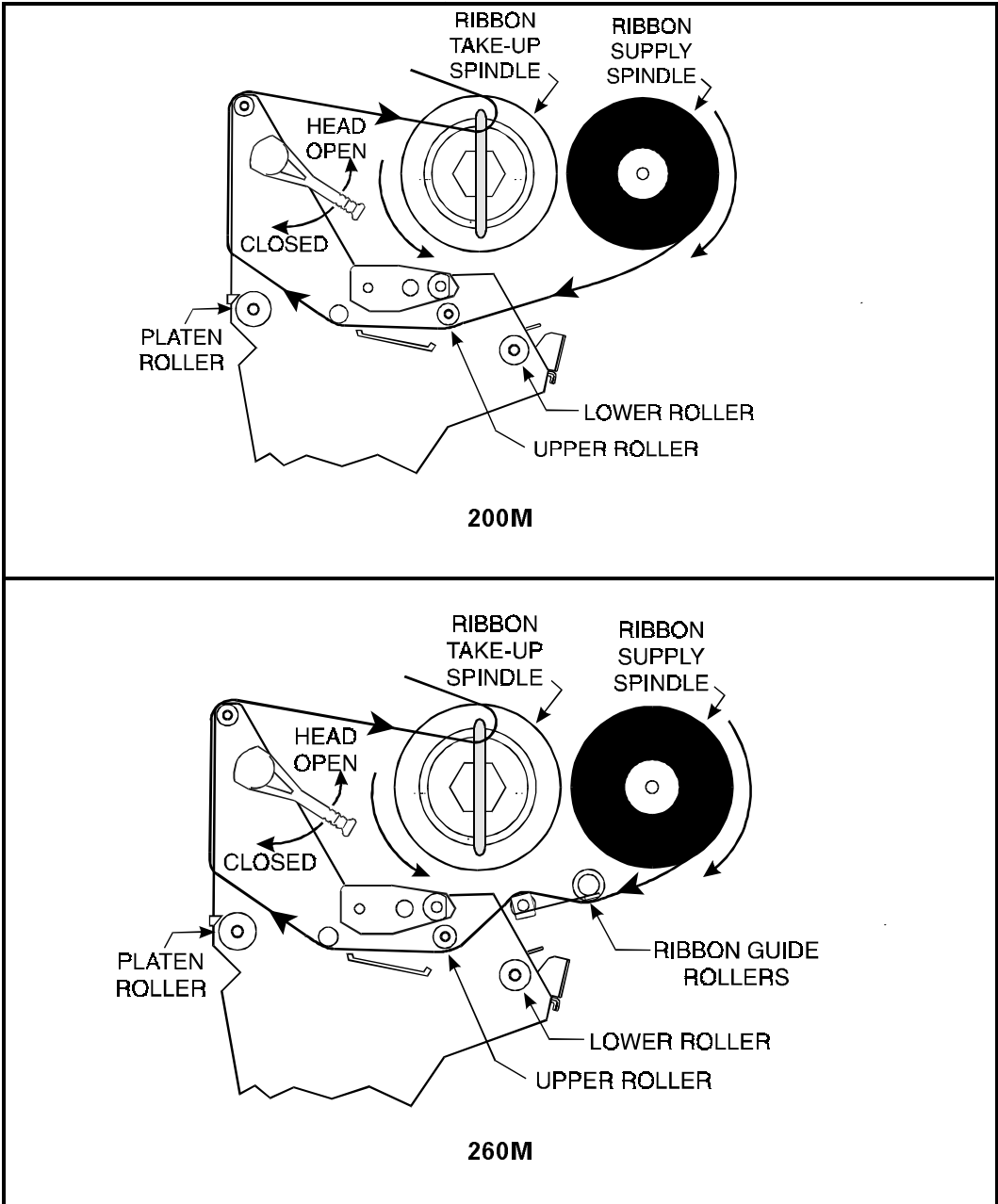

Figure 2.3 Ribbon Loading Diagram

Media Loading

To load media, move the Printhead Locking Lever to the OPEN position. Refer to Figures 2.4, 2.5, and 2.6. When the media is loaded, close the printhead by moving the lever on the upper printhead mechanism to the CLOSED position.

Note: The first time you load media and whenever you subsequently change the media type you must re-calibrate the printer. See the Configuration and Calibration Section.

Permasleeve Printing

For information about Permasleeve Printing, refer to Appendix F.

Roll Media

Roll media may contain labels of a fixed length with gaps in-between or it may be formed as one continuous length with no gaps (see *Continuous Media*.) Both types of roll media mount inside the printer in the same manner. To load roll media, refer to Figure 2.4 and/or 2.5 and do the following.

1. Move the Media Guide and Media Supply Guide as far away from the printer frame as possible.
2. Place the media roll on the Media Supply Hanger.
3. Push the Media Supply Guide inward until it is just touching the outer side of the Media Supply Roll, then lock the guide in place with its locking screw. (The Guide must not cause pressure or excessive drag on the Media Supply Roll.)
4. Thread the media through the printhead as shown in the illustrations.
5. Adjust the Media Guide and Media Supply Guide until they just touch the outer edge of the media without causing it to buckle.
6. Close the printhead by moving the lever located on the upper printhead assembly to the CLOSED position.

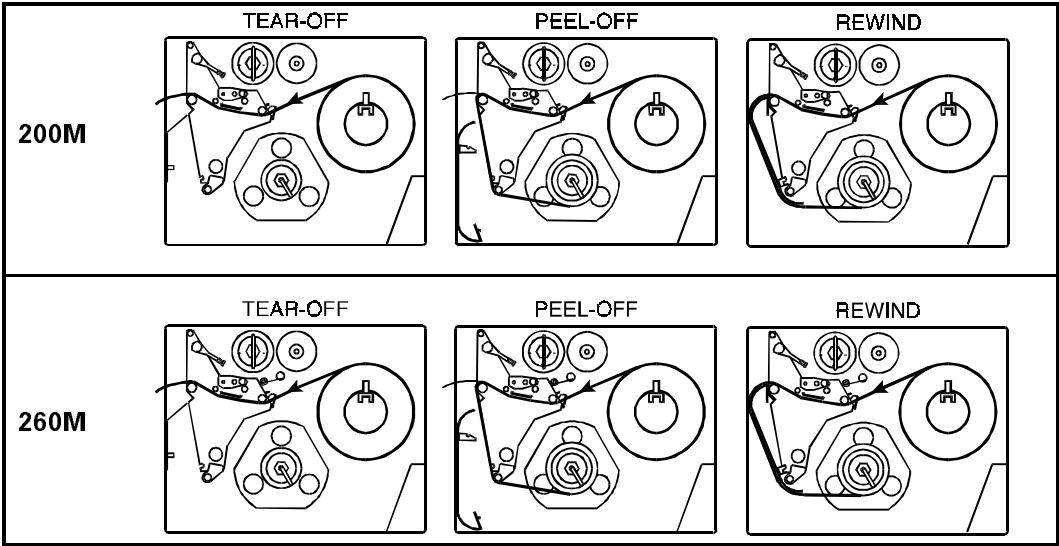

Figure 2.4 Roll Media Loading Diagrams

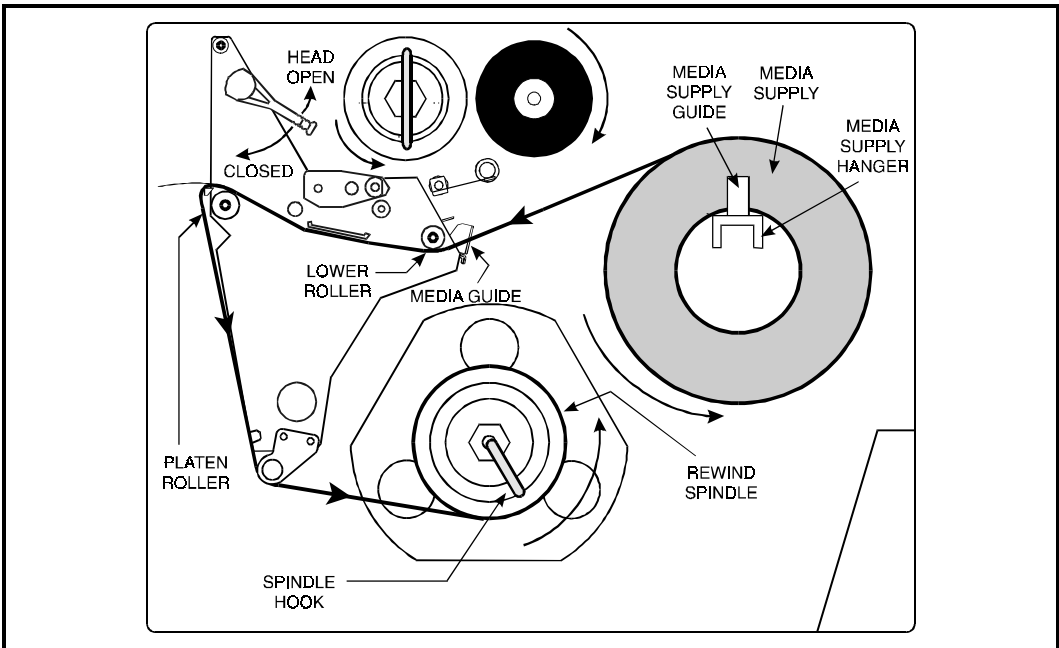

Figure 2.5 Roll Media Loading Diagram (with Peel-Off)

Tear-Off Mode

Follow the instructions described in Roll Media.

Rewind Mode

The Rewind Option must be installed in the printer. To initially configure the printer for this mode, follow these steps:

1. Remove the Media Rewind Plate from its storage location in front of the printhead inside the media compartment.
2. Invert the Rewind Plate so that the lip on the attached Hook Plate points down.
3. Insert the Hook Plate lip a short distance (1/2") into the lower opening in the Side Plate.
4. Align the upper end of the Rewind Plate with the corresponding opening in the Side Plate and slide the Rewind Plate in so that it stops against the Main Frame.
5. Remove the Hook from the Take-Up Spindle Shaft.
6. Route the media as shown in Figures 2.4 and 2.5, wind it 1-2 times around a 3" core.

Peel-Off Mode

After loading the media, follow these steps:

1. Remove the Rewind Plate if one is present and store it on the two mounting screws on the inside of the front panel. Align the notch or web in the media so that the Take Label Sensor can sense a peeled label.
2. Load media as shown in Figures 2.4 and 2.5.
3. Remove the Hook from the Take-Up Spindle Shaft.
4. Remove several labels from the media backing and then wind the backing 1-2 times around the Media Take-Up Spindle and reinstall the Hook.

Fanfold Media

To load fanfold media, place the fanfold media in the bottom or to the rear of the media compartment and thread it through the printhead as shown in Figure 2.6. Adjust the media guide using the thumb screw to keep the media from drifting left or right.

Fanfold media from outside the printer feeds through one of the two access slots, one at the bottom of the printer and one at the rear.

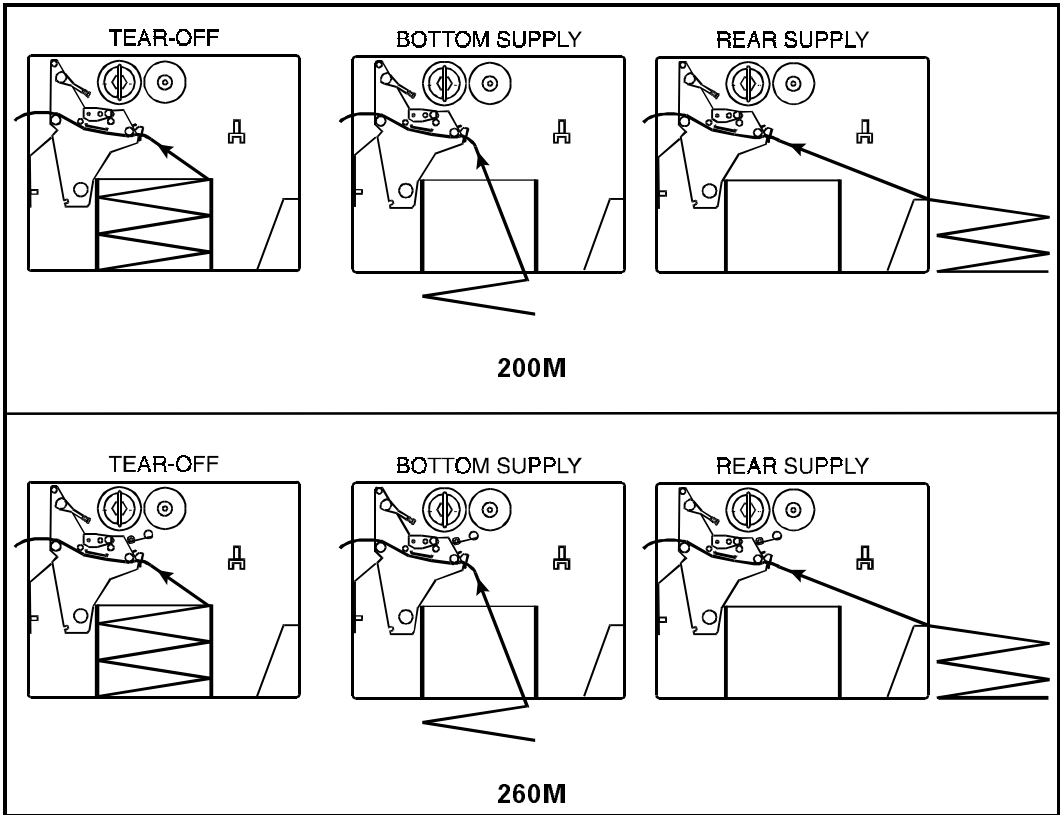

Figure 2.6 Fanfold Media Loading Diagrams

Removing Used Ribbon

To remove used ribbon, refer to Figure 2.7 and follow the steps below.

1. Pull the hook out slightly, then rotate the hook back-and-forth several times as shown and remove it from the spindle.
2. Grasp the used ribbon and remove it from the Ribbon Take-Up Spindle.
3. Remove the empty core from the Ribbon Supply Spindle.
4. Follow the Ribbon Loading procedure on page 2-4 to load the new ribbon.

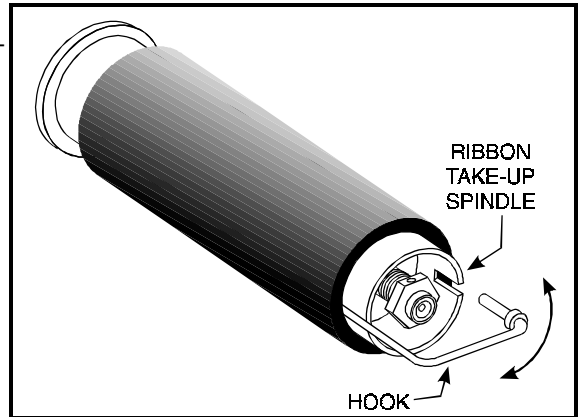

Figure 2.7 Removing Used Ribbon

Initial Printer Power Up

After you finish loading the ribbon and media, continue reading through Sections 3 and 4. Perform the following initial printer power-up steps as you come to them:

1. Power ON Self Test (POST)
2. Calibration

Subsequent power-ups will not necessarily require step 2 to be performed. See Sections 3 and 4 for further information.



Operating Your Brady M-Series Printer

Now that your printer is ready for operation, how does it work? The Brady M-Series Printer is designed to receive instructions from a host computer, such as an IBM-compatible PC. To create a label, you will either need to use label design software or write a format in ZPL II[®], which is a programming language for creating label formats. If you are using label design software, refer to the instructions provided with your software package to determine how to proceed.

If you are using, or plan to use, ZPL II, make sure you have a copy of the *ZPL II Programming Guide*. This free guide was available at the time you ordered your printer, but if you do not have a copy then submit the mail- or fax-in card in the front of this book to get a copy.

Printer Operating Modes

The M-Series Printer can be configured for several different modes of operation by sending the proper commands from the host computer. For 260M printers, operating modes may also be configured via a bank of DIP switches at the rear of the printer. (See Chapter 4 for more information about DIP switches.)

Media Sensing Modes

There are two basic modes by which the printer can sense the position of the media: Transmissive Sensing Mode and Black-Mark Sensing Mode. The 260M comes standard with both Transmissive Sensing Mode and Black-Mark Sensing Mode capabilities. The 200M comes standard with Transmissive Sensing Mode capability, but you may field-retrofit it for Black-Mark Sensing by replacing the Transmissive Sensor with a Black Mark Sensor.

Transmissive Sensing Mode

In Transmissive Sensing Mode, a sensor detects a light shining through a web, notch, or hole in non-continuous media. In this way, the printer determines the position of the label/tag.

Black-Mark Sensing Mode

In Black-Mark Sensing Mode, you use continuous media (no notch or gap) having black marks printed on the back of the label liner for each label. To determine the label length and top of label, the printer's Black Mark Sensor detects the black mark similar to the way in which the Transmissive Sensor detects the notch or gap in the media.

*Media Transport Modes***Tear-Off Mode**

When the media is in the rest (idle) position, the webbing between labels is over the Tear-Off/Peel-Off Bar. To print a label, the printer first backfeeds the media until the start of the label is directly under the printhead and then prints the entire label.

After a label is printed, the media feeds forward until the end of the label is past the Tear-Off/Peel-Off Bar. This label position is determined by commands sent to the printer from the host computer.

When a quantity of labels is required, a format for printing a batch of labels can be sent to the printer. Once a label is printed, the media will feed forward to the start of the next label and printing will continue. In this way, the printer will print the batch and stop when it reaches the quantity required.

When a quantity of individual labels is required, the format for printing a batch of labels can still be sent to the printer. The operator can use the PAUSE Key to cycle the printing one label at a time. The operator can then tear off each label before printing the next one.

Peel-Off Mode

When the media is in the rest (idle) position, the start of the label to be printed is slightly in front of the printhead. To print a label, the printer first backfeeds the media until the start of the label is directly under the printhead and then prints the entire label.

In this mode, once the label is printed, the media passes over the Tear-Off/Peel-Off Bar at an extremely sharp angle. The backing material is peeled away from the label and winds around the Peel-Off Spindle or the Media Rewind Spindle. The media feeds forward until most of the label hangs loose from the backing. The

label is held in this position by that portion of the backing that has not crossed the Tear-Off/Peel-Off Bar.

The Label Available Sensor is located on the printer in a position where it is activated by the label. When the operator removes the label, the printer backfeeds the media either to the rest (idle) position or to the printing position and prints the next label. When it is necessary to remove the media backing from the Take-Up Spindle, you do not need to turn the printer OFF.

Rewind Mode

Some applications call for the media to be rewound onto a core as the labels are printed.

When the media is in the rest (idle) position, the start of the next label is directly under the printhead. After the label is printed, the media feeds forward until the start of the next label is under the printhead. The media never backfeeds in this mode.

When the printer completes a batch of labels, printing will stop.

Front Panel Keys

PAUSE Key

The PAUSE key stops and restarts the printing process.

If the printer is idle (not printing) when the PAUSE key is pressed, no printing can occur. If the PAUSE key is pressed while printing is in progress, the printing stops once the current label is complete.

Pressing the PAUSE key a second time resumes the printing process.

FEED Key

The FEED key forces the printer to feed one blank label. If the printer is idle (not printing), or if the PAUSE function is active when the FEED key is pressed, one blank label feeds from the printer immediately. If the printer is printing, then one blank label feeds out after completion of the current batch of labels.

After one blank label feeds out, pressing FEED again provides another blank label.

CANCEL Key

The CANCEL key is only recognized in PAUSE mode.

Press CANCEL to cancel the current label format. If no format is printing, then the next one to be printed will be canceled. If no formats are in memory, the CANCEL key is ignored.

If the CANCEL key is pressed for an extended period of time (3 seconds), the printer cancels all formats in memory and the DATA light turns OFF.

MODE Key

The MODE key puts the printer in Configuration Mode. In this mode, you can adjust the Print Darkness, Media Tear-off Position, and Label Top Position, or perform a Calibration. See Section 4.

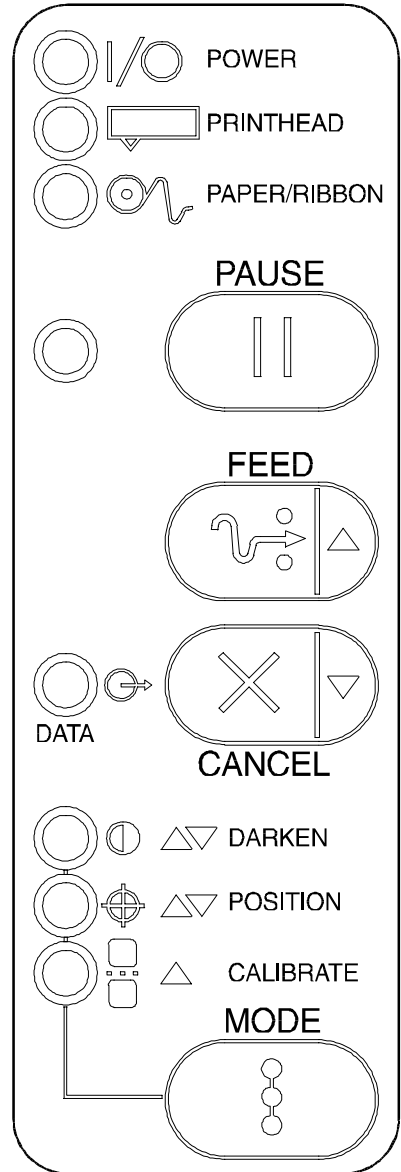

Figure 3.1 Printer Front Panel

Front Panel Lights

Refer to Figure 3.1 for the location of the lights.

Note: If an operating condition which causes a light to be ON constantly and one which causes the same light to Flash occur simultaneously, the light Flashes.

Light (LED) Name	Status	Indication
POWER	ON	Printer is ON.
PRINthead	OFF	Normal operation.
	ON	Head Over Temperature condition. Printing stops until the printhead cools down. Printing resumes automatically.
		Printhead Under Temperature condition. Printing continues.
	Flashing	Power Supply Over Temperature condition. Printing stops until the power supply cools down. Printing resumes automatically. Printhead Open.
PAPER/ RIBBON	OFF	Media and ribbon (if used) are properly loaded.
	ON	Paper out.
	Flashing	1. In Thermal Transfer Mode: Ribbon is out. 2. In Direct Thermal Mode: Ribbon is in the printer.
PAUSE	OFF	Normal operation.
	ON	Printer has stopped all printing operations.
DATA	OFF	Normal operation, no data being received.
	ON	Labels are printing.
	Single flash	The CANCEL key was pressed and a format was successfully deleted from the print queue.
	Flashing	Receiving data from host computer.
	Slow flashing	Printer sent a “stop transmitting” command to the host computer.
DARKEN	ON	Printer is in the Configuration Mode. See Section 4, Configuration and Calibration, for more information.
POSITION	ON	
CALIBRATE	ON	

Power On Self Test

A Power ON Self Test (POST) is performed each time the printer is turned ON. This test checks for proper initialization of various electronic circuits and establishes starting parameters as those stored in the printer's memory. During this test sequence, the front panel lights will turn ON and OFF to ensure proper operation. At the end of this self test, only the POWER light will remain lit. If other lights are also lit, refer to the Troubleshooting Section.

Printer Self Tests

Introduction

These self tests produce sample labels and provide specific information that helps determine the operating conditions for the printer.

Each self test is enabled by holding in a specific Front Panel key or combination of keys while turning the Power Switch ON. Keep the key depressed until the Front Panel Lights turn ON.

When the Power On Self Test is completed, the selected self test automatically starts.

Notes: When performing self tests, all data interface cables connected to the rear of the printer must be removed.

When canceling a self test before its actual completion, always turn the printer Power OFF and then back ON to reset the printer.

When performing these self tests in the Peel-Off Mode, the operator must remove the labels as they become available.

Unless specifically stated, all tests print in Tear-Off mode in Tear-Off printers and in Peel-Off Mode for Peel and Rewind printers.

If your media is not wide enough, the test labels will only print out to the edge of the label. If your media is too short, the test label will continue printing on the next label.

CANCEL Key Self Test

This self test prints a single label which contains a listing of the printer's current configuration parameters stored in Configuration (EEPROM) Memory. Press the CANCEL key while turning the AC Power Switch ON. See Figure 3.2.

The configuration may be changed either temporarily (for specific label formats or ribbon and label stock), or permanently (by saving the new parameters in EEPROM Memory.) Saving new parameters

occurs whenever a Printer Calibration procedure is performed. Refer to the procedure in Section 4, Configuration and Calibration.

Printer Configuration	
13.....	Darkness
+16.....	Tear Off Adjust
060.....	Web Sensor
088.....	Media Sensor
028.....	Ribbon Sensor
1238.....	Label length
39.00IN 989MM.....	Max Label Length
4.09IN 104MM.....	Print Width
Tear Off.....	Print Mode
Non-Continuous.....	Media Type
Thermal Transfer....	Print Method
Main Serial RS232...	Host Port
None.....	Network Port
19200.....	Baud
8.....	Data Bits
None.....	Parity
1.....	Stop Bits
XON/XOFF.....	Handshake
None.....	Protocol
2CH.....	Delimiter
5EH.....	Format Prefix
7EH.....	Control Prefix
000.....	Network ID
DPCS.....	Modes Enabled
.....	Modes Disabled
832 8/mm Full.....	Resolution
Default.....	Backfeed
-40.....	Label Top
+0000.....	Left Position
.....	Socket 1 ID
.....	Socket 2 ID
V14.4.3.....	Firmware
Customized.....	Configuration
1024k.....	Memory
Installed.....	B: Memory
Feed.....	Media Power Up
Feed.....	Media Head Close

Software in this printer is Copyrighted

Figure 3.2 Cancel Key Test Sample Printout

PAUSE Key Self Test

This self test is actually comprised of four individual test features.

1. The initial self test prints 15 labels at speed "A" (2" per second) then automatically PAUSES the printer. Each time the PAUSE key is pressed, an additional 15 labels print out.
2. While the printer is PAUSED, pressing the CANCEL key once alters the self test. Now each time the PAUSE key is pressed the printer prints 15 labels at speed "D" (6" per second).
3. While the printer is PAUSED, pressing the CANCEL key a second time alters the self test again. Now, each time the PAUSE key is pressed the printer prints 50 labels at speed "A".
4. While the printer is PAUSED, pressing the CANCEL key once alters the self test a third time. Now, each time the PAUSE key is pressed the printer prints 50 labels at speed "D".

Note: On printers with either the rewind or peel option installed, the Peel Mode is activated during the first half (steps 1–4) of the PAUSE Key Self Test. On printers with a rewind option, the rewind plate must be removed for proper function of the peel sensors during the test. The first label to print will say, "PEEL OPTION INSTALLED". Each label must be manually removed from the sensor path before the next label will print. Steps 1–4 will then be repeated in Rewind Mode.

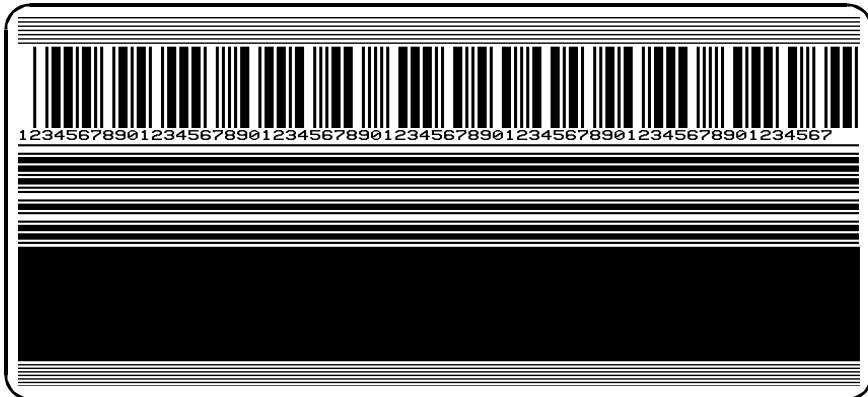

Figure 3.3 Pause Key Test Sample Printout

This self test can be used to provide the test printouts required when making adjustments to the printer's mechanical assemblies. See the sample printout in Figure 3.3.

FEED Key Test

The CANCEL Key Self Test should be performed before this self test.

Information on the "Configuration" printout (CANCEL Key Self Test) will be used with the results of this self test to determine the best Darkness Setting for a specific media/ribbon combination.

The FEED Key Self Test printout will print at various PLUS or MINUS Darkness settings relative to the Darkness value shown

on the Configuration Label. This test makes 7 printouts at speeds "A" (2" per second) and "C" (4" per second). Inspect these printouts and determine which one has the best darkness setting for the application.

The value on that printout is added to (plus) or subtracted from (minus) the "Darkness" value specified on the Configuration printout.

The resulting numeric value (0 to 30) is the best darkness value for that specific media/ribbon combination.

The plus or minus value can be entered by the operator while performing a Label Darkness Adjustment procedure. Enter the PLUS value by pressing the UP (FEED) key, or enter the MINUS value by pressing the DOWN (CANCEL) key the appropriate number of times.

Optionally, the Darkness value can be programmed into the ZPL II formats sent to the printer.



Figure 3.4 Feed Key Test Sample Printout

FEED Key and PAUSE Key

Pressing these two keys at the same time, while turning the Power ON, temporarily resets the Printer Configuration to the factory default values. These values will be active until Power is turned OFF. **Whenever the printer is reset to factory defaults, a Media Calibration procedure must be performed immediately.**

MODE Key Test

This test places the printer in the Communications Diagnostics Mode. In this mode, the printer prints the ASCII characters and their corresponding hexadecimal values for any data received from the host computer. A typical printout from this test is shown in Figure 3.5.

Note: This label will be inverted when printed.)

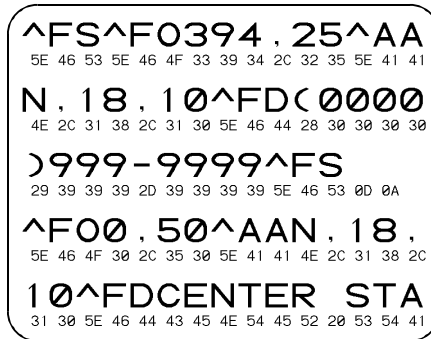

Figure 3.5 Results of Communications Diagnostic Test

PAUSE Key and CANCEL Key Test

This test prints a maximum of 500 Head Test labels. Each label backfeeds prior to printing and feeds forward to the rest position after printing. A serialized number prints on each label. Press the PAUSE key or turn the printer power OFF to stop printing. The labels look like the one in Figure 3.3 except that a serialized number will print on each label.

FEED Key and CANCEL Key Test

This test prints seven pre-programmed label formats at different speeds. The printer automatically pauses after each format. The sequence of label formats is as follows.

Label Format	Qty	Speed	Label Format	Qty	Speed
Left Ribbon Wrinkle Test	20	D	Head Temperature Test	10	D
Right Ribbon Wrinkle Test	20	D	Upper Smear Test	10	D
C39 Wrinkle Test	20	D	Lower Smear Test	10	D
Left Ribbon Wrinkle Test	20	A	Usable Area Test	10	A
Right Ribbon Wrinkle Test	20	A	Head Temperature Test	10	A
C39 Wrinkle Test	20	A	Upper Smear Test	10	A
Usable Area Test	10	D	Lower Smear Test	10	A

Extended Printer Diagnostics

Extended diagnostic tests are available. The maintenance manual provides the information needed to perform these additional tests.

Battery Replacement (200M Only)

One of the factory-installed options for the 200M is the Battery Backed-up 256 KB Non-volatile SRAM Memory. The battery used with this option is a 3 VDC lithium battery.

It is recommended that a qualified service technician replace this battery since it requires internal access to the electronics area of the printer. Further information regarding the replacement of this battery is contained in the Maintenance Manual, Vol. 1: General Maintenance.

CAUTION: Danger of explosion if battery is incorrectly replaced. Replace only with the same or equivalent type recommended by the manufacturer. Discard used batteries according to the manufacturer's instructions.



Configuration and Calibration

Option Switches

These switches are located at the rear of the printer above the Signal Interface Cable Connection. See Figure 4.2.

In the tables on the following page, an “R” means the switch is OFF (positioned to the right), while an “L” means the switch is ON (positioned to the left). All switches are in the OFF position when the printer is shipped from the factory.

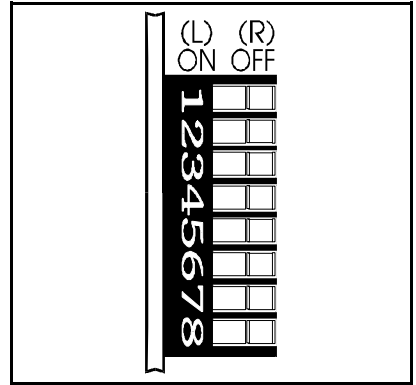

Figure 4.1 Option Switches

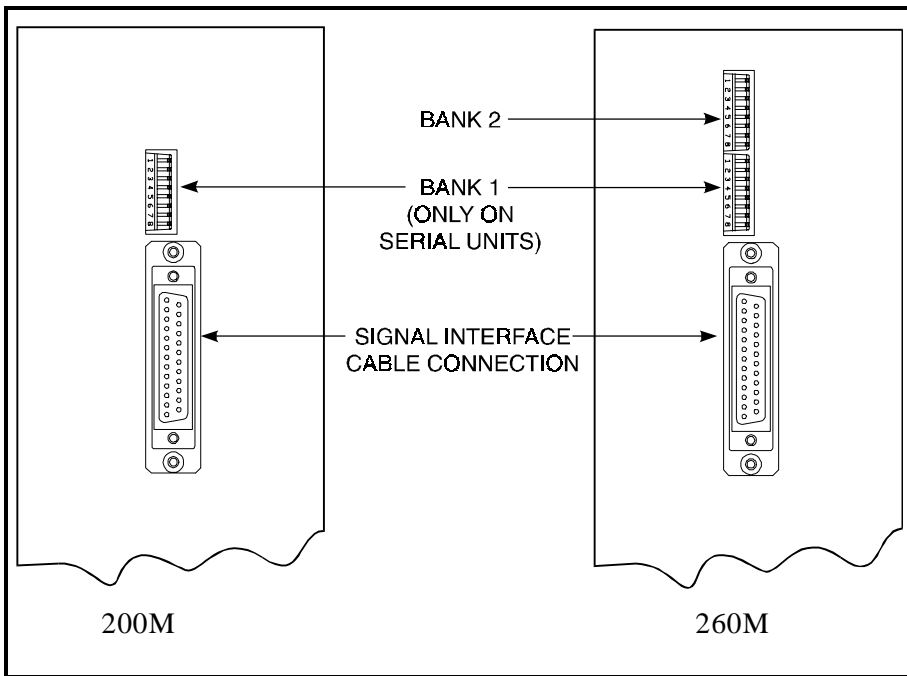

Figure 4.2 Location of Option Switches

Bank 1 (For Serial-Interface Printers Only)

The M-Series Printer, with the RS-232 Serial Interface, uses eight miniature switches located on the rear of the printer, above the Signal Interface Cable Connector. The ON/OFF positions of these switches establish some of the Printer Configuration Parameters.

Bank 1 switches must be properly positioned to establish serial data communications with the host computer. Thereafter, the position of these switches should not be changed.

Note: Parallel-interface printers do not require these configuration parameters, therefore they have no Bank 1 switches.

If these switches are in the proper position to match the communication configuration of the host computer, and the printer is not receiving data, refer to the **Interconnections** Section and make sure the correct interface cable is being used.

Note: The printer is fixed at 1 stop bit, so make sure that your host device is also set at 1 stop bit.

Bank 1 (Serial-Interface Printers Only)	
Switch 3 2 1	Baud Rate
R R R	9600 baud
R R L	19200 baud
R L R	110 baud
R L L	300 baud
L R R	600 baud
L R L	1200 baud
L L R	2400 baud
L L L	4800 baud
Switch 4	Data Bits <i>(Must be set to 8 Data Bits to use Code Page 850.)</i>
R	7 Data bits
L	8 Data bits
Switch 6 5	Parity <i>(If you choose 7 data bits, you must choose either even or odd parity.)</i>
R R	Even parity
R L	Parity disabled
L R	Odd parity
L L	Parity disabled
Switch 7	Communication Handshake Control
R	XON/XOFF control
L	DTR/DSR control
Switch 8	Error Detection Protocol
R	No error detection
L	Error detection active

Table 4.1

Bank 2 (260M Printers Only)

These switches can manually override any ZPL II commands that affect print mode, media mode, and media type. They can also override settings established during the calibration procedure. Reasons why you might want to use these override switches:

Bank 2 (260M Printers Only)	
Switch 3 2 1	Print Mode
R R L	Reserved
R L L	Tear-Off
L R L	Peel-Off
L L L	Rewind
- - R	Override is disabled
Switch 6 5 4	Media Mode
R R L	Black-mark sensing mode
R L L	Transmissive sensing mode with non-continuous media (detects a web/notch)
L L L	Transmissive sensing mode with continuous media
- - R	Override is disabled
Switch 8 7	Media Type
R L	Thermal transfer
L L	Direct thermal
- R	Override is disabled

Table 4.2

- Troubleshooting. By using these switches, you know beyond a doubt what operating mode your printer is in.
- Lets you use a single ZPL II label format for many different printers—without worrying if the format contains a mode command that is inappropriate for your printer configuration.
- Some third-party label design software packages work better if these switches control the mode.

If you do not want to override ZPL II or the calibration settings, disable one or more of the override options by setting switches 1, 4, and/or 7 to the R (OFF) position and turning the power ON. With these disabled, the 260M will require ZPL II commands and/or re-calibration to set print mode, media mode, and/or media type.

To override, set the switches to one of the modes shown in the table. If you are in the process of printing, this change takes effect on the next label printed. If you change the switches from active to disabled after printer power-up, the printer remains in the current mode until a ZPL II command or re-calibration changes the mode.

Configuration Mode

The Configuration Mode allows you to fine-tune the internal printer configuration settings for your application. In this mode, you can change the following parameters:

- Printing darkness
- Rest position of the media with respect to the “web” or “interlabel gap”
- Position of printing relative to the top of the label
- Media and Ribbon Sensor values
- Label length
- Printing method
- Media type (continuous or non-continuous)

You can get a printout of the printer configuration (the values for each of these parameters) at any time by performing the CANCEL Key Self Test (See Chapter 3).

If it is ever necessary to reset the printer configuration to the factory defaults, refer to the “FEED Key and PAUSE Key” Self Test description in Chapter 7.

The ZPL II Programming Guide contains information on instructions which may be sent to the printer to disable the MODE key and set specific label format values for each of these parameters. If you are not using ZPL II, refer to the instructions provided with your software package to determine if you also have this capability.

Calibration

IMPORTANT: Perform the Calibration Procedure when media and ribbon are first installed and each time a different type of media or ribbon is installed.

During this procedure, the printer automatically determines the media type, label length, media and ribbon sensor settings, and printing method. Media type is determined by sensing either continuous or non-continuous media as blank labels move through

the printer. If non-continuous media is sensed, Label Length is also calibrated. If ribbon is sensed, the Thermal Transfer Print Method is configured. If no ribbon is present, the Direct Thermal Print Method is configured.

The results of this calibration are stored in the printer's memory. These parameters will remain in effect until the next calibration is performed. The Printer Configuration Printout, which prints when the CANCEL Key Self Test is performed, lists these results as well as other printer parameters.

Note: If the printer is in the Peel-Off Mode, the operator must “catch” the labels as they are peeled away from the backing during this procedure.

1. Load media and ribbon (if used). Make sure the Media Sensor is properly positioned (see Chapter 7 “Adjustments”).

IMPORTANT: To use a 260M in Black-Mark Sensing Mode, make sure you set the Bank 2 DIP switches appropriately (see page 4-3).

2. Turn the power switch ON. When the Power ON Self Test is complete, the POWER, PAUSE, and PAPER/RIBBON lights will be ON.
3. Press the MODE key 3 times briefly. PAUSE and CALIBRATE lights turn ON.
4. Press UP (FEED Key) to calibrate. The printer feeds some media. The MODE lights will flash ON and OFF to indicate that the settings have been saved in memory.
5. Press PAUSE to exit PAUSE mode. PAUSE light turns OFF.

Adjust the Print Darkness

This procedure sets the darkness of the printing on the label. Use the lowest setting which provides the necessary print quality.

1. Press the MODE key. PAUSE and DARKEN lights turn ON.
2. Press UP or DOWN to adjust the current setting.
3. Press the MODE key 3 times. The MODE lights will flash ON and OFF to indicate that the settings have been saved in memory.
4. Press PAUSE to exit PAUSE mode. PAUSE light turns OFF.

Adjust the Media Rest Position

This procedure sets the end-of-label position relative to the Tear-Off Bar or Cutter.

1. Press the MODE key twice briefly. PAUSE and POSITION lights turn ON.
2. Press UP or DOWN to adjust the current setting.
3. Press the MODE key twice briefly. The MODE lights will flash ON and OFF to indicate that the settings have been saved in memory.
4. Press PAUSE to exit PAUSE mode. PAUSE light turns OFF.

Adjust the Position of the Top of the Label

This procedure positions the printing on the label relative to the top edge of the label.

1. Press the MODE twice briefly then press and hold for about 5 seconds until the lights change. PAUSE and DARKEN and CALIBRATE lights turn ON.
2. Press UP or DOWN to adjust the current setting.
3. Press the MODE key twice briefly. The MODE lights will flash ON and OFF to indicate that the settings have been saved in memory.

Press PAUSE to exit PAUSE mode. PAUSE light turns OFF.

System Components

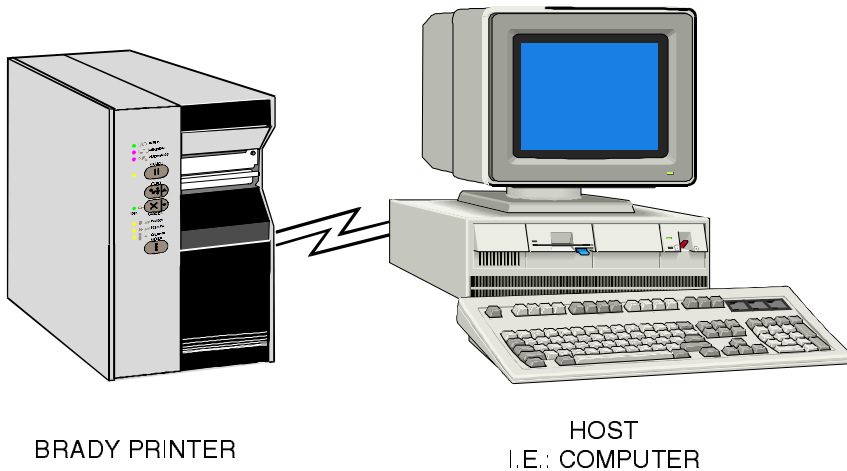

Figure 5.1 System Components

System Considerations

Communications Code

The Brady M-Series Printer sends and receives American Standard Code for Information Interchange (ASCII). This code consists of 128 characters (256 for Code Page 850) including upper and lower case letters, punctuation marks, and various control codes.

Interfaces

The method of interfacing the Brady M-Series Printer to a data source depends on the communication options installed in the printer. Depending on how the printer was ordered, the interface is either an RS-232 serial data port or a parallel port.

Data Specifications

When communicating via the serial data port (RS-232), the baud rate, number of data bits, and the parity are user-selectable (see Section 4 for acceptable setting combinations). Parity only applies to data transmitted by the printer, since it ignores the parity of received data. The M-Series Printer is fixed at 1 stop bit, so make sure that your host is also set at 1 stop bit.

When communicating via the parallel port, the previously mentioned parameters are not considered.

RS-232 Serial Data Port

The connections for the standard interface are made through the DB25S connector on the rear panel. For all RS-232 input and output signals, the M-Series Printer follows both the Electronics Industries Association's (EIA) RS-232 and the Consultative Committee for International Telegraph and Telephone (CCITT) V.24 standard signal level specifications.

Pin No.	Description
1	Frame Ground for Cable Shield
2	TXD (Transmit Data) output from the printer
3	RXD (Receive Data) input to the printer
4	RTS (Request To Send) output from the printer
6	DSR (Data Set Ready) input to the printer
7	Signal Ground
20	DTR (Data Terminal Ready) output from the printer
Note: <i>Pins 5, 8, 10-19, and 21-25 are not used and are unterminated.</i>	

Table 5.1 RS-232C Pinouts

Hardware Control Signal Descriptions

Request To Send (RTS) is a Control Signal from the M-Series Printer to the host computer. RTS is always in the ACTIVE condition (positive voltage) whenever the printer is powered ON.

Data Set Ready (DSR) is a control signal from the host computer to the printer. When DSR is in the ACTIVE condition (positive voltage), the printer can transmit status to the host. When CTS is in the INACTIVE condition (negative voltage), the printer will not transmit any data.

When DTR/DSR handshaking is selected, via DIP Switch # 7 at the rear of the printer, the Data Terminal Ready (DTR) Control Signal output from the printer controls when the host computer may send data. DTR ACTIVE (Positive voltage), permits the host to send data. When the printer places DTR in the INACTIVE (negative voltage) state, the host must not send data.

Note: *When XON/XOFF handshaking is selected, data flow is controlled by the ASCII Control Codes DC1 (XON) and DC3 (XOFF). The DTR Control lead will have no effect.*

RS-232 Cabling Requirements

The required cable must have a 25-pin "D" Type (DB25P) male connector on one end, which is plugged into the mating (DB25S) female connector located at the upper rear of the printer. Tighten the locking screws.

The other end of the Signal Interface Cable connects to an appropriate point at the host computer. This cable will be one of two types depending on the specific interface requirements. Refer to the following pages for information on the standard and null modem cables.

Data cables must be fully shielded and fitted with metal or metallized connector shells. Shielded cables and connectors are required to prevent radiation and reception of electrical noise.

To minimize electrical noise pickup in the cable:

1. Keep data cables as short as possible.
2. Do not bundle the data cables tightly with power cords.
3. Do not tie data cables to power wire conduits.

Interconnect to DTE Devices

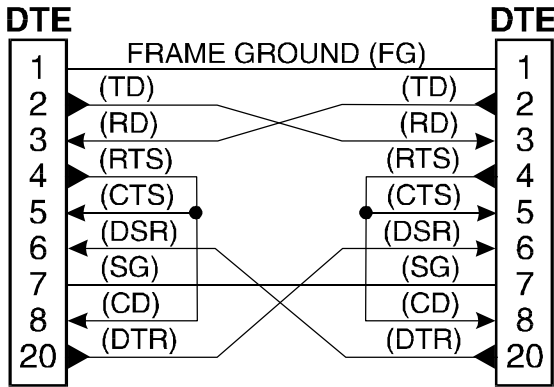

Figure 5.2 DTE to DTE Connections

The printer is configured as Data Terminal Equipment (DTE). To connect the printer to other DTE devices (such as the serial port of a PC), use an RS-232 Null Modem (crossover) cable. Figure 5.2 illustrates the connections required for this cable.

Interconnect to DCE Devices

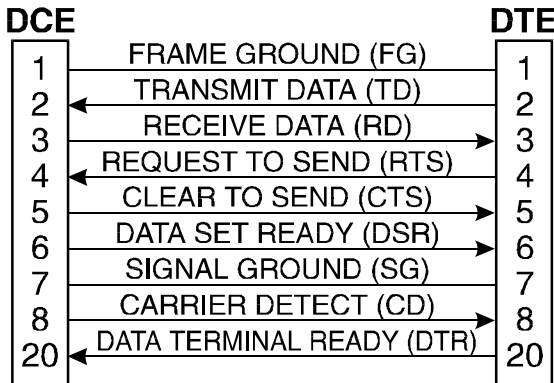

Figure 5.3 DCE to DTE Connections

When the printer is connected via its RS-232 interface to Data Communication Equipment (DCE) such as a modem, use a standard RS-232 (straight-through) interface cable. Figure 5.3 illustrates the connections required for this cable.

Parallel Cabling Requirements

The required cable must have a standard 36-pin parallel connector on one end, which is plugged into the mating connector located at the upper rear of the printer. The parallel interface cable is connected using bail clips, instead of screws, in a similar position to that of the serial data cable.

The other end of the parallel interface cable connects to an appropriate point at the host computer.

Data cables must be fully shielded and fitted with metal or metallized connector shells. Shielded cables and connectors are required to prevent radiation and reception of electrical noise.

To minimize electrical noise pickup in the cable:

1. Keep data cables as short as possible.
Maximum length: 10 ft.
2. Do not bundle the data cables tightly with power cords.
3. Do not tie data cables to power wire conduits.

Parallel Interface

The Parallel Interface provides a means of communication which is typically faster than the previously mentioned Serial Interface method. In this method, the bits of data which make up a character are sent all at one time over several wires in the cable, one bit per wire.

Data signals are defined as either HIGH or LOW, while Control Signals are either Active or Inactive. Some Control Signals are active HI while others are active LOW. The voltage levels which represent these conditions are:

<u>Data Signal</u>	<u>Voltage Level</u>
HIGH	+5 VDC
LOW	0 VDC

Signal Descriptions

The following chart provides a description of each of the pins in the parallel connector. A standard parallel data cable will provide the required interconnection between the computer and the printer.

IEEE 1284-B Connector Pin Assignments	
Pin No.	Description
1	The nStrobe printer input has internal 3.3 k Ω pull-up resistors to 5 V (I_{OL} = 1.5 mA) and is designed to receive a signal driven open collector $V_{OL} \leq 0.8$ V. This pin is a signal from the host computer. The nStrobe input is debounced on a LOW going edge to require an active width greater than 0.5 μ s before data is latched.
2 - 9	Data inputs have TTL input characteristics with internal 3.3 k Ω pullups and represent 1 TTL unit load or less. The Data inputs are positive logic with a HIGH voltage level corresponding to a logic 1. Pin 2 through Pin 9 = D0 through D7 respectively.
10	The nAck output is an active LOW pulse used to indicate termination. nAck is a driven open collector with a 3.3 k Ω internal pull-up. The output sinks 7 mA to a $V_{OL} \leq 0.4$ V.
11	The Busy output is active HIGH whenever the printer cannot accept data due to any normal or abnormal condition, including buffer overflow, head open, over temperature, and media error conditions. Busy is a driven open collector with a 3.3 k Ω internal pull-up. The output sinks 7 mA to a $V_{OL} \leq 0.4$ V.
12	The PError signal is active HIGH whenever the printer is out of media or ribbon.
13	The Select signal function is determined by an additional configuration option which becomes active when the port is present. In the default condition, Select is active HIGH whenever the parallel port is powered up and the parallel port is enabled. In the non-default condition, Select will go active LOW whenever the printer is printing.
14	nAutoFd (not connected)
15	Not defined
16	Logic Gnd
17	FRAME GROUND is at the same potential as Logic Gnd (pin 16).
18	FUSED 5 V - 1 A maximum.
19 - 30	SIGNAL GROUNDS are the Logic Grounds and Returns for all input and output signals.
31 - 35	NOT USED - These leads should be left unconnected.
36	NSelectIn (not connected)

Preventive Maintenance

Overview

This section contains Preventive Maintenance information for the Brady M-Series Printer. These procedures may be performed by the operator.

Cleaning

Exterior Surfaces

The exterior surfaces of the printer may be cleaned as required by using a lint free cloth. Do not use harsh or abrasive cleaning agents or solvents. If necessary, a mild detergent solution or desktop cleaner may be used sparingly.

Interior

Remove any accumulated dirt/lint from the interior of the printer using a soft bristle brush and/or vacuum cleaner. This area should be inspected after every four rolls of media.

The cleaning supplies are found in the Printer Cleaning Kit (PCK-2).

AREA	METHOD	INTERVAL
Printhead	Alcohol	After every roll of media (or 500 ft. of fanfold media) when printing direct thermal or after every roll of ribbon when printing in thermal transfer mode.
Platen Roller	Alcohol	
Upper and Lower Media Sensors	Air Blow	
Media Path	Alcohol	
Ribbon Sensor	Air Blow	
Peel/Tear Bar	Alcohol	As needed.
Label Available Sensor	Air Blow	Monthly.

Table 6.1 Cleaning Schedule

Printhead and Platen Roller

Inconsistent print quality, such as voids in the bar code or graphics, may indicate a dirty printhead. For optimum performance, Brady recommends performing the cleaning procedure on page 6-3 after every roll of ribbon (after every roll of media, for direct thermal printing).

Note: Label Available Sensors are shown for location purposes only. They are not standard on all printers.

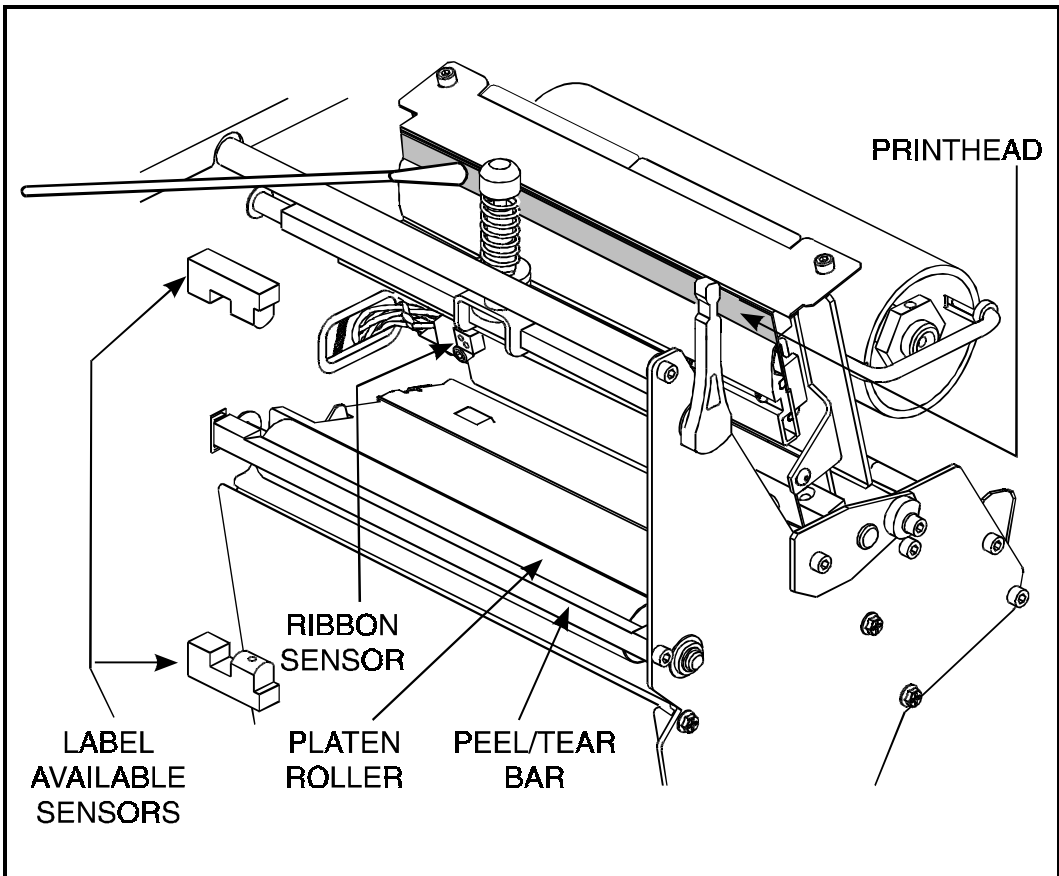

Figure 6.1 Printhead Cleaning

It is not necessary to turn printer power OFF prior to cleaning. If power is turned OFF, all label formats, images, and parameter settings stored in the printer's formatting RAM will be lost. Permanent parameter settings stored in EEPROM will be retained. When power is turned back ON, it may be necessary to reload some items.

To clean the printhead and platen roller, open the media compartment door, refer to Figure 6.1, and perform the following steps:

1. Open printhead by moving printhead handle to the OPEN position.
2. Remove the media and ribbon (if present).
3. Moisten an applicator tip with Brady USA, Inc.-recommended solvent and wipe the print elements from end to end. (The print elements form the gray/black strip just behind the chrome strip. See Figure 6.1.) Allow a few seconds for the solvent to evaporate.
4. Rotate the platen roller and clean thoroughly with solvent.
5. Brush/vacuum any accumulated paper lint and dust away from the rollers and the media and ribbon sensors.
6. Reload ribbon and/or media, close and latch the printhead, restore power (if necessary) and continue printing after the self test.

Media, Ribbon, and Label Available Sensors

These sensors should be cleaned on a regular basis to ensure proper operation of the printer. To locate the position of these sensors, refer to Figures 6-1, 7-2, and 7-3.

Lubrication

CAUTION: Some commercially available lubricants will damage the printer if used.

Lubrication of the Brady M-Series Printer should be performed by a qualified service technician according to the directions provided in the Volume 1 of the Maintenance Manual.



Toggle Positioning

Note: The 200M has one toggle, the 260M printer has two toggles.

The toggle(s) should be positioned to provide even pressure on the media. Toggles are positioned by sliding them left or right to the desired location. On the 200M, the single toggle should normally be positioned over the center of the media. If your printer has two toggles and you are using media too narrow to accommodate both toggles, position one toggle over the center of the media and decrease the pressure on the unused toggle.

Printhead Pressure Adjustment

If printing is too light on one side, or if thick media is used, you may need to adjust the printhead pressure. Refer to Figures 7.1 and 7.2 and follow the procedure below.

1. Perform a PAUSE Key Self Test.
2. Lower the Darkness Setting until the printing is gray.
3. Loosen the Toggle Position locking nut(s) located inside the “U” shaped bracket at the top of the toggle.
4. Slide toggle(s) in the direction of the light printing.
5. Using the knurled Adjusting Nuts on the shaft(s) of the toggle(s), increase or decrease spring pressure until the left and right edges of printed area are equally dark.
6. Increase Darkness to optimum level for the media being used.
7. Retighten the Toggle Position locking nut(s).

Note: Printhead life can be maximized by using the lowest pressure that produces the desired print quality.

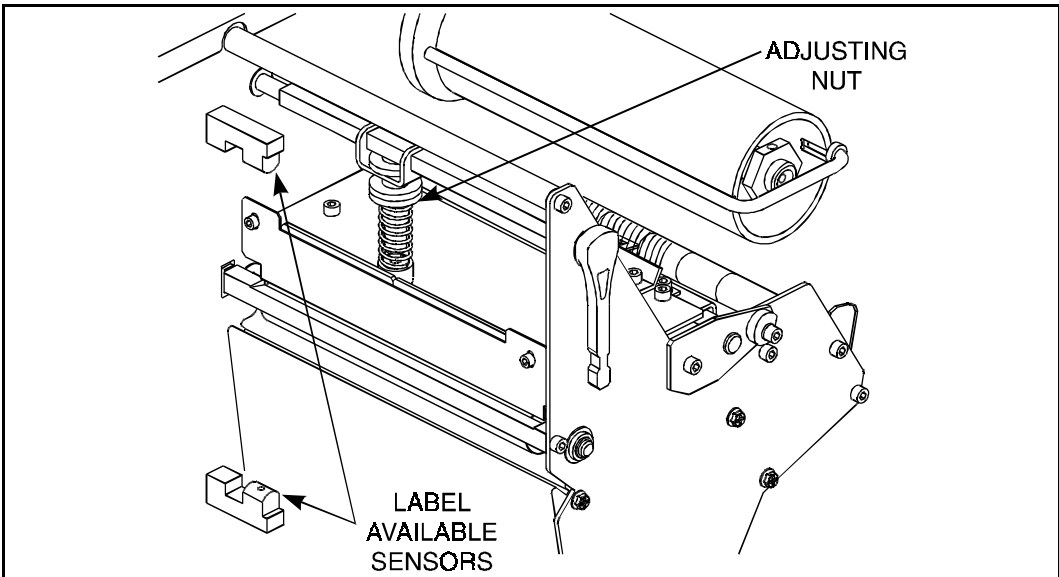

Figure 7.1 Printhead Pressure Adjustment

Black-Mark Media Sensor Position Adjustment

This sensor position requires no adjustment or calibration by the user.

Transmissive Media Sensor Position Adjustment

The transmissive media sensor senses either the “web” between labels or a hole or notch in the media to determine the length of the label or ticket.

The locator is a device designed to make media sensor positioning easier and more accurate. The locator minimizes the position the upper media sensor can maintain. See Figures 7.2 through 7.5. All Brady media requires an upper media sensor position which can be attained with the locator in place. The lower media sensor should remain at its factory-set position 0.6" away from the fire wall at all times.

Other brands of media may require the locator to be removed. In those cases, refer to “Upper Transmissive Media Sensor Position

Adjustment” and “Lower Media Sensor Position Adjustment” later in this chapter.

Transmissive Media Sensor Positioning Using the Locator

Brady materials require only two distinct upper media sensor positions. These two positions are shown as position A and position B in Figure 7.4.

The lower media sensor should not be repositioned when using Brady media; it should remain at its factory-set position of 0.6" away from the fire wall at all times.

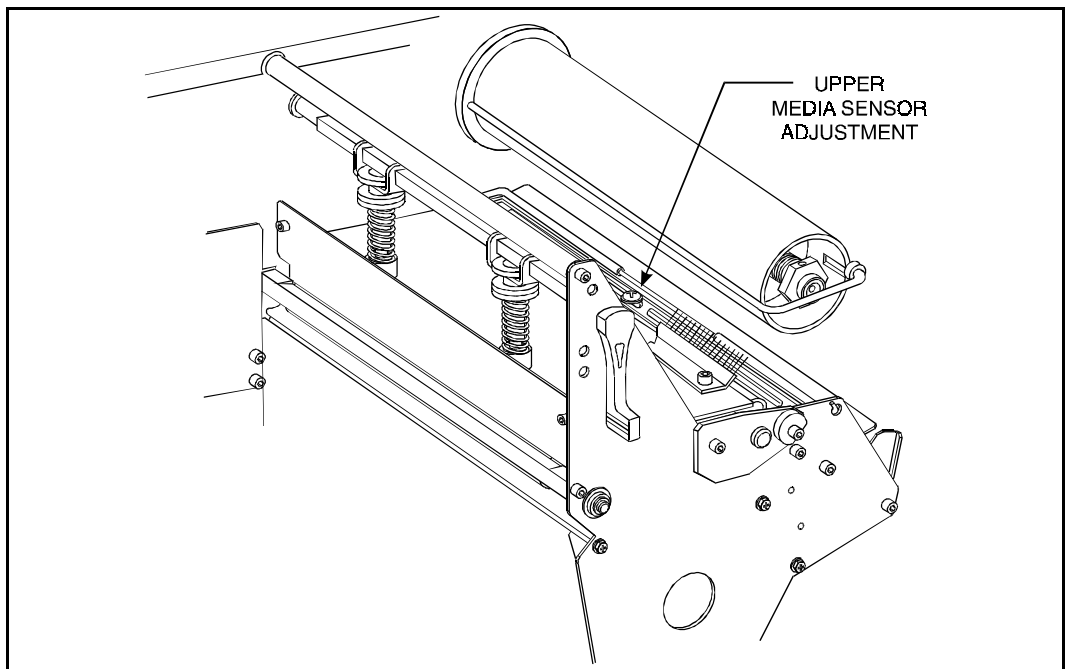

Figure 7.2 Upper Media Sensor

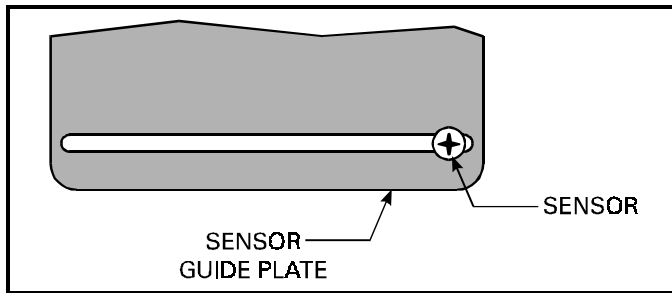

Figure 7.3 Sensor Guide Plate

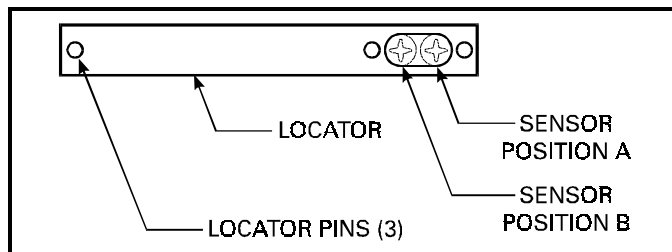

Figure 7.4 Locator

Refer to Figures 7.3 and 7.4 while performing this procedure.

1. Position the upper media sensor (approximately 1 inch from the sensor guide plate edge) such that as the locator is dropped in place, the sensor (Phillips head screw) will protrude through the locator slot.
2. Place the locator on the sensor guide plate so that the three locator pins (see Figure 7.4) fit securely in the sensor guide plate slot. Make sure the locator slot is positioned to the inside of the printer near the printer fire wall.

Note: The magnetic surface of the locator will eliminate the chance of it becoming accidentally dislodged.

3. The sensor can now be easily repositioned to meet the media requirements:
 - Position A is for all Brady THT products except Per-mashield and Permasleeve.
 - Position B is for Brady Per-mashield and Brady Per-masleeve.

Upper Transmissive Media Sensor Position Adjustment

To adjust the upper media sensor to accommodate non-Brady-brand media, refer to Figure 7.2 and follow these steps.

1. Remove the ribbon and locate the Upper Media Sensor.
2. Loosen the Phillips head screw.
3. Slide the upper sensor along the slot to the desired position. When using media that has a web between labels, position the media sensor anywhere along the web (except if you have labels with rounded corners, do not position the sensor where the rounded corners of the label might be detected). When using tag stock, position the upper sensor directly over the hole or notch.
4. Tighten the Phillips head screw.

260M only: To adjust the upper section of the Transmissive Media Sensor for the outside half of the media width, call a service technician.

Lower Transmissive Media Sensor Position Adjustment

To adjust the lower media sensor, follow these steps.

1. Locate the lower media sensor assembly (a spring clip holding a small printed-circuit board) under the rear idler roller.
2. Position the sensor so that the two brass-colored infrared emitters are under the upper sensor by sliding it in its slot.
3. Gently pull wires out of the printer frame as required. (Wires should have a little slack.)

Note: If the sensor is being moved inward and a large loop of wire develops, remove the cover from the electronics side of the printer and gently pull the wires through. It is important that the wires be properly clamped so that they are not rubbed by any belts.

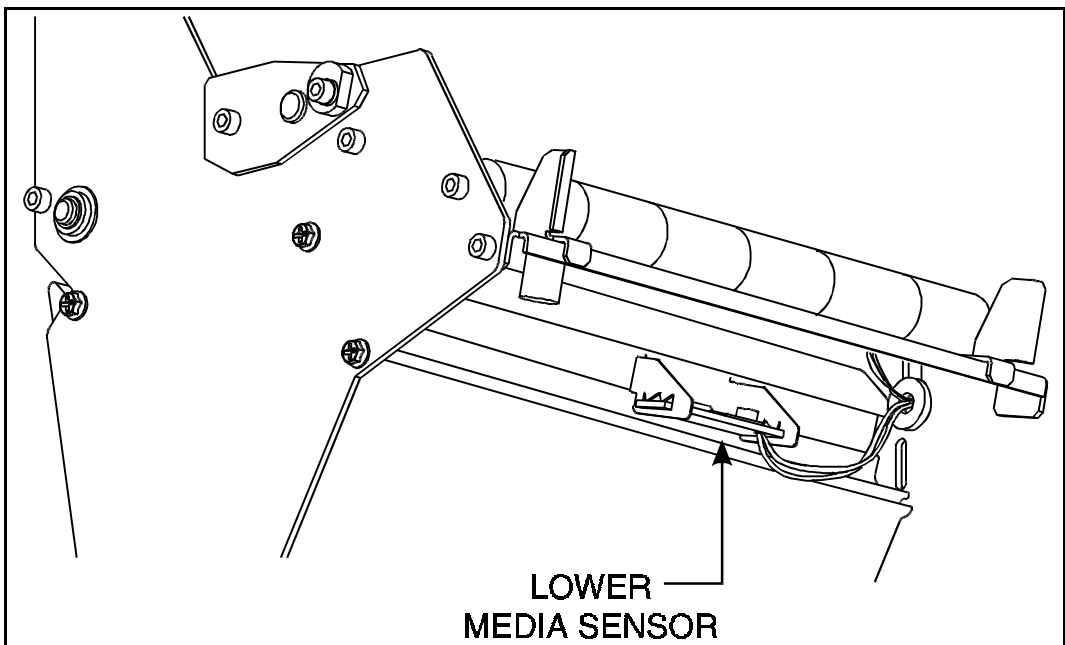

Figure 7.5 Lower Transmissive Media Sensor Locations

Media and Ribbon Sensor Sensitivity Adjustment

Note: This adjustment is initially set during final printer calibration. Under normal circumstances, further adjustments should not be necessary. The exception to this might be the use of media with exceptionally thick or thin backing, which could require re-adjustment of the Sensor Sensitivity.

This adjustment may need to be performed if the Paper/Ribbon light comes ON with (1) the media and ribbon properly installed for thermal transfer mode or (2) media only properly installed for the direct thermal mode.

The following procedure is used to perform the Media and Ribbon Range Adjustment.

1. Turn the printer OFF.
2. Open the Printhead.
3. Remove as many labels as needed to create at least 12 inches of blank backing material. Load the blank backing material under the printhead.

Note: Be sure that blank backing material is positioned between the upper and lower Media Sensors.

4. Remove the ribbon. (Sliding it as far from the printer wall as possible will have the same effect as removing it.)
5. Close the Printhead.
6. Hold the Pause, Feed, and Cancel keys depressed while turning the printer ON. Once the printer is ON, release the keys.
7. The following two sets of lights will begin flickering, signifying that the adjustment has been made.

The PRINTHEAD and PAPER/RIBBON lights.
The DARKEN and POSITION lights.

Note: If only one pair of lights is flickering, it indicates that the adjustment was not successful. Go back to Step 1 and start over.

8. Open the Printhead.

- Pull the media out of the printer until a label is positioned under the Printhead. Move the ribbon back to its normal position.

Note: Be sure that label is positioned between the upper and lower Media Sensors.

- Close the Printhead.
- Press the MODE key to print a Media and Sensor Profile and save the new values. (See Figure 7.4.)
- Perform the Media Calibration procedure in chapter 4.

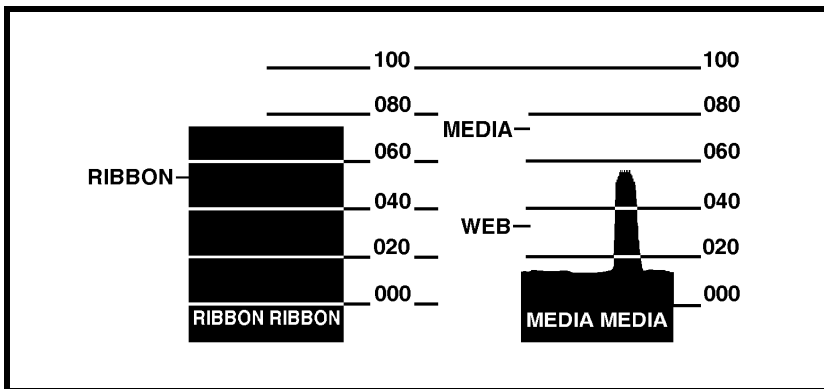

Figure 7.6 Media Sensor Profile Sample Printout

Troubleshooting

This section contains troubleshooting charts used to localize and repair the printer when faults occur. The procedures called out in the ACTION column may be performed by the operator or by a service technician when indicated.

**Brady's Technical Support Telephone Number is:
(800) 643-8766.**

SYMPTOM	DIAGNOSIS	ACTION
All lights never light.	No AC Power applied to the Printer.	Ensure that the AC Power Cable is connected to a working voltage source.
	Faulty AC Power Fuse.	Refer to Installation Section for Fuse replacement procedures.
	No voltage available from the internal Power Supply.	Call a service technician.
Printer locks up when running Power On Self Test.	An improper configuration was set.	Reload factory defaults. Then, set correct parameters. See Operation Section.
POWER light ON, other lights all OFF or all ON and the printer locks up.	ROM CRC Test has failed.	Call a service technician.
CALIBRATE light is OFF but all other lights are ON.	Dynamic RAM failed.	Call a service technician.
CALIBRATE light and POSITION light OFF but all other lights ON	FONT ROM Error	Call a service technician
PRINthead light is ON, printing continues.	Printhead Under Temperature Condition.	Wait until printhead warms up. If condition persists and print quality is affected, move printer to a warmer environment. If print quality is acceptable, no action is required.

SYMPTOM	DIAGNOSIS	ACTION
Printer stops. PAUSE light and PAPER/RIBBON light both ON.	Media incorrectly loaded or not loaded.	Load media correctly. See Media Loading in Installation Section.
	Misadjusted Media Sensor. Media not Calibrated.	Check Position and Sensitivity of Media Sensor and/or Calibrate Media. See Adjustments in Configuration and Calibration Section.
Printer stops. PAUSE light ON and PAPER/RIBBON light FLASHING.	Ribbon incorrectly loaded or not loaded.	Load ribbon correctly. See Ribbon Loading in Installation Section.
	Malfunctioning Ribbon Sensor.	Call a service technician.
Printer stops. PAUSE light ON and PRINTHEAD light FLASHING.	Printhead is not fully closed.	Close printhead completely.
	Printhead Open Sensor not detecting its position flag.	Call a service technician.
Printer stops. PAUSE light and PRINTHEAD light both ON.	Printhead element is overheated. (200M or 260M)	Printer resumes printing when the printhead element cools. If condition persists, move printer to a cooler environment.
	On the 260M only, the power supply is overheated.	Printer resumes printing when the power supply cools. If condition persists, move printer to a cooler environment.
Dots missing in printed area of label.	Printhead element going bad.	Call a service technician.
Loss of printing registration on labels.	Possible Media Sensor or Calibration problem.	Adjust Media Sensor Position or Calibrate Media. Call a service technician if necessary.
	Printer set for non-continuous media, but continuous media loaded.	Set printer for correct media. See Installation Section.
For Peel-Off Mode.	Improperly adjusted Media Edge Guides.	Refer to Installation Section.
Excessive vertical drift in top-of-form registration.	Incorrect media loading.	See Media Loading in the Installation Section.

SYMPTOM	DIAGNOSIS	ACTION
Light vertical lines approximately 0.005" wide running through all labels.	Dirty head or ribbon rollers.	See Printhead Cleaning in Preventive Maintenance Section.
	Defective printhead elements.	Call a service technician.
Light printing or no printing on the left or right side of the label.	Printhead needs balancing.	Adjust Toggle Pressure and/or position.
Short printed lines at 45° to label edge on left or right side of label.	Too much printhead pressure.	Adjust Toggle Pressure and/or position.
Fine gray lines on blank labels at angles.	Wrinkled ribbon.	See Wrinkled Ribbon in this Table.
Truncated print, no print, or FEED button operates incorrectly while using non-continuous media.	Media or ribbon improperly loaded.	See Media and Ribbon Loading instructions in the Installation Section.
Long tracks of missing print on several labels.	Wrinkled ribbon.	See Wrinkled Ribbon in this Table.
	Print element damaged.	Call a service technician.
In Peel-Off Mode, skewed or stuck labels.	Glue material from back of labels causing media movement problems.	Refer to Preventive Maintenance Section and perform maintenance and cleaning of the printer.
	Media and backing not properly aligned in printer.	Refer to Operation Section.

SYMPTOM	DIAGNOSIS	ACTION
Wrinkled ribbon.	Ribbon fed through machine incorrectly.	See Ribbon Loading in the Operation Section.
	Incorrect Darkness setting.	Set to the lowest value needed for good print quality.
	Incorrect printhead position or pressure.	Adjust Toggle Pressure and/or position.
	Media not feeding properly; it is walking from side to side.	Make sure the media is snug by adjusting the media guides.
	Continuing symptoms.	Call a service technician.
Continued wrinkled ribbon.	Strip plate needs adjusting.	Call a service technician.
Misregistration and misprint of 1 to 3 labels.	Media was pulled when motor was not moving.	Enter Calibrate Mode and recalibrate.
	Incorrect Media Sensor position.	See Media Sensor Position in the Adjustments Section.
	Media or ribbon improperly loaded.	See Media and Ribbon Loading procedures in Installation Section.
	Incorrect Media Sensor Position or Sensitivity.	See Configuration and Calibration Section.
Changes in parameter settings did not take effect.	Parameters are set or saved incorrectly.	Reload the factory defaults. Refer to the Operation Section and Calibrate the printer. Then, cycle the Power ON/OFF Switch.
	If problem continues, there may be a problem on the Main Logic Board.	Call a service technician.

SYMPTOM	DIAGNOSIS	ACTION
<p>ZPL II was sent to printer, but not recognized. The DATA light remains OFF.</p>	<p>Communications parameters or DIP Switches are set incorrectly.</p>	<p>See the Operation Section and perform MODE Key Self Test. Check for format or overrun errors. Reset Communication parameters if needed.</p>
	<p>Prefix and delimiter characters set in printer configuration do not match the ones sent in the ZPL II Label Formats.</p>	<p>Set the characters in the printer to match ZPL II format. Check Configuration Label for correct characters. If problem continues, check the ZPL II format for changed ^CC, ^CT, and ^CD instructions.</p>
<p>260M printer does not operate in the mode specified in ZPL II or by calibration</p>	<p>Bank 2 DIP switches set to override ZPL II and calibration.</p>	<p>Check Bank 2 DIP switch settings.</p>
<p>Printer does not feed media with black marks correctly.</p>	<p>Printer not set up correctly.</p>	<p>See Chapter 4—recalibrate printer. See Chapter 4 to check Bank 2 DIP switch settings.</p>
	<p>Sensor is broken. (No red light is visible when looking through the front of the printer with the printhead open.)</p>	<p>Call a service technician.</p>



Peel-Off Option

Your Brady M-Series Printer may be equipped with a Peel-Off Option. In the Peel-Off Mode, only the label backing rewinds onto the Rewind Spindle. The Peel/Tear Bar separates the label from the backing and the Label Available Sensor activates the PAUSE mode to allow the operator to remove a printed label before subsequent labels print.

Rewind Option

Your M-Series Printer may be equipped with a Media Rewind Option. This option supports **both** the Rewind and Peel-Off modes of operation.

In Rewind mode, both labels and backing material rewind internally onto a user-supplied 3 inch core. A Rewind Bracket guides the media back to the Rewind Spindle after printing.

(See Peel-Off Option for Peel-Off mode of operation.)

Optional Printer Fonts

The M-Series Printer can be optioned with character fonts in addition to those which are standard in the unit.

Only one additional font can be installed in the printer at a time. This installation should be performed by a service technician. Once installed, this font can be used in addition to the standard fonts available in the printer. Refer to the ZPL II Programming Guide for further application information.

Once an optional font is installed in the printer, the Configuration printout from the CANCEL Key Self Test will indicate the font type.

The following optional scalable smooth fonts are presently available (each is supplied as a complete set of standard, bold, italic, and bold italic styles): CG Triumvirate™, CG Times™, CG Palacio™, Futura™, Univers®.

The following Bitmap Smooth Fonts (supplied in bold style only) are presently available:

CG Triumvirate™ Bold, CG Triumvirate™ Bold Condensed, Futura™ Bold, Univers® Bold, CG Times™ Bold and CG Palacio™ Bold (Type sizes of 6pt, 8pt, 10pt, 12pt, 14pt, 18pt, 24pt, 30pt, 36pt are available.)

Examples of these Optional Fonts can be found in Appendix D.

220-240 VAC Factory Setup

Your Brady M-Series Printer will be factory set for 220-240 VAC operation if requested when the order was placed. If it is necessary to reconfigure your printer for operation at 110-120 VAC, see Chapter 2.

Memory Options

512 KB DRAM Memory Expansion

This option increases the printer's dynamic memory capacity from 1/2 MB to 1 MB. This supports longer label lengths and provides more capacity for downloadable fonts and large graphic image files. Extra memory may be installed at the factory or in the field.

256 KB SRAM Non-volatile Memory Expansion (200M Only)

Non-volatile memory provides battery backed-up storage of label formats, fonts, and/or graphics. Improves productivity by eliminating lengthy file download operations at every power-on.

6-Dot/mm Printhead (200M Only)

Optional 152 dot-per-inch printhead density satisfies specified requirements for printing UPC/EAN symbologies.

Appendix A - 240 VAC Power Cord

240 VAC Power Cord

Depending on how the Brady printer was ordered, a power cord may or may not be included when the printer is optioned for 240 VAC, 50/60 Hz. operation.

If a power cord is not supplied, you will need to obtain one with the following specifications.

1. The overall length must be less than 3.8 meters.
2. It must be rated for at least 5 amps, 250V
3. The CHASSIS GROUND (EARTH) MUST BE CONNECTED to assure safety and reduce electromagnetic interference. This is done by the third wire in the power cord.
4. The plug cap should bear the certification mark of a known international safety organization (See Figure A.2).

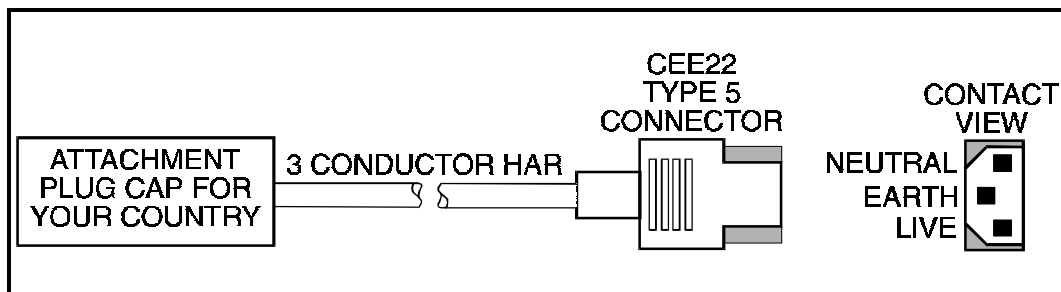

Figure A.1 AC Power Cord

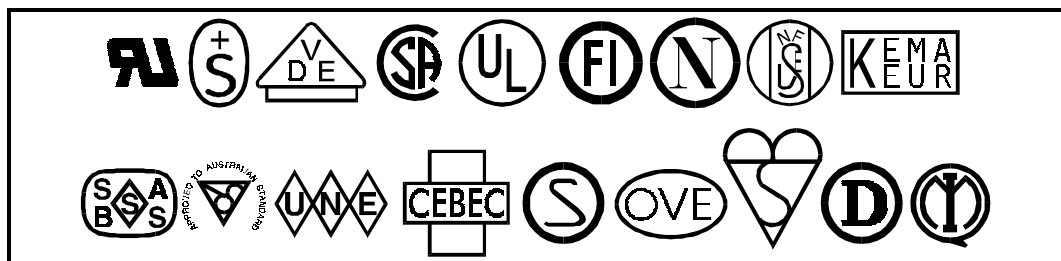

Figure A.2



Appendix B - ASCII Code Chart

HEX	CHAR	HEX	CHAR	HEX	CHAR	HEX	CHAR
00	NUL	20	space	40	@	60	'
01	SOH	21	!	41	A	61	a
02	STX	22	"	42	B	62	b
03	ETX	23	#	43	C	63	c
04	EOT	24	\$	44	D	64	d
05	ENQ	25	%	45	E	65	e
06	ACK	26	&	46	F	66	f
07	BEL	27	'	47	G	67	g
08	BS	28	(48	H	68	h
09	HT	29)	49	I	69	i
0A	LF	2A	*	4A	J	6A	j
0B	VT	2B	+	4B	K	6B	k
0C	FF	2C	,	4C	L	6C	l
0D	CR	2D	-	4D	M	6D	m
0E	SO	2E	.	4E	N	6E	n
0F	SI	2F	/	4F	O	6F	o
10	DLE	30	0	50	P	70	p
11	DC1	31	1	51	Q	71	q
12	DC2	32	2	52	R	72	r
13	DC3	33	3	53	S	73	s
14	DC4	34	4	54	T	74	t
15	NAK	35	5	55	U	75	u
16	SYN	36	6	56	V	76	v
17	ETB	37	7	57	W	77	w
18	CAN	38	8	58	X	78	x
19	EM	39	9	59	Y	79	y
1A	SUB	3A	:	5A	Z	7A	z
1B	ESC	3B	;	5B	[7B	{
1C	FS	3C	<	5C	\	7C	
1D	GS	3D	=	5D]	7D	}
1E	RS	3E	>	5E	^	7E	~
1F	US	3F	?	5F	_	7F	DEL



Shaded values are NOT recommended for Command Prefix, Format Prefix, or Delimiter characters.



Appendix C - Adjusting Bar Code Darkness

Adjusting Darkness For “In-Spec” Bar Codes

All direct thermal and thermal transfer materials do not use the same Darkness setting. The best way to check for the proper Darkness is to use a bar code verifier that actually measures bars/spaces and will calculate the PCS ratio. Without the assistance of a verifier, your eyes and/or the scanner to be used in the system may be used for picking the optimum Darkness setting. What follows is a simple yet effective method for adjusting the Darkness to print “in-spec” bar codes.

1. Load media according to the appropriate media loading and ribbon loading instructions in the Installation Section. Ensure that the proper print method has been selected.
2. To print a label for evaluation, use the following procedure:
 - A. With Power OFF, press and hold the FEED key.
 - B. Turn the printer power ON, then release the FEED key. The printer begins printing test labels.
3. Print a label, then press the PAUSE key. The label will contain several bar codes as well as other printer information. Normal bar codes are printed in a horizontal format as they feed out of the printer. Rotated bar codes are printed in a vertical format.
4. Compare the test label printed, to the bar codes in Figure C.1. If the test label appears too dark or too light, increase or decrease the Darkness setting accordingly.
5. Resume printing by pressing the PAUSE key again. Print a few labels at the new setting and verify that proper “in-spec” bar codes are being printed. Repeat steps 3, 4, and 5 until satisfied.
6. To stop printing test labels, press the PAUSE key, then press the CANCEL key.

Too Dark - Dark labels are fairly obvious. The normal bar code bars increase in size, and the openings in small alphanumeric characters may fill in with ink. It may be readable but not “in-spec”. Rotated bar code bars and spaces will run together.

Slightly Dark - Slightly dark labels are not as obvious. The normal bar code will be “in-spec”. Small character alphanumerics will be bold and could be slightly filled in. The rotated bar code spaces are small when compared to the “in-spec” code, possibly making the code unreadable..

Slightly Light - Slightly light labels are, in some cases, preferred to slightly dark for “in-spec” bar codes. Both normal and rotated bar codes will be “in-spec”, but small alphanumeric characters may not be complete.

Too Light - Light labels are obvious. Both normal and rotated bar codes have incomplete bars and spaces. Small alphanumeric characters are unreadable.

“In-Spec” - The “in-spec” bar code can only be confirmed by a verifier, but it should exhibit some very visible characteristics. The normal bar code will have complete, even bars and clear, distinct spaces. The rotated bar code will also have complete bars and clear distinct spaces. Although it may not look as good as a slightly dark bar code, it will be “in-spec”. In both normal and rotated styles, small alphanumeric characters will look complete.

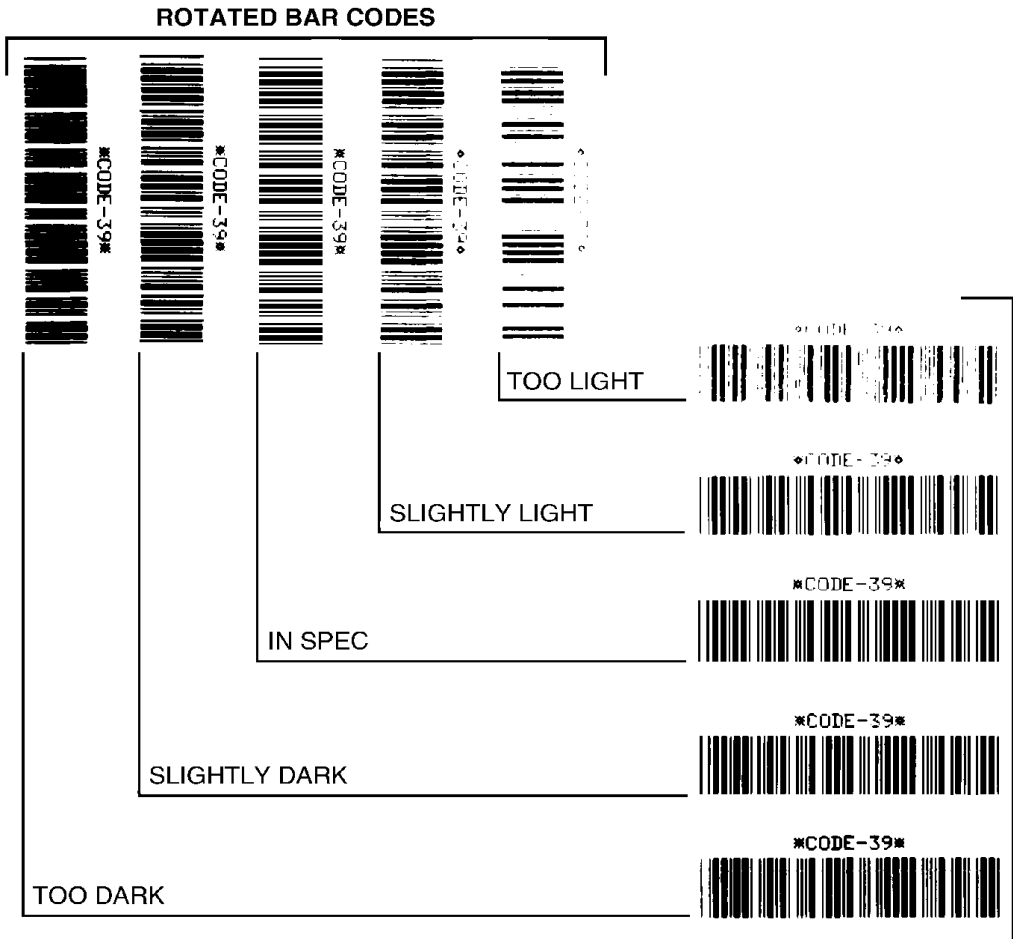

Figure C.1 Bar Code Examples



Appendix D - Optional Printer Fonts

Your printer can be optioned with character fonts in addition to those which are standard in the unit. The following pages illustrate the Optional Fonts in each of the available styles. From time to time, additions may be made to the list of available fonts. Contact Brady USA, Inc. or your sales representative for further information.

Only one additional font can be installed in the printer at a time. This installation should be performed by a service technician. Once installed, this font can be used in addition to the standard fonts available in the printer. Refer to the *ZPL II Programming Guide* for further application information.

Once an optional font is installed in the printer, the Configuration Label printed during the CANCEL Key Self Test will indicate the font type as the “Socket 2 ID”.

Optional Printer Fonts Currently Available	
Scalable Smooth Fonts (each is supplied as a complete set of Normal, Bold, Italic, and Bold Italic styles)	Bitmap Smooth Fonts (supplied only in Bold). Type sizes: 6 pt, 8 pt, 10 pt, 12 pt, 12 pt, 14 pt, 18 pt, 24 pt.
CG Triumvirate™	CG Triumvirate™
—	CG Triumvirate™ Condensed*
CG Times™	CG Times™
CG Palacio™	CG Palacio™
Futura™	Futura™
Univers®	Univers®

Compugraphic is a registered trademark and CG Triumvirate, CG Triumvirate Condensed, CG Palacio, and CG Times are all trademarks of AGFA Corporation.

Futura is a trademark of Fundicion Tipografica Neufville, S.A.

Univers is a registered trademark of Linotype AG and/or its subsidiaries.

CG Triumvirate™ - Normal 0123456789.,?!AaBbCc
CG Triumvirate™ - Bold 0123456789.,?!AaBbCcDd
CG Triumvirate™ - Italic 0123456789.,?!AaBbCcDdEe
CG Triumvirate™ - Bold Italic 0123456789.,?!AaBb

CG Times™ - Normal 0123456789.,?!AaBbCcDdEeFfGg
CG Times™ - Bold 0123456789.,?!AaBbCcDdEeFfGgHh
CG Times™ - Italic 0123456789.,?!AaBbCcDdEeFfGgHhIi
CG Times™ - Bold Italic 0123456789.,?!AaBbCcDdEeFf

CG Palacio™ - Normal 0123456789.,?!AaBbCcDdEeFf
CG Palacio™ - Bold 0123456789.,?!AaBbCcDdEeFfGg
CG Palacio™ - Italic 0123456789.,?!AaBbCcDdEeFfGg
CG Palacio™ - Bold Italic 0123456789.,?!AaBbCcDdEe

CG Futura™ - Normal 0123456789.,?!AaBbCcDd
CG Futura™ - Bold 0123456789.,?!AaBbCcDdEe
CG Futura™ - Italic 0123456789.,?!AaBbCcDdEeFf
CG Futura™ - Bold Italic 0123456789.,?!AaBbCc

Univers® - Normal 0123456789.,?!AaBbCcDdEeFf
Univers® - Bold 0123456789.,?!AaBbCcDdEeFfGgHh
Univers® - Italic 0123456789.,?!AaBbCcDdEeFfGgHh
Univers® - Bold Italic 0123456789.,?!AaBbCcDdEe

Figure D.1 Scalable Smooth Fonts (Optional)

CG Triumvirate™ - Bold 0123456789.,?!AaBbCcDd

CG Triumvirate™ Condensed - Bold 0123456789.,?!AaBb

CG Futura™ - Bold 0123456789.,?!AaBbCcDdEe

Univers® - Bold 0123456789.,?!AaBbCcDdEeFfGgHh

CG Times™ - Bold 0123456789.,?!AaBbCcDdEeFfGgHh

CG Palacio™ - Bold 0123456789.,?!AaBbCcDdEeFfGg

Figure D.2 Bitmap Smooth Fonts (Optional)

6 pt @ABCDEFGHIJKLMNO

8 pt @ABCDEFGHIJKLMNO

10 pt @ABCDEFGHIJKLMNO

12 pt @ABCDEFGHIJKLMNO

14 pt @ABCDEFGHIJKLMNO

18 pt @ABCDEFGHIJKLM

24 pt @ABCDEFGH IJ

30 pt @ABCDEFG F

36 pt @ABCDEF

Figure D.3 Point Size Examples



Appendix E - Support Services

How to Reach Us

Which number do you need?	Brady, USA
Technical Support: For questions relating to the mechanical operation of Brady equipment you already own, contact the Brady Technical Solution Center.	Phone: 1-800-643-8766
	Fax: 414-358-6767
	E-mail: bradyts@execpc.com

Technical Support

Sometime during the life of your Brady equipment you may find yourself in need of technical assistance. We provide a fully-trained technical specialists to answer any questions you may have.

Technical Support Service via Telephone

Before you call - Misunderstanding instructions or omitting a step are the most common sources of error. Please consult the manual and use the table of contents and appendixes for help.

Be prepared - Only with ALL of the information requested can we give you accurate and fast assistance. Also, you should be able to answer the following questions when you call:

- Does the printer perform all self test functions properly?
- Does the printer work properly with some equipment but not with others?
- Are the cables the same? Were the configuration settings changed?
- Is the problem limited to one label, or does it occur on all labels?

The Technical Solution Center is available Monday - Friday. Call us directly at:

1-800-643-8766	7:00 a.m. to 7:00 p.m. CST
----------------	----------------------------

Technical Support via E-mail or Fax

If you prefer to seek assistance in writing, please e-mail or fax a detailed description of your problem to the e-mail address or fax number shown below. We recommend using the included customer service form. Enclose any sample printouts that might illustrate the problem.

FAX: (414) 358-6767

E-mail: bradyts@execpc.com

W.H. BRADY CO.

Customer Service Form

This form should be completed in full before requesting technical assistance.

Complete this form before requesting technical assistance.

Serial # _____

Model # _____
(Be specific: include ALL letters and numbers)

Company _____

Address _____

City _____

State, Zip _____

Phone # (_____) _____

Contact _____

Hours available for return call _____

Hardware interface type _____

Unit interfaced with _____

Description of problem, including actions taken just prior to problem occurring:

Product Service and Support Programs

At Brady, our service and support goal is to keep your printer performing optimally. Our service department provides a broad range of service options and are your expert sources for your support and maintenance needs. If you find yourself in need of technical assistance or repair services, our Technical Solutions Center stands ready with answers to any questions you may have.

Appendix F - Permasleeve Printing

First-time operators should refer to chapters 1 and 2 for more in-depth information on printer and sensor positions.

Instructions for One-Sided Permasleeve Printing

Sensor Location

Position the upper media sensor (Phillips head screw) directly over the 0.230 inch x 0.082 inch rectangular registration holes stamped in the Permasleeve carrier. The lower media sensor should remain at its factory-set position, 0.6 inches from the printer fire wall. The Locator may be used to position the upper media sensor more easily and accurately. Refer to, “Transmissive Media Sensor Positioning Using the Locator” in chapter 7.

Note: Make sure the Upper Media Sensor is tightened in place to prevent it from being unintentionally moved as media travels beneath it.

Toggle Setup

Above the printhead is a toggle or cam. This toggle is adjustable in position and pressure. The pressure is controlled by the degree of spring compression found on the toggle. The optimum toggle position is located directly above the center of the sleeves. The optimum pressure can be obtained by adjusting the toggle thumb screws such that a spring height of 0.813 inches for the M-Series printer is obtained.

Printer Function Setup

The recommended burn temperature is 26.

Loading Permasleeve

Load Permasleeve and Brady 4300A or 4300 ribbon as instructed in chapter 2. The Permasleeve roll should be loaded on the spindle such that:

- One-sided Permasleeve: Printable area of sleeves is face-up.
- Two-sided Permasleeve: Permasleeve side not constricted by two strips of adhesive tape is face-up for first-side printing.

Note: Permasleeve must be positioned such that the rectangular registration holes punched in the Permasleeve carrier are to the inside of the printer (towards the fire wall).

Note: Permasleeve may be run directly out of the box through the slot located in the back of the printer, or it can be placed on the media spindle located within the printer. A large roll of Permasleeve should be run directly out of the box to prevent it from rubbing against the printer housing.

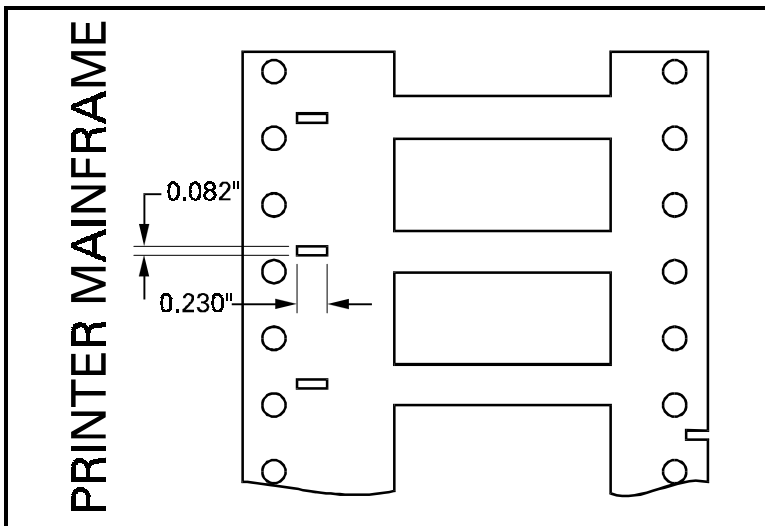

Figure F.2 Permasleeve Positioning

Printer Calibration

Once the media and ribbon are loaded and the media sensor is in place, the printer must be calibrated.

For the M-Series printer, this is accomplished by pressing the MODE Key until the CALIBRATE light is on and then pressing the FEED Key.

Note: Every time a different type or size of media is run (labels or Permasleeve), this Calibration procedure must be repeated.

Verifying Calibration

After the calibration process is completed, make sure the process was successful by pressing the FEED Key repeatedly, verifying that one sleeve is ejected per press of the FEED Key.

Once the calibration process is completed, the media can be rewound by opening the printhead, manually rewinding the material, and closing the printhead. The printer is now in the PAUSE Mode. Press PAUSE to take the printer out of PAUSE Mode. Five inches of material will then feed out. See leader instructions to eliminate this five inches of waste.

Leader Instructions

Whenever the Printhead is opened, the printer goes off-line and the PAUSE light is lit. To put the printer back on-line, press the PAUSE Key. When it is pressed, five inches of media is ejected.

This five inches of waste is avoided on the first print job of every new roll because there is a leader of empty carrier provided. When starting a print job in the middle of the roll, this empty carrier from the front of the roll can be cut off and reattached to the leading edge of the media. This should be reattached using cellophane (transparent) tape. This provides the user with a method of printing without wasting any sleeves.

Printing

Once the material is loaded and the printer is calibrated, a sample sleeve should then be printed to accurately center the printing on the sleeve. Once you have centered the image on the sleeve, the origin does not need to be readjusted again even when changing sides in two-sided printing. If initially the print is not centered on the sleeve, adjust your label format.

The Brady 200M printer is now ready for Permasleeve printing.

Save Settings

To save these settings permanently, press the MODE Key four times.

Instructions for Two-Sided Permasleeve Printing

1. Follow the instructions for One-Sided Permasleeve Printing to print side one.

Note: There should be a five inch leader preceding printed sleeves on side one. This will also serve as a trailer on side two ensuring that all sleeves on side two will be printed. If there is no trailer on side two, the printer will warn the operator that the media is out and will not allow the last five inches of sleeves to print.

2. Cut a five inch piece of empty carrier (leader) from the beginning of the roll and splice it to the front of side two (with cellophane tape) to serve as a leader. You should now have a five inch leader and trailer on the swatch of material.
3. Turn Permasleeve over to print side two. The first sleeve printed on side two should be the last sleeve printed from side one. Brady Labelmark software will automatically invert the order in which a batch is printed.

Example: If sleeve 1 represents the first sleeve ejected from the printer and 001 represents the incremental information printed on the sleeve sent in a batch format, the printing will occur as follows:

Side 1	
Sleeve 1	001
Sleeve 2	002
Sleeve 3	003
Sleeve 4	004
Sleeve 5	005
Side 2 (Side 2 will automatically invert the printing order knowing that sleeve 5 will be the first sleeve printed)	
Sleeve 5	005
Sleeve 4	004
Sleeve 3	003
Sleeve 2	002
Sleeve 1	001

This will ensure that what is printed on Side 1 of the sleeve is the exact same information as what is printed on Side 2.

4. Print side 2 of Permasleeve making sure the first sleeve printed on side two was the last sleeve printed on side one. This will ensure that the information on both sides of the sleeves matches. The final sleeve will print as long as there is five inches of carrier left at the end of the media.

Note: The image will appear in the same spot as side one without any additional adjustments.



INDEX

100/120 VAC Operation, 2-3
220/240 VAC Operation, 2-3
240 VAC Power Cord, A-1
6-Dot/mm Printhead, 9-2

A

Additional System Requirements, 1-3
Adjustments
 Bar Code Darkness, C-1
 Lower Transmissive Media
 Sensor, 7-6
 Media and Ribbon Sensor
 Sensitivity, 7-7
 Printhead Pressure, 7-1
 Upper Transmissive Media
 Sensor, 7-5
ASCII Code Chart, B-1
ASCII Control Codes, 5-3

B

Battery (Lithium)
 Replacement, 3-11
Baud Rate (Setting), 4-2

C

CANCEL Key, 3-4
CANCEL Key Self Test, 3-7
Cleaning
 Exterior Surfaces, 6-1
 Interior, 6-1
 Printhead and Platen Roller, 6-2
 Schedule, 6-1
 Sensors, 6-3
Communications
 Diagnostic Test, 3-10

Communications Capabilities
 Asynchronous Modems, 1-1
 Host Systems, 1-1
Connection Recommendations and
Cautions, 1-4

D

Damage Report, 2-1
Data Bits (Setting), 4-2
Data Signal Levels, 5-5
DCE Devices, 5-4
DTE Devices, 5-4
DTR (Data Terminal Ready), 5-3
DTR/DSR Data Control (Setting), 4-2

E

Electrical Noise, 5-3, 5-5
Error Detection (Setting), 4-2
Extended Printer Diagnostics, 3-11

F

Factory Defaults, 4-4
FCC Rules and Regulations, 1-4
FEED and PAUSE Key Self Test, 3-10
FEED Key, 3-3
FEED Key Self Test, 3-9
FRONT PANEL LIGHTS
 CALIBRATE LIGHT, 3-5
 DARKEN LIGHT, 3-5
 DATA LIGHT, 3-5
 PAPER/RIBBON LIGHT, 3-5
 PAUSE LIGHT, 3-5
 POSITION LIGHT, 3-5
 POWER LIGHT, 3-5
 PRINTHEAD LIGHT, 3-5

I

- Input and Output Signals (Standards Used)
 - EIA RS-232 and CCITT V.24, 5-2
- Inspection, 2-1
- Interface Cables
 - Crossover (Null Modem), 5-4
 - Straight Through, 5-4
- Interface Converter (When Required), 1-2
- Interfaces
 - Parallel, 1-12
 - RS-232, 1-12

L

- Label Available Sensor, 3-3

M

- Media
 - Fanfold, 2-10
 - Loading, 2-7
 - Roll, 2-7
- Media (Types to Use)
 - Card Stock, 1-4
 - Continuous Roll, 1-4
 - Fanfold, 1-4
- Media Sensor Adjustment
 - Lower, 7-6
 - Upper, 7-5
- Media Transport Mechanism, 1-3
- Memory options, 9-2
- MODE Key, 3-4
- Model Designation Label, 1-1

N

- Null Modem, 5-4

O

- Operating Modes
 - Peel-Off, 3-2
 - Rewind, 3-3
 - Tear-Off, 3-2
- Optional Printer Fonts, D-1
- Options
 - 240 VAC Factory Setup, 9-2

P

- Parallel Cabling Requirements, 5-5
- Parallel Interface, 5-5
- Parity (Setting), 4-2
- PAUSE Key, 3-2
- PAUSE Key Self Test, 3-8
- Power (AC)
 - 100/120 Operation, 2-3
 - 220/240 Operation, 2-3
 - Voltage Selection, 2-2
- Premature Head Wear
 - Perforated Media, 1-4
- Print Quality, 1-3
 - Reflectivity and Contrast, 1-3
- Printer Connections
 - RS-232C Internal Connections, 5-4
- Printer Power Up, 2-11
- Printer Self Tests
 - CANCEL Key, 3-7
 - Communications Diagnostics, 3-10
 - FEED Key, 3-9
 - Introduction to, 3-6
 - PAUSE and FEED Keys, 3-10
 - PAUSE Key, 3-8
- Printer Specifications (Complete Listing), 1-6
- Printhead Life
 - Media Abrasion, 1-3
- Printhead Pressure Adjustment, 7-1
- Printhead Wear (Guarding Against Premature), 1-3

Protocol Converter (When Required), 1-2

R

Removing Used Ribbon, 2-11

Repacking the Printer

 Caution Statements, 1-5

Reporting Damage, 2-1

Requirements

 Media and Ribbon, 1-3

Reshipping, 2-1

Ribbon

 Lengths, 1-3

 Widths, 1-3

Ribbon Loading, 2-4

Roll Media

 Peel-Off Mode, 2-9

 Rewind Mode, 2-9

RS-232 Internal Connections, 5-4

RS-232C Pinouts, 5-2

S

Self Tests

 FEED Key and PAUSE Key, 4-4

Serial Communication Port, 5-4

Serial Data Port , 5-2

Shielded Cable (Use of), 1-4

Signal Descriptions

 Parallel Connector, 5-6

Site Requirements, 2-4

Storage, 2-1

System Components, 5-1

System Considerations

 Communications Code (ASCII), 5-1

 Interfaces, 5-1

T

Tear/Peel-Off Bar, 3-2

Toggle Positioning, 7-1

Troubleshooting, 8-1

U

Unpacking, 2-1





W. H. BRADY CO.
® AUTOMATIC IDENTIFICATION PRODUCTS

W. H. Brady Co.

A I P
R

PO

M I

P

FA

W. H. Brady Co.

I C
E E E IUM

P

FA