

DAEWOO

VACUUM CLEANER

RC-350

OWNER'S MANUAL

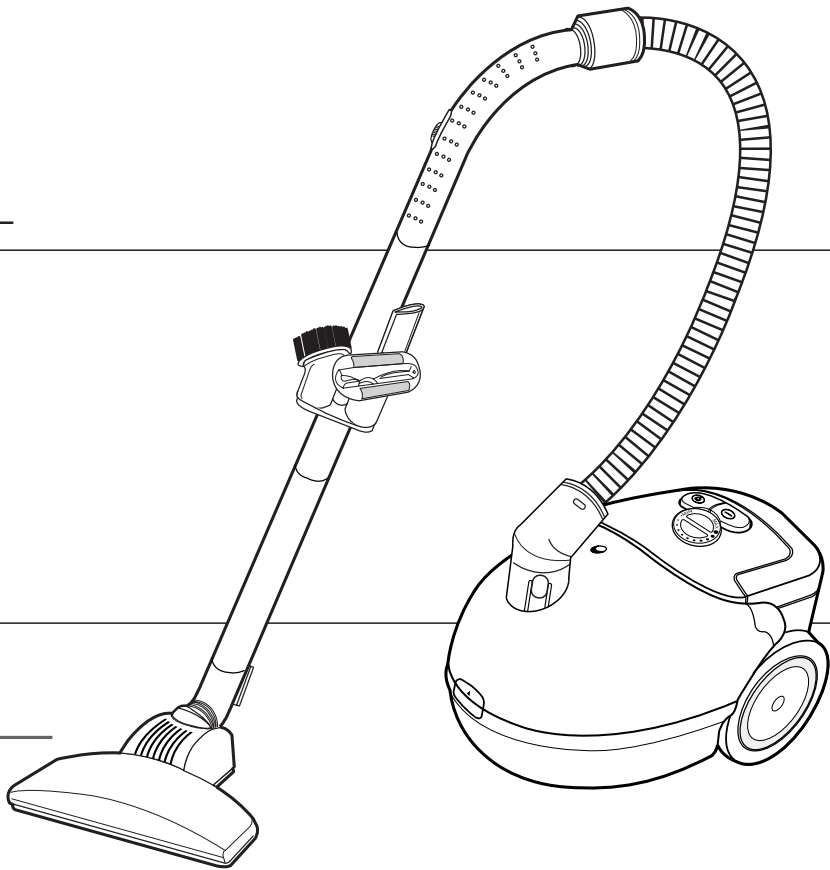
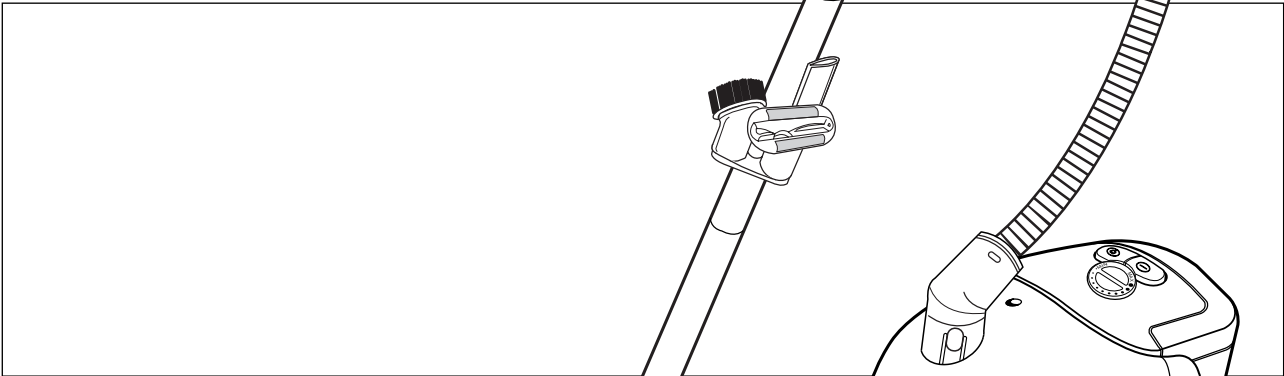

CONTENTS

- Description and operation ...2,3
- Cleaning the filter and Changing the dustbag4
- Precautions for safe use.....5
- Specifications.....6
- Before asking for service6

READ AND KEEP THIS

- i Thank you for purchasing this vacuum cleaner.
- i For proper operation, please read this manual before use.



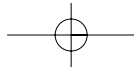

DESCRIPTION AND OPERATION

SUCTION POWER CONTROL

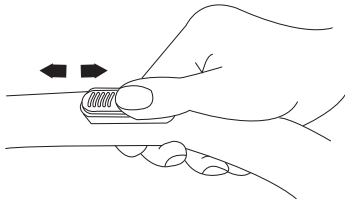

- The suction power control at the hand grip enables you to control suction power.

HOSE CONNECTION

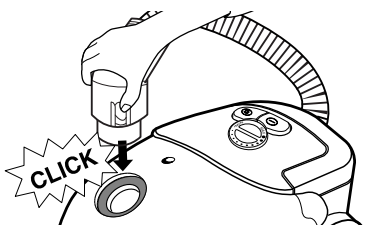
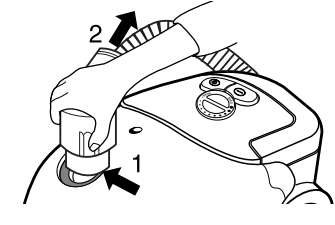

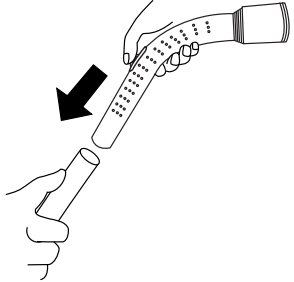

- Connecting the hose : insert the hose firmly into the hose inlet. ("Click")
- Disconnecting the hose: press the button and pull the hose out of the vacuum cleaner.

PIPE CONNECTION



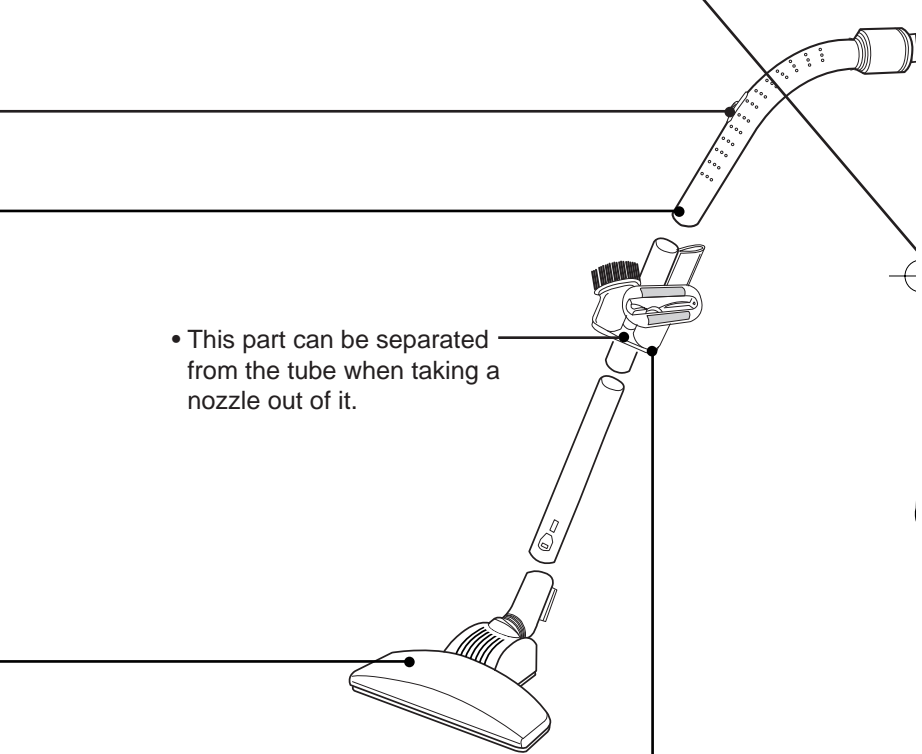

- To Connect the nozzle, hold the tubes and the handle: insert the narrowed section into the wide section.



WIDE SUCTION NOZZLE

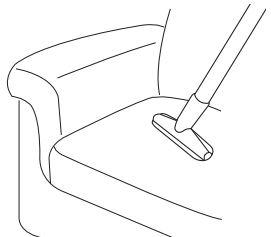
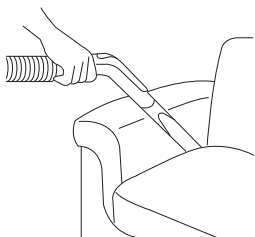

- Use this nozzle for cleaning both carpeted and uncarpeted floors.

UPHOLSTERY NOZZLE	CREVICE NOZZLE	DUS
		

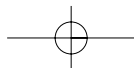

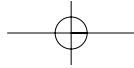

KNOB

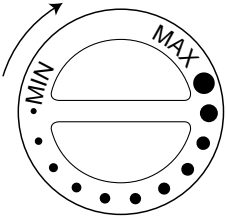

- Power control

ON/OFF SWITCH

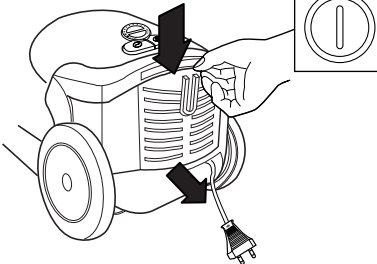

- Press the on/off switch.

CORD REWIND BUTTON

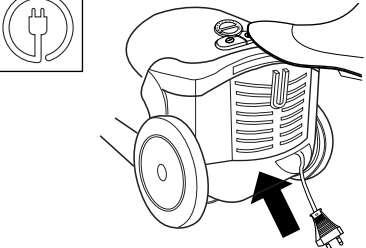

- Rewind the power cord by pressing the cord rewind button.

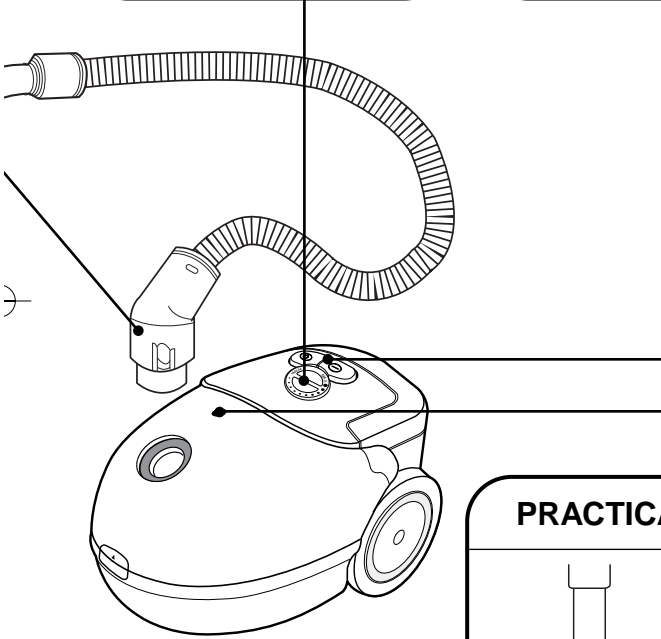

DUST METER

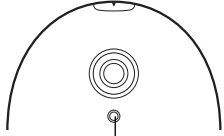

- When the color of the dust meter is changed to RED for long time, change the dust bag.

PRACTICAL PARKING

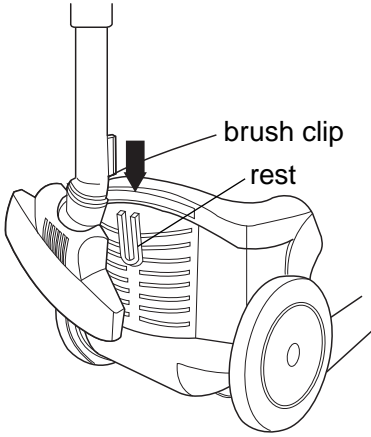

- If you want to stop vacuum cleaning for a while, you can place the brush clip into the rest.

STORAGE

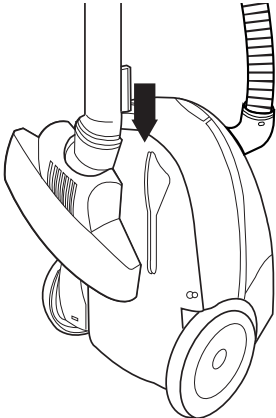

- If you want to store the cleaner, hitch the brush clip onto the vacuum cleaner.

DUSTING BRUSH

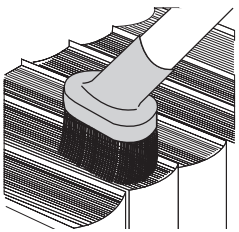
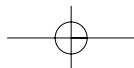

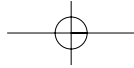
CLEANING THE FILTER

EXHAUST FILTER

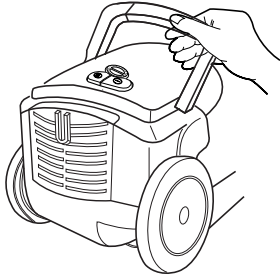

- Switch off and lift the handle.

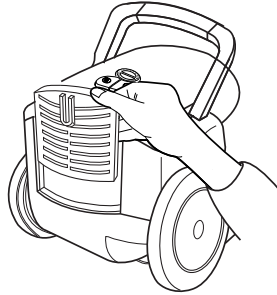

- Pull the filter case upwards from the cleaner.



- Separate the filter from the filter case and shake the dust out of the filter.

MOTOR PROTECTION FILTER

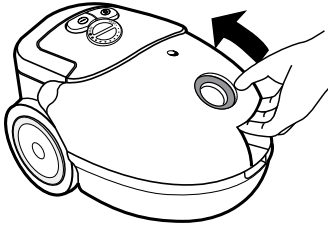

- Switch off and open the cover.

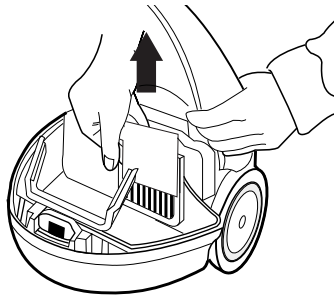

- Hold the cover while taking the filter out of the cleaner.



- Shake the dust out of the filter.

CHANGING THE DUSTBAG

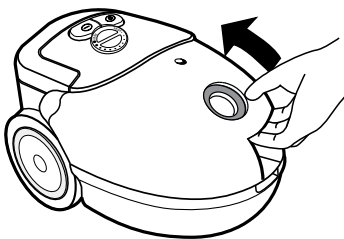

- Switch off and open the cover.

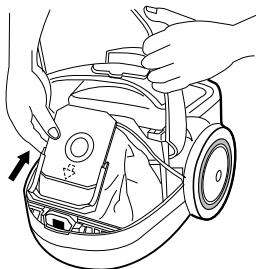

- Hold the cover while separating the dustbag from the dustbag holder.

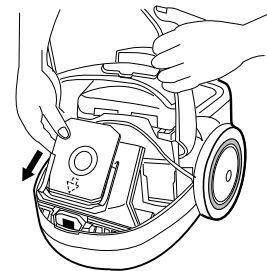

- Insert the new dustbag in the dust bag holder properly as shown in picture.

Note: If no dustbag has been placed into the dustbag holder, the cover cannot be closed.

- If you cannot purchase the RC-300/RC-350 dust bag, Please note you may use the dust bag for the Philips Model No HR6938 OSH.

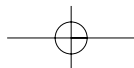

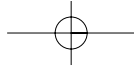

PRECAUTIONS FOR SAFE USE

This vacuum cleaner should only be used for normal dry household dust and dirt.

The manufacturer cannot be responsible for any damage caused by use or operation of the cleaner contrary to these instructions.

If the cleaner is wrongly operated for a purpose other than that for which it is intended, no liability can be accepted for any possible damage.

- Do not vacuum areas which contain moisture or water and inflammable matter, needles, pins, razor blades, matches, cigarette-ends, etc., since they may damage the cleaner or dust bag or make a fire.

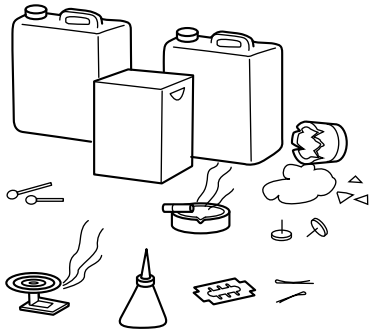

- When rewinding the power cord, hold the plug body before pressing the cord rewind button to prevent whipping.
- Do not pull the power cord out beyond the specified length.

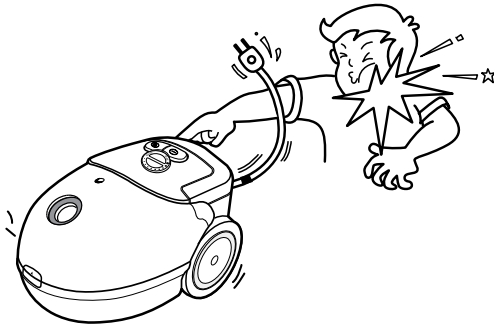

- Make sure a dust bag and a motor protection filter are always inserted.

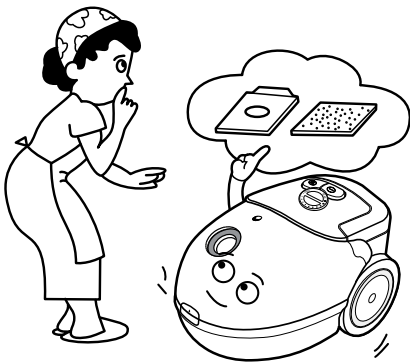

- This product provided with a cable which, if damaged, must be replaced by a repair shop authorized by the manufacturer since special tools are required.

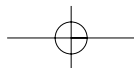
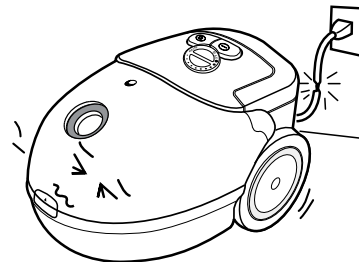

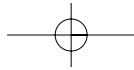

BEFORE ASKING FOR SERVICE

■ Before Asking for Service, please check each item below if you have trouble with your cleaner.

Problem	Check Point	Measure
Suction power is weak.	<ul style="list-style-type: none"> Dust bag Pipe or hose 	If dust bag is dirty, replace it. If clogged or blocked, remove the object.
The cleaner does not work.	<ul style="list-style-type: none"> Power cord ON/OFF switch 	Check if power cord is plugged. Check if the power switch is turned on.
Power cord does not rewind.	<ul style="list-style-type: none"> Power cord 	Pull the power cord out a little and press the cord rewind button.

SPECIFICATIONS

Model	RC-350
Rating	230V/50Hz
Watts	MAX. 1300W(CEE 1100W)
Weights(Net)	5.1kg
Dimension (L X H X D)	354 X 240 X 262mm
Cord Length	6m

• Specifications can be changed for improvement without notice.

