

JVC

DT-V9L3D

INSTRUCTIONS

MULTI FORMAT LCD MONITOR

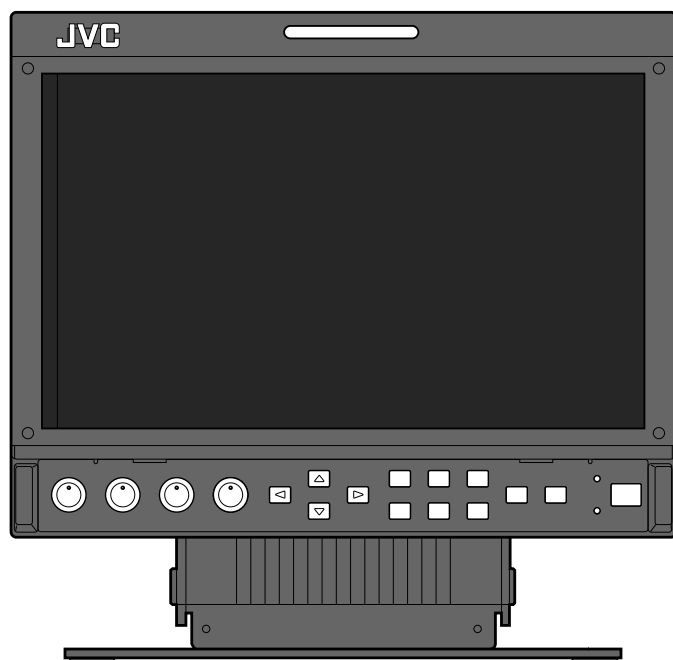

Table of Contents

Safety Precautions	2
IMPORTANT SAFEGUARDS	2
Installation	4
To adjust the stand height	4
Daily Operations / Connections	6
Front panel	6
Rear panel.....	8
Available signals	9
Menu Configuration—MAIN MENU	10
Menu Configuration—SET-UP MENU	14
External Control	16
About the external control	16
Using the MAKE/TRIGGER system	16
Using the RS-232C system	17
Troubleshooting	18
Self-check program	19
Maintenance	20
Specifications	21
General.....	21
Input/output terminals.....	21
Dimensions.....	22

Safety Precautions

WARNING: TO REDUCE RISK OF FIRE OR ELECTRIC SHOCK, DO NOT EXPOSE THIS APPARATUS TO RAIN OR MOISTURE. NO OBJECTS FILLED WITH LIQUIDS, SUCH AS VASES, SHALL BE PLACED ON THE APPARATUS.

IMPORTANT SAFEGUARDS

Electrical energy can perform many useful functions. This unit has been engineered and manufactured to assure your personal safety. But **IMPROPER USE CAN RESULT IN POTENTIAL ELECTRIC SHOCK OR FIRE.** In order not to defeat the safeguards incorporated into this product, observe the following basic rules for its installation, use, and service. Please read these "IMPORTANT SAFEGUARDS" carefully before use.

- All the safety and operating instructions should be read before the product is operated.
- The safety and operating instructions should be retained for future reference.
- All warnings on the product and in the operating instructions should be adhered to.
- All operating instructions should be followed.

POWER CONNECTION

The power supply voltage rating of this product is AC 220 – 240 V.

The power cord attached conforms to the following power supply voltage and countries. Use only the power cord designated to ensure safety and EMC regulations of each country.

- Not all types of power cords are supplied to this product.

For European and Asian countries:
AC 220 – 240 V



For United Kingdom:
AC 220 – 240 V



This plug will fit only into a grounded power outlet. If you are unable to insert the plug into the outlet, contact your electrician to install the proper outlet. Do not defeat the safety purpose of the grounded plug.

- This product should be operated only with the type of power source indicated on the label. If you are not sure of the type of power supply of your home, consult your product dealer or local electric power company.

Note for United Kingdom power cord only

The plug of United Kingdom power cord has a built-in fuse. When replacing the fuse, be sure to use only a correctly rated approved type, re-fit the fuse cover. (Consult your dealer or qualified personnel.)

How to replace the fuse

Open the fuse compartment with the blade screwdriver, and replace the fuse.

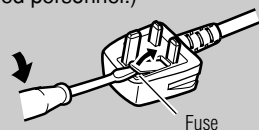

Warning: This is a class A product. In a domestic environment this product may cause radio interference in which case the user may be required to take adequate measures.

- Before connecting other products such as VCR's and personal computers, you should turn off the power of this product for protection against electric shock.
- Do not use attachments not recommended by the manufacturer as they may be hazardous.
- **When replacement parts are required**, be sure the service technician has used replacement parts specified by the manufacturer or equivalents. Unauthorized substitutions may result in fire, electric shock, or other hazards.
- **Upon completion of any service or repairs to this product**, ask the service technician to perform safety checks to determine that the product is in proper operating condition.

The rating label is on the bottom of the monitor.

Under the following conditions,

1. Turn off the power.
 2. Unplug this product from the wall outlet.
 3. Refer service to qualified service personnel.
- a) When the product emits smoke or unusual smell.
 - b) When the product exhibits a distinct change in performance—for example, no picture or no sound.
 - c) If liquid has been spilled, or objects have fallen on the product.
 - d) If the product has been exposed to rain or water.
 - e) If the product has been dropped or damaged in any way.
 - f) When the power supply cord or plug is damaged.

- Do not install this product in the following places:
 - in a damp or dusty room
 - where the product is exposed to soot or steam, such as near the cooking counter or a humidifier
 - near heat sources
 - where condensation easily occurs, such as near the window
- Do not place this product on an unstable cart, stand, or table. The product may fall, causing serious injury to a child or adult, and serious damage to the product.

The product should be mounted according to the manufacturer's instructions, and should use a mount recommended by the manufacturer.

- Do not use this product near water.
- Be sure to install the product in the place where proper temperature and humidity are kept (see "Operating conditions" on page 21). This product becomes hot during its use. Take enough care when handling the product.

Do not attempt to service this product yourself, as opening or removing covers may expose you to dangerous voltages and other hazards. Refer all service to qualified service personnel.

Do not use the product for a long time if the sound is distorted.

- Use only the power source specified on the unit.
- AC power: 220 – 240 V, 50 Hz/60 Hz
 - DC power: 12 – 17 V

- The AC power supply is controlled by turning on/off the POWER switch on the rear panel. If the product is installed in a place where you cannot easily turn on/off the POWER switch, control the AC power supply by plugging/unplugging the power cord into/from the AC outlet. In this case, install the product as close to the AC outlet as possible, and leave enough space for plugging/unplugging the power cord. If the product is installed in a place where you cannot easily plug/unplug the power cord, equip an easily accessible device to the wiring of the building for turning on/off the power.
- When the product is left unattended and unused for a long period of time, unplug it from the wall outlet and disconnect the cable system.
- Do not overload wall outlets, extension cords, or convenience receptacles on other equipment as this can result in a risk of fire or electric shock.
- Use only the accessory cord designed for this product to prevent shock.

- Slots and openings in the cabinet are provided for ventilation. These ensure reliable operation of the product and protect it from overheating. These openings must not be blocked or covered.
- Never push objects of any kind into this product through openings as they may touch dangerous voltage points or short-circuit the parts, which could result in a fire or electric shock.
- Never spill liquid of any kind on the product.
- Never place anything on the product. (Placing liquids, naked flames, cloths, paper, etc. on the product may cause a fire.)
- Do not apply any strong shock to the LCD panel. (Do not hit any object against it or push it with a sharp-pointed tool.)
- Do not put heavy objects on the product.
- Do not step on or hang on the product.

Caution for use of the product in the high temperature

Do not use the product in places of high temperature; otherwise, parts of this product or the LCD panel may be damaged. This product is equipped with a temperature sensor to give warning if the temperature becomes too high. If the temperature exceeds the range of normal use, "TEMP. OVER" is displayed, and the power is turned off automatically if the temperature becomes any higher. In this case, move the product to a place of low temperature to let it cool down.

WARNING: TO PREVENT FIRE OR SHOCK HAZARDS, DO NOT EXPOSE THIS APPARATUS TO RAIN OR MOISTURE.

WARNING: THIS APPARATUS MUST BE CONNECTED TO A MAINS SOCKET OUTLET WITH A PROTECTIVE EARTHING CONNECTION.

CAUTION: DANGER OF EXPLOSION IF BATTERY IS INCORRECTLY REPLACED. REPLACE ONLY WITH THE SAME OR EQUIVALENT TYPE.

Dear Customer,

This apparatus is in conformance with the valid European directives and standards regarding electromagnetic compatibility and electrical safety.

European representative of Victor Company of Japan, Limited is:
JVC Technical Services Europe GmbH
Postfach 10 05 04
61145 Friedberg
Germany

Information for Users on Disposal of Old Equipment

[European Union]



This symbol indicates that the electrical and electronic equipment should not be disposed as general household waste at its end-of-life. Instead, the product should be handed over to the applicable collection point for the recycling of electrical and electronic equipment for proper treatment, recovery and recycling in accordance with your national legislation.

By disposing of this product correctly, you will help to conserve natural resources and will help prevent potential negative effects on the environment and human health which could otherwise be caused by inappropriate waste handling of this product. For more information about collection point and recycling of this product, please contact your local municipal office, your household waste disposal service or the shop where you purchased the product.

Penalties may be applicable for incorrect disposal of this waste, in accordance with national legislation.

Attention:

This symbol is only valid in the European Union.

(Business users)

If you wish to dispose of this product, please visit our web page <http://www.jvc.eu/> to obtain information about the take-back of the product.

[Other Countries outside the European Union]

If you wish to dispose of this product, please do so in accordance with applicable national legislation or other rules in your country for the treatment of old electrical and electronic equipment.

EMC Supplement

This equipment is in conformity with the provisions and protection requirements of the corresponding European Directives. This equipment is designed for professional video appliances and can be used in the following environments:

- Controlled EMC environment (for example purpose built broadcasting or recording studio), and rural outdoors environment (far away from railways, transmitters, overhead power lines, etc.)

In order to keep the best performance and ensure electromagnetic compatibility, we recommend to use cables not exceeding the following length:

Cable	Length
Power cord (attached cable (H05VV-F 3 x 0.75 mm ²))	2.0 m
Video signal cable (coaxial cable)	2.0 m
Audio signal cable (shielded cable)	1.5 m
RS-232C cable (shielded cable) (A straight cable with a D-sub 9-pin connector)	2.0 m
REMOTE cable (twist pair cable) (A straight LAN cable)	2.0 m
Earphone cable (parallel cable)	1.0 m

The inrush current of this apparatus is 9.098 ampere.

CAUTION

In case where the strong electromagnetic waves or magnetism are near the audio cable or the signal cable, the sound or the picture will contain noise. In such cases, please keep the cable away from the sources of the disturbance.

Installation

CAUTION

- Do not rest your arm on the monitor or lean against the monitor.
- Do not touch the LCD panel when installing the monitor.
- Be sure to install the monitor securely to prevent the monitor from falling over, which may cause damage to the monitor or injury.

When shipped from factory, the stand is attached to the monitor.

You can tilt the monitor from about 20° upward to about 10° downward.

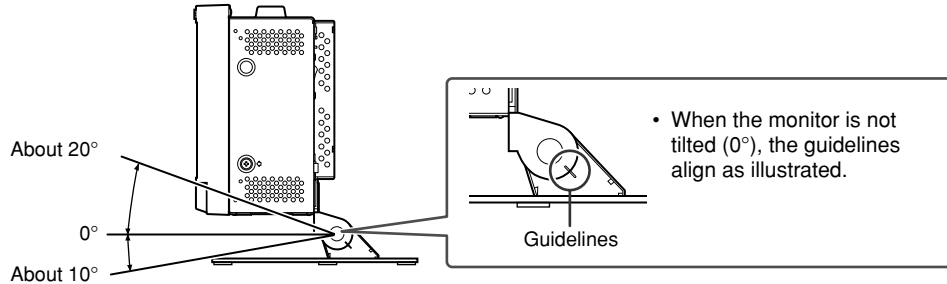

CAUTION

- Be careful not to pinch your fingers in the gap between the monitor and the stand.
- When the stand is attached to the lower position (see page 5), you cannot tilt the monitor downward.

■ To adjust the stand height

You can select the stand height according to your preference—higher position or lower position. To change the stand height, change the position of the screw hole used for attaching the stand.

- When shipped from factory, the stand is attached to the higher position.
- Before adjusting the stand height, set the monitor angle to 0°.

CAUTION

- Lay the monitor on a cloth with the LCD panel facing down to prevent the LCD panel from being damaged.
- Depending on the type of external batteries, the stand cannot be attached or detached when the external battery is attached on the monitor.
- When the stand is attached on the lower position, some types of external batteries cannot be attached to the monitor.

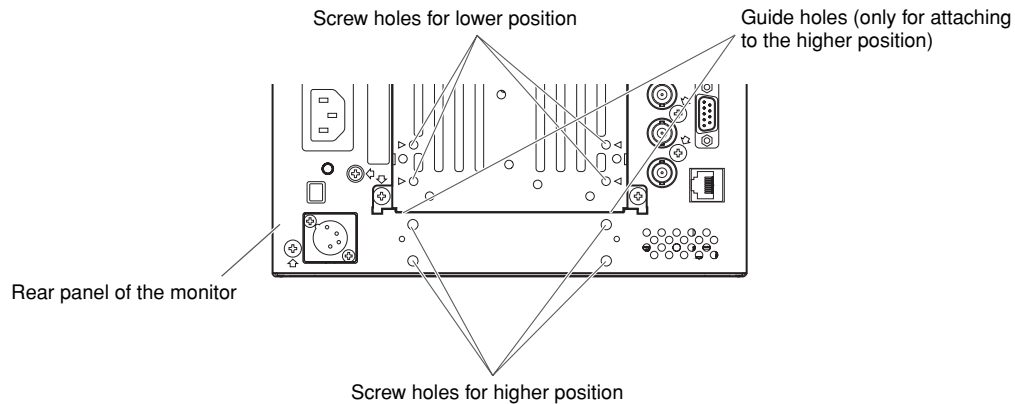

Higher position

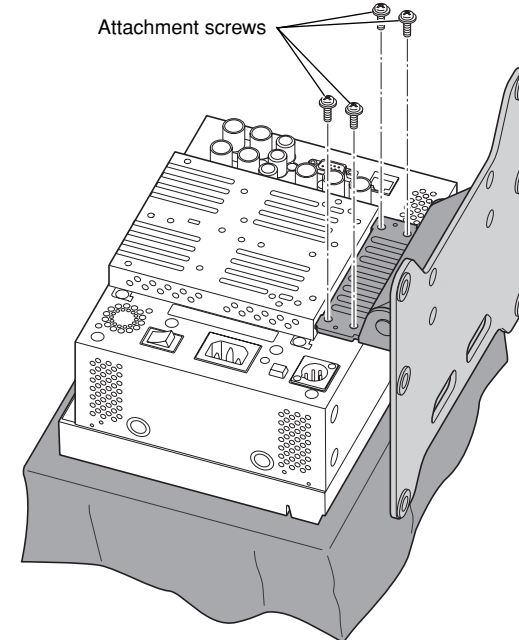
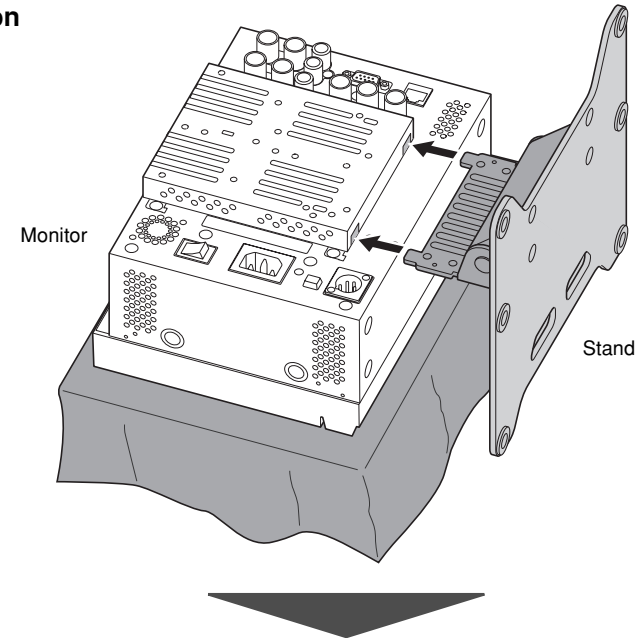

Lower position

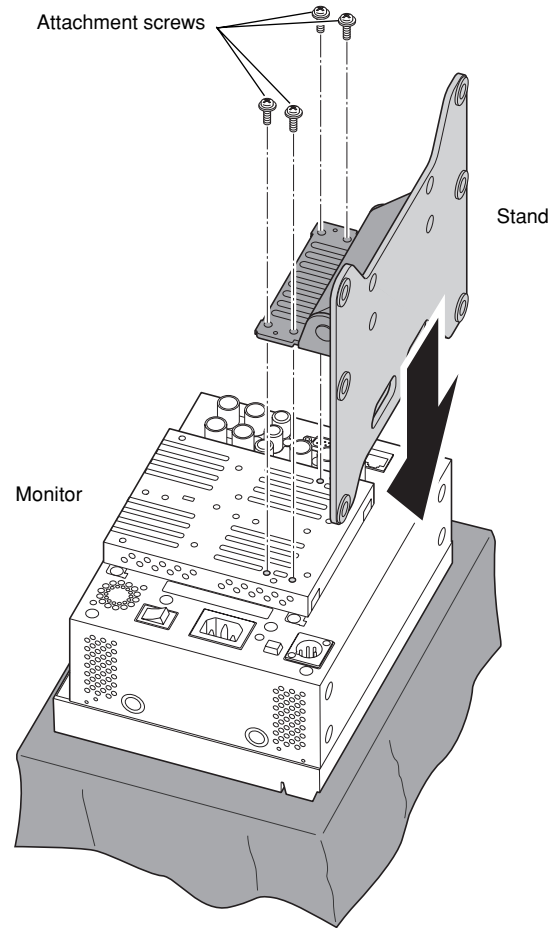

To prevent an accidental fall

Fix the monitor to a wall by using strings.

Fixing the monitor

Attach the hook (not provided) to the VESA mounting holes on the rear panel (use the two 100 mm pitch holes on the upper side) using M4 x 10 mm screws (not provided). Bind the hooks on the rear panel of the monitor to a wall or a pillar using durable string.

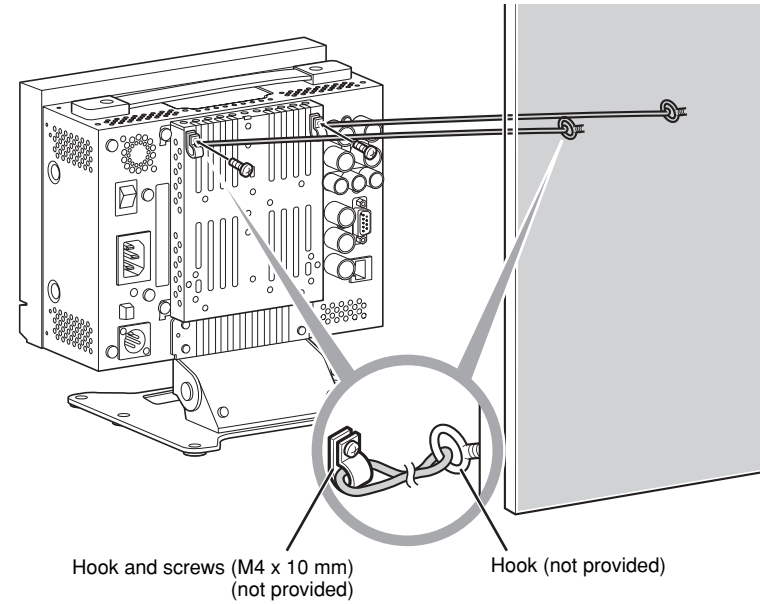

■ Front panel

Tally lamp

This lamp is controlled by the tally function of the MAKE/TRIGGER terminal.

- This lamp can also be used as the format indicator (☞ “FORMAT INDICATOR” in “FUNCTION SETTING” on page 14).

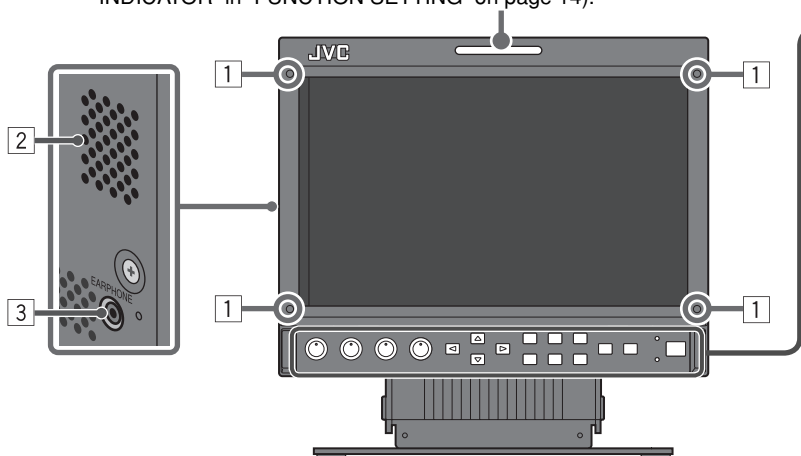

1 Screw holes for attaching protective filter (provided)

- Attach the protective filter by using the provided screws.
- Attach the filter to the LCD panel with the frosted side of the filter facing outwards (when shipped from the factory, a protective film and a sticker are attached to the frosted side).

CAUTION

- Use only the provided screws to avoid damaging the monitor.
- When attaching the protective filter, do not fasten screws too tightly; otherwise, the protective filter may be damaged.

2 Speaker (monaural)

The speaker emits the same audio signal as emitted from the AUDIO (MONITOR OUT) OUT 1 terminal. (☞ “9 AUDIO (MONITOR OUT) terminals” on page 8)

3 EARPHONE (earphones) jack (monaural)

Connect earphones to this jack to listen to the same sound as produced from the speaker.

4 Picture adjustment knob

PHASE: Adjusts the picture hue.

CHROMA: Adjusts the picture color density.

BRIGHT: Adjusts the picture brightness.

CONTRAST: Adjusts the picture contrast.

5 MUTING button

Turns off the sound when no menu screen is displayed.

- To cancel the function, press the button again or press VOL. +/- buttons.

6 ◀/▶/△/▽ buttons

When a menu screen is displayed

Selects or adjusts menu items. (☞ “Menu Operations” on page 7)

When no menu screen is displayed

Selects the audio channels of EMBEDDED AUDIO signals, or adjusts the volume. (☞ “Audio Channel Selection” on page 7)

- Pressing ◀ button while holding ▽ button displays the SET-UP MENU. (☞ “Menu Operations” on page 7)

7 SCR. CHK. (Screens check) button/lamp

Displays only the selected element (R, G, B, or the luminance) of video signal.

- Each time you press this button, the screen changes in the following order.

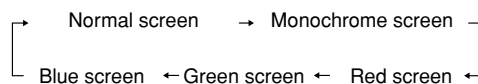

- “NO EFFECT” is displayed when you press a button which is not available for the current input or signal format (the lamp lights even when the function does not actually work).
- The items controlled by the MAKE system cannot be controlled by the buttons on the front panel (“REMOTE ON” is displayed and the lamps do not light).

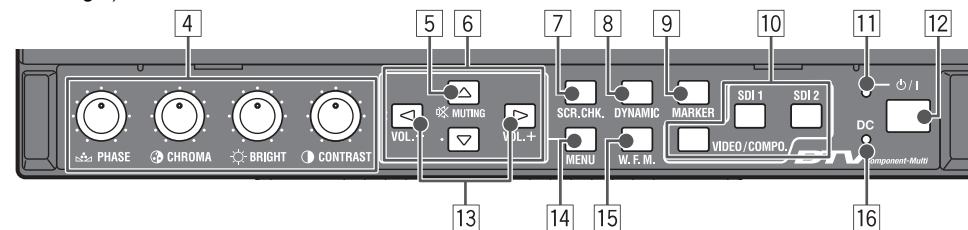

8 DYNAMIC button/lamp

Adjusts the picture to be suitable for a bright place.

- When the DYNAMIC lamp lights:
 - “BACK LIGHT” and “PICTURE SUB ADJ.” are not displayed on the menu.
 - The setting of “BACK LIGHT” is ineffective. (☞ page 10, 14)

9 MARKER button/lamp

Displays/hides the area marker and the safety marker.

- Select the size and the style of the markers in “MARKER” of the MAIN MENU (☞ page 11).
- The marker is not displayed when it is set to “OFF” in “MARKER.” (☞ “NOTE” on page 11)

10 Input select buttons/lamps

Selects an input.

VIDEO/COMPO.: VIDEO/COMPONENT terminal

SDI 1: E. AUDIO HD/SD SDI (IN 1) terminal

SDI 2: E. AUDIO HD/SD SDI (IN 2) terminal

- The lamp for the selected input lights.
- Select an appropriate setting of “VIDEO/COMPO. SEL.” (☞ page 10).

11 Power lamp

Unlit: The monitor is completely off (both the POWER switch and DC switch on the rear panel are turned off).

Lights in green: The monitor is on.

Lights in orange: The monitor is off (on standby).

Flashes in orange: The monitor is in the P. SAVE (power save) mode (☞ “NO SYNC ACTION” in “SYNC FUNCTION” on page 13).

12 ⏻ / | button

Turns on and off (on standby) the monitor.

- The power switches (the POWER switch and DC switch) are equipped on the rear panel of the monitor (☞ 1, 3 on page 8).
- To turn off the monitor completely, turn off the POWER switch and DC switch.

13 VOL. +/- buttons

Adjusts the volume.

14 MENU button

Activates/deactivates the display of the MAIN MENU. (☞ “Menu Operations” on page 7)

15 W. F. M. (Wave form monitor) button/lamp

Displays/hides the indication of the wave form monitor.

- Adjust the settings of the wave form monitor in “WAVE FORM SETTING” of the MAIN MENU (☞ page 8).

16 DC lamp

When the DC 12 V power voltage is being lowered due to the battery consumption, the lamp changes to orange from green. When the voltage becomes lower than a certain level, the monitor automatically turns off and the lamp turns to red.

- Make sure to turn off the POWER switch and DC switch on the rear panel before replacing the battery.
- The length of time that the lamp lights in orange differs depending on the type of battery or the battery condition. It is recommended to replace the battery when the lamp turns to orange.

Menu Operations

1 Display the menu.

To display the **MAIN MENU**

➔ Press MENU button.

To display the **SET-UP MENU**

➔ Press ◀ button while holding ▽ button.

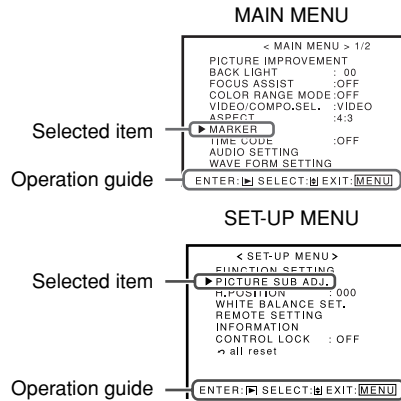

2 Press △ ▽ buttons to select an item, then press ▷ button.

- For some items, adjustments will be made by pressing ◀▷.

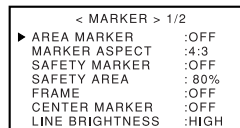

Ex.: When "MARKER" in the MAIN MENU is selected

3 Press △ ▽ buttons to select an item, then press ◀▷ buttons to make adjustments.

4 Press MENU button to finish the menu operation.

- Pressing MENU button repeatedly deactivates the display of the menu.

Audio Channel Selection

Select audio channels emitted from the speaker and the AUDIO (MONITOR OUT) OUT1/OUT2 terminals, when EMBEDDED AUDIO signals come in to the E. AUDIO HD/SD SDI terminal (IN1 or IN2) and SDI input (1 or 2) is selected.

- The speaker emits the same audio signal emitted from the AUDIO (MONITOR OUT) OUT 1 terminal.
- The setting is memorized for each input (SDI 1 and SDI 2).

1 Press ◀ or ▷ button when a menu is not displayed.

The screen for audio channel selection is displayed.

- The screen for audio channel selection automatically disappears in about 30 seconds after the previous operation.

Audio channel selection screen

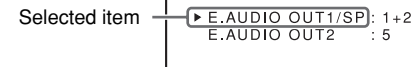

2 Press △ ▽ buttons to select the channel to set.

- E.AUDIO OUT1/SP:
AUDIO (MONITOR OUT) OUT1 terminal and the speaker.
- E.AUDIO OUT2:
AUDIO (MONITOR OUT) OUT2 terminal.

3 Press ◀▷ buttons to select an audio channel.

Each time you press the button, the audio channel changes as follows:
1/2/3/4/5/6/7/8/9/10/11/12/1+2/3+4/5+6/7+8/
9+10/11+12/1G(1-4)/2G(5-8)/3G(9-12)/
1G+2G(1-8)/1-3G(1-12)

4 Press MENU button.

The screen for audio channel selection disappears.

On the Information Display

The monitor displays the information below depending on the settings of the menu.

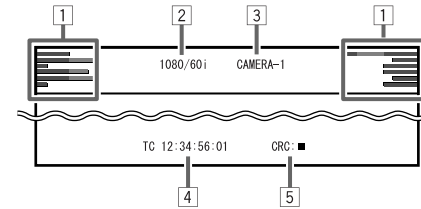

1 Audio level meter

- Not displayed when no signal comes in for the SDI inputs or "LEVEL METER ch" is set to "OFF."

☞ "AUDIO SETTING" and "NOTE" on page 12

2 Signal format

- Displayed when "STATUS DISPLAY" is set to "ON." (☞ "INFORMATION" on page 15)
- For the contents displayed, see "On the signal format" below and "Available signals" on page 9.

3 Source name assigned in "CHARACTER SET."

- Displayed when "SOURCE ID" is set to "ON."
- Displayed in large letters when "STATUS DISPLAY" is set to "OFF" or "AUTO."

☞ "INFORMATION" on page 15

4 Time code

- Displayed when "TIME CODE" is set to "ON." (☞ "TIME CODE" on page 11)
- When the input signal includes no time code, "TC --:--:--:--" is displayed.

5 CRC error indication

- Displayed when "CRC ERROR" is set to "ON." (☞ "INFORMATION" on page 15)
- A red square is displayed when an error occurs.

On the Status Display

If you press the input button of the current input, the status of the input signal and setting of muting are displayed for about 3 seconds.

- Make the setting to display/hide the status in "STATUS DISPLAY" of the "INFORMATION" (☞ page 15).
- When "STATUS DISPLAY" is set to "AUTO" or "ON," the status below is also displayed in the following cases:
 - When you change the input
 - When the signal condition of the current input changes
 - When you turn on the monitor
- When "STATUS DISPLAY" is set to "ON," the signal format will remain displayed 3 seconds after the status is displayed.

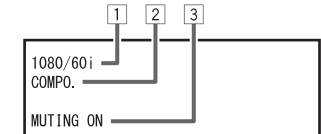

1 Signal format

- For the contents displayed, see "On the signal format" below and "Available signals" on page 9.

2 Setting of "VIDEO/COMPO. SEL."

☞ page 10

3 Setting of "MUTING"

- Displayed only when muting is activated.
- ☞ "[5] MUTING button" on page 6

On the signal format

The following messages appear depending on the type of input signals and their conditions.

When no video signal comes in

➔ "NO SYNC"

When a noncompliant video signal comes in

➔ "Out of range"

When "COLOR SYSTEM" (☞ "FUNCTION SETTING" on page 14) is set to "AUTO" and the noncompliant composite video signals come in

➔ "OTHERS"

Rear panel

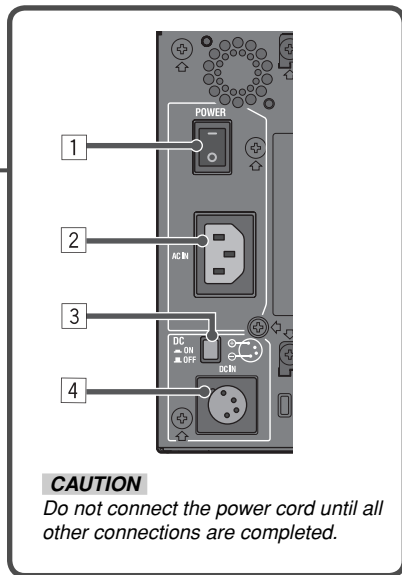
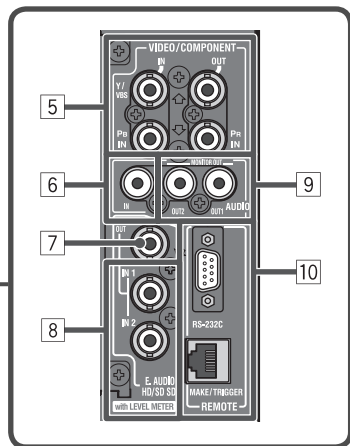
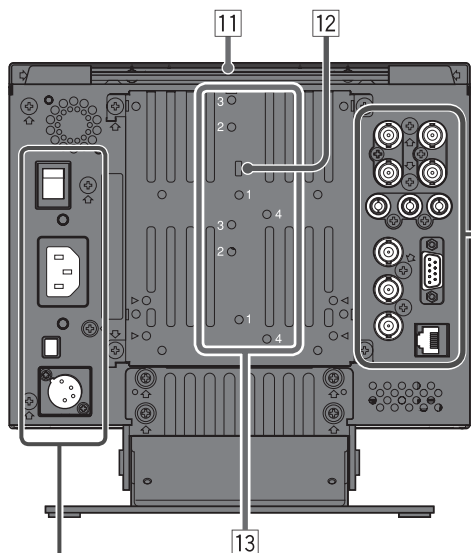

CAUTION

Do not connect the power cord until all other connections are completed.

When using DC 12 V power (maximum DC 17 V), check the DC IN terminal pin signal, and use the correct polarity. If the polarity is reversed, this could cause a fire or personal injury.

1 POWER switch

Turns AC power on or off.
 • You need to press / button (☞ 12 on page 6) to use the monitor after turning on the POWER switch.

2 AC IN terminal

AC power input connector.
 Connect the provided AC power cord to an AC outlet.
 • Attach the provided power cord holder to prevent accidental disconnection of the AC power cord (☞ “Attaching the Power Cord Holder” on page 9).

3 DC switch

Turns the DC 12 V power on or off.
 • You need to press / button (☞ 12 on page 6) on the front panel to turn on the monitor after turning on the DC switch.
 • The monitor consumes the battery even while the monitor is on standby. To save battery life, turn off the DC switch.

4 DC IN terminal

DC 12 V (maximum DC 17 V) power input connector.
 • While using both the AC and DC 12 V power supply, AC power supply is preferentially used. If the AC power supply is cut off (for example, when turning off the POWER switch), the power supply automatically switches to the DC 12 V power supply.

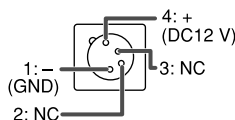

5 VIDEO/COMPONENT terminals (BNC)

IN: Input terminals for the composite (VBS) and the analog component (Y/P_B/P_R) signals.

- Select the signal type in “VIDEO/COMPO. SEL.” corresponding to the type of the input signal (☞ page 10).

OUT: Output terminal for the composite (VBS) and the analog component (Y) signals.

6 AUDIO IN terminal (pin jack)

Input terminal for the analog audio signals.
 • Use this terminal for the analog audio connection of the SDI.

7 E. AUDIO HD/SD SDI (SWITCHED OUT) terminal (BNC)

Output terminal for the HD/SD SDI signals.
 • The SDI signals of the current input (SDI 1 or SDI 2) are re-clocked, then emitted.
 • When an input other than SDI 1 and SDI 2 is selected, the SDI signal of the input selected last time is emitted from this terminal.
 • The signals are emitted from this terminal only when the monitor is on or in “P.SAVE” (power save) mode.

8 E. AUDIO HD/SD SDI (IN 1, IN 2) terminals (BNC)

Input terminals for the HD/SD SDI signals.
 • The terminals accept also EMBEDDED AUDIO signals including up to 12 audio channels with a sampling frequency of 48 kHz.

9 AUDIO (MONITOR OUT) terminals (pin jack)

Output terminals for the analog audio signal.
 • The terminals emit the audio signals coming in from the AUDIO IN terminal or EMBEDDED AUDIO signals coming in from the E. AUDIO HD/SD SDI (IN 1 or IN 2) input terminal. (☞ “Audio Channel Selection” on page 7)
 • The signal is output from these terminals only when the monitor is on or in “P.SAVE” (power save) mode. (☞ “NO SYNC ACTION” in “SYNC FUNCTION” on page 13)
 • The EMBEDDED AUDIO signal...
 – is decoded into an analog signal, then emitted.
 – is emitted only when “SDI 1” or “SDI 2” is selected, and when EMBEDDED AUDIO signals come in to the E. AUDIO HD/SD SDI (IN 1 or IN 2) terminal.

10 REMOTE terminals

Terminals for controlling the monitor by an external control. (☞ “External Control” on page 16)

11 Carry handle

Use this handle when carrying the monitor.

12 Security slot

Attach a security wire to this slot.

13 Screw holes for external battery attachment

Attach external battery for DC 12 V power supply by using 2 screw holes. Choose the appropriate screw holes from 1, 2, 3 or 4, according to the type of external battery.
 • Use the Anton Bauer Dionic 90 (mount: QR DXC-M3A) external battery.

CAUTION

- Do not use the external battery for DC 24 V power supply.
- Use only the battery specified above. If a heavy battery is used, it may fall off depending on the way the monitor is used.

Note for connections

- Before making any connections, turn off all the equipment.
- Use a cord whose plugs correctly match the terminals on this monitor and the equipment.
- Plugs should be firmly inserted; poor connections could cause noise.
- When unplugging a cord, be sure to grasp its plug and pull it out.
- DO NOT connect the power cord until all connections are complete.
- Refer also to the user manual of each piece of equipment.

■ Available signals

The following signals are available for this monitor.

Video signals

No.	Signal name	Signal format shown in the status display (see page 7)	Input terminal		E. AUDIO HD/ SD SDI*1
			VIDEO/COMPONENT		
			VBS (Composite)	Y/Pb/Pr (Analog component)	
1	NTSC*2	NTSC	√	—	—
2	PAL	PAL	√	—	—
3	B/W50	PAL	√	—	—
4	B/W60*2	NTSC	√	—	—
5	480/60i	480/60i	—	√	—
6	480/59.94i*2	480/59.94i	—	√	√
7	576/50i	576/50i	—	√	√
8	480/60p	480/60p	—	√	—
9	480/59.94p	480/59.94p	—	√	—
10	576/50p	576/50p	—	√	—
11	720/60p	720/60p	—	√	√
12	720/59.94p	720/59.94p	—	√	√
13	720/50p	720/50p	—	√	√
14	1080/60i	1080/60i	—	√	√
15	1080/59.94i	1080/59.94i	—	√	√
16	1035/60i	1080/60i	—	√*3	√*3
17	1035/59.94i	1080/59.94i	—	√*4	√*4
18	1080/50i	1080/50i	—	√	√
19	1080/30psF	1080/60i	—	√*3	√*3
20	1080/25psF	1080/50i	—	√*5	√*5
21	1080/29.97psF	1080/59.94i	—	√*4	√*4
22	1080/24psF	1080/24psf	—	√	√
23	1080/23.98psF	1080/23.98psf	—	√	√

√: Acceptable

—: Not acceptable

*1 Compatible with EMBEDDED AUDIO signals

*2 When the number of vertical scanning lines of the incoming signal is 483, the picture is displayed with 480 lines.

*3 The signal is recognized as 1080/60i.

*4 The signal is recognized as 1080/59.94i.

*5 The signal is recognized as 1080/50i.

- Analog component signals are compatible with Y on sync signals.

Attaching the Power Cord Holder

The provided power cord holder prevents accidental disconnection of the AC power cord from the AC IN terminal.

- The power cord holder consists of two parts, a case and a cover.

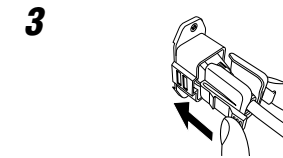
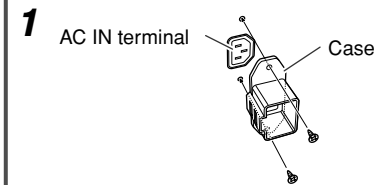

CAUTION

Use only the provided screws.

CAUTION

Make sure the plug will not be pulled out after the cover is attached to the case.

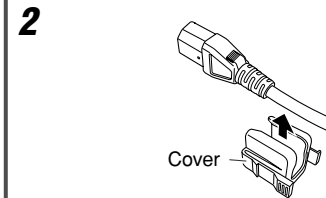

To detach the cover

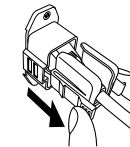

For the operation procedure, see page 7.

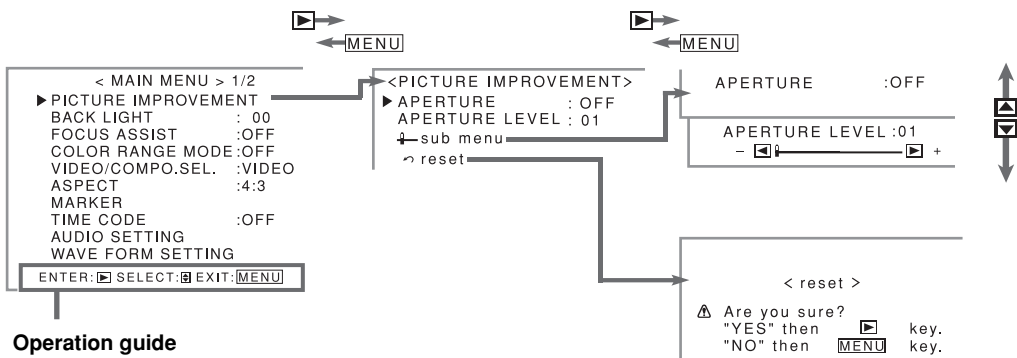

Operation guide
Shows the buttons for each operation.

- The menu automatically disappears in about 30 seconds after the previous operation.
- Some items may not appear on the menu depending on the input or the input signal.
- The items controlled by the MAKE system do not appear on the menu.

PICTURE IMPROVEMENT

Setting for the picture quality

Item	To do	Setting value
APERTURE*	Select the frequency of the luminance signal compensated in "APERTURE LEVEL."	OFF, LOW, HIGH
APERTURE LEVEL*	Compensate the frequency response of the luminance signal of the video signal.	01 – 10
sub menu	Display the sub menu which enables you to adjust the items of "PICTURE IMPROVEMENT" while viewing the actual picture.	
reset	Restore the default settings for all the items in "PICTURE IMPROVEMENT."	

BACK LIGHT Setting value: -20 – +20

Adjusts the brightness of the display.

- When the DYNAMIC lamp lights, this item does not appear on the menu (☞ 8 on page 6).

FOCUS ASSIST Setting value: OFF, ON

Helps to focus the picture.

- When "ON" is selected,
 - "PICTURE IMPROVEMENT" is not displayed on the menu.
 - The settings of "PICTURE IMPROVEMENT" are ineffective.

COLOR RANGE MODE Setting value: OFF, ON

Reduces the difference of the luminance level specific to the LCD panel.

- When "ON" is selected, the color temperature becomes the innate temperature in the LCD panel, and the setting of "WHITE BALANCE SET." becomes ineffective (☞ page 14).

VIDEO/COMPO. SEL. Setting value: VIDEO, COMPO. (component)

Selects the signal type you want to use for the VIDEO/COMPONENT terminals.

- When select the component (COMPO.), make sure to set the component level in "COMPO. LEVEL" in "PICTURE SUB ADJ." (☞ page 14).

ASPECT* Setting value: 4:3, 16:9

Changes the aspect ratio of the picture.

* Memorized for each input — composite signal input (VIDEO), component signal input (COMPO.), SDI 1 and SDI 2.

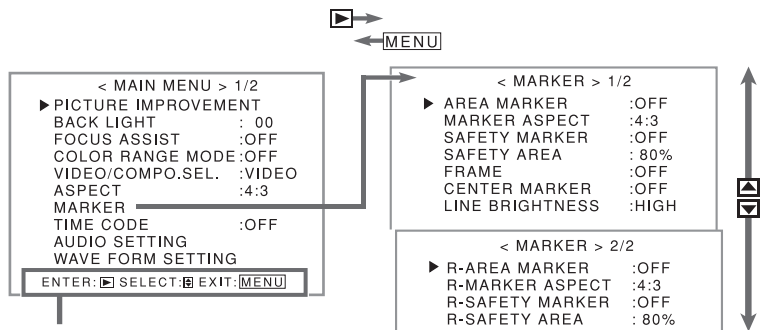

Operation guide
Shows the buttons for each operation.

- The menu automatically disappears in about 30 seconds after the previous operation.
- Some items may not appear on the menu depending on the input or the input signal.
- The items controlled by the MAKE system do not appear on the menu.

NOTE

Setting of “AREA MARKER”, “SAFETY MARKER”, “R-AREA MARKER”, “R-SAFETY MARKER”

The setting values and features are as follows.

- OFF:** Deactivate the marker.
- LINE:** Displays the area with an outline.
- HALF:** The area outside the specified aspect ratio of the screen is displayed at 50% transparency.
- HALF+L:** The area of the specified aspect ratio of the screen is indicated by an outline, and the area outside of that is displayed at 50% transparency.
- BLK.:** The area outside the specified aspect ratio of the screen is black. Only the portion of the picture within the designated area is displayed.
- BLK. +L:** The area of the specified aspect ratio of the screen is indicated by an outline, and the area outside of that becomes black so that only the area inside the line is displayed.

MARKER*1

Settings for marker functions

1/2

Item	To do	Setting value
AREA MARKER*2	Activate/deactivate the area marker and select the style of it.	☞ “NOTE”
MARKER ASPECT*2	Select the aspect ratio of the area marker.	4:3, 14:9, 13:9, 2.35:1, 1.85:1, 1.66:1
SAFETY MARKER	Activate/deactivate the safety marker and select the style of it.	☞ “NOTE”
SAFETY AREA	Adjust the area of the safety marker.	80% – 100%
FRAME*3	Displays/hides the frame indicating the area of the specified aspect ratio.	OFF, ON
CENTER MARKER	Displays/hides the marker indicating the center position of the picture.	OFF, ON
LINE BRIGHTNESS	Adjust the brightness of the marker.	HIGH, LOW

2/2

Item	To do	Setting value
R-AREA MARKER*2	Activate/deactivate the area marker and select the style of it.	☞ “NOTE”
R-MARKER ASPECT*2	Select the aspect ratio of the area marker.	4:3, 14:9, 13:9, 2.35:1, 1.85:1, 1.66:1
R-SAFETY MARKER	Activate/deactivate the safety marker and select the style of it.	☞ “NOTE”
R-SAFETY AREA	Adjust the area of the safety marker.	80% – 100%

- The area marker and the safety marker is displayed by using MARKER button or external control.
- Select either non-“R-” items or “R-” items to activate by using external control (☞ “External Control” on page 16).
- When a picture is displayed in 4:3 aspect ratio, the safety marker for the 4:3 area is displayed.
- To display the safety marker for the area of a picture displayed in 16:9 aspect ratio, hide the area marker. (☞ “NOTE”)

*1 Memorized for each input — composite signal input (VIDEO), component signal input (COMPO.), SDI 1 and SDI 2.

*2 Displayed only when picture is displayed in 16:9 aspect ratio.

*3 For signals of NTSC, B/W60, 480/60i and 480/59.94i, only the vertical borders of the frame are displayed.

TIME CODE Setting value: OFF, ON

Activates/deactivates the display of the time data (time code) contained in the SDI signal.

(☞ “On the Information Display” on page 7)

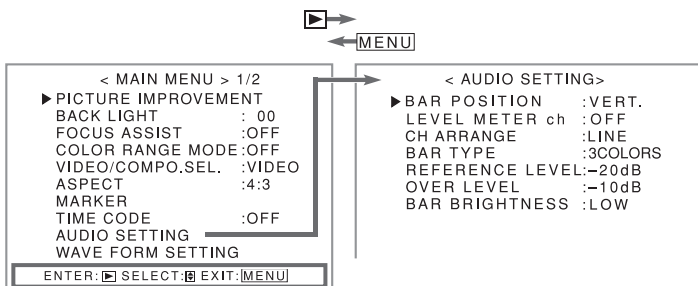

Operation guide
Shows the buttons for each operation.

- The menu automatically disappears in about 30 seconds after the previous operation.
- Some items may not appear on the menu depending on the input or the input signal.
- The items controlled by the MAKE system do not appear on the menu.

AUDIO SETTING

Settings for the level meter

Item	To do	Setting value
BAR POSITION	Select the type of the level meter display — vertically or horizontally.	VERT. (vertically), HORZ. (horizontally)
LEVEL METER ch	Select the number of the audio channels displayed on the level meter.	OFF, 12CH, 8CH
CH ARRANGE	Select the order of the audio channels displayed on the level meter.	LINE, DIVIDE (≡ “NOTE”)
BAR TYPE	Select the color of the level meter display.	3COLORS (3 colors to indicate variations in input levels), W.100 (white), W.50 (half tone)
REFERENCE LEVEL	Select the standard input level indicated on the level meter.	-20dB, -18dB
OVER LEVEL	Select the input level's lower limit indicated in red for the “3COLORS” display.	-10dB, -8dB, -6dB, -4dB, -2dB
BAR BRIGHTNESS	Select the brightness of the level meter.	LOW, HIGH

NOTE

Example of the level meter display—Level meter position and audio channels

Ex.: When “LEVEL METER ch” is set to “8CH” and “BAR TYPE” is set to “3COLORS.”

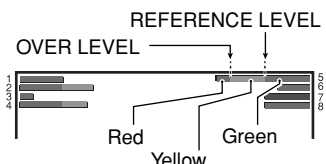

Ex.: BAR POSITION: HORZ.,
CH ARRANGE: LINE

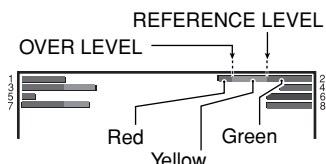

Ex.: BAR POSITION: HORZ.,
CH ARRANGE: DIVIDE

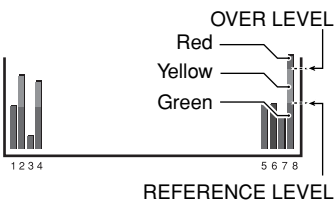

Ex.: BAR POSITION: VERT.,
CH ARRANGE: LINE

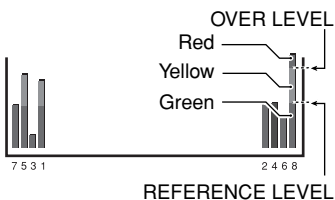

Ex.: BAR POSITION: VERT.,
CH ARRANGE: DIVIDE

- When “CH ARRANGE” is set to “DIVIDE,” odd channels are displayed on the left and even channels are displayed on the right.
- When “BAR TYPE” is set to “W.100” or “W.50,” the standard input level set in the “REFERENCE LEVEL” is displayed with the line indication. The input level set in “OVER LEVEL” is not displayed.
- The level meter with no signal input is displayed in white for “3COLORS,” and in gray for “W.100” or “W.50.”

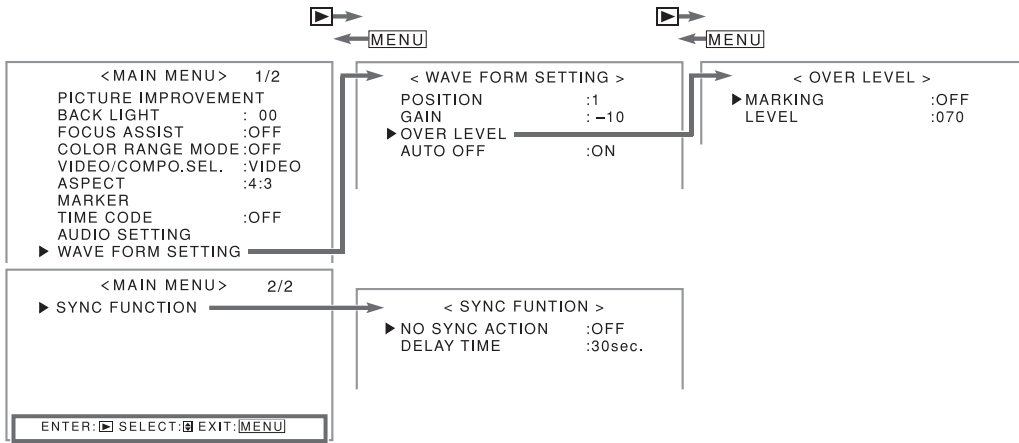

Operation guide

Shows the buttons for each operation.

- The menu automatically disappears in about 30 seconds after the previous operation.
- Some items may not appear on the menu depending on the input or the input signal.
- The items controlled by the MAKE system do not appear on the menu.

NOTE

Example of the wave form monitor

Ex.: When "MARKING" is set to "ON" and "LEVEL" is set to "080"

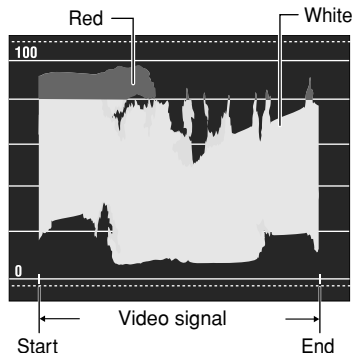

- The wave which goes over the value set on "LEVEL" is indicated in red.

WAVE FORM SETTING

Settings for the wave form monitor

Item	To do	Setting value
POSITION	Select the position of the wave form monitor.	1 (lower right), 2 (lower left), 3 (upper left), 4 (upper right)
GAIN	Adjust the gain level for the incoming wave form data.	-10 - +10
OVER LEVEL	Select the over level for the incoming luminance signals.	☞ "NOTE"
MARKING	Activates/deactivates the function to change the color of a wave form when the signal exceeds the limit specified on "LEVEL" (☞ below).	OFF, ON
LEVEL	Adjust the lower limit for the luminance signal	070 -109
AUTO OFF	Activates/deactivates the function to make the wave form monitor indication go off automatically 15 minutes after displaying it.	ON, OFF

SYNC FUNCTION

Settings for the synchronization with signals

Item	To do	Setting value
NO SYNC ACTION	Select the screen status when no signal is coming in.	OFF, P.SAVE (power save mode), GRAY B. (gray screen)
DELAY TIME	Select the period until the screen status changes as selected in "NO SYNC ACTION" after signals stop coming in.	30sec., 5min., 15min.

- When setting "NO SYNC ACTION" to "GRAY B.," the screen color changes to gray and the power consumption of the back light is saved by half.
Selecting "P.SAVE" (power save mode) saves more power consumption by turning off the back light.

For the operation procedure, see page 7.

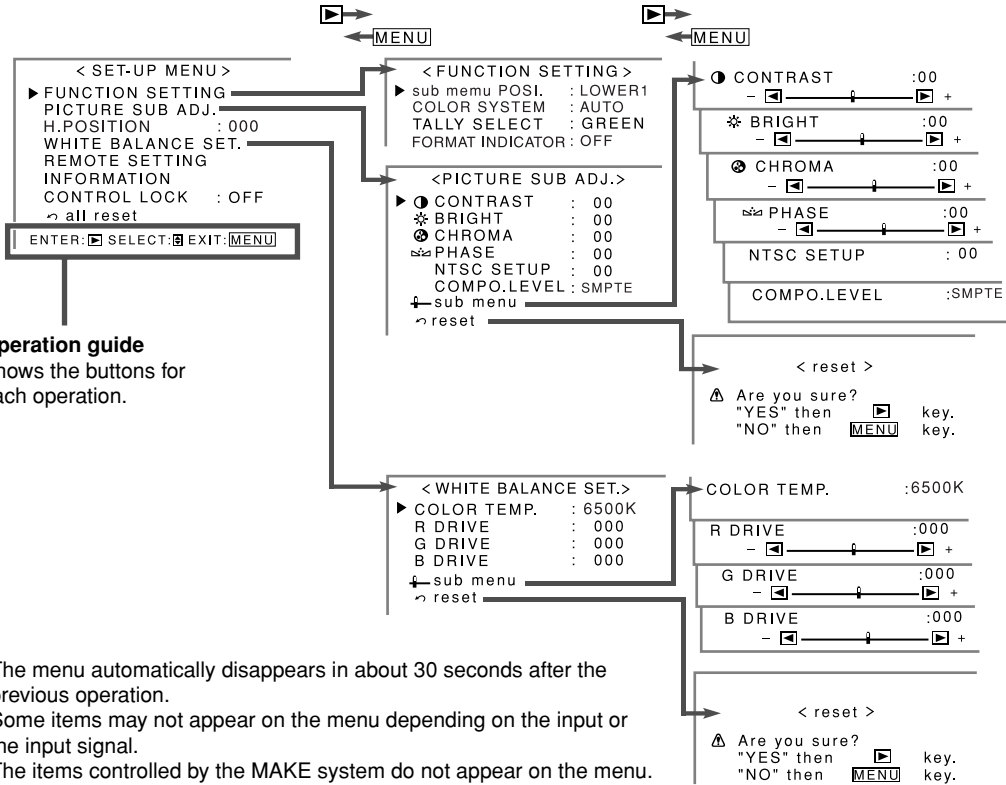

Operation guide
Shows the buttons for each operation.

- The menu automatically disappears in about 30 seconds after the previous operation.
- Some items may not appear on the menu depending on the input or the input signal.
- The items controlled by the MAKE system do not appear on the menu.

NOTE

Settings of “sub menu POSI.”

The setting values and features are as follows.

- LOWER1:** Displays the current setting and adjustment bar at the lower part of the screen.
- UPPER1:** Displays the current setting and adjustment bar at the upper part of the screen.
- LOWER2:** Displays the current setting at the lower part of the screen.
- UPPER2:** Displays the current setting at the upper part of the screen.

- The adjustment bar is not displayed for some items.

Color of the format indicator

When “FORMAT INDICATOR” is set to “ON,” the tally lamp lights as follows according to the incoming video signal.

Lights in green: 720/60p, 720/59.94p, 720/50p, 1080/60i, 1080/59.94i, 1080/50i, 1035/60i, 1035/59.94i, 1080/24psF, 1080/23.98psF, 1080/30psF, 1080/25psF, 1080/29.97psF

Lights in red: 480/60i, 480/59.94i, 576/50i, 480/60p, 480/59.94p, 576/50p

Lights in orange: composite signal

- The lamp goes off when the non-compliant video signals are coming in.

FUNCTION SETTING

Settings for the sub menu display, color system, color of the tally lamp, and the format indicator.

Item	To do	Setting value
sub menu POSI.	Select the contents and displaying position of “sub menu.”	☞ “NOTE”
COLOR SYSTEM	Select the color system. • If the picture is unstable with “AUTO,” select “NTSC” or “PAL.”	AUTO, NTSC, PAL
TALLY SELECT	Select the color of the tally lamp.	GREEN, RED
FORMAT INDICATOR	Select whether to use the tally lamp as the format indicator.	OFF, ON (☞ “NOTE”)

- When “FORMAT INDICATOR” is set to “ON,” the TALLY function of the MAKE/TRIGGER terminal is not available.

PICTURE SUB ADJ.

Adjusts the standard level for the picture adjustment and selects the set-up level for the input video signal.

Item	To do	Setting value
CONTRAST*†	Adjust the standard level for the contrast adjusted with CONTRAST knob on the front panel.	-20 – +20
BRIGHT*†	Adjust the standard level for the brightness adjusted with BRIGHT knob on the front panel.	-20 – +20
CHROMA*†	Adjust the standard level for the chroma adjusted with CHROMA knob on the front panel.	-20 – +20
PHASE*†	Adjust the standard level for the phase adjusted with PHASE knob on the front panel.	-20 – +20
NTSC SETUP	Select the set-up level of the input NTSC signal.	00 (compliant with 0% set-up signal), 7.5 (compliant with 7.5% set-up signal)
COMPO. LEVEL	Select the level of the analog component signal (480i and 576i only).	B75 (compliant with BetacamVTR 7.5% set-up signal), B00 (compliant with BetacamVTR 0% set-up signal), SMPTE (compliant with M2VTR signals)
sub menu	Display the sub menu which enables you to adjust the items in “PICTURE SUB ADJ.” while viewing the actual picture.	
reset	Restore the default settings for all the items in “PICTURE SUB ADJ.”	

- When the DYNAMIC lamp lights, “PICTURE SUB ADJ.” does not appear on the menu (☞ [8] on page 6).

H. POSITION*† Setting value: -003 – +003

Adjusts the horizontal picture position.

WHITE BALANCE SET.

Selects the color temperature and adjusts the drive level of each color (R/G/B).

Item	To do	Setting value
COLOR TEMP.	Select the color temperature.	9300K, 6500K, USER
R DRIVE, G DRIVE, B DRIVE*‡	Adjust the drive level of each color (red, green, and blue).	MIN – 000 – MAX (in 256 grades)
sub menu	Display the sub menu which enables you to adjust the items in “WHITE BALANCE SET.” while viewing the actual picture.	
reset	Restore the default settings for the drive levels of the selected color temperature.	

- When “COLOR RANGE MODE” is set to “ON,” “WHITE BALANCE SET.” does not appear on the menu (☞ page 10).

*† Memorized for each input — composite signal input (VIDEO), component signal input (COMPO.), SDI 1 and SDI 2.

*‡ Memorized for each color temperature.

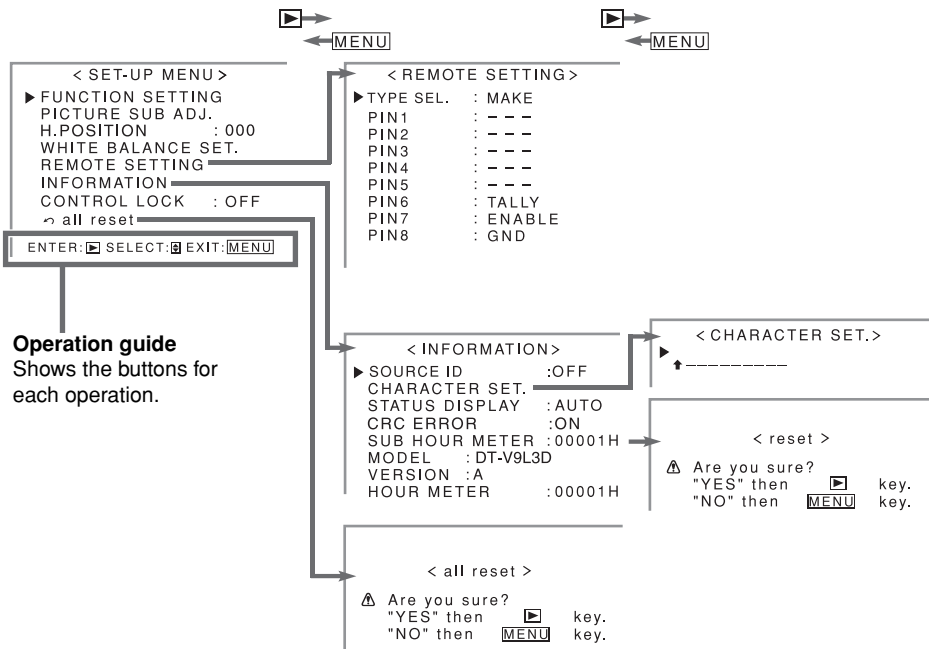

Operation guide
Shows the buttons for each operation.

- The menu automatically disappears in about 30 seconds after the previous operation.
- Some items may not appear on the menu depending on the input or the input signal.
- The items controlled by the MAKE system do not appear on the menu.

NOTE

Setting of "CHARACTER SET."

Assign a name for each video source.

- 1 Change the input to one that you want to assign a video source name for.
 - You cannot store different video source names for composite signal input (VIDEO) and component signal input (COMPO.).
- 2 Select "CHARACTER SET."
- 3 Press Δ ∇ buttons to select the first character.
 - Each time you press Δ button, the character changes as follows. Press ∇ button to reverse the order.

→ Space → 0 - 9 → A - Z → a - z → &()*+,-./:<>_
- 4 Press \triangleright button to move the arrow to the next space.
 - The characters entered before moving the arrow are memorized.
- 5 Repeat steps 3 and 4 (10 characters at maximum).
- 6 Press MENU button to store the name.



REMOTE SETTING (External Control on pages 16, 17)

Settings for the external control

Item	To do	Setting value
TYPE SEL.	Select the external control method for the MAKE/TRIGGER terminal.	MAKE, TRIGGER, SET
PIN1, PIN2, PIN3, PIN4, PIN5	Assign the control functions to the pins of the MAKE/TRIGGER terminal. <ul style="list-style-type: none"> • Assign a function to each pin terminal by selecting "SET" in "TYPE SEL." mentioned above. (The functions are assigned for "PIN6" – "PIN8" and you cannot change the assignment of these functions.) 	TALLY SEL, SDI 1, SDI 2, VIDEO/COMPO., MARKER, FRAME, C.MARKER, MARK.SEL, ASPECT, STATUS, L.METER, TIME CODE, SOURCE ID, WAVE FORM, COLOR OFF, SCR CHECK, DYNAMIC, FOCUS ASSIST, COLOR RANGE, MUTING, --- (no function)

INFORMATION

Settings for the information display of the monitor

Item	To do	Setting value
SOURCE ID	Select if the name assigned in "CHARACTER SET." is displayed on the screen (External Control on page 7).	OFF, ON
CHARACTER SET.	Assign a name to each video source as you like (10 characters at maximum). You can also enter a name using the RS-232C system.	External Control
STATUS DISPLAY	Select if the status of the current input and the setting of muting are displayed on the screen (External Control on page 7).	AUTO, OFF, ON
CRC ERROR	Select if the CRC error indication for the input HD SDI signal is displayed on the screen (External Control on page 7).	ON, OFF
SUB HOUR METER	Display the hours of use (unit: hour). You can reset this item.	
MODEL	Display the model name of the monitor.	
VERSION	Display the version of the monitor.	
HOURLY METER	Display the total hours of use (unit: hour). This item is used for maintenance of the monitor. You cannot reset this item.	

CONTROL LOCK Setting value: OFF, ON

Turns on (or off) the control lock function to disable the buttons on the front panel.

- The following operations are available even when this function is activated.
 - Turning on/off (on standby) the monitor
 - Displaying the SET-UP MENU (by pressing \triangleleft button while holding ∇ button) and turning "CONTROL LOCK" to "OFF"
 - Operating the monitor by an external control
- If you try other operations, "Control lock on!" appears on the screen.

all reset

Restores all the settings and adjustments of the monitor to the default.

- "HOURLY METER" and the settings done by using the adjustment knobs on the front panel will not be reset.
- When you operate the monitor with the AC power supply, the monitor is turned off (on standby) then turned on automatically. When you operate the monitor with the DC 12 V power supply, the monitor is turned off (on standby).

About the external control

This monitor has two external control terminals.

- **MAKE/TRIGGER terminal (RJ-45):** The following external control systems are available.
 - (1) **MAKE (make contact) system:** Controls the monitor by short-circuiting the corresponding pin terminal to the GND pin terminal, or disconnecting (opening) it (see below).
 - (2) **TRIGGER (trigger) system:** Controls the monitor by sending the pulse signal instantaneously to the corresponding pin terminal (see below).
- **RS-232C terminal (D-sub 9-pin):** Controls the monitor with the RS-232C system. (see page 17)
- Control priority is as follows.
 - MAKE > TRIGGER, RS-232C, buttons and menu on the monitor**
- You can use the external control even when "CONTROL LOCK" is set to "ON" (see page 15).
- When the monitor is off (on standby), external control is not available.

Using the MAKE/TRIGGER system

You can control the monitor by a personal computer or dedicated controller*1.

*1 The controller is not commercially available. Consult your dealer if you need it.

The MAKE/TRIGGER terminal is configured as follows. You can assign a function to each pin terminal in "REMOTE SETTING" (see "PIN1, PIN2, PIN3, PIN4, PIN5" on page 15).

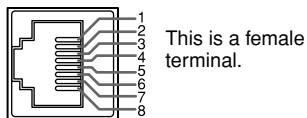

This is a female terminal.

Pin No.	Pin name	Pin No.	Pin name
1	PIN1	5	PIN5
2	PIN2	6	PIN6 (TALLY)*2
3	PIN3	7	PIN7 (ENABLE)*3
4	PIN4	8	PIN8 (GND)

*2 The 6th pin terminal controls turning on or off the tally lamp (available to control even when the 7th pin terminal is invalid.)

*3 The 7th pin terminal makes the external control valid/invalid. Make sure to control the terminal by the MAKE system.

- You cannot change the functions assigned to the pin terminals from 6th to 8th.
- When "FORMAT INDICATOR" in "FUNCTION SETTING" is set to "ON," the TALLY lamp cannot be controlled by the external control (see page 14)
- You cannot assign the same function to different pin terminals.
- The TRIGGER system switches each function by short-circuiting the pin terminal for about 1 second and opening it.

To assign the functions to the pin terminals

For the operation procedure, see page 7.

- 1 Select "REMOTE SETTING" on the SET-UP MENU.
- 2 Set "TYPE SEL." to "SET."
- 3 Select a pin name ("PIN1" – "PIN5") for which you want to assign a function, then select the function you want to assign.
 - For selectable functions, see the table on the right.

Functions controlled by the MAKE/TRIGGER system

Display	Functions to be controlled	Opening	Short-circuiting
TALLY SEL	Selects the color of the tally lamp.	Green	Red
SDI 1	Changes the input to "SDI 1."	Invalid	Valid
SDI 2	Changes the input to "SDI 2."	Invalid	Valid
VIDEO/COMPO.	Changes the input to "VIDEO/COMPO."	Invalid	Valid
MARKER	The area marker and the safety marker indication	Off	On
FRAME	Indication of the area of the specified aspect ratio	Off	On
C.MARKER	The center marker indication	Off	On
MARK.SEL	Selects the items of "MARKER"*4	Non-"R-" items	"R-" items
ASPECT	Changes the aspect ratio.	4:3	16:9
STATUS	Status display*5	see "On the Status Display" on page 7	
L.METER	Audio level meter display	*6	
TIME CODE	Time code display	Off	On
SOURCE ID	see "SOURCE ID" on page 15	Off	On
WAVE FORM	Wave form monitor display*7	Off	On
COLOR OFF	Color off	Color	Monochrome
SCR CHECK	Screens check	*8	
DYNAMIC	Adjusts the picture to be suitable for a bright place.	Off	On
FOCUS ASSIST	Helps to focus the picture.	Off	On
COLOR RANGE	Reduces the difference of the luminance level specific to the LCD panel.	Off	On
MUTING	Muting on/off	Off	On
— — —	No function	—	—

*4 Selects which functions in "MARKER" are activated, non-"R-" items or "R-" items (see page 11).

*5 Displays the information shown when the button of the current input is pressed (see "On the Status Display" on page 7). While controlling with the MAKE system, the information is displayed only at the moment of short-circuiting.

*6 While controlling with the MAKE system, the level meter is switched between displayed (short-circuiting) and hidden (opening). When "LEVEL METER ch" is set to "OFF," the level meter is not displayed ("NO EFFECT" appears). While controlling with the TRIGGER system, the number of the audio channels displayed is changed (between OFF, 12CH and 8CH).

*7 While controlling with the MAKE system, the wave form monitor will not disappear until opening the terminal even when "AUTO OFF" is set to "ON."

*8 While controlling with the MAKE system, the screen is switched between normal screen (opening) and blue screen (short-circuiting). While controlling with the TRIGGER system, the screen changes as follows:

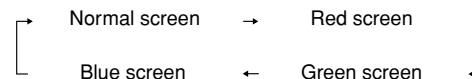

Operation of the external control

- 1 Set "TYPE SEL." of "REMOTE SETTING" to "MAKE" or "TRIGGER" in the SET-UP MENU.
- 2 Short-circuit the 7th pin terminal (ENABLE) to the 8th pin terminal (GND) so that the monitor can be controlled by the external control.
- 3 When the "MAKE" system is selected: Operate each function by short-circuiting the corresponding pin terminal to the 8th pin terminal (GND) or opening it.
 - When the "TRIGGER" system is selected: Operate each function by pulse control, that is short-circuiting the corresponding pin terminal to the 8th pin terminal (GND) for about 1 second and opening it.
- When changing the input with MAKE system, only one pin terminal must be short-circuited. (Other pin terminals must be opened.)
- When selecting the TRIGGER system, you can operate only one function at a time. Operate the functions one by one.

■ Using the RS-232C system

You can control the monitor from a personal computer etc. via the RS-232C terminal.

- Consult your dealer for the details of the external control specification.

<Communication specifications>

Baud Rate: 4800 bps

Data Bits: 8 bits

Parity: No parity

Stop Bits: 1 bit

Flow Control: No control

Communication Code: ASCII Code

- Use a straight cable with a D-sub 9-pin connector (male for the monitor, female for the personal computer).

<Command outline>

All commands consist of the following segments.

Header	Monitor ID (00)	Command ID	Function	Data	Cr (0Dh)
--------	-----------------	------------	----------	------	----------

Header

"!": Operation commands from the personal computer, etc. For details, see <Basic command list> on the right.

"?": Reference commands from the personal computer, etc.

"@": Status returns from the monitor

- To start communication, send the connection command from the personal computer etc.
- To terminate the communication, send the termination command from the personal computer etc.

Example of communication procedures

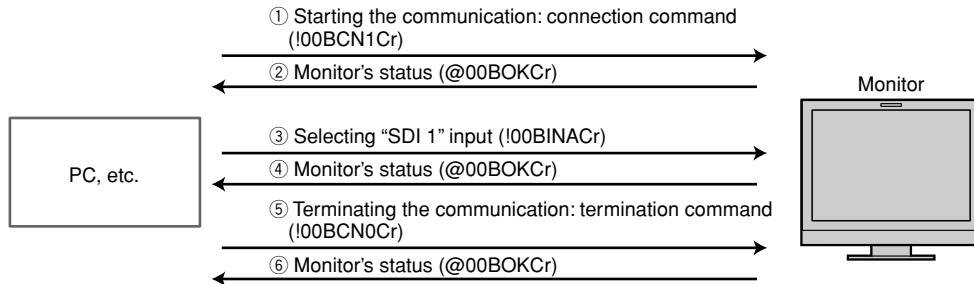

<Basic command list>

No.	Commands	Functions	Data
1	! 0 0 B C N 1 Cr	Starts communication (connection)	No data
2	! 0 0 B C N 0 Cr	Terminates communication (termination)	No data
3	! 0 0 B M E N U Cr	Displays the MAIN MENU/Quits the menu operation	No data
4	! 0 0 B U P Cr	Moves the cursor upward (△)	No data
5	! 0 0 B D O W N Cr	Moves the cursor downward (▽)	No data
6	! 0 0 B A D J R Cr	Makes setting/adjustment (▷)	No data
7	! 0 0 B A D J L Cr	Makes setting/adjustment (◁)	No data
8	! 0 0 B S E T U P Cr	Displays the SET-UP MENU	No data
9	! 0 0 B P W 1 Cr	Turns on the monitor	No data
10	! 0 0 B P W 0 Cr	Turns off the monitor (standby)	No data
11	! 0 0 B I N A Cr	Selects "SDI 1" input	No data
12	! 0 0 B I N B Cr	Selects "SDI 2" input	No data
13	! 0 0 B I N C Cr	Selects "VIDEO/COMPO." input	No data
14	! 0 0 B D I S P Cr	Displays the status*2	No data
15	! 0 0 B V P L S Cr	Increases the volume level	No data
16	! 0 0 B V M N S Cr	Decrease the volume level	No data
17	! 0 0 B V O L x x*1 Cr	Adjusts the volume level	00 - 30
18	! 0 0 B A M U T E x x*1 Cr	Turns muting on/off	00: Off, 01: On
19	! 0 0 B A S P x x*1 Cr	Changes the aspect ratio	00: 4:3, 01: 16:9

- "Cr" is 0Dh.

- The commands for starting communication (connection) (No. 1), terminating communication (termination) (No. 2), and turning on the monitor (No. 9) can be used while the monitor is off (on standby).

*1 Enter the appropriate data to "xx".

*2 Displays the information shown when the button of the current input is pressed (☞ "On the Status Display" on page 7).

<Specifications of the RS-232C terminal>

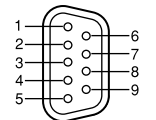

Pin No.	Signal
1	NC
2	RXD
3	TXD
4	NC
5	GND
6	NC
7	RTS
8	CTS
9	NC

- The 7th terminal and the 8th terminal are connected.

Solutions to common problems related to the monitor are described here. If none of the solutions presented here solve the problem, unplug the monitor and consult an authorized dealer or service center.

Symptom	Probable cause and corrective action	Page
No power supply	• Press the  button.	6
	• Turn on the POWER switch or DC switch on the rear panel.	8
	• Firmly insert the AC power plug or DC 12 V power plug.	8
	• When using a DC 12 V power supply, charge the battery or replace it with a charged one.	8
No picture with the power on	• Select the correct input.	6
	• Connect the signal cable firmly.	8
	• Turn on the power of the connected component and set the output correctly.	—
	• Check whether the input signal format is acceptable on the monitor.	9
No sound	• Adjust the volume level.	6
	• Deactivate the muting function.	6
	• Connect the signal cable firmly.	8
	• Turn on the power of the connected component and set the output correctly.	—
“OTHERS” or “Out of range” appears.	• Check whether the input signal format is acceptable on the monitor.	7, 9
“NO SYNC” appears.	• Select the correct input.	6
	• Connect the signal cable firmly.	8
	• Turn on the power of the connected component and output video signals. Or, check whether the video output of the component (video output setting of the VCR) is set correctly.	—
Wrong color, no color	• Adjust each picture adjustment knob on the front panel or adjust the items of “PICTURE SUB ADJ.” in the SET-UP MENU. Or, perform “reset” in “PICTURE SUB ADJ.”	6, 14
	• Check if the screen mode is other than normal screen, by using SCR. CHK. button.	6
	• Select the proper color system (“COLOR SYSTEM”) in “FUNCTION SETTING” of the SET-UP MENU.	14
	• Adjust the items of “WHITE BALANCE SET.” in the SET-UP MENU. Or, perform “reset” in “WHITE BALANCE SET.”	14

Symptom	Probable cause and corrective action	Page
The picture becomes blurred.	• Adjust the picture contrast or brightness by using the adjustment knobs on the front panel. Or, adjust “CONTRAST” or “BRIGHT” of “PICTURE SUB ADJ.” in the SET-UP MENU.	6, 14
Wrong picture position, wrong picture size.	• Check whether the input signal format is acceptable on the monitor.	7, 9
	• Check the setting of “ASPECT” in the MAIN MENU.	10
Some items do not appear on the menu.	• Adjust the horizontal picture position in “H. POSITION” of the SET-UP MENU.	14
	• For some signals, the picture cannot be displayed fully in the effective screen area. There is no sure method to solve this problem.	—
Buttons on the monitor do not work.	• The items which are not available for the current input or the current input signal are not displayed on the menu. Change the input or the input signal.	—
	• The items controlled by the MAKE system do not appear on the menu.	16
Buttons on the monitor do not work.	• Set “CONTROL LOCK” in the SET-UP MENU to “OFF.”	15
	• You cannot use the buttons for the items controlled by the MAKE system. Disable the external control.	16

The following are not malfunctions.

- When a still image is displayed for a long time, it may remain indistinctly on the screen after the picture has changed. Though the remaining picture will disappear after a while, there may be a case that it remains for a long period depending on the length of time the still image was displayed for. This is due to the characteristics of the LCD display and is not a malfunction.
- Red spots, blue spots and green spots on the panel surface are a normal characteristic of LCD displays, and not a problem. The LCD display is built with very high precision technology; however, be aware that a few pixels may be missing or constantly lit.
- The following symptoms are problems only when pictures or sounds are not played back normally.
 - A slight electric shock occurs when you touch the monitor.
 - The top and/or rear panel of the monitor becomes hot.
 - The monitor emits a cracking noise.
 - The monitor emits a mechanical noise.

■ Self-check program

This monitor has a self-check function, which allows it to detect malfunctions and alert you. This makes troubleshooting easier. Whenever a problem occurs, one or some of the self-check lamps will flash. If this happens, follow the steps below and contact your dealer to resolve the problem.

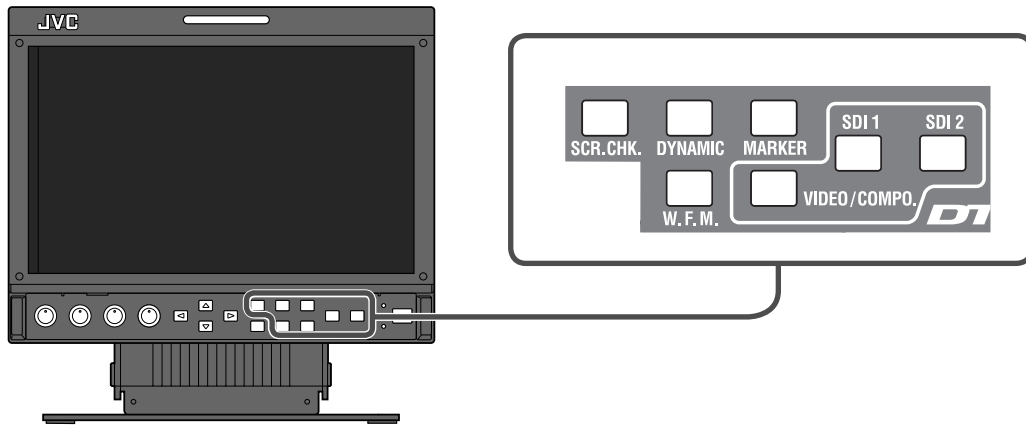

When the screen goes blank and one or some of the self-check lamps on the front control panel start flashing...

- 1 Check which lamps are flashing.**
- 2 Press \odot /I button to turn off (on standby) the monitor.**
- 3 Turn off the POWER switch and DC switch on the rear panel.**
- 4 When the AC power supply is used: Disconnect the AC power cord from the AC outlet.**
When a DC 12 V power supply is used: Detach the battery or disconnect the plug from the DC IN terminal.
- 5 Contact your dealer with the information about which lamps were flashing.**

- If you turn on the monitor soon after turning it off (or after a short-term power failure), the self-check lamps may flash and no image may be displayed. When this happens, turn off power and wait at least 10 seconds before turning on the monitor again. If the self-check lamps do not flash, you can use the monitor as normal.

Unplug this product from the wall outlet before cleaning.

Screen

To avoid irreparable change in appearance of the screen such as uneven color, discoloration, scratches, be careful about the following:

- Do not paste or stick anything using any glues or adhesive tapes.
- Do not write anything on the screen.
- Do not strike the screen with a hard object.
- Avoid condensation on the screen.
- Do not wipe the screen with solvent such as alcohol, thinner, or benzine.
- Do not wipe the screen forcefully.

Wipe stains off the screen with a soft cloth. If the screen gets heavily stained, wipe it with a soft cloth soaked in water-diluted neutral detergent and wrung well, then wipe with a soft dry cloth.

Cabinet

To avoid the deterioration or damages of the cabinet such as its paint's peeling away, be careful about the following:

- Do not wipe the cabinet using solvent such as alcohol, thinner, or benzine.
- Do not expose the cabinet to any volatile substance such as insecticides.
- Do not allow any rubber or plastic in contact for a long time.
- Do not wipe the cabinet forcefully.

Wipe stains off the cabinet with a soft cloth. If the cabinet gets heavily stained, wipe it with a soft cloth soaked in water-diluted neutral detergent and wrung well, then wipe with a soft dry cloth.

Ventilation openings

Use a vacuum cleaner to get rid of the dust around the intakes (all the openings). If a vacuum cleaner is not available, use a cloth and wipe it off. Leaving the dust around the intakes may prevent proper temperature control and cause damage to the product.

Specifications

■ General

Model name	DT-V9L3D
Type	Multi format LCD monitor
Screen size	Type 9 wide format
Aspect ratio	15:9
LCD panel	9" wide, IPS-Pro
Effective screen size	Width: 195 mm Height: 117 mm
Number of pixels displayed	800 x 480
Number of colors displayed	16.77 million
Viewing angle (TYP.)	170° (Horizontally), 170° (Vertically)
Brightness	350 cd/m ²
Contrast ratio (TYP.)	400:1
Compliant video signal format	☞ "Available signals" on page 9
Format	HD SDI: BTA S-004B, SMPTE292M SD SDI: ITU-R BT.656: 525/625 SMPTE259M: 525 EMBEDDED AUDIO: SMPTE299M, SMPTE272M
Audio output	Internal speaker: 1.0 W
Operating conditions	Operating temperature: 0°C – 40°C Operating humidity: 20 % – 80 % (non-condensing) * Slightly variable depending on ambient conditions for installation.
Power requirements	AC 220 – 240 V, 50 Hz/60 Hz DC 12 – 17 V
Rated current	0.25 A (AC 220 – 240 V) 1.7 A (DC 12 – 17 V)
External dimensions (excluding protruding parts)	Width: 222.4 mm Height: 218 mm (at the higher position), 181 mm (at the lower position), 176 mm (without stand) Depth: 185 mm (at the higher position), 202 mm (at the lower position), 116 mm (without stand)
Weight	3.6 kg (with the stand) 2.7 kg (without the stand)
Accessories	AC power cord x 2, Power cord holder x 1, Screw x 2 (for power cord holder), Protective filter x 1, Screw (for protective filter) x 4

Use the Anton Bauer Dionic 90 (mount: QR DXC-M3A) external battery.

CAUTION

Danger of explosion if battery is incorrectly replaced. Replace only with the same or equivalent type.

Notice on transportation

This monitor is precision equipment and needs dedicated packing material for transportation.
Never use any packing material supplied from sources other than JVC or JVC-authorized dealers.

■ Input/output terminals

Video	VIDEO/COMPONENT (IN/OUT)	VBS/Y Composite signal/analog component (Y) signal input/output: 1 line, BNC connector x 2 1 V(p-p), 75 Ω * The input (IN) and output (OUT) terminals are bridge-connected (auto termination) P _B , P _R Analog component (P _B , P _R) signal input: 1 line, BNC connector x 2 0.7 V(p-p), 75 Ω
	E. AUDIO HD/SD SDI (IN 1)	Digital signal input (compatible with EMBEDDED AUDIO signals): auto detection, 1 line, BNC connector x 1
	E. AUDIO HD/SD SDI (IN 2)	
Audio	E. AUDIO HD/SD SDI (SWITCHED OUT)	Digital signal output (compatible with EMBEDDED AUDIO signals): 1 line switched out, BNC connector x 1
	AUDIO (IN)	Analog audio signal input: 1 line, RCA connector x 1, 500 mV (rms), high impedance
	AUDIO (MONITOR OUT)	Analog audio signal output: 1 line, RCA connector x 2, 500 mV (rms)
External control	EARPHONE	Monaural mini jack (3.5 mm in diameter) x 1
	REMOTE (MAKE/TRIGGER)	☞ "Using the MAKE/TRIGGER system" on page 16
	REMOTE (RS-232C)	☞ "Using the RS-232C system" on page 17

- For easy understanding, pictures and illustrations are shown by being emphasized, omitted or composed, and may be slightly different from actual products.
- Design and specifications are subject to change without notice.
- All company names and product names mentioned herein are used for identification purposes only, and may be the trademarks or registered trademarks of their respective companies.

■ Dimensions Unit: mm

<Front view>

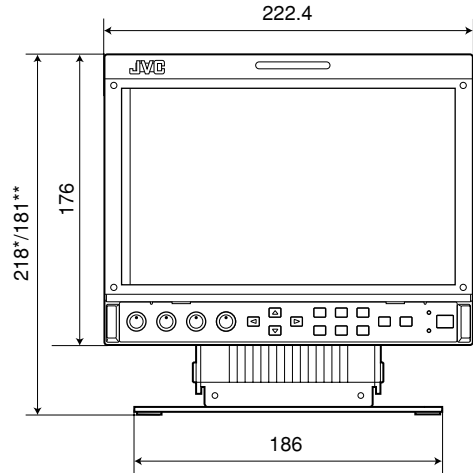

* at the higher position
** at the lower position

<Side view>

- When the stand is attached to the higher position.

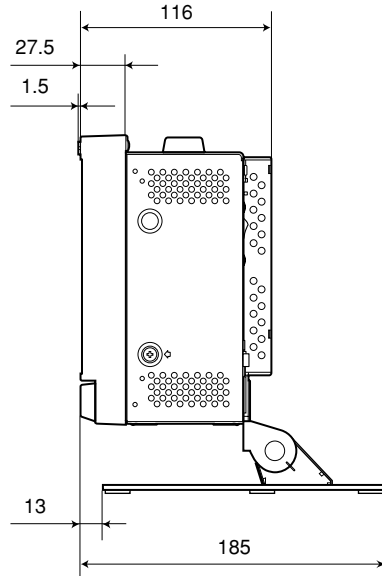

- When the stand is attached to the lower position.

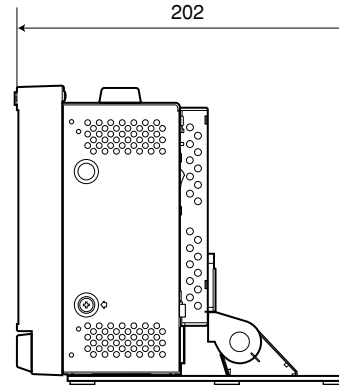

<Rear view>

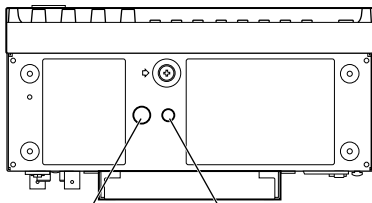
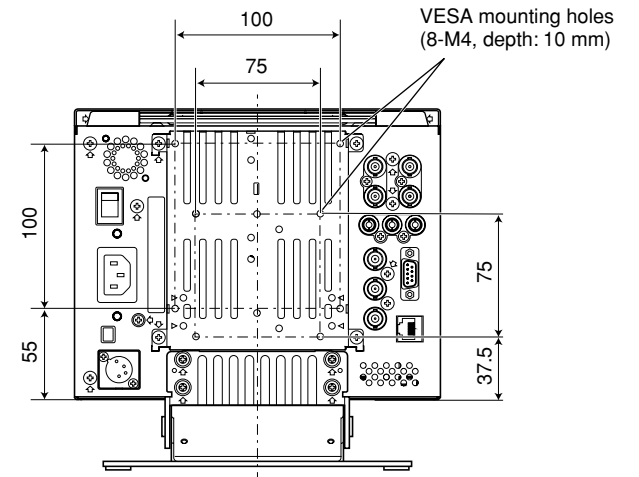





tapped hole (3/8") tapped hole (1/4")

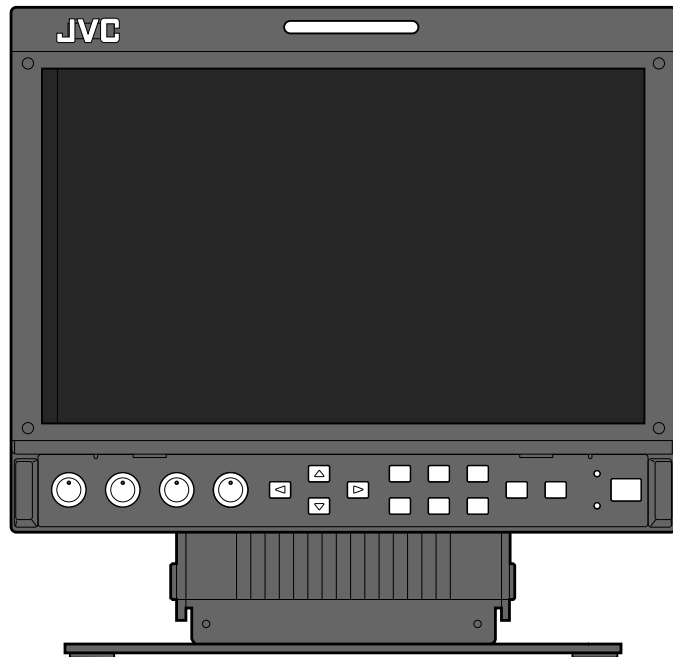

DT-V9L3DY

MULTI FORMAT LCD MONITOR



	CAUTION RISK OF ELECTRICAL SHOCK DO NOT OPEN	
<p>CAUTION: To reduce the risk of electric shock. Do not remove cover (or back). No user serviceable parts inside. Refer servicing to qualified service personnel.</p>		
	<p>The lightning flash with arrowhead symbol, within an equilateral triangle is intended to alert the user to the presence of uninsulated "dangerous voltage" within the product's enclosure that may be of sufficient magnitude to constitute a risk of electric shock to persons.</p>	
	<p>The exclamation point within an equilateral triangle is intended to alert the user to the presence of important operating and maintenance (servicing) instructions in the literature accompanying the appliance.</p>	

INSTRUCTIONS

Table of Contents	
Safety Precautions	2
IMPORTANT SAFEGUARDS	2
Installation	4
To adjust the stand height	4
Daily Operations / Connections	6
Front panel	6
Rear panel.....	8
Available signals	9
Menu Configuration—MAIN MENU	10
Menu Configuration—SET-UP MENU	14
External Control	16
About the external control	16
Using the MAKE/TRIGGER system	16
Using the RS-232C system	17
Troubleshooting	18
Self-check program	19
Maintenance	20
Specifications	21
General.....	21
Input/output terminals.....	21
Dimensions.....	22

Safety Precautions

WARNING: TO REDUCE RISK OF FIRE OR ELECTRIC SHOCK, DO NOT EXPOSE THIS APPARATUS TO RAIN OR MOISTURE. NO OBJECTS FILLED WITH LIQUIDS, SUCH AS VASES, SHALL BE PLACED ON THE APPARATUS.

IMPORTANT SAFEGUARDS

Electrical energy can perform many useful functions. This unit has been engineered and manufactured to assure your personal safety. But **IMPROPER USE CAN RESULT IN POTENTIAL ELECTRIC SHOCK OR FIRE.** In order not to defeat the safeguards incorporated into this product, observe the following basic rules for its installation, use, and service. Please read these "IMPORTANT SAFEGUARDS" carefully before use.

- All the safety and operating instructions should be read before the product is operated.
- The safety and operating instructions should be retained for future reference.
- All warnings on the product and in the operating instructions should be adhered to.
- All operating instructions should be followed.

POWER CONNECTION

The power supply voltage rating of this product is AC 120 V.

The power cord attached conforms to the following power supply voltage and countries. Use only the power cord designated to ensure safety and EMC regulations of each country.

For U.S.A. and Canada:
AC 120 V



This plug will fit only into a grounded power outlet. If you are unable to insert the plug into the outlet, contact your electrician to install the proper outlet. Do not defeat the safety purpose of the grounded plug.

- This product should be operated only with the type of power source indicated on the label. If you are not sure of the type of power supply of your home, consult your product dealer or local electric power company.

Warning: This is a class A product. In a domestic environment this product may cause radio interference in which case the user may be required to take adequate measures.

- Before connecting other products such as VCR's and personal computers, you should turn off the power of this product for protection against electric shock.
- Do not use attachments not recommended by the manufacturer as they may be hazardous.
- **When replacement parts are required**, be sure the service technician has used replacement parts specified by the manufacturer or equivalents. Unauthorized substitutions may result in fire, electric shock, or other hazards.
- **Upon completion of any service or repairs to this product**, ask the service technician to perform safety checks to determine that the product is in proper operating condition.

The rating label is on the bottom of the monitor.

Under the following conditions,

1. **Turn off the power.**
2. **Unplug this product from the wall outlet.**
3. **Refer service to qualified service personnel.**
 - a) When the product emits smoke or unusual smell.
 - b) When the product exhibits a distinct change in performance—for example, no picture or no sound.
 - c) If liquid has been spilled, or objects have fallen on the product.
 - d) If the product has been exposed to rain or water.
 - e) If the product has been dropped or damaged in any way.
 - f) When the power supply cord or plug is damaged.

- Do not install this product in the following places:
 - in a damp or dusty room
 - where the product is exposed to soot or steam, such as near the cooking counter or a humidifier
 - near heat sources
 - where condensation easily occurs, such as near the window
- Do not place this product on an unstable cart, stand, or table. The product may fall, causing serious injury to a child or adult, and serious damage to the product.

The product should be mounted according to the manufacturer's instructions, and should use a mount recommended by the manufacturer.

- Do not use this product near water.
- Be sure to install the product in the place where proper temperature and humidity are kept (☞ "Operating conditions" on page 21). This product becomes hot during its use. Take enough care when handling the product.

Do not attempt to service this product yourself, as opening or removing covers may expose you to dangerous voltages and other hazards. Refer all service to qualified service personnel.

Do not use the product for a long time if the sound is distorted.

- Use only the power source specified on the unit.
- AC power: 120 V, 50 Hz/60 Hz
 - DC power: 12 – 17 V

- The AC power supply is controlled by turning on/off the POWER switch on the rear panel. If the product is installed in a place where you cannot easily turn on/off the POWER switch, control the AC power supply by plugging/unplugging the power cord into/from the AC outlet. In this case, install the product as close to the AC outlet as possible, and leave enough space for plugging/unplugging the power cord. If the product is installed in a place where you cannot easily plug/unplug the power cord, equip an easily accessible device to the wiring of the building for turning on/off the power.
- When the product is left unattended and unused for a long period of time, unplug it from the wall outlet and disconnect the cable system.
- Do not overload wall outlets, extension cords, or convenience receptacles on other equipment as this can result in a risk of fire or electric shock.
- Use only the accessory cord designed for this product to prevent shock.

- Slots and openings in the cabinet are provided for ventilation. These ensure reliable operation of the product and protect it from overheating. These openings must not be blocked or covered.
- Never push objects of any kind into this product through openings as they may touch dangerous voltage points or short-circuit the parts, which could result in a fire or electric shock.
- Never spill liquid of any kind on the product.
- Never place anything on the product. (Placing liquids, naked flames, cloths, paper, etc. on the product may cause a fire.)
- Do not apply any strong shock to the LCD panel. (Do not hit any object against it or push it with a sharp-pointed tool.)
- Do not put heavy objects on the product.
- Do not step on or hang on the product.

Caution for use of the product in the high temperature

Do not use the product in places of high temperature; otherwise, parts of this product or the LCD panel may be damaged. This product is equipped with a temperature sensor to give warning if the temperature becomes too high. If the temperature exceeds the range of normal use, "TEMP. OVER" is displayed, and the power is turned off automatically if the temperature becomes any higher. In this case, move the product to a place of low temperature to let it cool down.

WARNING: TO PREVENT FIRE OR SHOCK HAZARDS, DO NOT EXPOSE THIS APPARATUS TO RAIN OR MOISTURE.

WARNING: THIS APPARATUS MUST BE CONNECTED TO A MAINS SOCKET OUTLET WITH A PROTECTIVE EARTHING CONNECTION.

CAUTION: DANGER OF EXPLOSION IF BATTERY IS INCORRECTLY REPLACED. REPLACE ONLY WITH THE SAME OR EQUIVALENT TYPE.

FCC NOTICE

CAUTION: Changes or modifications not approved by JVC could void the user's authority to operate the equipment.

NOTE: This equipment has been tested and found to comply with the limits for a Class A digital device, pursuant to Part 15 of the FCC Rules. These limits are designed to provide reasonable protection against harmful interference when the equipment is operated in a commercial environment. This equipment generates, uses, and can radiate radio frequency energy and, if not installed and used in accordance with the instruction manual, may cause harmful interference to radio communications. Operation of this equipment in a residential area is likely to cause harmful interference in which case the user will be required to correct the interference at his own expense.

IMPORTANT RECYCLING INFORMATION

This product has a fluorescent lamp that contains mercury. Disposal of these materials may be regulated in your community due to environmental considerations. For disposal or recycling information, please contact your local authorities or for USA, the Electronic Industries Alliance: <http://www.eiae.org>

IMPORTANT SAFETY INSTRUCTIONS

- 1) Read these instructions.
- 2) Keep these instructions.
- 3) Heed all warnings.
- 4) Follow all instructions.
- 5) Do not use this apparatus near water.
- 6) Clean only with dry cloth.
- 7) Do not block any ventilation openings. Install in accordance with the manufacturer's instructions.
- 8) Do not install near any heat sources such as radiators, heat registers, stoves, or other apparatus (including amplifiers) that produce heat.
- 9) Do not defeat the safety purpose of the polarized or grounding-type plug. A polarized plug has two blades with one wider than the other. A grounding type plug has two blades and a third grounding prong. The wide blade or the third prong are provided for your safety. If the provided plug does not fit into your outlet, consult an electrician for replacement of the obsolete outlet.
- 10) Protect the power cord from being walked on or pinched particularly at plugs, convenience receptacles, and the point where they exit from the apparatus.
- 11) Only use attachments/accessories specified by the manufacturer.
- 12) Use only with the cart, stand, tripod, bracket, or table specified by the manufacturer, or sold with the apparatus. When a cart is used, use caution when moving the cart/apparatus combination to avoid injury from tip-over.
- 13) Unplug this apparatus during lightning storms or when unused for long periods of time.
- 14) Refer all servicing to qualified service personnel. Servicing is required when the apparatus has been damaged in any way, such as power-supply cord or plug is damaged, liquid has been spilled or objects have fallen into the apparatus, the apparatus has been exposed to rain or moisture, does not operate normally, or has been dropped.
- 15) Apparatus shall not be exposed to dripping or splashing and no objects filled with liquids, such as vases, shall be placed on the apparatus.
- 16) Batteries shall not be exposed to excessive heat such as sunshine, fire or the like.
- 17) When discarding batteries, environmental problems must be considered and the local rules or laws governing the disposal of these batteries must be followed strictly.



Installation

CAUTION

- Do not rest your arm on the monitor or lean against the monitor.
- Do not touch the LCD panel when installing the monitor.
- Be sure to install the monitor securely to prevent the monitor from falling over, which may cause damage to the monitor or injury.

When shipped from factory, the stand is attached to the monitor.

You can tilt the monitor from about 20° upward to about 10° downward.

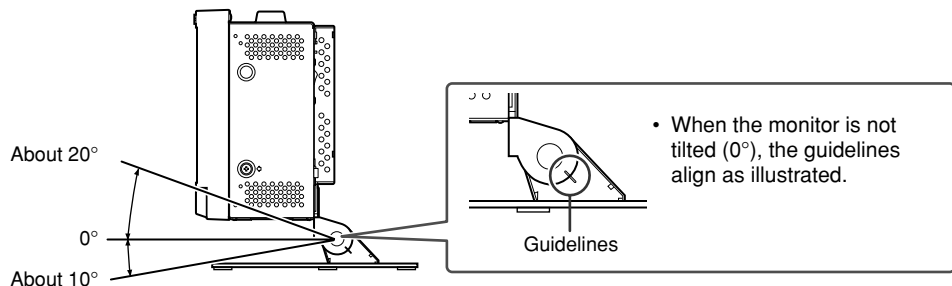

CAUTION

- Be careful not to pinch your fingers in the gap between the monitor and the stand.
- When the stand is attached to the lower position (see page 5), you cannot tilt the monitor downward.

■ To adjust the stand height

You can select the stand height according to your preference—higher position or lower position.

To change the stand height, change the position of the screw hole used for attaching the stand.

- When shipped from factory, the stand is attached to the higher position.
- Before adjusting the stand height, set the monitor angle to 0°.

CAUTION

- Lay the monitor on a cloth with the LCD panel facing down to prevent the LCD panel from being damaged.
- Depending on the type of external batteries, the stand cannot be attached or detached when the external battery is attached on the monitor.
- When the stand is attached on the lower position, some types of external batteries cannot be attached to the monitor.

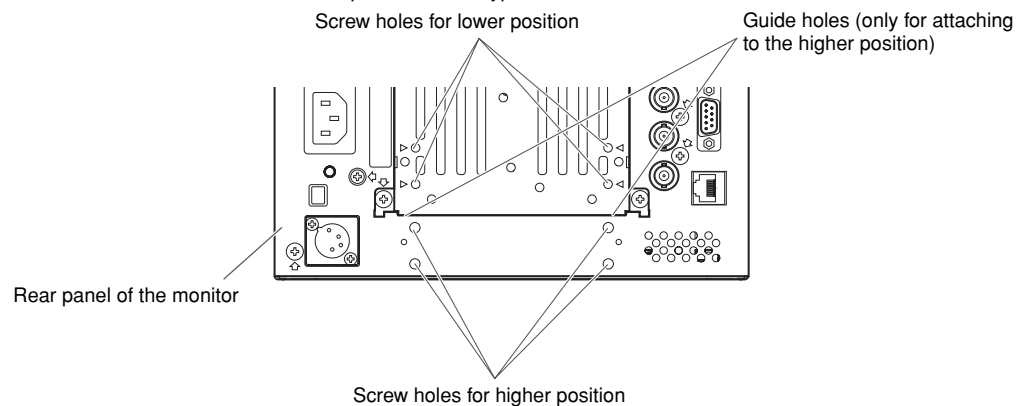

Higher position

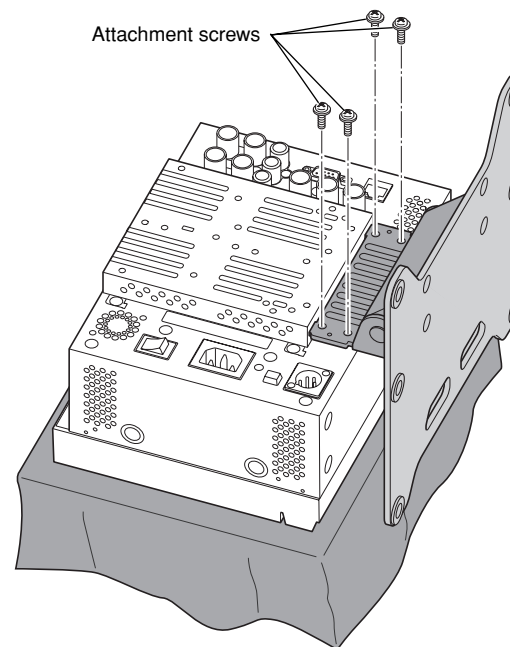
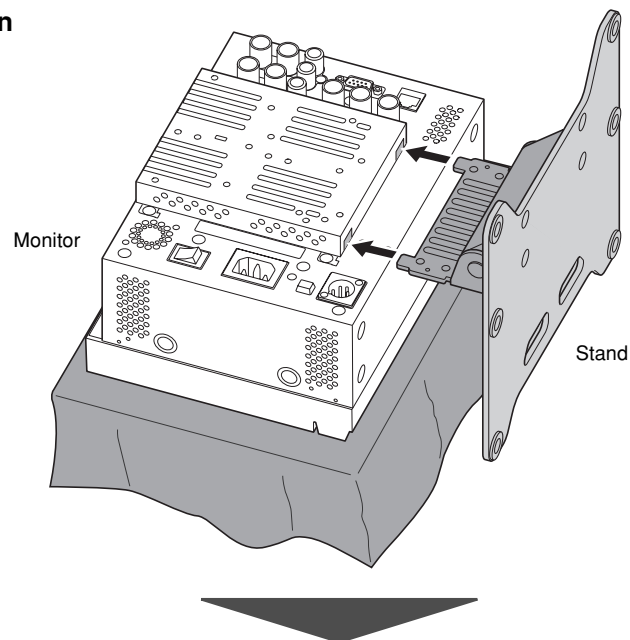

Lower position

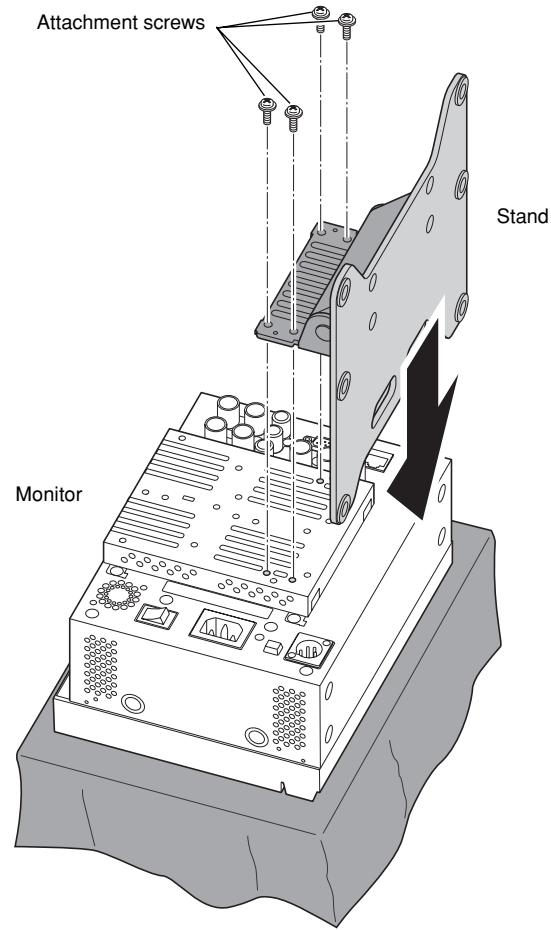

To prevent an accidental fall

Fix the monitor to a wall by using strings.

Fixing the monitor

Attach the hook (not provided) to the VESA mounting holes on the rear panel (use the two 100 mm pitch holes on the upper side) using M4 x 10 mm screws (not provided). Bind the hooks on the rear panel of the monitor to a wall or a pillar using durable string.

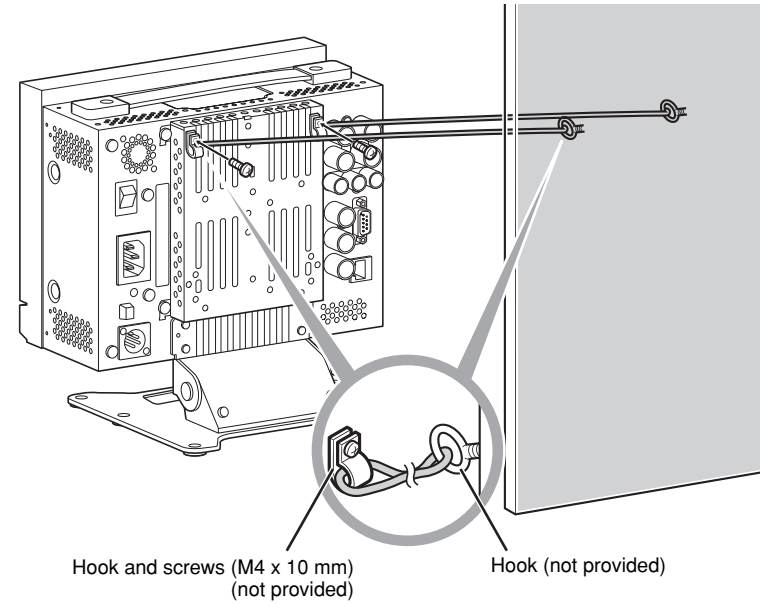

■ Front panel

Tally lamp

This lamp is controlled by the tally function of the MAKE/TRIGGER terminal.

- This lamp can also be used as the format indicator (☞ “FORMAT INDICATOR” in “FUNCTION SETTING” on page 14).

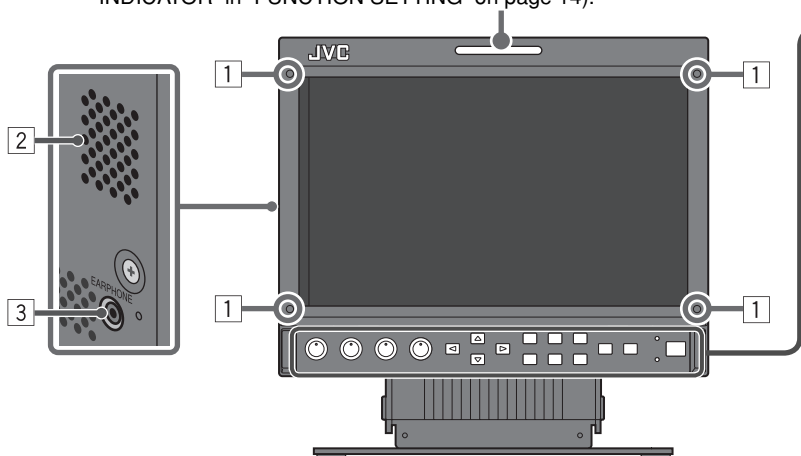

1 Screw holes for attaching protective filter (provided)

- Attach the protective filter by using the provided screws.
- Attach the filter to the LCD panel with the frosted side of the filter facing outwards (when shipped from the factory, a protective film and a sticker are attached to the frosted side).

CAUTION

- Use only the provided screws to avoid damaging the monitor.
- When attaching the protective filter, do not fasten screws too tightly; otherwise, the protective filter may be damaged.

2 Speaker (monaural)

The speaker emits the same audio signal as emitted from the AUDIO (MONITOR OUT) OUT 1 terminal. (☞ “9 AUDIO (MONITOR OUT) terminals” on page 8)

3 EARPHONE (earphones) jack (monaural)

Connect earphones to this jack to listen to the same sound as produced from the speaker.

4 Picture adjustment knob

PHASE: Adjusts the picture hue.

CHROMA: Adjusts the picture color density.

BRIGHT: Adjusts the picture brightness.

CONTRAST: Adjusts the picture contrast.

5 MUTING button

Turns off the sound when no menu screen is displayed.

- To cancel the function, press the button again or press VOL. +/- buttons.

6 ◀/▶/△/▽ buttons

When a menu screen is displayed

Selects or adjusts menu items. (☞ “Menu Operations” on page 7)

When no menu screen is displayed

Selects the audio channels of EMBEDDED AUDIO signals, or adjusts the volume. (☞ “Audio Channel Selection” on page 7)

- Pressing ◀ button while holding ▽ button displays the SET-UP MENU. (☞ “Menu Operations” on page 7)

7 SCR. CHK. (Screens check) button/lamp

Displays only the selected element (R, G, B, or the luminance) of video signal.

- Each time you press this button, the screen changes in the following order.

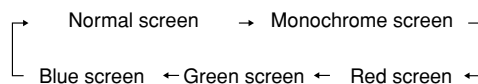

- “NO EFFECT” is displayed when you press a button which is not available for the current input or signal format (the lamp lights even when the function does not actually work).
- The items controlled by the MAKE system cannot be controlled by the buttons on the front panel (“REMOTE ON” is displayed and the lamps do not light).

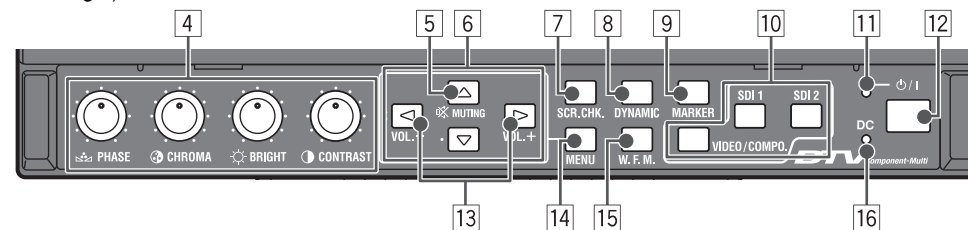

8 DYNAMIC button/lamp

Adjusts the picture to be suitable for a bright place.

- When the DYNAMIC lamp lights:
 - “BACK LIGHT” and “PICTURE SUB ADJ.” are not displayed on the menu.
 - The setting of “BACK LIGHT” is ineffective. (☞ page 10, 14)

9 MARKER button/lamp

Displays/hides the area marker and the safety marker.

- Select the size and the style of the markers in “MARKER” of the MAIN MENU (☞ page 11).
- The marker is not displayed when it is set to “OFF” in “MARKER.” (☞ “NOTE” on page 11)

10 Input select buttons/lamps

Selects an input.

VIDEO/COMPO.: VIDEO/COMPONENT terminal

SDI 1: E. AUDIO HD/SD SDI (IN 1) terminal

SDI 2: E. AUDIO HD/SD SDI (IN 2) terminal

- The lamp for the selected input lights.
- Select an appropriate setting of “VIDEO/COMPO. SEL.” (☞ page 10).

11 Power lamp

Unlit: The monitor is completely off (both the POWER switch and DC switch on the rear panel are turned off).

Lights in green: The monitor is on.

Lights in orange: The monitor is off (on standby).

Flashes in orange: The monitor is in the P. SAVE (power save) mode (☞ “NO SYNC ACTION” in “SYNC FUNCTION” on page 13).

12 ⏻ / I button

Turns on and off (on standby) the monitor.

- The power switches (the POWER switch and DC switch) are equipped on the rear panel of the monitor (☞ 1, 3 on page 8).
- To turn off the monitor completely, turn off the POWER switch and DC switch.

13 VOL. +/- buttons

Adjusts the volume.

14 MENU button

Activates/deactivates the display of the MAIN MENU. (☞ “Menu Operations” on page 7)

15 W. F. M. (Wave form monitor) button/lamp

Displays/hides the indication of the wave form monitor.

- Adjust the settings of the wave form monitor in “WAVE FORM SETTING” of the MAIN MENU (☞ page 13).
- Closed captions (☞ page 13) disappear when the wave form monitor is displayed.

16 DC lamp

When the DC 12 V power voltage is being lowered due to the battery consumption, the lamp changes to orange from green. When the voltage becomes lower than a certain level, the monitor automatically turns off and the lamp turns to red.

- Make sure to turn off the POWER switch and DC switch on the rear panel before replacing the battery.
- The length of time that the lamp lights in orange differs depending on the type of battery or the battery condition. It is recommended to replace the battery when the lamp turns to orange.

Menu Operations

1 Display the menu.

To display the **MAIN MENU**

➔ Press MENU button.

To display the **SET-UP MENU**

➔ Press ◀ button while holding ▽ button.

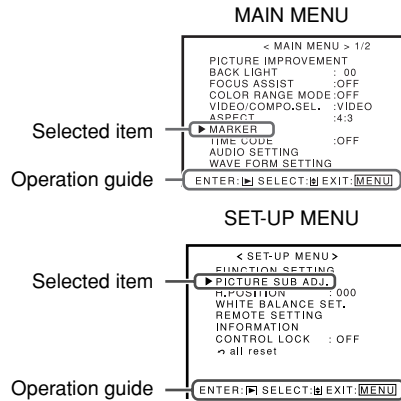

2 Press △ ▽ buttons to select an item, then press ▷ button.

• For some items, adjustments will be made by pressing ◀▷.

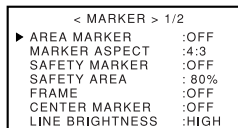

Ex.: When "MARKER" in the MAIN MENU is selected

3 Press △ ▽ buttons to select an item, then press ◀▷ buttons to make adjustments.

4 Press MENU button to finish the menu operation.

• Pressing MENU button repeatedly deactivates the display of the menu.

Audio Channel Selection

Select audio channels emitted from the speaker and the AUDIO (MONITOR OUT) OUT1/OUT2 terminals, when EMBEDDED AUDIO signals come in to the E. AUDIO HD/SD SDI terminal (IN1 or IN2) and SDI input (1 or 2) is selected.

- The speaker emits the same audio signal emitted from the AUDIO (MONITOR OUT) OUT 1 terminal.
- The setting is memorized for each input (SDI 1 and SDI 2).

1 Press ◀ or ▷ button when a menu is not displayed.

The screen for audio channel selection is displayed.

- The screen for audio channel selection automatically disappears in about 30 seconds after the previous operation.

Audio channel selection screen

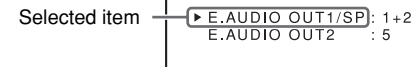

2 Press △ ▽ buttons to select the channel to set.

- E.AUDIO OUT1/SP:
AUDIO (MONITOR OUT) OUT1 terminal and the speaker.
- E.AUDIO OUT2:
AUDIO (MONITOR OUT) OUT2 terminal.

3 Press ◀▷ buttons to select an audio channel.

Each time you press the button, the audio channel changes as follows:
 1/2/3/4/5/6/7/8/9/10/11/12/1+2/3+4/5+6/7+8/
 9+10/11+12/1G(1-4)/2G(5-8)/3G(9-12)/
 1G+2G(1-8)/1-3G(1-12)

4 Press MENU button.

The screen for audio channel selection disappears.

On the Information Display

The monitor displays the information below depending on the settings of the menu.

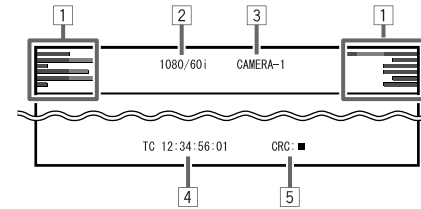

1 Audio level meter

- Not displayed when no signal comes in for the SDI inputs or "LEVEL METER ch" is set to "OFF."

☞ "AUDIO SETTING" and "NOTE" on page 12

2 Signal format

- Displayed when "STATUS DISPLAY" is set to "ON." (☞ "INFORMATION" on page 15)
- For the contents displayed, see "On the signal format" below and "Available signals" on page 9.

3 Source name assigned in "CHARACTER SET."

- Displayed when "SOURCE ID" is set to "ON."
- Displayed in large letters when "STATUS DISPLAY" is set to "OFF" or "AUTO."

☞ "INFORMATION" on page 15

4 Time code

- Displayed when "TIME CODE" is set to "ON." (☞ "TIME CODE" on page 11)
- When the input signal includes no time code, "TC --:--:--:--" is displayed.

5 CRC error indication

- Displayed when "CRC ERROR" is set to "ON." (☞ "INFORMATION" on page 15)
- A red square is displayed when an error occurs.

On the Status Display

If you press the input button of the current input, the status of the input signal and setting of muting are displayed for about 3 seconds.

- Make the setting to display/hide the status in "STATUS DISPLAY" of the "INFORMATION" (☞ page 15).
- When "STATUS DISPLAY" is set to "AUTO" or "ON," the status below is also displayed in the following cases:
 - When you change the input
 - When the signal condition of the current input changes
 - When you turn on the monitor
- When "STATUS DISPLAY" is set to "ON," the signal format will remain displayed 3 seconds after the status is displayed.

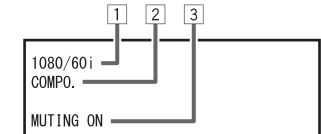

1 Signal format

- For the contents displayed, see "On the signal format" below and "Available signals" on page 9.

2 Setting of "VIDEO/COMPO. SEL.,"

☞ page 10

3 Setting of "MUTING"

- Displayed only when muting is activated.
- ☞ "MUTING" button" on page 6

On the signal format

The following messages appear depending on the type of input signals and their conditions.

When no video signal comes in

➔ "NO SYNC"

When a noncompliant video signal comes in

➔ "Out of range"

When "COLOR SYSTEM" (☞ "FUNCTION SETTING" on page 14) is set to "AUTO" and the noncompliant composite video signals come in

➔ "OTHERS"

Rear panel

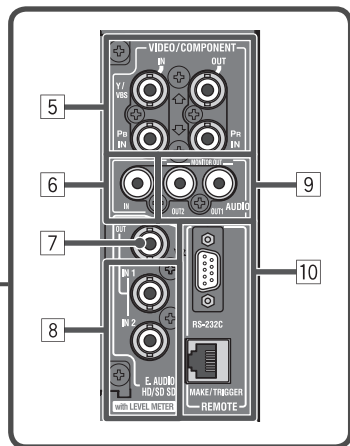
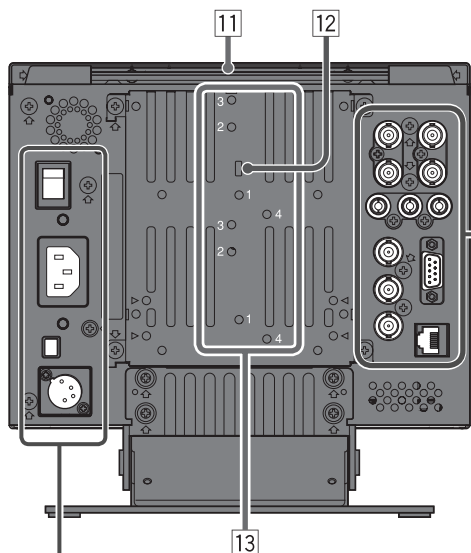

1 POWER switch

Turns AC power on or off.
 • You need to press / button (see 12 on page 6) to use the monitor after turning on the POWER switch.

2 AC IN terminal

AC power input connector.
 Connect the provided AC power cord to an AC outlet.
 • Attach the provided power cord holder to prevent accidental disconnection of the AC power cord (see "Attaching the Power Cord Holder" on page 9).

3 DC switch

Turns the DC 12 V power on or off.
 • You need to press / button (see 12 on page 6) on the front panel to turn on the monitor after turning on the DC switch.
 • The monitor consumes the battery even while the monitor is on standby. To save battery life, turn off the DC switch.

4 DC IN terminal

DC 12 V (maximum DC 17 V) power input connector.
 • While using both the AC and DC 12 V power supply, AC power supply is preferentially used. If the AC power supply is cut off (for example, when turning off the POWER switch), the power supply automatically switches to the DC 12 V power supply.

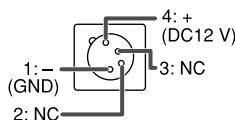

5 VIDEO/COMPONENT terminals (BNC)

IN: Input terminals for the composite (VBS) and the analog component (Y/P_B/P_R) signals.

- Select the signal type in "VIDEO/COMPO. SEL." corresponding to the type of the input signal (see page 10).

OUT: Output terminal for the composite (VBS) and the analog component (Y) signals.

6 AUDIO IN terminal (pin jack)

Input terminal for the analog audio signals.
 • Use this terminal for the analog audio connection of the SDI.

7 E. AUDIO HD/SD SDI (SWITCHED OUT) terminal (BNC)

Output terminal for the HD/SD SDI signals.
 • The SDI signals of the current input (SDI 1 or SDI 2) are re-clocked, then emitted.
 • When an input other than SDI 1 and SDI 2 is selected, the SDI signal of the input selected last time is emitted from this terminal.
 • The signals are emitted from this terminal only when the monitor is on or in "P.SAVE" (power save) mode.

8 E. AUDIO HD/SD SDI (IN 1, IN 2) terminals (BNC)

Input terminals for the HD/SD SDI signals.
 • The terminals accept also EMBEDDED AUDIO signals including up to 12 audio channels with a sampling frequency of 48 kHz.

9 AUDIO (MONITOR OUT) terminals (pin jack)

Output terminals for the analog audio signal.
 • The terminals emit the audio signals coming in from the AUDIO IN terminal or EMBEDDED AUDIO signals coming in from the E. AUDIO HD/SD SDI (IN 1 or IN 2) input terminal. (see "Audio Channel Selection" on page 7)
 • The signal is output from these terminals only when the monitor is on or in "P.SAVE" (power save) mode. (see "NO SYNC ACTION" in "SYNC FUNCTION" on page 13)
 • The EMBEDDED AUDIO signal...
 – is decoded into an analog signal, then emitted.
 – is emitted only when "SDI 1" or "SDI 2" is selected, and when EMBEDDED AUDIO signals come in to the E. AUDIO HD/SD SDI (IN 1 or IN 2) terminal.

10 REMOTE terminals

Terminals for controlling the monitor by an external control. (see "External Control" on page 16)

11 Carry handle

Use this handle when carrying the monitor.

12 Security slot

Attach a security wire to this slot.

13 Screw holes for external battery attachment

Attach external battery for DC 12 V power supply by using 2 screw holes. Choose the appropriate screw holes from 1, 2, 3 or 4, according to the type of external battery.
 • Use the Anton Bauer Dionic 90 (mount: QR DXC-M3A) external battery.

CAUTION

- Do not use the external battery for DC 24 V power supply.
- Use only the battery specified above. If a heavy battery is used, it may fall off depending on the way the monitor is used.

Note for connections

- Before making any connections, turn off all the equipment.
- Use a cord whose plugs correctly match the terminals on this monitor and the equipment.
- Plugs should be firmly inserted; poor connections could cause noise.
- When unplugging a cord, be sure to grasp its plug and pull it out.
- DO NOT connect the power cord until all connections are complete.
- Refer also to the user manual of each piece of equipment.

CAUTION

Do not connect the power cord until all other connections are completed.

When using DC 12 V power (maximum DC 17 V), check the DC IN terminal pin signal, and use the correct polarity. If the polarity is reversed, this could cause a fire or personal injury.

■ Available signals

The following signals are available for this monitor.

Video signals

No.	Signal name	Signal format shown in the status display (see page 7)	Input terminal		E. AUDIO HD/ SD SDI*1
			VIDEO/COMPONENT		
			VBS (Composite)	Y/Pb/Pr (Analog component)	
1	NTSC*2	NTSC	√	—	—
2	PAL	PAL	√	—	—
3	B/W50	PAL	√	—	—
4	B/W60*2	NTSC	√	—	—
5	480/60i	480/60i	—	√	—
6	480/59.94i*2	480/59.94i	—	√	√
7	576/50i	576/50i	—	√	√
8	480/60p	480/60p	—	√	—
9	480/59.94p	480/59.94p	—	√	—
10	576/50p	576/50p	—	√	—
11	720/60p	720/60p	—	√	√
12	720/59.94p	720/59.94p	—	√	√
13	720/50p	720/50p	—	√	√
14	1080/60i	1080/60i	—	√	√
15	1080/59.94i	1080/59.94i	—	√	√
16	1035/60i	1080/60i	—	√*3	√*3
17	1035/59.94i	1080/59.94i	—	√*4	√*4
18	1080/50i	1080/50i	—	√	√
19	1080/30psF	1080/60i	—	√*3	√*3
20	1080/25psF	1080/50i	—	√*5	√*5
21	1080/29.97psF	1080/59.94i	—	√*4	√*4
22	1080/24psF	1080/24psf	—	√	√
23	1080/23.98psF	1080/23.98psf	—	√	√

√: Acceptable

—: Not acceptable

*1 Compatible with EMBEDDED AUDIO signals

*2 When the number of vertical scanning lines of the incoming signal is 483, the picture is displayed with 480 lines.

*3 The signal is recognized as 1080/60i.

*4 The signal is recognized as 1080/59.94i.

*5 The signal is recognized as 1080/50i.

- Analog component signals are compatible with Y on sync signals.

Attaching the Power Cord Holder

The provided power cord holder prevents accidental disconnection of the AC power cord from the AC IN terminal.

- The power cord holder consists of two parts, a case and a cover.

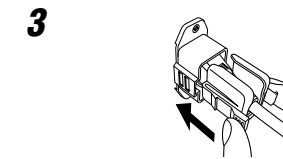
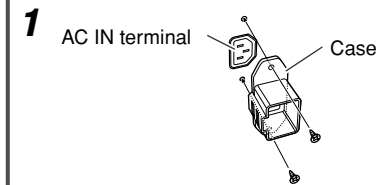

CAUTION

Use only the provided screws.

CAUTION

Make sure the plug will not be pulled out after the cover is attached to the case.

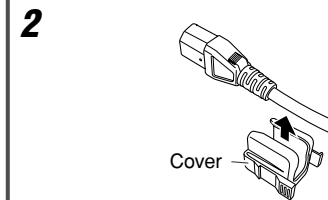

To detach the cover

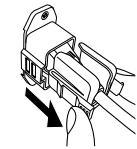

For the operation procedure, see page 7.

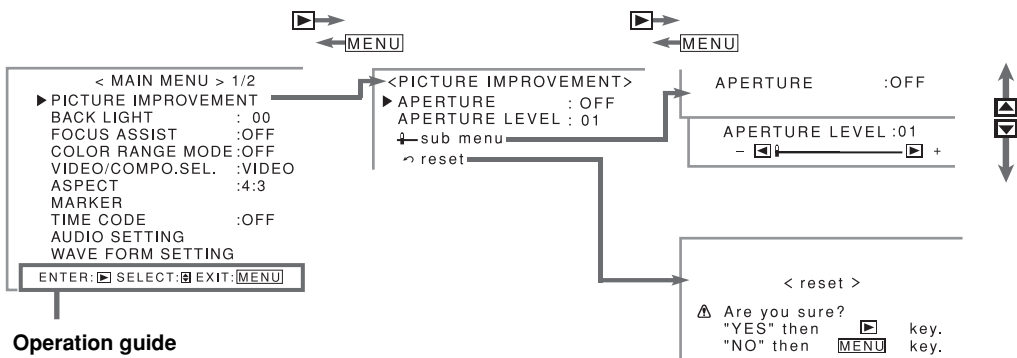

Operation guide
Shows the buttons for each operation.

- The menu automatically disappears in about 30 seconds after the previous operation.
- Some items may not appear on the menu depending on the input or the input signal.
- The items controlled by the MAKE system do not appear on the menu.

PICTURE IMPROVEMENT

Setting for the picture quality

Item	To do	Setting value
APERTURE*	Select the frequency of the luminance signal compensated in "APERTURE LEVEL."	OFF, LOW, HIGH
APERTURE LEVEL*	Compensate the frequency response of the luminance signal of the video signal.	01 – 10
sub menu	Display the sub menu which enables you to adjust the items of "PICTURE IMPROVEMENT" while viewing the actual picture.	
reset	Restore the default settings for all the items in "PICTURE IMPROVEMENT."	

BACK LIGHT Setting value: -20 – +20

Adjusts the brightness of the display.

- When the DYNAMIC lamp lights, this item does not appear on the menu (see [8] on page 6).

FOCUS ASSIST Setting value: OFF, ON

Helps to focus the picture.

- When "ON" is selected,
 - "PICTURE IMPROVEMENT" is not displayed on the menu.
 - The settings of "PICTURE IMPROVEMENT" are ineffective.

COLOR RANGE MODE Setting value: OFF, ON

Reduces the difference of the luminance level specific to the LCD panel.

- When "ON" is selected, the color temperature becomes the innate temperature in the LCD panel, and the setting of "WHITE BALANCE SET." becomes ineffective (see page 14).

VIDEO/COMPO. SEL. Setting value: VIDEO, COMPO. (component)

Selects the signal type you want to use for the VIDEO/COMPONENT terminals.

- When select the component (COMPO.), make sure to set the component level in "COMPO. LEVEL" in "PICTURE SUB ADJ." (see page 14).

ASPECT* Setting value: 4:3, 16:9

Changes the aspect ratio of the picture.

* Memorized for each input — composite signal input (VIDEO), component signal input (COMPO.), SDI 1 and SDI 2.

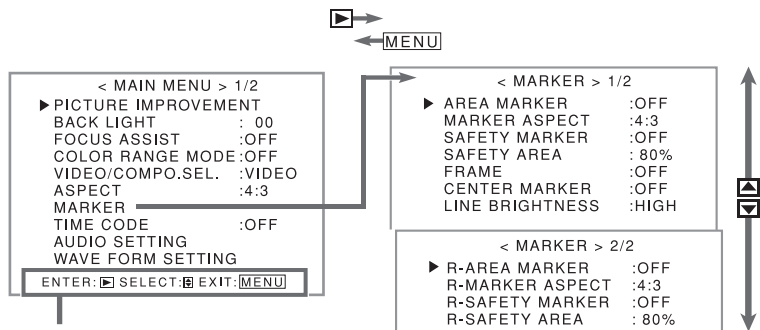

Operation guide
Shows the buttons for each operation.

- The menu automatically disappears in about 30 seconds after the previous operation.
- Some items may not appear on the menu depending on the input or the input signal.
- The items controlled by the MAKE system do not appear on the menu.

NOTE

Setting of “AREA MARKER”, “SAFETY MARKER”, “R-AREA MARKER”, “R-SAFETY MARKER”

The setting values and features are as follows.

- OFF:** Deactivate the marker.
- LINE:** Displays the area with an outline.
- HALF:** The area outside the specified aspect ratio of the screen is displayed at 50% transparency.
- HALF+L:** The area of the specified aspect ratio of the screen is indicated by an outline, and the area outside of that is displayed at 50% transparency.
- BLK.:** The area outside the specified aspect ratio of the screen is black. Only the portion of the picture within the designated area is displayed.
- BLK. +L:** The area of the specified aspect ratio of the screen is indicated by an outline, and the area outside of that becomes black so that only the area inside the line is displayed.

MARKER*1

Settings for marker functions

1/2

Item	To do	Setting value
AREA MARKER*2	Activate/deactivate the area marker and select the style of it.	☞ “NOTE”
MARKER ASPECT*2	Select the aspect ratio of the area marker.	4:3, 14:9, 13:9, 2.35:1, 1.85:1, 1.66:1
SAFETY MARKER	Activate/deactivate the safety marker and select the style of it.	☞ “NOTE”
SAFETY AREA	Adjust the area of the safety marker.	80% – 100%
FRAME*3	Displays/hides the frame indicating the area of the specified aspect ratio.	OFF, ON
CENTER MARKER	Displays/hides the marker indicating the center position of the picture.	OFF, ON
LINE BRIGHTNESS	Adjust the brightness of the marker.	HIGH, LOW

2/2

Item	To do	Setting value
R-AREA MARKER*2	Activate/deactivate the area marker and select the style of it.	☞ “NOTE”
R-MARKER ASPECT*2	Select the aspect ratio of the area marker.	4:3, 14:9, 13:9, 2.35:1, 1.85:1, 1.66:1
R-SAFETY MARKER	Activate/deactivate the safety marker and select the style of it.	☞ “NOTE”
R-SAFETY AREA	Adjust the area of the safety marker.	80% – 100%

- The area marker and the safety marker is displayed by using MARKER button or external control.
- Select either non-“R-” items or “R-” items to activate by using external control (☞ “External Control” on page 16).
- When a picture is displayed in 4:3 aspect ratio, the safety marker for the 4:3 area is displayed.
- To display the safety marker for the area of a picture displayed in 16:9 aspect ratio, hide the area marker. (☞ “NOTE”)

*1 Memorized for each input — composite signal input (VIDEO), component signal input (COMPO.), SDI 1 and SDI 2.

*2 Displayed only when picture is displayed in 16:9 aspect ratio.

*3 For signals of NTSC, B/W60, 480/60i and 480/59.94i, only the vertical borders of the frame are displayed.

TIME CODE Setting value: OFF, ON

Activates/deactivates the display of the time data (time code) contained in the SDI signal.

(☞ “On the Information Display” on page 7)

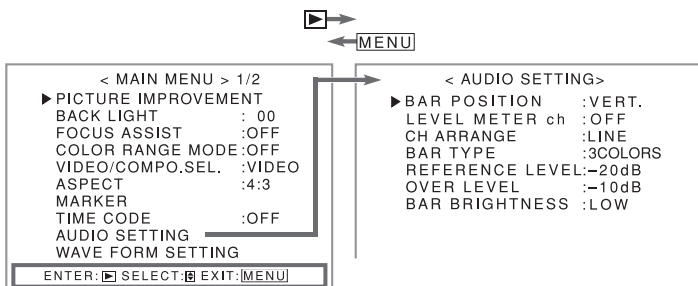

Operation guide
Shows the buttons for each operation.

- The menu automatically disappears in about 30 seconds after the previous operation.
- Some items may not appear on the menu depending on the input or the input signal.
- The items controlled by the MAKE system do not appear on the menu.

AUDIO SETTING

Settings for the level meter

Item	To do	Setting value
BAR POSITION	Select the type of the level meter display — vertically or horizontally.	VERT. (vertically), HORZ. (horizontally)
LEVEL METER ch	Select the number of the audio channels displayed on the level meter.	OFF, 12CH, 8CH
CH ARRANGE	Select the order of the audio channels displayed on the level meter.	LINE, DIVIDE (≡ “NOTE”)
BAR TYPE	Select the color of the level meter display.	3COLORS (3 colors to indicate variations in input levels), W.100 (white), W.50 (half tone)
REFERENCE LEVEL	Select the standard input level indicated on the level meter.	-20dB, -18dB
OVER LEVEL	Select the input level's lower limit indicated in red for the “3COLORS” display.	-10dB, -8dB, -6dB, -4dB, -2dB
BAR BRIGHTNESS	Select the brightness of the level meter.	LOW, HIGH

NOTE

Example of the level meter display—Level meter position and audio channels

Ex.: When “LEVEL METER ch” is set to “8CH” and “BAR TYPE” is set to “3COLORS.”

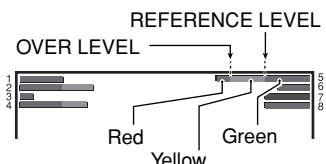

Ex.: BAR POSITION: HORZ.,
CH ARRANGE: LINE

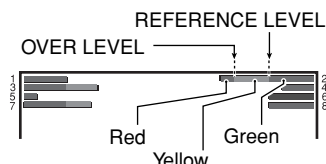

Ex.: BAR POSITION: HORZ.,
CH ARRANGE: DIVIDE

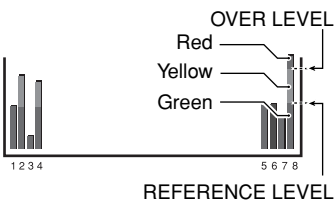

Ex.: BAR POSITION: VERT.,
CH ARRANGE: LINE

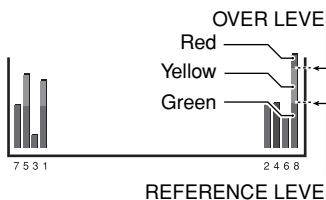

Ex.: BAR POSITION: VERT.,
CH ARRANGE: DIVIDE

- When “CH ARRANGE” is set to “DIVIDE,” odd channels are displayed on the left and even channels are displayed on the right.
- When “BAR TYPE” is set to “W.100” or “W.50,” the standard input level set in the “REFERENCE LEVEL” is displayed with the line indication. The input level set in “OVER LEVEL” is not displayed.
- The level meter with no signal input is displayed in white for “3COLORS,” and in gray for “W.100” or “W.50.”

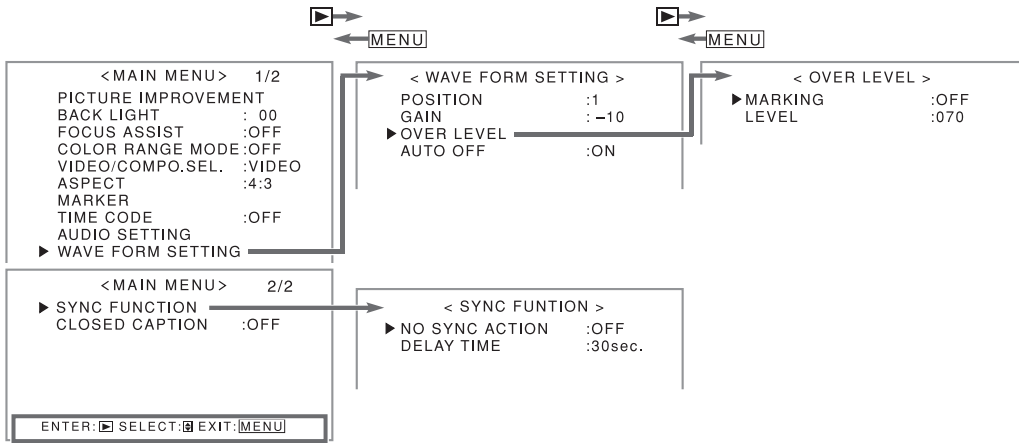

Operation guide

Shows the buttons for each operation.

- The menu automatically disappears in about 30 seconds after the previous operation.
- Some items may not appear on the menu depending on the input or the input signal.
- The items controlled by the MAKE system do not appear on the menu.

NOTE

Example of the wave form monitor

Ex.: When "MARKING" is set to "ON" and "LEVEL" is set to "080"

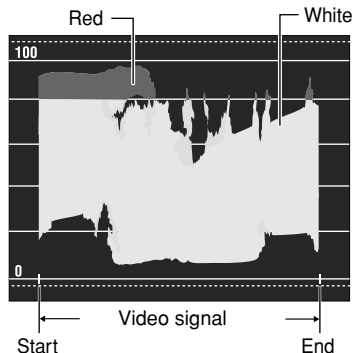

- The wave which goes over the value set on "LEVEL" is indicated in red.

WAVE FORM SETTING

Settings for the wave form monitor

Item	To do	Setting value
POSITION	Select the position of the wave form monitor.	1 (lower right), 2 (lower left), 3 (upper left), 4 (upper right)
GAIN	Adjust the gain level for the incoming wave form data.	-10 - +10
OVER LEVEL	Select the over level for the incoming luminance signals.	☞ "NOTE"
MARKING	Activates/deactivates the function to change the color of a wave form when the signal exceeds the limit specified on "LEVEL" (☞ below).	OFF, ON
LEVEL	Adjust the lower limit for the luminance signal	070 -109
AUTO OFF	Activates/deactivates the function to make the wave form monitor indication go off automatically 15 minutes after displaying it.	ON, OFF

SYNC FUNCTION

Settings for the synchronization with signals

Item	To do	Setting value
NO SYNC ACTION	Select the screen status when no signal is coming in.	OFF, P.SAVE (power save mode), GRAY B. (gray screen)
DELAY TIME	Select the period until the screen status changes as selected in "NO SYNC ACTION" after signals stop coming in.	30sec., 5min., 15min.

- When setting "NO SYNC ACTION" to "GRAY B.," the screen color changes to gray and the power consumption of the back light is saved by half. Selecting "P.SAVE" (power save mode) saves more power consumption by turning off the back light.

CLOSED CAPTION Setting value: OFF, CC1, CC2

Selects the type of closed caption for analog composite signals (NTSC and B/W60 only).

- Regardless of the setting, the closed caption is not displayed when the wave form monitor is displayed.

For the operation procedure, see page 7.

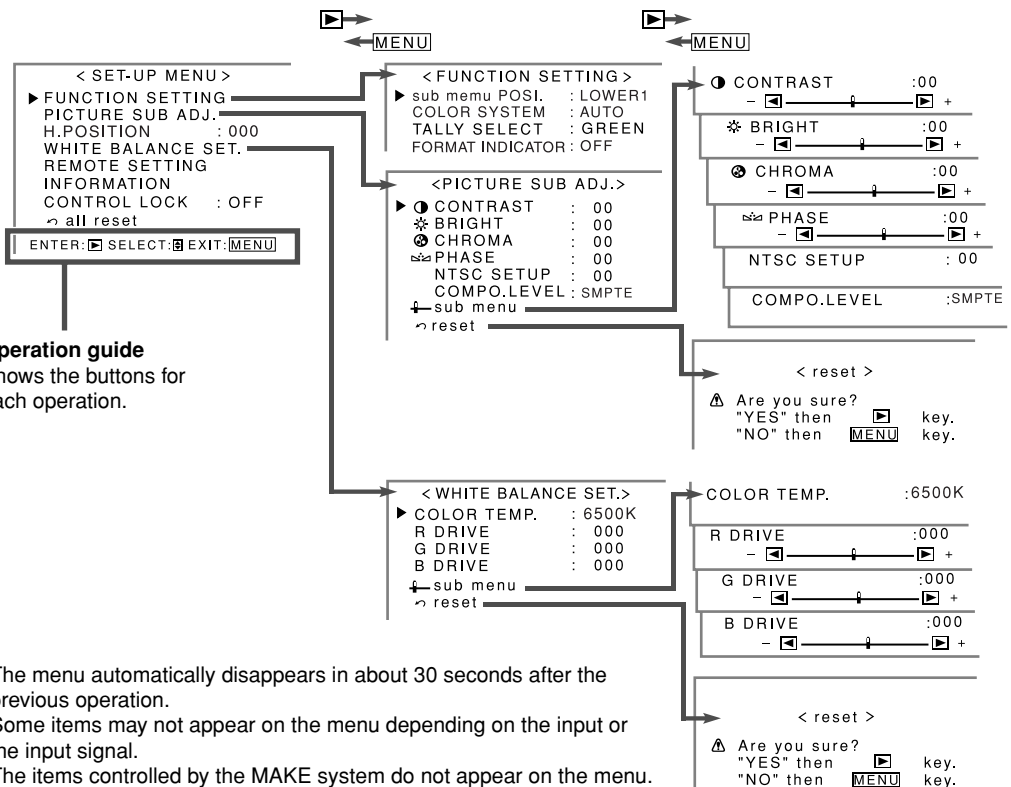

Operation guide
Shows the buttons for each operation.

- The menu automatically disappears in about 30 seconds after the previous operation.
- Some items may not appear on the menu depending on the input or the input signal.
- The items controlled by the MAKE system do not appear on the menu.

NOTE

Settings of “sub menu POSI.”

The setting values and features are as follows.

- LOWER1:** Displays the current setting and adjustment bar at the lower part of the screen.
- UPPER1:** Displays the current setting and adjustment bar at the upper part of the screen.
- LOWER2:** Displays the current setting at the lower part of the screen.
- UPPER2:** Displays the current setting at the upper part of the screen.

- The adjustment bar is not displayed for some items.

Color of the format indicator

When “FORMAT INDICATOR” is set to “ON,” the tally lamp lights as follows according to the incoming video signal.

Lights in green: 720/60p, 720/59.94p, 720/50p, 1080/60i, 1080/59.94i, 1080/50i, 1035/60i, 1035/59.94i, 1080/24psF, 1080/23.98psF, 1080/30psF, 1080/25psF, 1080/29.97psF

Lights in red: 480/60i, 480/59.94i, 576/50i, 480/60p, 480/59.94p, 576/50p

Lights in orange: composite signal

- The lamp goes off when the non-compliant video signals are coming in.

FUNCTION SETTING

Settings for the sub menu display, color system, color of the tally lamp, and the format indicator.

Item	To do	Setting value
sub menu POSI.	Select the contents and displaying position of “sub menu.”	Ⓜ “NOTE”
COLOR SYSTEM	Select the color system. • If the picture is unstable with “AUTO,” select “NTSC” or “PAL.”	AUTO, NTSC, PAL
TALLY SELECT	Select the color of the tally lamp.	GREEN, RED
FORMAT INDICATOR	Select whether to use the tally lamp as the format indicator.	OFF, ON (Ⓜ “NOTE”)

- When “FORMAT INDICATOR” is set to “ON,” the TALLY function of the MAKE/TRIGGER terminal is not available.

PICTURE SUB ADJ.

Adjusts the standard level for the picture adjustment and selects the set-up level for the input video signal.

Item	To do	Setting value
CONTRAST*†	Adjust the standard level for the contrast adjusted with CONTRAST knob on the front panel.	-20 – +20
BRIGHT*†	Adjust the standard level for the brightness adjusted with BRIGHT knob on the front panel.	-20 – +20
CHROMA*†	Adjust the standard level for the chroma adjusted with CHROMA knob on the front panel.	-20 – +20
PHASE*†	Adjust the standard level for the phase adjusted with PHASE knob on the front panel.	-20 – +20
NTSC SETUP	Select the set-up level of the input NTSC signal.	00 (compliant with 0% set-up signal), 7.5 (compliant with 7.5% set-up signal)
COMPO. LEVEL	Select the level of the analog component signal (480i and 576i only).	B75 (compliant with BetacamVTR 7.5% set-up signal), B00 (compliant with BetacamVTR 0% set-up signal), SMPTE (compliant with M2VTR signals)
sub menu	Display the sub menu which enables you to adjust the items in “PICTURE SUB ADJ.” while viewing the actual picture.	
reset	Restore the default settings for all the items in “PICTURE SUB ADJ.”	

- When the DYNAMIC lamp lights, “PICTURE SUB ADJ.” does not appear on the menu (Ⓜ [8] on page 6).

H. POSITION*† Setting value: -003 – +003

Adjusts the horizontal picture position.

WHITE BALANCE SET.

Selects the color temperature and adjusts the drive level of each color (R/G/B).

Item	To do	Setting value
COLOR TEMP.	Select the color temperature.	9300K, 6500K, USER
R DRIVE, G DRIVE, B DRIVE*‡	Adjust the drive level of each color (red, green, and blue).	MIN – 000 – MAX (in 256 grades)
sub menu	Display the sub menu which enables you to adjust the items in “WHITE BALANCE SET.” while viewing the actual picture.	
reset	Restore the default settings for the drive levels of the selected color temperature.	

- When “COLOR RANGE MODE” is set to “ON,” “WHITE BALANCE SET.” does not appear on the menu (Ⓜ page 10).

*† Memorized for each input — composite signal input (VIDEO), component signal input (COMPO.), SDI 1 and SDI 2.

*‡ Memorized for each color temperature.

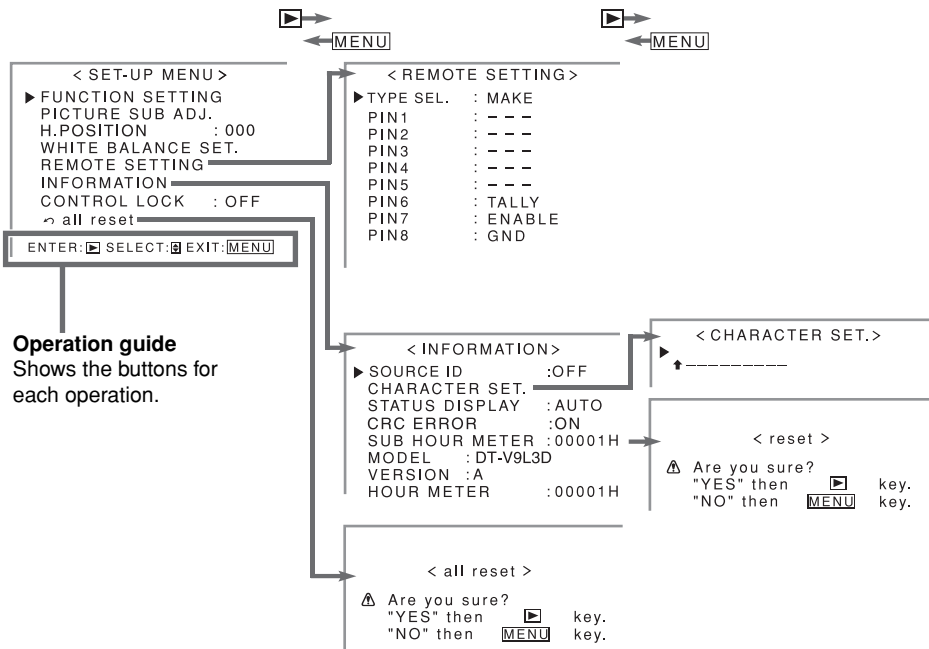

Operation guide
Shows the buttons for each operation.

- The menu automatically disappears in about 30 seconds after the previous operation.
- Some items may not appear on the menu depending on the input or the input signal.
- The items controlled by the MAKE system do not appear on the menu.

NOTE

Setting of "CHARACTER SET."

Assign a name for each video source.

- 1 Change the input to one that you want to assign a video source name for.
 - You cannot store different video source names for composite signal input (VIDEO) and component signal input (COMPO.).
- 2 Select "CHARACTER SET."
- 3 Press Δ ∇ buttons to select the first character.
 - Each time you press Δ button, the character changes as follows. Press ∇ button to reverse the order.

→ Space → 0 - 9 → A - Z → a - z → &() * +, - / : < > _
- 4 Press \triangleright button to move the arrow to the next space.
 - The characters entered before moving the arrow are memorized.
- 5 Repeat steps 3 and 4 (10 characters at maximum).
- 6 Press MENU button to store the name.



REMOTE SETTING (External Control) on pages 16, 17)

Settings for the external control

Item	To do	Setting value
TYPE SEL.	Select the external control method for the MAKE/TRIGGER terminal.	MAKE, TRIGGER, SET
PIN1, PIN2, PIN3, PIN4, PIN5	Assign the control functions to the pins of the MAKE/TRIGGER terminal. <ul style="list-style-type: none"> • Assign a function to each pin terminal by selecting "SET" in "TYPE SEL." mentioned above. (The functions are assigned for "PIN6" – "PIN8" and you cannot change the assignment of these functions.) 	TALLY SEL, SDI 1, SDI 2, VIDEO/COMPO., MARKER, FRAME, C.MARKER, MARK.SEL, ASPECT, STATUS, L.METER, TIME CODE, SOURCE ID, WAVE FORM, C. C., COLOR OFF, SCR CHECK, DYNAMIC, FOCUS ASSIST, COLOR RANGE, MUTING, --- (no function)

INFORMATION

Settings for the information display of the monitor

Item	To do	Setting value
SOURCE ID	Select if the name assigned in "CHARACTER SET." is displayed on the screen (External Control "On the Information Display" on page 7).	OFF, ON
CHARACTER SET.	Assign a name to each video source as you like (10 characters at maximum). You can also enter a name using the RS-232C system.	External Control "NOTE"
STATUS DISPLAY	Select if the status of the current input and the setting of muting are displayed on the screen (External Control "On the Status Display" on page 7).	AUTO, OFF, ON
CRC ERROR	Select if the CRC error indication for the input HD SDI signal is displayed on the screen (External Control "On the Information Display" on page 7).	ON, OFF
SUB HOUR METER	Display the hours of use (unit: hour). You can reset this item.	
MODEL	Display the model name of the monitor.	
VERSION	Display the version of the monitor.	
HOURL METER	Display the total hours of use (unit: hour). This item is used for maintenance of the monitor. You cannot reset this item.	

CONTROL LOCK Setting value: OFF, ON

Turns on (or off) the control lock function to disable the buttons on the front panel.

- The following operations are available even when this function is activated.
 - Turning on/off (on standby) the monitor
 - Displaying the SET-UP MENU (by pressing \triangleleft button while holding ∇ button) and turning "CONTROL LOCK" to "OFF"
 - Operating the monitor by an external control
- If you try other operations, "Control lock on!" appears on the screen.

all reset

Restores all the settings and adjustments of the monitor to the default.

- "HOURL METER" and the settings done by using the adjustment knobs on the front panel will not be reset.
- When you operate the monitor with the AC power supply, the monitor is turned off (on standby) then turned on automatically. When you operate the monitor with the DC 12 V power supply, the monitor is turned off (on standby).

About the external control

This monitor has two external control terminals.

- **MAKE/TRIGGER terminal (RJ-45):** The following external control systems are available.
 - (1) **MAKE (make contact) system:** Controls the monitor by short-circuiting the corresponding pin terminal to the GND pin terminal, or disconnecting (opening) it (see below).
 - (2) **TRIGGER (trigger) system:** Controls the monitor by sending the pulse signal instantaneously to the corresponding pin terminal (see below).
- **RS-232C terminal (D-sub 9-pin):** Controls the monitor with the RS-232C system. (see page 17)
- Control priority is as follows.
 - MAKE > TRIGGER, RS-232C, buttons and menu on the monitor**
- You can use the external control even when "CONTROL LOCK" is set to "ON" (see page 15).
- When the monitor is off (on standby), external control is not available.

Using the MAKE/TRIGGER system

You can control the monitor by a personal computer or dedicated controller*1.

*1 The controller is not commercially available. Consult your dealer if you need it.

The MAKE/TRIGGER terminal is configured as follows. You can assign a function to each pin terminal in "REMOTE SETTING" (see "PIN1, PIN2, PIN3, PIN4, PIN5" on page 15).

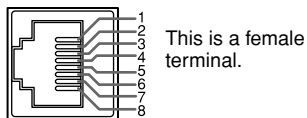

Pin No.	Pin name	Pin No.	Pin name
1	PIN1	5	PIN5
2	PIN2	6	PIN6 (TALLY)*2
3	PIN3	7	PIN7 (ENABLE)*3
4	PIN4	8	PIN8 (GND)

*2 The 6th pin terminal controls turning on or off the tally lamp (available to control even when the 7th pin terminal is invalid.)

*3 The 7th pin terminal makes the external control valid/invalid. Make sure to control the terminal by the MAKE system.

- You cannot change the functions assigned to the pin terminals from 6th to 8th.
- When "FORMAT INDICATOR" in "FUNCTION SETTING" is set to "ON," the TALLY lamp cannot be controlled by the external control (see page 14)
- You cannot assign the same function to different pin terminals.
- The TRIGGER system switches each function by short-circuiting the pin terminal for about 1 second and opening it.

To assign the functions to the pin terminals

For the operation procedure, see page 7.

- 1 Select "REMOTE SETTING" on the SET-UP MENU.
- 2 Set "TYPE SEL." to "SET."
- 3 Select a pin name ("PIN1" – "PIN5") for which you want to assign a function, then select the function you want to assign.
 - For selectable functions, see the table on the right.

Functions controlled by the MAKE/TRIGGER system

Display	Functions to be controlled	Opening	Short-circuiting
TALLY SEL	Selects the color of the tally lamp.	Green	Red
SDI 1	Changes the input to "SDI 1."	Invalid	Valid
SDI 2	Changes the input to "SDI 2."	Invalid	Valid
VIDEO/COMPO.	Changes the input to "VIDEO/COMPO."	Invalid	Valid
MARKER	The area marker and the safety marker indication	Off	On
FRAME	Indication of the area of the specified aspect ratio	Off	On
C.MARKER	The center marker indication	Off	On
MARK.SEL	Selects the items of "MARKER"*4	Non-"R-" items	"R-" items
ASPECT	Changes the aspect ratio.	4:3	16:9
STATUS	Status display*5	see "On the Status Display" on page 7	
L.METER	Audio level meter display	*6	
TIME CODE	Time code display	Off	On
SOURCE ID	see "SOURCE ID" on page 15	Off	On
WAVE FORM	Wave form monitor display*7	Off	On
C. C.	Closed caption display	*8	
COLOR OFF	Color off	Color	Monochrome
SCR CHECK	Screens check	*9	
DYNAMIC	Adjusts the picture to be suitable for a bright place.	Off	On
FOCUS ASSIST	Helps to focus the picture.	Off	On
COLOR RANGE	Reduces the difference of the luminance level specific to the LCD panel.	Off	On
MUTING	Muting on/off	Off	On
— — —	No function	—	—

*4 Selects which functions in "MARKER" are activated, non-"R-" items or "R-" items (see page 11).

*5 Displays the information shown when the button of the current input is pressed (see "On the Status Display" on page 7). While controlling with the MAKE system, the information is displayed only at the moment of short-circuiting.

*6 While controlling with the MAKE system, the level meter is switched between displayed (short-circuiting) and hidden (opening). When "LEVEL METER ch" is set to "OFF," the level meter is not displayed ("NO EFFECT" appears). While controlling with the TRIGGER system, the number of the audio channels displayed is changed (between OFF, 12CH and 8CH).

*7 While controlling with the MAKE system, the wave form monitor will not disappear until opening the terminal even when "AUTO OFF" is set to "ON."

*8 For analog composite signals (NTSC and B/W60 only). While controlling with the MAKE system, the closed caption is switched between displayed (short-circuiting) and hidden (opening). When "CLOSED CAPTION" is set to "OFF," the closed caption is not displayed ("NO EFFECT" appears). While controlling with the TRIGGER system, the type of the closed caption can be selected.

*9 While controlling with the MAKE system, the screen is switched between normal screen (opening) and blue screen (short-circuiting). While controlling with the TRIGGER system, the screen changes as follows:

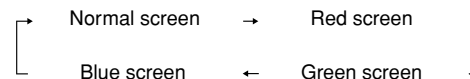

Operation of the external control

- 1 Set "TYPE SEL." of "REMOTE SETTING" to "MAKE" or "TRIGGER" in the SET-UP MENU.
 - 2 Short-circuit the 7th pin terminal (ENABLE) to the 8th pin terminal (GND) so that the monitor can be controlled by the external control.
 - 3 When the "MAKE" system is selected: Operate each function by short-circuiting the corresponding pin terminal to the 8th pin terminal (GND) or opening it.
When the "TRIGGER" system is selected: Operate each function by pulse control, that is short-circuiting the corresponding pin terminal to the 8th pin terminal (GND) for about 1 second and opening it.
- When changing the input with MAKE system, only one pin terminal must be short-circuited. (Other pin terminals must be opened.)
 - When selecting the TRIGGER system, you can operate only one function at a time. Operate the functions one by one.

Using the RS-232C system

You can control the monitor from a personal computer etc. via the RS-232C terminal.

- Consult your dealer for the details of the external control specification.

<Communication specifications>

Baud Rate: 4800 bps

Data Bits: 8 bits

Parity: No parity

Stop Bits: 1 bit

Flow Control: No control

Communication Code: ASCII Code

- Use a straight cable with a D-sub 9-pin connector (male for the monitor, female for the personal computer).

<Command outline>

All commands consist of the following segments.

Header	Monitor ID (00)	Command ID	Function	Data	Cr (0Dh)
--------	-----------------	------------	----------	------	----------

Header

"!": Operation commands from the personal computer, etc. For details, see <Basic command list> on the right.

"?": Reference commands from the personal computer, etc.

"@": Status returns from the monitor

- To start communication, send the connection command from the personal computer etc.
- To terminate the communication, send the termination command from the personal computer etc.

Example of communication procedures

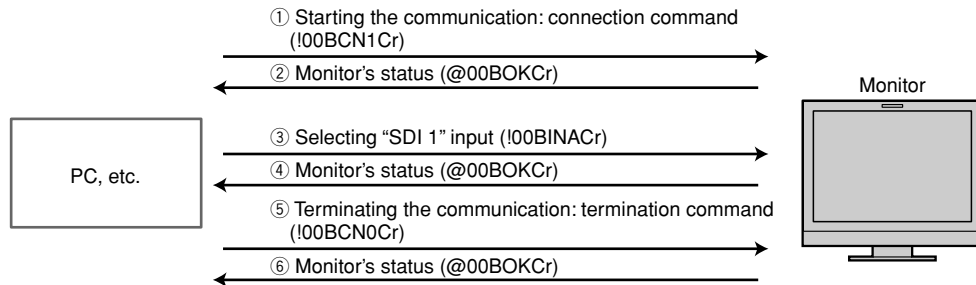

<Basic command list>

No.	Commands	Functions	Data
1	! 0 0 B C N 1 Cr	Starts communication (connection)	No data
2	! 0 0 B C N 0 Cr	Terminates communication (termination)	No data
3	! 0 0 B M E N U Cr	Displays the MAIN MENU/Quits the menu operation	No data
4	! 0 0 B U P Cr	Moves the cursor upward (Δ)	No data
5	! 0 0 B D O W N Cr	Moves the cursor downward (∇)	No data
6	! 0 0 B A D J R Cr	Makes setting/adjustment (▷)	No data
7	! 0 0 B A D J L Cr	Makes setting/adjustment (◁)	No data
8	! 0 0 B S E T U P Cr	Displays the SET-UP MENU	No data
9	! 0 0 B P W 1 Cr	Turns on the monitor	No data
10	! 0 0 B P W 0 Cr	Turns off the monitor (standby)	No data
11	! 0 0 B I N A Cr	Selects "SDI 1" input	No data
12	! 0 0 B I N B Cr	Selects "SDI 2" input	No data
13	! 0 0 B I N C Cr	Selects "VIDEO/COMPO." input	No data
14	! 0 0 B D I S P Cr	Displays the status*2	No data
15	! 0 0 B V P L S Cr	Increases the volume level	No data
16	! 0 0 B V M N S Cr	Decrease the volume level	No data
17	! 0 0 B V O L x x*1 Cr	Adjusts the volume level	00 – 30
18	! 0 0 B A M U T E x x*1 Cr	Turns muting on/off	00: Off, 01: On
19	! 0 0 B A S P x x*1 Cr	Changes the aspect ratio	00: 4:3, 01: 16:9

• "Cr" is 0Dh.

- The commands for starting communication (connection) (No. 1), terminating communication (termination) (No. 2), and turning on the monitor (No. 9) can be used while the monitor is off (on standby).

*1 Enter the appropriate data to "xx".

*2 Displays the information shown when the button of the current input is pressed (☞ "On the Status Display" on page 7).

<Specifications of the RS-232C terminal>

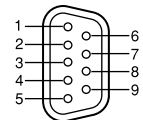

This is a female terminal.

Pin No.	Signal
1	NC
2	RXD
3	TXD
4	NC
5	GND
6	NC
7	RTS
8	CTS
9	NC

- The 7th terminal and the 8th terminal are connected.

Solutions to common problems related to the monitor are described here. If none of the solutions presented here solve the problem, unplug the monitor and consult an authorized dealer or service center.

Symptom	Probable cause and corrective action	Page
No power supply	• Press the  button.	6
	• Turn on the POWER switch or DC switch on the rear panel.	8
	• Firmly insert the AC power plug or DC 12 V power plug.	8
	• When using a DC 12 V power supply, charge the battery or replace it with a charged one.	8
No picture with the power on	• Select the correct input.	6
	• Connect the signal cable firmly.	8
	• Turn on the power of the connected component and set the output correctly.	—
	• Check whether the input signal format is acceptable on the monitor.	9
No sound	• Adjust the volume level.	6
	• Deactivate the muting function.	6
	• Connect the signal cable firmly.	8
	• Turn on the power of the connected component and set the output correctly.	—
“OTHERS” or “Out of range” appears.	• Check whether the input signal format is acceptable on the monitor.	7, 9
“NO SYNC” appears.	• Select the correct input.	6
	• Connect the signal cable firmly.	8
	• Turn on the power of the connected component and output video signals. Or, check whether the video output of the component (video output setting of the VCR) is set correctly.	—
Wrong color, no color	• Adjust each picture adjustment knob on the front panel or adjust the items of “PICTURE SUB ADJ.” in the SET-UP MENU. Or, perform “reset” in “PICTURE SUB ADJ.”	6, 14
	• Check if the screen mode is other than normal screen, by using SCR. CHK. button.	6
	• Select the proper color system (“COLOR SYSTEM”) in “FUNCTION SETTING” of the SET-UP MENU.	14
	• Adjust the items of “WHITE BALANCE SET.” in the SET-UP MENU. Or, perform “reset” in “WHITE BALANCE SET.”	14

Symptom	Probable cause and corrective action	Page
The picture becomes blurred.	• Adjust the picture contrast or brightness by using the adjustment knobs on the front panel. Or, adjust “CONTRAST” or “BRIGHT” of “PICTURE SUB ADJ.” in the SET-UP MENU.	6, 14
Wrong picture position, wrong picture size.	• Check whether the input signal format is acceptable on the monitor.	7, 9
	• Check the setting of “ASPECT” in the MAIN MENU.	10
Some items do not appear on the menu.	• Adjust the horizontal picture position in “H. POSITION” of the SET-UP MENU.	14
	• For some signals, the picture cannot be displayed fully in the effective screen area. There is no sure method to solve this problem.	—
Buttons on the monitor do not work.	• The items which are not available for the current input or the current input signal are not displayed on the menu. Change the input or the input signal.	—
	• The items controlled by the MAKE system do not appear on the menu.	16
Buttons on the monitor do not work.	• Set “CONTROL LOCK” in the SET-UP MENU to “OFF.”	15
	• You cannot use the buttons for the items controlled by the MAKE system. Disable the external control.	16

The following are not malfunctions.

- When a still image is displayed for a long time, it may remain indistinctly on the screen after the picture has changed. Though the remaining picture will disappear after a while, there may be a case that it remains for a long period depending on the length of time the still image was displayed for. This is due to the characteristics of the LCD display and is not a malfunction.
- Red spots, blue spots and green spots on the panel surface are a normal characteristic of LCD displays, and not a problem. The LCD display is built with very high precision technology; however, be aware that a few pixels may be missing or constantly lit.
- The following symptoms are problems only when pictures or sounds are not played back normally.
 - A slight electric shock occurs when you touch the monitor.
 - The top and/or rear panel of the monitor becomes hot.
 - The monitor emits a cracking noise.
 - The monitor emits a mechanical noise.

■ Self-check program

This monitor has a self-check function, which allows it to detect malfunctions and alert you. This makes troubleshooting easier. Whenever a problem occurs, one or some of the self-check lamps will flash. If this happens, follow the steps below and contact your dealer to resolve the problem.

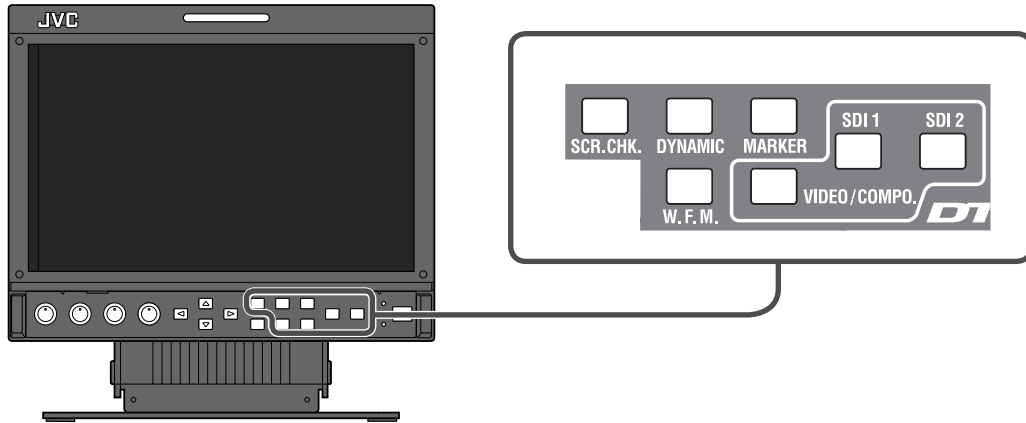

When the screen goes blank and one or some of the self-check lamps on the front control panel start flashing...

- 1 Check which lamps are flashing.**
- 2 Press \odot /I button to turn off (on standby) the monitor.**
- 3 Turn off the POWER switch and DC switch on the rear panel.**
- 4 When the AC power supply is used: Disconnect the AC power cord from the AC outlet.**
When a DC 12 V power supply is used: Detach the battery or disconnect the plug from the DC IN terminal.
- 5 Contact your dealer with the information about which lamps were flashing.**

- If you turn on the monitor soon after turning it off (or after a short-term power failure), the self-check lamps may flash and no image may be displayed. When this happens, turn off power and wait at least 10 seconds before turning on the monitor again. If the self-check lamps do not flash, you can use the monitor as normal.

Unplug this product from the wall outlet before cleaning.

Screen

To avoid irreparable change in appearance of the screen such as uneven color, discoloration, scratches, be careful about the following:

- Do not paste or stick anything using any glues or adhesive tapes.
- Do not write anything on the screen.
- Do not strike the screen with a hard object.
- Avoid condensation on the screen.
- Do not wipe the screen with solvent such as alcohol, thinner, or benzine.
- Do not wipe the screen forcefully.

Wipe stains off the screen with a soft cloth. If the screen gets heavily stained, wipe it with a soft cloth soaked in water-diluted neutral detergent and wrung well, then wipe with a soft dry cloth.

Cabinet

To avoid the deterioration or damages of the cabinet such as its paint's peeling away, be careful about the following:

- Do not wipe the cabinet using solvent such as alcohol, thinner, or benzine.
- Do not expose the cabinet to any volatile substance such as insecticides.
- Do not allow any rubber or plastic in contact for a long time.
- Do not wipe the cabinet forcefully.

Wipe stains off the cabinet with a soft cloth. If the cabinet gets heavily stained, wipe it with a soft cloth soaked in water-diluted neutral detergent and wrung well, then wipe with a soft dry cloth.

Ventilation openings

Use a vacuum cleaner to get rid of the dust around the intakes (all the openings). If a vacuum cleaner is not available, use a cloth and wipe it off. Leaving the dust around the intakes may prevent proper temperature control and cause damage to the product.

Specifications

■ General

Model name	DT-V9L3DY
Type	Multi format LCD monitor
Screen size	Type 9 wide format
Aspect ratio	15:9
LCD panel	9" wide, IPS-Pro
Effective screen size	Width: 195 mm (7 5/8") Height: 117 mm (4 9/16")
Number of pixels displayed	800 x 480
Number of colors displayed	16.77 million
Viewing angle (TYP.)	170° (Horizontally), 170° (Vertically)
Brightness	350 cd/m ²
Contrast ratio (TYP.)	400:1
Compliant video signal format	☞ "Available signals" on page 9
Format	HD SDI: BTA S-004B, SMPTE292M SD SDI: ITU-R BT.656: 525/625 SMPTE259M: 525 EMBEDDED AUDIO: SMPTE299M, SMPTE272M
Audio output	Internal speaker: 1.0 W
Operating conditions	Operating temperature: 0°C – 40°C (32°F – 104°F) Operating humidity: 20 % – 80 % (non-condensing) * Slightly variable depending on ambient conditions for installation.
Power requirements	AC 120 V, 50 Hz/60 Hz DC 12 – 17 V
Rated current	0.35 A (AC 120 V) 1.7 A (DC 12 – 17 V)
External dimensions (excluding protruding parts)	Width: 222.4 mm (8 7/8") Height: 218 mm (8 5/8") (at the higher position), 181 mm (7 1/4") (at the lower position), 176 mm (7") (without stand) Depth: 185 mm (7 3/8") (at the higher position), 202 mm (8") (at the lower position), 116 mm (4 5/8") (without stand)
Weight	3.6 kg (7.9 lbs) (with the stand) 2.7 kg (5.9 lbs) (without the stand)
Accessories	AC power cord x 1, Power cord holder x 1, Screw x 2 (for power cord holder), Protective filter x 1, Screw (for protective filter) x 4

Use the Anton Bauer Dionic 90 (mount: QR DXC-M3A) external battery.

CAUTION

Danger of explosion if battery is incorrectly replaced. Replace only with the same or equivalent type.

■ Input/output terminals

Video	VIDEO/COMPONENT (IN/OUT)	VBS/Y Composite signal/analog component (Y) signal input/output: 1 line, BNC connector x 2 1 V(p-p), 75 Ω * The input (IN) and output (OUT) terminals are bridge-connected (auto termination)
	E. AUDIO HD/SD SDI (IN 1)	P _B , P _R Analog component (P _B , P _R) signal input: 1 line, BNC connector x 2 0.7 V(p-p), 75 Ω
	E. AUDIO HD/SD SDI (IN 2)	
Audio	E. AUDIO HD/SD SDI (SWITCHED OUT)	Digital signal output (compatible with EMBEDDED AUDIO signals): 1 line switched out, BNC connector x 1
	AUDIO (IN)	Analog audio signal input: 1 line, RCA connector x 1, 500 mV (rms), high impedance
	AUDIO (MONITOR OUT)	Analog audio signal output: 1 line, RCA connector x 2, 500 mV (rms)
External control	EARPHONE	Monaural mini jack (3.5 mm in diameter) x 1
	REMOTE (MAKE/TRIGGER)	☞ "Using the MAKE/TRIGGER system" on page 16
	REMOTE (RS-232C)	☞ "Using the RS-232C system" on page 17

Notice on transportation

This monitor is precision equipment and needs dedicated packing material for transportation. Never use any packing material supplied from sources other than JVC or JVC-authorized dealers.

- For easy understanding, pictures and illustrations are shown by being emphasized, omitted or composed, and may be slightly different from actual products.
- Design and specifications are subject to change without notice.
- All company names and product names mentioned herein are used for identification purposes only, and may be the trademarks or registered trademarks of their respective companies.

■ Dimensions Unit: mm (inch)

<Front view>

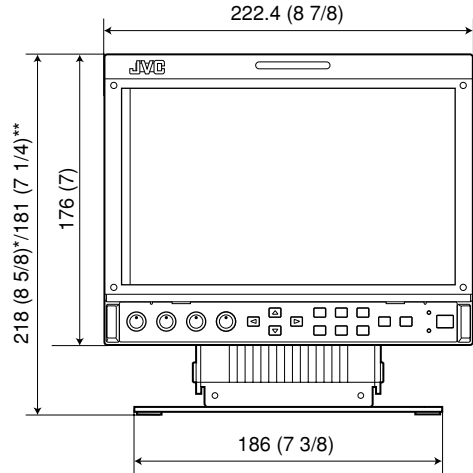

* at the higher position
** at the lower position

<Side view>

- When the stand is attached to the higher position.

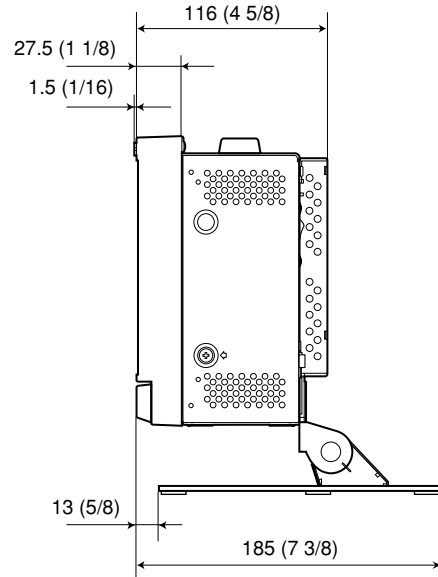

- When the stand is attached to the lower position.

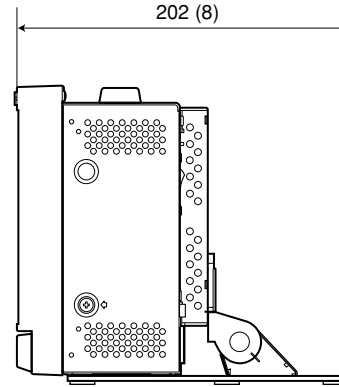

<Rear view>

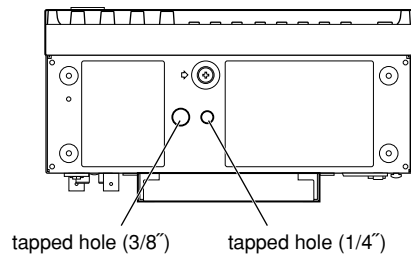
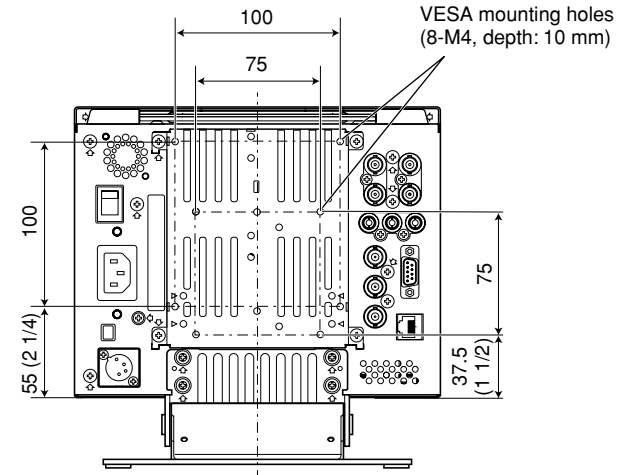

JVC