

**BLODGETT**® **BLODGETT**® **BLODGETT**® **BLODGETT**®

**BLODGETT**® **BLODGETT**® **BLODGETT**®

**BLODGETT**® **BLODGETT**® **BLODGETT**® **BLODGETT**®

---

**BLODGETT**®

**MARK V XCEL  
CONVECTION OVEN  
INSTALLATION – OPERATION – MAINTENANCE**



**BLODGETT OVEN COMPANY**

[www.blodgett.com](http://www.blodgett.com)  
44 Lakeside Avenue, Burlington, Vermont 05401 USA Telephone (800) 331-5842, (802) 860-3700 Fax: (802)864-0183

PN 36433 Rev C (2/05)  
© 2003 – G.S. Blodgett Corporation

# IMPORTANT

**WARNING: IMPROPER INSTALLATION, ADJUSTMENT, ALTERATION, SERVICE OR MAINTENANCE CAN CAUSE PROPERTY DAMAGE, INJURY OR DEATH. READ THE INSTALLATION, OPERATING AND MAINTENANCE INSTRUCTIONS THOROUGHLY BEFORE INSTALLING OR SERVICING THIS EQUIPMENT**

## **FOR YOUR SAFETY**

**Do not store or use gasoline or other flammable vapors or liquids in the vicinity of this or any other appliance.**

**The information contained in this manual is important for the proper installation, use, and maintenance of this oven. Adherence to these procedures and instructions will result in satisfactory baking results and long, trouble free service. Please read this manual carefully and retain it for future reference.**

**Errors: Descriptive, typographic or pictorial errors are subject to correction. Specifications are subject to change without notice.**



***THE REPUTATION YOU CAN COUNT ON***

For over a century and a half, The Blodgett Oven Company has been building ovens and nothing but ovens. We've set the industry's quality standard for all kinds of ovens for every foodservice operation regardless of size, application or budget. In fact, no one offers more models, sizes, and oven applications than Blodgett; gas and electric, full-size, half-size, countertop and deck, convection, Cook'n Hold, Combi-Ovens and the industry's highest quality Pizza Oven line. For more information on the full line of Blodgett ovens contact your Blodgett representative.

Your Service Agency's Address:



Model:

---

Serial Number:

---

Your oven was installed by:

---

Your oven's installation was checked by:

---

# Table of Contents

---

## **Introduction**

Oven Description and Specifications .....	2
---	---

## **Installation**

Delivery and Location .....	3
Oven Assembly .....	4
Sanitation Bolts .....	4
Leg Attachment .....	5
Caster Assembly .....	5
Double Section Assembly .....	6
Oven Leveling .....	6
Utility Connections – Standards and Codes .....	7
Electrical Connection .....	8
Initial Startup .....	9

## **Operation**

Safety Information .....	10
Solid State Manual Control .....	11
Solid State Digital Control .....	12
Solid State Digital Control with Humidaire .....	15
CH-Pro3 (Solid State Programmable Digital Control) .....	18
Blodgett IQ2 <sup>™</sup> Control .....	21
General Guidelines for Operating Personnel .....	30

## **Maintenance**

Cleaning and Preventative Maintenance .....	31
Troubleshooting Guide .....	32



# Introduction

## Oven Description and Specifications

Cooking in a convection oven differs from cooking in a conventional deck or range oven since heated air is constantly recirculated over the product by a fan in an enclosed chamber. The moving air continually strips away the layer of cool air surrounding the product, quickly allowing the heat to penetrate. The result is a high quality product, cooked at a lower temperature in a shorter amount of time.

Blodgett convection ovens represent the latest advancement in energy efficiency, reliability, and ease of operation. Heat normally lost, is recirculated within the cooking chamber before being vented from the oven: resulting in substantial reductions in energy consumption and enhanced oven performance.

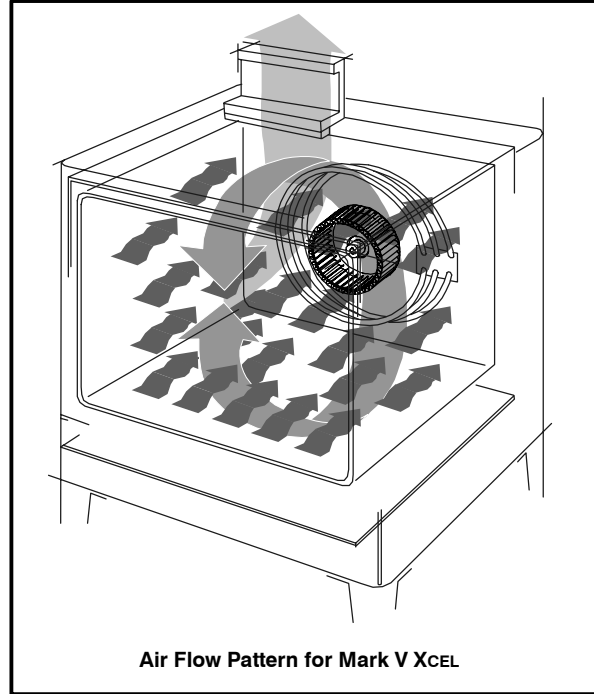

Air Flow Pattern for Mark V XCEL

Figure 1

ELECTRICAL SPECIFICATIONS (per section) – MKV1XL/AA								
KW	Hz	Volts	Phase	Amps				Electrical Connection (minimum size)
				L1	L2	L3	N	
<b>U.S. and Canadian installations</b>								
11.0	60	208	1	53	–	53	–	6 AWG
11.0	60	208	3	33	28	33	–	8 AWG
11.0	60	220-240	1	50	–	50	–	6 AWG
11.0	60	220-240	3	31	26	31	–	8 AWG
11.0	60	440	3	16	13	16	–	12 AWG
11.0	60	480	3	15	12	15	–	12 AWG
<b>General Export installations</b>								
11.0	50	220-240	1	50	–	50	–	Size per local code
11.0	50	240/415	3	19	14	14	5	Size per local code
11.0	50	230/400	3	19	14	14	5	Size per local code



### DELIVERY AND INSPECTION

All Blodgett ovens are shipped in containers to prevent damage. Upon delivery of your new oven:

- Inspect the shipping container for external damage. Any evidence of damage should be noted on the delivery receipt which must be signed by the driver.
- Uncrate the oven and check for internal damage. Carriers will accept claims for concealed damage if notified within fifteen days of delivery and the shipping container is retained for inspection.

**The Blodgett Oven Company cannot assume responsibility for loss or damage suffered in transit. The carrier assumed full responsibility for delivery in good order when the shipment was accepted. We are, however, prepared to assist you if filing a claim is necessary.**

### OVEN LOCATION

The well planned and proper placement of your oven will result in long term operator convenience and satisfactory performance.

The following clearances must be maintained between the oven and any combustible or non-combustible construction.

- Oven body right side – 0" (0 cm)
- Oven body left side – 0" (0 cm)
- Oven body back – 0" (0 cm)
- Oven body bottom – 1/2" (1.2 cm)

The following clearances must be available for servicing.

- Oven body sides – 12" (30 cm)
- Oven body back – 12" (30 cm)

It is essential that an adequate air supply to the oven be maintained to provide a sufficient flow of combustion and ventilation air.

- Place the oven in an area that is free of drafts.
- Keep the oven area free and clear of all combustibles such as paper, cardboard, and flammable liquids and solvents.
- Do not place the oven on a curb base or seal to a wall. This will restrict the flow of air and prevent proper ventilation. Tripping of the blower motor's thermal overload device is caused by an excessive ambient temperature on the right side of the oven. This condition must be corrected to prevent permanent damage to the oven.

Before making any utility connections to this oven, check the rating plate to be sure the oven specifications are compatible with the electrical services supplied for the oven.

1. Open the doors, the rating plate is located under the top edge of the oven.



# Installation

## Oven Assembly

### SANITATION BOLTS

These bolts are required by NSF to block any exposed hole on the back of an oven. This includes:

- any unit, single or stacked, without a back panel.
- any holes in stacked units not used for mounting stacking brackets.

1. Locate the 5/16" bolts that were shipped with the oven.
2. Install the bolts as shown in Figure 2.

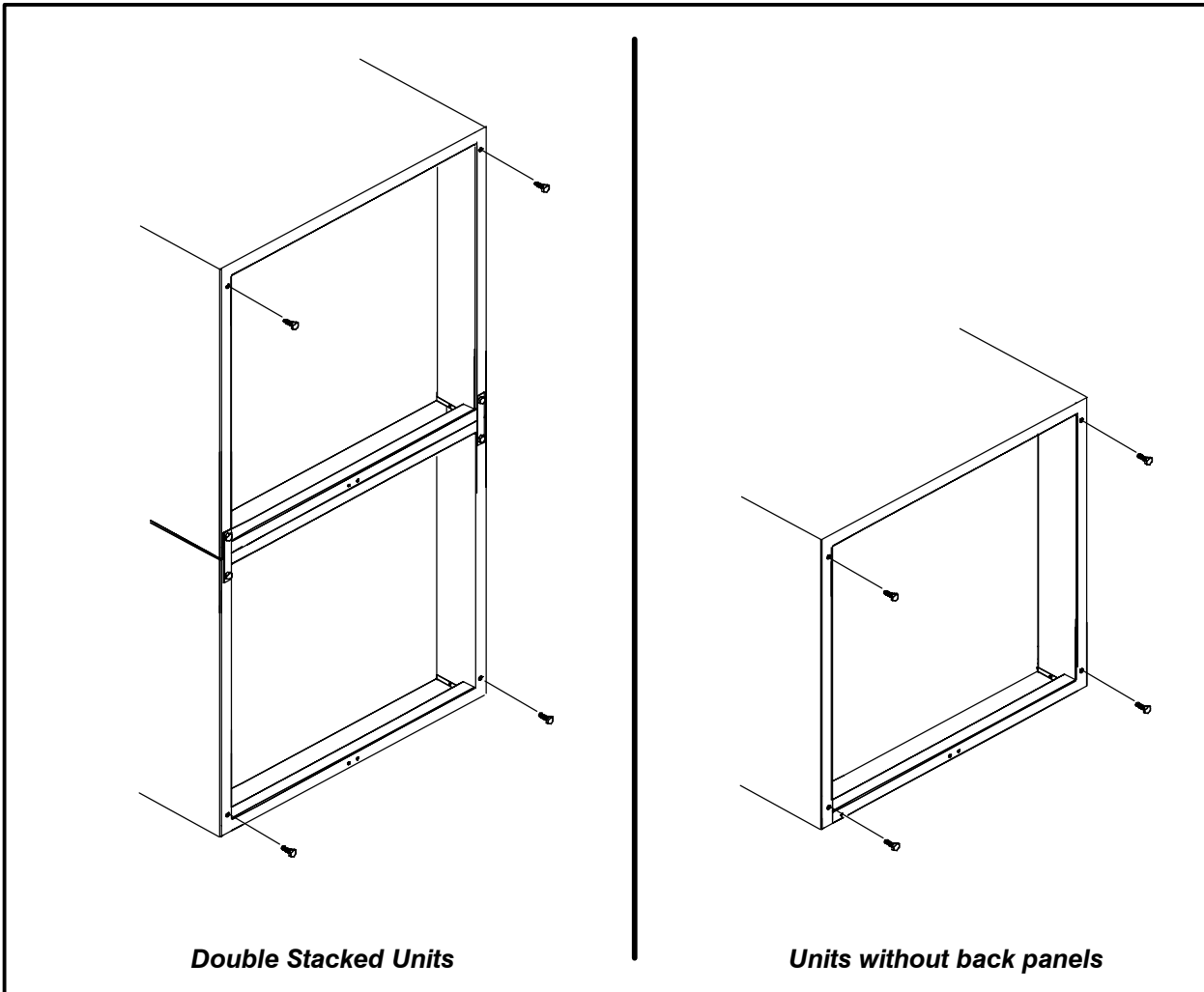

Figure 2





## Oven Assembly

### LEG ATTACHMENT

1. Lay the oven on its back.
2. Align the threaded stud in each leg with the nut located inside each bottom corner of the oven frame. Turn the legs clockwise and tighten to the nearest full turn.
3. Align the two leg plate holes in each leg with those in the oven bottom. Secure each leg using two 1/2" bolts.

*NOTE: If using casters see CASTER ASSEMBLY before proceeding.*

4. Tip the oven up on the legs.
5. Level the oven by screwing the adjustable leg feet in or out as necessary.

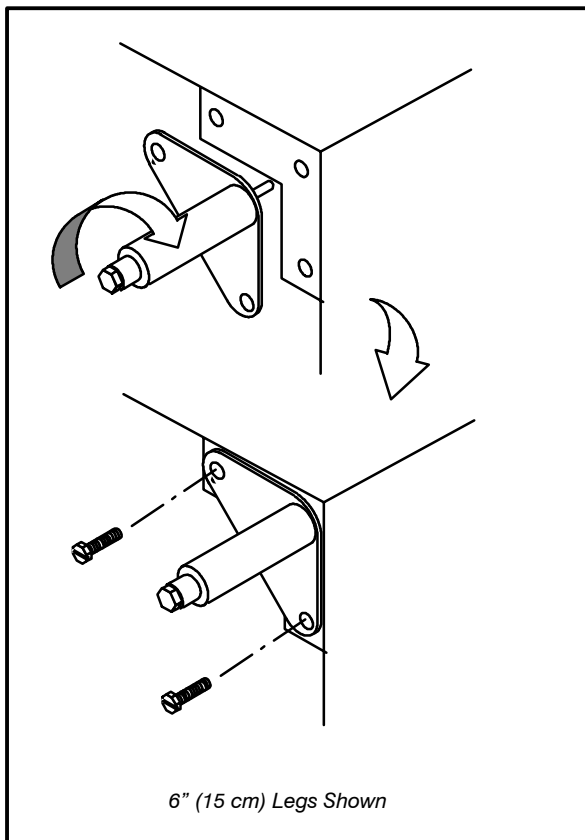

**Figure 3**

### CASTER ASSEMBLY

*NOTE: Install the locking casters on the front of the oven. Install the non-locking casters on the back of the oven.*

#### Casters for Single and Double Stacked Ovens:

1. Attach the legs as described.
2. Pry the adjustable feet out of the legs
3. Insert one caster into each leg as shown. Tighten the lock nuts to secure the casters.

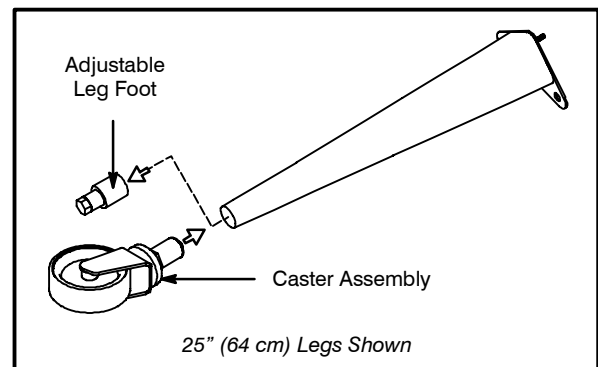

**Figure 4**

#### Low Profile Casters for Double Stacked Ovens:

1. Align the three holes in each caster assembly plate with those in the oven bottom. Secure each caster using three 1/2" bolts.

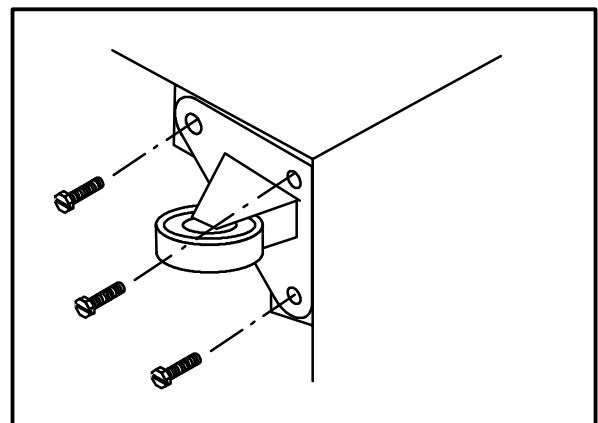

**Figure 5**



# Installation

## Oven Assembly

### DOUBLE SECTION ASSEMBLY

1. Secure the short legs to the bottom sections as described.
2. Attach lower flue box to lower oven.
3. Place the upper section in position on top of the lower oven.
4. Attach the stacking brackets using the remaining 5/16" bolts shipped with the ovens.
5. Install flue riser and attach upper flue box to upper oven.



### WARNING!!

**When stacking ovens be sure to remove the single oven flue boxes prior to attaching upper and lower boxes and riser.**

### OVEN LEVELING

After assembly, the oven should be leveled and moved to the operating location.

1. The oven can be leveled by adjusting the feet or casters located on the bottom of each leg.

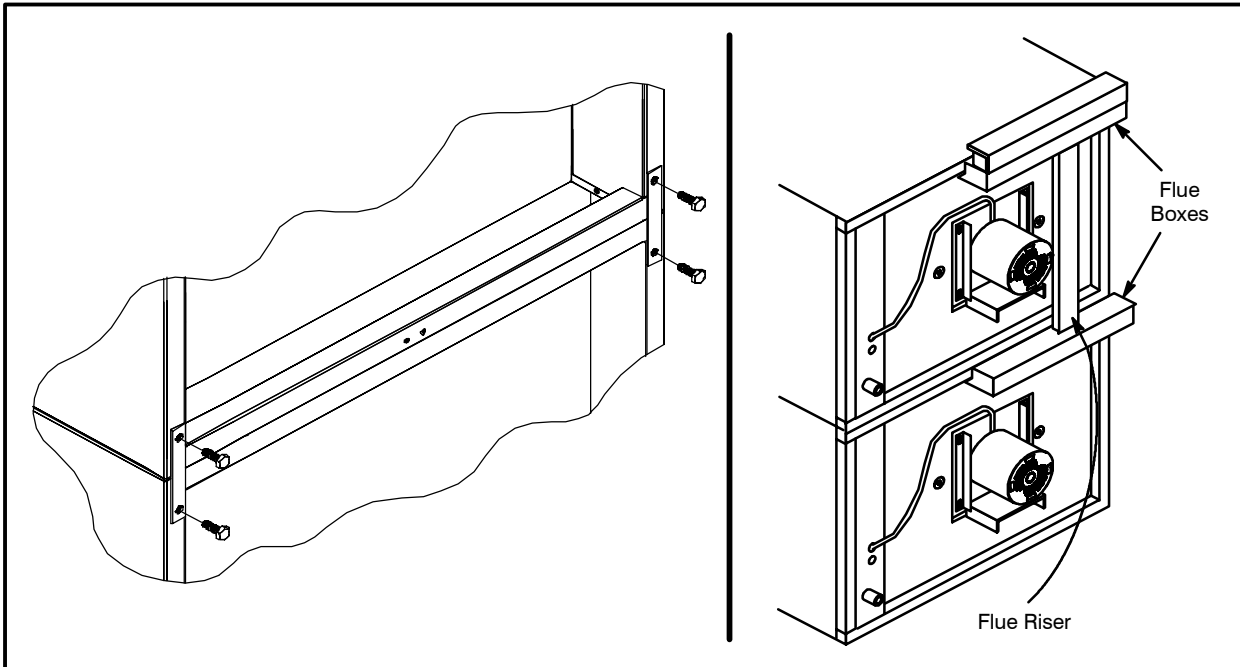

Figure 6



## Utility Connections – Standards and Codes

THE INSTALLATION INSTRUCTIONS CONTAINED HEREIN ARE FOR THE USE OF QUALIFIED INSTALLATION AND SERVICE PERSONNEL ONLY. INSTALLATION OR SERVICE BY OTHER THAN QUALIFIED PERSONNEL MAY RESULT IN DAMAGE TO THE OVEN AND/OR INJURY TO THE OPERATOR.

Qualified installation personnel are individuals, a firm, a corporation, or a company which either in person or through a representative are engaged in, and responsible for:

- the installation of electrical wiring from the electric meter, main control box or service outlet to the electric appliance.

Qualified installation personnel must be experienced in such work, familiar with all precautions required, and have complied with all requirements of state or local authorities having jurisdiction.

### U.S. and Canadian installations

All ovens, when installed, must be electrically grounded in accordance with local codes, or in the absence of local codes, with the *National Electrical Code, ANSI/NFPA 70–Latest Edition* and/or *Canadian National Electric Code C22.2* as applicable.

The ventilation of this oven should be in accordance with local codes. In the absence of local codes, refer to the National ventilation code titled, “*Standard for the Installation of Equipment for the Removal of Smoke and Grease Laden Vapors from Commercial Cooking Equipment*”, NFPA-96-Latest Edition.

### General export installations

Installation must conform with Local and National installation standards. Local installation codes and/or requirements may vary. If you have any questions regarding the proper installation and/or operation of your Blodgett oven, please contact your local distributor. If you do not have a local distributor, please call the Blodgett Oven Company at 0011-802-860-3700.





# Installation

## Electrical Connection

Wiring diagrams are located in the control compartment and on the back of the oven.

The electric motor, indicator lights and related switches are connected to the oven as follows:

1. Remove the bottom trim and control panel covers. Slide the control panel forward.
2. Connect the supply conduit to the wire duct located in the lower left hand corner on the back of the oven.
3. Run the supply wires through the duct to the front of the oven.

4. Connect the supply wires to top of right contactor in the control compartment at the lower right corner of the oven.

5. Reinstall the bottom trim and control panel covers.

*NOTE: To prevent damage there is no power to the heating elements when the blower is not operating.*

THE BLODGETT OVEN COMPANY CANNOT ASSUME RESPONSIBILITY FOR LOSS OR DAMAGE SUFFERED AS A RESULT OF IMPROPER INSTALLATION.

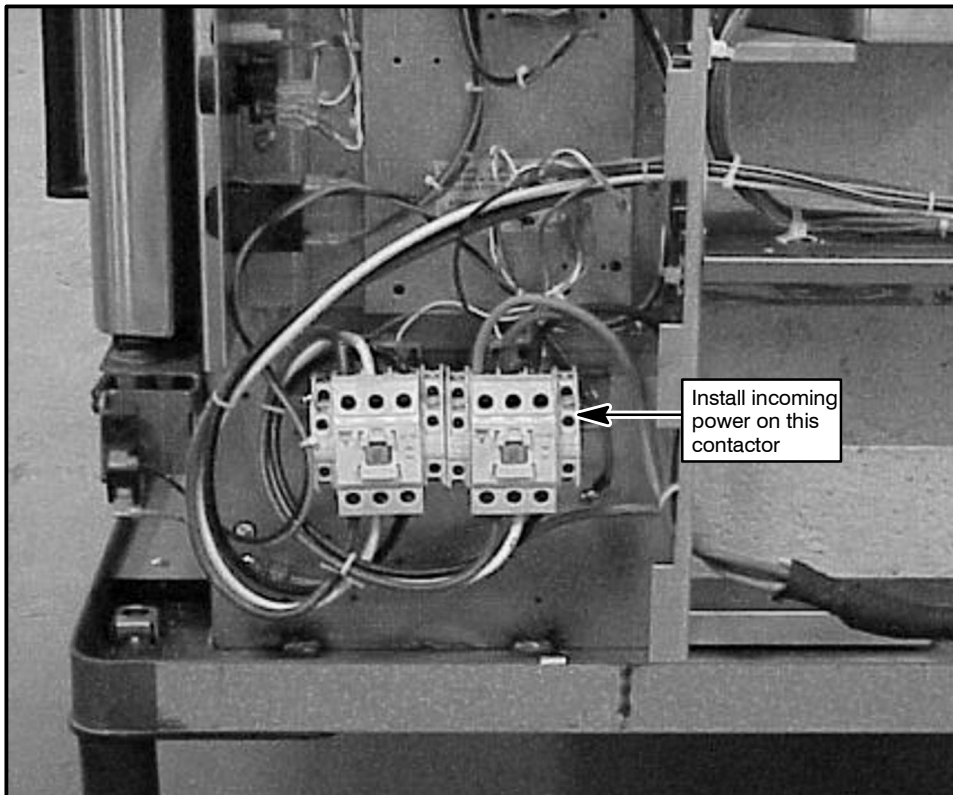

Figure 7



### OVEN RESTRAINT

If casters are used in conjunction with a power supply cord for movable appliances, a fixed restraint should be provided.

The restraint (ie: heavy gauge cable) should be attached without damaging the building. **DO NOT** use the gas piping or electrical conduit for the attachment of the permanent end of the restraint! Use anchor bolts in concrete or cement block. On wooden walls, drive hi test wood lag screws into the studs of the wall.

If the oven is moved from its regular location, the restraint must be reconnected when the oven is returned.

1. Mount the supplied bracket to the leg bolt just below the power cord.
2. Attach the clip on restraining cable to the mounting bracket.

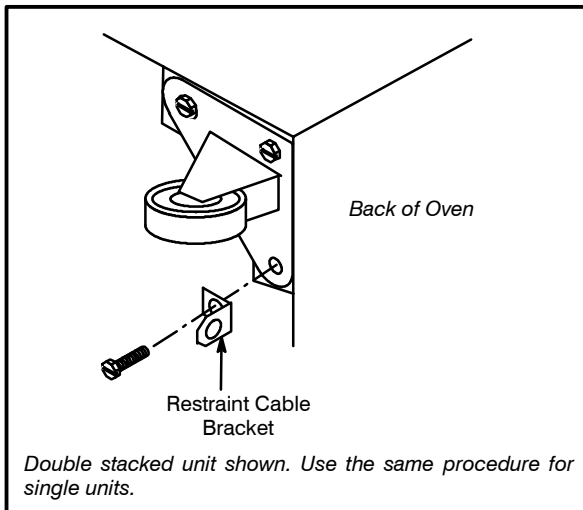

**Figure 8**

### ADJUSTMENTS ASSOCIATED WITH INITIAL INSTALLATION

Each oven, and its component parts, have been thoroughly tested and inspected prior to shipment. However, it is often necessary to further test or adjust the oven as part of a normal and proper installation. These adjustments are the responsibility of the installer, or dealer. Since these adjustments are not considered defects in material or workmanship, they are not covered by the Original Equipment Warranty. They include, but are not limited to:

- calibration of the thermostat
- adjustment of the doors
- leveling
- tightening of fasteners.

No installation should be considered complete without proper inspection, and if necessary, adjustment by qualified installation or service personnel.



## Operation

### Safety Information

THE INFORMATION CONTAINED IN THIS SECTION IS PROVIDED FOR THE USE OF QUALIFIED OPERATING PERSONNEL. QUALIFIED OPERATING PERSONNEL ARE THOSE WHO HAVE CAREFULLY READ THE INFORMATION CONTAINED IN THIS MANUAL, ARE FAMILIAR WITH THE FUNCTIONS OF THE OVEN AND/OR HAVE HAD PREVIOUS EXPERIENCE WITH THE OPERATION OF THE EQUIPMENT DESCRIBED. ADHERENCE TO THE PROCEDURES RECOMMENDED HEREIN WILL ASSURE THE ACHIEVEMENT OF OPTIMUM PERFORMANCE AND LONG, TROUBLE-FREE SERVICE.

Please take the time to read the following safety and operating instructions. They are the key to the successful operation of your Blodgett conveyor oven.



#### **SAFETY TIPS**

**For your safety read before operating**

#### **General safety tips:**

- If the oven needs to be moved for any reason, the supply cord must be disconnected from the unit before removing the restraint cable. Reconnect the restraint after the oven has been returned to its original location.
- DO NOT remove the control panel cover unless the oven is unplugged.

## Solid State Manual Control

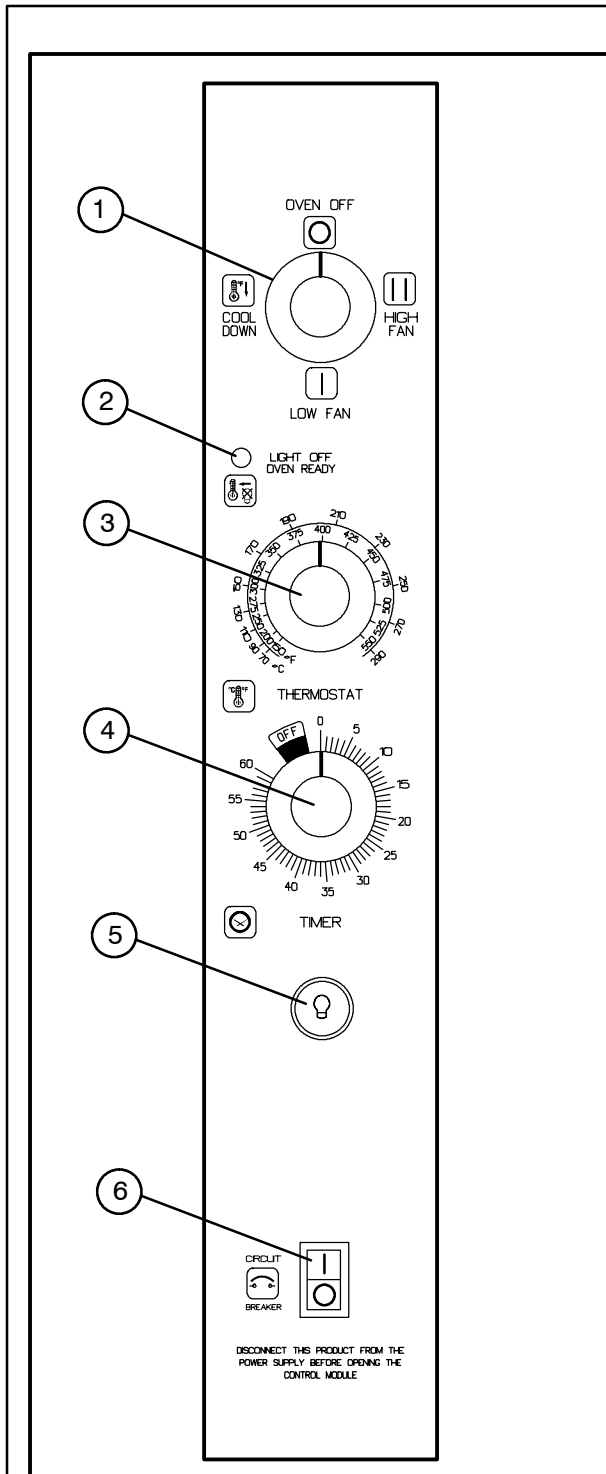

Figure 9

### CONTROL DESCRIPTION

1. SELECTOR SWITCH – controls power to the oven for high fan, low fan or cool down.
2. OVEN READY LIGHT – when lit indicates burner operation. When the light goes out the oven has reached operating temperature.
3. SOLID STATE THERMOSTAT - allows an infinite selection of temperatures from 150-550°F (66-288°C). (infinite control shown)
4. TIMER – activates an electric buzzer that sounds when the cook time expires.
5. LIGHTS SWITCH – controls interior lights.
6. CIRCUIT BREAKER SWITCH – controls power to the oven.

### OPERATION

1. Turn the SELECTOR Switch (1) to either *HIGH FAN* or *LOW FAN*. The blower and control compartment cooling fan operate and are controlled automatically by the action of the doors.
2. Set the SOLID STATE THERMOSTAT (3) to the desired setting or temperature.
3. Preheat until the OVEN READY LIGHT (2) goes out.
4. Load product into the oven. Determine cook time and set the TIMER (4).
5. When the buzzer sounds, remove the product from the oven. Turn the TIMER knob (4) to *OFF* to silence the buzzer.
6. Turn the SELECTOR Switch (1) to *OVEN OFF*.

#### Oven Cool Down:

1. Turn the SELECTOR Switch (1) to *COOL DOWN*.

*NOTE: The doors may be opened to speed the cooling process.*

#### Oven Shut Down:

1. Turn the SELECTOR SWITCH (1) to *OVEN OFF*.



# Operation

## Solid State Digital Control

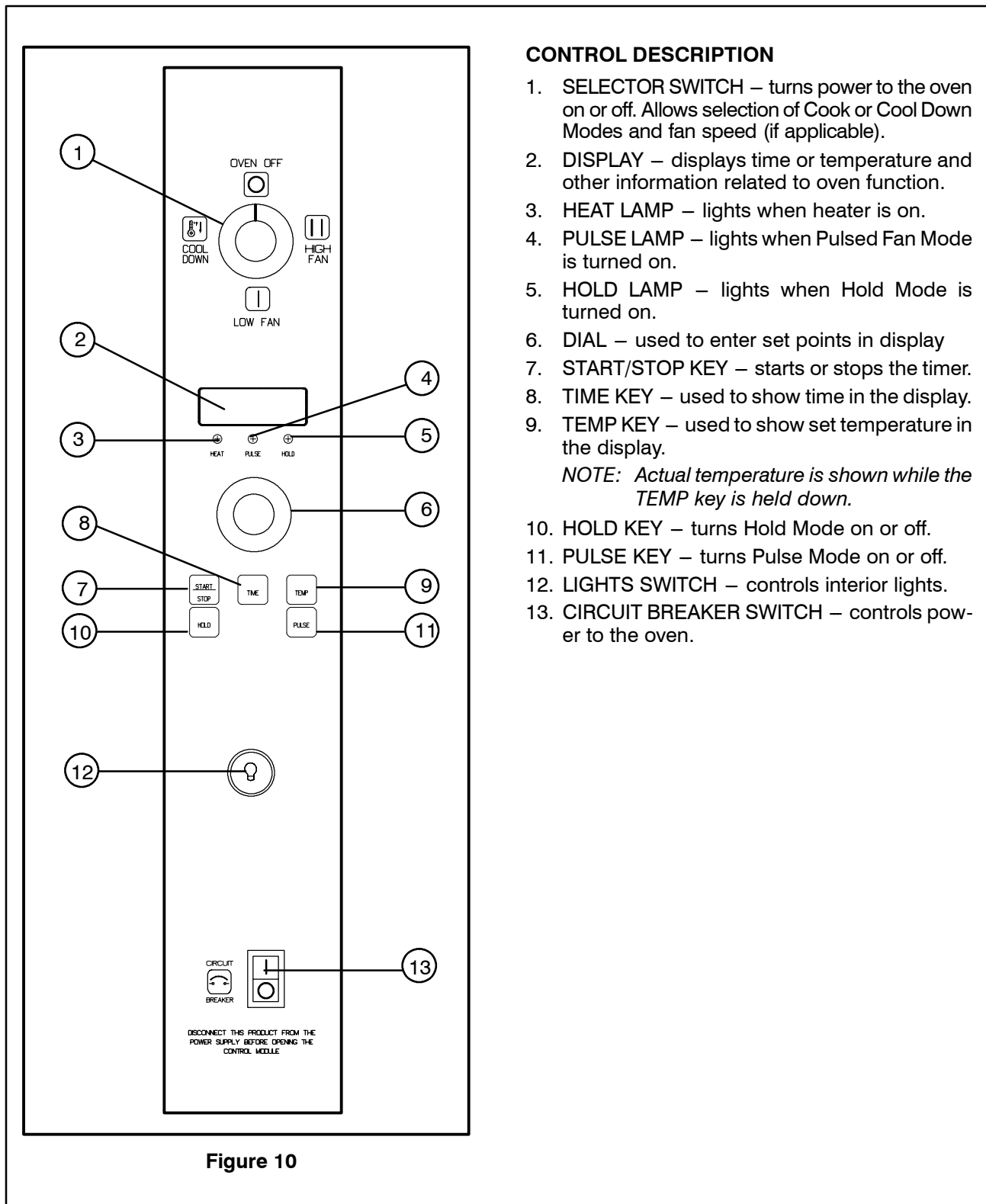

### CONTROL DESCRIPTION

1. SELECTOR SWITCH – turns power to the oven on or off. Allows selection of Cook or Cool Down Modes and fan speed (if applicable).
2. DISPLAY – displays time or temperature and other information related to oven function.
3. HEAT LAMP – lights when heater is on.
4. PULSE LAMP – lights when Pulsed Fan Mode is turned on.
5. HOLD LAMP – lights when Hold Mode is turned on.
6. DIAL – used to enter set points in display
7. START/STOP KEY – starts or stops the timer.
8. TIME KEY – used to show time in the display.
9. TEMP KEY – used to show set temperature in the display.  
*NOTE: Actual temperature is shown while the TEMP key is held down.*
10. HOLD KEY – turns Hold Mode on or off.
11. PULSE KEY – turns Pulse Mode on or off.
12. LIGHTS SWITCH – controls interior lights.
13. CIRCUIT BREAKER SWITCH – controls power to the oven.





### PROGRAMMING

#### To set the cook temperature:

1. Press TEMP (9) key.
2. Rotate dial (6) to enter temperature.

#### To set the cook time:

1. Press TIME (8) key.
2. Rotate the dial (6) to enter time.

*NOTE: Time is entered in hours:minutes (0:00) or minutes:seconds (00:00).*

#### To set the hold time:

1. Press HOLD key (10) to turn hold mode on.  
*NOTE: HOLD light is on.*
2. Rotate dial (6) to enter the hold temperature.
3. Press START/STOP key (7)

#### To set the pulse time:

1. Press PULSE KEY (11) to turn pulse mode on.  
*NOTE: Pulse light is on.*
2. Rotate DIAL (6) to enter the pulse time. Pulse time is a portion of the pre-set cook time.

### OPERATION

#### Cook Only:

1. Turn SELECTOR switch (1) to the desired position.
2. Enter the cook time and temperature.
3. Load product into oven.  
*NOTE: The display reads LOAD with the oven is near the set temperature.*
4. Press the START/STOP key (7). The timer begins to count down.
5. When the cook timer reaches 00:00 the buzzer sounds and the display reads *DONE*.
6. Press the START/STOP key (7) to silence the buzzer.
7. Remove the product.

#### Cook with Hold:

*NOTE: HOLD light is on when hold mode is on and off when hold mode is off.*

1. Turn SELECTOR switch (1) to the desired position.
2. Enter the cook time and temperature.
3. Press the HOLD key (10). Enter the hold temperature.
4. Load product into oven.  
*NOTE: The display reads LOAD with the oven is near the set temperature.*
5. Push the START/STOP (7) key. Timer begins to count down.
6. When the cook timer reaches 00:00 the buzzer sounds and the display reads *DONE*. The buzzer turns off after a few seconds. The display reads *HOLD* until the oven reaches the hold temperature. Then the timer begins to count up.
7. Push the START/STOP key (7) to stop timer.
8. Remove the product.
9. Push HOLD (10) key to turn off hold mode.



# Operation

## Solid State Digital Control

### Cook with Pulse:

*NOTE: PULSE light is on when pulse mode is on and off when pulse mode is off.*

1. Turn the SELECTOR SWITCH (1) to the desired position.
2. Enter cook time and cook temperature.
3. Press PULSE KEY (11). Enter the pulse time. A minimum of one minute must be entered to operate.

*NOTE: Pulse time is a portion of the cook time and does not increase the previously entered cook time.*

4. Load product into oven.  
*NOTE: The display reads LOAD with the oven is near the set temperature.*
5. Push START/STOP KEY (7). The timer begins to count down the cook time. The oven will be in pulse mode for the set pulse time. Once the set time has expired, the unit will automatically switch to cook mode and continue counting down.
6. When the cook timer reaches 00:00 the buzzer sounds and the display reads *DONE*.
7. Push the START/STOP KEY (7) to turn the buzzer off.
8. Remove the product.

### Oven Cool Down:

1. Turn the SELECTOR Switch (1) to *COOL DOWN*.

*NOTE: The doors may be opened to speed the cooling process.*

### Oven Shut Down:

1. Turn the SELECTOR SWITCH (1) to *OVEN OFF*.

## Solid State Digital Control with Humidaire

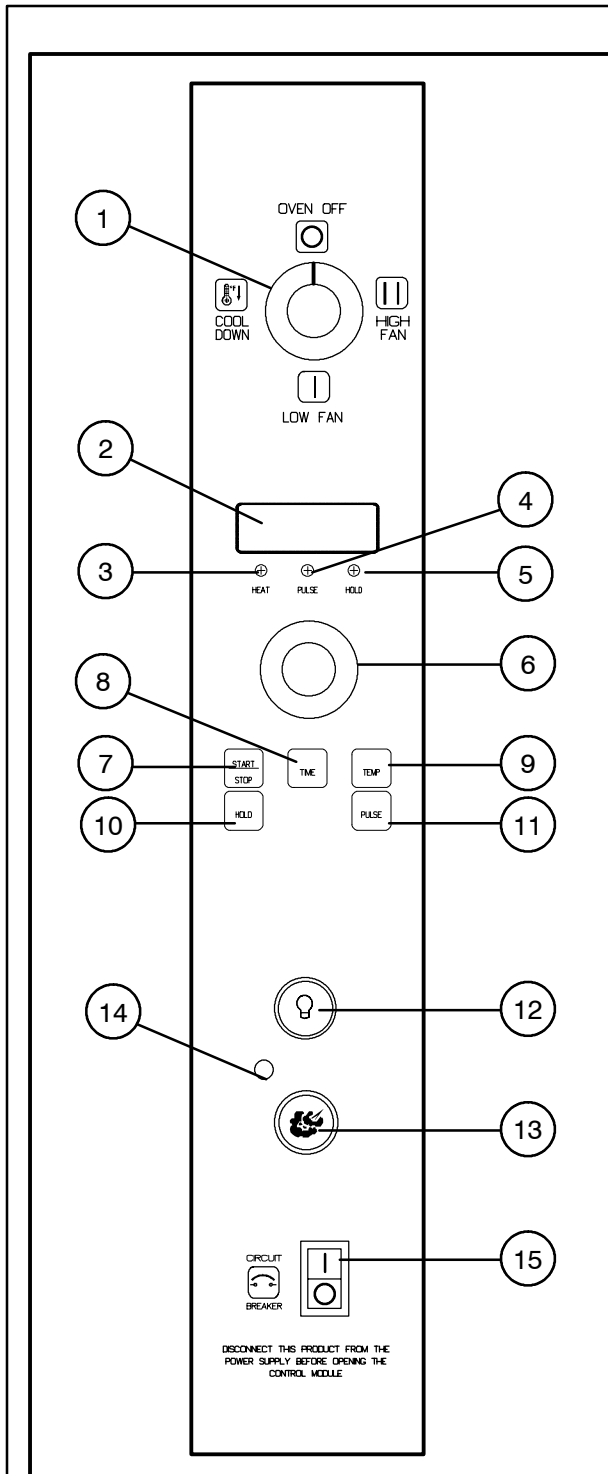

Figure 11

### CONTROL DESCRIPTION

1. SELECTOR SWITCH – controls power to the oven for high fan, low fan or cool down.
2. DISPLAY – displays time or temperature and other information related to oven function.
3. HEAT LAMP – lights when heater is on.
4. PULSE LAMP – lights when Pulsed Fan Mode is turned on.
5. HOLD LAMP – lights when Hold Mode is turned on.
6. DIAL – used to enter set points in display
7. START/STOP KEY – starts or stops the timer.
8. TIME KEY – used to show time in the display.
9. TEMP KEY – used to show set temperature in the display.  
*NOTE: Actual temperature is shown while the TEMP key is held down.*
10. HOLD KEY – turns Hold Mode on or off.
11. PULSE KEY – turns Pulse Mode on or off.
12. LIGHTS SWITCH – controls interior lights.
13. HUMIDAIRE START SWITCH – activates moisture injection for a preset period of 30 seconds.
14. HUMIDAIRE LAMP – lights when water is being injected
15. CIRCUIT BREAKER SWITCH – controls power to the oven.



# Operation

## Solid State Digital Control with Humidaire

### PROGRAMMING

#### To set the cook temperature:

1. Press TEMP (9) key.
2. Rotate dial (6) to enter temperature.

#### To set the cook time:

1. Press TIME (8) key.
2. Rotate the dial (6) to enter time.

*NOTE: Time is entered in hours:minutes (0:00) or minutes:seconds (00:00).*

#### To set the hold time:

1. Press HOLD key (10) to turn hold mode on.  
*NOTE: HOLD light is on.*
2. Rotate dial (6) to enter the hold temperature.
3. Press START/STOP key (7)

#### To set the pulse time:

1. Press PULSE KEY (11) to turn pulse mode on.  
*NOTE: Pulse light is on.*
2. Rotate DIAL (6) to enter the pulse time. Pulse time is a portion of the pre-set cook time.

### OPERATION

#### Cook Only:

1. Turn the SELECTOR switch (1) to the desired position.
2. Enter the cook time and temperature.
3. Load product into the oven.  
*NOTE: The display reads LOAD when the oven is near the set temperature.*
4. Press the START/STOP key (7). The timer begins to count down.
5. When the cook timer reaches 00:00 the buzzer sounds and the display reads *DONE*.
6. Press the START/STOP key (7) to silence the buzzer.
7. Remove the product.

#### Cook with Hold:

*NOTE: HOLD light is on when hold mode is on and off when hold mode is off.*

1. Turn the SELECTOR switch (1) to the desired position.
2. Enter the cook time and temperature.
3. Press the HOLD key (10). Enter the hold temperature.
4. Load product into the oven.  
*NOTE: The display reads LOAD when the oven is near the set temperature.*
5. Push the START/STOP (7) key. Timer begins to count down.
6. When the cook timer reaches 00:00 the buzzer sounds and the display reads *DONE*. The buzzer turns off after a few seconds. The display reads *HOLD* until the oven reaches the hold temperature. Then the timer begins to count up.
7. Push the START/STOP key (7) to stop timer.
8. Remove the product.
9. Push HOLD (10) key to turn off hold mode.

#### Cook with Pulse:

*NOTE: PULSE light is on when pulse mode is on and off when pulse mode is off.*

1. Turn the SELECTOR SWITCH (1) to the desired position.
2. Enter cook time and cook temperature.
3. Press PULSE KEY (11). Enter the pulse time. A minimum of one minute must be entered to operate.  
*NOTE: Pulse time is a portion of the cook time and does not increase the previously entered cook time.*
4. Load product into the oven.  
*NOTE: The display reads LOAD when the oven is near the set temperature.*



## Solid State Digital Control with Humidaire

5. Push START/STOP KEY (7). The timer begins to count down the cook time. The oven will be in pulse mode for the set pulse time. Once the set time has expired, the unit will automatically switch to cook mode and continue counting down.
6. When the cook timer reaches 00:00 the buzzer sounds and the display reads *DONE*.
7. Push the START/STOP KEY (7) to turn the buzzer off.
8. Remove the product.

### Oven Cool Down:

1. Turn the SELECTOR Switch (1) to *COOL DOWN*.  
*NOTE: The doors may be opened to speed the cooling process.*

### Oven Shut Down:

1. Turn the SELECTOR SWITCH (1) to *OVEN OFF*.

### The Humidaire Function:

Moisture may be injected into the oven cavity at any time during the cook cycle.

1. Press the HUMIDAIRE START SWITCH (13). Water injects into the oven cavity for 30 seconds. After the water stops injecting, the motor automatically turns off for 30 seconds. This enables the moisture to saturate the product. Once the humidaire cycle is complete, the oven resumes normal operation.

*NOTE: The oven must be above 230 °F (110 °C) for humidaire to operate.*

The amount of water injected during the Humidaire cycle may be adjusted as follows:

1. Check the pressure gauge on the back of the oven while the water is dispensing. The pressure should be no higher than 3 psi. If less moisture is desired, the pressure can be set below 3 psi.
2. To adjust the water pressure, loosen the locknut on the pressure regulator.  
Turn the adjusting screw counter clockwise to decrease the water pressure.  
Turn the adjusting screw clockwise to increase the water pressure if it is below 3 psi.  
*NOTE: Increasing the water pressure will increase the amount of water injected during the humidaire cycle. Decreasing the pressure will decrease the water injected during the humidaire cycle.*
3. Reset the locknut on the regulator.
4. Recheck the water pressure.

### **WARNING!!**

**Setting the pressure above 3 psi will lead to excessive water in the oven.**

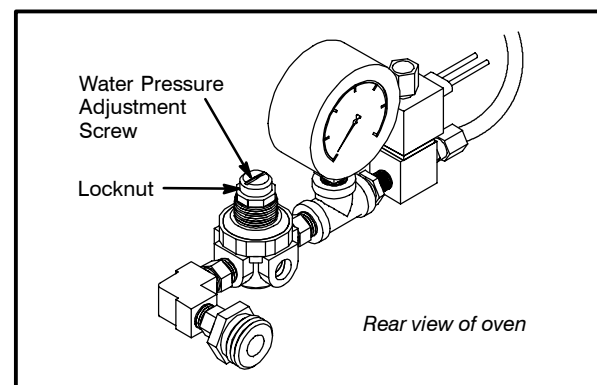

**Figure 12**



# Operation

## CH-Pro3 (Solid State Programmable Digital Control)

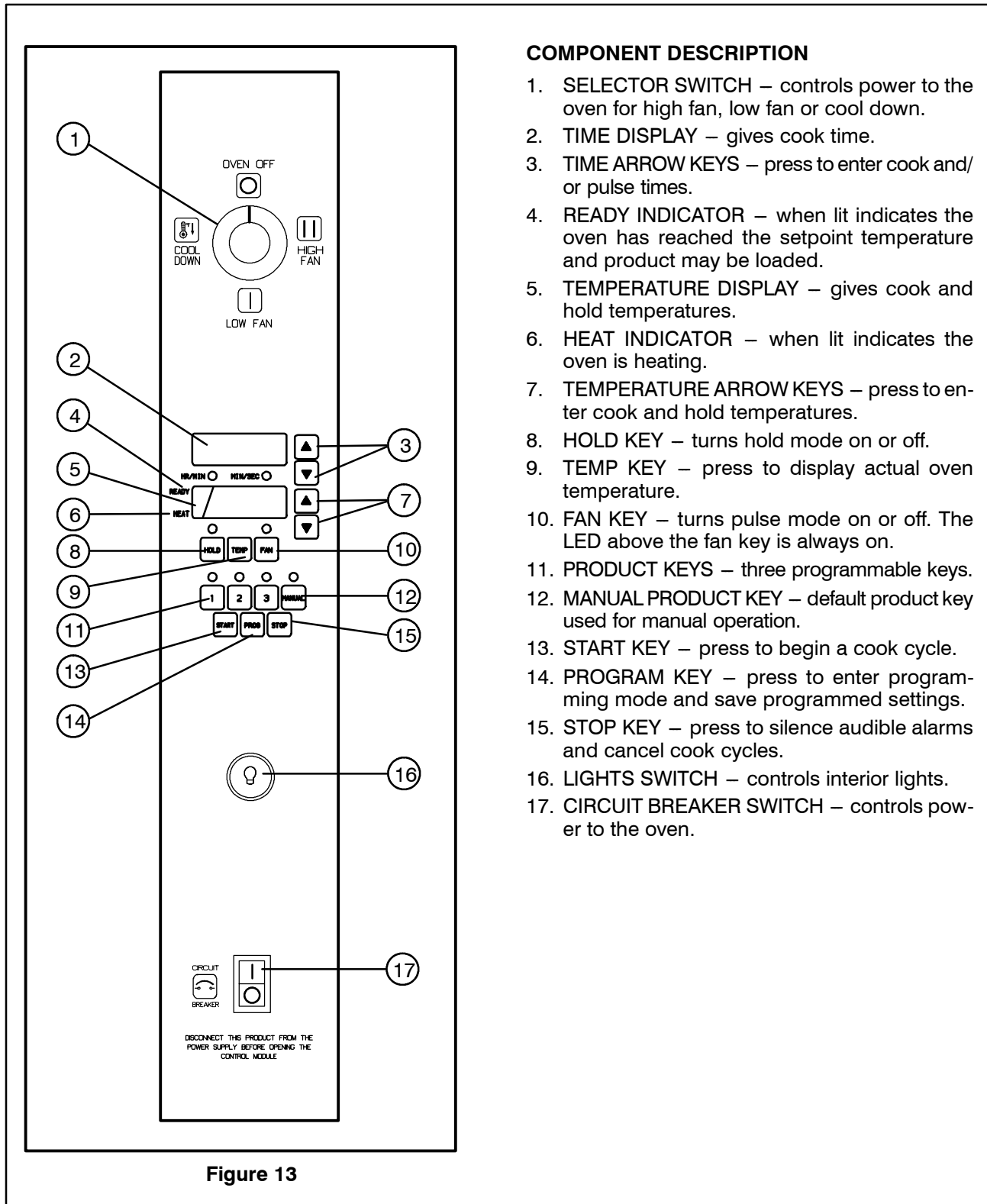

Figure 13

## CH-Pro3 (Solid State Programmable Digital Control)

### MANUAL OPERATION

*NOTE: Press the arrow keys to change the cook time and temperature at any point during manual operation.*

#### Cook Only:

1. Turn the SELECTOR SWITCH (1) to the desired position.
2. Press the TIME ARROW KEYS (3) to enter the cook time.
3. Press the TEMPERATURE ARROW KEYS (7) to enter the cook temperature.
4. The READY INDICATOR (4) lights when the oven is at the set temperature. Load product into the oven.
5. Press the START KEY (13). The TIME DISPLAY (2) counts down. The manual key LED flashes.
6. When the cook time expires the LEDs and both displays flash and an audible alarm sounds. Press the STOP KEY (15) to silence the alarm.
7. Remove the product.

#### Cook with Hold:

1. Turn the SELECTOR SWITCH (1) to the desired position.
2. Press the TIME ARROW KEYS (3) to enter the cook time.
3. Press the TEMPERATURE ARROW KEYS (7) to enter the cook temperature.
4. Press and hold the HOLD KEY (8) then release. Use the TEMPERATURE ARROW KEYS (7) to enter the hold temperature. The hold key LED lights. Press the hold key again to exit the hold mode.
5. The READY INDICATOR (4) lights when the oven is at the set temperature. Load product into the oven.
6. Press the START KEY (13). The TIME DISPLAY (2) counts down. The manual key LED flashes.
7. When the cook time expires both displays flash and an audible alarm sounds for several seconds then self cancels. The hold key LED flashes. The time display begins to count up while the oven cools to the hold temperature.

When the oven reaches the hold temperature the time display resets to 00:00 then begins to count up the hold time. The fan cycles with heat demand in the hold mode.

8. Press the STOP KEY (15) to stop the timer.
9. Remove the product.
10. Push the HOLD KEY (8) to turn off hold mode.

#### Cook with Pulse:

1. Turn the SELECTOR SWITCH (1) to the desired position.
2. Press the TIME ARROW KEYS (3) to enter the cook time.
3. Press the TEMPERATURE ARROW KEYS (7) to enter the cook temperature.
4. Press the FAN KEY (10) for five seconds. The TEMPERATURE DISPLAY (5) goes blank. The fan key LED flashes. Use the TIME ARROW KEYS (3) to enter the pulse time.

*NOTE: Pulse time is a portion of the cook time and does not increase the previously entered cook time.*

5. Press the FAN KEY (10) again. The TEMPERATURE DISPLAY (5) lights.
6. The READY INDICATOR (4) in the temperature display lights when the oven is at the set temperature. Load product into the oven.
7. Press the START KEY (13). The manual key LED flashes. The TIME DISPLAY (2) counts down the cook time. The fan cycles on for 30 seconds then off for 30 seconds until the set pulse time has expired.
8. When the pulse time expires both displays flash and an audible alarm sounds. Press the STOP KEY (15) to silence the alarm.
9. Remove the product.

#### Oven Cool Down:

1. Turn the SELECTOR Switch (1) to *COOL DOWN*.

*NOTE: The doors may be opened to speed the cooling process.*

#### Oven Shut Down:

1. Turn the SELECTOR SWITCH (1) to *OVEN OFF*.



# Operation

## CH-Pro3 (Solid State Programmable Digital Control)

### PROGRAMMING THE MANUAL KEY DEFAULT

1. Turn the SELECTOR SWITCH (1) to the desired position.
2. Press the MANUAL KEY (12). The manual and fan key LEDs light.
3. Press the TIME ARROW KEYS (3) to enter the cook time.
4. Press the TEMPERATURE ARROW KEYS (7) to enter the cook temperature.
5. **For Cook and Hold** – Press and hold the HOLD KEY (8). Use the TEMPERATURE ARROW KEYS (7) to enter the hold temperature. The hold key LED lights. Press the hold key again to exit the hold mode.  
**For Cook with Pulse** – Press the FAN KEY (10). Use the TIME ARROW KEYS (3) to enter the pulse time. If no pulse is required, leave pulse time at 0:00. The fan key LED flashes. Press the fan key again to exit fan mode.
6. Press the PROGRAM KEY (14) to save the program settings.

### MANUAL KEY DEFAULT OPERATION

1. Turn the SELECTOR SWITCH (1) to the desired position.
2. Press the MANUAL KEY (12). The applicable LEDs light.
3. Press the START KEY (13). The TIME DISPLAY (2) counts down. The manual key LED flashes.  
*NOTE: In Cook with Pulse the fan LED flashes.*  
*NOTE: Press the arrow keys to change the cook time and temperature at any point during manual key operation.*
4. When the cook time expires the applicable LEDs and both displays flash and an audible alarm sounds.
5. Press the STOP KEY (15) to silence the alarm.  
*NOTE: In Cook & Hold the alarm self cancels. The oven cools to the hold temperature and the time display counts up.*
6. Remove the product.
7. Turn the SELECTOR SWITCH (1) to OFF to shut down the oven.

### PROGRAMMING THE PRODUCT KEYS

1. Turn the SELECTOR SWITCH (1) to the desired position.
2. Press the desired PRODUCT KEY (11). The product and fan key LEDs light.
3. Press and hold the PROGRAM KEY (14) until the corresponding LED flashes, approximately five seconds.
4. Press the TIME ARROW KEYS (3) to enter the cook time.
5. Press the TEMPERATURE ARROW KEYS (7) to enter the cook temperature.
6. **For Cook and Hold** – Press and hold the HOLD KEY (8). Use the TEMPERATURE ARROW KEYS (7) to enter the hold temperature. The hold key LED lights. Press the hold key again to exit the hold mode.  
**For Cook with Pulse** – Press the FAN KEY (10). Use the TIME ARROW KEYS (3) to enter the pulse time. If no pulse is required, leave pulse time at 0:00. The fan key LED flashes. Press the fan key again to exit the fan mode.
7. Press the PROGRAM KEY (14) to save the program settings.

### PRODUCT KEY OPERATION

1. Turn the SELECTOR SWITCH (1) to the desired position.
2. Press the desired PRODUCT KEY (11). The applicable LEDs light.
3. Press the START KEY (13). The TIME DISPLAY (2) counts down. The product key LED flashes.  
*NOTE: In Cook with Pulse the fan LED flashes.*
4. When the cook or pulse time expires the applicable LEDs and both displays flash and an audible alarm sounds.
5. Press the STOP KEY (15) to silence the alarm.  
*NOTE: In Cook & Hold the alarm self cancels. The oven cools to the hold temperature and the time display counts up.*
6. Remove the product.
7. Turn the SELECTOR SWITCH (1) to OFF to shut down the oven.



## Blodgett IQ2™ Control

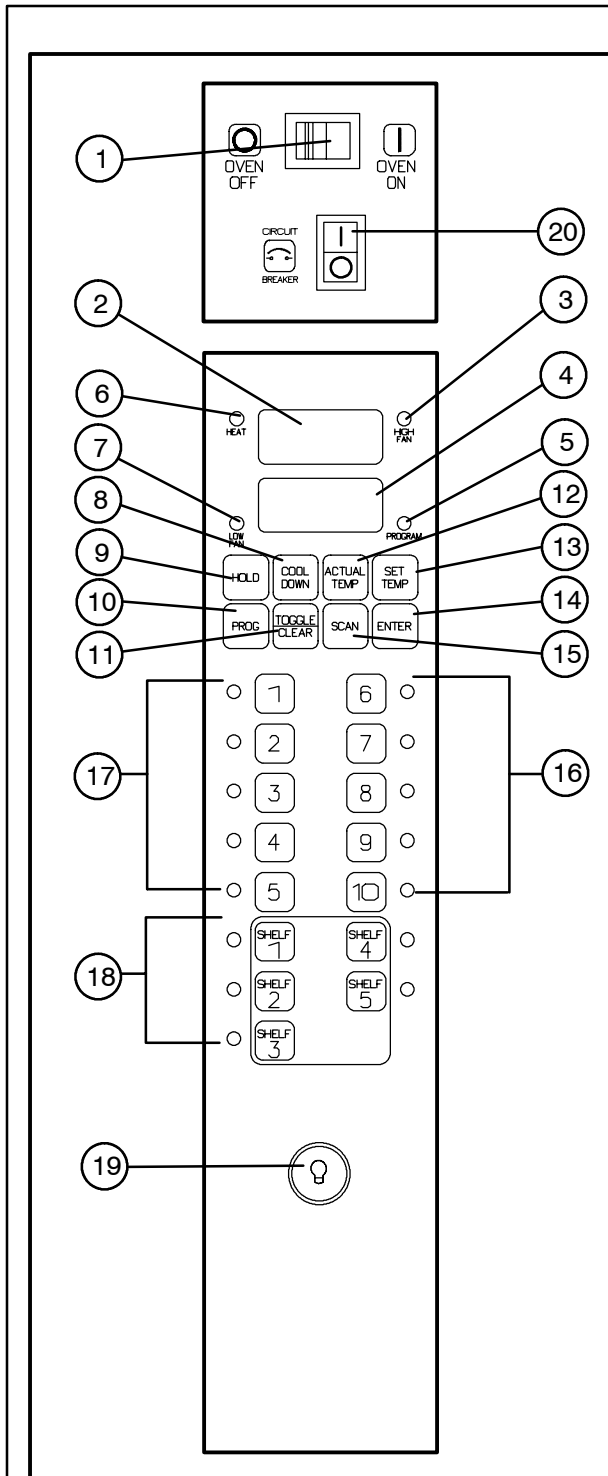

Figure 14

### COMPONENT DESCRIPTION

1. OVEN POWER SWITCH – controls power to the oven.
2. TOP DISPLAY – displays temperature and other controller related information.
3. FAN HI LED – when lit indicates the fan is running at high speed.
4. BOTTOM DISPLAY – displays cook time and other controller related information.
5. PROG LED – when lit indicates the controller is in the programming mode.
6. HEAT LED – when lit indicates the control is calling for heat.
7. FAN LO LED – when lit indicates the fan is running at low speed.
8. COOL DOWN KEY – press to enter the cool down mode.
9. HOLD KEY – press to enter hold mode.
10. PROG KEY – press to enter the programming mode.
11. TOGGLE/CLEAR KEY – press during programming to toggle options.
12. ACT TEMP KEY – press to display the actual oven temperature.
13. SET TEMP KEY – press to display the programmed cook temperature for the current stage of the product key.
14. ENTER KEY – press to enter new values into product key programming. Also used to view recovery time.
15. SCAN KEY – completes the programming for the current parameter and advances the controller to the next parameter. Press to view time remaining on multiple cook cycles.
16. PRODUCT LEDS – when lit indicate which product keys are currently in use or programmed for the current oven temperature and fan speed.
17. PRODUCT KEYS – assigns a key to a programmed recipe and begins a programmed cooking process.
18. SHELF KEYS – assigns a shelf key.
19. LIGHTS SWITCH – controls interior lights.
20. CIRCUIT BREAKER SWITCH – controls power to the oven.



# Operation

## Blodgett IQ2™ Control

### OVEN OPERATION

#### Oven Startup:

1. Toggle the POWER SWITCH (1) to ON. The oven preheats to the lowest programmed first stage temperature. The LEDS (16) for all products with the same first stage temperature light. While the unit preheats the TOP DISPLAY (2) gives the set temperature. The BOTTOM DISPLAY (4) reads *Lo* if the oven is more than 10° below setpoint. When the oven reaches  $\pm 10^\circ$  of the preheat temperature an alarm sounds and the bottom display reads *Ready*.

#### Single Product Cooking Procedure:

*NOTE: If the led next to the desired product key is lit skip step 1.*

1. Press the desired PRODUCT KEY (17). The oven preheats to the first stage temperature for the selected product. When the oven reaches  $\pm 10^\circ$  of the preheat temperature an alarm sounds and the bottom display reads *Ready*.
2. Load the product into the oven. Press the desired PRODUCT KEY (17).

If the shelf timing function is toggled on for that product key, the top display reads *SHLF* and the bottom display reads the programmed product's time. Press a SHELF KEY (18) to assign the product to that shelf and start the cook cycle. The top display reads *SHLF*, the bottom display gives the shelf #. Within five seconds, the top display reads *SH-1*, the bottom display gives the remaining cook time.

If the shelf timing function is toggled off for that product key, pressing the product key will start the cook cycle. The TOP DISPLAY (2) reads ----. The BOTTOM DISPLAY (4) counts down the cook time in minutes: seconds.

*NOTE: If the selected product has a cook time of greater than 59:59 the top display reads Hr-- for the total number of hours. The bottom display counts down the cook time in minutes:seconds.*

*NOTE: If the selected product is a single stage recipe the LEDS for all single stage products with the same cook tempera-*

*ture and fan speed will light. If the selected product is a multiple stage recipe no other product LEDS will light.*

*NOTE: Press and hold the selected product key for three seconds to cancel the cook cycle for normal operation. To cancel the cook cycle when using shelf timing, press and hold the SHELF KEY (18) for 3 seconds or press TOGGLE/CLEAR (11) and the corresponding shelf key.*

3. When the cook time expires an alarm sounds and the top display reads *done*.
4. Press the selected product key to silence the alarm. Remove the product. If shelf timing is used, press the flashing SHELF KEY (18) to silence the alarm.

#### Multiple Batch Cooking Procedure:

This procedure is for single stage recipes with the same cook temperature and fan speed only.

*NOTE: If the led next to the first desired product key is lit skip step 1.*

1. Press the first desired PRODUCT KEY (17). The LEDS for all recipes with the same cook temperature and fan speed will light. The oven preheats to the cook temperature for the selected product. When the oven reaches  $\pm 10^\circ$  of the preheat temperature an alarm sounds and the bottom display reads *Ready*.
2. Load the product into the oven. Press the desired PRODUCT KEY (17).

If the shelf timing function is toggled on for that product key, the top display reads *SHLF* and the bottom display reads the programmed product's time. Press a SHELF KEY (18) to assign the product to that shelf and start the cook cycle. The top display reads *SHLF*, the bottom display gives the shelf #. Within five seconds, the top display reads *SH-1*, the bottom display gives the remaining cook time.

If the shelf timing function is toggled off for that product key, pressing the product key will start the cook cycle. The TOP DISPLAY (2) reads ----. The BOTTOM DISPLAY (2) counts down the cook time in minutes: seconds.



3. Load the second product. Press the appropriate PRODUCT KEY (17). Press a SHELF KEY (18) to activate shelf timing.

*NOTE: Only products with lighted LEDS may be selected.*

4. The top display reads *SHLF*. The bottom display gives the numbers of the shelves that have been assigned. Within five seconds the shelf with the least amount of time remaining is displayed. The led for the product with the least time remaining flashes faster than the led for the other products.

*NOTE: To view the remaining cook time for the other products press and hold the SCAN KEY (15). The bottom display cycles through the remaining cook times for each product. Only the led for the product with the cook time displayed will be lit.*

5. When a cook time expires an alarm sounds. The top display reads *donE*. The led for the finished product lights. All other LEDS are dark.
6. Press the SHELF KEY (18) for the finished product to silence the alarm. Remove the product. Close the oven door. The TOP DISPLAY (2) reads *SH-X* for the shelf with the least amount of cook time. The BOTTOM DISPLAY (4) counts down the cook time for the other product.
7. When the cook time expires an alarm sounds and the top display reads *donE*.
8. Press the SHELF KEY (18) to silence the alarm. Remove the product.

### **Oven Cool Down:**

1. Close the oven door. Press the COOL DOWN KEY (8).

*NOTE: Cool down cannot be activated with the oven door open. Once the cool down cycle has begun the doors may be opened to speed the cooling process.*



# Operation

## Blodgett IQ2™ Control

### PROGRAMMING SINGLE STAGE RECIPES

#### Entering the Programming Mode:

1. Press and hold the PROG KEY (10). The top display reads *CodE*.
2. Use the product keys to enter the programming access code: 3 1 2 4. Press the ENTER KEY (14). The top display reads *Prod*.
3. Press the desired product key followed by the ENTER KEY (14).

*NOTE: During the programming process you may: Press the TOGGLE/CLEAR KEY (11) to erase the current setting or toggle between specific settings. Press the SCAN KEY (15) to move to the next programming function keeping the current setting the same. Press the PROG KEY (10) to exit the programming mode.*

#### Programming the Cook Time:

1. The top display reads P1:\_\_. The bottom display gives the current programmed cook time for stage 1 in minutes:seconds. Press the TOGGLE/CLEAR KEY (11). Use the product keys to enter the new cook time. Press the ENTER KEY (14) to save the new cook time.
2. The top display reads P2:\_\_. The control is asking for the cook time for stage 2 of this recipe. Press the TOGGLE/CLEAR KEY (11) to enter a time of 0:00:00 for P2:.

*NOTE: This tells the controller that there are no more stages for this recipe. Once a single stage recipe has been established the control will only allow entries for one stage on all further parameters for this product.*

3. Press the ENTER KEY (14) again. The top display reads P1:. The bottom display shows the cook time.
4. Press the SCAN KEY (15) to advance the programming mode to cook temperature.

#### Programming the Cook Temperature:

1. The top display reads *Ct-1*. The bottom display gives the current cook temperature. Use the product keys to enter the desired cook temperature.
2. Press the SCAN KEY (15) to advance the programming mode to fan speed.

#### Programming the Fan Speed:

1. The top display reads *SPd1*. The bottom display gives the current fan speed. Press the TOGGLE/CLEAR KEY (11). The bottom display toggles between *Hl* and *Lo*.
2. Press the SCAN KEY (15) to advance the programming mode to the fan cycle time.

#### Programming the Fan Cycle Time:

There are 3 options for fan cycle time: Pulse, Heat and Full. Pulse allows the fan to turn on and off as programmed. Heat allows the fan to operate with heat only. Full provides continuous fan operation.

1. The top display reads *CYC1*. The bottom display gives the current fan cycle. Press the TOGGLE/CLEAR KEY (11). The bottom display toggles between *PULS*, *HEAt* and *FULL*.
2. If heat or full are selected press the SCAN KEY (15) to save the new fan cycle and advance to timing mode.

If pulse is selected press the SCAN KEY (15) and continue with Steps 3–4 to program the pulse cycle.

3. The top display reads *on-1*. The bottom display gives the current pulse on time. Use the product keys to enter the desired pulse on time from 10 to 60 seconds. Press the SCAN KEY (15).
4. The top display reads *of-1*. The bottom display gives the current pulse off time. Use the product keys to enter the desired pulse off time from 10 to 60 seconds. Press the SCAN KEY (15) to advance the programming mode to shelf mode.

### Programming the Shelf ID:

The Shelf ID option can be turned on or off for specific product keys.

*NOTE: Shelf ID is not allowed with multiple stage recipes.*

1. The top display reads *SHLF*. The bottom display reads the current shelf ID mode. Press the TOGGLE/CLEAR KEY (11) to toggle between yes and no. Press the SCAN KEY (15) to advance the programming mode to timing.

### Programming the Timing Mode:

There are 3 options for timing mode: Straight, Flex and Sensitivity.

1. The top display reads *tC-1*. The bottom display gives the current timing mode. Press the TOGGLE/CLEAR KEY (11) to toggle between *St*, *FL* and *SEns*.

*NOTE: Sensitivity adjusts the cook time to compensate for any difference between the setpoint and actual temperature. The lower the sensitivity value the shorter the time adjustment. Sensitivity values are set in the manager level programming.*

If Shelf ID is activated, all three timing modes are available. If Shelf ID is not activated, only straight or flex timing modes are available.

2. Press the SCAN KEY (15) to advance the programming mode to hold mode.

### Programming Hold Mode:

The hold mode can be toggled on or off for specific product keys.

1. The top display reads *HOLD*. The bottom display reads the current hold mode. Press TOGGLE/CLEAR KEY (11) to toggle between on and off. Press the SCAN KEY (15).
2. If the hold mode is activated, the bottom display give the current hold time. Press the TOGGLE/CLEAR KEY (11). Use the product keys to enter the new hold time. Press the SCAN KEY (15).
3. The bottom display gives the current hold temperature. Press the TOGGLE/CLEAR KEY (11). Use the product keys to enter the new hold temperature from 140-210°F (60-99°C). Press the SCAN KEY (15).
4. The top display reads *HFAN* (hold fan speed). The bottom display gives the current hold fan speed setting. Press the TOGGLE/CLEAR KEY (11) to toggle between high and low. Press the SCAN KEY (15) to exit the hold mode programming.

### Check all Settings (SEE Mode):

The SEE mode allows the operator to scroll through and view settings of a particular product key.

1. Press the PROG KEY (10). The top display reads *Code*.
2. Use the product keys to enter the SEE access code: 2 4 4 4. Press the ENTER KEY (14). The top display reads *SEE*.
3. Press the product key you wish to view. Press the ENTER KEY (14).
4. The control will automatically scroll through the programmable features showing the programmed values for each.

### Exiting the programming mode:

1. The top display reads *Prod*. Press the PROG KEY (10). The control returns to operating mode.



# Operation

## Blodgett IQ2™ Control

### PROGRAMMING MULTIPLE STAGE RECIPES

#### Entering the Programming Mode:

1. Press and hold the PROG KEY (10). The top display reads *CodE*.
2. Use the product keys to enter the programming access code: 3 1 2 4. Press the ENTER KEY (14). The top display reads *Prod*.
3. Press the desired product key followed by the ENTER KEY (14).

#### Programming the Cook Time:

*NOTE: When multiple stage cooking is being used, the countdown time displayed during cooking is the sum of all stages.*

1. The top display reads P1:\_\_. The bottom display gives the current programmed cook time for stage 1 in minutes:seconds. Press the TOGGLE/CLEAR KEY (11). Use the product keys to enter the new cook time. Press the ENTER KEY (14) to save the new cook time.
2. The top display reads P2:\_\_. The control is asking for the cook time for the second stage of this recipe. Repeat Step 1 for each additional stage.
3. When the cook times for all stages are programmed, press the TOGGLE/CLEAR KEY (11) to clear the bottom display.

*NOTE: This tells the controller that there are no more stages for this recipe. Once the number of stages has been established the control will only allow entries for these stages on all further parameters for this product.*

4. Press the ENTER KEY (14) again. The display reads P1:. The bottom display shows the cook time.
5. Press the SCAN KEY (15) to advance the programming mode to cook temperature.

#### Programming the Cook Temperature:

1. The top display reads *Ct-1*. The bottom display gives the current cook temperature for stage 1 of this recipe. Use the product keys to enter the desired cook temperature.
2. Press the ENTER KEY (14) to save the new cook temperature for stage 1. The top display reads *Ct-2*.

*NOTE: Repeat Steps 1-2 to program the cook temperature for additional stages. When the cook temperature for the final stage has been entered the top display reads *Ct-1*.*

3. Press the SCAN KEY (15) to advance the programming mode to fan speed

#### Programming the Fan Speed:

1. The top display reads *SPd1*. The bottom display gives the current fan speed. Press the TOGGLE/CLEAR KEY (11). The bottom display toggles between *Hi* and *Lo*.
2. Press the SCAN KEY (15) to advance the programming mode to the fan cycle time.



### Programming the Fan Cycle Time:

There are 3 options for fan cycle time: Pulse, Heat and Full. Pulse allows the fan to turn on and off as programmed. Heat allows the fan to operate with heat only. Full provides continuous fan operation.

1. The top display reads *CYC1*. The bottom display gives the current fan cycle for stage 1. Press the TOGGLE/CLEAR KEY (11). The bottom display toggles between *PULS*, *HEAt* and *FULL*.

2. Press the ENTER KEY (14) to save the new fan cycle for stage 1. The top display reads *CYC2*.

*NOTE: Repeat Steps 1–2 to program the fan cycle for additional stages.*

3. When the fan cycle for the final stage has been entered press the SCAN KEY (15).

If no pulse cycles are programmed the control advances to timing mode.

If pulse is used, the control returns to the first stage programmed for the pulse fan option. Follow Steps 4–5 to program the pulse on and off time.

4. The top display reads *on–x*. The bottom display gives the current pulse on time for this stage. Use the product keys to enter the desired pulse on time from 10 to 60 seconds. Press the SCAN KEY (15).

5. The top display reads *of–x*. The bottom display gives the current pulse off time. Use the product keys to enter the desired pulse off time from 10 to 60 seconds. Press the SCAN KEY (15). The control advances to the next stage programmed for the pulse fan option.

*NOTE: Repeat Steps 4–5 to program cycle times for all pulse fan stages. When the final pulse off time has been entered the control advances to timing mode.*

### Programming the Timing Mode:

*NOTE: It may be necessary to press the ENTER KEY (14) until the top display reads *tC–1*.*

There are 2 options for timing mode: Straight and Flex.

1. The top display reads *tC–1*. The bottom display gives the current timing mode. Press the TOGGLE/CLEAR KEY (11) to toggle between *St*, and *FL*.

2. Press the ENTER KEY (14) to save the new timing mode for stage 1. The top display reads *tC–2*.

*NOTE: Repeat Steps 1–2 to program the timing mode for additional stages.*

3. When the timing mode for the final stage has been entered press the SCAN KEY (15).

### Programming Hold Mode:

The hold mode can be toggled on or off for specific product keys.

1. The top display reads *HOLD*. The bottom display reads the current hold mode. Press TOGGLE/CLEAR KEY (11) to toggle between on and off. Press the SCAN KEY (15).

2. The bottom display give the current hold time. Press the TOGGLE/CLEAR KEY (11). Use the product keys to enter the new hold time. Press the SCAN KEY (15).

3. The bottom display gives the current hold temperature. Press the TOGGLE/CLEAR KEY (11). Use the product keys to enter the new hold temperature from 140-210°F (60-99°C). Press the SCAN KEY (15).

4. The top display reads *HFAN* (hold fan speed). The bottom display gives the current hold fan speed setting. Press the TOGGLE/CLEAR KEY (11) to toggle between high and low. Press the SCAN KEY (15) to exit the hold mode programming.

### Exiting the programming mode:

1. The top display reads *Prod*. Press the PROG KEY (10). The control returns to operating mode.



# Operation

## Blodgett IQ2™ Control

### MANAGER LEVEL PROGRAMMING

#### Entering the programming mode

1. Press the PROG KEY (10). The top display reads *Code*.
2. Use the product keys to enter the programming access code: 4 5 1 2. Press the ENTER KEY (14). The top display reads *SYS*.

#### Programming hold

Hold allows product to be kept warm in the oven at a programmed time and temperature by pressing the HOLD KEY (9).

1. Press the SCAN KEY (15). The top display reads *Hold*. Press the TOGGLE/CLEAR KEY (11) to toggle between *YES* and *no*. Press the SCAN KEY (15).

##### If no is chosen:

- a) Press the SCAN KEY (15) to advance to programming the setback mode.

##### If yes is chosen:

- a) The top display reads *HOLD*. The bottom display gives the current hold time. Press the TOGGLE/CLEAR KEY (11). Use the product keys to enter a hold time from 0 to 9 hours. Press the SCAN KEY (15) to enter the new hold time (HR:MN)..
- b) The top display reads *HOLD*. The bottom display gives the current hold temperature. Press the TOGGLE/CLEAR KEY (11). Use the product keys to enter a hold temperature from 140°F–210°F. Press the SCAN KEY (15) to enter the new hold temperature.
- c) The top display reads *H FAn*. The bottom display gives the current fan mode. To change the fan mode press the TOGGLE/CLEAR KEY (11). The bottom display toggles between *Hi* and *Lo*. Press the SCAN KEY (15) to enter the new fan mode and continue with programming the setback mode.

### Programming the setback mode

The setback mode operates as a power saving feature. After a period of non-use (the setback time) the oven temperature automatically decreases to the setback temperature. The oven will maintain this temperature until a product key is pressed. The minimum setback time is 20:00.

1. The top display reads *SEtb*. The bottom display gives the setback mode. To change the setback press the TOGGLE/CLEAR KEY (11). The bottom display toggles between *YES* and *no*. Press the SCAN KEY (15).

##### If no is chosen:

- a) The controller advances to programming the temperature mode.

##### If yes is chosen:

- a) The bottom display gives the current setback time. Press the TOGGLE/CLEAR KEY (11). Use the product keys to enter the desired setback time. Press the SCAN KEY (15) to enter the new setback time.
- b) The bottom display gives the current setback temperature. Press the TOGGLE/CLEAR KEY (11). Use the product keys to enter a setback temperature from 140°F–300°F. Press the SCAN KEY (15) to enter the new setback and continue with programming the temperature mode.

### Programming the temperature mode (°F or °C)

1. The top display reads *dEg*. The bottom display gives the units. To change the units press the TOGGLE/CLEAR KEY (11). The bottom display toggles between *F* and *C*.
2. Press the SCAN KEY (15) to enter the new temperature units and continue programming the shelf sensitivity.





### Programming the shelf sensitivity

The controller allows the user to program a sensitivity value (0–9) for each shelf position. The sensitivity value will shorten or stretch cook time depending upon shelf position.

*NOTE: SEN1 is the top shelf position, SEN5 is the bottom shelf position.*

1. The display reads SEN1.
2. Press the TOGGLE/CLEAR KEY (11) to clear the current value to the desired value. Use the product key numbers to input a new sensitivity value.
3. Press the SCAN KEY (15) to advance to the next shelf position, SEN2.
4. Repeat steps 2–3 for all five shelf positions.

### Exiting the programming mode

1. The top display reads SYS. Press the PROG KEY (10). The control returns to the operating mode.

### ERROR CODES AND ALARMS

*NOTE: The error codes will appear in the top display. All error codes are accompanied by an audible alarm.*

*Hi* Oven temperature is more than 40°F above the highest setpoint.

*Prob* Probe failure.

*HEAT ERR* From a cool start (below 140°F), the oven takes more than 10 minutes to climb from 150-300°F. Press the TOGGLE/CLEAR KEY (11) to clear the prompt. This code indicates a problem with the system. Contact a service technician.

*FAN ERR* Indicates a fan failure during a call for heat. Press the TOGGLE/CLEAR KEY (11) to clear the alarm. The FAN ERR display remains active. Press the TOGGLE/CLEAR KEY (11) again to clear the message and return the system to normal operation. If condition persists turn off the oven and contact a service technician.

*FANC ERR* Indicates a contact failure has occurred in the fan control circuit. Press the TOGGLE/CLEAR KEY (11) to clear the alarm. The FANC ERR display remains active. Press the TOGGLE/CLEAR KEY (11) again to clear the message and return the system to normal operation. If condition persists turn off the oven and contact a service technician.

*DOOR OPEN* The controller senses the door is open. Close the door. If the door is closed contact a service technician.



# Operation

## General Guidelines for Operating Personnel

### COOK TIMES AND TEMPERATURES

#### Preheating the oven

Always preheat the oven before baking or roasting. We recommend preheating 50°F (10°C) above the cook temperature to offset the drop in temperature when the doors are opened and cold product is loaded into the oven. Set the thermostat to the cook temperature after the product is loaded.

*NOTE: For frozen product, preheat the oven 100°F (38°C) above the cook temperature.*

#### Cook Temperatures

Generally, cook temperatures should be 50°F (10°C) lower than deck or range oven recipes. If the edges of the product are done but the center is raw, or if there is color variation, reduce the thermostat setting another 15–25°F (10–15°C). Continue to reduce the cook temperature on successive loads until the desired results are achieved.

*NOTE: Cooking at excessive temperatures will not reduce cook time, it will produce unsatisfactory baking and roasting results.*

#### Cook Time

Check the product in about half the time recommended for deck or range oven recipes. Record times and temperatures which provide best results for future reference.

*NOTE: Cook time will vary with the amount of product loaded, the type of pan and the temperature.*

### OPERATING TIPS

#### Pans and Racks

Product or pan height determines how many racks are used. The oven holds up to 10 18" x 26" (45.7 x 66.0 cm) bun pans.

Load the oven from the bottom, centering the pans on the rack. Never place a pan or aluminum foil on the bottom of the oven. This obstructs the flow of air and results in uneven baking and roasting.

#### Roasting

To reduce shrinkage when roasting, place meat directly on the racks. Place a sheet pan one-half full of water in the bottom rack position. The water evaporates, increasing humidity in the oven chamber. The pan catches grease from the meat, making oven cleaning easier.

#### Baking

Weigh the product to ensure equal distribution in each pan. Varying amounts of product will cause uneven baking results.

#### Fans

The fan must be operating for the oven to heat. Use the Pulse Plus feature to allow light or liquid product to set in the pan and to avoid rippling towards the fan. If your oven is not equipped with this feature use the following procedure.

1. Preheat the oven 25°F (15°C) above the baking temperature.
2. Load the oven with product. Close the doors.
3. Set the thermostat to the baking temperature.
4. Turn the oven off.
5. Allow the product to set for 5–7 minutes with the fan off. The residual heat in the oven sets the product.
6. Turn the oven on for the remainder of the bake.

#### Lights

Turn the oven lights off when not viewing the product. Leaving the lights on for extended periods of time shortens the bulb life considerably.



## Cleaning and Preventative Maintenance

### DAILY CLEANING

#### Oven Cool Down:

1. Turn the oven to *COOL DOWN*.

*NOTE: The doors may be opened to speed the cooling process.*

#### Cleaning the exterior

1. Saturate a cloth with a mild soap and water mixture. Wipe the oven when it is cold.
2. Dry the oven with a clean cloth.
3. Heat tint and heavy discoloration may be removed with any non-toxic, non-caustic, commercial oven cleaner and stainless steel polish.

#### Cleaning the interior

Deposits of baked on splatter may be removed with any non-toxic, non-caustic, food safe, commercial oven cleaner.

1. Apply cleaner following the manufacturer's direction. Always rub with the grain of the metal.

### WEEKLY CLEANING

1. Remove any loose debris or particle buildup from the racks, rack supports, baffle, blower wheel and temperature probe.

### MONTHLY CLEANING

#### Clean racks, rack supports, baffle and blower wheel

1. Remove the racks, rack supports and baffle.
2. Hold the blower wheel with a gloved hand.
3. Use an L-shaped brush to clean the fins on the blower wheel.
4. Use a hand brush to clean the center portion of the blower wheel.

5. Wipe around the fan with a damp towel.
6. Soak racks, supports and baffle in a solution of non-toxic, non-caustic, food safe, commercial oven cleaner. Allow to soak overnight if necessary.
7. Reinstall parts.

#### Clean temperature probe

1. Use a damp towel to wipe the probe. **Handle with care.**

#### Clean cooling fan

1. Brush off the cooling fan located on the back of the oven behind the control compartment.

### PREVENTATIVE MAINTENANCE

#### Annual Maintenance

The following checks should be part of an annual scheduled maintenance. **This maintenance must be performed by an authorized service agency.** Contact your local Blodgett service company, a factory representative or the Blodgett Oven company.

1. Check venting system.
2. Check temperature calibration.
3. Adjust and grease door switch for proper closure.
4. Clean any debris out of control tray. Check for loose connections. Replace any discolored connections.
5. Retorque all electrical connections between the element and contactors.



#### **WARNING!!**

**Always disconnect the appliance from the power supply before servicing or cleaning.**



# Maintenance

## Troubleshooting Guide

POSSIBLE CAUSE(S)	SUGGESTED REMEDY
SYMPTOM: Heating elements do not come on.	
<ul style="list-style-type: none"> <li>• Oven not plugged in.</li> <li>• Power switch on the control panel is off.</li> <li>• Control set below ambient temperature.</li> <li>• Doors are open.</li> <li>• Computerized controls – error code on display.</li> </ul>	<ul style="list-style-type: none"> <li>• Plug in electrical supply cord.</li> <li>• Set the control panel to COOK or OVEN ON.</li> <li>• Set to desired cook temperature.</li> <li>• Close doors.</li> <li>• *</li> </ul>
SYMPTOM: Oven does not come to ready.	
<ul style="list-style-type: none"> <li>• The oven has not reached preheat temperature.</li> <li>• Fan delay feature may be activated, if applicable.</li> <li>• Internal problem with main temperature control.</li> </ul>	<ul style="list-style-type: none"> <li>• Wait for oven to reach preheat temperature.</li> <li>• Deactivate fan delay feature.</li> <li>• *</li> </ul>
SYMPTOM: Convection fan does not run.	
<ul style="list-style-type: none"> <li>• Oven is not plugged in.</li> <li>• Oven is not set to the cook mode.</li> <li>• Circuit breaker tripped.</li> <li>• Fan delay feature may be activated, if applicable.</li> <li>• Doors are open</li> </ul>	<ul style="list-style-type: none"> <li>• Plug in electrical supply cord.</li> <li>• Set the control panel to COOK or OVEN ON.</li> <li>• Reset the breaker.</li> <li>• Deactivate fan delay feature.</li> <li>• Close doors.</li> </ul>
SYMPTOM: General baking problems.	
<ul style="list-style-type: none"> <li>• Computerized controls – incorrect product programming.</li> <li>• Thermostat out of calibration.</li> </ul>	<ul style="list-style-type: none"> <li>• Reprogram control per Operation section.</li> <li>• *</li> </ul>
<p>*Denotes remedy is a difficult operation and should be performed by qualified personnel only. It is recommended, however, that All repairs and/or adjustments be done by your local Blodgett service agency and not by the owner/operator. Blodgett cannot assume responsibility for damage as a result of servicing done by unqualified personnel.</p>	



### WARNING!!

**Always disconnect the power supply before cleaning or servicing the oven.**

**CUSTOMER  
INSERT  
WIRING DIAGRAM  
HERE**