

6500 K

Ceramic Glass Hob

User Instructions

Dear customer,

Please read these operating instructions through carefully. Above all, please observe the "Safety" section on the first few pages. Please retain these operating instructions for future reference. Pass them on to any subsequent owners of the appliance.



The warning triangle and/or specific words (**Warning!**, **Caution!**, **Important!**) are used to highlight information that is important for your safety or the function of the appliance. It is imperative that this information is observed.



1. This symbol guides you step by step through the operation of the appliance.
2. ...
3. ...



Next to this symbol you will find additional information and practical tips on using the appliance.



Tips and information about the economical and ecological use of the machine are marked with the clover.

In the event of a malfunction, these operating instructions contain information on how to rectify faults yourself, see the "What to do, if..." section.

If you require further assistance please contact your local AEG Service Force Centre, see the section "Service and Spare Parts"

Printed on paper manufactured with environmentally sound processes.
He who thinks ecologically, acts accordingly ...

CONTENTS

Operating Instructions	5
Safety	5
Disposal	7
The Key Features of Your Appliance	8
Appliance Description 6500 K	9
Control panel 6500 K	10
Mains "On/Off" button	10
Cooking zone selection	10
"Heat Setting/Residual Heat" display	10
Heat setting selection + and -	11
"Lock" button and indicator	11
Cooking zone safety switch	12
Resetting the safety switch	12
Before Using for the First Time	13
Cleaning for the first time	13
Operation of the Cooking Surface	13
TOUCH CONTROL sensor buttons	13
Switching on the appliance	13
Switching off the appliance	13
Cooking with the automatic warm up function	14
Cooking without the automatic warm up function	15
Locking/unlocking the control panel	16
Tables and Tips	17
Pans	17
Energy saving tips	17
Tips for cooking with and without the automatic warm up function	18
Cleaning and Care	20
Ceramic glass cooking surface	20
Stubborn Soilage	21

What to do if 23

Service and Spare Parts 26

Customer Care 26

Guarantee Conditions 27

Installation Instructions 28

Technical Data 28

Regulations, Standards, Directives 29

Installing and Connecting Up 30

Installing 30

Electrical connection 33

OPERATING INSTRUCTIONS

Safety

The safety aspects of this appliance comply with the accepted technical standards and the German Appliance Safety Law. However, we also consider it our obligation as a manufacturer to make you aware of the following safety information.

Electrical Safety

- The new appliance may only be installed and connected up by qualified personnel, according to the manufacturer's instructions and to the relevant British Standards.
Please observe this instruction, otherwise the warranty will not cover any damage that may occur.
- Repairs to the appliance should only be carried out by approved service engineers. Improper repairs can cause injury or significant malfunction. If your appliance needs repairing, please contact your local AEG Service Force Centre.
- If your appliance malfunctions, or fractures, cracks or splits appear:
 - switch off all cooking zones,
 - disconnect the hob from the electricity supply.

Child Safety

The cooking zones will become hot when you cook. Therefore, always keep small children away.

The hob is designed to be operated by adults. Do not allow children to play near or with the hob.

Safety During Use

- This appliance may only be used for normal cooking and frying in the home. It is not designed for commercial or industrial purposes.
- Do not use the hob to heat the room.
- Take care when plugging electrical appliances into mains sockets near the hob. Connecting leads must not come into contact with the hot surface.
- Overheated fats and oils catch fire quickly. You should supervise cooking when preparing foods in fat or oil (e.g. chips).
- Switch the cooking zones off after use.

Safety When Cleaning

- For safety reasons do not clean the appliance with a steam jet or high pressure cleaner.
- Clean the hob in accordance with the maintenance and cleaning instructions in this manual.

How to Avoid Damage to Your Appliance

- Do not use the hob as a work surface or for storage.
- Do not use the cooking zones with empty pans, or without pans.
- Ceramic glass is insensitive to temperature shock and very robust, however it is not unbreakable. Hard and sharp objects, in particular, can damage the cooking surface if they fall on it.
- Do not use cast iron pans or pans with damaged bases that are rough or burred. Scratching may occur when the pans are slid.
- Do not place any pans on the hob frame. Scratching may occur or the paint damaged.
- Ensure that liquids containing acids, e.g. vinegar, lemon or scale remover do not come into contact with the hob frame, otherwise matt spots will appear.
- If sugar or a dish containing sugar comes into contact with a hot cooking zone and then melts, remove the soiling immediately whilst still hot using a scraper. If it cools, damage to the surface may occur on removal.
- Keep all items and materials that can melt away from the ceramic glass surface, e.g. plastics, aluminium foil, or oven foils. If something of this nature should melt onto the ceramic glass surface, it must also be removed immediately using the scraper.
- If you wish to use special types of pan (e.g. a pressure cooker, simmering pan, wok, etc.), please observe the manufacturer's instructions.
- Avoid boiling pans dry. The bases could be irreparably damaged in the process and the glass ceramic cooking surface also damaged.



Disposal

Disposing of packaging material

All materials used can be recycled.

The plastics are marked as follows:

- >PE< for polyethylene, e.g. as used for the outer wrapping and the bags inside.
- >PS< for polystyrene foam, e.g. as used for the packing pieces, completely free of CFCs.

The cardboard is made from 80% recycled paper.

Disposal of old appliances

Please dispose of any old appliance with due regard to safety and the environment.





Warning! Before disposing of old appliances make them inoperable. Unplug from the mains, cut off the mains cable.



Information on disposal

- The appliance must not be disposed of in the household rubbish.
- You can obtain information about collection dates or public tips from your local refuse department or council.

The Key Features of Your Appliance

- **Ceramic Glass Cooking Surface:** the appliance has a VITRAMIC® cooking surface made of ceramic glass and 4 fast heating cooking zones. The particularly powerful radiant heater elements significantly shorten the amount of time taken for the zones to heat up.
- **Sensor Buttons:** your appliance is operated using TOUCH CONTROL sensor buttons.
- **Cleaning:** the advantage of glass ceramic cooking surfaces and the sensor buttons is their ease of cleaning. A damp cloth is often sufficient for cleaning. (see: "Cleaning and care")
- **Mains Button:** the appliance has a separate mains button. The "On/Off" button enables the electricity supply to the appliance to be completely switched off at the touch of a button.
- **Displays:** digital displays and indicators provide information on the heat setting chosen, the functions that are activated, and any heat remaining in the cooking zone.
- **Lock Button:** the appliance is also equipped with a lock button. The control panel can be completely locked using this button. In this way inadvertent change to the settings can be prevented.
- **Automatic Function:** your appliance is equipped with an electronically controlled automatic warm up function on all four cooking zones. The built-in function switches automatically from the maximum heat setting to the lower heat setting selected for further cooking.
- **Safety Switch:** a safety switch automatically switches off all the cooking zones when no changes have been made to the settings for a certain period of time.
- **Keep Warm Setting:**  is the heat setting at which food can be kept warm.
- **Residual Heat Indicator:**  illuminates in the display, if the cooking zone is sufficiently hot to cause burns.

Appliance Description 6500 K

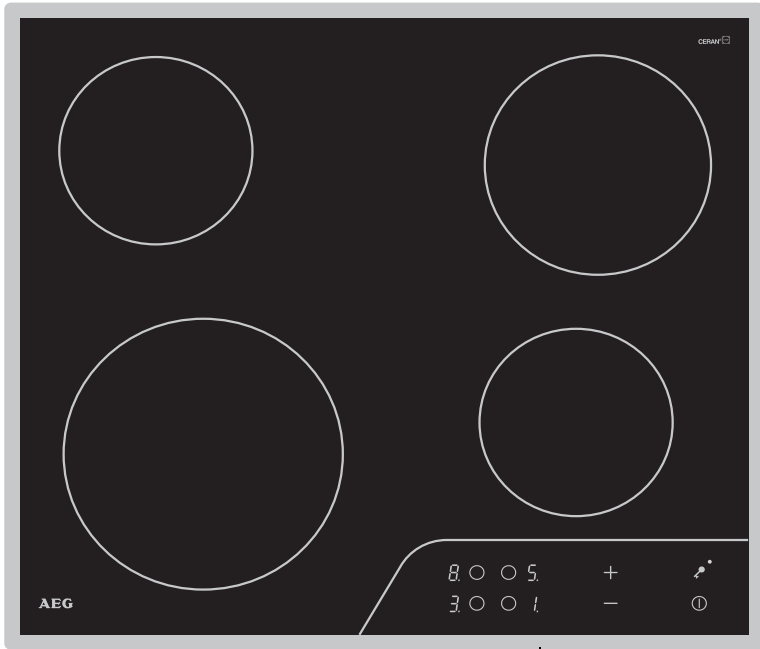

Cooking Zone Selection with Indicator

Heat Setting Selection "+" and "-"

"On/Off" and Lock

Cooking zone dimensions:

rear left: 145 mm
 rear right: 180 mm
 front left: 210 mm
 front right: 145 mm

Control panel 6500 K

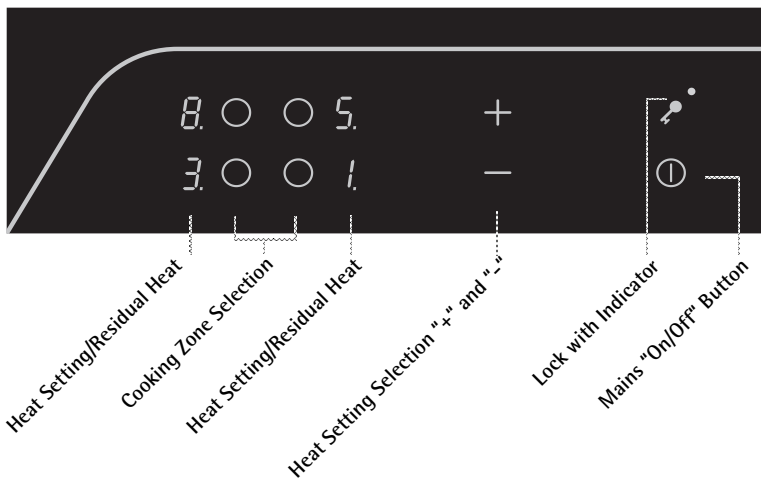

Mains "On/Off" button

For switching on the appliance. The appliance is:

- switched on when the button is touched for approx. one second,
- switched off when the button is touched again for one second.







When the appliance is switched on, at least one of the "Heat Setting/Residual Heat" displays is illuminated.

Cooking zone selection



Buttons for choosing the cooking zone on which the setting is to be changed. The decimal point is illuminated in the display field of the cooking zone just selected.



"Heat Setting/Residual Heat" display

The four display fields that are assigned to the four cooking zones display:

- , after switching on and when automatically switched off by the safety function,
-  to , depending on the heat setting chosen,
-  when the warm up function is active,
-  in the case of residual heat,
-  in the case of a fault.

Heat setting selection and

For setting or adjusting the heat setting ( to ) on the selected cooking zone.

- The heat setting is increased using the  button and the automatic warm up function activated.
- The heat setting is lowered using the  button.

“Lock” button and indicator

To lock the control panel against inadvertent changes to the settings, touch the button for approx. two seconds. The lock is lifted by touching the button again for two seconds.



The lock can also be used as a child safety measure.

The indicator illuminates when the control panel is locked.



Cooking zone safety switch

If, after a set period of time, one of the rings is not switched off or the heat setting not changed, the cooking zone switches off automatically.

, or  appears in the displays of all the rings that are switched on.

The rings are switched off at:

- Heat setting 1 - 2 after 6 hours
- Heat setting 3 - 4 after 5 hours
- Heat setting 5 after 4 hours
- Heat setting 6 - 9 after 1.5 hours

Resetting the safety switch

 To release the safety switch on **all** cooking zones switched on, switch the appliance off and on again at the main button. The cooking zones are then ready for use again.



 appears in the ring display when there is still heat remaining.

Before Using for the First Time

Cleaning for the first time

Wipe the ceramic glass cooking surface with a damp cloth to remove any traces left from manufacturing.



Important: Do not use any caustic, abrasive cleaners! The surface could be damaged.

Operation of the Cooking Surface

TOUCH CONTROL sensor buttons

To operate the TOUCH CONTROL sensor buttons, place your finger flat on the desired button until the corresponding indicator illuminates, or extinguishes, or the desired function is performed.

For quicker adjustment leave your finger on the button until the desired value is reached.

All entries are confirmed by an acoustic signal.

Switching on the appliance



Switch on the appliance using the main "On/Off" button.

The "Heat Setting/Residual Heat" display fields indicate .



After the main "On/Off" button has been operated to switch on your appliance, one of the cooking zones must be selected using the cooking zone selection buttons within approx. 10 seconds. Otherwise the appliance switches off again for safety reasons.

Switching off the appliance



Operate the main "On/Off" button to completely switch off the appliance.



After the individual cooking zones or the entire cooking surface have been switched off, the presence of residual heat is indicated by  (as in "Hot") in the "Heat Setting/Residual Heat" display fields of the respective cooking zones.

If all cooking zones are switched off, the appliance switches off automatically after a period of time.

Cooking with the automatic warm up function

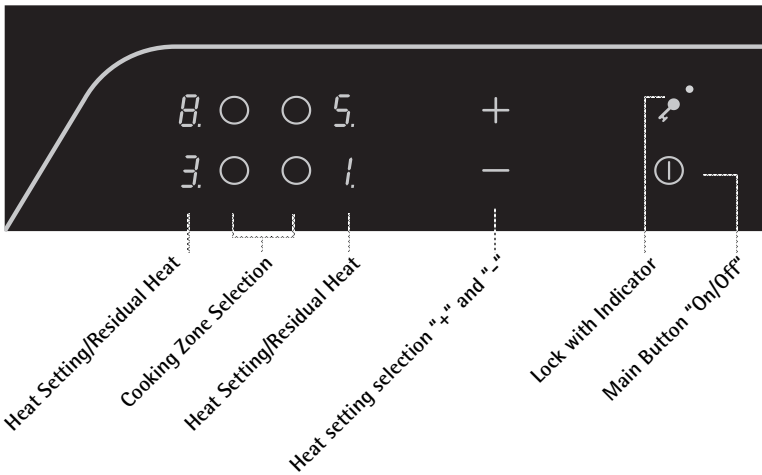

All four rings on the cooking surface have nine heat settings and are equipped with an automatic warm up function.

- [1], lowest heat setting
- [9], highest heat setting
- [8], automatic warm up function.

When you select the heat setting that you require for cooking, using the [8] button, once the pan is hot, the cooking zone operates for a certain period of time at full power ([9] = automatic warm up function) and then switches back to the heat setting selected for further cooking. The duration of the automatic warm up period is dependent on the setting chosen for further cooking once the pan is hot!

1. Select the desired cooking zone using the cooking zone buttons.
The decimal point in the associated display field illuminates.
2. Press the [8] button, until the required heat setting [1] to [9] is reached. The cooking setting chosen is then displayed. After 5 seconds, [8] appears again in display instead of the cooking setting.
The cooking setting is displayed again at the end of the automatic warm up time.



If you select a higher setting when the automatic function is in operation, e.g. from **3** to **5**, the previous warm up time is taken into account. If you select a lower setting, then the automatic warm up function is brought to an immediate end. If you start cooking again on a cooking zone that is still warm, the automatic warm up function uses the residual heat. This saves time and energy.

Switching off a cooking zone

-  1. Select the desired cooking zone using the cooking zone buttons.
2. Press the **+** and **-** buttons simultaneously to switch off.

Cooking without the automatic warm up function

If you want to use the cooking zone without the automatic warm up function, then select the desired heat setting with the **-** button.

Select a high setting for warming up. As soon as steam starts to form or the oil is hot, turn back to the heat setting necessary for further cooking.

-  1. Switch on the appliance and select the desired cooking zone using the cooking zone selection buttons.
The decimal point in the associated display field illuminates.
2. Press the **-** button to set the required heat setting **1** to **9**.
The "Heat Setting/Residual Heat" display field for the corresponding cooking zone indicates the current setting.
3. You can adjust the heat setting at any time using the **+** and **-** buttons, as long as the cooking zone is selected.

Switching off a cooking zone

-  1. Select the desired cooking zone using the cooking zone buttons.
2. Press the **+** and **-** buttons simultaneously to switch off.



If you want to switch on again a cooking zone on which there is food that is already hot, you should always choose the required heat setting using the **-** button. In this way you will avoid the food being overcooked by the automatic warm up function.

Locking/unlocking the control panel

At any time during the cooking process, the control panel can be locked, with the exception of the "On/Off" button. By this means accidental changes to the settings can be prevented. This function is also useful as a child safety measure.

1. Touch the  button until the indicator illuminates.
2. To unlock, touch the lock button again until the indicator extinguishes.

Child safety! If, the lock button is active when the cooking surface is completely switched off by touching the main button, when the cooking surface is switched on again, the lock button is active. This means that the lock button must be operated first, before the rings can be switched on again.

Tables and Tips

Pans

The better the pan, the better the results.

- You can recognise good quality pans by the base of the pan.
- The base should be as thick and flat as possible. Rough bases (e.g. on cast iron pans) will scratch the cooking surface when slid.
- Use **high sided pans for dishes with a lot of liquid, so that nothing boils over.**
- Ensure that the pan is in the centre of the cooking zone and covers the heated/marked area.



Important! Avoid pans boiling dry. The base could be damaged and then scratch the cooking surface when slid. Saucepans and frying pans with sharp edges and burrs will also scratch.

Energy saving tips



You will save valuable energy if you observe the following tips:

- Whenever possible, use the automatic warm up function on your cooking zones (see "Cooking and Frying Table").
- Observe the special tips on saucepans and frying pans. **The pan base and cooking zone** should be the same size.
- Dirty cooking zones and pan bases damage the glass ceramic cooking surface and increase electricity consumption.
- Switch the cooking zone off before cooking is finished to use the residual heat.
- Cooking times are reduced by up to 50% when a pressure cooker is used. Not only do you save energy, but more vitamins and minerals are retained.

You will waste energy if the....

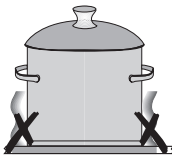

Pan is too small

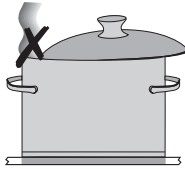

Pan lid is not fitted properly

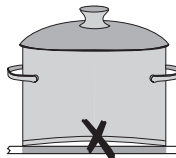

Pan base is uneven

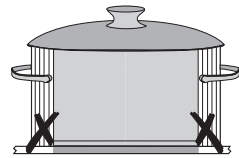

Pan is too large (glass ceramic)

Tips for cooking with and without the automatic warm up function

The automatic warm up function is suitable for:



- dishes that start off cold, are heated up at a high setting and do not need to be continually watched when cooking,
- dishes that are put in a hot frying pan.

The automatic warm up function is not suitable for:

- goulash and similar braised dishes that need continual turning until browned correctly, liquid adding and then braising until cooked,
- dumplings, pasta dishes with large amounts of liquid,
- cooking with pressure cookers,
- very large quantities of soup/stew with more than 2 litres of liquid.

General notes:



- When cooking without the automatic warm up function, we recommend the use of a high heat setting to warm up the food (using the  button) and then leaving the dish to finish cooking at an appropriate lower heat setting.
- You can use the  heat setting for keeping food warm.
- Take note of the results when you initially use the appliance. You can then decide which heat setting is the best for "your dishes" in the "quantities you are accustomed to preparing" with "your pans". You will then rapidly come to value the merits of the automatic function and will feel at ease with you new cooking surface.

Typical Heat Settings

The figures given in the following tables are for guidance only. Exactly which heat setting needs to be used depends on the quality of the pans and the type and quantity of the food.

Table: Cooking and Frying

Switch Setting	Automatic Warm Up Time* (Min.)	Cooking Process	Examples of Usage
9		Warming Up Browning Frying	Warm up large amounts of liquid, boil pasta, brown meat, (brown goulash, pot-roast)
8	4.5	Fast Frying	Steaks, pieces of loin, potato fritters, fried sausages, pancakes
7	3.5		
6	2.5	Gentle Frying	Schnitzel/cutlets, liver, fish, rissoles, fried eggs
5	8.5	Boiling	Boiling potatoes, vegetables
4	6.5		
3	4.8		
2	3.0	Steaming Softening	Steam and sauté small quantities of vegetables, cooking rice and milk based dishes
1	1.0	Keeping warm Melting	Keep food warm, melt butter, dissolve gelatine, melt chocolate

*) When cooking without the automatic warm up function, the warm up time can be selected as required.

Cleaning and Care

Ceramic glass cooking surface

It is important to clean the cooking surface after each use.



Important! Never use aggressive cleaners such as, for example, coarse scouring cleaners or pan cleaners that scratch.

-  1. Always clean the cooking surface after each use. Use a damp cloth and a little washing up liquid.
Then rub the cooking surface dry with a clean cloth. No residues of cleaner must be left on the surface.
2. Clean the entire cooking surface thoroughly once a week. For cleaning use "Stahl-Fix" or "Vitroclen".
3. Then rinse the entire cooking surface with plain water and rub it dry with a clean cloth.
Ensure that no remnants of cleaner are left on the surface! Otherwise the cooking surface will be damaged!
Only use the recommended cleaners.

Stubborn Soilage

Residues from food that has boiled over

First soften these using a wet cloth and then remove residues using a glass scraper.



Caution! Take care when using a glass scraper.

Then clean the cooking surface with the recommended cleaners.

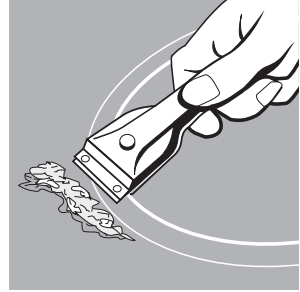

Sugar



Warning! Remove burnt on sugar or melted plastic immediately - **when still warm** (not hot) - using a glass scraper, otherwise damage may be caused to the hob.

Then clean the cooking surface normally. Damage from sugar or food containing sugar can be avoided by polishing the cooking surface with "Vitroclen".



Spots

Scale, shiny pearl like spots, metallic iridescent coloured spots, and food remnants from pans that have formed during cooking are best removed when the cooking zones are **still warm**.

Use the cleaners and polishes recommended. If necessary, clean more than once.

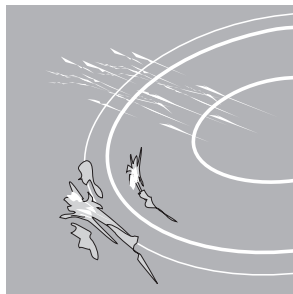

Acids



Important! Do not put vinegar, lemons or scale removers on the recess frame, they will make the surface matt.

Grains of sand that have fallen on the cooking surface can cause scratching when pans are slid. Therefore make sure that no grains of sand are left on the cooking surface.



Abraded decor



Important! If aggressive cleaners or pans with abrasive bases are used, then the decor will take on an abraded appearance and dark spots will appear over time.

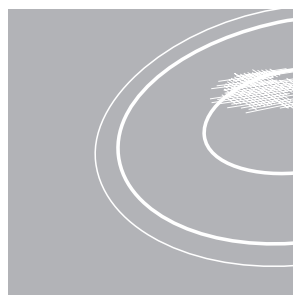

You can obtain suitable cleaners and polishes as well as glass scrapers from AEG Service Force Centre.

What to do if ...

A fault may have been caused by a minor operating error, which you can correct yourself with the help of the following instructions. Do not attempt any further repairs if the following instructions do not help in the specific case.



Warning! Repairs to the appliance should only be carried out by approved service engineers. Improper repairs can cause injury or malfunction. If your appliance needs repairing, please contact your local AEG Service Force Centre.

What to do if ...

.... the cooking zones do not work?



Check whether

- the mains fuse (fuse box) is intact. If the fuse blows several times, please call an approved electrician.
- that the appliance is correctly connected and is switched on,
- indicators on the control panel illuminate,
- the corresponding cooking zone is switched on,
- the cooking zones are set to the desired heat setting for cooking (see section: "Cooking").
- the cooking zones have been switched off by the safety switch (see section: "Safety Functions").

.... the cooking zones cannot be switched on?



Check whether

- the control panel is locked (see section: "Locking/Unlocking the Control Panel").
- more than 10 seconds have elapsed between operating the On/Off button and switching on the desired cooking zone, (see section: "Switching on the Appliance").
- the touch switches are partially covered by a damp cloth or liquid.

.... the cooking zones do not heat up, even though the displays are working?



Check whether

- demonstration mode has been activated accidentally.

To deactivate this mode, ensure that the appliance is switched off and that the control panel is not locked.



Then proceed as follows:

1. Switch on main button.
2. Within 10 seconds, press the following buttons simultaneously for a maximum of one second:
 - lock button 
 - cooking zone selection button, front left
 - cooking zone selection switch, rear left.

When the buttons are released, a peep tone sounds as confirmation.

3. Press the  button, a peep tone sounds as confirmation.

Your cooking surface is now ready for use again.

.... the display suddenly changes to  or  for residual heat?



Check whether

- the On/Off button has been operated accidentally.
- the touch switches are partially covered by a damp cloth, liquid or similar.
- there has been a power cut.
- the safety switch has been activated.

.... after switching off the cooking zones, neither  nor  for residual heat appears in the display?



Check whether

- the cooking zone was only used for a short period and is therefore not hot enough.

If the cooking zone is hot, call AEG customer service.

.... a cooking zone cannot be switched off?



Check whether

- the touch switches are partially covered by a damp cloth or liquid.
- the lock is activated.

.... a cooking zone cannot be switched on?



Check whether

- the lock is activated.

....  is shown in the display?

Check whether

- a pan that is too small is on the cooking zone.
- the cooking zone has been overheated.

If a cooking zone button is pressed and the pan on the cooking zone is too small,  (Fault) appears in the display. This symbol is also displayed in the case of overheating, faults in the electronics or for safety reasons.

Important! If you call an engineer to resolve a problem listed in these notes, or to rectify an error caused by incorrect use or installation, a charge will be made even during the guarantee period.

SERVICE AND SPARE PARTS

In the event of your appliance requiring service, or if you wish to purchase spare parts, contact your local AEG Service Force Centre by telephoning

08705 929 929

Your call will be automatically routed to the Service Centre covering your post code area.

Please ensure that you have read the section 'What to do if...!' as the engineer will make a charge if the fault is not a mechanical or electrical breakdown even the appliance is under warranty.

Please note that proof of purchase is required for in-guarantee service calls.

Help us to help you

Please determine your type of enquiry before writing or telephoning.

When you contact us we need to know:

- Your name,
- Address and post code.
- Telephone number
- Clear and concise details of the fault.
- Name and model of the appliance*
- E number *

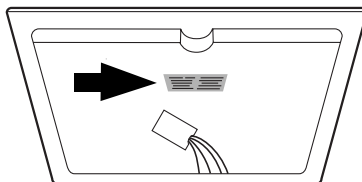

*This information can be found on the rating plate.

Customer Care

For general enquiries concerning your AEG appliances, or for further information on AEG products, please contact our Customer Care Department.

Customer Services Department
AEG Domestic Appliances
55-77 High Street
Slough
Berkshire
SL1 ID2
Tel.: 08705 350 350

GUARANTEE CONDITIONS

Guarantee Conditions

AEG offer the following guarantee to the first purchaser of this appliance.

1. The guarantee is valid for 12 months commencing when the appliance is handed over to the first retail purchaser, which must be verified by purchase invoice or similar documentation.

The guarantee does not cover commercial use.

2. The guarantee covers all parts or components which fail due to faulty workmanship or faulty materials. The guarantee does not cover appliances where defects or poor performance are due to misuse, accidental damage, neglect, faulty installation, unauthorised modification or attempted repair, commercial use or failure to observe requirements and recommendations set out in the instruction book.

This guarantee does not cover such parts as light bulbs, removable glassware or plastic.

3. Should guarantee repairs be necessary the purchaser must inform the nearest customer service office (manufacturer's service or authorised agent). AEG reserves the right to stipulate the place of the repair (i. e. the customer's home, place of installation or AEG workshop).
4. The guarantee or free replacement includes both labour and materials.
5. Repairs carried out under guarantee do not extend the guarantee period for the appliance. Parts removed during guarantee repairs become the property of AEG.
6. The purchaser's statutory rights are not affected by this guarantee.

European Guarantee

If you should move to another country within Europe then your guarantee moves with you to your new home subject to the following qualifications:

- The guarantee starts from the date you first purchased your product.
- The guarantee is for the same period and to the same extent for labour and parts as exist in the new country of use for this brand or range of products.
- This guarantee relates to you and cannot be transferred to another user.
- Your new home is within the European Community (EC) or European Free Trade Area.
- The product is installed and used in accordance with our instructions and is only used domestically, i. e. a normal household.
- The product is installed taking into account regulations in your new country.

Before you move please contact your nearest Customer Care Centre, listed below, to give them details of your new home. They will then ensure that the local Service Organisation is aware of your move and able to look after you and your appliances.

France	Senlis	+33 (0) 44 62 29 29
Germany	Nürnberg	+49 (0) 911 323 2600
Italy	Pordenone	+39 (0) 1678 47053
Sweden	Stockholm	+46 (0) 8 738 7910
UK	Slough	+44 (0) 1753 219899

INSTALLATION INSTRUCTIONS



Important! This appliance must be installed by qualified personnel, according to the manufacturer's instructions and to the relevant British Standards.

Please observe this instruction, otherwise the warranty will not cover any damage that may occur.

Technical Data

Appliance Dimensions

Width	570 mm
Depth	500 mm
Height	55 mm

Cut-Out Dimensions

Width	560 mm
Depth	490 mm
Corner radius	R3

Power Consumption

Front left cooking zone	2300 W
Rear left cooking zone	1200 W
Rear right cooking zone	1800 W
Front right cooking zone	1200 W

Heater Element Voltage	230 V ...240 V
-------------------------------	----------------

Total Electrical Load Max.	6.5 kW
-----------------------------------	--------

Fuse Rating	30 Amp
--------------------	--------

Regulations, Standards, Directives

This appliance meets the following standards:

- EN 60 335-1 and EN 60 335-2-6

in respect of the safety of electrical appliances for household use and similar purposes and

- DIN 44546 / 44547 / 44548

in respect of properties of electrical cookers for the household.

- EN 55014-2 / VDE 0875 part 14-2
- EN 55014 / VDE 0875 part 14/12.93
- EN 61000-3-2 / VDE 0838 part 2
- EN 61000-3-3 / VDE 0838 part 3

in respect of basic electromagnetic compatibility (EMC) requirements.

CE This appliance complies with the following EC directives:

- 73/23/EWG dated 19.02.1973 (Low Voltage Directive)
- 89/336/EWG dated 03.05.1989 (EMC Directive, including Amendment Directive 92/31/EWG).

Installing and Connecting Up

Installing



Important: The new appliance may only be installed and connected up by an **approved installer**.

Please observe this instruction, otherwise the guarantee will not cover any damage that may occur.

The veneer or plastic coverings on kitchen units around the appliance must be bonded with heat resistant adhesive (100 °C). If plastic coverings or the adhesive are not sufficiently temperature resistant, then the covering may distort or come loose.

In respect of fire protection, the appliance corresponds to **type Y** (EN 60335-2-6). Only this type of appliance may built into positions with a high cupboard or wall on one side.

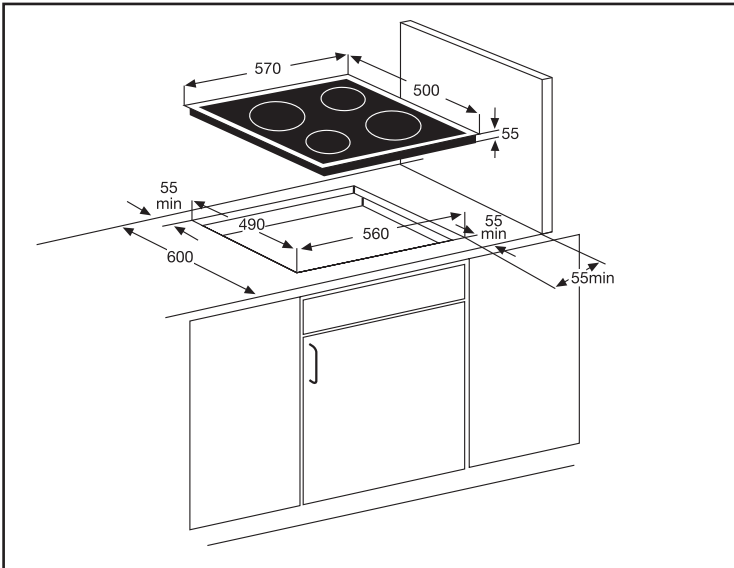

The cooking surface must have a heat protective base permanently fixed in position. The distance from the base to the underside of the cooking surface must be at least 50 mm. The edges of the cut out must be coated with a water-proof material. The cooking surface must be built-in such that the TOUCH CONTROL control panel is at the front (see Fig.).

- For protection against moisture, all cut faces are to be sealed with suitable sealing material.
- On tiled work surfaces, the joints in the area where the hob sits must be completely filled with grout.
- On natural, artificial stone, or ceramic tops, the snap action springs must be bonded in place.
- Ensure that the seal is correctly seated in the frame and that it is seated against the work surface without leaving any gaps. Additional silicon sealant must not be applied, this will make removal more difficult in the event of the need for service.
- To remove the hob, it must be pressed out from below.

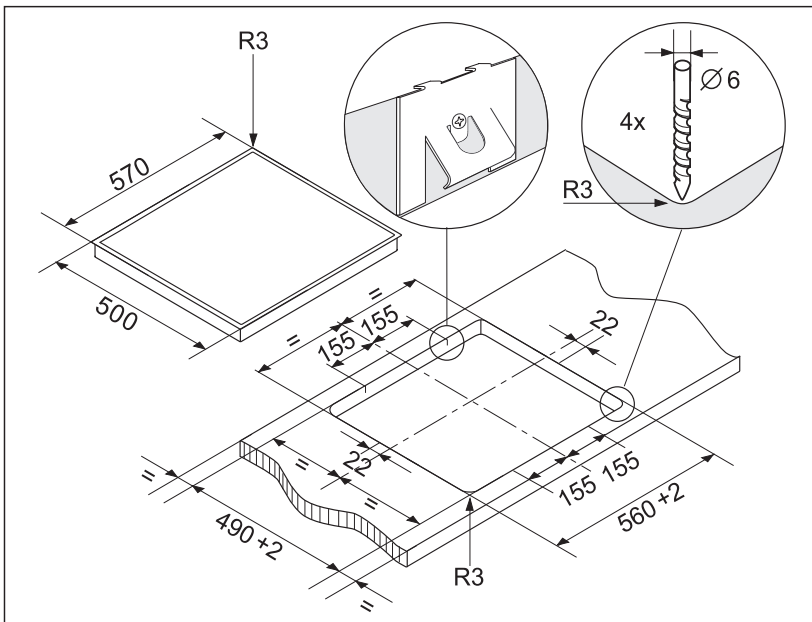

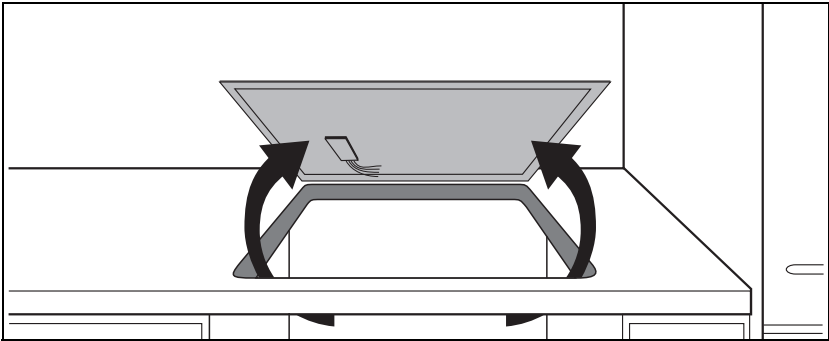
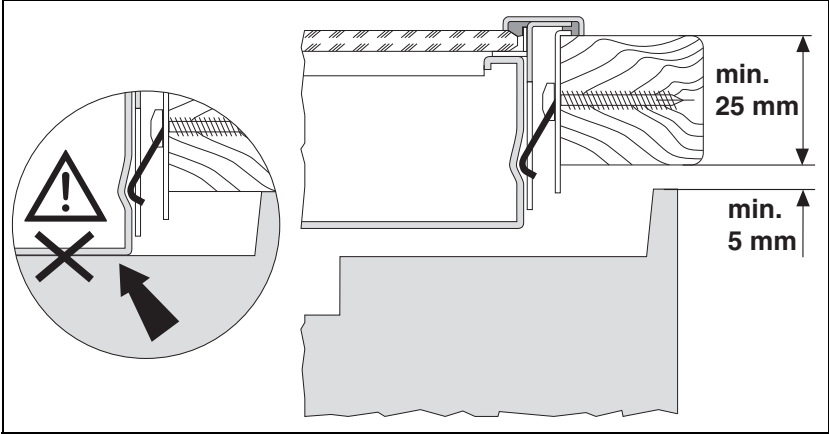

Electrical connection

Assembly and connection of the new appliance may only be performed by an **approved installer**.

Please observe this instruction, otherwise the guarantee will not cover any damage that may occur.



Attention! Only the cable fitted to the cooking surface recess may be used for connecting up the appliance. Replacement cables can only be obtained from AEG Service Force Centre. Part No. 374 349 000

A device is to be included in the electrical installation that makes it possible to isolate the appliance from the mains supply with a minimum contact separation of 3 mm. Suitable isolation devices include, e.g. cut-outs, fuses (screw type fuses are to be removed from the holder), earth leakage trips and contactors.

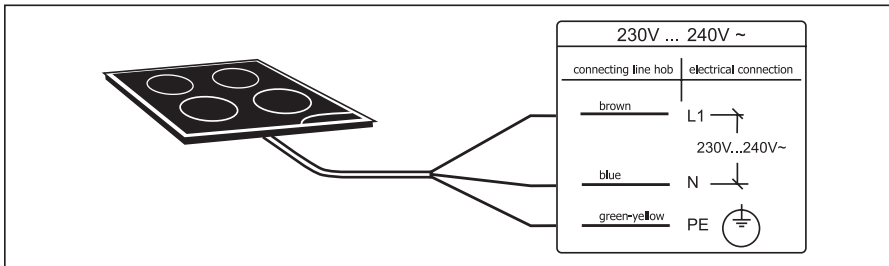

Important! Make the electrical connection in accordance with the wiring diagram.

Hier Typschild aufkleben!

(nur für Werk)

AEG Hausgeräte GmbH
Postfach 1036
D-90327 Nuremberg

<http://www.aeg.hausgeraete.de>

© Copyright by AEG

ANC 822 947 294 -03- 0899