

OWNER'S MANUAL
INSTALLATION INSTRUCTIONS

WINEGARD[®]
RV DIGITAL SATELLITE SYSTEM
Models RD-4600 & RD-1046
U.S. PATENTS PENDING

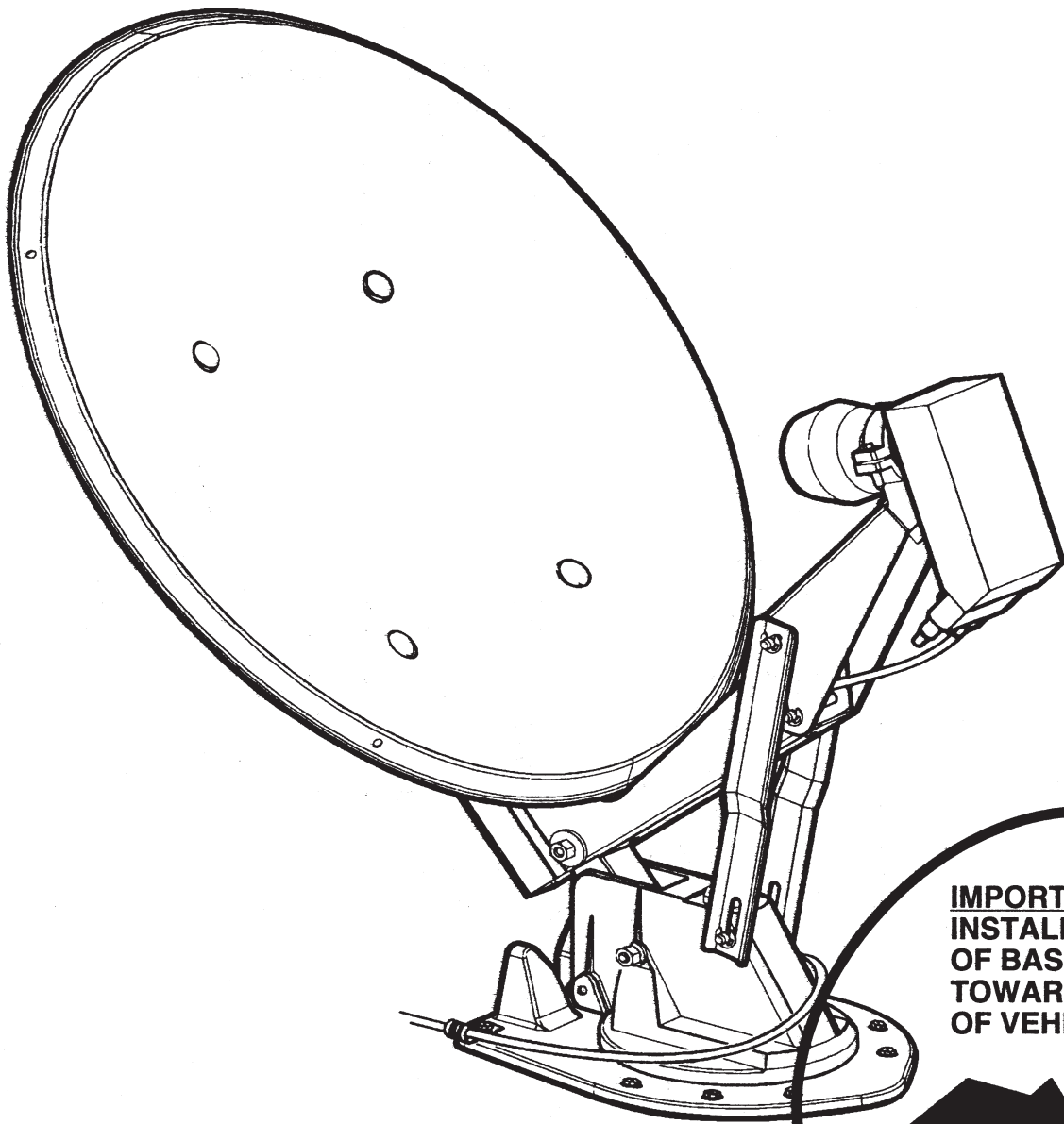

**IMPORTANT:
INSTALL POINT
OF BASE
TOWARD FRONT
OF VEHICLE!**



DSS[®] is a registered trademark of DIRECTV, Inc.,
a unit of GM Hughes Electronics.

INSTALLATION & ASSEMBLY

STEP 1: Choose location for antenna that will allow it to rest in travel position with antenna pointing toward rear of vehicle and raise and rotate without interfering with other roof-mounted equipment. Make sure inside ceiling area is clear where ceiling plate will mount.

NOTE: Figure 1 shows minimum distance (10") mount should be located from edge of vehicle roof. We recommend you check with your dealer or the manufacturer to see what provisions have been made in the roof for antenna mounting. A reinforced area of roof as well as downlead wiring may be available.

NOTE: *The system must be level for proper operation.* If you have a curved roof you should use a Winegard Model RW-1000 wedge kit to level the system.

STEP 2: Position template on roof (last page of manual) and drill a 1-1/2" hole through roof and ceiling of vehicle. Take care to avoid damage to wiring which may run between roof and ceiling.

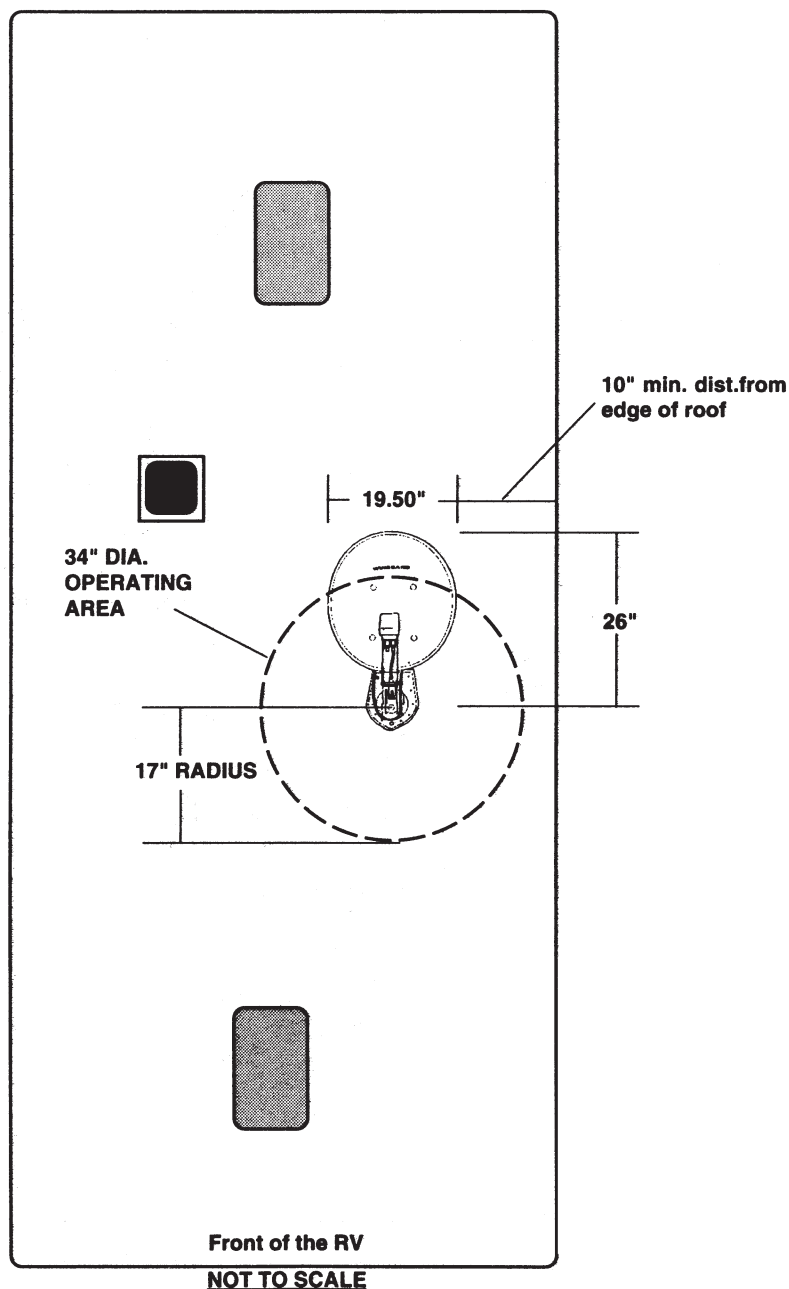

FIGURE 1

STEP 3: The mount is designed to fit roofs 1" to 4" thick. If roof is less than 4" thick, cut elevating shaft and directional handle to size, see table below. If roof is more than 4" thick (max. 6"), a longer directional handle is required.* If the roof is more than 4-3/4" thick, a longer elevating shaft is required.*

ROOF THICKNESS	ELEVATING SHAFT LENGTH	W/RW-1000	DIRECTIONAL HANDLE LENGTH
→ 4 3/4"	NO CHANGE	6 3/4"	5 5/16"
→ 4 1/2"	6"	6 1/2"	5 1/16"
→ 4 1/4"	5 3/4"	NO CHANGE	4 13/16"
4"	5 1/2"	6"	NO CHANGE
3 3/4"	5 1/4"	5 3/4"	4 5/16"
3 1/2"	5"	5 1/2"	4 1/16"
3 1/4"	4 3/4"	5 1/4"	3 13/16"
3"	4 1/2"	5"	3 9/16"
2 3/4"	4 1/4"	1 3/4"	3 5/16"
2 1/2"	4"	4 1/2"	3 1/16"
2 1/4"	3 3/4"	4 1/4"	2 13/16"
2"	3 1/2"	4"	2 9/16"
1 3/4"	3 1/4"	3 3/4"	2 5/16"
1 1/2"	3"	3 1/2"	2 1/16"
1 1/4"	2 3/4"	3 1/4"	1 13/16"
1" min.	2 1/2"	3"	1 9/16"

* → Requires RP-4002 Thick Roof Kit. Refer to page 13.

STEP 4: Attach reflector to backup assembly as shown in Figure 2.

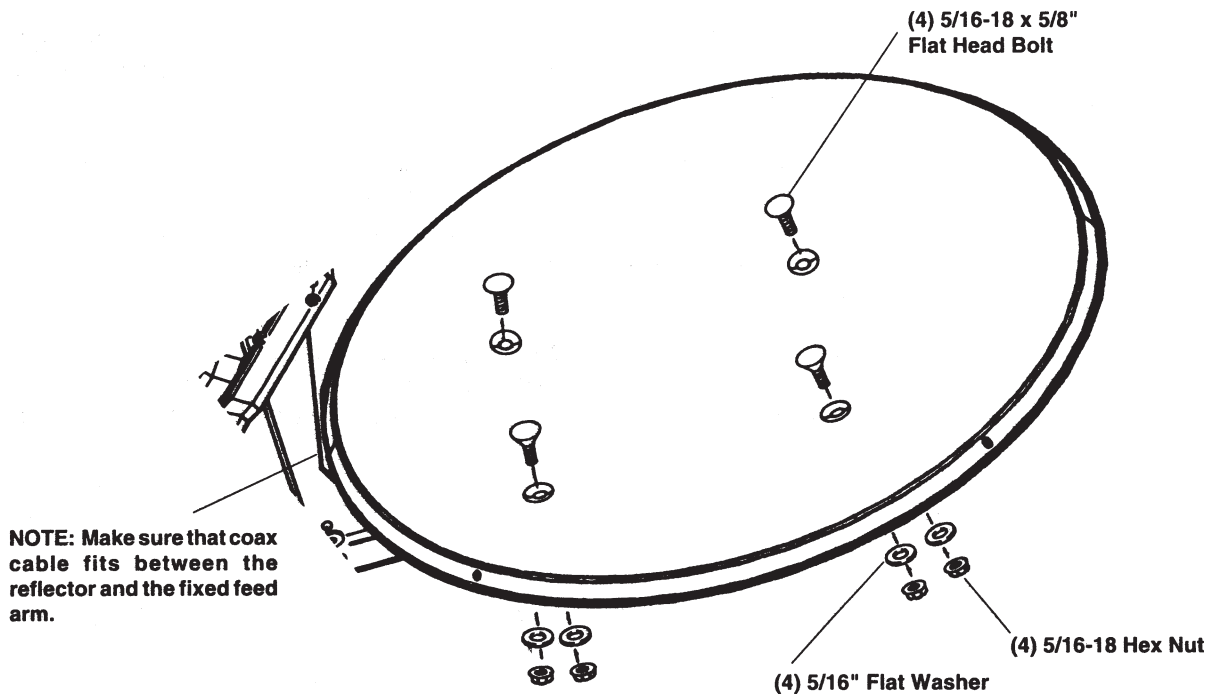

FIGURE 2

STEP 5: Mount antenna and lift on roof in travel position. Apply a liberal amount of approved nonhardening sealing compound on bottom of base plate and roof area around hole. See Figure 3. Secure base plate with screws provided, except for screw indicated in Figure 3.

CAUTION: DO NOT GET SEALING COMPOUND ON BEARING SURFACE BETWEEN BASE PLATE AND ROTATING GEAR HOUSING. DO NOT PAINT TOP OF BASE PLATE OR AROUND ROTATING GEAR HOUSING.

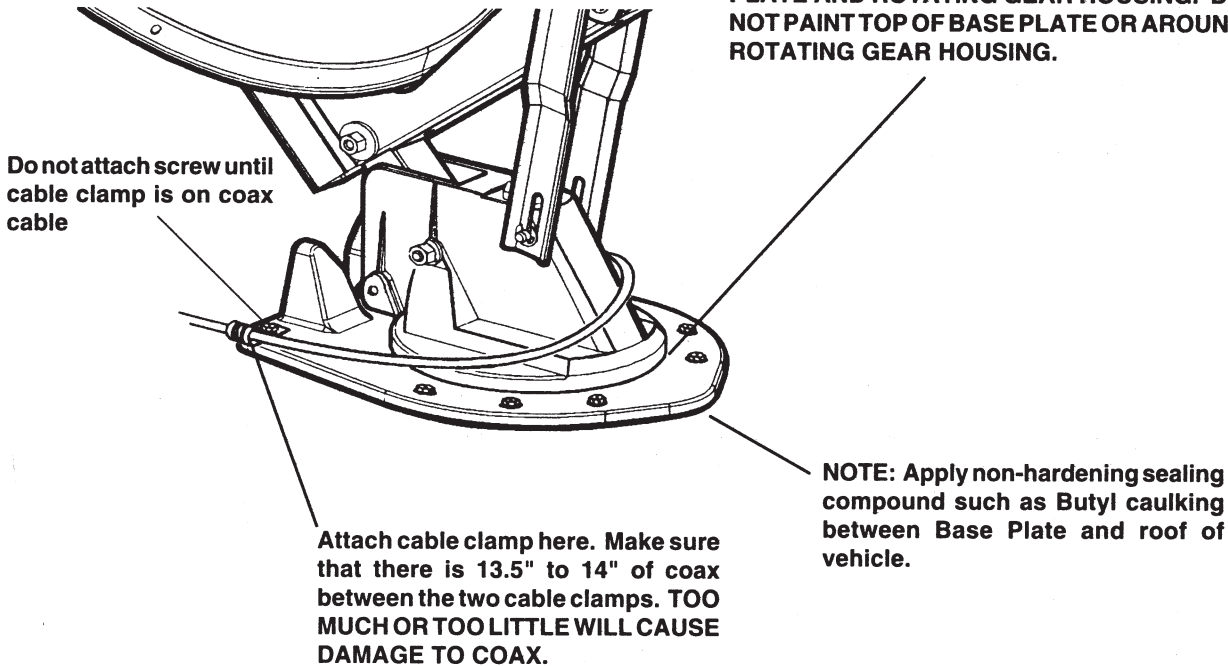

FIGURE 3

STEP 6: Attach cable clamp to the coax cable 13.5" from the cable clamp on the gear housing.

STEP 7: Attach cable clamp to baseplate as shown in Figure 3, use 7/16" flat washer between screw and strain relief. Apply sealing compound over mounting screw heads.

STEP 8: Attach downlead to antenna coax cable, feed downlead through the roof. Weather proof downlead entry. Secure downlead as necessary to prevent whipping.

STEP 9: Assemble ceiling plates, directional handle and crank handle as shown in Figure 4. The circled numbers indicates placement from the ceiling down. Example: The ceiling plate is located next to the ceiling. The elevation crank handle is farthest from the ceiling. The number also indicates sequence of assembly.

CAUTION: USE CAUTION WHEN INSTALLING THE ELEVATING CRANK. ONCE SET SCREW TOUCHES SHAFT, TIGHTEN ONLY 1/4 TURN MORE. SET SCREW SIMPLY HOLDS ELEVATING CRANK ON. DO NOT OVERTIGHTEN!

CAUTION: AFTER INITIAL INSTALLATION THE ANTENNA SHOULD ONLY ROTATE APPROXIMATELY 360° COUNTER CLOCKWISE. IF JUST THE OPPOSITE, REASSEMBLE CEILING PLATES WITH ROTATE STOP ON OTHER SIDE OF ROTATE PLATE STOP PIN (THIS PIN STOPS ANTENNA FROM ROTATING TOO FAR AND DAMAGING COAX DOWNLEAD).

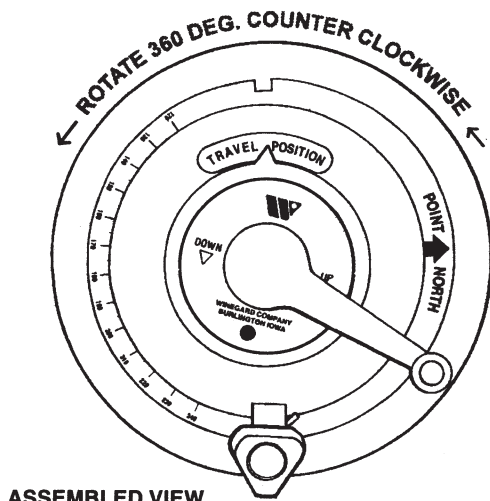

↓

CLAMP KNOB POINTS TO FRONT OF RV

CAUTION: THE ANTENNA MUST BE IN THE TRAVEL POSITION BEFORE ALIGNING THE DIRECTIONAL HANDLE, ROTATE PLATE, AND CEILING PLATE.

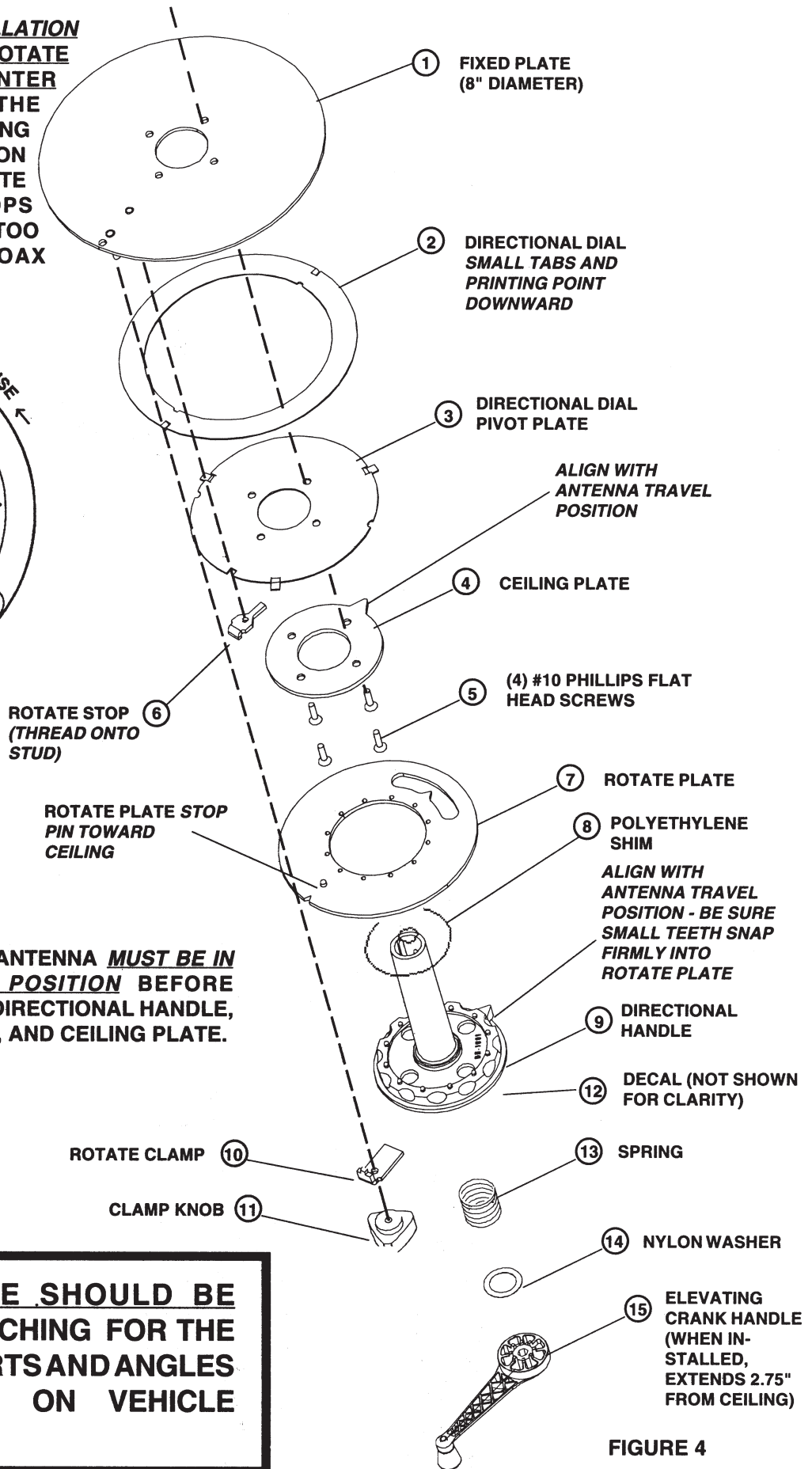

REMINDER: VEHICLE SHOULD BE LEVEL BEFORE SEARCHING FOR THE SATELLITE. ALL CHARTS AND ANGLES GIVEN ARE BASED ON VEHICLE BEING LEVEL.

FIGURE 4

OPERATION

STEP 1: Using a compass determine which direction is North. It is recommended that you step outside to perform this step. Standing in or near coach/RV can give you an incorrect reading. The more accurate your northern position the easier it will be to find the satellite(s).

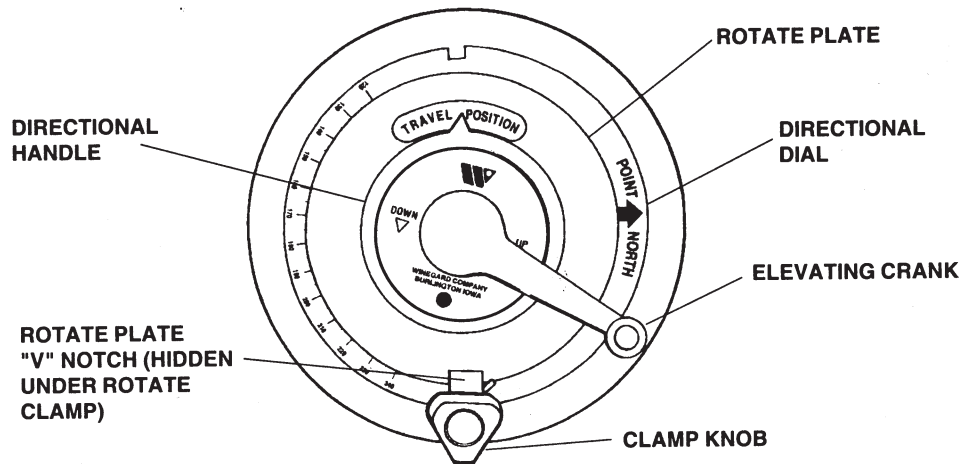

FIGURE 5

STEP 2: Loosen the clamp knob. See Figure 5.

STEP 3: Rotate directional dial (see Figure 5) until the arrow is pointing North.

STEP 4: Turn elevating crank (clockwise) in "UP" direction about 13 turns or until some resistance is met.

STEP 5: Turn receiver ON, and access installation menus to determine antenna elevation and direction/heading.

STEP 6: Turn directional handle until "V" notch in rotate plate is pointing in direction indicated by the receiver. Example: If receiver says point antenna at 145° then rotate directional handle so that "V" notch in rotate plate is pointing at 145° on the directional dial.

STEP 7: Refer to table below and turn elevation crank counter clockwise (CCW) the number of turns indicated to get the elevation shown by the receiver. One full turn equals approximately 7° of elevation change.

ELEVATION	TURNS CCW
24 - 26°	NONE
27 - 29°	1/2
30 - 32°	1
33 - 36°	1-1/2
37 - 39°	2
40 - 43°	2-1/2
44 - 46°	3
47 - 50°	3-1/2
51 - 53°	4
54 - 57°	4-1/2
58 - 60°	5
61 - 64°	5-1/2
65 - 67°	6

TUNING ANTENNA FOR BEST PICTURE

STEP 8: Your receiver should indicate it is receiving a signal. To tune your antenna for the best picture **slowly** move the antenna left, then right until you have found the position that gives the highest signal strength. **It is important to turn the antenna slowly; since the signal is digital the receiver takes a few seconds to lock on.**

STEP 9: Tighten the clamp knob. This prevents the antenna from moving and losing the signal.

STEP 10: **Slowly** raise then lower the antenna until you have peaked the signal. **You are now ready to watch satellite TV!**

LOWERING ANTENNA TO TRAVEL POSITION

STEP 1: Loosen clamp knob.

STEP 2: Rotate antenna until pointer on directional handle aligns with travel position indicator on ceiling plate. "TRAVEL POSITION" should be visible.

STEP 3: Turn elevating crank (counter clockwise) in "DOWN" direction about 13 turns or until resistance is met.

STEP 4: Tighten clamp knob. Antenna is now locked in travel position.

CAUTION: UNDER NO CONDITIONS SHOULD ANTENNA BE LOWERED UNLESS DIRECTIONAL HANDLE INDICATOR IS IN THE TRAVEL POSITION.

DO'S

1. *Do* check parking location for obstructions before raising antenna.
2. *Do* carefully raise, lower and rotate - if difficult, check for cause.
3. *Do* rotate slowly when searching for the satellite(s) and check fine tuning on TV set to make sure it is properly adjusted.
4. *Do* lower antenna before moving vehicle.

DON'T'S

1. *Don't* force elevating crank up or down. Check for cause of trouble.
2. *Don't* rotate directional handle hard against stops.
3. *Don't* travel with lift in up position.
4. *Don't* leave lift part way up or down.
5. *Don't* apply paint over top of base plate or anywhere on lift.
6. *Don't* apply sealing compound on gear housing.

MAINTENANCE

MOUNT LUBRICATION

To lubricate the mount, apply a liberal amount of silicone spray lubricant to the elevating gear and between the gear housing and baseplate. Run the antenna up/down and rotate the antenna to distribute the lubricant. See Figure 6.

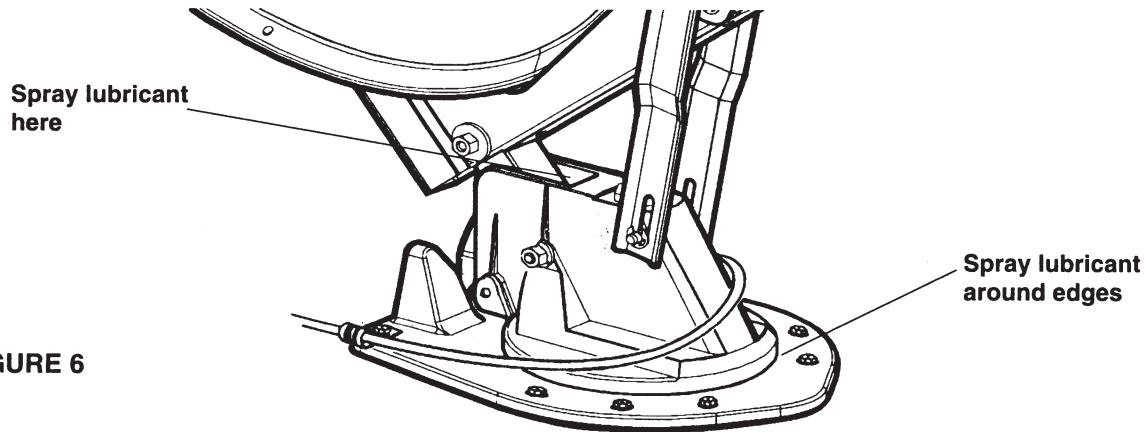

FIGURE 6

LUBRICATING RUBBER QUAD RING

Lubricate rubber quad ring on elevating shaft which is below worm gear with silicone spray lubricant at least **twice yearly** (Figure 7). This will keep quad ring from becoming brittle which could result in leaks down elevating shaft.

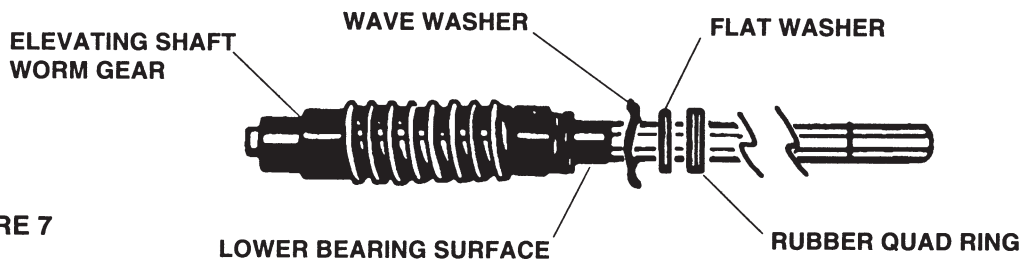

FIGURE 7

ELEVATING SHAFT & WORM GEAR ASSEMBLY REPLACEMENT PROCEDURE

NOTE: It is not necessary to remove rotating gear housing from base plate or remove antenna from roof to replace the shaft & worm gear assembly.

STEP 1: Lower antenna to travel position. Loosen set screw on elevating crank, remove crank, spring, directional handle. Parts list page 10.

STEP 2: Remove E-clip from pin holding elevating tube in rotating gear housing and remove pin. Parts list page.

STEP 3: Remove plastic plug from top of rotating gear housing, disengage elevating gear, remove elevating shaft assembly. Parts list page 10.

STEP 4: Lubricate worm gear assembly on new elevating shaft assembly with spray silicone lubricant. **Make sure wave washer, flat washer and quad ring are on lower bearing** (Figure 7) and insert assembly in housing.

STEP 5: Reinstall plastic plug in top of housing. Gears will mesh automatically once elevating crank is turned.

STEP 6: Replace directional handle, spring and elevating crank. Make sure set screw contacts flat surface on shaft before tightening.

TROUBLE SHOOTING

NO/SNOWY PICTURE

1. Check that you have a clear line of sight to the satellite (no trees, buildings, etc.).
2. Check that you have the TV set tuned for the correct channel 4 or 3.
3. Double check that you have entered the correct zip code into the receiver. If zip code is wrong this can cause you to look in the wrong direction/elevation for the satellite.
4. Check connections at receiver, TV, and antenna.
5. Check TV. Does it receive pictures from off-air TV stations/VCR?
6. Retune system for best picture per procedure on page 7.
7. Inspect antenna. Make sure that it has not been damaged. If antenna is even slightly bent the receiver may not receive any signal.
8. Contact Dealer or Winegard Service Department.

ANTENNA DOES NOT/HARD TO ROTATE

1. Inspect antenna on roof. Make sure that mount has not been damaged.
2. Check for caulking between gear housing and baseplate.
3. Lubricate mount per procedure on page 8.
4. Contact Dealer or Winegard Service Department.

ANTENNA DOES NOT/HARD TO RAISE

1. Inspect antenna on roof. Make sure that mount has not been damaged.
2. Check for caulking on elevating shaft.
3. Lubricate elevating shaft per procedure on page 8.
4. Contact Dealer or Winegard Service Department.

WARRANTY REPAIR WORK

Before you have warranty work done on the system, make sure the company/person performing the work has been approved by Winegard Company. If not, contact Winegard Service Department (1-800-788-4417) before proceeding. The Winegard warranty covers only the mount, antenna and LNBF. **For receiver warranty refer to the manufacturers warranty.**

ORDERING REPAIR PARTS

Repair parts are available at many RV dealers and/or service centers throughout the country. Or you can call the Winegard Company 1-319-754-0600 (credit cards accepted).

PARTS LISTS

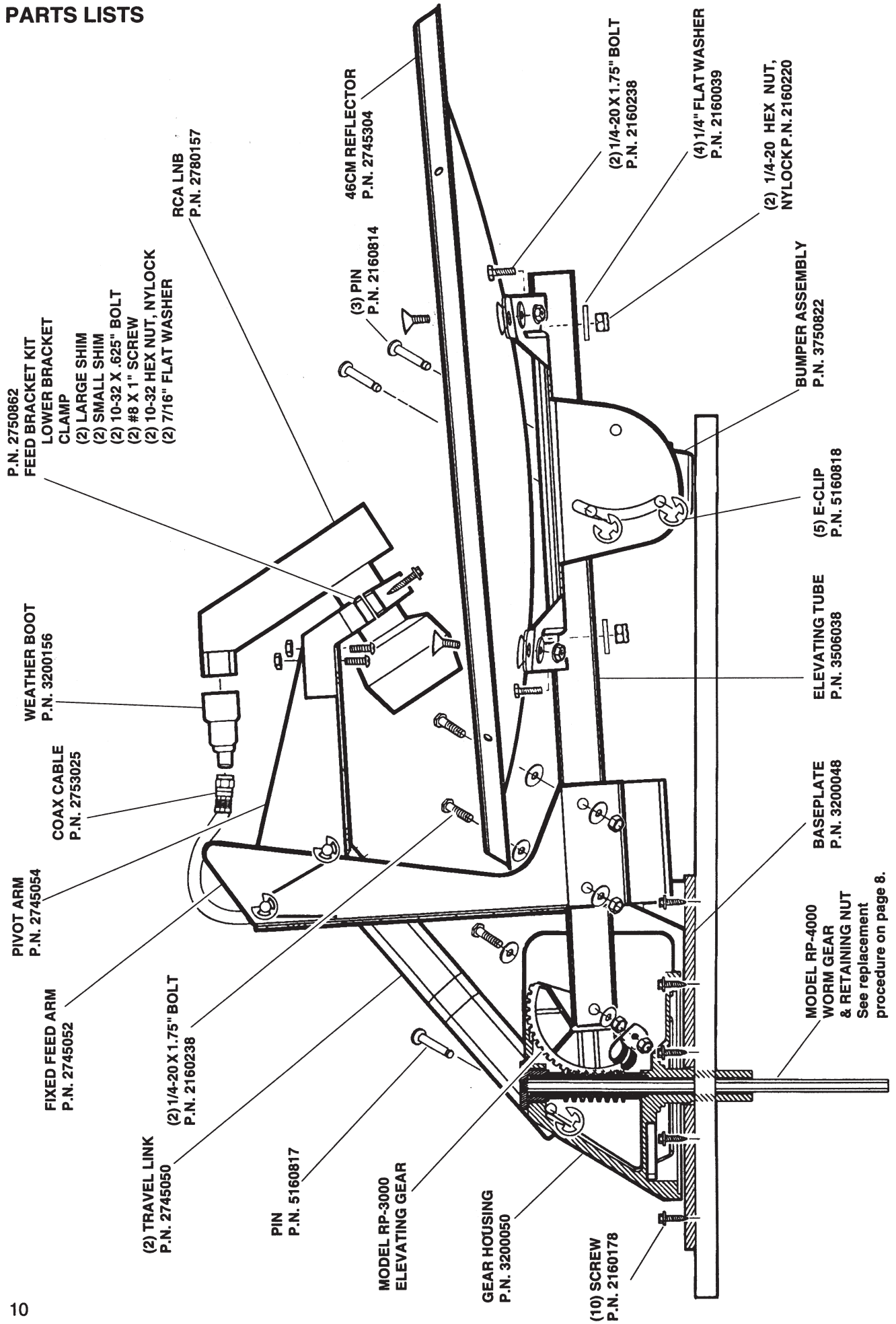

PARTS LISTS

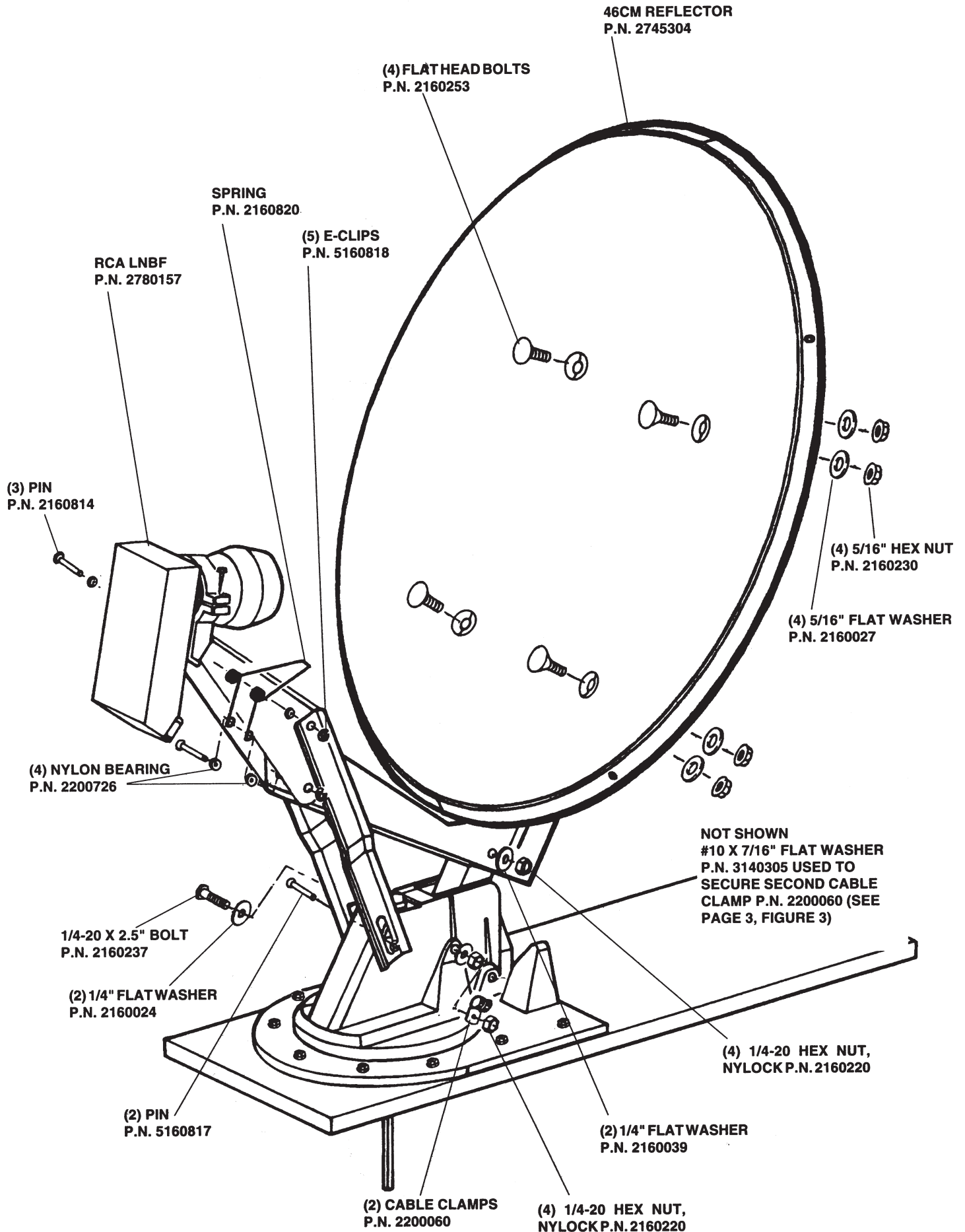

PARTS LISTS

MODEL RP-6300
 CEILING PLATE
 (4) #10 PHILLIPS FLAT
 HEAD SCREWS
 DIRECTIONAL HANDLE
 DECAL (not shown)
 POLYETHYLENE SHIM

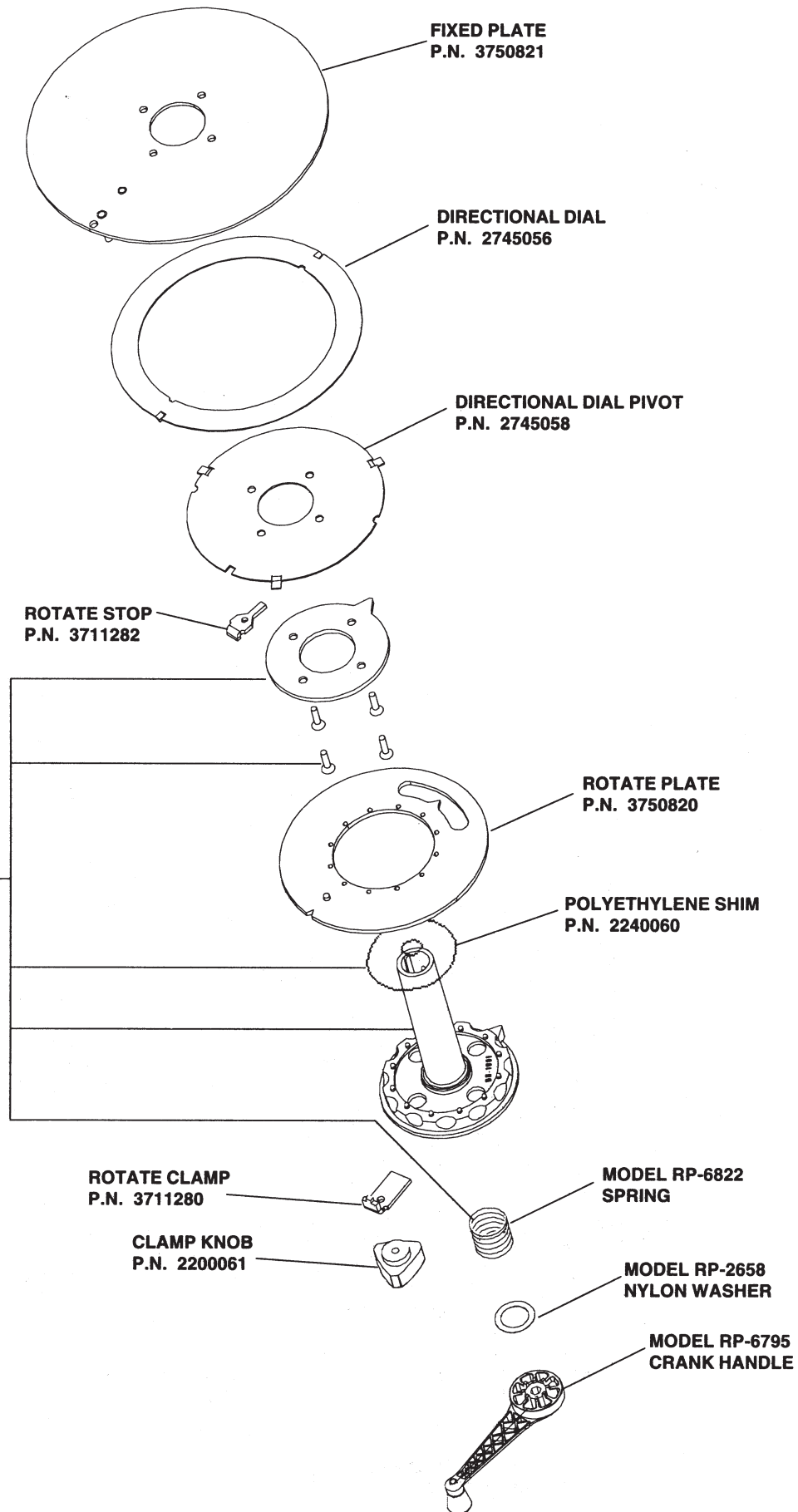

SPECIFICATIONS

ANTENNA & MOUNT

Height when raised	27.25" max.
Height in the travel position	12.0" max.
Operating radius	17" (34" diameter circle)
Roof space required	19.5" x 31"
LNB	RCA
Weight	13 lbs. max.
Color	Light grey
Antenna height	20.9"
Antenna width	19.5"
F/D	0.59
Offset angle	24°
Frequency range	10.95 - 12.75 GHz
Gain:	
11.2 GHz	33.22 dBi
12.1 GHz	33.89 dBi
12.6 GHz	34.23 dBi
Aperture efficiency	73%
Cross polarization (on axis)	-21 dB
*Beamwidth at -3 dB	3.5°
*Beamwidth at -10 dB	7.0°
Wind loading	Up to hurricane force

SYSTEM

Shipping weight:	
RD-4600 (no receiver)	16 lbs.
RD-1046 (w/RCA DSS® receiver)	29 lbs.
Power	Refer to receiver manual

DSS® is a registered trademark of DIRECTV, Inc., a unit of GM Hughes Electronics.

MODEL RP-4002 THICK ROOF KIT AVAILABLE

Winegard Company makes available Model RP-4002 which includes 2762816 directional handle and 2764155 elevating shaft worm gear assembly. The RP-4002 is designed for roofs 4 to 6 inches thick. Contact Winegard Company if roof thickness measures more than 6 inches. Refer to the table below for the correct directional handle and elevating shaft measurements.

ROOF THICKNESS	CUT DIRECTIONAL HANDLE TO LENGTH	CUT ELEVATING SHAFT TO LENGTH	W/RW-1000
6"	6 9/16"	7 1/2"	8"
5 3/4"	6 5/16"	7 1/4"	7 3/4"
5 1/2"	6 1/16"	7"	7 1/2"
5 1/4"	5 13/16"	6 3/4"	7 1/4"
5"	5 9/16"	6 1/2"	7"
4 3/4"	5 5/16"	*NO CHANGE	6 3/4"
4 1/2"	5 1/16"	*6"	6 1/2"
4 1/4"	4 13/16"	*5 3/4"	*NO CHANGE

* Use existing elevating shaft.

ANTENNA/LIFT ONE YEAR LIMITED WARRANTY

Winegard Company warrants this product (excluding receiver) against any defects in materials or workmanship within one (1) year from date of purchase. No warranty claim will be honored unless at the time the claim is made, you present proof of purchase to an authorized Winegard dealer (if unknown, please contact Winegard Company, 3000 Kirkwood Street, Burlington, Iowa 52601-2000, telephone 319-754-0600).

Winegard Company (at its option) will either repair or replace the defective product at no charge to you. This warranty covers parts, but does not cover any costs incurred in removal, shipping or reinstallation of the product. The warranty does not extend to products which have been subjected to misuse, improper installation, or to damage caused by wind, lightning, ice or other occurrences over which the manufacturer has no control.

The One Year Warranty is provided on the condition that the equipment is properly delivered with all handling and freight charges prepaid to your Winegard dealer for repair or return to our factory at the above address. Winegard dealers will arrange for the replacement or repair and return to you, without charge, the product which failed due to defective material or workmanship.

WINEGARD COMPANY WILL NOT ASSUME ANY LIABILITIES FOR ANY OTHER WARRANTIES, EXPRESS OR IMPLIED, MADE BY ANY OTHER PERSON.

ALL OTHER WARRANTIES WHETHER EXPRESS, IMPLIED OR STATUTORY INCLUDING WARRANTIES OF FITNESS FOR A PARTICULAR PURPOSE AND MERCHANTABILITY ARE LIMITED TO THE NINETY DAY PERIOD OF THIS WARRANTY.

The foregoing shall be the sole and exclusive remedy of any person whether in contract, tort or otherwise, and Winegard shall not be liable for incidental or consequential damage or commercial loss, or from any other loss or damage except as set forth above.

Some states do not allow limitations on how long an implied warranty lasts, or the exclusion of limitation of incidental or consequential damages, so the above limitations or exclusions may not apply to you.

This warranty gives you specific legal rights and you may also have other rights which may vary from state to state.

LNBF 90 DAY LIMITED WARRANTY

Winegard Company warrants the LNBF against any defects in materials or workmanship within ninety (90) days from the date of purchase. No warranty claim will be honored unless at the time the claim is made, you present proof of purchase to an authorized Winegard dealer (if unknown, please contact Winegard Company, 3000 Kirkwood Street, Burlington, Iowa 52601-2000, telephone 319-754-0600).

Winegard Company (at its option) will either repair or replace the defective product at no charge to you. This warranty covers parts, but does not cover any costs incurred in removal, shipping or reinstallation of the product. The warranty does not extend to products which have been subjected to misuse, improper installation, or to damage caused by wind, lightning, ice or other occurrences over which the manufacturer has no control.

The Ninety Day Warranty is provided on the condition that the equipment is properly delivered with all handling and freight charges prepaid to your Winegard dealer for repair or return to our factory at the above address. Winegard dealers will arrange for the replacement or repair and return to you, without charge, the product which failed due to defective material or workmanship.

WINEGARD COMPANY WILL NOT ASSUME ANY LIABILITIES FOR ANY OTHER WARRANTIES, EXPRESS OR IMPLIED, MADE BY ANY OTHER PERSON.

ALL OTHER WARRANTIES WHETHER EXPRESS, IMPLIED OR STATUTORY INCLUDING WARRANTIES OF FITNESS FOR A PARTICULAR PURPOSE AND MERCHANTABILITY ARE LIMITED TO THE NINETY DAY PERIOD OF THIS WARRANTY.

The foregoing shall be the sole and exclusive remedy of any person whether in contract, tort or otherwise, and Winegard shall not be liable for incidental or consequential damage or commercial loss, or from any other loss or damage except as set forth above.

Some states do not allow limitations on how long an implied warranty lasts, or the exclusion of limitation of incidental or consequential damages, so the above limitations or exclusions may not apply to you.

This warranty gives you specific legal rights and you may also have other rights which may vary from state to state.

RECEIVER 90 DAY LIMITED WARRANTY

RCA warrants the receiver for 90 days. See receiver manual for specific receiver warranty information.

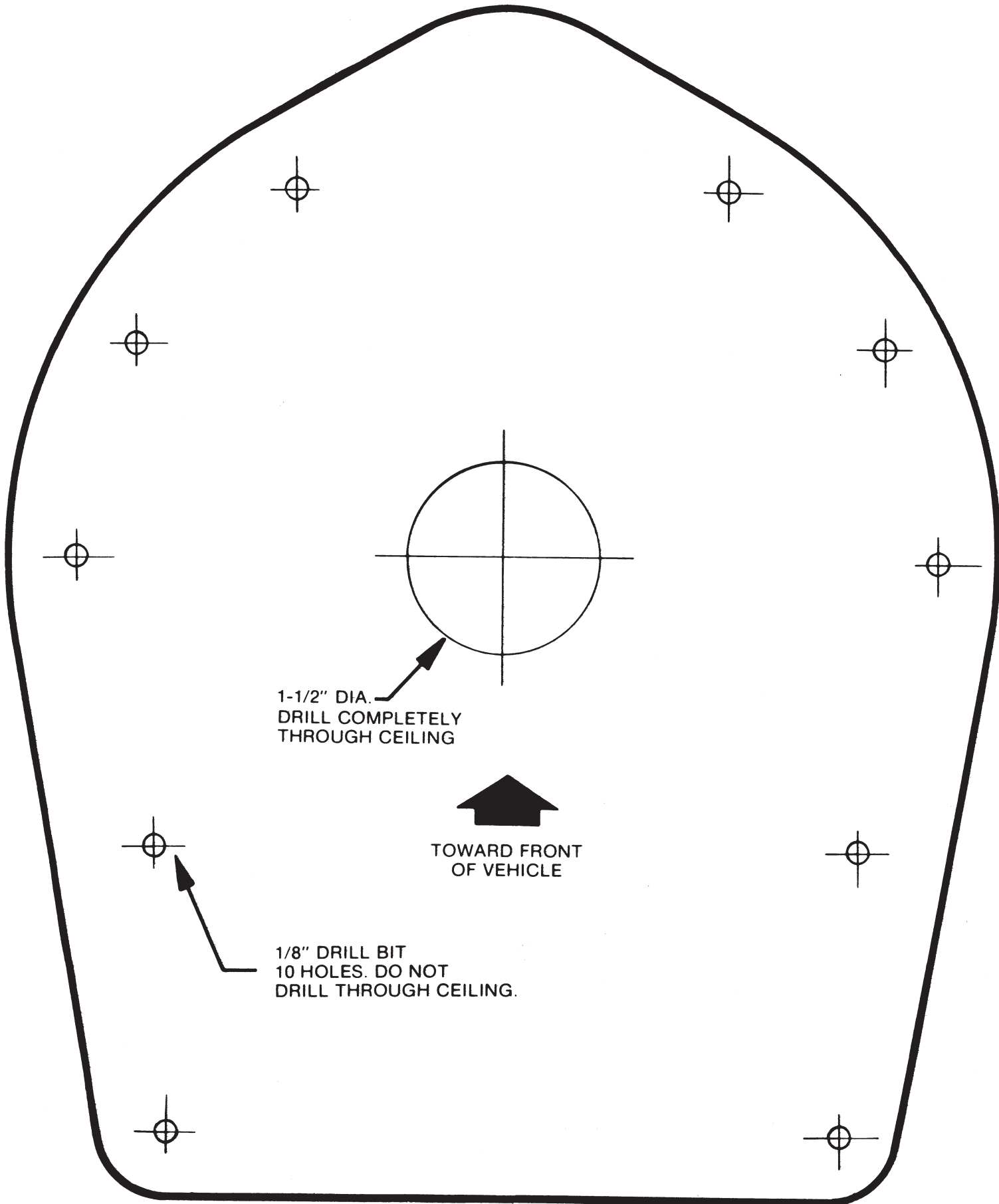

1-1/2" DIA.
DRILL COMPLETELY
THROUGH CEILING

TOWARD FRONT
OF VEHICLE

1/8" DRILL BIT
10 HOLES. DO NOT
DRILL THROUGH CEILING.

