

SERVICE MANUAL

(INTERNATIONAL)

IMPINGER CONVEYOR OVENS

LOW PROFILE 1600 INTERNATIONAL ADVANTAGE



Lincoln Foodservice Products, LLC
1111 North Hadley Road
Fort Wayne, Indiana 46804
United States of America

Phone: (800) 374-3004
U.S. Fax: (888) 790-8193 • Int'l Fax: (260) 436-0735

Technical Service Hot Line
(800) 678-9511

www.lincolnfp.com



SERVICE AND PARTS MANUAL

1600 INTERNATIONAL ADVANTAGE

SEQUENCE OF OPERATIONS	3
SCHEMATIC	5
TROUBLESHOOTING GUIDE	6
REMOVAL, INSTALLATION & ADJUSTMENTS.....	12
GENERAL PARTS	20
ADVANTAGE SERIES.....	20
CONTROL BOX, RIGHT PARTS.....	22
CONTROL BOX, LEFT PARTS.....	24
OVEN BACK PARTS	26
CONVEYOR PARTS	28

SEQUENCE OF OPERATIONS

MODEL 1633-000-EA 230 VAC 50HZ NATURAL GAS
MODEL 1634-000-EA 230 VAC 50HZ L.P. GAS

POWER SUPPLY

Electrical power to be supplied to the oven by a three conductor service.

Brown conductor is hot
Blue conductor is neutral.
Green conductor is ground.

CONTROL BOX AUTO COOL DOWN

When the temperature in either one of the control boxes reaches $120^{\circ}\text{F} \pm 3^{\circ}$ ($49^{\circ}\text{C} \pm 1.7^{\circ}$), the cooling fan thermostats will switch power to the cooling fans. The thermostats will interrupt power to the cooling fans when the temperature falls to $100^{\circ}\text{F} \pm 3^{\circ}$ ($37^{\circ}\text{C} \pm 1.7^{\circ}$)

MAIN FAN CIRCUIT

Line voltage is permanently supplied to a normally open contact of the oven power switch. Line voltage is permanently supplied to the two normally open cooling fan thermostats, a normally open contact of the oven power relay. Closing the oven power switch supplies line voltage to oven power relay, its contacts now close, supplying line voltage to the two main fan motors and the two burner circuits. Closing the oven power switch also supplies line voltage to the control box cooling fans, the temp. display, and the conveyor circuit.

BURNER CIRCUIT

NOTE: This oven utilizes two complete burner/ temperature control systems. The sequence of operations is the same for each system.

Closing the main fan switch supplies line voltage, through the oven power relay, through a three amp. fuse, through the gas pressure switch, through the main fan air pressure switch through the oven cavity hi-limit thermostat, to the ignition control. The combustion motor is energized. The normally open combustion air switch closes upon sensing air pressure. After a pre-purge period of between 30 and 60 seconds, the ignition transformer and the main gas valve are energized. Ignition should now occur.

TEMPERATURE CONTROL

Closing the oven power switch supplies line voltage, through the oven power relay, through a three amp. fuse, through the gas pressure switch, through the main fan air pressure switch through the oven cavity hi-limit thermostat, to the temperature control board. The 1.0K temperature pot. is adjusted to desired temperature. The thermocouple will provide varying millivolts to the temperature control. The temperature control supplies line voltage to the solenoid valve at intermittent intervals to maintain desired temperature.

CONVEYOR DRIVE

Closing the oven power switch supplies line voltage, through the oven power relay, through the electromagnetic filter to the conveyor control. AC volts are converted to DC volts and are supplied to the conveyor motor at terminals A+ and A-.

Adjustments of the speed control potentiometer will change resistance at terminals P1 and P2 varying the DC voltage to the motor. The speed of the conveyor motor will increase or decrease as the DC voltage from the board increases or decreases respectively.

NOTE: The conveyor control uses a sensor and magnet, mounted on the conveyor motor that senses motor speed. Any change in motor load (\pm RPM) is detected by the sensor and the voltage to the motor is adjusted accordingly.

TEMPERATURE DISPLAY

Closing the power switch supplies line voltage to the primary of the temperature display transformer. The secondary of this transformer supplies 12 VAC to the temperature display. The thermocouple supplies DC millivolts to the temperature display. The display converts this millivolt reading to a temperature reading.

SCHEMATIC MODELS 1633-000-EA AND 1634-000-EA

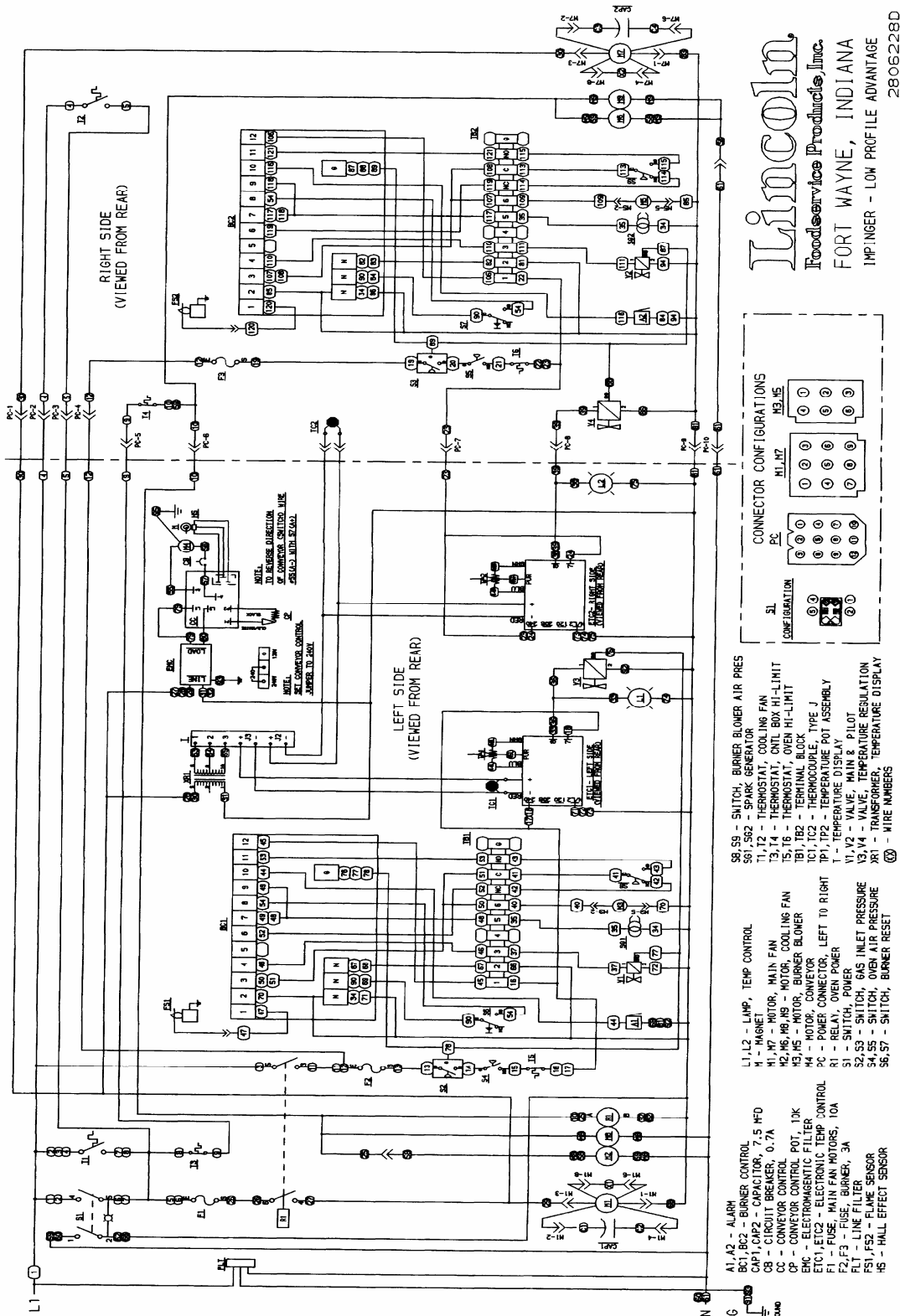

TROUBLESHOOTING GUIDE

MODEL 1633-000 EA NATURAL GAS 230 VAC 50 HZ 1 PHASE
 MODEL 1634-000-EA L.P. GAS 230 VAC 50 HZ 1 PHASE

NOTE: When checking components on left side of unit, be sure to check for proper connections in power connector, (marked P. C. on schematic diagram) located inside motor cover.

SYMPTOM	POSSIBLE CAUSE	EVALUATION
Oven fan will not run	Incoming power supply	Check breakers/ reset if required call Power company if needed
	Oven fan switch	Check continuity between switch terminals.
	Thermostat, hi-limit	Terminals are normally closed, if open, reset thermostat and test oven for proper operation. If it will not reset, replace thermostat.
	Fan fuse Fuse holder Oven fan relay	Check, replace if necessary. Check for power to coil of oven fan relay. If no voltage is present, trace wiring back to hi-limit thermostat. Check for supply voltage at terminal #6 of the relay. If no voltage is present, trace wiring back to fuse holder. If voltage is present, at the relay coil, check to insure the contacts are closing.
No control box cooling	Capacitor(s)	Check for opens, shorts, or grounds.
	Motor (s)	Check for opens, shorts, or grounds.
	Fan switch	(SEE OVEN
	Hi-limit	FAN WILL
	Oven fan relay	NOT RUN.)
No automatic control box cooling	Incoming power supply	Supply voltage should now be at these motors. If voltage is present, check motor for open, shorts, or grounds. WITH POWER OFF: check for locked rotor.
	Cooling fan thermostats	Check circuit breakers, reset if needed. Call power company if needed. Thermostat closes at 120°F and opens at 100°F. With the cooling fan thermostat preheated, check for continuity. If switch is open, replace.
	Cooling fan(s)	Supply voltage should now be at these motors. If voltage is present, check motor for opens, shorts or grounds. WITH POWER OFF: Check for locked rotor.
Oven will not heat	Gas supply	Check for adequate gas supply to oven.
	Manual gas shut off valve	Check to see that the manual gas shut off valve is open.
	Fan switch Main oven fan	Check to see that the fan switch is on. Check if main oven fan is operating. if not, refer to "oven fan will not run".
NOTE: These ovens utilize 2 complete Burner/Temperature control systems. Each system will Follow the same troubleshooting sequence.		
	Fuse, burner 3A.	Check, replace if necessary.

Fuse holder	Check, replace if necessary.
Gas pressure switch (internal to gas valve)	Check for supply voltage to neutral on both sides of switch. If voltage is present on one side of switch only, check the following. Check for proper gas pressure supply to gas valve. (Marked on oven spec. plate.) Check for proper adjustment of gas pressure switch. should be set at 10 Nat., 27 for L.P. or 4.5 for town gas. Check gas filter in gas valve for blockage or damage. (See Adjustment section for location.) If the above checks OK, but switch is still not closed replace gas valve.
Oven air pressure switch	Check for supply voltage on both sides of switch. If voltage is present on one side only, check for air tube blockage. Adjust air pressure switch. If the above fails, replace air pressure switch.
Hi-limit thermostat	Terminals are normally closed. If open, reset and test oven for proper operation. If thermostat will not hold for maximum oven temperature, and oven is not exceeding maximum temperature dial setting, check for proper location of capillary bulb in its spring holder. If above checks OK, replace hi-limit.
Ignition control	Check for supply voltage to ignition control at terminal #1 and neutral. If voltage is not present, trace wiring back to hi-limit thermostat. Check for supply voltage at terminal #6 to neutral. If no voltage is present, wait 30 seconds and check reset button. If above fails, replace ignition control.
Burner reset switch	Switch is normally open. Check to see that the switch closes when reset button is pushed. Replace as needed.
Burner blower motor	Check for supply voltage to burner blower motor. WITH POWER OFF: Turn blower wheel to check for locked rotor. If supply voltage is present and motor does not run, replace motor.
Burner blower motor Air pressure switch	Check for supply voltage switching to terminal N. O. as the air pressure switch closes. Check for air tube blockage or misalignment, adjust air pressure switch. If the above fails, replace air pressure switch.
Spark generator	After a pre-purge time of 30 to 60 seconds after blower motor starts, check for supply voltage to spark generator. If voltage is not present, Check reset button located on rear of control box. If voltage is still not present, replace ignition control. If voltage is present, visually check for spark at igniter head.
Igniter/sensor assembly	Check for visible damage to igniter/sensor assembly. If there is no visible damage to the components, and no spark,

	Gas valve	<p>replace the spark generator. If there is visible damage to the igniter/sensor assembly, replace. Also check for frayed or damaged wires in burner tube.</p> <p>Check for supply voltage to gas valve. If there is no voltage present, check reset button, check all connections for tightness. If there still is no voltage at gas valve, replace ignition control. If there is voltage present, check for gas pressure at gas pressure tap located in gas piping at burner manifold. If there is no gas pressure, replace gas valve.</p>
Flame will not stay on	Flame sensor	<p>To check for flame sensor operation, connect a digital multimeter (capable of measuring D.C. micro amps) in series with the flame sensor wire and ignition control. Sensor current is 3 micro amps D.C. minimum.</p> <p>NOTE: The D.C. micro amp test must be conducted with the oven in low flame (bypass) operation. Turn the temperature control to its lowest setting. If these readings are not achieved, replace igniter/sensor assy. Also, check for any type of damage to flame sensor wire and connections.</p>
	Ignition control	<p>If there is sufficient flame sensor current, but the burner will not remain ignited, check the reset button on ignition control.</p> <p>NOTE: Check for proper polarity of the power supply. If all of the above are OK, replace ignition control.</p>
Pilot lamp is on, But no main flame	Temperature control	<p>Check for supply voltage across terminals L2 and 240 on temperature control board. If no voltage is present, check wiring back to hi-limit thermostat. Turn the temperature adjustment knob to the maximum temperature position and check for supply voltage at the load terminal #7 and #8. If voltage is present and unit is not heating, refer to "temperature regulation valve" for next check. If voltage is not present, proceed.</p>
	Thermocouple probe	<p>With power on and thermocouple leads attached to board, measure the millivolt out put of the thermocouple. Refer to the thermocouple chart in section D for proper readings.</p>
	Temperature control Potentiometer	<p>WITH POWER OFF: Remove the potentiometer leads from the temperature control board. Place ohm meter test leads on the blue and green pot leads. Reading should be 1 K ohms. Place meter leads across the blue and purple pot leads and rotate knob from high to low. Repeat on green and purple leads. Check for even rise and fall of ohms reading to insure that there are no open or dead spots in the potentiometer. Check each lead to ground for shorts. Replace potentiometer</p>

	Temperature regulation valve	as needed. If supply voltage is present on the temperature control board at the load terminals #7 and #8, check for voltage at temperature regulation valve. If voltage is present, listen for valve to open and close. Also, check for opens or shorts in the coil. Replace if required.
Intermittent heating	Thermal overload of main fan and burner blower motors	The main fan motors and the burner blower motors are equipped with internal thermal protection and will cease to operate if overheating occurs. As the motors overheat and then cool, this will cause the units to cycle on and off intermittently. This may be caused by improper ventilation or lack of preventive maintenance. Also, most of the problems listed under "Oven will not heat" can cause intermittent failure.
Conveyor will not run	Power supply	Check for supply voltage at terminals L1 and L2. If voltage is not present, check breakers.
	Fan switch	See procedure for checking on page 6.
	Fuse, 10 Amp.	Check and/or replace.
	Fuse holder	Check and/or replace.
	Filter E.M.I.	Check for supply voltage input to filter. If there is no voltage, trace wiring back to relay. If there is input voltage, check for output voltage. If there is input voltage but no output voltage, replace filter.
	Speed adjustment potentiometer	This is a 0 to 10K ohm, 1 turn potentiometer. With power off, remove the black and white pot leads from the conveyor control board at terminals P1 and P2. Place the meter leads on black lead (P2) and the white lead (P1). Rotating the pot. slowly, from low to high, the meter reading should show an even transition from 0 to 10K ohms \pm 5%. There should be no dead or open spots through the one turn of the pot. Check both leads to ground. There should be no continuity to ground. If any of the above fail, replace the potentiometer.
	D.C. motor control board	Check for supply voltage input to the control board at terminals L1 and L2 If not present, check wiring back to the filter. If supply voltage is present, check both fuses on the control board (8 Amp. line and 1Amp. armature). Check the D.C. voltage output at terminals A+ and A-. If A.C. voltage is at terminals L1 and L2, and no D.C. voltage is present at A+ and A-, replace control board. If A.C. voltage is present and D.C. voltage is present but the motor will not run, check gear motor as follows:
	Conveyor	If D.C. voltage is present at A+ and A-

	gear motor	and the motor does not run, first check the mini breaker and then the conveyor. Refer to the next possible cause. Check the leads to the motor for evidence of any shorts or opens, and each lead to ground. Check motor brushes. From the top of the motor, rotate motor shaft to determine if there is a locked rotor or a locked gearbox (use care so magnet and Hall Effect sensor board are not damaged). Replace motor as needed.
	Conveyor	Check for any mechanical misalignment. Also, check for worn bearings. A conveyor belt that is over tightened will cause excessive bearing wear and sometimes, irregular speed.
Conveyor speed varying or intermittent	Power supply	Check power supply at the D.C. control board for supply voltage at board terminals L1 and L2.
	Motor control board	Place the test meter probes on terminals A+ and A-. (with speed potentiometer set to maximum speed – approximately 2 min.). The meter reading should be approximately 100VDC(±3%), if voltage is not steady within limits, then the board is usually bad. Always check the speed potentiometer, be sure it is OK before changing a control board. This test is not always 100% accurate as this test is not performed at operating speeds, However, this test is the best method currently available.
	D.C. Gearmotor	If the D.C. control board is steady, then the problem may be the motor or gearbox. Check the brushes in the motor for excessive arching or unusual wear. Check the motor and gearbox from instructions located on page 9 under “possible cause” listing “conveyor gear motor”
	Magnet	Check to insure that the magnet (cemented to shaft of conveyor drive motor) has not been damaged, or come loose from the motor shaft. Replace as needed.
	Hall Effect Sensor	Check for any physical damage to hall effect sensor (mounted on conveyor drive motor). Check all wiring and connections for tightness and proper location. Replace as needed. Connect new hall effect to system and check for steady operation.
Temperature display inoperative	Display transformer	Measure the transformer primary for supply voltage input. If voltage is not present, trace wiring back to the fan relay. If voltage is present, measure the secondary output of the transformer. Voltage across terminals 1-3 should be 12-15VAC. Terminals 1-2 and 2-3 should be ½ the voltage reading from terminals 1-3. If the above

	Temperature display	secondary readings are not achieved, replace transformer. If proper voltage is present at terminals 1,2, and 3 on temperature display, but but the display is not lighted, recheck all connections for tightness. If temperature display is still not operating, replace the temperature display.
Temperature display Inaccurate, erratic Or inoperative	Thermocouple	Connect the thermocouple of a pyrometer to the thermocouple on the temperature control board. (be sure to maintain proper polarity of thermocouple leads—see adjustment section for proper procedure.) The pyrometer will indicate oven temperature display. Measure D.C. millivolts of thermocouple at the temperature display. See thermocouple chart in section D for proper readings. Replace thermocouple if proper readings are not achieved. If readings are correct on the thermocouple, replace temperature display.

REMOVAL, INSTALLATION & ADJUSTMENTS

MODEL SERIES 1633-000-EA, 1634-000-EA

CAUTION !

BEFORE REMOVING OR INSTALLING ANY COMPONENT IN THE IMPINGER OVEN BE SURE TO DISCONNECT ELECTRICAL POWER AND GAS SUPPLY.

IGNITION CONTROL – REPLACEMENT

- A. Remove appropriate control box cover.
- B. Remove front portion of relay by releasing tabs on side pulling straight out (rocking motion).
- C. Remove wires from plug-in terminal strip, note wire numbers and location.
- D. Remove two screws from mounting bracket and remove.
- E. Reassemble in reverse order. Check system operation.

BURNER BLOWER MOTOR – REPLACEMENT

- A. Remove appropriate control box cover.
- B. Unplug motor connector.
- C. Remove three screws from blower tube at burner housing.
- D. Remove air shutter assy. From old motor for installation on new motor assy.
- E. Reassemble in reverse order and check system operation

NOTE : CHECK AIR SHUTTER ADJUSTMENT – should be set at ½ open.

BURNER INDICATOR LIGHT – REPLACEMENT

- A. Remove control box cover.
- B. Remove two wires from light housing.
- C. Slide light housing sideways to remove.
- D. Reassemble in reverse order and check system operation.

AIR PRESSURE SWITCH – REPLACEMENT

- A. Remove control panel top.
- B. Disconnect wires from switch making note of wire number and location for reinstallation.
- C. Remove air tube from switch assembly.
- D. Remove switch from wire hanger.
- E. Install new switch in reverse, make sure air tube is not blocked or misaligned.

To adjust air pressure switch, remove cover from the switch to expose adjusting screw. To increase sensitivity, turn screw counter- clockwise ; to decrease sensitivity, turn screw clockwise. Check for proper line voltage switching from N.C. to N.O. as the air pressure switch closes.

CONVEYOR CONTROL POTENTIOMETER (10 K OHM) – REPLACEMENT

- A. Remove control box cover.
- B. Loosen two allen screws and remove knob by sliding off shaft.
- C. Remove nut from potentiometer shaft and push out.
- D. Unplug wire connector from conveyor control board.
- E. Reassemble in reverse order and check system operation.
- F. Recalibrate conveyor control board.

CONVEYOR CONTROL BOARD – REPLACEMENT

- A. Shut off power at main breaker.
- B. Remove control panel top and front cover.
- C. Disconnect wiring (push on connectors) from control board, note proper location of connectors for reinstallation and exchange boards on the mounting bracket before reinstallation.
- D. Reassemble in reverse order and check system operation.

CONVEYOR CONTROL BOARD – CALIBRATION

- A. Connect digital volt meter to the hall effect sensor. Black meter lead connected to black hall effect sensor lead, red meter lead to white hall affect sensor lead.
- B. Turn conveyor control knob fully counter clockwise. Loosen knob and align with calibration line and tighten knob.
- C. Set knob to 2 minute setting. Adjust “max” pot. On conveyor control to 219 Hz.
- D. Set control knob to 20 minute setting, and adjust “min” pot. On conveyor control to 21.9 Hz. Recheck at 2 minute and 20 minutes until proper readings are achieved. seal pots with glyptol or nail polish.

CIRCUIT BREAKER

- A. Shut off power at main breaker.
 - B. Remove control top and front panel.
 - C. Disconnect 2 wires from circuit breaker.
 - D. Remove knurled mounting nut and push out.
 - E. Reassemble in reverse order.
- NOTE: Be sure to reset breaker before operation.

CONVEYOR DRIVE MOTOR – REPLACEMENT

- A. Shut off power at main breaker.
- B. Remove conveyor.
- C. Remove control panel top and front cover.
- D. Disconnect wiring from motor and mark for reassembly.
- E. Remove sprocket from motor shaft.
- F. Remove 4 screws and remove conveyor motor and mounting bracket.
- G. Remove mounting bracket from conveyor motor assembly.
- H. Reassemble in reverse order.

REVERSING CONVEYOR DIRECTION

- A. Shut off power at main breaker.
- B. Remove control panel top .
- C. Reverse wires fastened to terminals A+ and A- on conveyor control board.(See schematic diagram for wire numbers)
- D. Reassemble in reverse order.

HALL EFFECT SENSOR – REPLACEMENT

- A. Shut off power at main breaker.
- B. Remove control panel top and front cover.
- C. Remove conveyor motor assembly.
- D. Remove wire connector from hall affect sensor board.
- E. Remove 2 screws from conveyor drive motor.
- F. Remove sensor board from mounting bracket.
- G. Reassemble in reverse order.

FUSEHOLDER – REPLACEMENT

- A. Remove appropriate control box cover.
- B. Remove 2 wires, note wire number and location.
- C. Remove lock nut on back side of fuse holder and push out.
- D. Reinstall in reverse order and check system operation.

GAS VALVE – REPLACEMENT AND ADJUSTMENT

- A. Remove appropriate control box cover .
- B. Disconnect the gas piping from the back of the unit.
- C. Remove the 4 screws from the incoming nipple mounting bracket.
- D. Remove incoming nipple.
- E. Disconnect 2 plugs (1) 3prong and (1) 4 prong – note location.

- F. Disconnect pipe union just above gas valve and remove assembly.
- G. Reassemble in reverse order (check all pipe fittings for leaks). After assembled check for proper adjustment of gas pressure switch, 10 on dial for natural gas, 27 for L.P. gas, and 4.5 for town gas.
- H. Check and adjust manifold pressure. Remove pressure tap located in gas piping above the gas valve prior to the burner orifice and install manometer. Adjustment screw is located on the front of the valve, remove plastic cap and adjust as needed : 3.5" W.C. for natural gas, 10" W.C. for L.P. and 2.0" W.C. for town gas.
- I. Check gas filter by removing cover plate (located on either side of valve) . Remove 4 screws and slide filter out of valve housing and inspect. Reassemble in reverse order and check for leaks around cover.

BURNER ALARM - REPLACEMENT

- A. Remove appropriate control box cover.
- B. Remove 2 wires from alarm , note wire numbers and location.
- C. Remove retainer cover from alarm and remove assembly from control box.
- D. Reassemble in reverse order and check system operation.

SPARK GENERATOR – REPLACEMENT

- A. Remove appropriate control box cover.
- B. Remove 2 wires for spark generator.
- C. Unplug connector on bottom of spark generator.
- D. Remove 2 mounting screws and remove generator assembly.
- E. Reassemble in reverse order and check system operation.

IGNITER SENSOR – REPLACEMENT

- A. Remove appropriate control box cover.
- B. Remove gas valve assembly (see gas valve)
- C. Remove screws from burner tube and pull burner assembly out.
- D. Remove wire connectors from igniter sensor assembly.
- E. Remove screws from mounting bracket and remove assembly.
- F. Reassemble in reverse order and check system operation.

NOTE: After installation, check all pipe fittings for leaks.

SWITCH, BURNER RESET – REPLACEMENT

- A. Remove appropriate control box cover.
- B. Disconnect wires from ignition control (see ignition control). Note wire number and location for reassembly.
- C. Pull off black operating knob and remove hex mounting nut.
- D. Reassemble in reverse order.

TEMPERATURE REGULATING VALVE – REPLACEMENT

- A. Remove appropriate control box cover.
- B. Remove bypass tube assembly.
- C. Remove 4 nuts from burner orifice bracket.
- D. Disconnect pipe union.
- E. Disconnect 2 wires from valve and remove assembly.
- F. Remove gas piping from old valve and install on new valve.
- G. Reassemble in reverse order and check system operation. NOTE: Check all gas line fittings for leaks and insure valve gas flow is in proper direction.

MAIN ORIFICE – REPLACEMENT

- A. Remove appropriate control box cover.
- B. Remove bypass tube assembly.
- C. Remove 4 nuts from burner orifice bracket.
- D. Disconnect pipe union.

- E. Remove assembly and replace main orifice.
 - F. Reassemble in reverse order and check system operation.
- NOTE: Check all gas line fittings for leaks.

TEMPERATURE CONTROL POTENTIOMETER – REPLACEMENT

- A. Remove control box cover.
- B. Loosen screw and slide knob off potentiometer shaft.
- C. Remove lock nut and push out.
- D. Remove 3 wires from electronic temperature control, note wire color and location for reinstallation.
- E. Reassemble in reverse order and check system operation.

THERMOSTAT, HIGH LIMIT, OVEN CAVITY – REPLACEMENT

- A. Remove appropriate control box cover. Remove motor cover and remove oven back to access high limit thermostat.
- B. Remove wires from thermostat, note wire numbers for reinstallation.
- C. Remove mounting nut from high limit thermostat and remove high limit from oven.
- D. Reassemble in reverse order. Check system operation.

ON-OFF SWITCH – REPLACEMENT

- A. Remove control box cover.
 - B. Depress spring clips on side of switch and push out.
 - C. Remove wires from back of switch, note wire number and location.
 - D. Reassemble in reverse order and check system operation.
- NOTE: Make sure switch housing is fully seated in control box housing.

DUAL TEMPERATURE DISPLAY – REPLACEMENT

- A. Shut off power at main breaker.
- B. Remove control panel top and front cover.
- C. Remove all wires from temperature display and mark wires for reassembly.
- D. Pry temperature display to remove from mounting tabs (this is a pressure fit)
- E. Reassemble in reverse order.

CALIBRATE TEMPERATURE

- A. (see page 16 for connection of temperature sensor) Set temp. control to 500° F . Allow temperature to stabilize.
- B. “ Fine tune “ temperature setting to achieve measured temperature swings from 497°F to 503°F. When actual temperature falls between 497°F and 503°F, the display must show 500°F.
- C. Adjust temp. adj. Pot. on temp display to achieve a display reading of 500°F.

TRANSFORMER, TEMPERATURE DISPLAY – REPLACEMENT

- A. Remove control box cover and front panel.
- B. Remove 5 wires (2 primary side, 3 secondary side), note color and location of wires for reinstallation.
- C. Remove 2 screws from transformer base and replace assembly.
- D. Reassemble in reverse order and check system operation.

CAPACITOR, MAIN FAN MOTOR – REPLACEMENT

- A. Remove appropriate control box cover.
- B. Remove 2 wires from capacitor, note wire number and location.
- C. **WARNING:** Capacitor has a stored charge, discharge before handling or testing.
- D. Cut 2 tyraps securing capacitor to base and replace.
- E. Reinstall in reverse order and check system operation.

RELAY – REPLACEMENT

- A. Remove control box cover.
- B. Remove wires from relay, note wire numbers and location for reinstallation.
- C. Remove 2 screws from relay base and replace relay.
- D. Reassemble in reverse order making sure wire connections are properly seated.
- E. Check system operation.

THERMOSTAT, COOLING FAN – REPLACEMENT

- A. Remove appropriate control box cover.
- B. Remove 2 wires from thermostat, note wire number and location.
- C. Remove 2 mounting screws and replace thermostat.
- D. Reassemble in reverse order and check system operation.

ELECTRONIC TEMPERATURE CONTROL – REPLACEMENT

- A. Remove control box cover and front panel.
- B. Identify correct control and remove wires from control. Note wire number
- C. and location for reinstallation.
- D. Remove temperature control from mounting tabs.
- E. Reassemble in reverse order and check system operation.

TEMPERATURE SETTING FOR NEW TEMPERATURE CONTROL BOARD

PROCEDURE FOR SETTING MAXIMUM TEMPERATURE POTENTIOMETER

NOTE: When replacing temp. control, turn oven temperature control to its maximum heat position and allow 30 minute preheat before calibrating. Connect temperature probe to the oven thermocouple leads at the temperature control board and adjust potentiometer to a maximum temperature of 600°F.(see diagram above)

HIGH LIMIT THERMOSTAT – REPLACEMENT

- A. Remove appropriate control box cover.
- B. Remove 2 wires from thermostat, note wire numbers and location for reinstallation
- C. Remove screws from bracket and remove thermostat.
- D. Reassemble in reverse order and check system operation.

NOTE: Depress reset button to insure thermostat is set for operation.

COOLING FAN MOTOR – REPLACEMENT

- A. Remove appropriate control box cover.
- B. Remove 4 mounting screws.
- C. Unplug electrical connector and remove fan motor.
- D. Reassemble in reverse order and check system operation.

MAIN FAN MOTOR – REPLACEMENT

- A. Shut off gas supply and remove gas line and manifold lines from back of oven.
- B. Remove screws from motor cover housing and lift off.
NOTE: When ovens are stacked, all motor cover housings are fastened together.
- C. Unplug power connector.
- D. Unplug thermocouple.
- E. Unplug 2 motor connectors.
- F. Remove 8 bolts from oven back (4 left, 4 right) and lift out.
- G. Remove 1 screw from fan hub and slide fan blade off of motor shaft.

- H. (note location of fan blade for reinstallation)
- I. Loosen lock nuts on cone. Remove 2 mounting bolts and remove motor from
- J. back assembly.
- K. Remove 4 hex head screws from motor mount bracket. Remove motor mount from motor and reinstall on new motor.
- L. Reassemble in reverse order.
- M. NOTE: 1. Make sure motor is centered in back housing.
- N. 2. Verify correct location of fan blade and that it is not hitting fan shroud.
- O. 3. Make sure all connectors are properly seated and making good contact.
- P. 4. When reinstalling gas manifold across back of oven, check all fittings for leaks.
- Q. Check system operation (allow 30 minute preheat for all checks) NOTE: Position of the fan on the motor shaft will be 1.875" from the top of the oven back cone to the blade spider assembly on the fan hub. (see drawing below).

THERMOCOUPLE (TYPE J) – REPLACEMENT

- A. Remove control box covers. Remove motor cover and remove oven back to access thermocouple.
NOTE: Removal of oven back assy. Is required to replace thermocouples.
- B. Remove thermocouple from wire form in oven chamber and remove from chamber. NOTE: R. H. thermocouple (viewed from front) is connected directly to the temperature control board, remove 2 wires , make note of wire colors and location. When changing L. H. thermocouple (viewed from front , the back motor cover must also be removed to gain access to the thermocouple connector plug.
- C. Reassemble in reverse order making sure bulb is placed securely in the wire form in the oven chamber.
- D. Check system operation, recalibrate as needed. NOTE: The R. H. and L. H. thermocouples have different connectors on the wire ends and must be ordered accordingly.

INFORMATION :

When two wires composed of dissimilar metals are joined together and one of the ends is heated, a continuous current flow is generated. We use an iron constant (type J) thermocouple. The iron wire increases the number of dissimilar junctions.

It is possible to check a thermocouple with a properly calibrated D. C. millivolt meter. At 32°F, the millivolt reading should be 0.00. This can be checked by inserting the thermocouple into an ice bath.

The millivolt reading at 72°F should be 1.134.

When using the following chart, the temperature at the terminal connections must be noted. This temperature is called the junction temperature.

The following chart lists the thermocouple millivolt readings from 200°F to 600°F.

		O V E N T E M P										
		200°F	250°F	300°F	325°F	350°F	400°F	425°F	450°F	500°F	550°F	600°F
J U N C T I O N	90°F	3.26	4.77	6.30	7.06	7.83	9.37	10.14	10.91	12.46	14.00	15.53
	88°F	3.32	4.83	6.36	7.12	7.89	9.43	10.20	10.97	12.51	14.05	15.59
	86°F	3.37	4.88	6.41	7.17	7.94	9.49	10.26	11.03	12.57	14.11	15.65
	84°F	3.43	4.94	6.47	7.23	8.00	9.54	10.31	11.09	12.63	14.19	15.71
	82°F	3.49	5.00	6.53	7.29	8.06	9.60	10.37	11.14	12.69	14.23	15.76
	80°F	3.55	5.06	6.59	7.35	8.12	9.66	10.43	11.20	12.74	14.28	15.82
	78°F	3.60	5.11	6.64	7.40	8.17	9.72	10.49	11.26	12.80	14.34	15.86
	76°F	3.66	5.17	6.70	7.46	8.23	9.77	10.55	11.32	12.86	14.40	15.94
	75°F	3.69	5.20	6.73	7.49	8.26	9.80	10.57	11.35	12.89	14.43	15.97
	74°F	3.72	5.23	6.76	7.52	8.29	9.83	10.60	11.37	12.92	14.46	15.99
T E M P	72°F	3.78	5.29	6.82	7.58	8.35	9.89	10.66	11.43	12.97	14.51	16.05
	70°F	3.83	5.34	6.87	7.63	8.40	9.95	10.72	11.49	13.03	14.57	16.11
	68°F	3.89	5.40	6.93	7.69	8.46	10.00	10.78	11.55	13.09	14.63	16.17
	66°F	3.95	5.46	6.99	7.75	8.52	10.06	10.83	11.61	13.15	14.69	16.23
	64°F	4.01	5.52	7.05	7.81	8.58	10.12	10.89	11.66	13.20	14.74	16.28
	62°F	4.06	5.57	7.10	7.86	8.63	10.18	10.95	11.72	13.26	14.80	16.34
	60°F	4.12	5.63	7.16	7.92	8.69	10.24	11.01	11.78	13.32	14.86	16.40

BEARING, CONVEYOR – REPLACEMENT

- A. Remove conveyor from oven and place on a flat work surface.
- B. Remove connecting links from conveyor belting. See Installation and Operating Instructions Manual.
- C. Remove conveyor belting from conveyor. Remove drive sprocket from drive shaft.
- D. Move drive shaft or idle shaft toward end of conveyor, and shaft with bearings will now slip out of holding bracket.
- E. Replace bearing and reassemble in reverse order.

This page intentionally left blank.

GENERAL PARTS ADVANTAGE SERIES

LETTER	PART #	DESCRIPTION
A	369110	Access window assembly
B	369929	Window retainer
C	369926	Window frame bottom
D	369925	Glass, access window
E	369927	Window frame, top
F	369930	Screw, 10-32x1/4
G	369211	Thumb screw
H	369058	Baffle
I	370253	Drive cover, L.H.
J	1609	Oven top
K	370252	Drive cover, R.H.
L	369745	Hinge assy., right
M	369723	Door assy., small
N	369783	Latch, spring
O	369717	Finger retaining bracket
P	369057	Screw, finger retaining bracket
Q	369501	Latch
R	369238	Leg
S	369030	Caster, High stand
	369390	Caster, Low stand
T	370167	Baffle, air return U.L., L.R. (S/N 35950 & Below)
	370663**	Baffle, air return U.L. (S/N 35951 & Above)
U	370166	Baffle, air return U.R., L.L. (S/N 35950 & Below)
	370662**	Baffle, air return U.R. (S/N 35951 & Above)
V	370168	Finger housing T-1, T-3, B-2, B-4 (S/N 35950 & Below)
	370665***	Finger housing T-1, T-3, B-2, B-4 (S/N 35951 & Above)
	370169	Finger housing T-2, T-4, B-1, B-3 (S/N 35950 & Below)
	370664***	Finger housing T-2, T-4, B-1, B-3 (S/N 35951 & Above)
W		Columnating plates- see Installation Operations manual.
X	369707	Finger cover
Y	369740	Handle assy.
Z	369718	Door assy. , large
AA	369931	Screw, 8-32x3/8
BB	369746	Hinge assy. , left

** Units from S/N 35951 and above DO NOT contain lower Air Return Baffles. These units only contain a total of two (2) Air Return Baffles which are placed above the top finger assemblies.

*** These parts have minor design changes not shown in the exploded view drawing on page 21.

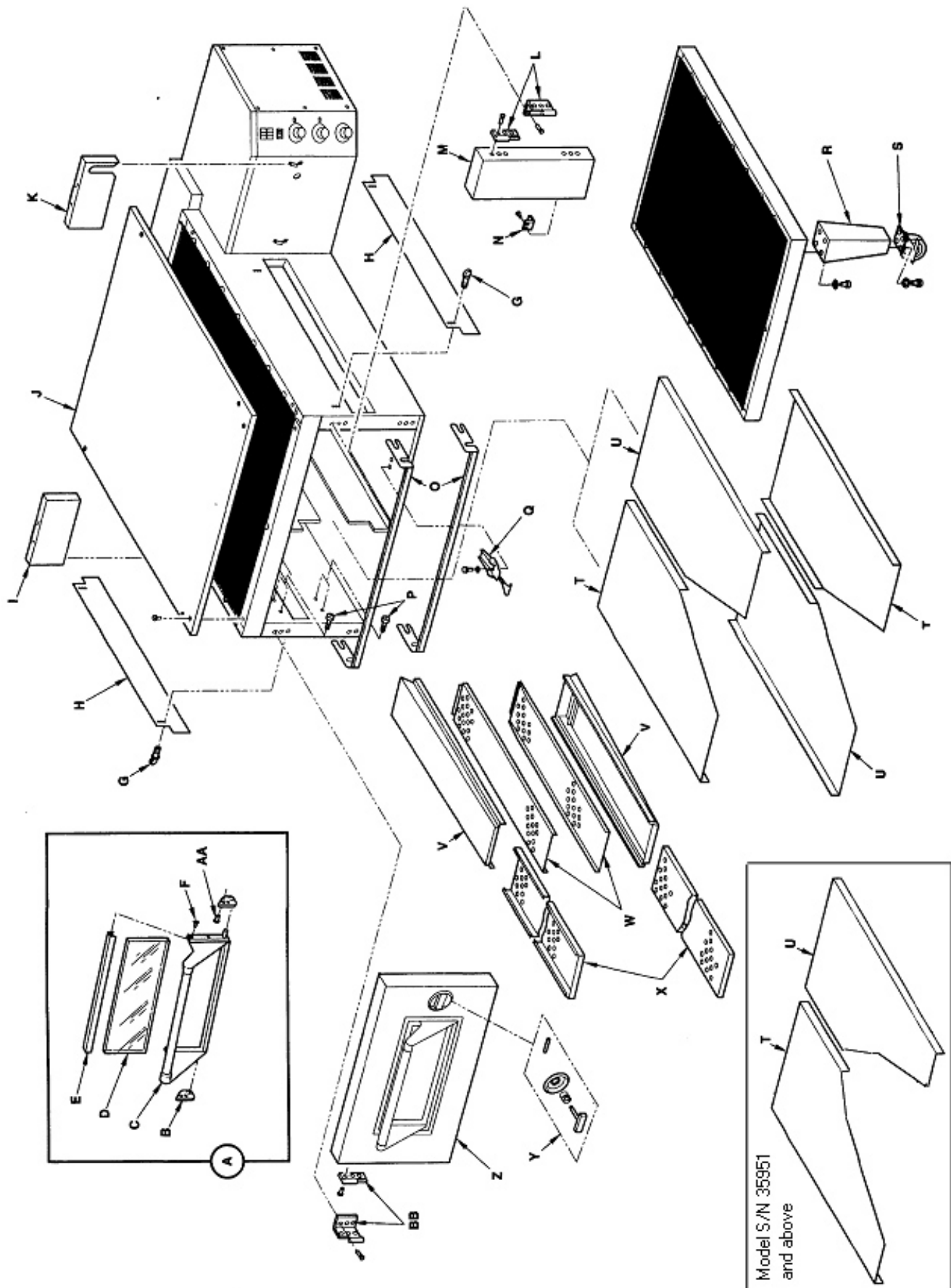

CONTROL BOX, RIGHT PARTS

1633-000-EA, 1634-000-EA

LETTER	PART#	DESCRIPTION
A	369158	Sprocket, 10 tooth
B	369705	Thermocouple
C	369757	Main orifice, Nat.
	369758	Main orifice, L.P.
D	370186	Solenoid valve
E	369590	Igniter/sensor assy.
F	369937	Venturi, Nat.
	369773	Venturi, L.P.
G	369401	Air shutter assy.
H	369589	Burner blower motor
I	369580	Gas valve
J	370031	By-pass orifice, Nat.
	369557	By-pass orifice, L.P.
K	369173	Transformer, temp. display
L	369571	Connector
M	370296	Wire hanger
N	367378	Cooling fan
O	369575	Air pressure switch
P	369154	Circuit breaker .7A
Q	369192	Capacitor
R	357107	Fuse holder
S	369013	Fuse, 3A
	369014	Fuse, 10A
T	369507	Thermostat, cooling fan
U	369431	Thermostat, control box hi-limit
V	370177	Conveyor control
W	369465	Temperature control
X	369573	Ignition control
Y	369856	Support stand-off
Z	369422	Relay
AA	369810	Cable, hall effect sensor
BB	369823	Hall effect sensor
CC	369824	Bracket, hall effect sensor
DD	369822	Magnet, 8 pole
EE	370244	Conveyor motor assy. (includes BB,CC,DD)
FF	370251	Control box top, R.H.
GG	370058	Jumper, thermocouple
HH	370249	Temperature display, dual
II	370256	Side panel, R.H.
JJ	369467	Pilot light, 250V.
KK	369449	Temperature control pot. assy.
LL	369809	Conveyor pot. assy.
MM	370277	Knob guard
NN	369432	Switch on/off
OO	369316	Knob

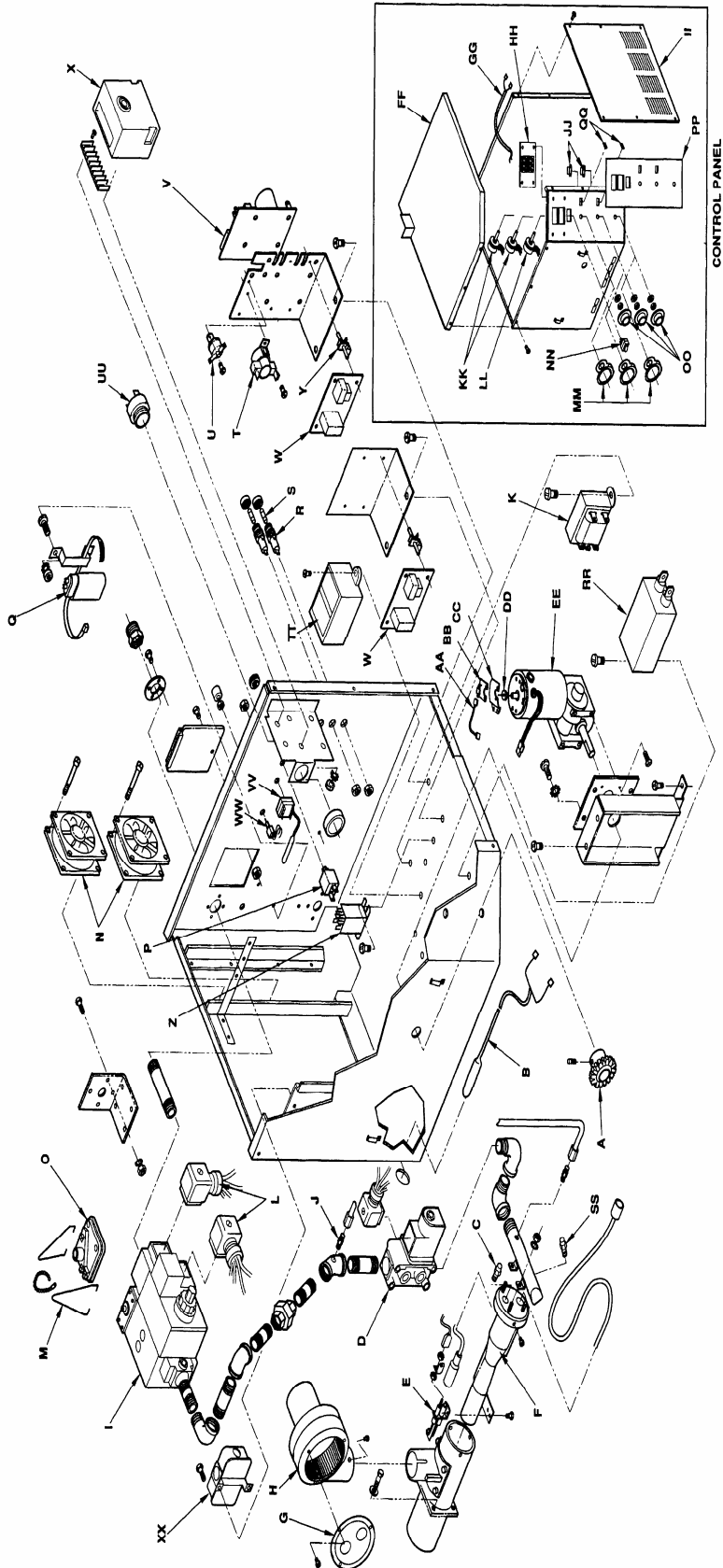

CONTROL BOX, LEFT PARTS

1633-000-EA, 1634-000-EA

LETTER	PART#	DESCRIPTION
A	369706	Thermocouple with extension
B	369507	Thermostat, cooling fan
C	369431	Thermostat, control box hi-limit
D	369573	Ignition control
E	369771	Reset switch, ignition control
F	357107	Fuse holder
G	369014	Fuse, 10A
H	369368	Thermostat, hi-limit
I	369378	cooling fan
J	369192	Capacitor
K	370296	Wire hanger
L	369575	Air pressure switch
M	369025	Air pressure switch
N	369580	Gas valve
O	369571	Connector
P	369589	Burner blower motor
Q	369590	Igniter/ sensor assy.
R	369937	Venturi, Nat.
	369773	Venturi, L.P.
S	369757	Main orifice, Nat.
	369758	main orifice, L.P.
T	369689	Pressure tap fitting
U	370186	Solenoid valve
V	370031	By-pass orifice, Nat.
	369557	By-pass orifice, L.P.
W	369574	Spark generator
X	370272	Side panel, L.H.
Y	370250	Control box top, L.H.
Z	369579	Alarm

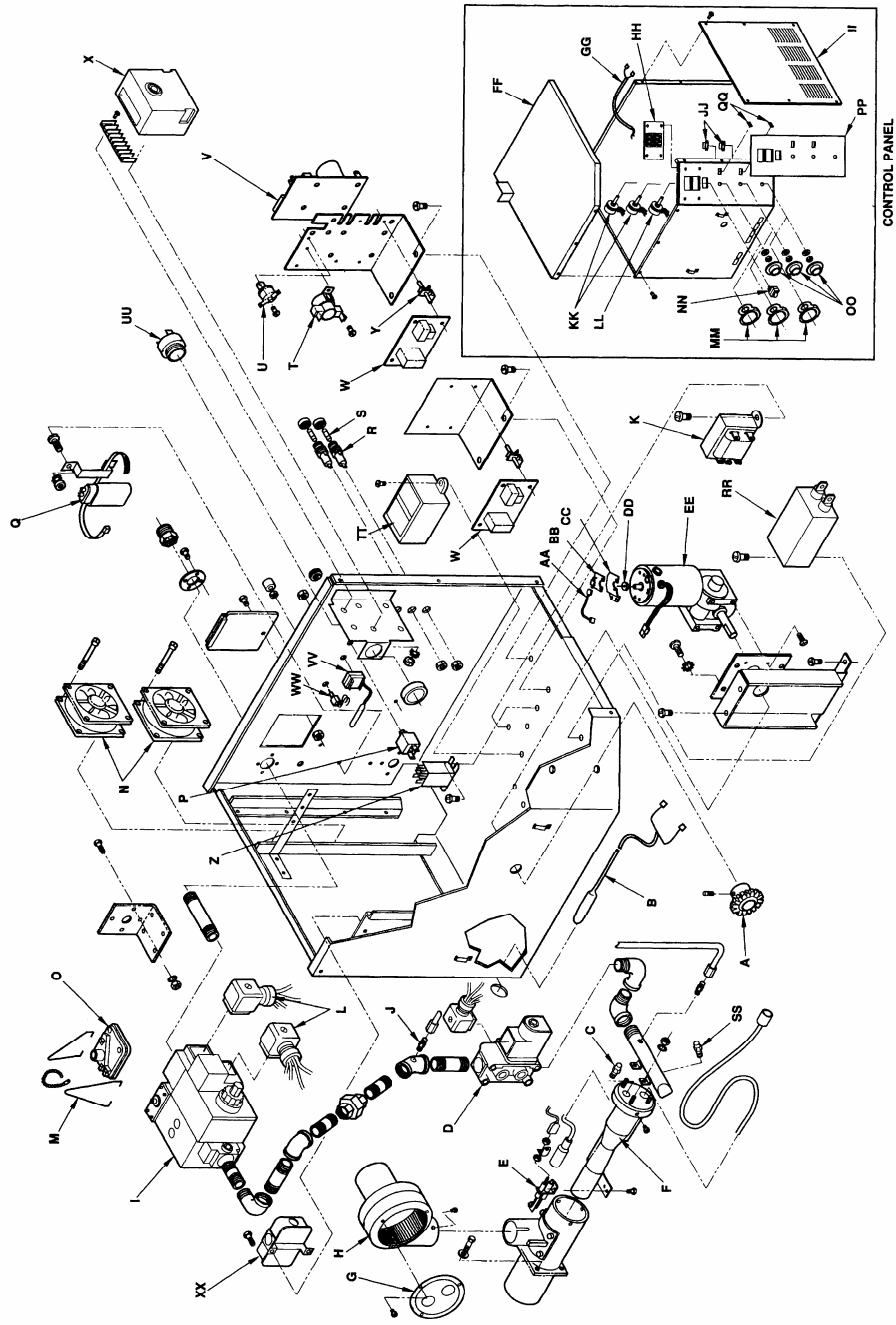

OVEN BACK PARTS

1633-000-EA, 1634-000-EA

LETTER	PART#	DESCRIPTION
A	369547	Wire form thermostat bulb
B	369724	Fan, clockwise rotation
C	369776	Fan shroud
D	369777	Stand-off
E	369778	Rear wall assy.
F	369761	Motor mount
G	369759	Motor, main fan 220/240V 50 Hz.
H	1627	Duct cap
I	369033	Motor clamp
J	370245	Rear duct
K	370246	Manifold assy.
L	368725	Fan, counter-clockwise rotation
M	369085	Junction box
N	369376	Terminal block 3-pole
O	353082	Ground lug
P	369698	Cover, junction box
Q	370184	Filter, RFI

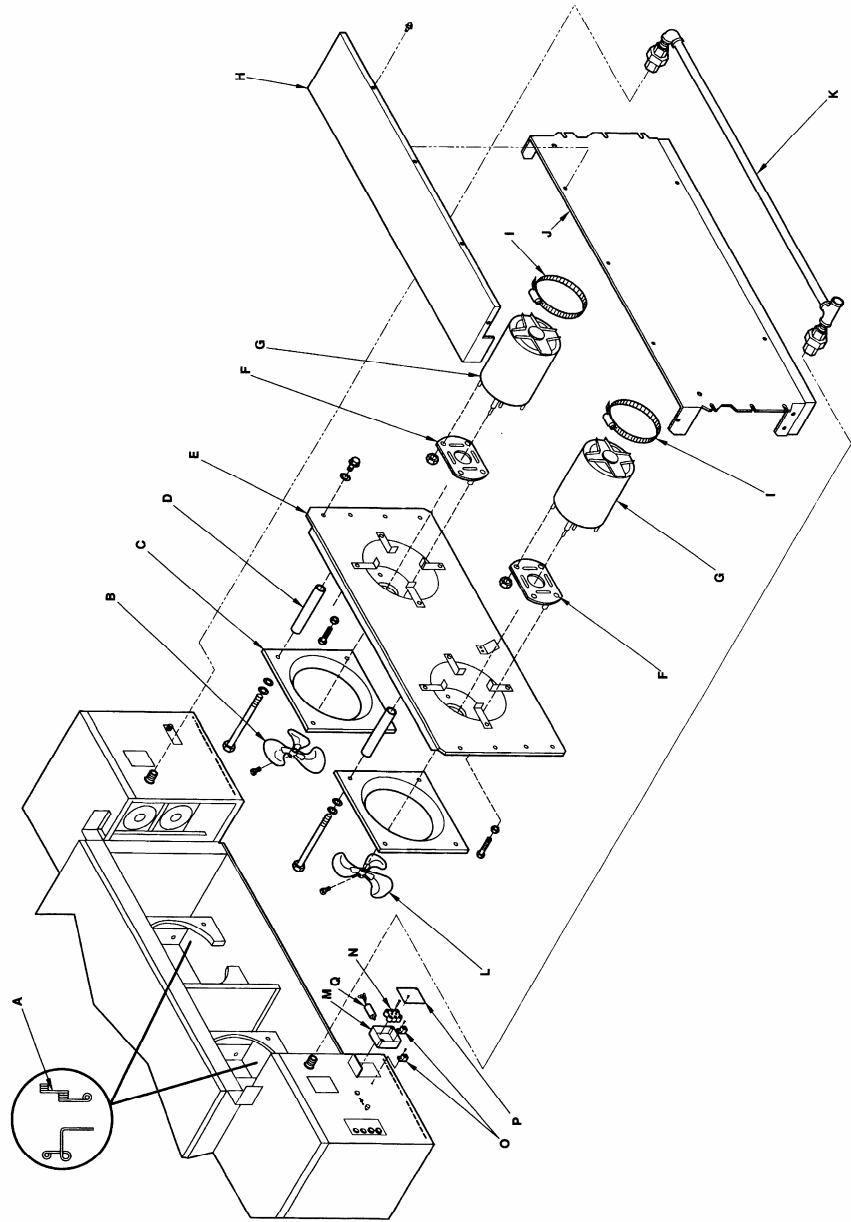

CONVEYOR PARTS 1633-000-EA, 1634-000-EA

LETTER	PART#	DESCRIPTION
	369830	Complete conveyor
A	369816	Conveyor belting
B	369825	Belt, 1ft. section
C	369813	Conveyor bearing block
D	369314	Roll, conveyor, notched
E	369812	Conveyor idler shaft
F	369160	Conveyor pan stop
G	369814	Connecting link
H	369811	Conveyor drive shaft
J	369161	Roller chain sprocket
K	369806	Crumb pan
L	370050	Conveyor frame
M	369162	Drive chain

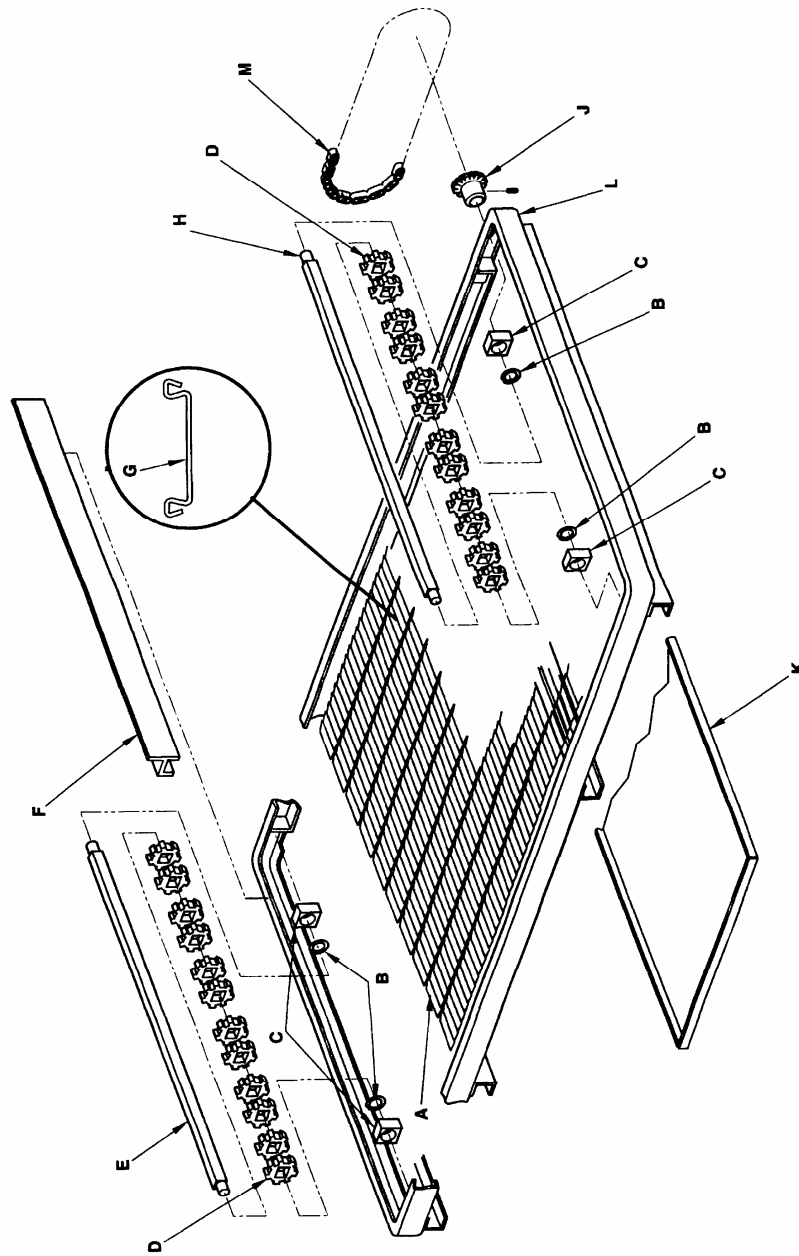

This page intentionally left blank.

This page intentionally left blank.

