

brother®

ADVANCED USER'S GUIDE

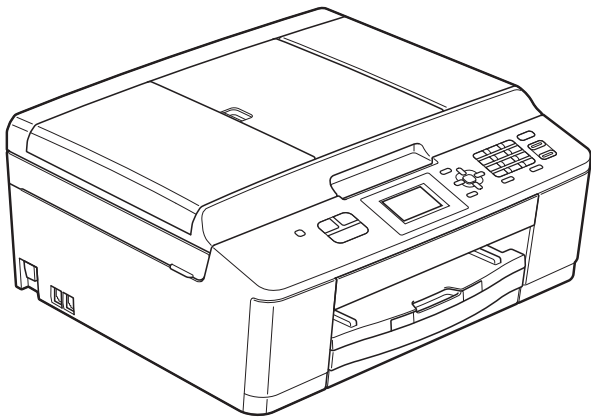

MFC-J425W
MFC-J430W
MFC-J435W

Version 0

USA/CAN

User's Guides and where do I find it?

Which manual?	What's in it?	Where is it?
Product Safety Guide	Read this Guide first. Please read the Safety Instructions before you set up your machine. See this Guide for trademarks and legal limitations.	Printed / In the box
Quick Setup Guide	Follow the instructions for setting up your machine and installing the drivers and software for the operating system and connection type you are using.	Printed / In the box
Basic User's Guide	Learn the basic Fax, Copy and Scan operations and how to replace consumables. See troubleshooting tips.	Printed / In the box
Advanced User's Guide	Learn more advanced operations: Fax, Copy, security features, printing reports and performing routine maintenance.	PDF file / CD-ROM
Software User's Guide	Follow these instructions for Printing, Scanning, Network Scanning, PC-Fax Send, Web Services (Scan), and using the Brother ControlCenter utility.	PDF file / CD-ROM
Network Glossary	This Guide provides basic information about advanced network features of Brother machines along with explanations about general networking and common terms.	PDF file / CD-ROM
Network User's Guide	This Guide provides useful information about wireless network settings and security settings using the Brother machine. You can also find supported protocol information for your machine and detailed troubleshooting tips.	PDF file / CD-ROM
Mobile Print/Scan Guide	This Guide provides useful information about printing data from your mobile phone and transmitting scanned data from the Brother machine to your mobile phone.	PDF file / Brother Solutions Center ¹

¹ Visit us at <http://solutions.brother.com/>.

Table of Contents

1	General setup	1
	IMPORTANT NOTE.....	1
	Memory storage.....	1
	Volume Settings.....	1
	Ring Volume.....	1
	Beeper Volume.....	2
	Speaker Volume.....	2
	Automatic Daylight Saving Time.....	3
	Sleep Mode.....	3
	LCD screen.....	4
	LCD Contrast.....	4
	Setting the backlight brightness.....	4
	Setting the Dim Timer for the backlight.....	4
	Mode Timer.....	5
2	Security features	6
	TX Lock.....	6
	Setting and changing the TX Lock password.....	6
	Turning TX Lock on/off.....	7
3	Sending a fax	8
	Additional sending options.....	8
	Sending faxes using multiple settings.....	8
	Stop faxing.....	8
	Contrast.....	8
	Changing fax resolution.....	9
	Setting your changes as the new default.....	9
	Restoring fax settings to the factory settings.....	9
	Additional sending operations.....	10
	Sending a fax manually.....	10
	Sending a fax at the end of a conversation.....	10
	Dual Access (Black & White only).....	10
	Broadcasting (Black & White only).....	11
	Real Time Transmission.....	12
	Overseas Mode.....	13
	Checking and canceling waiting jobs.....	13
4	Receiving a fax	14
	Additional receiving operations.....	14
	Printing a reduced incoming fax.....	14
	Receiving a fax at the end of a conversation.....	14
	Receiving faxes into memory when paper tray is empty.....	14

5	Dialing and storing numbers	15
	Voice operations	15
	Tone or Pulse (Canada only).....	15
	Fax/Tel mode.....	15
	Caller ID.....	15
	Special line considerations	16
	Additional dialing operations.....	18
	Outgoing Call.....	18
	Caller ID history	18
	Dialing access codes and credit card numbers	19
	Additional ways to store numbers.....	20
	Storing Speed Dial numbers from Outgoing Calls.....	20
	Storing Speed Dial numbers from the Caller ID history.....	20
	Setting up Groups for Broadcasting	21
6	Printing reports	23
	Fax reports.....	23
	Transmission Verification Report.....	23
	Fax Journal (activity report)	23
	Reports	24
	How to print a report	24
7	Making copies	25
	Copy settings	25
	Stop copying.....	25
	Changing copy quality	25
	Enlarging or reducing the copied image.....	26
	Making N in 1 copies or a poster (Page Layout)	27
	2 in 1 ID Copy.....	28
	Sorting copies using the ADF	29
	Adjusting Density.....	29
	Setting your changes as the new default.....	29
	Restoring all settings to the factory settings	30
A	Routine maintenance	31
	Cleaning and checking the machine.....	31
	Cleaning the outside of the machine	31
	Cleaning the machine's printer platen	32
	Cleaning the paper pick-up rollers.....	32
	Checking the ink volume	33
	Packing and shipping the machine	34
B	Glossary	37
C	Index	40

IMPORTANT NOTE

- In this manual, the LCD messages of the MFC-J430W are used unless specified.
- Most of the illustrations in this User's Guide show the MFC-J430W.





Memory storage

Even if there is a power failure, you will not lose the settings you have chosen using the **Menu** key because they are stored permanently. Also, you will not lose your settings in the **FAX** and **COPY** mode key menus if you have chosen `Set New Default`. You may have to reset the date and time.

Volume Settings

Ring Volume

You can choose a range of ring volume levels, from `High` to `Off`.

While the machine is idle, press   or   to adjust the volume level. The LCD shows the current setting, and each key press will change the volume to the next level. The machine will keep the new setting until you change it.

You can also change the volume through the menu, by following the instructions below:

Setting the Ring Volume from the menu

- 1 Press **Menu**.
- 2 Press **▲** or **▼** to choose `General Setup`. Press **OK**.
- 3 Press **▲** or **▼** to choose `Volume`. Press **OK**.
- 4 Press **▲** or **▼** to choose `Ring`. Press **OK**.
- 5 Press **▲** or **▼** to choose `Low`, `Med`, `High` or `Off`. Press **OK**.
- 6 Press **Stop/Exit**.

Beeper Volume

When the beeper is on, the machine will beep when you press a key, make a mistake, or after you send or receive a fax.

You can choose a range of beeper volume levels, from *High* to *Off*.



- 1 Press **Menu**.
- 2 Press ▲ or ▼ to choose *General Setup*. Press **OK**.
- 3 Press ▲ or ▼ to choose *Volume*. Press **OK**.
- 4 Press ▲ or ▼ to choose *Beeper*. Press **OK**.
- 5 Press ▲ or ▼ to choose *Low, Med, High* or *Off*. Press **OK**.
- 6 Press **Stop/Exit**.

Speaker Volume

You can choose a range of speaker volume levels, from *High* to *Off*.

- 1 Press **Menu**.
- 2 Press ▲ or ▼ to choose *General Setup*. Press **OK**.
- 3 Press ▲ or ▼ to choose *Volume*. Press **OK**.
- 4 Press ▲ or ▼ to choose *Speaker*. Press **OK**.
- 5 Press ▲ or ▼ to choose *Low, Med, High* or *Off*. Press **OK**.
- 6 Press **Stop/Exit**.

You can also adjust the speaker volume by pressing **Hook**.

- 1 Press **Hook**.
- 2 Press  ◀ or ▶ . Each key press changes the volume to the next setting. This setting will stay until you change it again.
- 3 Press **Hook**.

Automatic Daylight Saving Time

You can set the machine to change automatically for daylight saving time. It will reset itself forward one hour in the Spring and backward one hour in the Fall. Make sure you have set the correct date and time in the `Date&Time` setting.

The factory setting is `Off`, so you will have to turn on Automatic Daylight Saving Time as follows.

- 1 Press **Menu**.
- 2 Press **▲** or **▼** to choose `General Setup`. Press **OK**.
- 3 Press **▲** or **▼** to choose `Auto Daylight`. Press **OK**.
- 4 Press **▲** or **▼** to choose `On` (or `Off`). Press **OK**.
- 5 Press **Stop/Exit**.

Sleep Mode

You can choose how long the machine must be idle (up to 60 minutes) before it goes into Sleep Mode. The timer will restart if any operation is carried out on the machine.

- 1 Press **Menu**.
- 2 Press **▲** or **▼** to choose `General Setup`. Press **OK**.
- 3 Press **▲** or **▼** to choose `Sleep Mode`. Press **OK**.
- 4 Press **▲** or **▼** to choose `1Min`, `2Mins`, `3Mins`, `5Mins`, `10Mins`, `30Mins` or `60Mins` to choose which is the length of time the machine is idle before entering sleep mode. Press **OK**.
- 5 Press **Stop/Exit**.

LCD screen

LCD Contrast

You can adjust the LCD contrast. If you are having difficulty reading the LCD, try changing the contrast setting.

- 1 Press **Menu**.
- 2 Press **▲** or **▼** to choose **General Setup**. Press **OK**.
- 3 Press **▲** or **▼** to choose **LCD Settings**. Press **OK**.
- 4 Press **▲** or **▼** to choose **LCD Contrast**. Press **OK**.
- 5 Press **◀** to increase the contrast or press **▶** to decrease the contrast. Press **OK**.
- 6 Press **Stop/Exit**.

Setting the backlight brightness

You can adjust the brightness of the LCD backlight. If you are having difficulty reading the LCD, try changing the brightness setting.

- 1 Press **Menu**.
- 2 Press **▲** or **▼** to choose **General Setup**. Press **OK**.
- 3 Press **▲** or **▼** to choose **LCD Settings**. Press **OK**.
- 4 Press **▲** or **▼** to choose **Backlight**. Press **OK**.
- 5 Press **▲** or **▼** to choose **Light, Med or Dark**. Press **OK**.
- 6 Press **Stop/Exit**.

Setting the Dim Timer for the backlight

You can set how long the LCD backlight stays on after you go back to the Ready screen.

- 1 Press **Menu**.
- 2 Press **▲** or **▼** to choose **General Setup**. Press **OK**.
- 3 Press **▲** or **▼** to choose **LCD Settings**. Press **OK**.
- 4 Press **▲** or **▼** to choose **Dim Timer**. Press **OK**.
- 5 Press **▲** or **▼** to choose **10Secs, 20Secs, 30Secs or Off**. Press **OK**.
- 6 Press **Stop/Exit**.

Mode Timer

The machine has three temporary mode keys on the control panel: **FAX**, **SCAN** and **COPY**. You can change the amount of time the machine takes after the last Scan or Copy operation before it returns to FAX mode. If you choose **Off**, the machine stays in the mode you used last.



- 1 Press **Menu**.
- 2 Press **▲** or **▼** to choose **General Setup**. Press **OK**.
- 3 Press **▲** or **▼** to choose **Mode Timer**. Press **OK**.
- 4 Press **▲** or **▼** to choose **0Sec**, **30Secs**, **1Min**, **2Mins**, **5Mins** or **Off**. Press **OK**.
- 5 Press **Stop/Exit**.

TX Lock

TX Lock lets you prevent unauthorized access to the machine.

While TX Lock is On, the following operations are available:

- Receiving faxes

While TX Lock is On, the following operations are NOT available:

- Sending faxes
- Copying
- PC printing
- Scanning
- Operation from the control panel



Note

If you forget the TX Lock password, please call Brother Customer Service. (►►Basic User's Guide: *Brother numbers*)

Setting and changing the TX Lock password



Note

If you have already set the password, you will not need to set it again.

Setting the password

Make a careful note of your password.

- 1 Press **Menu**.
- 2 Press **▲** or **▼** to choose **Fax**. Press **OK**.
- 3 Press **▲** or **▼** to choose **Miscellaneous**. Press **OK**.
- 4 Press **▲** or **▼** to choose **TX Lock**. Press **OK**.
- 5 Enter a 4-digit number for the password. Press **OK**.
- 6 When the LCD shows **Verify:** re-enter the password. Press **OK**.
- 7 Press **Stop/Exit**.

Changing the password

- 1 Press **Menu**.
- 2 Press **▲** or **▼** to choose `Fax`. Press **OK**.
- 3 Press **▲** or **▼** to choose `Miscellaneous`. Press **OK**.
- 4 Press **▲** or **▼** to choose `TX Lock`. Press **OK**.
- 5 Press **▲** or **▼** to choose `Set Password`. Press **OK**.
- 6 Enter the 4-digit number of the current password. Press **OK**.
- 7 Enter a 4-digit number for the new password. Press **OK**.
- 8 When the LCD shows `Verify:` re-enter the new password. Press **OK**.
- 9 Press **Stop/Exit**.

Turning TX Lock on/off

Turning TX Lock on

- 1 Press **Menu**.
- 2 Press **▲** or **▼** to choose `Fax`. Press **OK**.
- 3 Press **▲** or **▼** to choose `Miscellaneous`. Press **OK**.
- 4 Press **▲** or **▼** to choose `TX Lock`. Press **OK**.
- 5 Press **▲** or **▼** to choose `Set TX Lock`. Press **OK**.
- 6 Enter the registered 4-digit password. Press **OK**.
The machine goes offline and the LCD shows `TX Lock Mode`.

Turning TX Lock off

- 1 Press **Menu**.
- 2 Enter the registered 4-digit password. Press **OK**.
TX Lock is automatically turned off.



Note

If you enter the wrong password, the LCD shows `Wrong Password` and stays offline. The machine will stay in TX Lock mode until the registered password is entered.

3

Sending a fax

Additional sending options

Sending faxes using multiple settings

When you send a fax you can choose a combination of settings, such as Fax Resolution, Contrast, Glass ScanSize, and Real Time TX.

You can also choose: Outgoing Call, Caller ID hist., Overseas Mode, Speed Dial, Broadcasting, Set New Default, and Factory Reset.

Some settings are only available when sending black & white faxes.

- 1 Press  (FAX).
The LCD shows:

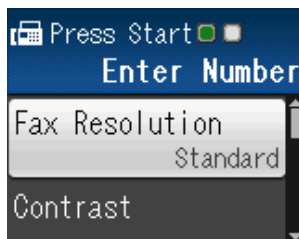

- 2 Press **▲** or **▼** to choose the setting you want to change.
Press **OK**.
- 3 Press **▲** or **▼** to choose an option.
Press **OK**.
- 4 Repeat steps 2 to 3 to change more settings.

Note

- Most settings are temporary and the machine returns to its default settings after you send a fax.
- You can save some of the settings you use most often by setting them as the default. These settings will stay until you change them again. (See *Setting your changes as the new default* >> page 9.)

Stop faxing

To stop faxing, press **Stop/Exit**.

Contrast

If your document is very light or very dark, you may want to change the contrast. For most documents the factory setting **Auto** can be used. It automatically chooses the suitable contrast for your document.

Choose **Light** when sending a light document. Choose **Dark** when sending a dark document.

- 1 Press  (FAX).
- 2 Press **▲** or **▼** to choose **Contrast**.
Press **OK**.
- 3 Press **▲** or **▼** to choose **Auto**, **Light** or **Dark**.
Press **OK**.

Note

Even if you choose **Light** or **Dark**, the machine will send the fax using the **Auto** setting in any of the following conditions:

- When you send a color fax.
- When you choose **Photo** as the Fax Resolution.

Changing fax resolution

The quality of a fax can be improved by changing the fax resolution.

- 1 Press  (FAX).
- 2 Press ▲ or ▼ to choose Fax Resolution.
Press **OK**.
- 3 Press ▲ or ▼ to choose the resolution you want.
Press **OK**.



Note

You can choose four different resolution settings for black & white faxes and two for color faxes.

Black & White	
Standard	Suitable for most typed documents.
Fine	Good for small print and transmits a little slower than Standard resolution.
S.Fine	Good for small print or artwork and transmits slower than Fine resolution.
Photo	Use when the document has varying shades of gray or is a photograph. Photo has the slowest transmission.

Color	
Standard	Suitable for most typed documents.
Fine	Use when the document is a photograph. The transmission time is slower than Standard resolution.

If you choose *S.Fine* or *Photo* and then use the **Color Start** key to send a fax, the machine will send the fax using the *Fine* setting.

Setting your changes as the new default

You can save the fax settings for Fax Resolution, Contrast, Glass ScanSize and Real Time TX you use most often by setting them as default. These settings will stay until you change them again.

- 1 Press  (FAX).
- 2 Press ▲ or ▼ to choose the setting you want to change, and press **OK**. Then press ▲ or ▼ to choose your new option.
Press **OK**.

Repeat this step for each setting you want to change.

- 3 After changing the last setting, press ▲ or ▼ to choose Set New Default.
Press **OK**.
- 4 Press **1** to choose Yes.
- 5 Press **Stop/Exit**.

Restoring fax settings to the factory settings

You can restore the fax settings Fax Resolution, Contrast, Glass ScanSize, and Real Time TX, that you have changed, to the factory settings. These settings will stay until you change them again.

- 1 Press  (FAX).
- 2 Press ▲ or ▼ to choose Factory Reset.
Press **OK**.
- 3 Press **1** to choose Yes.
- 4 Press **Stop/Exit**.

Additional sending operations

Sending a fax manually

Manual transmission lets you hear the dialing, ringing and fax-receiving tones while sending a fax.



Note

To send a multiple page fax, use the ADF.

- 1 Press  (**FAX**).
- 2 Load your document.
- 3 To listen for a dial tone, press **Hook**.
- 4 Dial the fax number.
- 5 When you hear the fax tone, press **Black Start** or **Color Start**.
If you are using the scanner glass press **1** to send the fax.

Sending a fax at the end of a conversation

At the end of a conversation, you can send a fax to the other party before you both hang up.

- 1 Ask the other party to wait for fax tones (beeps) and then to press the Start or Send key before hanging up.
- 2 Press  (**FAX**).
- 3 Load your document.
- 4 Press **Black Start** or **Color Start**.
 - If you are using the scanner glass, press **1** to send a fax.
- 5 Replace the handset of the external phone.

Dual Access (Black & White only)

You can dial a number and start scanning the fax into memory—even when the machine is sending from memory, receiving faxes or printing PC data. The LCD shows the new job number.

The number of pages you can scan into the memory will vary depending on the data that is printed on them.



Note

If the `Out of Memory` message appears while scanning a document, press **Stop/Exit** to cancel or **Black Start** to send the scanned pages.

Broadcasting (Black & White only)

Broadcasting is when the same fax message is automatically sent to more than one fax number. You can include Groups, Speed Dial numbers, and up to 50 manually dialed numbers in the same broadcast.

After the broadcast is finished, a Broadcast Report will be printed.

Before you begin the broadcast

Speed Dial numbers must be stored in the machine's memory before they can be used in a broadcast. (►►Basic User's Guide: *Storing Speed Dial numbers*)

Group numbers must also be stored in the machine's memory before they can be used in a broadcast. Group numbers include many stored Speed Dial numbers for easier dialing. (See *Setting up Groups for Broadcasting* ►► page 21.)

How to broadcast a fax

- 1 Press  (FAX).
- 2 Load your document.
- 3 Press ▲ or ▼ to choose *Advanced Settings*. Press **OK**.
- 4 Press ▲ or ▼ to choose *Broadcasting*. Press **OK**.

- 5 You can add numbers to the broadcast in the following ways:

- Press ▲ or ▼ to choose *Add Number* and press **OK**. Enter a number using the dial pad.

Press **OK**.

- Press ▲ or ▼ to choose *Speed Dial* and press **OK**.

Press ▲ or ▼ to choose *Alphabetical Order* or *Numerical Order* and press **OK**. Press ▲ or ▼ to select a number and press **OK**.

- 6 After you have entered all the fax numbers by repeating step 5, press ▲ or ▼ to choose *Complete*. Press **OK**.

- 7 Press **Black Start**.

Faxing from the ADF

- The machine starts scanning and sending the document.

Faxing from the scanner glass

When the LCD asks you *Next Page?*, do one of the following:

- To send a single page, press **2** (or press **Black Start** again).

The machine starts sending the document.

- To send more than one page, press **1** and place the next page on the scanner glass.

Press **OK**.

The machine starts scanning the page. (Repeat this step for each additional page.)

**Note**

- If you did not use up any of the numbers for Groups, you can broadcast faxes to as many as 90 different numbers.
- The machine's available memory will vary depending on the types of jobs in the memory and the number of locations used for broadcasting. If you broadcast to the maximum number available, you will not be able to use dual access.
- If the *Out of Memory* message appears, press **Stop/Exit** to stop the job. If more than one page has been scanned, press **Black Start** to send the portion that is in the machine's memory.

Canceling a broadcast in progress

- 1 Press **Menu**.
- 2 Press **▲** or **▼** to choose *Fax*. Press **OK**.
- 3 Press **▲** or **▼** to choose *Remaining Jobs*. Press **OK**.
The LCD will show the fax number being dialed and the Broadcasting job number.
- 4 Press **OK**.
The LCD will ask you the following question:
Cancel Job?
Yes → Press 1
No → Press 2
- 5 Press **1** to cancel the fax number being dialed.
The LCD will then show the Broadcasting job number.
- 6 Press **OK**.
The LCD will ask you the following question:
Cancel Job?
Yes → Press 1
No → Press 2

- 7 To cancel the broadcast, press **1**.
- 8 Press **Stop/Exit**.

Real Time Transmission

When you are sending a fax, the machine will scan the document into the memory before sending it. Then, as soon as the telephone line is free, the machine will start dialing and sending.

Sometimes, you may want to send an important document immediately, without waiting for memory transmission. You can do this by turning on *Real Time TX*.

- 1 Press  (**FAX**).
- 2 Load your document.
- 3 Press **▲** or **▼** to choose *Advanced Settings*. Press **OK**.
- 4 Press **▲** or **▼** to choose *Real Time TX*. Press **OK**.
- 5 Press **▲** or **▼** to choose *On* (or *Off*). Press **OK**.
- 6 Press **Clear** so you can continue sending your fax.

**Note**

- If you are sending a color fax or if the memory is full and you are sending a black & white fax from the ADF, the machine will send the document in real time (even if *Real Time TX* is set to *Off*).
- In Real Time Transmission, the automatic redial feature does not work when you are using the scanner glass.

Overseas Mode

If you are having difficulty sending a fax overseas due to possible interference on the telephone line, we recommend that you turn on Overseas Mode. After you send a fax using this feature, the feature will turn itself off.

- 1 Press  (FAX).
- 2 Load your document.
- 3 Press ▲ or ▼ to choose *Advanced Settings*. Press **OK**.
- 4 Press ▲ or ▼ to choose *Overseas Mode*. Press **OK**.
- 5 Press ▲ or ▼ to choose *On (or Off)*. Press **OK**.
- 6 Press **Clear** so you can continue sending your fax.

Checking and canceling waiting jobs

You can check which jobs are still waiting in the memory to be sent and cancel a job. (If there are no jobs, the LCD shows *No Jobs Waiting*.)

- 1 Press **Menu**.
- 2 Press ▲ or ▼ to choose *Fax*. Press **OK**.
- 3 Press ▲ or ▼ to choose *Remaining Jobs*. Press **OK**. Any waiting jobs appear on the LCD.
- 4 Press ▲ or ▼ to scroll through the jobs and choose the job you want to cancel. Press **OK**.
- 5 Do one of the following:
 - To cancel, press **1** to choose *Yes*. If you want to cancel another job go to step 4.
 - To exit without canceling, press **2** to choose *No*.
- 6 Repeat steps 4 and 5 for each job you want to cancel.
- 7 When you are finished, press **Stop/Exit**.

4

Receiving a fax

Additional receiving operations

Printing a reduced incoming fax

If you choose `On`, the machine automatically reduces each page of an incoming fax to fit on one page of Letter, Legal or A4 size paper. The machine calculates the reduction ratio by using the page size of the fax and your Paper Size setting. (►►Basic User's Guide: *Paper Size*)

- 1 Press **Menu**.
- 2 Press **▲** or **▼** to choose `Fax`. Press **OK**.
- 3 Press **▲** or **▼** to choose `Setup Receive`. Press **OK**.
- 4 Press **▲** or **▼** to choose `Auto Reduction`. Press **OK**.
- 5 Press **▲** or **▼** to choose `On` (or `Off`). Press **OK**.
- 6 Press **Stop/Exit**.

Receiving a fax at the end of a conversation

At the end of a conversation, you can ask the other party to fax you information before you both hang up.

- 1 Ask the other party to place the document in their machine and to press the **Start** or **Send** key.
- 2 When you hear the other machine's CNG tones (slowly repeating beeps), press **Black Start** or **Color Start**.
- 3 Press **2** to choose `Receive` to receive the fax.
- 4 Replace the handset of the external telephone.

Receiving faxes into memory when paper tray is empty

As soon as the paper tray becomes empty during fax reception, the LCD shows `No Paper Fed`. Put some paper in the paper tray. (►►Basic User's Guide: *Loading paper and other print media*)

If you don't put paper in the paper tray, the machine will carry on receiving the fax, with the remaining pages being stored in memory, if enough memory is available.

Further incoming faxes will also be stored in memory until the memory is full. When the memory is full the machine will stop automatically answering calls. To print the faxes, put fresh paper in the tray.

Voice operations

Voice calls can be made with an external telephone by dialing manually.

Tone or Pulse (Canada only)

If you have a Pulse dialing service, but need to send tone signals (for example, for telephone banking), follow the instructions below:

- 1 Press **Hook**.
- 2 Press **#** on the machine's control panel. Any digits dialed after this will send tone signals.

When you are finished with the call, the machine will return to the Pulse dialing service.

Fax/Tel mode

When the machine is in Fax/Tel mode, it will use the F/T Ring (pseudo/double-ringing) to alert you to pick up a voice call.

If you are at the extension telephone, you'll need to lift the handset during the F/T Ring and then press **# 5 1** between the pseudo/double-rings. If no one is on the line, or if someone wants to send you a fax, send the call back to the machine by pressing *** 5 1**.

If you are at the machine, lift the external telephone's handset, and then press **Hook** to answer.

Caller ID

The Caller ID feature lets you use the Caller ID subscriber service offered by many local telephone companies. This service shows the telephone number, or name if it is available, of your caller as the line rings. Call your telephone company for details.

Once you answer a call, the Caller ID information disappears from the LCD, but the call information stays stored in the Caller ID memory.

You can view the list or choose one of these numbers to fax to, add to Speed Dial, or delete from the history. (See *Caller ID history* >> page 18.)

- You can see the number (or name).
- The # `Unavailable` message means the call originated outside your Caller ID service area.
- The `Private Call` message means the caller has intentionally blocked transmission of Caller ID information.

You can print a list of the Caller ID information received by your machine. (See *How to print a report* >> page 24.)



Note

- This feature may not be available in certain areas of the USA and Canada.
- The Caller ID service varies with different carriers. Call your local telephone company to find out about the kind of service available in your area.

Setting up your area code (USA only)

When returning calls from the Caller ID history your machine will automatically dial “1” plus the area code for all calls. If your local dialing plan requires that the “1” not be used for calls within your area code, enter your area code in this setting. With the area code setting, calls returned from the Caller ID history to numbers *within* your area code will be dialed using 10 digits (area code + 7-digit number). If your dialing plan does not follow the standard 1 + area code + 7-digit number dialing system for calling *outside* your area code, you may experience problems returning calls automatically from the Caller ID history. If this is not the procedure followed by your dialing plan, you will not be able to return calls automatically.

- 1 Press **Menu**.
- 2 Press **▲** or **▼** to choose **Fax**. Press **OK**.
- 3 Press **▲** or **▼** to choose **Miscellaneous**. Press **OK**.
- 4 Press **▲** or **▼** to choose **Caller ID**. Press **OK**.
- 5 Use the dial pad to enter your area code. Press **OK**.
- 6 Press **Stop/Exit**.

Special line considerations

Roll-over telephone lines

A roll-over telephone system is a group of two or more separate telephone lines that pass incoming calls to each other if they are busy. The calls are usually passed down or “rolled over” to the next available telephone line in a preset order.

Your machine can work in a roll-over system as long as it is the last number in the sequence so the call cannot roll away. Do not put the machine on any of the other numbers; when the other lines are busy and a second fax call is received, the fax call will be sent to a line that does not have a fax machine. **Your machine will work best on a dedicated line.**

Two-line telephone system

A two-line telephone system is nothing more than two separate telephone numbers on the same wall outlet. The two telephone numbers can be on separate jacks (RJ11) or mixed into one jack (RJ14). Your machine must be plugged into an RJ11 jack. RJ11 and RJ14 jacks may be equal in size and appearance and both may contain four wires (black, red, green, yellow). To test the type of jack, plug in a two-line telephone and see if it can access both lines. If it can, you must separate the line for your machine.

Converting telephone wall outlets

There are three ways to convert to an RJ11 jack. The first two ways may require help from the telephone company. You can change the wall outlets from one RJ14 jack to two RJ11 jacks. Or, you can have an RJ11 wall outlet installed and slave or jump one of the telephone numbers to it.

The third way is the easiest: Buy a triplex adapter. You can plug a triplex adapter into an RJ14 outlet. It separates the wires into two separate RJ11 jacks (Line 1, Line 2) and a third RJ14 jack (Lines 1 and 2). If your machine is on Line 1, plug the machine into L1 of the triplex adapter. If your machine is on Line 2, plug it into L2 of the triplex adapter.

Triplex Adapter

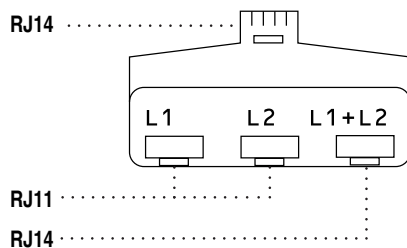

Installing machine, external two-line TAD and two-line telephone

When you are installing an external two-line telephone answering device (TAD) and a two-line telephone, your machine must be isolated on one line at both the wall jack and at the TAD. The most common connection is to put the machine on Line 2, which is explained in the following steps. The back of the two-line TAD must have two telephone jacks: one labeled L1 or L1/L2, and the other labeled L2. You will need at least three telephone line cords: the one that came with your machine and two for your external two-line TAD. You will need a fourth line cord if you add a two-line telephone.

- 1 Put the two-line TAD and the two-line telephone next to your machine.

- 2 Plug one end of the telephone line cord for your machine into the L2 jack of the triplex adapter. Plug the other end into the LINE jack on the back of the machine.
- 3 Plug one end of the first telephone line cord for your TAD into the L1 jack of the triplex adapter. Plug the other end into the L1 or L1/L2 jack of the two-line TAD.
- 4 Plug one end of the second telephone line cord for your TAD into the L2 jack of the two-line TAD. Plug the other end into the EXT. jack on the left side of the machine.

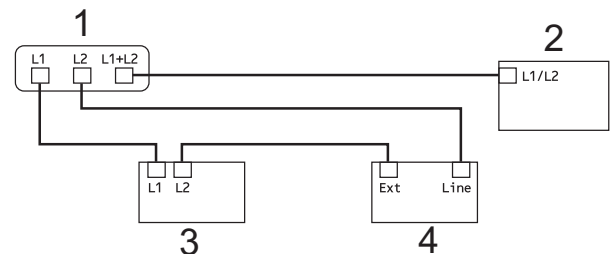

- 1 Triplex Adapter
- 2 Two Line Telephone
- 3 External Two Line TAD
- 4 Machine

Your additional two-line telephones on other wall outlets do not require adapters. There are two ways to add a two-line telephone to the machine's wall outlet. You can plug the telephone line cord from the two-line telephone into the L1+L2 jack of the triplex adapter. Or, you can plug the two-line telephone into the TEL jack of the two-line TAD.

Additional dialing operations

Outgoing Call

The last 30 numbers you sent a fax to will be stored in the outgoing call history. You can choose one of these numbers to fax to, add to Speed Dial, or delete from the history.

- 1 Press **Redial/Pause**.
You can also choose *Outgoing Call* by pressing  (**FAX**).
- 2 Press **▲** or **▼** to choose the number you want.
Press **OK**.
- 3 Do one of the following:
 - To send a fax, press **▲** or **▼** to choose *Send a fax*.
Press **OK**.
Press **Black Start** or **Color Start**.
 - If you want to store the number, press **▲** or **▼** to choose *Add to Speed Dial*.
Press **OK**.
(See *Storing Speed Dial numbers from Outgoing Calls* >> page 20.)
 - If you want to delete the number from the *Outgoing Call* history list, press **▲** or **▼** to choose *Delete*.
Press **OK**.
Press **1** to confirm.
- 4 Press **Stop/Exit**.

Caller ID history

This feature requires the Caller ID subscriber service offered by many local telephone companies. (See *Caller ID* >> page 15.)

The numbers, or names if available, from the last 30 fax and telephone calls you received will be stored in the Caller ID history. You can view the list or choose one of these numbers to fax to, add to Speed Dial, or delete from the history. When the thirty-first call comes into the machine, it replaces information about the first call.



Note

If you are not a Caller ID subscriber, Caller ID history only allows you to view and delete the dates of calls.

- 1 Press **Redial/Pause** and press *****.
You can also choose *Caller ID hist.* by pressing  (**FAX**).
- 2 Press **▲** or **▼** to choose the number you want.
Press **OK**.
- 3 Do one of the following:
 - To send a fax, press **▲** or **▼** to choose *Send a fax*.
Press **OK**.
Press **Black Start** or **Color Start**.
 - If you want to store the number, press **▲** or **▼** to choose *Add to Speed Dial*.
Press **OK**.
(See *Storing Speed Dial numbers from the Caller ID history* >> page 20.)
 - If you want to delete the number from the *Caller ID* history list, press **▲** or **▼** to choose *Delete*.
Press **OK**.
Press **1** to confirm.
- 4 Press **Stop/Exit**.

**Note**

- (USA only) If you redial from the Caller ID history outside your area code, you must set up your AREA CODE in advance. (See *Setting up your area code (USA only)* >> page 16.)
- You can print the Caller ID List. (See *How to print a report* >> page 24.)

Dialing access codes and credit card numbers

Sometimes, you may want to choose from several long distance carriers when you send a fax. Rates may vary depending on the time and destination. To take advantage of low rates, you can store the access codes of long-distance carriers and credit card numbers as Speed Dial numbers. You can store these long dialing sequences by dividing them and setting them up as separate Speed Dial numbers in any combination. You can even include manual dialing using the dial pad. (>>Basic User's Guide: *Storing Speed Dial numbers*)

For example, you might have stored "555" on Speed Dial: 03 and "7000" on Speed Dial: 02. You can use them both to dial "555-7000" if you press the following keys:

- 1 Press (**Speed Dial**).
- 2 Press or to choose *Search*. Press **OK**.
- 3 Enter **03**.
- 4 Press or to choose *Speed Dial*. Press **OK**.
- 5 Press or to choose *Search*. Press **OK**.
- 6 Enter **02**.
- 7 Press **Black Start** or **Color Start**. You will dial "555-7000".

To temporarily change a number, you can substitute part of the number with manual dialing using the dial pad. For example, to change the number to 555-7001 you could press (**Speed Dial**), choose *Search*, press **03** and then press **7001** using the dial pad.

**Note**

If you must wait for another dial tone or signal at any point in the dialing sequence, create a pause in the number by pressing **Redial/Pause**. Each key press adds a 3.5-second delay.

Additional ways to store numbers

Storing Speed Dial numbers from Outgoing Calls

You can also store Speed Dial numbers from the Outgoing Call history.

- 1 Press **Redial/Pause**.
You can also choose *Outgoing Call* by pressing  (**FAX**).
- 2 Press ▲ or ▼ to choose the name or number you want to store.
Press **OK**.
- 3 Press ▲ or ▼ to choose *Add to Speed Dial*.
Press **OK**.
- 4 Press ▲ or ▼ to choose the 2-digit Speed Dial location where you want to store the number.
Press **OK**.
- 5 Do one of the following:
 - Enter the name (up to 16 characters) using the dial pad.
Press **OK**.
(>>>Basic User's Guide: *Entering Text*)
 - To store the number without a name, press **OK**.
- 6 Press **OK** to confirm the fax or telephone number.
- 7 Press ▲ or ▼ to choose *Complete*.
Press **OK**.
- 8 Press **Stop/Exit**.

Storing Speed Dial numbers from the Caller ID history

If you have the Caller ID subscriber service from your telephone company, you can also store Speed Dial numbers from incoming calls in the Caller ID History. (See *Caller ID* >> page 15.)

- 1 Press **Redial/Pause** and press *.
You can also choose *Caller ID hist.* by pressing  (**FAX**).
- 2 Press ▲ or ▼ to choose the number you want to store.
Press **OK**.
- 3 Press ▲ or ▼ to choose *Add to Speed Dial*.
Press **OK**.
- 4 Press ▲ or ▼ to choose the 2-digit Speed Dial location where you want to store the number.
Press **OK**.
- 5 Do one of the following:
 - If you want to store the displayed name, press **OK**.
 - Enter the name (up to 16 characters) using the dial pad.
Press **OK**.
(>>>Basic User's Guide: *Entering Text*)
 - To store the number without a name, press **OK**.
- 6 Press **OK** to confirm the fax or telephone number.
- 7 Press ▲ or ▼ to choose *Complete*.
Press **OK**.
- 8 Press **Stop/Exit**.

Setting up Groups for Broadcasting

Groups, which can be stored on a Speed Dial location, allow you to send the same fax message to many fax numbers by pressing  (**Speed Dial**), *Search*, **OK**, the two-digit location and **Black Start**.

First, you'll need to store each fax number in a Speed Dial location.

(▶▶ Basic User's Guide: *Storing Speed Dial numbers*)

Then you can include them as numbers in the Group. Each Group uses up a Speed Dial location. You can have up to six Groups, or you can assign up to 39 numbers to a large Group.

(See *Broadcasting (Black & White only)* ▶▶ page 11.)

- 1 Press  (**Speed Dial**).
- 2 Press **▲** or **▼** to choose *Setup Groups*. Press **OK**.
- 3 Press **▲** or **▼** to choose *GROUP1*, *GROUP2*, *GROUP3*, *GROUP4*, *GROUP5* or *GROUP6* for the Group name where you will store the fax numbers. Press **OK**.
- 4 Press **▲** or **▼** to choose the 2-digit Speed Dial location where you want to store the Group. Press **OK**.
- 5 If you want to change the Group name, press **▲** or **▼** to choose *Change Group Name* and press **OK**. Then enter the new Group name and press **OK**.
- 6 Press **▲** or **▼** to choose *Add Number*. Press **OK**.

- 7 To add numbers to the Group, press **▲** or **▼** to choose *Alphabetical Order* or *Numerical Order* and press **OK**. Press **▲** or **▼** to select a number and press **OK**.

- 8 Do one of the following:
 - To add another number to the Group, repeat steps 6 to 7.
 - If you are finished adding numbers to the Group, press **▲** or **▼** to choose *Complete*. Press **OK**.

- 9 Do one of the following:
 - To store another Group for broadcasting, repeat steps 3 to 8.
 - To finish storing Groups for broadcasting, press **Stop/Exit**.



Note

You can print a list of all the Speed Dial numbers. Group numbers will be marked in the *GROUP* column. (See *Reports* ▶▶ page 24.)

Changing a Group name

- 1 Press  (**Speed Dial**).
- 2 Press **▲** or **▼** to choose `Setup Groups`. Press **OK**.
- 3 Press **▲** or **▼** to choose the Group name you want to change. Press **OK**.
- 4 Press **▲** or **▼** to choose `Change Group Name`. Press **OK**.



Note

How to change the stored name or number:

If you want to change a character, press **◀** or **▶** to position the cursor under the character you want to change, and then press **Clear**. Re-enter the character.

- 5 Enter the new name (up to 16 characters) using the dial pad. (**>>**Basic User's Guide: *Entering Text*) Press **OK**.
(For example, type NEW CLIENTS.)
- 6 Press **▲** or **▼** to choose `Complete`. Press **OK**.
- 7 Press **Stop/Exit**.

Deleting a Group

- 1 Press  (**Speed Dial**).
- 2 Press **▲** or **▼** to choose `Setup Groups`. Press **OK**.
- 3 Press **▲** or **▼** to choose the Group you want to delete. Press **OK**.
- 4 Press **▲** or **▼** to choose `Delete`. Press **OK**. Press **1** to confirm.
- 5 Press **Stop/Exit**.

Deleting a number from a Group

- 1 Press  (**Speed Dial**).
- 2 Press **▲** or **▼** to choose `Setup Groups`. Press **OK**.
- 3 Press **▲** or **▼** to choose the Group you want to change. Press **OK**.
- 4 Press **▲** or **▼** to choose the number you want to delete. Press **OK**. Press **1** to confirm.
- 5 Press **▲** or **▼** to choose `Complete`. Press **OK**.
- 6 Press **Stop/Exit**.

Fax reports

Use the **Menu** keys to set up the Transmission Verification Report and the Journal Period.

Transmission Verification Report

You can use the Transmission Verification Report as proof that you sent a fax.

(▶▶Basic User's Guide: *Transmission Verification Report*)

Fax Journal (activity report)

You can set the machine to print a journal at specific intervals (every 50 faxes, 6, 12 or 24 hours, 2 or 7 days). If you set the interval to **Off**, you can still print the report by following the steps in *How to print a report* ▶▶ page 24. The factory setting is **Every 50 Faxes**.

- 1 Press **Menu**.
- 2 Press ▲ or ▼ to choose **Fax**. Press **OK**.
- 3 Press ▲ or ▼ to choose **Report Setting**. Press **OK**.
- 4 Press ▲ or ▼ to choose **Journal Period**. Press **OK**.

- 5 Press ▲ or ▼ to choose an interval. Press **OK**.
If you choose **Every 50 Faxes**, go to step 8.

- **6, 12, 24 hours, 2 or 7 days**

The machine will print the report at the chosen time and then erase all jobs from its memory. If the machine's memory becomes full with 200 jobs before the time you chose has passed, the machine will print the Journal early and then erase all jobs from the memory. If you want an extra report before it is due to print, you can print it without erasing the jobs from the memory.

- **Every 50 Faxes**

The machine will print the Journal when the machine has stored 50 jobs.

- 6 Enter the time to start printing in 24-hour format. Press **OK**.
(For example: enter 19:45 for 7:45 PM.)



Note

When you set **12h Clock** in the **Date&Time setting** in **Initial Setup**, enter the time in 12-hour format.

- 7 If you chose **Every 7 Days** in step 5, press ▲ or ▼ to display the days of the week. Then choose the day you want to be the first day of the 7-day countdown. Press **OK**.
- 8 Press **Stop/Exit**.

Reports

The following reports are available:

- **Transmission**
Prints a Transmission Verification Report for your last transmission.
- **Quick Dial**
Lists names and numbers stored in the Speed Dial memory, in alphabetical or numerical order.
- **Fax Journal**
Lists information about the last incoming and outgoing faxes.
(TX: Transmit.) (RX: Receive.)
- **User Settings**
Lists your settings.
- **Network Config**
Lists your Network settings.
- **WLAN Report**
Prints the result of the WLAN connection.
- **Caller ID hist.**
Lists the available Caller ID information about the last 30 received faxes and telephone calls.

How to print a report

- 1 Press **Menu**.
- 2 Press **▲** or **▼** to choose **Print Reports**.
Press **OK**.
- 3 Press **▲** or **▼** to choose the report you want.
Press **OK**.
- 4 (Quick Dial Only) Press **▲** or **▼** to choose **Alphabetical Order** or **Numerical Order**.
Press **OK**.
- 5 Press **Black Start**.
- 6 Press **Stop/Exit**.

Copy settings

You can change the copy settings temporarily for the next copy.

These settings are temporary. The machine returns to its default settings 1 minute after copying unless you have set the Mode Timer to 30 seconds or less. (See *Mode Timer* >> page 5.)

To change a setting, press **COPY** and then press ▲ or ▼ to scroll through the copy settings. When the setting you want is highlighted, press **OK**.

When you are finished choosing settings, press **Black Start** or **Color Start**.



Note

You can save some of the settings that you use most often by setting them as default. These settings will stay until you change them again. (See *Setting your changes as the new default* >> page 29.)

Stop copying

To stop copying, press **Stop/Exit**.

Changing copy quality

You can choose from a range of quality. The factory setting is **Normal**.

■ Fast

Fast copy speed and lowest amount of ink used. Use to save time printing documents to be proof-read, large documents or many copies.

■ Normal

Normal is the recommended mode for ordinary printouts. This produces good copy quality with good copy speed.

■ Best

Use Best mode to copy precise images such as photographs. This provides the highest resolution and slowest speed.

- 1 Press  (**COPY**).
- 2 Load your document.
- 3 Enter the number of copies you want.
- 4 Press ▲ or ▼ to choose **Quality**. Press **OK**.
- 5 Press ▲ or ▼ to choose **Fast**, **Normal** or **Best**. Press **OK**.
- 6 If you do not want to change additional settings, press **Black Start** or **Color Start**.

Enlarging or reducing the copied image

You can choose an enlargement or reduction ratio. If you choose **Fit to Page**, your machine will adjust the size automatically to the paper size you set.

- 1 Press  (**COPY**).
- 2 Load your document.
- 3 Enter the number of copies you want.
- 4 Press ▲ or ▼ to choose **Enlarge/Reduce**. Press **OK**.
- 5 Press ▲ or ▼ to choose **100%**, **Enlarge**, **Reduce**, **Fit to Page** or **Custom (25-400%)**.
- 6 Do one of the following:
 - If you chose **Enlarge** or **Reduce**, press **OK** and press ▲ or ▼ to choose the enlargement or reduction ratio you want. Press **OK**.
 - If you chose **Custom (25-400%)**, press **OK** and then enter an enlargement or reduction ratio from 25% to 400%. Press **OK**.
 - If you chose **100%** or **Fit to Page**, press **OK**. Go to step 7.

198% 4"x6"→A4
186% 4"x6"→LTR
104% EXE→LTR
100%
97% LTR→A4
93% A4→LTR
85% LTR→EXE
83% LGL→A4
78% LGL→LTR
46% LTR→4"x6"
Fit to Page
Custom (25-400%)

- 7 If you do not want to change additional settings, press **Black Start** or **Color Start**.



Note

- Page Layout is not available with Enlarge/Reduce.
- Page Layout and Sort are not available with Fit to Page.
- Fit to Page does not work properly when the document on the scanner glass is skewed more than 3 degrees. Using the document guidelines on the left and top, place your document in the upper left hand corner, with the document face down on the scanner glass.
- Fit to Page is not available when using the ADF.

Making N in 1 copies or a poster (Page Layout)

The N in 1 copy feature can help you save paper by letting you copy two or four pages onto one printed page.

You can also produce a poster. When you use the poster feature your machine divides your document into sections, then enlarges the sections so you can assemble them into a poster. If you want to print a poster, use the scanner glass.

! IMPORTANT

- Make sure the paper size is set to Letter, A4 or Executive.
- Poster copy is not available for Executive size paper.
- If you are producing multiple color copies, N in 1 copy is not available.
- (P) means Portrait and (L) means Landscape.
- Poster copy is not available when using transparencies.



Note

Sort and Enlarge/Reduce are not available with Page Layout.

- 1 Press  (**COPY**).
- 2 Load your document.
- 3 Enter the number of copies you want.
- 4 Press ▲ or ▼ to choose Page Layout. Press **OK**.

- 5 Press ▲ or ▼ to choose Off (1in1), 2in1 (P), 2in1 (L), 4in1 (P), 4in1 (L), Poster (2x1), Poster (2x2), Poster (3x3) or 2in1 (ID)¹. Press **OK**.

¹ For details about 2 in 1 (ID), see *2 in 1 ID Copy* >> page 28.

- 6 If you do not want to change additional settings, press **Black Start** or **Color Start** to scan the page. If you placed the document in the ADF or are making a poster, the machine scans the pages and starts printing.

If you are using the scanner glass, go to step 7.

- 7 After the machine scans the page, press **1** to scan the next page.
- 8 Place the next page on the scanner glass. Press **OK**.
- 9 Repeat steps 7 and 8 for each page of the layout.
- 10 After all the pages have been scanned, press **2** to finish.

Place the document face down in the direction shown below:

■ 2in1 (P)



■ 2in1 (L)



■ 4in1 (P)



■ 4in1 (L)



■ Poster (2x1)

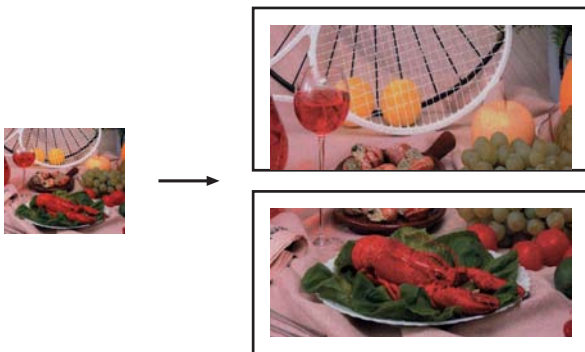

■ Poster (2x2)

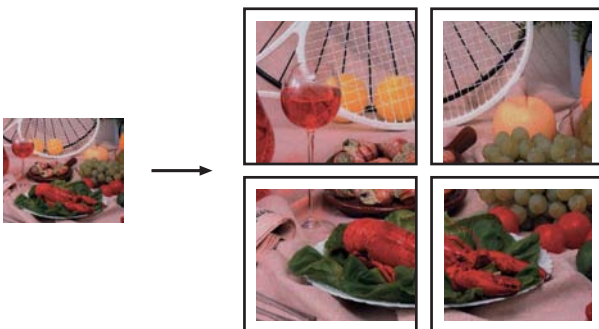

■ Poster (3x3)

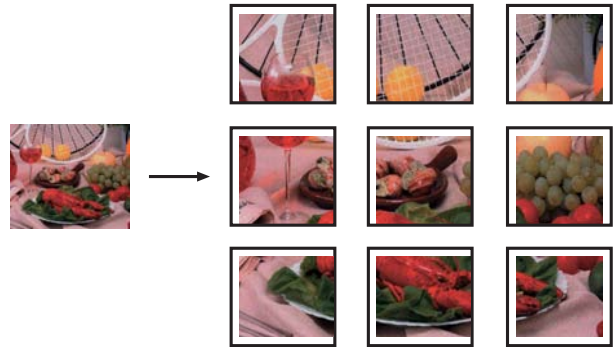

2 in 1 ID Copy

You can copy both sides of your identification card onto one page, keeping the original card size. Make sure the paper size is set to Letter or A4.

Note

You can copy an identification card to the extent permitted under applicable laws. (▶▶Product Safety Guide: *Legal limitations for copying*)

- 1 Press (COPY).
- 2 Place your identification card face down at the left corner of the scanner glass.

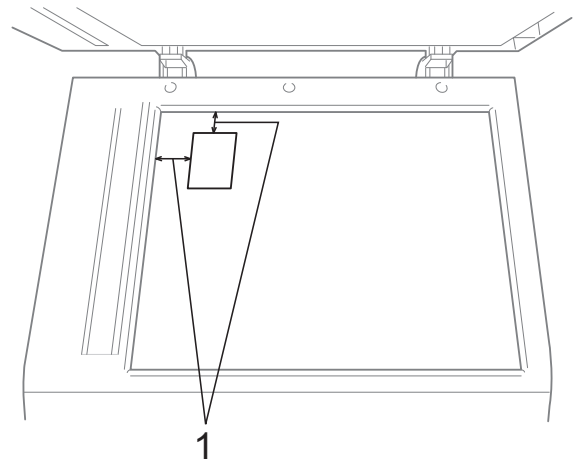

1 0.12 in. (3 mm) or greater (top, left)

- 3 Enter the number of copies you want.

- 4 Press ▲ or ▼ to choose *Page Layout*. Press **OK**.
- 5 Press ▲ or ▼ to choose *2in1 (ID)*. Press **OK**.
- 6 Press **Black Start** or **Color Start**. The machine starts scanning the first page.
- 7 After the machine has scanned one side, press **1**. Turn over the identification card and press **OK** to scan the other side.



Note

- *Sort* and *Enlarge/Reduce* are not available with *2in1 (ID)*.
- If you are producing multiple color copies, *2 in 1 (ID)* copy is not available.

Sorting copies using the ADF

You can sort multiple copies. Pages will be stacked in the order 321, 321, 321, and so on.

- 1 Press  (**COPY**).
- 2 Load your document.
- 3 Enter the number of copies you want.
- 4 Press ▲ or ▼ to choose *Stack/Sort*. Press **OK**.
- 5 Press ▲ or ▼ to choose *Sort*. Press **OK**.
- 6 If you do not want to change additional settings, press **Black Start** or **Color Start**.



Note

Fit to Page and *Page Layout* are not available with *Sort*.

Adjusting Density

You can adjust the copy density to make copies darker or lighter.

- 1 Press  (**COPY**).
- 2 Load your document.
- 3 Enter the number of copies you want.
- 4 Press ▲ or ▼ to choose *Density*. Press **OK**.
- 5 Press ► to make the copy darker or press ◀ to make the copy lighter. Press **OK**.
- 6 If you do not want to change additional settings, press **Black Start** or **Color Start**.

Setting your changes as the new default

You can save the settings for the copy options you use most often by setting them as the default, such as *Quality*, *Enlarge/Reduce*, *Density* and *Page Layout*. These settings will stay until you change them again.

- 1 Press  (**COPY**).
- 2 Press ▲ or ▼ to choose your new setting. Press **OK**. Repeat this step for each setting you want to change.
- 3 After changing the last setting, press ▲ or ▼ to choose *Set New Default*. Press **OK**.
- 4 Press **1** to choose *Yes*.
- 5 Press **Stop/Exit**.

Restoring all settings to the factory settings

You can restore the copy settings that you have changed to the factory settings, such as Quality, Enlarge/Reduce, Density, and Page Layout.

- 1 Press  (**COPY**).
- 2 Press ▲ or ▼ to choose Factory Reset.
Press **OK**.
- 3 Press **1** to choose Yes.
- 4 Press **Stop/Exit**.

A

Routine maintenance

Cleaning and checking the machine

Cleaning the outside of the machine

Clean the outside of the machine as follows:

! IMPORTANT

- Use neutral detergents. Cleaning with volatile liquids such as thinner or benzine will damage the outside surface of the machine.
- DO NOT use cleaning materials that contain ammonia.
- DO NOT use isopropyl alcohol to remove dirt from the control panel. It may crack the panel.

- 1 Pull the paper tray (1) completely out of the machine.

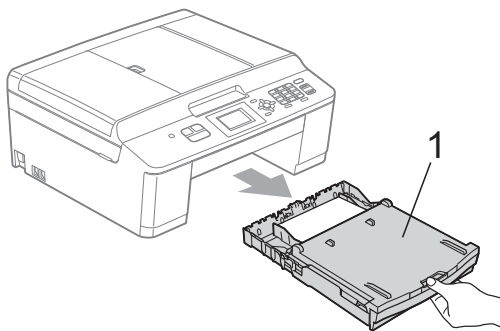

- 2 Wipe the outside of the machine with a *dry*, soft lint-free cloth to remove dust.

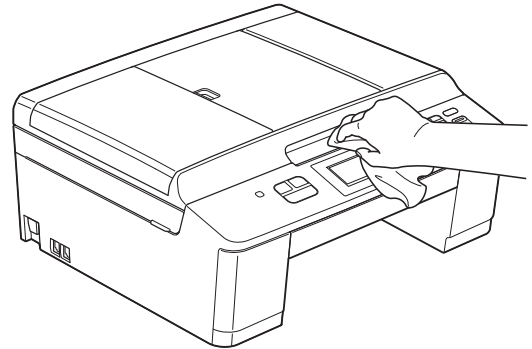

- 3 Lift the output paper tray cover and remove anything that is stuck inside the paper tray.
- 4 Wipe the inside and outside of the paper tray with a *dry*, soft lint-free cloth to remove dust.

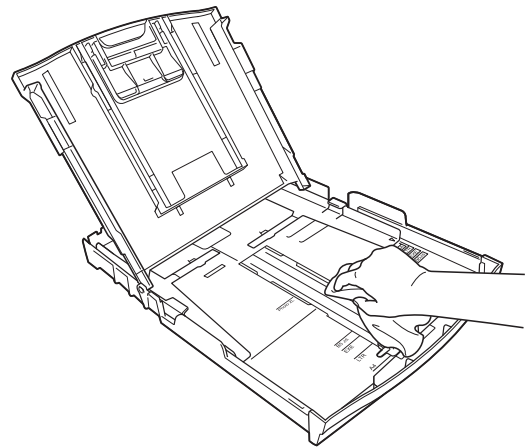

- 5 Close the output paper tray cover and put the paper tray firmly back in the machine.

A

Cleaning the machine's printer platen

WARNING



Be sure to unplug the machine from the AC power outlet before cleaning the printer platen to avoid an electrical shock.

- 1 Using both hands, grasp the plastic tabs on both side of the machine to lift the scanner cover into the open position.
- 2 Clean the machine's printer platen (1) and the area around it, wiping off any scattered ink with a *dry*, soft lint-free cloth.

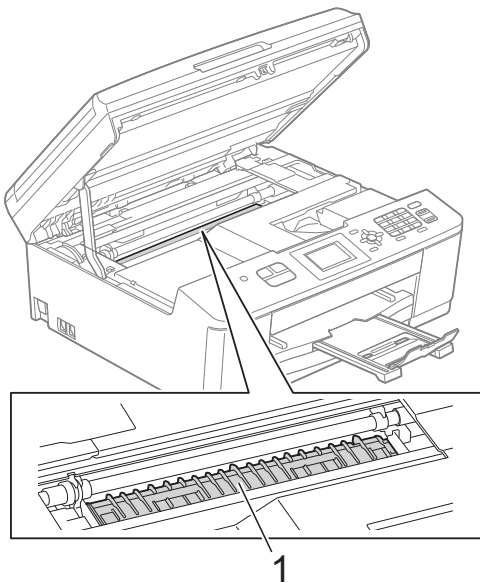

- 3 Using both hands, grasp the plastic tabs on both sides of the machine and gently close the scanner cover.
- 4 Re-connect the power cord.

Cleaning the paper pick-up rollers

- 1 Unplug the machine from the AC power outlet.
- 2 Pull the paper tray completely out of the machine.



Note

If the machine starts to multi-feed the last few sheets of paper in the tray, clean the Base Pad (1) with a soft lint-free cloth moistened with water.

After cleaning, wipe the pad with a *dry*, soft lint-free cloth to remove all moisture.

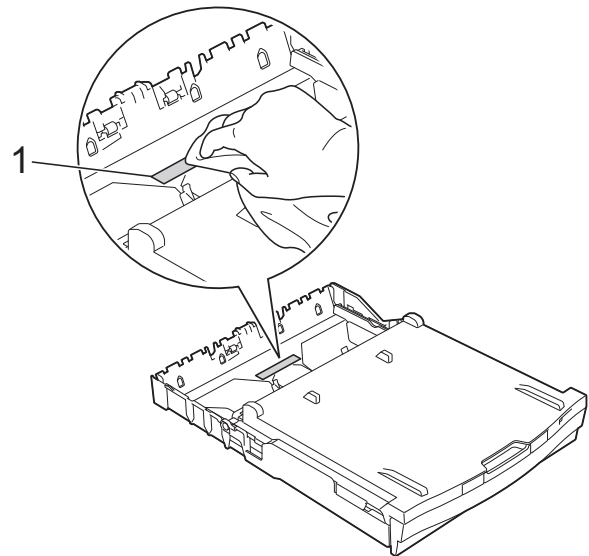

- 3 Open the Jam Clear Cover (1) at the back of the machine.

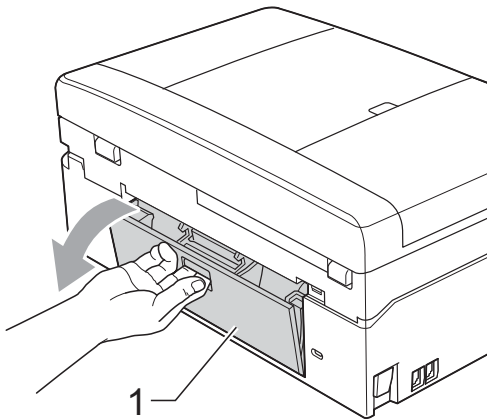

- 4 Clean the Paper Pick-up Rollers (1) with a soft lint-free cloth moistened with water. Slowly turn the rollers so that the whole surface is cleaned. After cleaning, wipe the rollers with a *dry*, soft lint-free cloth to remove all moisture.

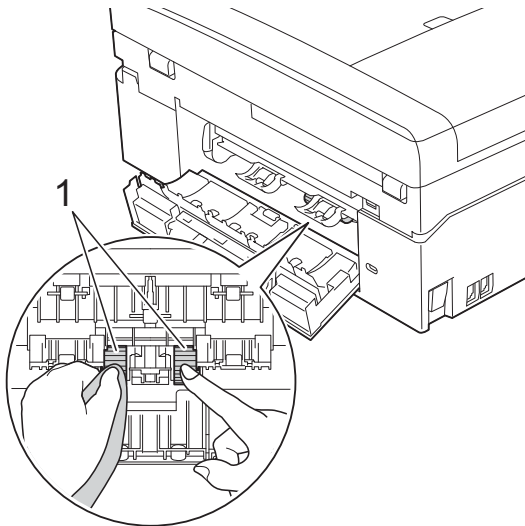

- 5 Close the Jam Clear Cover. Make sure the cover is closed completely.
- 6 Put the paper tray firmly back in the machine.
- 7 Re-connect the power cord.

Checking the ink volume

Although an ink volume icon appears on the LCD, you can use the **Menu** key to see a large graph showing the ink that is left in each cartridge.

- 1 Press **Menu**.
- 2 Press **▲** or **▼** to choose **Ink**. Press **OK**.
- 3 Press **▲** or **▼** to choose **Ink Volume**. Press **OK**. The LCD shows the ink volume.
- 4 Press **Stop/Exit**.



Note

You can check the ink volume from your computer.

➤➤ Software User's Guide: *Printing* (Windows®)

➤➤ Software User's Guide: *Printing and Faxing* (Macintosh)

Packing and shipping the machine

When you transport the machine, use the packing materials that came with your machine. If you do not pack the machine properly, any damage that may occur in transit may not be covered by your warranty.

! IMPORTANT

It is important to allow the machine to “park” the print head after a print job. Listen carefully to the machine before unplugging it to make sure that all mechanical noise has stopped. Not allowing the machine to finish this parking process may lead to print problems and possible damage to the print head.

- 1 Open the ink cartridge cover.
- 2 Press the ink release levers to release the ink cartridges and then take out the ink cartridges. (►►Basic User’s Guide: *Replacing the ink cartridges*)
- 3 Install the orange protective part and then close the ink cartridge cover.

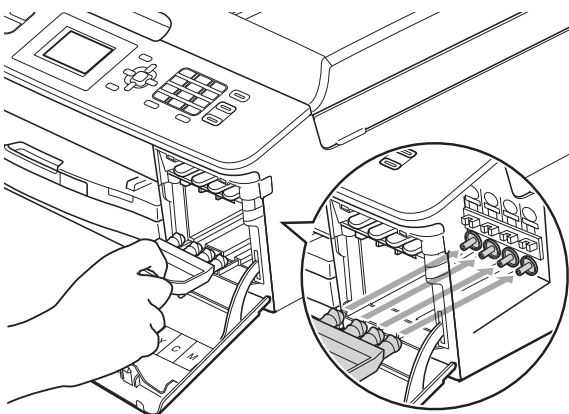

! IMPORTANT

- Make sure the plastic tab on the right side of the orange protective part (1) clicks securely into place (2).

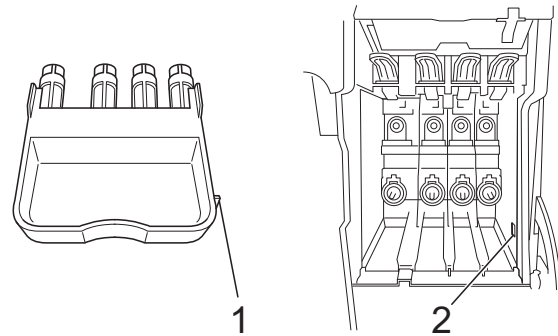

- If you are not able to find the orange protective part, ship the machine without it. DO NOT install the ink cartridges as an alternative before shipping.

- 4 Lift the machine from the front and hook the tab of the orange protective part into the keyed opening (1) on the bottom of the paper tray. Then latch the protective part over the raised portion of the paper tray (2).

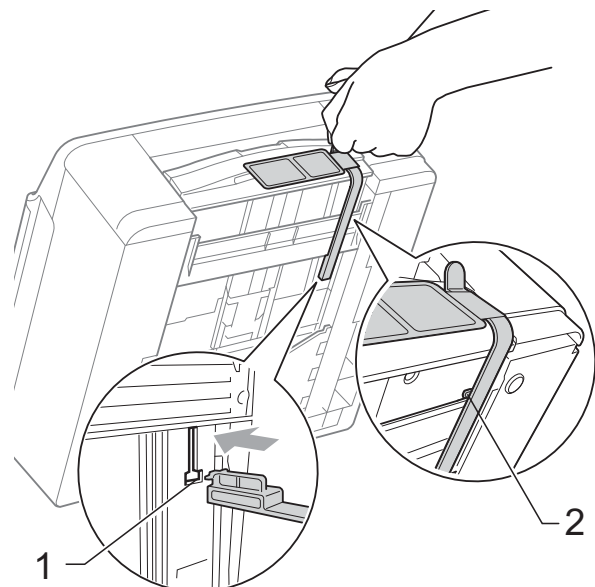

- 5 Unplug the machine from the telephone wall jack and take the telephone line cord out of the machine.
- 6 Unplug the machine from the AC power outlet.
- 7 Using both hands, use the plastic tabs on both sides of the machine to lift the scanner cover into the open position. Then unplug the interface cable from the machine, if it is connected.
- 8 Using both hands, grasp the plastic tabs on both sides of the machine and gently close the scanner cover.

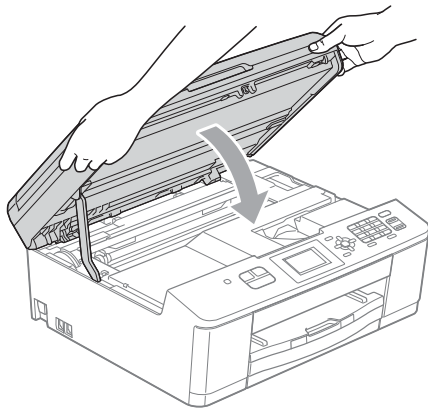

- 9 Wrap the ink cartridges in the bag, then tape the bag on to the paper tray.

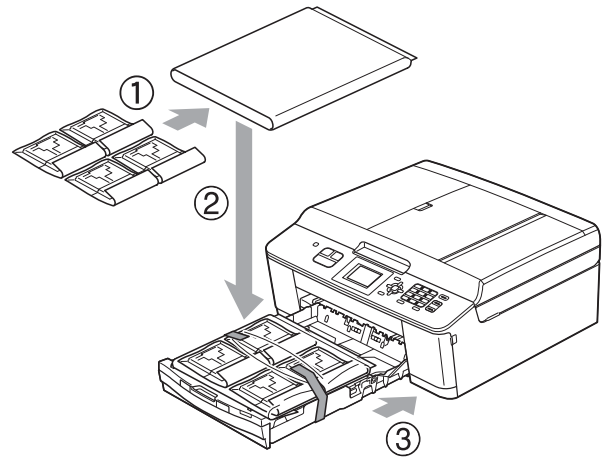

- 10 Wrap the machine in the bag.

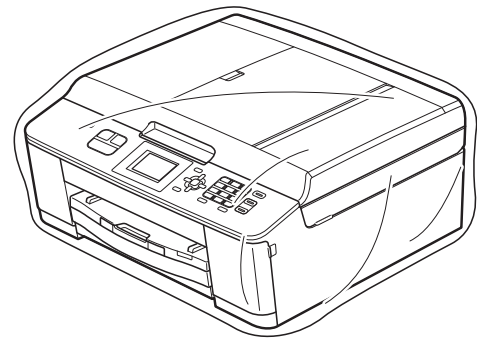

- 11 Pack the machine and the printed materials in the original carton with the original packing material as shown below.



Note

If you are returning your machine to Brother as part of the Exchange Service, pack *only* the machine. Keep all separate parts and printed materials to use with your “Exchange” machine.

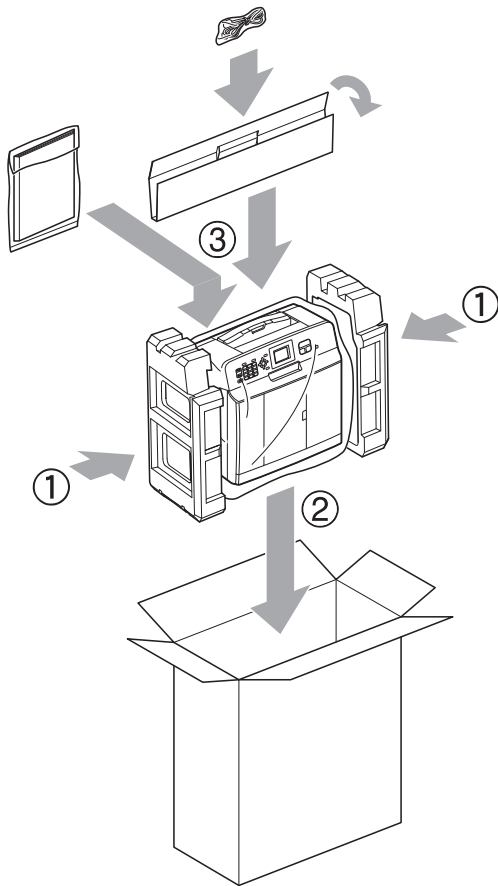

- 12 Close the carton and tape it shut.

B

Glossary

This is a comprehensive list of features and terms that appear in Brother manuals. Availability of these features depends on the model you purchased.

ADF (automatic document feeder)

The document can be placed in the ADF and scanned one page at a time automatically.

Auto Reduction

Reduces the size of incoming faxes.

Automatic Redial

A feature that enables your machine to redial the last fax number after five minutes if the fax did not go through because the line was busy.

Beeper Volume

Volume setting for the beep when you press a key or make an error.

Brightness

Changing the Brightness makes the whole image lighter or darker.

Broadcasting

The ability to send the same fax message to more than one location.

Caller ID

A service purchased from the telephone company that lets you see the number (or name) of the party calling you.

CNG tones

The special tones (beeps) sent by fax machines during automatic transmission to tell the receiving machine that a fax machine is calling.

Coding method

Method of coding the information contained in the document. All fax machines must use a minimum standard of Modified Huffman (MH). Your machine is capable of greater compression methods, Modified Read (MR), Modified Modified Read (MMR) and JPEG, if the receiving machine has the same capability.

Communication error (Comm. Error)

An error during fax sending or receiving, usually caused by line noise or static.

Compatibility group

The ability of one fax unit to communicate with another. Compatibility is assured between ITU-T Groups.

Contrast

Setting to compensate for dark or light documents, by making faxes or copies of dark documents lighter and light documents darker.

Density

Changing the Density makes the whole image lighter or darker.

Distinctive Ring

A subscriber service purchased from the telephone company that gives you another telephone number on an existing telephone line. The Brother machine uses the new number to simulate a dedicated fax line.

Dual Access

Your machine can scan outgoing faxes or scheduled jobs into memory at the same time it is sending a fax from memory or receiving or printing an incoming fax.

Easy Receive

Enables your machine to respond to CNG tones if you interrupt a fax call by answering it.

ECM (Error Correction Mode)

Detects errors during fax transmission and resends the pages of the fax that had an error.

Extension telephone

A telephone using the same line as your fax but plugged into a separate wall jack.

External telephone

A telephone that is plugged into the EXT. jack of your machine.

F/T Ring Time

The length of time that the Brother machine rings (when the Receive Mode setting is Fax/Tel) to notify you to pick up a voice call that it answered.

Fax Journal

Lists information about the last 200 incoming and outgoing faxes. TX means Transmit. RX means Receive.

Fax Receive Code

Press this code (* 5 1) when you answer a fax call on an extension or external telephone.

Fax tones

The signals sent by sending and receiving fax machines while communicating information.

Fax/Tel

You can receive faxes and telephone calls. Do not use this mode if you are using a telephone answering device (TAD).

Fine resolution

Resolution is 203 × 196 dpi. It is used for small print and graphs.

Gray Scale

The shades of gray available for copying, scanning and faxing photographs.

Group number

A combination of Speed Dial numbers that are stored in a Speed Dial location for Broadcasting.

Innobella™

Innobella™ is a range of genuine consumables offered by Brother. For best quality results Brother recommends Innobella™ Ink and Paper.

Journal Period

The pre-programmed time period between automatically printed Fax Journal Reports. You can print the Fax Journal on demand without interrupting the cycle.

LCD (Liquid Crystal Display)

The LCD screen on the machine that shows interactive messages during On-Screen Programming and shows the date and time when the machine is idle.

Manual fax

You can press **Hook** to hear the receiving fax machine answer before you press **Black Start** or **Color Start** to begin sending.

Menu mode

Programming mode for changing your machine's settings.

OCR (optical character recognition)

ScanSoft™ PaperPort™ 12SE with OCR or Presto! PageManager software application converts an image of text to text you can edit.

Overseas Mode

Makes temporary changes to the fax tones to accommodate noise and static on overseas telephone lines.

Pause

Allows you to place a 3.5 second delay in the dialing sequence while you are dialing using the dial pad or while you are storing Speed Dial numbers. Press the **Redial/Pause** key on the control panel as many times as needed for longer pauses.

Photo resolution (B&W only)

A resolution setting that uses varying shades of gray for the best representation of photographs.

Pulse (Canada only)

A form of rotary dialing on a telephone line.

Quick Dial List

A listing of names and numbers stored in Speed Dial memory, in numerical order.

Real Time Transmission

When memory is full, you can send faxes in real time.

Remaining jobs

You can check which jobs are waiting in memory and cancel jobs individually.

Resolution

The number of vertical and horizontal lines per inch. See: Standard, Fine, Super Fine and Photo.

Ring Delay

The number of rings before the machine answers in *Fax Only* and *Fax/Tel* modes.

Ring Volume

Volume setting for the machine's ring.

Scanning

The process of sending an electronic image of a paper document into your computer.

Search

A numerical or alphabetical electronic listing of stored Speed Dial and Group numbers.

Speed Dial

A pre-programmed number for easy dialing.

Standard resolution

203 × 98 dpi (black & white).
203 × 196 dpi (color). It is used for regular sized text and the quickest transmission.

Station ID

The stored information that appears on the top of faxed pages. It includes the sender's name and fax number.

Super Fine resolution (B&W)

203 × 392 dpi. Best for very small print and line art.

TAD (telephone answering device)

You can connect an external telephone answering device or answering machine to the EXT. jack of your machine.

Telephone Answer Code (For Fax/Tel mode only)

When the machine answers a voice call, it pseudo/double-rings. You can pick up at an extension telephone by pressing this code (**# 5 1**).

Temporary settings

You can choose certain options for each fax transmission and copy without changing the default settings.

Tone

A form of dialing on the telephone line used for touch-tone telephones.

Transmission

The process of sending faxes over the phone lines from your machine to the receiving fax machine.

Transmission Verification Report

A listing for the last fax sent, that shows its date, time and number.

User Settings

A printed report that shows the current settings of the machine.

WLAN Report

A printed report that shows the result of the WLAN Connection.

C

Index

Numerics

2 in 1 ID Copy28

A

Access codes, storing and dialing 19

Apple Macintosh
See Software User's Guide.

B

Broadcasting 11
setting up Groups for21

C

Caller ID 15

Caller ID history 18

Add to Speed Dial 18

Delete 18

Send a fax 18

Caller ID History report24

Setting up your area code 16

Canceling
jobs awaiting redial 13

Cleaning
paper pick-up rollers32
printer platen32

Connecting
two-line external TAD or telephone 17

ControlCenter
See Software User's Guide.

Copy

2 in 1 ID28

density29

enlarge/reduce26

page layout (N in 1)27

poster27

quality25

set new default29

sort29

using ADF29

D

Dialing

access codes and credit card

numbers 19

Caller ID history 18

Groups (Broadcasting) 11

Outgoing Call 18

Dual Access 10

F

Fax, from PC
See Software User's Guide.

Fax, stand-alone
receiving

at end of conversation 14

into the memory 14

out of paper reception 14

reducing to fit on paper 14

sending 8

at end of conversation 10

Broadcasting 11

canceling from memory 13

contrast 8

from memory (Dual Access) 10

manual 10

overseas 13

Real Time Transmission 12

Resolution 9

return to factory setting 9

set new default 9

G

Groups for Broadcasting 21

I

ID Copy 28

Ink cartridges
checking ink volume 33

J

Jacks	
Convert to RJ11 jack triplex adapter	17
EXT	
TAD	17

L

LCD Brightness	4
LCD Contrast	4
LCD Dim Timer	4

M

Macintosh	
See Software User's Guide.	
Manual	
transmission	10
Memory Storage	1
Mode, entering	
Timer	5

N

Network	
Printing	
See Network User's Guide.	
Scanning	
See Software User's Guide.	

O

Outgoing Call	
Add to Speed Dial	18
Delete	18
Send a fax	18

P

Packing and shipping the machine	34
PaperPort™ 12SE with OCR	
See Software User's Guide. See also Help in the PaperPort™ 12SE application.	
Power failure	1
Presto! PageManager	
See Software User's Guide. See also Help in the Presto! PageManager application.	
Print	
report	24
Printing	
See Software User's Guide.	

Q

Quick Dial	
Access codes and credit card numbers	19
Broadcasting	11
deleting Groups	22
using Groups	11
Group dial	
changing	22
setting up Groups for Broadcasting	21
Speed Dial	
setting up from Caller ID history	20
setting up from outgoing calls	20

R

Reducing	
copies	26
incoming faxes	14
Reports	23
Caller ID History Report	24
Fax Journal	24
Journal Period	23
how to print	24
Network Configuration	24
Quick Dial List	24
Transmission Verification	23, 24
User Settings	24
WLAN Report	24
Resolution	
setting for next fax	9

S

- Scanning
 - See Software User's Guide.
- Shipping the machine34
- Sleep Mode3
- Speed Dial
 - setting up from Caller ID history20
 - setting up from outgoing calls20

T

- TAD (telephone answering device),
 - external17
 - with two-line jack17
- Telephone line
 - roll over lines16
 - two-line telephone system16
- Troubleshooting
 - checking ink volume33
- Two-line telephone system16
- TX Lock
 - turning on/off7

V

- Volume, setting
 - beeper2
 - ring1
 - speaker2

W

- Warranties are in the box
- Windows®
 - See Software User's Guide.
- Wireless Network
 - See Quick Setup Guide and Network User's Guide.

Brother International Corporation
100 Somerset Corporate Boulevard
P.O. Box 6911
Bridgewater, NJ 08807-0911 USA

Brother International Corporation (Canada) Ltd.
1 rue Hôtel de Ville,
Dollard-des-Ormeaux, QC, Canada H9B 3H6

brother®

Visit us on the World Wide Web
<http://www.brother.com/>

These machines are approved for use in the country of purchase only. Local Brother companies or their dealers will only support machines purchased in their own countries.