

HP StorageWorks

Brocade 4Gb SAN Switch for HP c-Class BladeSystem

user guide



* A A - R W E B B - T E *

Part number: AA-RWEBB-TE
First edition: September 2007



Legal and notice information

© Copyright 2007 Hewlett-Packard Development Company, L.P.

© Copyright 2007 Brocade Communications Systems, Incorporated

The information contained herein is subject to change without notice. The only warranties for HP products and services are set forth in the express warranty statements accompanying such products and services. Nothing herein should be construed as constituting an additional warranty. HP shall not be liable for technical or editorial errors or omissions contained herein.

Microsoft, Windows, and Windows XP are U.S. registered trademarks of Microsoft Corporation.

UNIX is a registered trademark of The Open Group.

Contents

About this guide	9
Intended audience	9
SAN Switch related documentation	9
HP c-Class BladeSystem related documentation	9
Before you contact HP Technical Support	10
HP contact information	10
Document conventions and symbols	11
Subscription service	12
Other HP web sites	12
1 Overview	13
4Gb SAN Switch features	14
Component identification	15
Port side of the 4Gb SAN Switch	16
Internal ports summary	16
4Gb SAN Switch redundancy	17
4Gb SAN Switch licensing	18
ISL trunking groups	19
Supported optional features	19
Optional hardware kits	20
2 Setup	21
Shipping carton contents	21
Installation and safety considerations	22
Installing multiple switches	22
Electrical considerations	23
Environmental considerations	23
Install the 4Gb SAN Switch	24
OA verifies power	26
Checking LEDs	27
Setting the IP address	28
Using Enclosure Bay IP Addressing (EBIPA)	28
Using External DHCP	29
Setting the IP address manually	29
Configure the 4Gb SAN Switch	31
Items required for configuration	31
Connecting to the Command Line Interface	32

Setting the date and time	33
Verifying installed licenses	34
Modifying the FC domain ID (optional)	35
Disabling and enabling a switch	36
Disabling and enabling a port	36
Using Dynamic Ports On Demand (DPOD)	37
DPOD commands	37
Verifying the configuration	39
Backing up the configuration	39

3 Managing the 4Gb SAN Switch 41

Management features	41
Maintaining the 4Gb SAN Switch	43
Installing dust covers in empty ports	43
Replacing an SFP transceiver	43
Diagnostic tests	44
Powering on and off	45
Interpreting LED activity	45
LED indicators	46
LED patterns	47
Module status LED patterns	47
Port link status LED patterns	48
Port link speed LED patterns	49
POST and boot specifications	49
POST	49
Boot	49
Interpreting POST results	50
Firmware update	51
About the reset button	52
Rebooting the switch	52
Replacing a faulty 4Gb SAN Switch	53

A Regulatory compliance and safety 55

Regulatory compliance	55
Federal Communications Commission notice for Class A equipment	55
Declaration of conformity for products marked with the FCC logo, United States only	55
Modifications	56
Cables	56
Regulatory compliance identification numbers	56
Laser device	56
Laser safety warning	56
Certification and classification information	57
Laser product label	57
International notices and statements	57
Canadian notice (avis Canadien)	57

Class A equipment	57
European Union notice	58
BSMI notice	58
Japanese notice	59
Korean notices	59
Safety	60
Battery replacement notice	60
Taiwan battery recycling notice	61
Power cords	61
Japanese power cord statement	61
Waste Electrical and Electronic Equipment directive	62
English notice	62
Dutch notice	62
Czechoslovakian notice	63
Estonian notice	63
Finnish notice	64
French notice	64
German notice	65
Greek notice	65
Hungarian notice	66
Italian notice	66
Latvian notice	67
Lithuanian notice	67
Polish notice	68
Portuguese notice	68
Slovakian notice	69
Slovenian notice	69
Spanish notice	70
Swedish notice	70
B Electrostatic discharge	71
How to prevent electrostatic discharge	71
Grounding methods	71
C SAN Switch technical specifications	73
General specifications	74
Weight and physical dimensions	75
Environmental requirements	76
Supported SFPs	76
Supported HBAs	76
Glossary	77
Index	87

Figures

1	Identifying components	15
2	4Gb SAN Switch external ports	16
3	Carton contents	22
4	Releasing the installation handle	25
5	Installing the Brocade 4Gb SAN Switch into an interconnect bay	26
6	Verifying power-on LEDs	27
7	Installing an SFP	44
8	Identifying LEDs	46
9	Locating the Reset button	52
10	Class 1 laser product label	57

Tables

1	Document conventions	11
2	Brocade 4Gb SAN Switch components	25
3	Identifying 4Gb SAN Switch external ports	16
4	Optional hardware	20
5	Brocade 4Gb SAN Switch components	22
6	Release mechanism components	25
7	Power-on LEDs	27
8	4Gb SAN Switch management features	42
9	Connecting via a management station	43
10	SFP components	44
11	Front panel LED indicators during normal operation	46
12	Module Status LED patterns during normal operation	47
13	Port link status LED patterns	48
14	Locating the reset button	52
15	General specifications	74
16	4Gb SAN Switch physical dimensions	75
17	Environmental requirements	76

About this guide

This guide provides information about setting up and configuring the Brocade 4Gb SAN Switch for HP c-Class BladeSystem. Throughout this guide the short product name is used, 4Gb SAN Switch.

Intended audience

This guide is intended for system administrators and technicians with knowledge of:

- Configuration aspects of customer Storage Area Network (SAN) fabric
- Customer host environment, such as Microsoft® Windows® or Linux®
- Command Line Interface (CLI) commands
- Advanced Web Tools Graphical User Interface (GUI) for configuring the switches through a supported web browser

SAN Switch related documentation

SAN Switch-related documents and other SAN infrastructure documentation, including white papers and best practices documents, are available at:

<http://www.hp.com/support/manuals>

Scroll to the **storage** section of the web page and select **Storage Networking** for HP StorageWorks products.



IMPORTANT:

For late breaking, supplemental information, access the latest version of the *HP StorageWorks Fabric OS release notes* for the 4Gb SAN switch.

HP c-Class BladeSystem related documentation

HP c-Class BladeSystem enclosure user documentation, including white papers and best practices documents, are available at:

- <http://www.hp.com/go/bladesystem/documentation>

Before you contact HP Technical Support

Be sure to have the following information available before you call HP:

- Technical support registration number (if applicable)
- Product serial number
- Product model name and number
- Applicable error messages
- Third-party hardware or software
- Operating system type and revision level

For continuous quality improvement, calls may be recorded or monitored.

HP contact information

For the name of the nearest HP authorized reseller:

- In the United States, see the HP US service locator web page:
http://www.hp.com/service_locator
- In other locations, see the Contact HP worldwide (in English) web page:
<http://welcome.hp.com/country/us/en/wwcontact.html>
- In the United States, for contact options see the Contact HP United States web page:
http://welcome.hp.com/country/us/en/contact_us.html
- Call 1-800-HP-INVENT (1-800-474-6836). This service is available 24 hours a day, 7 days a week. For continuous quality improvement, calls may be recorded or monitored.
- If you have purchased a Care Pack (service upgrade), call 1-800-633-3600. For more information about Care Packs, refer to the HP web site:
<http://www.hp.com>

Document conventions and symbols

Table 1 Document conventions

Convention	Element
Blue text: Table 1	Cross-reference links and e-mail addresses
Blue, underlined text: http://www.hp.com	Web site addresses
Bold text	<ul style="list-style-type: none">• Keys that are pressed• Text typed into a GUI element, such as a box• GUI elements that are clicked or selected, such as menu and list items, buttons, tabs, or check boxes
<i>Italic</i> text	Text emphasis
Monospace text	<ul style="list-style-type: none">• File and directory names• System output• Code• Commands, their arguments, and argument values
<i>Monospace, italic</i> text	<ul style="list-style-type: none">• Code variables• Command variables
Monospace, bold text	Emphasized monospace text

 **WARNING!**

Indicates that failure to follow directions could result in bodily harm or death.

 **CAUTION:**

Indicates that failure to follow directions could result in damage to equipment or data.

 **IMPORTANT:**

Provides clarifying information or specific instructions.



NOTE:

Provides additional information.



TIP:

Provides helpful hints and shortcuts.

Subscription service

HP strongly recommends that customers register online using the Subscriber's choice web site: <http://www.hp.com/go/e-updates>.

Subscribing to this service provides you with e-mail updates on the latest product enhancements, newest driver versions, and firmware documentation updates as well as instant access to numerous other product resources.

After subscribing, locate your products by selecting **Business support** and then **Storage** under Product Category.

Other HP web sites

For additional information, see the following HP web sites:

- <http://www.hp.com>
- <http://www.hp.com/go/storage>
- http://www.hp.com/service_locator
- <http://www.docs.hp.com>
- <http://welcome.hp.com/country/us/en/prodserv/servers.html>

1 Overview

The Brocade 4Gb SAN Switch for HP c-Class BladeSystem (referred to hereafter as the 4Gb SAN Switch) is a Fibre Channel (FC) switch that supports link speeds of up to 4 Gb/sec. The 4Gb SAN Switch can operate in a fabric containing multiple switches or as the only switch in a fabric.



NOTE:

In this document, the Brocade 4Gb SAN Switch refers to those Brocade FC switch modules compatible with the HP c-Class BladeSystem enclosure only.

This chapter provides the following information:

- [4Gb SAN Switch features](#)
- [Component identification](#)
- [ISL trunking groups](#)
- [Supported optional features](#)
- [Optional hardware kits](#)

4Gb SAN Switch features

The 4Gb SAN Switch provides the following features:

- Fully integrated, embedded FC SAN design connects directly to the HP c-Class BladeSystem enclosure midplane
- Dynamic Ports on Demand (DPOD), automatically detects port connections, assigns port licenses and enables ports
- Easy to manage HP Storage Essentials Systems Insight Manager support
- Full compatibility with HP StorageWorks B-Series switches and Brocade fabrics
- Sixteen internal 1/2/4 Gbps auto-sensing FC interconnect technology with the following characteristics:
 - Independent automatic negotiation to the highest common speed for each server FC port connected to the switch
 - Universal self-configuring ports, which are capable of becoming F_Ports (fabric enabled)
- Eight external 1/2/4 Gbps FC Small Form-factor Pluggable (SFP) ports, with the following characteristics:
 - Automatic negotiation to the highest common speed of all devices connected to the port
 - Port interface-compatible SFP transceivers, both short wavelength (SWL) and long wavelength (LWL)
 - Universal self-configuring ports, which are capable of becoming F_Ports (fabric enabled), FL_Ports (fabric loop enabled), or E_Ports (expansion ports)
- Heterogeneous support for mixed storage fabrics
- Power supplied and controlled by the BladeSystem enclosure
- Identification to HP chassis management via HP specified SEEPROMs
- Hot-swap capability
- Compatible with redundant and dual redundant switch configurations in c-Class BladeSystem
- Hot code activation
- Real-time clock
- SFP port monitoring

Component identification

Figure 1 and Table 2 identify the physical components of the 4Gb SAN Switch.

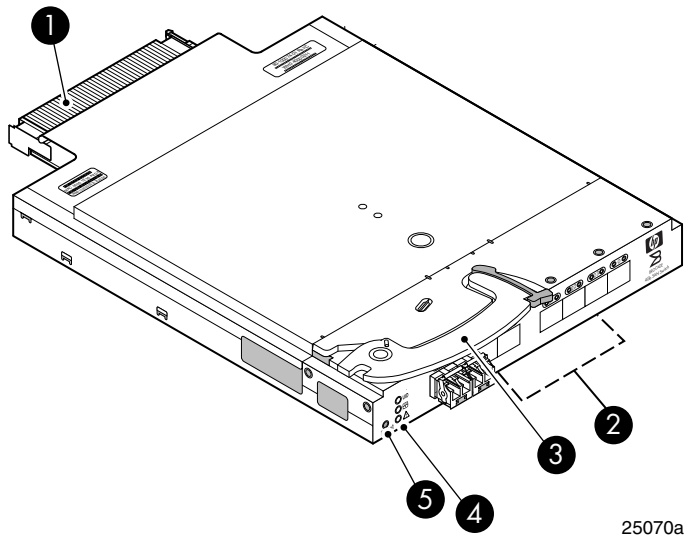

Figure 1 Identifying components

Table 2 Brocade 4Gb SAN Switch components

Item	Description
1	Midplane connector
2	Eight external SFP ports
3	Installation handle
4	Unit ID (UID), Health, and Status LEDs
5	Reset button

Port side of the 4Gb SAN Switch

Figure 2 and Table 3 identify 4Gb SAN Switch external ports (ports 17 through 20, and ports 21 through 0).

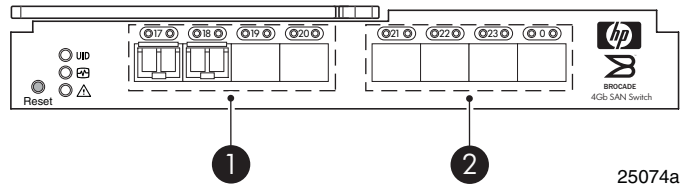

Figure 2 4Gb SAN Switch external ports

Table 3 Identifying 4Gb SAN Switch external ports

Item number	Description
1	Left bank — ports 17, 18, 19, 20
2	Right bank — ports 21, 22, 23, 0



NOTE:

Refer to [Interpreting LED activity](#) for complete information on 4GB SAN Switch LEDs.

Internal ports summary

Sixteen logical internal ports (numbered 1 through 16) connect sequentially to server bays 1 through 16 via the enclosure midplane. Server bay 1 is connected to Switch Port 1, Server bay 2 is connected to Switch port 2, and so forth.

4Gb SAN Switch redundancy

The HP c-Class BladeSystem was engineered as a no-single-point-of-failure bladed Solution. Attributes that contribute to switch redundancy include:

- Redundant power and cooling
- Redundant HP Onboard Administrator (OA) to ensure management access to the SAN Switch



NOTE:

The HP Onboard Administrator is the enclosure management module used to support and manage the HP c-Class BladeSystem and all managed devices used in the enclosure.

4Gb SAN Switch licensing

The 4Gb SAN Switch integrates one of three license options that complement existing HP product lines. Some 4Gb SAN Switch models ship with licenses that place limits on the number of domains that can be used. Models and their specific licenses are described next:

- Brocade 4/12 SAN Switch for HP c-Class BladeSystem, base, integrating 12 active ports (8 internal and 4 external) and two preinstalled short wavelength SFPs. Software components include a Full Fabric license, the Advanced Web Tools Graphical User Interface (GUI) and Zoning software
- Brocade 4/24 SAN Switch for HP c-Class BladeSystem, base, integrating 24 active ports (16 internal and 8 external) and four preinstalled short wavelength SFPs. Software components include a Full Fabric license, Advanced Web Tools GUI, and Zoning software
- Brocade 4/24 Gb SAN Switch for HP c-Class BladeSystem, Power Pack, integrating 24 active ports (16 internal and 8 external) and four preinstalled short wavelength SFPs. Software components include a Full Fabric license, Advanced Web Tools GUI, and Zoning software plus these additional software features:
 - Fabric Watch
 - ISL Trunking
 - Advanced Performance Monitoring (APM)
 - Extended Fabric



IMPORTANT:

Upgrade the 4Gb SAN Switch by purchasing optional licenses; access the latest version of the *HP StorageWorks Fabric OS administrator guide* to learn how to add a license.

ISL trunking groups

If your 4Gb SAN Switch is licensed for interswitch link (ISL) trunking, use the trunking groups available on the switch.

The FC ports are numbered from left to right, and are part of the same ISL trunking group. The trunking group consists of the ports shown in [Figure 2](#).



NOTE:

ISL Trunking is optional software that allows you to create trunking groups of ISLs between adjacent switches. ISL trunking is available on the Brocade 4Gb SAN Switch for HP c-Class BladeSystem Power Pack model, or by purchasing the optional license described in [Supported optional features](#). For more information about trunking, refer to the latest version of the *HP StorageWorks Fabric OS administrator guide*.

Supported optional features

The 4Gb SAN Switch includes the following optional software, which can be activated by purchasing the corresponding license key:

- Fabric Manager
- Secure Fabric OS (the Secure Fabric OS feature is standard in firmware versions 5.3.0 and later)
- ISL Trunking
- Fabric Watch
- Advanced Performance Monitoring (APM)
- Extended Fabrics

The 4Gb SAN Switch ships configured with the HP StorageWorks Full Fabric license, which includes the Zoning and Advanced Web Tools features.

If you purchased a 4Gb SAN Switch for HP c-Class BladeSystem Power Pack, it includes the following optional software:

- ISL Trunking
- Fabric Watch
- Advanced Performance Monitoring
- Extended Fabrics

For information on any of these features, refer to the latest version of the *HP StorageWorks Fabric OS administrator guide*.

Optional hardware kits

Table 4 lists optional hardware kits that support the 4Gb SAN Switch. For additional options, go to the HP web site:

<http://www.hp.com>

Table 4 Optional hardware

Accessory	Part number
Short wavelength SFP, 4Gb, 150m at 4Gb	A7446B
2 m LC-to-LC multimode FC cable	221692-B21
5 m LC-to-LC multimode FC cable	221691-B22
15 m LC-to-LC multimode FC cable	221692-B23
30 m LC-to-LC multimode FC cable	221692-B26
50 m LC-to-LC multimode FC cable	221692-B27
2 m LC-to-SC multimode FC cable	221691-B21
5 m LC-to-SC multimode FC cable	221691-B21
15 m LC-to-SC multimode FC cable	221692-B22

2 Setup

This chapter provides the following information:

- Shipping carton contents
- Installation and safety considerations
- Install the 4Gb SAN Switch
- Set the IP address
- Configure the 4Gb SAN Switch

Shipping carton contents

The 4Gb SAN Switch kit shipping carton contains three items, identified in [Figure 3](#) and [Table 5](#):

- *Brocade 4Gb SAN Switch for HP c-Class BladeSystem installation instructions*
- SFP dust covers (must be inserted in ports where Small Form-factor Pluggable (SFP) optical transceivers are not installed)
- One Brocade 4Gb SAN Switch with two or four SFPs installed. Models include:
 - Brocade 4/12 SAN Switch for HP c-Class BladeSystem with twelve active ports (ships with two Short Wavelength (SWL) 4Gb SFPs installed, as shown in [Figure 3](#))
 - Brocade 4/24 SAN Switch for HP c-Class BladeSystem with sixteen internal and eight external active ports (ships with four 4Gb SFPs installed)
 - Brocade 4/24 SAN Switch Power Pack for HP c-Class BladeSystem with sixteen internal and eight external active ports (ships with four 4Gb SFPs installed)

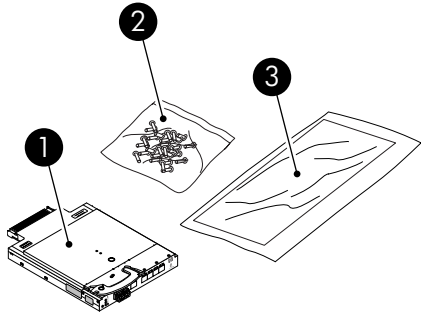

25202a

Figure 3 Carton contents

Table 5 identifies 4Gb SAN switch components.

Table 5 Brocade 4Gb SAN Switch components

Item	Description
1	Brocade 4Gb SAN Switch
2	Dust covers for empty SFP ports
3	<i>Brocade 4Gb SAN Switch for HP c-Class BladeSystem installation instructions</i>

Installation and safety considerations

The 4Gb SAN Switch installs in the I/O bays in the rear of the HP c-Class BladeSystem enclosure. Refer to the appropriate *BladeSystem Enclosure Setup and Installation Guide* for specific enclosure requirements.

Installing multiple switches

Install and configure one 4Gb SAN Switch at a time. This is required so that Ethernet IP address conflicts do not occur with duplicate default Ethernet IP addresses.

IMPORTANT:

DHCP is enabled by default for switches running Fabric OS 5.2.1b (switch rev 0C) or later. In cases where DHCP is available, IP address conflicts will not occur, simplifying multiple switch installations. See [Using External DHCP](#).

Each switch must be assigned a unique Ethernet IP address during configuration. Once the default Ethernet IP address on the 4Gb SAN Switch has been changed, you may install additional 4Gb SAN Switches in the enclosure.

See the appropriate *HP BladeSystem Enclosure Setup and Installation Guide* for help identifying your specific enclosure setup, available connections and power requirements.

Electrical considerations

The 4Gb SAN Switch requires 35 watts, provided by the enclosure. No other power requirement or provision exists.

Environmental considerations

Ensure proper cooling and ventilation by verifying the following:

- The air vents on the enclosure are not blocked or restricted.
- The ambient air temperature at the front of the enclosure does not exceed 35°C (95°F) while the switch is operating.



IMPORTANT:

The dust covers that ship with your 4Gb SAN switch *must* be inserted into any ports where SFPs are not installed, to help contain air flow in the BladeSystem chassis.

Install the 4Gb SAN Switch

△ **CAUTION:**

For switch revision levels 0A and 0B only (running Fabric OS versions earlier than 5.2.1b) — DHCP is not supported on these models. Do not install multiple switches at the same time with default addresses, as address conflicts will occur. Locate switch revision levels on the switch or shipping carton. See [Set the IP address](#).

For switch revision levels 0C and above only (Fabric OS 5.2.1b or later) — DHCP is supported and enabled by default for switches running Fabric OS 5.2.1b (switch rev 0C) or later. In this case, IP address conflicts will not occur during multiple switch installations. Locate switch revision levels on the switch or shipping carton. See [Using External DHCP](#).

The Brocade 4Gb SAN switch is a hot-pluggable device. The enclosure power may be on or off when inserting the switch. Follow these steps to install the 4Gb SAN Switch.

1. Locate the appropriate interconnect bay in the rear of the enclosure per the appropriate *HP BladeSystem Enclosure Setup and Installation Guide* provided with your enclosure.

Remove the slot cover (if installed).

 **IMPORTANT:**

Populate all enclosure I/O bays with the appropriate component (for example a switch, Pass-Thru or one of the blank panels provided with the enclosure).

△ **CAUTION:**

Properly ground yourself before handling the switch.

2. Press the handle latch to release the installation handle. See [Figure 4](#).

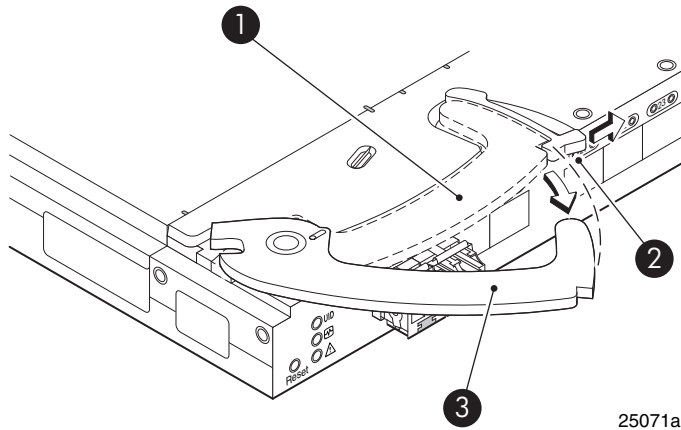

25071a

Figure 4 Releasing the installation handle

Table 6 Release mechanism components

Item	Description
1	Installation handle in latched position
2	Handle latch
3	Installation handle (released)

3. Align the Brocade 4Gb SAN Switch with the appropriate interconnect bay according to your enclosure's specific configuration. Push firmly into the interconnect bay. See [Figure 5](#).

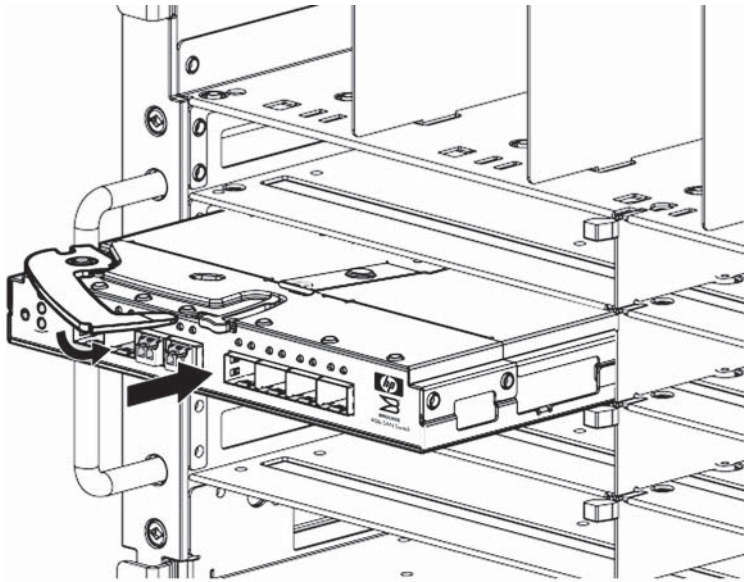

25319a

Figure 5 Installing the Brocade 4Gb SAN Switch into an interconnect bay

4. Press the installation handle into the latch to lock the Brocade 4Gb SAN Switch in place.

OA verifies power

As defined earlier, the HP BladeSystem Onboard Administrator (OA) is the enclosure management processor that manages the devices contained within the enclosure. The OA provides a single point from which to perform basic management tasks on switches or server blades installed in the enclosure.

IMPORTANT:

HP recommends reading the appropriate *HP BladeSystem Enclosure User Guide* and the *HP BladeSystem Onboard Administrator User Guide*. Reading these guides in sequence will promote an overall understanding of your specific enclosure model.

Once the switch is installed in the interconnect bay, the OA verifies that the switch type matches the mezzanine cards present on the servers. If there is no mismatch, the OA powers up the switch.

If the switch does not power up, check the enclosure and switch status via the OA web interface. Refer to the *HP BladeSystem Onboard Administrator User Guide*.

Checking LEDs

See [Figure 6](#) to locate power-on LEDs. Verify that the LEDs match the indicators described in [Table 7](#).

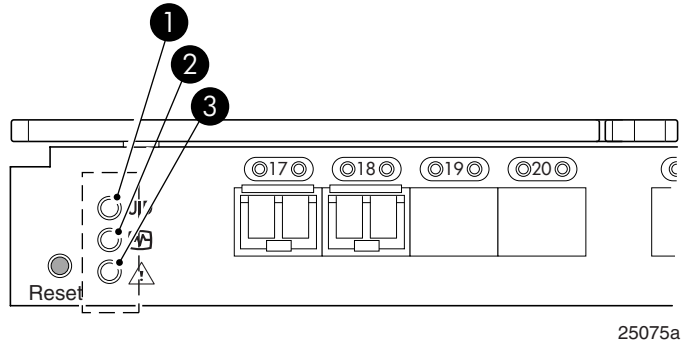

Figure 6 Verifying power-on LEDs

Table 7 Power-on LEDs

Item	Description	Indicators
1	UID LED	Off
2	Health ID LED	Steady green light
3	Module Status LED	Steady green light

Setting the IP address

IMPORTANT:

The switch supports DHCP beginning with Fabric OS 5.2.1b firmware. For switches running Fabric OS 5.2.1b (switch rev 0C) or later, DHCP is enabled by default, simplifying multiple switch installations. To enable or disable this feature, login with these default credentials and issue the `ipaddrset` command using:

- username: admin
 - password: password
-

To set the Ethernet IP address:

1. Verify that the enclosure is powered on.
2. Verify that the switch is installed.
3. Choose one of the following methods to set the Ethernet IP address:
 - [Using Enclosure Bay IP Addressing \(EBIPA\)](#)
 - [Using External DHCP](#)
 - [Setting the IP address manually](#)

Using Enclosure Bay IP Addressing (EBIPA)

To set the Ethernet IP address using EBIPA:

1. Connect to the active OA via a web browser.
2. Enable EBIPA for the corresponding interconnect bay.
3. Click the **Apply** button to restart the switch.
4. Verify the IP address using a telnet or ssh login to the switch, or by selecting the switch in the OA **GUI Rack Overview** window.

Using External DHCP

To set the Ethernet IP address using external DHCP:

1. Connect to the active OA via a web browser.
2. Document the DHCP-assigned address by selecting the switch from the OA **GUI Rack Overview** window.
3. Verify the IP address using a telnet or ssh login to the switch, or by selecting the switch in the OA GUI Rack Overview window.

Setting the IP address manually

IP addresses must be set manually for 4Gb SAN Switches with revision levels prior to rev 0C (running Fabric OS versions earlier than 5.2.1b). Switches with revision levels earlier than rev 0C do not support DHCP. Set IP addresses for these switches manually as follows:



NOTE:

As an alternate method to using a null modem cable, use telnet or ssh to access the IP address of the Onboard Administrator, resuming at step 9 below.

1. Obtain the following items to set the IP address via a serial connection:
 - Computer with a terminal application (such as HyperTerminal in a Windows environment or TERM in a UNIX environment)
 - Null modem serial cable
2. Replace the default IP address (if present) and related information with the information provided by your network administrator. By default, the IP address is set to 10.77.77.77 for switches with revision levels earlier than 0C.
3. Verify that the enclosure is powered on.
4. Identify the active OA in the BladeSystem.
5. Connect a Null modem serial cable from your computer to the serial port of the active OA.

6. Configure the terminal application as follows:

In a Windows environment, type:

- Bits per second — 9600
- Databits — 8
- Parity — None
- Stop bits — 1
- Flow control — None

In a UNIX environment, type: `tip /dev/ttyb -9600`

7. Log into the OA.

8. Press **Enter** to display the switch console.

9. Identify the interconnect bay number where the switch is installed. At the OA command line, type:

```
connect interconnect x
```

Where *x* is the interconnect bay slot where the switch is installed.

a. User: `admin`

b. Password: `password`



NOTE:

Type entries as shown, as commands are case sensitive.

10. Or, follow the onscreen prompts to change your password now.
11. The OA will then connect its serial line to the Switch in the specified interconnect bay. A prompt displays indicating that the escape character for returning to the OA is `Ctrl _` (underscore).
12. At the command line, type: `ipaddrset`.
13. Enter the remaining IP addressing information, as prompted.
14. Optionally, enter `ipaddrshow` at the command prompt to verify that the IP address is set correctly.
15. Record the IP addressing information and store in a safe place.
16. Type **Exit** and press **Enter** to log out of the serial console.
17. Disconnect the serial cable. For additional assistance with operating the Onboard Administrator CLI, refer to the *Onboard Administrator Command Line Interface user guide* for your specific enclosure, available at <http://www.hp.com>.

Configure the 4Gb SAN Switch

The 4Gb SAN Switch must be configured to ensure correct operation within a network and fabric. For instructions about configuring the switch to operate in a fabric containing switches from other vendors, refer to the *HP StorageWorks SAN Design reference guide*:

<http://h18000.www1.hp.com/products/storageworks/san/documentation.html>.

For more information about the CLI, refer to the latest version of the *Fabric OS command reference guide*.

Items required for configuration

The following items are required for configuring and connecting the 4Gb SAN Switch for use in a network and fabric:

- 4Gb SAN Switch installed in the enclosure
- IP address and corresponding subnet mask and gateway address recorded during the [Set the IP address](#) procedure
- Ethernet cable
- SFP transceivers and compatible optical cables, as required
- Access to an FTP server for backing up the switch configuration (optional)

Connecting to the Command Line Interface

Make an Ethernet connection and log into the 4Gb SAN Switch:

1. Connect the workstation to the Ethernet network containing the OA. If the OA is not on a network, connect directly to the OA/iLO Ethernet port on the active OA.



IMPORTANT:

Verify that the switch is not being re-configured from any other connections during the remaining steps.

2. Open a telnet connection using the IP address set earlier. The login prompt displays when the telnet connection locates the switch in the network.
3. Enter the user name, using the administrative account `admin`.
4. Enter the password. The default password is `password`.



NOTE:

Run up to two simultaneous `admin` sessions and four `user` sessions.

If you have not changed the system passwords from the default, you are prompted to change them. Enter the new system passwords, or press **Ctrl-c** to skip the password prompts.

5. Verify that the login was successful. If successful, the prompt displays the switch name and user ID to which you are connected.

Setting the date and time

Date and time are used for logging events. 4Gb SAN Switch operation does not depend on the date and time; a switch with an incorrect date and time value will function properly.

To set the date and time using the CLI:

1. If you have not already done so, connect to the switch and log in as `admin` as described in [Connect to the Command Line Interface](#).
2. Issue the date command using the following syntax:

```
date "mmddHHMMyy"
```

where:

- *mm* is the month; valid values are 01 through 12.
- *dd* is the date; valid values are 01 through 31.
- *HH* is the hour; valid values are 00 through 23.
- *MM* is minutes; valid values are 00 through 59.
- *yy* is the year; valid values are 00 through 99 (values greater than 69 are interpreted as 1970–1999, and values less than 70 are interpreted as 2000–2069).

For example:

```
switch:admin> date
Fri Jan 29 17:01:48 UTC 2000
switch:admin> date "0227123003
Thu Feb 27 12:30:00 UTC 2003
switch:admin>
```

For details about changing time zones, see the `tsTimezone` command in the latest version of the *Fabric OS command reference guide*.

Verifying installed licenses

To determine the type of licensing included with your 4Gb SAN Switch, type `licenseshow` at the command prompt as in the following **Example**:

Example 1.

```
switch:admin> licenseshow  
  
XXXnnXXnXnnXXX:  
  
Fabric Watch license  
  
Release v5.0 license  
  
XXXnnXXnXnnXXX:  
  
Zoning license  
  
XXXnnXXnXnnXXX:  
  
Web license  
  
XXXnnXXnXnnXXX:  
  
Full Fabric
```



NOTE:

For more information about the Command Line Interface (CLI), refer to the latest version of the *Fabric OS command reference guide*.

Modifying the FC domain ID (optional)

If desired, you can modify the FC domain ID. The default FC domain ID is domain 1. If the 4Gb SAN Switch is not powered on until after it is connected to the fabric and the default FC domain ID is already in use, the domain ID for the new switch is automatically reset to a unique value. If the switch is connected to the fabric after it has been powered on and the default domain ID is already in use, the fabric segments.

Type `fabricshow` to determine the domain IDs that are currently in use. The maximum number of domains with which the 4Gb SAN Switch communicates is determined by this switch's fabric license.

To modify the domain ID:

1. Type `switchdisable` to disable the switch.
2. Type `configure`, then type a new value.
Or press **Enter** to accept each default value.
3. At the Fabric parameters prompt, type **Y** and press **Enter**:

```
Fabric parameters (yes, y, no, n): [no] y
```

4. Enter a unique domain ID. For example:

```
Domain: (1..239) [1] 3
```
5. Complete the remaining prompts or press **Ctrl+D** to accept the remaining default settings.
6. Type `switchenable` to re-enable the switch.
7. Type `fabricshow` to confirm any changes made to the domain ID.
8. Optionally, verify switch policy settings and specify any custom status policies that need to change:
 - a. Type `switchstatuspolicyshow` to verify the current policy settings. If desired, type `switchstatuspolicyset` at the prompt to change switch policy settings. This command sets the policy parameters that determine the overall switch status.
 - b. Customize the status policies as desired.
9. To deactivate the alarm for a particular condition, enter **0** at the prompt for that condition.

Disabling and enabling a switch

By default, the switch is enabled after power on and diagnostics and switch initialization routines complete. You can disable and re-enable the switch as necessary.

To disable:

1. If you have not already done so, connect to the switch and log in as `admin` as described in [Connect to the Command Line Interface](#).
2. Issue the `switchDisable` command.

All Fibre Channel ports on the switch are taken offline. If the switch was part of a fabric, the fabric reconfigures.

To enable:

1. If you have not already done so, connect to the switch and log in as `admin` as described in [Connect to the Command Line Interface](#).
2. Issue the `switchEnable` command.

All Fibre Channel ports that pass the Power-on Self Test (POST) are enabled. If the switch has interswitch links (ISLs) to a fabric, it joins the fabric.

Disabling and enabling a port

To enable a port:

1. Connect to the switch and log in as `admin` as described in [Connect to the Command Line Interface](#).
2. Issue `portenable portnumber` where `portnumber` is the port number of the port you want to enable.

To disable:

1. If you have not already done so, connect to the switch and log in as `admin` as described in [Connect to the Command Line Interface](#).
2. Issue `portdisable portnumber` where `portnumber` is the port number of the port you want to disable.

Using Dynamic Ports On Demand (DPOD)

In the past, Ports On Demand (POD) functionality was static. A preset group of ports were individually enabled per each POD license. In contrast, the new DPOD functionality does not require a predefined assignment of ports. Port assignment is determined by the total number of ports in use as well as the number of purchased ports.

In summary, the DPOD feature simplifies port management by:

- automatically detecting HBA connected server ports or cabled ports.
- automatically enabling ports
- automatically assigning port licenses

To initiate DPOD, use the `licensePort` command, as described in [DPOD commands](#).



IMPORTANT:

For the Brocade 4Gb SAN Switch, DPOD works only if the server blade is installed with an HBA present. A server blade that does not have a functioning HBA will not be treated as an active link for the purpose of initial POD port assignment.

DPOD commands

Use the `licensePort` command to manage dynamic POD assignments with the following options:

- `licensePort -reserve portnum` reserves a future license assignment for a specific port, even if the port is currently offline.
- `licensePort -release portnum` removes a license from a port.
- `portCfgPersistentDisable` blocks a specific port from future assignments.
- `licensePort -show` displays an overview of the POD license status and port assignments.

The following shows examples of the `licensePort -show` command for a Brocade 4/12 SAN Switch and a Brocade 4/24 SAN Switch:

Example for Brocade 4/12 SAN Switch

```
swd77:admin> licenseport -show
24 ports are available in this switch
  No POD licenses are installed
  Dynamic POD method is in use
12 port assignments are provisioned for use in this switch:
12 port assignments are provisioned by the base switch license
*6 port assignments added if the 1st POD license is installed
*6 more assignments added if the 2nd POD license is installed
  4 ports are assigned to installed licenses:
    4 ports are assigned to the base switch license
Ports assigned to the base switch license:
  15, 16, 17, 18*
Ports assigned to the first POD license:
  None
Ports assigned to the second POD license:
  None
Ports not assigned to a license:
  0, 1, 2, 3, 4, 5, 6, 7, 8, 9, 10, 11, 12, 13, 14, 19
  20, 21, 22, 23
```

Example for Brocade 4/24 SAN Switch

```
cp081044:admin> licenseport --show
24 ports are available in this switch
  Full POD license is installed
  Dynamic POD method is in use
24 port assignments are provisioned for use in this switch:
12 port assignments are provisioned by the base
12 port assignments are provisioned by a full POD license
11 ports are assigned to installed licenses:
  11 ports are assigned to the base switch license
  0 ports are assigned to the full POD license
Ports assigned to the base switch license:
  1, 2, 3, 4, 5, 6, 7, 8, 17*, 18*, 19*
Ports assigned to the full POD license:
  None
Ports not assigned to a license:
  0, 9, 10, 11, 12, 13, 14, 15, 16, 20, 21, 22, 23

13 license reservations are still available for use by unassigned
ports
  3 license assignments are held by offline ports (indicated by *)
```



NOTE:

The DPOD feature does not consider disabled ports as candidates for license assignments. You can persistently disable an otherwise viable port to cause it not to come online and preserve a license assignment for future use.

Verifying the configuration

After setting initial parameters, verify the configuration as follows:

1. Check the LEDs to verify that all components are functional.
For information about LED patterns, refer to [Interpreting LED activity](#).
2. Type `switchshow` to get information about the switch and port status.
3. Type `fabricshow` to get general information about the fabric.

Backing up the configuration

HP recommends regular backups to ensure that a recent configuration is available, if required. For specific instructions on how to back up the configuration, refer to the latest version of the *HP StorageWorks Fabric OS administrator guide*.

To back up the switch configuration to an FTP server, type `configupl` and follow the prompts. The `configupl` command copies the switch configuration to the server, making it available for downloading to a replacement switch, if necessary.

3 Managing the 4Gb SAN Switch

This chapter provides the following information:

- Management features
- Maintaining the 4Gb SAN Switch
- Powering on and off
- Interpreting LED activity
- LED patterns
- POST and boot specifications
- Firmware update
- About the reset button
- Replacing a faulty 4Gb SAN Switch

Management features

The management tools built into the 4Gb SAN Switch (listed in [Table 8](#)) can be used to monitor fabric topology, port status, physical status, and other information used for performance analysis and system debugging.

When running IP over FC, these management tools must be run on both the Fibre Channel host and the switch and must be supported by the Fibre Channel host driver. For a list of Fibre Channel hosts supported by the 4Gb SAN Switch, contact your HP representative.

Table 8 4Gb SAN Switch management features

Management tool	Out-of-band support	In-band support
CLI — Run up to two admin sessions and four user sessions simultaneously. For more information, refer to the latest version of the <i>HP StorageWorks Fabric OS administrator guide</i> and the <i>Fabric OS command reference guide</i> .	Ethernet or serial connection	IP over FC
Advanced Web Tools — For information, refer to the latest version of the <i>Fabric OS Web Tools administrator's guide</i> .	Ethernet connection	IP over FC
Standard SNMP applications — For information, refer to the latest version of the <i>Fabric OS MIB reference guide</i> .	Ethernet connection	IP over FC
Management Server — For more information, refer to the latest version of the <i>HP StorageWorks Fabric OS administrator guide</i> and the <i>Fabric OS command reference guide</i> .	Ethernet connection	SMI-S compliant management program

You can connect a management station to one switch via Ethernet while managing other switches connected to the first switch via FC. To do so, set the FC gateway address of each of the other switches to be managed to the FC IP address of the first switch.

The gateway address of the first switch should be set to whatever the gateway address is for the subnet on which the first switch resides. See [Table 9](#).

Table 9 Connecting via a management station

	Management station	First switch	Second switch	Third switch
Ethernet	192.168.1.09	192.168.1.10	204.1.1.11	204.1.1.12
FCIP	192.168.65.09	192.168.65.10	192.168.65.11	192.168.65.12
Gateway	192.168.1.10	any, not self	192.168.1.10	192.168.1.10

Maintaining the 4Gb SAN Switch

The 4Gb SAN Switch does not require any regular physical maintenance.

However, it is critical that environmental conditions, described in [Environmental requirements](#) are met to help prevent switch failure due to heat stress or improper air flow.

Installing dust covers in empty ports

The dust covers included in the 4GB SAN Switch shipping carton, (see [Figure 1](#)) *must* be inserted in ports where SFPs are not installed. Installing dust covers ensures proper airflow and helps reduce dust contamination of the switch.

Replacing an SFP transceiver

In some cases you might need to reinstall an SFP transceiver.

To remove an SFP transceiver:

1. Press and hold the cable release.
2. Remove the cable from the transceiver.
3. Pull the bail (wire handle) to release the transceiver.
4. Grasp the bail, and gently but firmly pull the transceiver out of the port.
5. Repeat this procedure for the remaining ports as required.

To install a replacement SFP:

1. Make sure that the bail is in the unlocked position.
2. Orient the SFP with the appropriate port. See [Figure 7](#) and [Table 10](#).

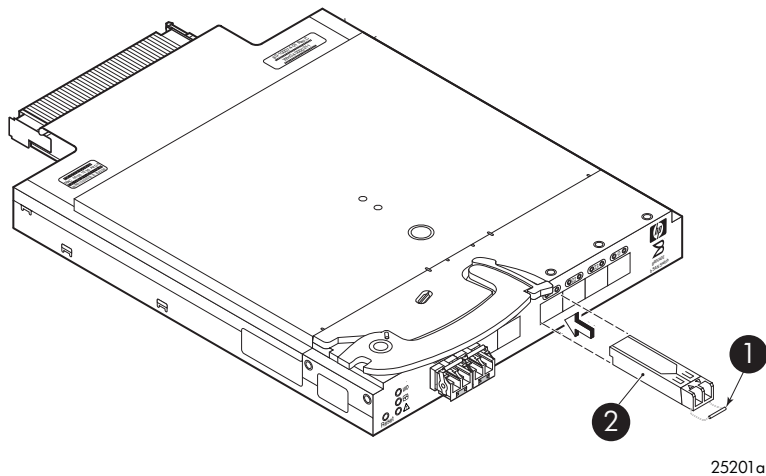

Figure 7 Installing an SFP

Table 10 SFP components

Item	Description
1	bail
2	SFP

3. Insert the SFP into the port until you hear a click.
4. Close the bail.

Diagnostic tests

In addition to POST, Fabric OS 5.x includes diagnostic tests to help troubleshoot the hardware and the firmware including tests of internal connections and circuitry, fixed media, and the transceivers and cables in use.

Initiate diagnostic tests via the command line, using a telnet session or a terminal setup with a serial connection to the switch. Some tests require the ports to be connected by external cables to allow diagnostics to verify the serializer/deserializer interface, transceiver, and cable. For information on available diagnostic tests, type `diagHelp`.

All diagnostic tests are run at link speeds of 1 Gb/sec, 2 Gb/sec, and 4 Gb/sec.

△ **CAUTION:**

Diagnostic tests can temporarily lock the transmit and receive speed of the links during diagnostic testing.

For information about specific diagnostic tests, refer to the latest version of the *HP StorageWorks Fabric OS administrator guide* or type `help` followed by the name of the diagnostic test.

Powering on and off

4Gb SAN Switch power is provided by the enclosure. The 4Gb SAN Switch will run POST by default each time power to the enclosure is turned on. The POST process can last as long as three minutes.

To remove power from the switch, remove the 4Gb SAN Switch from the enclosure interconnect bay.

 **NOTE:**

Each time the 4Gb SAN Switch is powered on, its settings are restored to the last saved configuration.

Interpreting LED activity

You can monitor switch activity and status by checking 4Gb SAN Switch LEDs.

There are three possible LED states: no light, a steady light, or a flashing light. The steady lights and flashing lights can be green or amber.

The LEDs flash any of these colors during boot, POST, or other diagnostic tests. This is normal and does not indicate a problem unless the LEDs do not indicate a healthy state after all boot processes and diagnostic tests are complete. A healthy state is indicated by a steady green light. See [Table 12](#) for details about LED activity.

LED indicators

All 4Gb SAN Switch LEDs are located on the port side. See [Figure 8](#) and [Table 11](#).

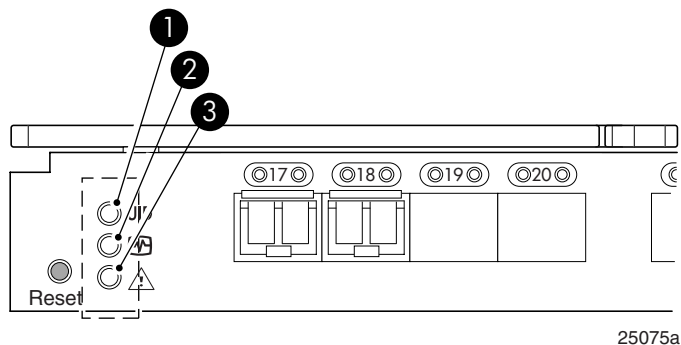

Figure 8 Identifying LEDs

Table 11 Front panel LED indicators during normal operation

Item Number	Description	LED indicators
1	Unit ID (UID) LED	Steady blue light
2	Health ID LED	Steady green light
3	Module Status LED	Steady green light
4	Port status LED	Steady green light
5	Port speed LED	Off, amber, or green

LED patterns

Table 12 and Table 13 summarize LED location, color, and meaning, as well as any recommended user response.

Module status LED patterns

The system and power LED patterns are shown in Table 12.

Table 12 Module Status LED patterns during normal operation

LED name, location	LED color	Status of hardware	Recommended action
Module Status LED	No light	Switch is off, boot is not complete, or boot failed.	Verify that switch is on and completed booting.
	Steady green	Switch is on and functioning.	No action required.
	Flashing green (on 1 second, off 1 second)	One or both of the following are true: <ul style="list-style-type: none">• One or more environmental ranges are exceeded.• Error log contains one or more port diagnostic error messages.	Check environmental conditions, error log, Port Status LEDs, transceivers, cables, and loopback plugs. Correct error condition. Clear error log. Rerun diagnostics to verify fix.
	Amber	Boot-up state, one or more ports offline.	Needs attention.

Port link status LED patterns

Table 13 shows the LED location, color, meaning, and recommended action.

Table 13 Port link status LED patterns

LED name, Location	LED color	Status of hardware	Recommended action
Port Status	No light	No light or signal carrier (transceiver or cable) detected.	Check transceiver and cable.
	Steady green	Port is online (connected to external device) but has no traffic.	No action required.
	Slow-flashing green (on 1 second, off 1 second)	Port is online but segmented, indicating a loopback cable or incompatible switch.	Verify that the correct device is connected to port and that the switch and port settings are correct.
	Fast-flashing green (on 1/2 second, off 1/2 second)	Port is in internal loopback (diagnostic).	No action required.
	Flickering green	Port is online with traffic flowing through port.	No action required.
	Steady amber	Port is receiving light or signal carrier, but is not yet online.	No action required.
	Slow-flashing amber (on 1 second, off 1 second)	Port is disabled as a result of diagnostics or <code>portDisable</code> command. If the LEDs for all ports are slow-flashing amber, the switch could be disabled.	Enable the port using the <code>portEnable</code> command; If the LEDs for all ports are slow-flashing amber, enable the switch by entering the <code>switchEnable</code> command.
	Fast-flashing amber (on 1/2 second, off 1/2 second)	Port is faulty.	Check the Port Status LEDs, error log, transceiver, and cable or loopback plug. Clear the error log. Rerun the diagnostics to verify that the error condition is fixed.
	Alternating green and amber	Port is bypassed.	Check configuration of FC loop.

Port link speed LED patterns

The following indicates port speeds:

- No light — 1Gbps
- Green — 2 Gbps
- Amber — 4 Gbps
- Shows Green/Amber — Invalid

POST and boot specifications

POST is a system check that is performed each time the switch is powered on, rebooted, or reset. During POST, the LEDs flash different colors. Any errors that occur during POST are listed in the error log.

The 4Gb SAN Switch performs POST when it is turned on or rebooted. Total boot time with POST is approximately three minutes.

POST can be omitted for subsequent reboots by using the `fastboot` command. For more information about this command, refer to the latest version of the *Fabric OS command reference guide*. If you suspect a problem with the switch, enable POST to obtain more information on any failure.

POST

The success/failure results of the diagnostic tests that run during POST can be monitored through the error log or the command line interface.

POST includes the following steps:

- Preliminary POST diagnostics are run.
- Operating system is initialized.
- Hardware is initialized.
- Diagnostic tests are run on several functions, including circuitry, port functionality, memory, statistics counters, and serialization.

Boot

Boot completes in approximately three minutes if POST is run. Boot includes the following tasks after POST completes:

- Universal port configuration
- Links initialized
- Fabric is analyzed; if any ports are connected to other switches, the 4Gb SAN Switch participates in a fabric configuration

- The 4Gb SAN Switch obtains a domain ID and assigns port addresses
- Unicast routing tables constructed
- Normal port operation enabled

Interpreting POST results

To determine whether POST completed successfully and whether any errors were detected:

1. Verify that the 4Gb SAN Switch LEDs indicate all components are healthy. See [Table 13](#) for description and interpretation of LED patterns. If one or more LEDs do not display a Healthy state, use the `switchshow` command to verify that the LEDs on the switch are not set to "beacon".
2. Verify that the 4Gb SAN Switch prompt appears on the terminal of a computer workstation connected to the switch. If there is no switch prompt when POST completes, press **Enter**. If the switch prompt still does not appear, try opening another telnet session or another management tool. If this is not successful, the 4Gb SAN Switch did not successfully complete POST; contact HP.
3. Review the switch system log for errors. Any errors detected during POST are written to the system log, accessible through the `errshow` command.

For information about all referenced commands and accessing the error log, refer to the latest version of the *HP StorageWorks Fabric OS administrator guide*. For information about error messages, refer to the *Fabric OS system error messages reference manual*.

Firmware update

To achieve best performance, HP recommends running the latest firmware release. Obtain the most current Fabric OS firmware, configuration files and MIB files that support this switch from the following HP web site:

<http://www.hp.com/go/storageworks/4gbswitchforc-classbladesystem>

To download firmware from the web to another computer (like an FTP server):



NOTE:

Web retrieval procedures may be subject to change.

1. Go to the **Support** section, located on the far right side of the web page. Click **Software & drivers**.
2. Locate the **Tasks for Brocade 4Gb SAN Switch for HP c-Class BladeSystem** section.
3. Click **Download drivers and software**.
 - a. Select the applicable switch model.
 - b. Go to the **Select Operating System** section. Click **Cross operating system (BIOS, Firmware, Diagnostics, etc.)**
 - c. Scroll down to the firmware section of the web page and locate the Firmware table.
 - d. Locate the latest firmware.
 - e. Click **Download button>>** in the last column and follow the prompts in the File Download dialog box.
4. To download the code from an FTP server to the switch, connect an Ethernet cable from the FTP server to the iLO RJ45 on the active OA.
5. Telnet to the switch and issue `firmwaredownload` at the command line.

About the reset button

The Brocade 4Gb SAN Switch integrates a Reset button, as shown in [Figure 9](#). The Reset button is a small, recessed micro-switch that is accessed by inserting a pin (or object of similar size) in the small hole.

Use the Reset button to reboot the switch.

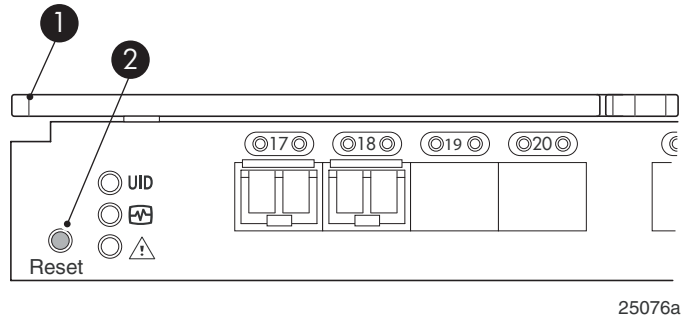

25076a

Figure 9 Locating the Reset button

Table 14 Locating the reset button

Item	Description
1	Port side of switch
2	Reset button

Rebooting the switch

Depress the Reset button for up to 5 seconds to reboot the switch.

Replacing a faulty 4Gb SAN Switch

To replace a faulty switch in the c-Class enclosure:

IMPORTANT:

For supplemental information on any of these steps refer to the latest *HP StorageWorks Fabric OS administrator guide* and *Fabric OS Advanced Web Tools administrator guide* available at: <http://www.hp.com/support/manuals>

To access the guides, scroll to the **storage** section of the web page and select **Storage Networking** for HP StorageWorks products.

In addition to these guides, refer to the **Brocade 4Gb SAN Switch for HP c-Class BladeSystem – Setup, Configuration and Installation Procedures** available on <http://www.hp.com> for initial installation instructions of the new switch.

1. Create a backup of the existing configuration file.

NOTE:

It is critical to back up the switch configuration on a regular basis to a remote server. Repeat for each switch in your SAN whenever configuration changes occur. Configuration backups can be done via the CLI, integrated Web Tools GUI, or the optional Fabric Manager GUI.

2. Locate the faulty switch.
3. Disconnect all external Fibre Channel cables.
4. Remove the faulty 4Gb SAN Switch from the enclosure.
5. Insert the replacement switch into the enclosure.
6. Log into the Onboard Administrator CLI.
7. Connect to the switch console, type:

```
connect interconnect <bay number>
```
8. Change the password when prompted by the switch.
9. To restore the configuration, you must disable the switch via the CLI, integrated Web Tools GUI or the optional Fabric Manager GUI.



NOTE:

If using the CLI, type `switchDisable` at the prompt. Refer to the *Fabric OS command reference guide* for additional command information.

10. Continue with the switch configuration. Enter the appropriate information when prompted. Make sure that the data entered matches the settings on the faulty switch.
11. Install the same Fabric OS version as the faulty switch using the CLI command `firmwareDownload`, the integrated Web Tools GUI or the optional Fabric Manager GUI.
12. Verify that the appropriate licenses are installed on the replacement switch.
13. Save the switch configuration file after making your edits, type:
`configupload`
14. Restore the switch configuration from the remote server using the backup configuration file from step 1.
15. Enable the switch. Use the CLI command `switchenable`, the integrated Web Tools GUI or the optional Fabric Manager GUI.
16. Connect all external FC cables in the same port locations as before. To connect to the external switch ports without connectivity to external devices, the external switch port must be disabled prior to inserting the cable and then re-enabled after inserting the cable to establish connectivity.
17. Verify that the switch is joined to the fabric and all connected devices log into the switch, type:
`switchshow`
18. Save the configuration file.



IMPORTANT:

HP recommends upgrading all switches in the enclosure to the latest available firmware. Check <http://www.hp.com> for updates.

A Regulatory compliance and safety

Regulatory compliance

Federal Communications Commission notice for Class A equipment

This equipment has been tested and found to comply with the limits for a Class A digital device, pursuant to Part 15 of the FCC Rules. These limits are designed to provide reasonable protection against harmful interference when the equipment is operated in a commercial environment. This equipment generates, uses and can radiate radio frequency energy and, if not installed and used in accordance with the instruction manual, may cause harmful interference to radio communications. Operation of this equipment in a residential area is likely to cause harmful interference, in which case the user will be required to correct the interference at his own expense. The end user of this product should be aware that any changes or modifications made to this equipment without the approval of Hewlett-Packard could result in the product not meeting the Class A limits, in which case the FCC could void the user's authority to operate the equipment.

Declaration of conformity for products marked with the FCC logo, United States only

This device complies with Part 15 of the FCC Rules. Operation is subject to the following two conditions: (1) this device may not cause harmful interference, and (2) this device must accept any interference received, including interference that may cause undesired operation.

For questions regarding your product, visit <http://www.hp.com>.

For questions regarding this FCC declaration, contact us by mail or telephone:

- Hewlett-Packard Company
P.O. Box 692000, Mailstop 510101
Houston, TX 77269-2000
- 1-281-514-3333

To identify this product, refer to the part, Regulatory Model Number, or product number found on the product.

Modifications

The FCC requires the user to be notified that any changes or modifications made to this device that are not expressly approved by Hewlett-Packard Company may void the user's authority to operate the equipment.

Cables

Connections to this device must be made with shielded cables with metallic RFI/EMI connector hoods in order to maintain compliance with FCC Rules and Regulations.

Regulatory compliance identification numbers

For the purpose of regulatory compliance certifications and identification, your product has been assigned a unique Regulatory Model Number. The RMN can be found on the product nameplate label, along with all required approval markings and information. When requesting compliance information for this product, always refer to this RMN. The Regulatory Model Number should not be confused with the marketing name or model number of the product.

The Regulatory Model Number for the Brocade 4Gb SAN Switch is:

HSTNS-1B10

Laser device

All HP systems equipped with a laser device comply with safety standards, including International Electrotechnical Commission (IEC) 825. With specific regard to the laser, the equipment complies with laser product performance standards set by government agencies as a Class 1 laser product. The product does not emit hazardous light.

Laser safety warning

WARNING!

To reduce the risk of exposure to hazardous radiation:

- Do not try to open the laser device enclosure. There are no user-serviceable components inside.
 - Do not operate controls, make adjustments, or perform procedures to the laser device other than those specified herein.
 - Allow only HP authorized service technicians to repair the laser device.
-

Certification and classification information

This product contains a laser internal to the fiber optic (FO) transceiver for connection to the Fibre Channel communications port.

In the USA, the FO transceiver is certified as a Class 1 laser product conforming to the requirements contained in the Department of Health and Human Services (DHHS) regulation 21 CFR, Subchapter J. A label on the plastic FO transceiver housing indicates the certification.

Outside the USA, the FO transceiver is certified as a Class 1 laser product conforming to the requirements contained in IEC 825-1:1993 and EN 60825-1:1994, including Amendment 11:1996 and Amendment 2:2001.

Laser product label

The optional label in [Figure 10](#) or equivalent may be located on the surface of the HP supplied laser device.



Figure 10 Class 1 laser product label

This optional label indicates that the product is classified as a CLASS 1 LASER PRODUCT. This label may appear on the laser device installed in your product.

International notices and statements

Canadian notice (avis Canadien)

Class A equipment

This Class A Digital apparatus meets all requirements of the Canadian Interference-Causing Equipment Regulations.

Cet appareil numérique de la classe A respecte toutes les exigences du Règlement sur le matériel brouilleur du Canada.

European Union notice

Products bearing the CE Marking comply with both the EMC Directive (89/336/EEC) and the Low Voltage Directive (73/23/EEC) issued by the Commission of the European Community and if this product has telecommunication functionality, the R&TTE Directive (1995/5/EC).

Compliance with these directives implies conformity to the following European Norms (the equivalent international standards and regulations are in parentheses):

- EN55022 (CISPR 22) – Electromagnetic Interference
- EN55024 (IEC61000-4-2, IEC61000-4-3, IEC61000-4-4, IEC61000-4-5, IEC61000-4-6, IEC61000-4-8, IEC61000-4-11) – Electromagnetic Immunity
- EN61000-3-2 (IEC61000-3-2) – Power Line Harmonics
- EN61000-3-3 (IEC61000-3-3) – Power Line Flicker
- EN60950 (IEC60950) – Product Safety
- Also approved under UL 60950/CSA C22.2 No. 60950-00, Safety of Information Technology Equipment.

BSMI notice

警告使用者:

這是甲類的資訊產品，在居住的環境中使用時，可能會造成射頻干擾，在這種情況下，使用者會被要求採取某些適當的對策。

Japanese notice

ご使用になっている装置にVCCIマークが付いていましたら、次の説明文をお読み下さい。

この装置は、情報処理装置等電波障害自主規制協議会（VCCI）の基準に基づくクラスB情報技術装置です。この装置は、家庭環境で使用することを目的としていますが、この装置がラジオやテレビジョン受信機に近接して使用されると、受信障害を引き起こすことがあります。

取扱説明書に従って正しい取り扱いをして下さい。

VCCIマークが付いていない場合には、次の点にご注意下さい。

この装置は、情報処理装置等電波障害自主規制協議会（VCCI）の基準に基づくクラスA情報技術装置です。この装置を家庭環境で使用すると電波妨害を引き起こすことがあります。この場合には使用者が適切な対策を講ずるよう要求されることがあります。

Korean notices

A급 기기 (업무용 정보통신기기)

이 기기는 업무용으로 전자파적합등록을 한 기기이오니 판매자 또는 사용자는 이 점을 주의하시기 바라며, 만약 잘못판매 또는 구입하였을 때에는 가정용으로 교환하시기 바랍니다.

B급 기기 (가정용 정보통신기기)

이 기기는 가정용으로 전자파적합등록을 한 기기로서 주거지역에서는 물론 모든지역에서 사용할 수 있습니다.

Safety

Battery replacement notice

Your switch is equipped with a lithium manganese dioxide, a vanadium pentoxide, or an alkaline internal battery or battery pack. There is a danger of explosion and risk of personal injury if the battery is incorrectly replaced or mistreated. Replacement is to be done by an HP authorized service provider using the HP spare part designated for this product. For more information about battery replacement or proper disposal, contact an HP authorized service provider.

⚠ WARNING!

Your switch contains an internal lithium manganese dioxide, a vanadium pentoxide, or an alkaline battery pack. There is risk of fire and burns if the battery pack is not properly handled. To reduce the risk of personal injury:

- Do not attempt to recharge the battery.
- Do not expose to temperatures higher than 60 °C.
- Do not disassemble, crush, puncture, short external contacts, or dispose of in fire or water.
- Replace only with the HP spare part designated for this product.



Batteries, battery packs, and accumulators should not be disposed of together with the general household waste. To forward them to recycling or proper disposal, please use the public collection system or return them to HP, an authorized HP Partner, or their agents.

For more information about battery replacement or proper disposal, contact an HP authorized reseller or service provider.

Taiwan battery recycling notice



The Taiwan EPA requires dry battery manufacturing or importing firms in accordance with Article 15 of the Waste Disposal Act to indicate the recovery marks on the batteries used in sales, giveaway, or promotion. Contact a qualified Taiwanese recycler for proper battery disposal.

Power cords

The power cord set must meet the requirements for use in the country where the product was purchased. If the product is to be used in another country, purchase a power cord that is approved for use in that country.

The power cord must be rated for the product and for the voltage and current marked on the product electrical ratings label. The voltage and current rating of the cord should be greater than the voltage and current rating marked on the product. In addition, the diameter of the wire must be a minimum of 1.00 mm² or 18 AWG, and the length of the cord must be between 1.8 m, (6 ft) and 3.6 m (12 ft). If you have questions about the type of power cord to use, contact an HP authorized service provider.

NOTE:

Route power cords so that they will not be walked on and cannot be pinched by items placed upon or against them. Pay particular attention to the plug, electrical outlet, and the point where the cords exit from the product.

Japanese power cord statement

製品には、同梱された電源コードをお使い下さい。
同梱された電源コードは、他の製品では使用出来ません。

Waste Electrical and Electronic Equipment directive

English notice

Disposal of waste equipment by users in private households in the European Union



■ This symbol on the product or on its packaging indicates that this product must not be disposed of with your other household waste. Instead, it is your responsibility to dispose of your waste equipment by handing it over to a designated collection point for recycling of waste electrical and electronic equipment. The separate collection and recycling of your waste equipment at the time of disposal will help to conserve natural resources and ensure that it is recycled in a manner that protects human health and the environment. For more information about where you can drop off your waste equipment for recycling, please contact your local city office, your household waste disposal service, or the shop where you purchased the product.

Dutch notice

Verwijdering van afgedankte apparatuur door privé-gebruikers in de Europese Unie



■ Dit symbool op het product of de verpakking geeft aan dat dit product niet mag worden gedeponeerd bij het normale huishoudelijke afval. U bent zelf verantwoordelijk voor het inleveren van uw afgedankte apparatuur bij een inzamelingspunt voor het recyclen van oude elektrische en elektronische apparatuur. Door uw oude apparatuur apart aan te bieden en te recyclen, kunnen natuurlijke bronnen worden behouden en kan het materiaal worden hergebruikt op een manier waarmee de volksgezondheid en het milieu worden beschermd. Neem contact op met uw gemeente, het afvalinzamelingsbedrijf of de winkel waar u het product hebt gekocht voor meer informatie over inzamelingspunten waar u oude apparatuur kunt aanbieden voor recycling.

Czechoslovakian notice

Likvidace zařízení soukromými domácími uživateli v Evropské unii



■ Tento symbol na produktu nebo balení označuje výrobek, který nesmí být vyhozen spolu s ostatním domácím odpadem. Povinností uživatele je předat takto označený odpad na předem určené sběrné místo pro recyklaci elektrických a elektronických zařízení. Okamžité třídění a recyklace odpadu pomůže uchovat přírodní prostředí a zajistí takový způsob recyklace, který ochrání zdraví a životní prostředí člověka. Další informace o možnostech odevzdání odpadu k recyklaci získáte na příslušném obecním nebo městském úřadě, od firmy zabývající se sběrem a svozem odpadu nebo v obchodě, kde jste produkt zakoupili.

Estonian notice

Seadmete jäätmete kõrvaldamine eramajapidamistes Euroopa Liidus



■ See tootel või selle pakendil olev sümbol näitab, et kõnealust toodet ei tohi koos teiste majapidamisjäätmetega kõrvaldada. Teie kohus on oma seadmete jäätmed kõrvaldada, viies need elektri- ja elektroonikaseadmete jäätmete ringlussevõtmiseks selleks ettenähtud kogumispunkti. Seadmete jäätmete eraldi kogumine ja ringlussevõtmine kõrvaldamise ajal aitab kaitsta loodusvarasid ning tagada, et ringlussevõtmine toimub viisil, mis kaitseb inimeste tervist ning keskkonda. Lisateabe saamiseks selle kohta, kuhu oma seadmete jäätmed ringlussevõtmiseks viia, võtke palun ühendust oma kohaliku linnakantselei, majapidamisjäätmete kõrvaldamise teenistuse või kauplusega, kust Te toote ostsite.

Finnish notice

Laitteiden hävittäminen kotitalouksissa Euroopan unionin alueella



■ Jos tuotteessa tai sen pakkauksessa on tämä merkki, tuotetta ei saa hävittää kotitalousjätteiden mukana. Tällöin hävitettävä laite on toimitettava sähkölaitteiden ja elektronisten laitteiden kierrätyspisteeseen. Hävitettävien laitteiden erillinen käsittely ja kierrätys auttavat säästämään luonnonvaroja ja varmistamaan, että laite kierrätetään tavalla, joka estää terveyshaitat ja suojelee luont. Lisätietoja paikoista, joihin hävitettävät laitteet voi toimittaa kierrätettäväksi, saa ottamalla yhteyttä jätehuoltoon tai liikkeeseen, josta tuote on ostettu.

French notice

Élimination des appareils mis au rebut par les ménages dans l'Union européenne



■ Le symbole apposé sur ce produit ou sur son emballage indique que ce produit ne doit pas être jeté avec les déchets ménagers ordinaires. Il est de votre responsabilité de mettre au rebut vos appareils en les déposant dans les centres de collecte publique désignés pour le recyclage des équipements électriques et électroniques. La collecte et le recyclage de vos appareils mis au rebut indépendamment du reste des déchets contribue à la préservation des ressources naturelles et garantit que ces appareils seront recyclés dans le respect de la santé humaine et de l'environnement. Pour obtenir plus d'informations sur les centres de collecte et de recyclage des appareils mis au rebut, veuillez contacter les autorités locales de votre région, les services de collecte des ordures ménagères ou le magasin dans lequel vous avez acheté ce produit.

German notice

Entsorgung von Altgeräten aus privaten Haushalten in der EU



Das Symbol auf dem Produkt oder seiner Verpackung weist darauf hin, dass das Produkt nicht über den normalen Hausmüll entsorgt werden darf. Benutzer sind verpflichtet, die Altgeräte an einer Rücknahmestelle für Elektro- und Elektronik-Altgeräte abzugeben. Die getrennte Sammlung und ordnungsgemäße Entsorgung Ihrer Altgeräte trägt zur Erhaltung der natürlichen Ressourcen bei und garantiert eine Wiederverwertung, die die Gesundheit des Menschen und die Umwelt schützt. Informationen dazu, wo Sie Rücknahmestellen für Ihre Altgeräte finden, erhalten Sie bei Ihrer Stadtverwaltung, den örtlichen Müllentsorgungsbetrieben oder im Geschäft, in dem Sie das Gerät erworben haben.

Greek notice

Απόρριψη άχρηστου εξοπλισμού από χρήστες σε ιδιωτικά νοικοκυριά στην Ευρωπαϊκή Ένωση



Το σύμβολο αυτό στο προϊόν ή τη συσκευασία του υποδεικνύει ότι το συγκεκριμένο προϊόν δεν πρέπει να διατίθεται μαζί με τα άλλα οικιακά σας απορρίμματα. Αντίθετα, είναι δική σας ευθύνη να απορρίψετε τον άχρηστο εξοπλισμό σας παραδίδοντάς τον σε καθορισμένο σημείο συλλογής για την ανακύκλωση άχρηστου ηλεκτρικού και ηλεκτρονικού εξοπλισμού.

Η ξεχωριστή συλλογή και ανακύκλωση του άχρηστου εξοπλισμού σας κατά την απόρριψη θα συμβάλει στη διατήρηση των φυσικών πόρων και θα διασφαλίσει ότι η ανακύκλωση γίνεται με τρόπο που προστατεύει την ανθρώπινη υγεία και το περιβάλλον. Για περισσότερες πληροφορίες σχετικά με το πού μπορείτε να παραδώσετε τον άχρηστο εξοπλισμό σας για ανακύκλωση, επικοινωνήστε με το αρμόδιο τοπικό γραφείο, την τοπική υπηρεσία διάθεσης οικιακών απορριμμάτων ή το κατάστημα όπου αγοράσατε το προϊόν.

Hungarian notice

Készülékek magánháztartásban történő selejtezése az Európai Unió területén



■ A készüléken, illetve a készülék csomagolásán látható azonos szimbólum annak jelzésére szolgál, hogy a készülék a selejtezés során az egyéb háztartási hulladéktól eltérő módon kezelendő. A vásárló a hulladékká vált készüléket köteles a kijelölt gyűjtőhelyre szállítani az elektromos és elektronikai készülékek újrahasznosítása céljából. A hulladékká vált készülékek selejtezés kori begyűjtése és újrahasznosítása hozzájárul a természeti erőforrások megőrzéséhez, valamint biztosítja a selejtezett termékek környezetre és emberi egészségre nézve biztonságos feldolgozását. A begyűjtés pontos helyéről bővebb tájékoztatást a lakhelye szerint illetékes önkormányzattól, az illetékes személtakarító vállalatától, illetve a terméket elárúsító helyen kaphat.

Italian notice

Smaltimento delle apparecchiature da parte di privati nel territorio dell'Unione Europea



■ Questo simbolo presente sul prodotto o sulla sua confezione indica che il prodotto non può essere smaltito insieme ai rifiuti domestici. È responsabilità dell'utente smaltire le apparecchiature consegnandole presso un punto di raccolta designato al riciclo e allo smaltimento di apparecchiature elettriche ed elettroniche. La raccolta differenziata e il corretto riciclo delle apparecchiature da smaltire permette di proteggere la salute degli individui e l'ecosistema. Per ulteriori informazioni relative ai punti di raccolta delle apparecchiature, contattare l'ente locale per lo smaltimento dei rifiuti, oppure il negozio presso il quale è stato acquistato il prodotto.

Latvian notice

Nolietotu iekārtu iznīcināšanas noteikumi lietotājiem Eiropas Savienības privātajās māsaimniecībās



Šāds simbols uz izstrādājuma vai uz tā iesaiņojuma norāda, ka šo izstrādājumu nedrīkst izmest kopā ar citiem sadzīves atkritumiem. Jūs atbildat par to, lai nolietotās iekārtas tiktu nodotas speciāli iekārtotos punktos, kas paredzēti izmantoto elektrisko un elektronisko iekārtu savākšanai otrreizējai pārstrādei. Atsevišķa nolietoto iekārtu savākšana un otrreizējā pārstrāde palīdzēs saglabāt dabas resursus un garantēs, ka šīs iekārtas tiks otrreizēji pārstrādātas tādā veidā, lai pasargātu vidi un cilvēku veselību. Lai uzzinātu, kur nolietotās iekārtas var izmest otrreizējai pārstrādei, jāvēršas savas dzīves vietas pašvaldībā, sadzīves atkritumu savākšanas dienestā vai veikalā, kurā izstrādājums tika nopirkts.

Lithuanian notice

Vartotojų iš privačių namų ūkių įrangos atliekų šalinimas Europos Sąjungoje



Šis simbolis ant gaminio arba jo pakuotės rodo, kad šio gaminio šalinti kartu su kitomis namų ūkio atliekomis negalima. Šalintinas įrangos atliekas privalote pristatyti į specialią surinkimo vietą elektros ir elektroninės įrangos atliekoms perdirbti. Atskirai surenkamos ir perdirbamos šalintinos įrangos atliekos padės saugoti gamtinius išteklius ir užtikrinti, kad jos bus perdirbtos tokiu būdu, kuris nekenkia žmonių sveikatai ir aplinkai. Jeigu norite sužinoti daugiau apie tai, kur galima pristatyti perdirbtinas įrangos atliekas, kreipkitės į savo seniūniją, namų ūkio atliekų šalinimo tarnybą arba parduotuvę, kurioje įsigijote gaminį.

Polish notice

Pozbywanie się zużytego sprzętu przez użytkowników w prywatnych gospodarstwach domowych w Unii Europejskiej



■ Ten symbol na produkcie lub jego opakowaniu oznacza, że produktu nie wolno wyrzucać do zwykłych pojemników na śmieci. Obowiązkiem użytkownika jest przekazanie zużytego sprzętu do wyznaczonego punktu zbiórki w celu recyklingu odpadów powstałych ze sprzętu elektrycznego i elektronicznego. Osobna zbiórka oraz recykling zużytego sprzętu pomogą w ochronie zasobów naturalnych i zapewnią ponowne wprowadzenie go do obiegu w sposób chroniący zdrowie człowieka i środowisko. Aby uzyskać więcej informacji o tym, gdzie można przekazać zużyty sprzęt do recyklingu, należy się skontaktować z urzędem miasta, zakładem gospodarki odpadami lub sklepem, w którym zakupiono produkt.

Portuguese notice

Descarte de Lixo Elétrico na Comunidade Europeia



■ Este símbolo encontrado no produto ou na embalagem indica que o produto não deve ser descartado no lixo doméstico comum. É responsabilidade do cliente descartar o material usado (lixo elétrico), encaminhando-o para um ponto de coleta para reciclagem. A coleta e a reciclagem seletivas desse tipo de lixo ajudarão a conservar as reservas naturais; sendo assim, a reciclagem será feita de uma forma segura, protegendo o ambiente e a saúde das pess. Para obter mais informações sobre locais que reciclam esse tipo de material, entre em contato com o escritório da HP em sua cidade, com o serviço de coleta de lixo ou com a loja em que o produto foi adquirido.

Slovakian notice

Likvidácia vyradených zariadení v domácnostiach v Európskej únii



Symbol na výrobku alebo jeho balení označuje, že daný výrobok sa nesmie likvidovať s domovým odpadom. Povinnosťou spotrebiteľa je odovzdať vyradené zariadenie v zbernom mieste, ktoré je určené na recykláciu vyradených elektrických a elektronických zariadení. Separovaný zber a recyklácia vyradených zariadení prispieva k ochrane prírodných zdrojov a zabezpečuje, že recyklácia sa vykonáva spôsobom chrániacim ľudské zdravie a životné prostredie. Informácie o zberných miestach na recykláciu vyradených zariadení vám poskytne miestne zastupiteľstvo, spoločnosť zabezpečujúca odvoz domového odpadu alebo obchod, v ktorom ste si výrobok zakúpili.

Slovenian notice

Odstranjevanje odslužene opreme uporabnikov v zasebnih gospodinjstvih v Evropski uniji



Ta znak na izdelku ali njegovi embalaži pomeni, da izdelka ne smete odvreči med gospodinjske odpadke. Nasprotno, odsluženo opremo morate predati na zbirališče, pooblaščen za recikliranje odslužene električne in elektronske opreme. Ločeno zbiranje in recikliranje odslužene opreme prispeva k ohranjanju naravnih virov in zagotavlja recikliranje te opreme na zdravju in okolju neškodljiv način. Za podrobnejše informacije o tem, kam lahko odpeljete odsluženo opremo na recikliranje, se obrnite na pristojni organ, komunalno službo ali trgovino, kjer ste izdelek kupili.

Spanish notice

Eliminación de residuos de equipos eléctricos y electrónicos por parte de usuarios particulares en la Unión Europea



Este símbolo en el producto o en su envase indica que no debe eliminarse junto con los desperdicios generales de la casa. Es responsabilidad del usuario eliminar los residuos de este tipo depositándolos en un "punto limpio" para el reciclado de residuos eléctricos y electrónicos. La recogida y el reciclado selectivos de los residuos de aparatos eléctricos en el momento de su eliminación contribuirá a conservar los recursos naturales y a garantizar el reciclado de estos residuos de forma que se proteja el medio ambiente y la salud. Para obtener más información sobre los puntos de recogida de residuos eléctricos y electrónicos para reciclado, póngase en contacto con su ayuntamiento, con el servicio de eliminación de residuos domésticos o con el establecimiento en el que adquirió el producto.

Swedish notice

Bortskaffande av avfallsprodukter från användare i privathushåll inom Europeiska Unionen



Om den här symbolen visas på produkten eller förpackningen betyder det att produkten inte får slängas på samma ställe som hushållssopor. I stället är det ditt ansvar att bortskaffa avfallet genom att överlämna det till ett uppsamlingsställe avsett för återvinning av avfall från elektriska och elektroniska produkter. Separat insamling och återvinning av avfallet hjälper till att spara på våra naturresurser och gör att avfallet återvinns på ett sätt som skyddar människors hälsa och miljön. Kontakta ditt lokala kommunkontor, din närmsta återvinningsstation för hushållsavfall eller affären där du köpte produkten för att få mer information om var du kan lämna ditt avfall för återvinning.

B Electrostatic discharge

This appendix provides the following information:

- [How to prevent electrostatic discharge](#)
- [Grounding methods](#)

How to prevent electrostatic discharge

To prevent damage to the system, you must follow certain precautions when setting up the system or handling parts. A discharge of static electricity from a finger or other conductor may damage system boards or other static-sensitive devices. This type of damage may reduce the life expectancy of the device.

To prevent electrostatic damage, observe the following precautions:

- Avoid hand contact by transporting and storing products in static-safe containers.
- Keep electrostatic-sensitive parts in their containers until they arrive at static-free workstations.
- Place parts on a grounded surface before removing them from their containers.
- Avoid touching pins, leads, or circuitry.
- Always make sure you are properly grounded when touching a static-sensitive component or assembly.

Grounding methods

There are several methods for grounding. Use one or more of the following methods when handling or installing electrostatic-sensitive parts:

- Use a wrist strap connected by a ground cord to a grounded workstation or chassis. Wrist straps are flexible straps with a minimum of 1 megohm \pm 10 percent resistance in the ground cords. To provide proper ground, wear the strap snug against the skin.
- Use heel straps, toe straps, or boot straps at standing workstations. Wear the straps on both feet when standing on conductive floors or static-dissipating floor mats.
- Use conductive field service tools.
- Use a portable field service kit with a folding static-dissipating work mat.

If you do not have any of the suggested equipment for proper grounding, have an HP authorized reseller install the part.



NOTE:

For more information on static electricity, or for assistance with product installation, contact your HP authorized reseller.

C SAN Switch technical specifications

This appendix provides the following information:

- General specifications
- Weight and physical dimensions
- Environmental requirements
- Supported HBAs

General specifications

Table 15 lists general specifications for the 4Gb SAN Switch for HP c-Class BladeSystem.

Table 15 General specifications

Specification	Description
Configurable port types	F_Port, FL_Port, and E_Port
Media types	Small Form-Factor Pluggable (SFP) laser. 1/2/4Gb short wave up to 500 m (1,640 ft.) and 1/2/4Gb long wave up to 10 km
EMC emissions	An operating SAN Switch conforms to the emissions requirements specified by the following regulations: <ul style="list-style-type: none"> • FCC Rules & Regulations, Part 15 subpart B, Class A • CSA C108.8 Class A • VCCI Class A ITE • CISPR 22 Class A • EN55022 Class A • AS/NZF 3548: 1995 Class A • CNS13438 Class A • ICES-003 Class A • Korean EMC Requirements • BSMI Standard CNS 13438 • EMC Directive 89/336/EEC • EN5022 Level A • EN50082-2/EN55024: 1998
EMC immunity	<ul style="list-style-type: none"> • IEC 61000-4-2 Severity Level 3 for Electrostatic Discharge • IEC 61000-4-3 Severity Level 3 for Radiated Fields • IEC 61000-4-4 Severity Level 3 for Fast Transients • IEC 61000-4-5 Severity Level 3 for Surge Voltage • IEC 61000-4-6 Conducted Emissions • IEC 61000-4-11 Voltage Variations • EN 61000-4-12 Oscillatory Waves Immunity • EN 61000-3-2 Limits for Harmonic Current Emissions • EN 61000-3-3 JEIDA
System architecture	Nonblocking shared-memory switch
ANSI protocol	FC-PH (FC Physical and Signalling Interface standard)

Specification	Description
Modes of operation	FC Class 2, Class 3, and Class F
Maximum frame size	2112-byte
Port-to-port latency	1.2 μ sec. with no contention, cut-through routing at 4Gb. Latency increases as input port speed increases and becomes disparate from output port speed.

Weight and physical dimensions

Table 16 lists physical properties.

Table 16 4Gb SAN Switch physical dimensions

Dimension	Measurement
Height	29.3 mm (1.15 in)
Width	208 mm (8.19 in)
Depth	280 mm (11.02 in)
Weight	1.27 kg (2.8 lb)

Environmental requirements

To ensure proper operation, the switch must not be subjected to environmental conditions beyond those for which it was tested. The ranges specified in Table 17 list the acceptable environment for both operating and non-operating conditions.

Table 17 Environmental requirements

Condition	Acceptable range during operation	Acceptable range during non-operation
Ambient temperature	104°F/40 °C at sea level, derated 1 C per 1000 ft above sea level	-40°C to 70°C with maximum rate of change of 20 C /hr
Humidity	5% to 90% relative humidity, non-condensing	50% to 80% relative humidity, non-condensing
Altitude	0 to 10,000 ft (3 km) above sea level	0 to 40,000 ft (12 km) above sea level
Shock	40 G, 2mS duration	140 G, 2mS,
Vibration	0.5 G, 10–500 Hz	2.0 G, 5–500 Hz
Airflow	47 cubic ft/minute	None required

Supported SFPs

Do not use unsupported SFPs; they can affect switch operability. They may not fit correctly and may void your warranty. See [Optional hardware kits](#) for a list of supported SFPs.

For a complete list of supported devices, refer to the latest version of the *HP StorageWorks SAN design reference guide*: <http://h18000.www1.hp.com/products/storageworks/san/documentation.html>.

Supported HBAs

For a list of HBAs that have been tested and are known to work with the SAN switches, refer to the latest version of the *HP StorageWorks SAN design reference guide*: <http://h18000.www1.hp.com/products/storageworks/san/documentation.html>.

Glossary

This glossary defines terms used in this guide or related to this product. It is not a comprehensive glossary of computer terms.

AL_PA	Arbitrated loop physical address. A unique 8-bit value assigned during loop initialization to a port in an arbitrated loop. <i>See also</i> non-participating mode .
alias server	A fabric software facility that supports multicast group management.
API	Application programming interface. A defined protocol that allows applications to interface with a set of services.
arbitrated loop	A shared 100 Mb/s Fibre Channel transport structured as a loop. Can support up to 126 devices and one fabric attachment. <i>See also</i> public device , public loop .
AW_TOV	Arbitration wait time-out value. The minimum time an arbitrating L_Port waits for a response before beginning loop initialization.
backup FCS switch	Backup fabric configuration server switch. The switch or switches assigned as backup in case the primary FCS switch fails.
bandwidth	The total transmission capacity of a cable, link, or system. Usually measured in bits per second (b/s). May also refer to the range of transmission frequencies available to a link or system.
broadcast	The transmission of data from a single source to all devices in the fabric, regardless of zoning.
buffer-to-buffer flow control	Management of the frame transmission rate in either a point-to-point topology or an arbitrated loop. <i>See also</i> arbitrated loop , point-to-point , topology .
CLI	Command line interface. Interface that depends entirely on the use of commands, such as through telnet or SNMP, and does not involve a GUI.
compact flash	Flash (temporary) memory that is used in a manner similar to hard disk storage. It is connected to a bridging component that

	connects to the PCI bus of the processor. Not visible within the processor's memory space.
configuration	The way a system is set up. May refer to hardware or software: <ul style="list-style-type: none"> • Hardware: The number, type, and arrangement of components that make up a system or network. • Software: The set of parameters that guide switch operation. May include general system parameters, IP address information, domain ID, and other information. Modifiable by any login with administrative privileges. May also refer to a set of zones.
CRC	Cyclic redundancy check. A check for transmission errors that is included in every data frame.
data word	A type of transmission word that occurs within frames. The frame header, data field, and CRC all consist of data words.
defined zone configuration	The set of all zone objects defined in the fabric. May include multiple zone configurations. See <i>also</i> zone , zone configuration .
directory service	See SNS .
DLS	Dynamic load sharing. Dynamic distribution of traffic over available paths. Allows for recomputing of routes when an Fx_Port or E_Port changes status.
domain ID	Unique identifier used in routing frames for all switches in a fabric. Usually assigned by the principal switch, but can be assigned manually. The domain ID for an HP switch can be any integer between 1 and 239. The default domain ID is usually 1.
E_D_TOV	Error-detect time-out value. The minimum time a target waits for a sequence to complete before initiating recovery. Can also be defined as the maximum time allowed for a round-trip transmission before an error condition is declared.
E_Port	Expansion port. A type of switch port that can be connected to an E_Port on another switch to create an ISL. See <i>also</i> ISL trunking , U_Port .
EE_Credit	End-to-end credit. The number of receive buffers allocated by a recipient port to an originating port. Used by Class 1 and Class 2 services to manage the exchange of frames across the fabric between source and destination.
EIA rack	A storage rack that meets the standards set by the Electronics Industry Association (EIA).

enabled zone configuration	The currently enabled configuration of zones. Only one configuration can be enabled at a time. See also zone , zone configuration .
end-to-end flow control	A facility that governs flow of class 1 and class 2 frames between N_Ports.
error	With respect to FC, a missing or corrupted frame, time-out, loss of synchronization, or loss of signal (link error).
exchange	The highest-level FC mechanism used for communication between N_Ports. Composed of one or more related sequences; can work in one or both directions.
F_Port	Fabric port. A port that is able to transmit under fabric protocol and interface over links. Can be used to connect an N_Port to a switch. See also U_Port .
fabric	An FC network containing two or more switches in addition to hosts and devices. May also be called a <i>switched fabric</i> .
fabric name	The unique identifier assigned to a fabric and communicated during login and port discovery.
FCIA	Fibre Channel Industry Association. An international organization of FC industry professionals. Among other things, provides oversight of ANSI and industry standards.
FCP	Fibre Channel Protocol. Mapping of protocols onto the FC standard protocols. For example, SCSI FCP maps SCSI-3 onto FC.
FCS switch	Fabric Configuration Server switch. One or more designated HP switches that store and manage the configuration and security parameters for all switches in the fabric.
Fibre Channel	The primary protocol for building SANs to transmit data between servers, switches, and storage devices. Unlike IP and Ethernet, Fibre Channel is designed to support the needs of storage devices of all types. It is a high-speed, serial, bidirectional, topology-independent protocol, and is a highly scalable interconnection between computers, peripherals, and networks.
fill word	An IDLE or ARB ordered set that is transmitted during breaks between data frames to keep the link active.
FLOGI	The process by which an N_Port determines whether a fabric is present and, if so, exchanges service parameters with it. See also PLOGI .

FL_Port	Fabric loop port. A port that is able to transmit under fabric protocol and has arbitrated loop capabilities. Can also be used to connect an NL_Port to a switch. See also U_Port .
frame	The Fibre Channel structure used to transmit data between ports. Consists of a start-of-frame delimiter, header, optional headers, data payload, cyclic redundancy check, and end-of-frame delimiter. There are two types of frames: <i>link control frames</i> and <i>data frames</i> . See also packet .
FRU	Field-replaceable unit. A component that can be replaced on site.
FS	Fibre Channel Service. A service that is defined by FC standards and exists at a well-known address. The Simple Name Server, for example, is an FC service.
FSP	Fibre Channel Service Protocol. The common protocol for all fabric services; it is transparent to the fabric type or topology.
FSPF	Fabric shortest path first. HP routing protocol for FC switches.
Fx_Port	A fabric port that can operate as an F_Port or FL_Port.
G_Port	Generic port. A port that can operate as an E_Port or F_Port. A port is defined as a G_Port when it is not yet connected or has not yet assumed a specific function in the fabric. See also E_port , F_port , U_Port .
hard address	The AL_PA that an NL_Port attempts to acquire during loop initialization. See also defined zone configuration .
idle	Continuous transmission of an ordered set over an FC link when no data is being transmitted, to keep the link active and maintain bit, byte, and word synchronization.
integrated fabric	The fabric created by connecting multiple HP switches with multiple ISL cables, and configuring the switches to handle traffic as a seamless group.
ISL trunking	The distribution of traffic over the combined bandwidth of multiple ISLs. A set of trunked ISLs is called a <i>trunking group</i> ; the ports in a trunking group are called <i>trunking ports</i> .
isolated E_Port	An E_Port that is online but not operational due to overlapping domain IDs or nonidentical parameters (such as E_D_TOVs). See also E_D_TOV .

K28.5	A special 10-bit character that indicates the beginning of a transmission word that performs FC control and signaling functions. The first seven bits are the common pattern.
kernel flash	Flash (temporary) memory connected to the peripheral bus of the processor and visible within the processor's memory space. Also called a <i>user flash</i> .
L_Port	<p>Loop port. A node port (NL_Port) or fabric port (FL_Port) that has arbitrated loop capabilities. An L_Port can be in one of two modes:</p> <ul style="list-style-type: none"> • Fabric mode: Connected to a port that is not loop capable and is using fabric protocol. • Loop mode: In an arbitrated loop and using loop protocol. An L_Port in loop mode can also be in <i>participating mode</i> or <i>non-participating mode</i>. <p>See also non-participating mode.</p>
latency	The time required to transmit a frame from the time it is sent until it arrives. Together, latency and bandwidth define the speed and capacity of a link or system.
link	With respect to FC, a physical connection between two ports, consisting of both transmit and receive fibers.
link services	A protocol for link-related actions.
LIP	Loop initialization primitive. The signal that begins initialization in a loop. It indicates either loop failure or the resetting of a node.
LM_TOV	Loop master time-out value. The minimum time that the loop master waits for a loop initialization sequence to return.
loop failure	Loss of signal within a loop for any period of time; loss of synchronization for longer than the time-out value.
Loop_ID	A hexadecimal value representing one of the 127 possible AL_PA values in an arbitrated loop. See also AL_PA .
loop initialization	The logical procedure used by an L_Port to discover its environment. Can be used to assign AL_PA addresses, detect loop failure, or reset a node. See also AL_PA .
LPSM	Loop port state machine. The logical entity that performs arbitrated loop protocols and defines the behavior of L_Ports when they require access to an arbitrated loop. See also L_Port .

LWL	Long wavelength. A type of fiber optic cabling that is based on 1300 nm lasers and supports link speeds up to 2 Gb/s. May also refer to the type of transceiver. See also SWL .
master port	The port that determines the routing paths for all traffic flowing through a trunking group. One of the ports in the first ISL in the trunking group is designated as the master port for that group. See also ISL trunking .
MIB	Management Information Base. An SNMP structure to help with device management, providing configuration and device information. See also SNMP .
multicast	The transmission of data from a single source to multiple specified N_Ports (as opposed to all ports on the network).
N_Port	Node port. A port on a node that can connect to an FC port or to another N_Port in a point-to-point connection.
name server	A term frequently used to indicate a Simple Name Server (SNS). See also SNS .
NL_Port	Node loop port. A node port that has arbitrated loop capabilities. Used to connect an equipment port to the fabric in a loop configuration through an FL_Port. See also node .
node	An FC device that contains an N_Port or NL_Port.
non-participating mode	A mode in which an L_Port in a loop is inactive and cannot arbitrate or send frames, but can retransmit any received transmissions. This mode is entered if there are more than 127 devices in a loop and an AL_PA cannot be acquired. See also L_Port , AL_PA .
Nx_Port	A node port that can operate as an N_Port or NL_Port.
Onboard Administrator (OA)	The HP BladeSystem Onboard Administrator (OA) is the enclosure management processor, subsystem, and firmware base used to support the HP BladeSystem c7000 or HP BladeSystem c3000 and all the managed devices contained within the enclosure.
packet	A set of information transmitted across a network.
participating mode	A mode in which an L_Port in a loop has a valid AL_PA and can arbitrate, send frames, and retransmit received transmissions.
path selection	The selection of a transmission path through the fabric. HP switches use the FSPF protocol for transmission path selection.

phantom address	An AL_PA value assigned to a device that is not physically in the loop. Also known as <i>phantom AL_PA</i> . See also AL_PA , phantom device .
phantom device	A device that is not physically in an arbitrated loop but is logically included through the use of a phantom address. See also phantom address .
PLOGI	Port login. The port-to-port login process by which initiators establish sessions with targets. See also FLOGI .
point-to-point	An FC topology that employs direct links between each pair of communicating entities. See also buffer-to-buffer flow control .
port cage	The metal casing extending out of the FC port on the switch and into which a GBIC or SFP transceiver can be inserted.
Port_Name	The unique identifier assigned to an FC port. It is communicated during login and port discovery.
POST	Power-on self-test. A series of diagnostic tests run by a switch after it is powered on.
primary FCS switch	Primary Fabric Configuration Server switch. The switch that actively manages the configuration and security parameters for all switches in the fabric.
private loop	An arbitrated loop that does not include a participating FL_Port.
private NL_Port	An NL_Port that communicates only with other private NL_Ports in the same loop and does not log in to the fabric.
public device	A device that supports arbitrated loop protocol, can interpret 8-bit addresses, and can log in to the fabric. See also arbitrated loop .
public loop	An arbitrated loop that includes a participating FL_Port and may contain both public and private NL_Ports. See also arbitrated loop .
public NL_Port	An NL_Port that logs in to the fabric, can function within a public or private loop, and can communicate with private or public NL_Ports. See also private loop .
quad	A group of four adjacent ports that share a common pool of frame buffers.
R_A_TOV	Resource allocation time-out value. The maximum time a frame can be delayed in the fabric and still be delivered.

RAID	Redundant Array of Independent Disks. A collection of disk drives that appear as a single volume to the server and are fault tolerant through mirroring or parity checking.
request rate	The rate at which requests arrive at a servicing entity.
route	With respect to a fabric, the communication path between two switches. May also apply to the specific path taken by an individual frame from source to destination.
routing	The assignment of frames to specific switch ports according to frame destination.
RR_TOV	Resource recovery time-out value. The minimum time a target device in a loop waits after a LIP before logging out a SCSI initiator.
RSCN	Registered state change notification. A switch function that allows notification of fabric changes to be sent from the switch to the specified nodes.
SAN	Storage area network. A network of systems and storage devices that communicate using FC protocols.
SDRAM	Synchronous dynamic random access memory. The main memory for a switch. See also switch .
sequence	A group of related frames transmitted in the same direction between two N_ports.
service rate	The rate at which an entity can service requests.
single mode	The fiber optic cabling standard that corresponds to distances up to 10 km between devices.
SNMP	Simple Network Management Protocol. An Internet management protocol that uses either IP for network-level functions and UDP for transport functions, or TCP/IP for both. SNMP can be made available over other protocols (such as UDP/IP) because it does not rely on the underlying communication protocols. See also MIB , trap (SNMP) .
SNS	Simple Name Server. A switch service that stores names, addresses, and attributes for up to 15 minutes, and provides them as required to other devices in the fabric. May also be referred to as a <i>directory service</i> .
switch	Hardware that routes frames according to FC protocol and is controlled by software.

switch port	A port on a switch. Switch ports can be E_Ports, F_Ports, or FL_Ports.
SWL	Short wavelength. A type of fiber optic cabling that is based on 850 nm lasers and supports link speeds up to 2 Gb/s. May also refer to the type of transceiver.
tenancy	The time span that begins when a port wins arbitration in a loop and ends when the same port returns to the monitoring state. Also called <i>loop tenancy</i> .
throughput	The rate of data flow achieved within a cable, link, or system. Usually measured in bits per second (b/s).
topology	With respect to FC, the configuration of the FC network and the resulting communication paths allowed. There are three possible topologies: <ul style="list-style-type: none"> • Point-to-point: A direct link between two communication ports • Switched fabric: Multiple N_Ports linked to a switch by F_Ports • Arbitrated loop: Multiple NL_Ports connected in a loop
transmission character	A 10-bit character encoded according to the rules of the 8b/10b algorithm.
transmission word	A group of transmission characters.
trap (SNMP)	The message sent by an SNMP agent to inform the SNMP management station of a critical error. See also SNMP .
U_Port	Universal port. A switch port that can operate as a G_Port, E_Port, F_Port, or FL_Port. A port is defined as a U_Port when it is not connected or has not yet assumed a specific function in the fabric. See also E_port , F_port , G_Port .
well-known address	With respect to FC, a logical address defined by the FC standards as assigned to a specific function and stored on the switch.
workstation	A computer used to access and manage the fabric. May also be called a <i>management station</i> or <i>host</i> .
WWN	World wide name. An identifier that is unique worldwide. Each entity in a fabric has a distinct WWN.
zone	A set of devices and hosts attached to the same fabric and configured as being in the same zone. Devices and hosts

within the same zone have access permission to others in the zone, but are not visible to any outside the zone. See *also* [defined zone configuration](#), [enabled zone configuration](#).

zone configuration A specified set of zones. Enabling a configuration enables all zones in that configuration. See *also* [defined zone configuration](#), [enabled zone configuration](#).

Index

A

advanced performance monitoring, 19
advanced web tools, 42
advanced zoning, 19
audience, 9

B

boot, 49
boot specifications, 49

C

command line interface, 42
conventions
 document, 11
 text symbols, 11

D

diagnostics, 44
document
 conventions, 11
 related documentation, 9, 9

E

EIA, 22
environmental requirements, 76
Ethernet connection, 32
extended fabrics, 19

F

fabric license
 base, 18
 full, 18
 Power Pack, 18
fabric licenses, 18

Fabric Watch, 19
Fibre Channel
 FC domain ID, 35

G

general specifications, 74
grounding methods, 71

H

hardware kits, 20
HBAs, supported, 76
help
 obtaining, 10
HP
 storage web site, 12
 Subscriber's choice web site, 12
 technical support, 10

I

IP address, 24, 31
ISL
 trunking groups, 19

L

LED
 interpreting activity, 45
 location, 46
 patterns, 47
LED patterns, 47
licenseshow, 34
long wavelength, see LWL, 14

M

management station, 42

O

optional, 20
optional hardware kits, 20

P

port
 configurable types, 14
 speed, 14
port LED patterns, 48
POST, 49
POST results, 50
POST specifications, 49
Power Pack, 18

R

related documentation, 9, 9

S

SAN Switch
 configuration, 31
 installing, 24
 licensing, 18
 maintenance, 43
 management features, 41
 port diagram, 16
 power, 45

SFP transceiver, 31
 removing, 43
SFP transceivers
 supported, 76
shipping carton contents, 21
SNMP applications, 42
specifications
 environmental requirements, 76
 general, 74
 physical, 75
Subscriber's choice, HP, 12
supported HBAs, 76
supported SFPs, 76
symbols in text, 11

T

technical support
 HP, 10
text symbols, 11
transceiver, 14, 16, 31, 44, 47, 48

W

web sites
 HP documentation, 12
 HP storage, 12
 HP Subscriber's choice, 12
web tools, 19