

MR164 Keypad Operating Instructions



Congratulations and thank you for choosing this Knoll product. The MR164 keypads can control the GSZ67 controller-amplifiers. They are very easy-to-use giving you top quality sound available in up to six or more rooms.

The MR164 is available with two LCD colors, yellow-green with black lettering and blue with white lettering (model MR164b). Both versions are available with Decora™ style bezel plates in white, almond, black or ivory colors.

The music system consists of:

1. Rooms with stereo speakers, a MR164 keypad or a third party whole house controller and possibly a remote control.
2. One or more GSZ67 controller-amplifiers.
3. Stereo source components such as tuners, CD players, satellite dish receivers, cassette decks, and other components.

While the MR164 evolved after years of research, its use is straightforward and direct. Some rooms may have more than one pair of speakers and one or two MR164 keypads or possibly even no keypad.

The music system is controlled by the MR164 keypads, RB12 or universal remote, the source components and possibly a whole home controller. The source components are controlled by their individual remote controls by aiming the remote control at the keypad or infrared receiver and pressing the appropriate remote control button.

Please read about the GSZ67 with the manual shipped with that product.

MR164 Keypad Operation

The MR164 keypad is relatively easy to operate and within a short period of time should be very intuitive.

Please ensure that keys are not pressed too fast as the controller or keypad may be confused. If this happens reset the system powering it off and then on again.

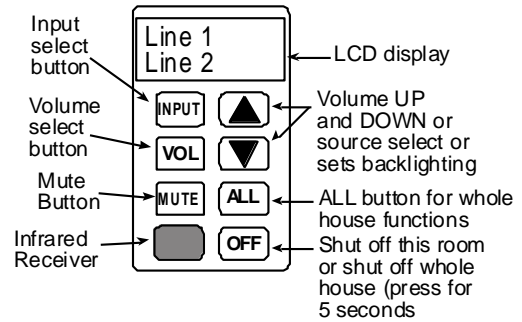

Adjusting Backlighting. MR164's are backlit for easy nighttime operation. To adjust the backlighting make sure the power for the keypad is on and the MR164 is displaying:



Without pressing any other buttons press the UP or DOWN button to increase or decrease the backlighting illumination. The level selected will remain in the memory even if the power is disconnected.

Turning on a source to this room with the MR164 keypad. After the system is completely installed, if the system is not yet turned on, turn the sources on and then turn the GSZ67 controller amplifier using the front power button on the GSZ67.

After power has been turned on the MR164 keypad will display its software revision followed by "Knoll Systems" and then:



To turn a source on in this room press the **INPUT** button. The volume is always set at about 30% when the room speakers are first turned on. This room will always revert to the source it was switched to when it was turned off last time. To change to another source, see changing sources below.

Turn on a source in this room using the RB12 Remote Control. To turn on a source in this room using the RB12 remote control press the RB12 remote control 1, to 7 button corresponding to which source you want to listen to. You do not need to press the **POWER** button on the remote first.

Whole house source selection is not available from the RB12 remote.

Changing Sources. To change to another source press and release the MR164 keypad **INPUT** button followed by the **UP** or **DOWN** button to scroll through the four sources until the desired source is displayed on the MR164 display. The amplifier for this room will then switch to this source.

To change sources in this room only from the RB12 remote control simply press the 1 to 7 button to directly go to the desired source.

Volume Up and Down: To adjust the volume up or down (always) first press the MR164 **VOL** button then quickly press the **UP** or **DOWN** button until the desired changed volume level is reached on the MR164. Holding the button gives continuous changes. After the **UP** or **DOWN** button has been released the MR164 keypad may display the current relative volume setting of low, mid, high etc.

To change the volume using the RB12 remote press the **UP** or **DOWN** button until the desired changed volume level is reached on the MR164. Holding the button gives continuous changes. After the **UP** or **DOWN** button has been released the MR164 keypad may display the current relative volume setting of low, mid high etc.

Mute: Momentarily press the MR164 keypad or RB12 remote **MUTE** button. The LCD display will display:



To restore the sound press the **MUTE, UP** or **DOWN** button on the MR164 keypad or RB12 remote and the source selected when the mute button was first pressed and the former volume level is restored.

Turn Room Off: Momentarily press the MR164 keypad **OFF** button or RB12 remote **POWER** button. The MR164 will display:



If any other room was turned on, only this room will shut off and other rooms will not be affected. If this was the only room turned on since the system was first turned on, then the whole system will shut off and the MR164 will display a few seconds later:



Sources may have to be turned off manually or by remote.

ALL System Commands

The **ALL** button is used to change the whole house volume (only for rooms already turned on), select one source for all rooms or turn all rooms off. All commands are from the MR164 keypads only and cannot be done from the remote control.

◆To change all rooms to the same source, this room must be listening to a source first. Press the **ALL** button, quickly press the **INPUT** button then the **UP** or **DOWN** button until the desired source is displayed on the LCD display. All of the rooms will be now be playing that source at about 30% volume.



Note: Be very careful when turning up the whole house volume. The volume levels increase together, but rooms with their volume already set high may damage equipment when their volume is increased.

◆To change the whole house volume, this room must be listening to a source first. Press the **ALL** button, quickly press the **VOL** button then the **UP** or **DOWN** button until the desired volume in all rooms is achieved. Please note all rooms will not necessarily be at the same volume as some may have initially been at a higher or lower volume and had the volume changed from that point. The whole house volume changes more gradually than when changing individual room volumes.

◆To turn the whole home system off (except for sources), press the **ALL** button then quickly press the **OFF** button. The whole system will start its turn off procedure. The LCD keypad will display:



Another way to achieve turning the whole system off is to press the MR164 **OFF** button for about 5 seconds. To turn the whole home system off from the RB12 remote control, press the **POWER** button for about 5 seconds. The MR164 keypad will then display:



RB12 Remote Layout

