

Countertop Rotisserie Oven

MODEL FS

Installation & Operation Manual

Serial Numbers 122912 and Higher



Warranty Information

LIMITED ONE YEAR WARRANTY

BKI (The "Company") warrants to the original purchaser that at time of shipment from the Company factory, this equipment will be free from defect in materials and workmanship. Written notice of a claim under this warranty must be received by the Company within ONE YEAR from the date of installation, but no longer than ONE YEAR AND THREE MONTHS from date of shipment from the factory. Defective conditions caused by abnormal use or misuse, lack of or improper maintenance, damage by third parties, alterations by unauthorized personnel, acts of God, failure to follow installation and/or operating instructions, or any other events beyond the reasonable control of the Company will NOT be covered under this warranty. The obligation of the Company under this warranty shall be limited to repairing or replacing (at the option of the Company) any part, with the exception of lamps, fuses, and glass (which are not covered under warranty), which is found defective in the reasonable opinion of the Company. Any part found defective by the Company will be repaired or replaced without charge F.O.B. factory, Simpsonville, South Carolina or F.O.B. authorized BKI Distributor. The Company and/or its authorized representatives will assume the normal replacement labor expense for the defective part for the period of the warranty as stated above, excluding travel and/or other expenses incidental to the replacement of the defective part, where replacement work is performed during standard business hours and not subject to overtime, holiday rates, and/or any additional fees. IN NO EVENT SHALL THE COMPANY BE LIABLE FOR LOSS OF USE, LOSS OF REVENUE OR LOSS OF PRODUCT OR PROFIT OR FOR INDIRECT OR CONSEQUENTIAL DAMAGES INCLUDING BUT NOT LIMITED TO, FOOD SPOILAGE OR PRODUCT LOSS. WARRANTY DOES NOT COVER GLASS BREAKAGE. THE ABOVE WARRANTY IS EXCLUSIVE AND ALL OTHER WARRANTIES, EXPRESS OR IMPLIED, ARE EXCLUDED INCLUDING THE IMPLIED WARRANTIES OF MERCHANTABILITY AND FITNESS FOR A PARTICULAR PURPOSE.

REPLACEMENT PARTS

Any appliance replacement part, with the exception of lamps, fuses, and glass, which proves to be defective in material or workmanship within ninety (90) days of installation will be replaced without charge F.O.B. Factory, Simpsonville, SC or F.O.B. authorized BKI Distributor. The user shall have the responsibility and expense of removing and returning the defective part to the Company as well as the cost of reinstalling the replacement or repaired part.

Table of Contents

Table of Contents	1
Introduction	2
Safety Precautions	2
Safety Signs and Messages	2
Safe Work Practices	3
Health And Sanitation Practices.....	4
Food Handling.....	4
Storage Of Raw Meats.....	4
Coding Cooked Foods	4
Storage Of Prepared Foods.....	4
Safety Labels.....	5
Operation	6
Controls and Indicators	6
Controller Operation	8
Modes	8
Programming.....	9
Cooking	9
Power Failure During Cooking Cycle	10
Probe (Thermocouple) Diagnostics.....	10
Installation	11
Unpacking and Handling	11
Location and Clearance	11
Wiring	11
Maintenance	12
Scheduled Maintenance.....	12
Oven Cleaning	12
Troubleshooting.....	13

Introduction

The FS is single revolving mild air convection countertop oven. It utilizes a single revolving rotor system to ensure even product cooking. The unit contains a single stage cook and hold computer with 5 customizable cook programs. Electronic controls are provided for powering the unit, turning on inside lights, turning the rotors and resetting the unit. The rotors are removable to allow for easy maintenance and cleaning.

The **BKI** name and trademark on this unit assures you of the finest in design and engineering -- that it has been built with care and dedication -- using the best materials available. Attention to the operating instructions regarding proper installation, operation, and maintenance will result in long lasting dependability to ensure the highest profitable return on your investment.

NOTICE

PLEASE READ THIS ENTIRE MANUAL BEFORE OPERATING THE UNIT. If you have any questions, please contact your **BKI** Distributor. If they are unable to answer your questions, contact the **BKI** Technical Service Department, toll free: 1-800-927-6887. Outside the U.S., call 1-864-963-3471.

Safety Precautions

Always follow recommended safety precautions listed in this manual. Below is the safety alert symbol. When you see this symbol on your equipment, be alert to the potential for personal injury or property damage.



Safety Signs and Messages

The following Safety signs and messages are placed in this manual to provide instructions and identify specific areas where potential hazards exist and special precautions should be taken. Know and understand the meaning of these instructions, signs, and messages. Damage to the equipment, death or serious injury to you or other persons may result if these messages are not followed.

DANGER

This message indicates an imminently hazardous situation which, if not avoided, will result in death or serious injury.

WARNING

This message indicates a potentially hazardous situation, which, if not avoided, could result in death or serious injury.

CAUTION

This message indicates a potentially hazardous situation, which, if not avoided, may result in minor or moderate injury. It may also be used to alert against unsafe practices.

NOTICE

This message is used when special information, instructions or identification are required relating to procedures, equipment, tools, capacities and other special data.

Safe Work Practices



Wear Safe Clothing Appropriate To Your Job

Always wear your insulated mitts when handling hot racks or touch any hot metal surface. If you lose or damage your mitts, you can buy new ones at your local restaurant equipment supply store or from your local **BKI** Distributor.

Always wear non-skid shoes when working around the oven or any other equipment.

Never wear loose clothing such as neckties or scarves while operating this equipment. Keep loose hair tied back or in a hair net while operating this equipment.

Always wear appropriate personal protection equipment during the cleaning process to guard against possible injury from hot cleaning solution.



Beware of High Voltage

This equipment uses high voltage. Serious injury can occur if you or any untrained or unauthorized person installs, services, or repairs this equipment. Always Use an Authorized Service agent to Service Your Equipment.



Keep this manual with the Equipment

This manual is an important part of your equipment. Always keep it near for easy access. If you need to replace this manual, contact:

BKI

Technical Services Department
P.O. Box 80400
Simpsonville, S.C. 29680-0400
Or call toll free: 1-800-927-6887
Outside the U.S., call 864-963-3471



Protect Children

Keep children away from this equipment. Children may not understand that this equipment is dangerous for them and others.

NEVER allow children to play near or operate your equipment.



Keep Safety Labels Clean and in Good Condition

Do not remove or cover any safety labels on your equipment. Keep all safety labels clean and in good condition. Replace any damaged or missing safety labels. Refer to the Safety Labels section for illustration and location of safety labels on this unit. If you need a new safety label, obtain the number of the specific label illustrated on page 5, then contact:

BKI

Technical Services Department
P.O. Box 80400
Simpsonville, S.C. 29680-0400
Or call toll free: 1-800-927-6887
Outside the U.S., call 864-963-3471

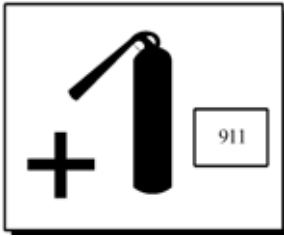

Be Prepared for Emergencies

Be prepared for fires, injuries, or other emergencies.

Keep a first aid kit and a fire extinguisher near the equipment. You must use a 40-pound Type BC fire extinguisher and keep it within 25 feet of your equipment.

Keep emergency numbers for doctors, ambulance services, hospitals, and the fire department near your telephone.



Know your responsibilities as an Employer

- Make certain your employees know how to operate the equipment.
- Make certain your employees are aware of the safety precautions on the equipment and in this manual.
- Make certain that you have thoroughly trained your employees about operating the equipment safely.
- Make certain the equipment is in proper working condition. If you make unauthorized modifications to the equipment, you will reduce the function and safety of the equipment.

Health And Sanitation Practices

BKI Rotisserie Ovens are manufactured to comply with health regulations and are tested and certified to NSF standards. You must operate the equipment properly, using only quality products and use meat thermometers to insure meats are thoroughly cooked.

Food Handling

- Wash hands thoroughly in warm, soapy water after handling raw poultry or meats.
- Clean and sanitize all utensils and surfaces that have been in contact with raw products. Clean and sanitize the meat forks or baskets between cooking.
- **Never** place cooked meats on the same surfaces used to prepare raw meats, unless the area has been thoroughly cleaned and sanitized.

Storage Of Raw Meats

- Designate an area or shelf strictly for the storage of all raw meats to be used in the rotisserie.
- Raw product must always be stored at temperatures below 38° F. (3° C.).
- **Never** store or mix raw foods above cooked foods, as this is a health hazard. The drippings from raw foods contaminate cooked or processed foods.
- All chicken and chicken parts to be stored overnight must be thoroughly iced down and refrigerated.

Coding Cooked Foods

All products cooked during the day should be sold the same day.

NOTE: It is not the intent of the rotisserie program to have unsold merchandise at the end of the cooking day. Follow your company's procedures for the handling of any leftover product.

Storage Of Prepared Foods

- Cold foods should be kept at or below 38° F. (3° C.).
- Hot foods must be maintained to meet local health codes, usually a minimum 145° F. (63° C.).

Safety Labels

N0202

	⚠ DANGER HIGH VOLTAGE. Turn power off before servicing. May have more than one disconnect switch. <small>Do not cover or remove label. N0202</small>
--	---

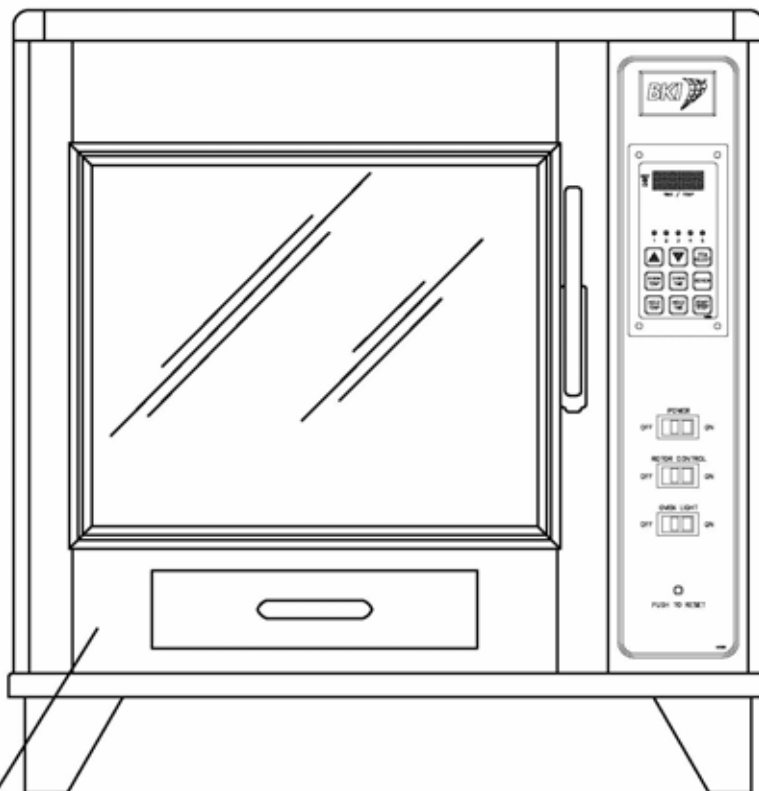

N0363

	NOTICE	
<p>This rotisserie oven has been equipped with removable rotors. By spinning the hubs counter-clockwise, the rotors can be easily removed for cleaning. Allow unit to cool to room temperature before cleaning.</p>		
<p>N0363</p>		

Operation

Controls and Indicators

Refer to the figure and table below for an explanation of the oven's controls and indicators.

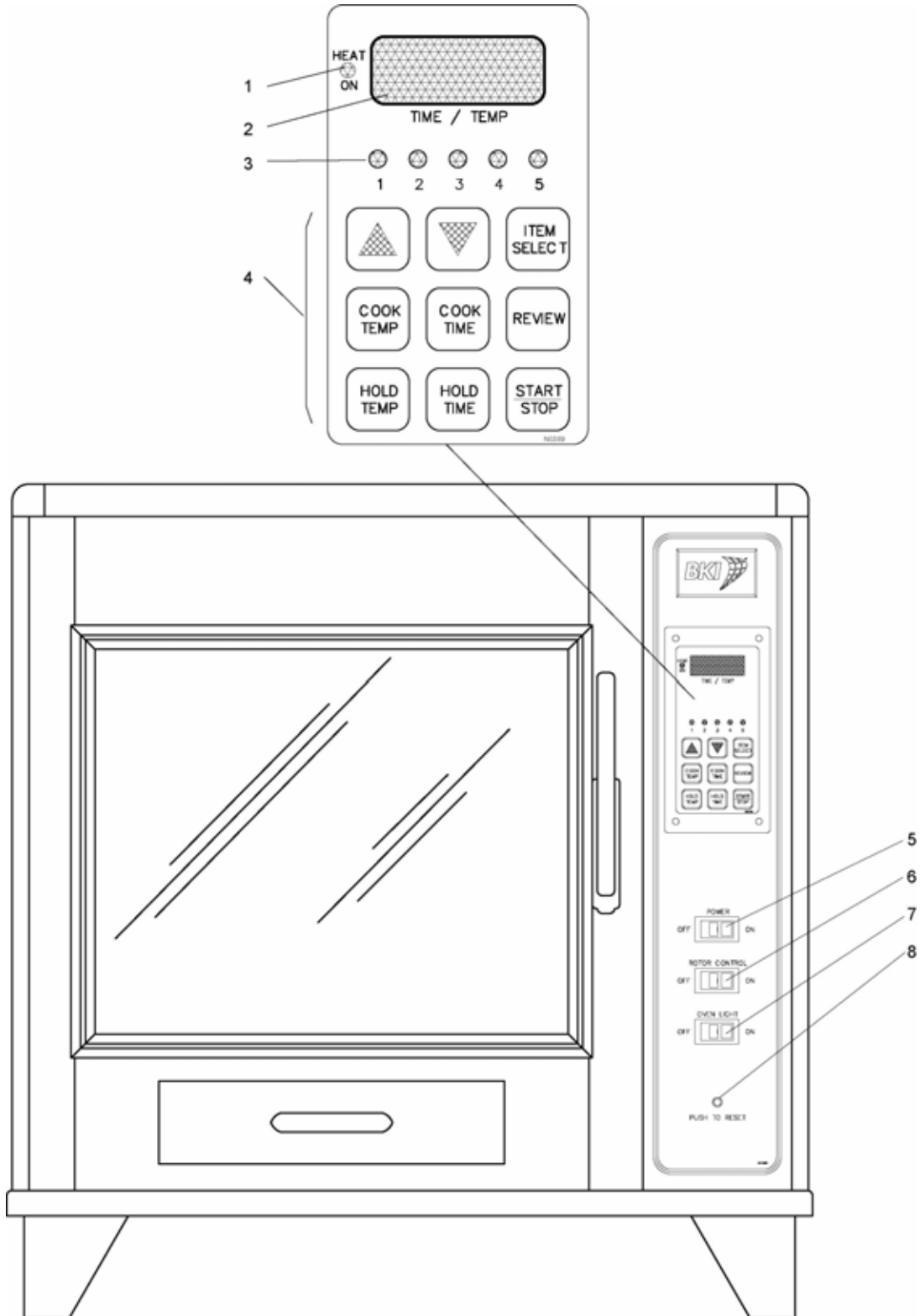

Item #	Description	Function
1	HEAT ON LED	Illuminates to indicate that the oven is calling for heat. It cuts off only when the temperature is reached.
2	TIME/TEMP Display	Shows time/temperature and other messages during operation.
3	Program LEDs (1-5)	Illuminates to represent the program selected.
4	Function Buttons	<p>ITEM SELECT - This button is used to select the program. When this button is pressed, the controller advances to the next program and its associated LED illuminates.</p> <p>START/STOP - This button is used to start and stop a cook or hold cycle.</p> <p>UP AND DOWN ARROWS - These buttons are used for setting time/temperature by incrementing or decrementing to the desired value. These buttons are used in conjunction with the COOK TEMP, COOK TIME, HOLD TEMP, and HOLD TIME buttons.</p> <p>COOK TEMP - This button is used to review and/or change the cook temperature for the individual program.</p> <p>COOK TIME - This button is used to review and/or change the cook time for the individual program.</p> <p>HOLD TEMP - This button is used to review and/or change the hold temperature for the individual program.</p> <p>HOLD TIME - This button is used to review and/or change the hold time for the individual program.</p> <p>REVIEW – This button is used to review and/or change a setting for any program.</p>
5	POWER ON/OFF Switch	Controls power to the entire unit.
6	ROTOR CONTROL ON/OFF Switch	Controls power to the motor that turns the rotors if the POWER switch is on.
7	OVEN LIGHTS ON/OFF Switch	Controls power to the lights inside oven if the POWER switch is on.
8	PUSH TO RESET Switch	Pressing this switch resets power to the rotor motor when the motor experiences an overload condition.

Controller Operation

The FS contains a single-stage cook and hold timer/temperature controller that has 5 cook programs and 5 modes of operation. This section explains the operating modes and programming of the controller.

Modes

Ready Mode

This mode is used to inform the operator that the oven temperature is at the initial temperature (*Ready Range*) for a particular program. Ready mode is entered following the initial warm-up period after power-up or when a new program is selected. In case of changing to a new program the oven may have to cool down or warm up to reach the initial oven temperature for the newly selected program. When the oven temperature enters the *Ready Range* for the current program, the display will flash “**rEdy**” and an audible alert will sound. At this time the display will alternate between the ready message and the current oven temperature. With the oven temperature in the *Ready Range*, a cycle may be started by pressing the **START/STOP** button.

Stop Mode

To enter the stop mode while a timing cycle is not in progress, press and hold the **START/STOP** button for one (1) second. The display will alternate between “**STOP**” and the oven temperature.

To enter the stop mode while a timing cycle is in progress, press and hold the **START/STOP** button for two (2) seconds. The controller will enter the ready mode after one (1) second. Continuing to hold the **START/STOP** button for an additional (1) second will put the controller in the stop mode.

To exit the stop mode, press the **START/STOP** button. If the oven temperature is in the *Ready Range*, the audible alert will sound. If the oven temperature is not in the *Ready Range*, the display will show the “**too Hot**” or **too Cool**” message as applicable. When the oven temperature again reaches the *Ready Range*, the audible alert will sound and the oven will be in the ready mode.

Cook Mode

The cook mode may be entered at any time. Press the **START/STOP** button to begin a programmed timed cycle. While timing the cooking cycle, the display will alternate between the time remaining and the actual temperature. When the time remaining reaches zero, the controller will alarm and flash the message “**donE**”.

If hold mode is disabled for this program, the unit will continue to alarm until the **START/STOP** button is pressed, which will then cancel the current cycle and the controller will enter the stop mode.

If hold mode is enabled, the audible alert will sound for five (5) seconds or until a button is pressed. The unit will then go into hold mode.

To cancel a cycle in progress, press and hold the **START/STOP** button for one (1) second. To restart a cycle with the same programs, press the **START/STOP** button.

Hold Mode

When the unit enters hold mode, the display will show “**HoLd**” for one (1) second, the accumulated time for two (2) seconds, and the oven temperature for one (1) second. The oven temperature will be regulated to the programmed hold temperature setting.

When the accumulated hold time reaches the hold time setting, the display will flash the message “**HoLd donE**” and alarm until a button is pressed. The control will now enter the stop mode. The hold cycle may be canceled by pressing the **START/STOP** button for one (1) second.

Review Mode

While a cycle is in progress, the operator may enter the review mode and review and/or change a setting for any program. This is done by momentarily pressing the **REVIEW** button, then pressing the **ITEM SELECT** button for the desired item program. The display will be blank, and the program LED will flash. The operator may then press the function button and review/change the setting. If a button is not pressed within five (5) seconds, the controller will exit review mode. The cycle will continue to count accordingly (up or down) while in review mode.

If a cycle is changed during a timed cook or hold cycle and the time is set for a value that is less than the elapsed time for the current cycle, the cycle will be completed when the review mode is exited.

If the cycle in progress goes into audible alert while in review mode, the controller will exit review mode and all changes will be canceled.

Programming

Setting a Program

1. Press the **ITEM SELECT** button to select the desired program (indicated by the illuminated LED).
2. Press and hold a function (**COOK TEMP, COOK TIME, HOLD TEMP, OR HOLD TIME**) button. The current setting will be displayed.
3. Press the **UP** or **DOWN** button as needed to display the required setting.
 - The hold mode may be disabled on any program individually. The timed cook cycle may also be disabled, and the controller will operate as a holding timer. This is done by setting the cook or hold time to "**OFF**".
 - The controller may also operate with the cook and/or hold temperature set to "**OFF**". When both the cook and hold temperature are set to "**OFF**", the controller will not regulate the oven temperature. This feature is intended for demonstration or display purposes.

Reviewing a Program

1. Press the **REVIEW** button. The display will be blank and a program LED will be flashing.
2. Press the **ITEM SELECT** button to display the flashing LED for the desired program.
3. Press and hold the desired function button. The current setting will be displayed.
4. To change the setting, press the **UP** or **DOWN** button while holding the function button.
 - If a button is not pressed within five (5) seconds, the controller will exit review mode and continue the cycle previously in progress.
 - The cycle in progress will continue to count up or down accordingly while in the review mode.
 - If a cycle is changed during a timed cook and/or hold cycle and the time is set for a value that is less than the elapsed time for the current cycle, the current cycle will be completed when the review mode is exited.
 - If the cycle in progress goes into audible alert while in review mode, the controller will exit review mode and all changes will be canceled.

Cooking

1. Place the **POWER** switch, **OVEN LIGHTS** switch, and **ROTOR CONTROL** switch located on the front panel in the "ON" position. The controller will automatically load the settings from the last program selected and begin regulating to the cook or hold temperature. Typically, the oven temperature is too cool upon power-up. If the oven temperature is below the programmed temperature, the display will alternately flash "**too**", "**Cool**" until the oven temperature reaches the programmed temperature.

2. Select the desired program by pressing the **ITEM SELECT** button until the LED corresponding to the desired program is illuminated.
3. When the controller reaches the programmed temperature, the display will alternate between "**rEdy**" and the current oven temperature. The audible alert will also sound for five (5) seconds. The audible alert may be canceled early by pressing the **START/STOP** button. The display will continue to flash the ready message.

During the ready message, the operator may also change to a new program. Since each program may be set for a different temperature, the controller may require a warm-up or cool-down period for the oven to get in range. If the oven temperature is out of range from the new setting, the display will show either "**too Hot-OPEn door**" or "**too Cool**", until the oven temperature comes within range of the new setting. The *ready* message will again be displayed.

Once the display shows "**rEdy**", if the oven temperature falls out of range again (due to the door opening to load product), the "**too Hot**" or "**too Cool**" message will not be displayed. The "**too Hot**" or "**too Cool**" messages are disabled during a cycle.

4. Open the oven door and load the product. Use the **ROTOR CONTROL** switch on the front panel to operate the rotor during loading.
5. Once the product is loaded, close the door.
6. When the display is flashing the ready message and you want to start the cook cycle, press the **START/STOP** button.
7. When a cook cycle ends, do one of the following:
 - If a hold time/temperature has not been programmed, an alarm will sound and the display will flash the message "**donE**" until a button is pressed. Press the **START/STOP** button to enter the stop mode.
 - If a hold time/temperature has been programmed, the hold cycle will start. During the hold cycle the oven temperature will be regulated to the programmed hold temperature setting. When the accumulated hold time reaches the hold time setting, an alarm sounds and the display will flash the message "**HoLd donE**" until a button is pressed. Press the **START/STOP** button to enter the *stop* mode.

Power Failure During Cooking Cycle

The controller will suspend operation retaining programs and cycle times. When power is restored, operation will resume where left off when power failed.

Probe (Thermocouple) Diagnostics

If the probe (thermocouple inside the oven) stops working, the controller will cancel the cooking cycle, an audible alert will sound, and the display will show "**PROB**".

Installation

⚠ WARNING

Serious injury, equipment damage or death could result if attempting to install this oven yourself. Ensure that an authorized BKI service agent installs the oven.

Unpacking and Handling

It is the owners' responsibility to file all freight claims with the delivering truck line. Inspect all cartons and crates for damage as soon as they arrive. If damage to cartons or crates is found, or if a shortage is found, note this on the bill of lading (all copies) prior to signing.

If damage is found when the equipment is opened, immediately call the delivering truck line and follow up the call with a written report indicating concealed damage to your shipment. Ask for an immediate inspection of your concealed damage item. Packaging material **MUST** be retained to show the inspector from the truck line.

Remove all packing from the interior and exterior of the oven.

Location and Clearance

Underwriters Laboratories requires that the oven have at least 6" clearance from combustible surfaces at the rear of the machine.

Wiring

⚠ WARNING

Electrocution, equipment failure or property damage could result if an unlicensed electrician performs the electrical installation. Ensure that a licensed electrician perform the electrical installation in accordance with local codes, or in the absence of local codes, with the National Electrical Code, ANSI NFPA 70-20XX.

This unit, when installed by an authorized BKI service agent, must be wired for use in accordance with all applicable local, state, and federal codes. For specific electrical requirements and connections refer to the wiring diagram attached to the unit or provided in the Service Manual.

Maintenance

⚠ CAUTION

Failure to comply with the maintenance below could result in a serious accident or equipment damage.

⚠ DANGER

Failure to remove power from this unit before performing maintenance may cause severe electrical shock. This unit may have more than one disconnect switch.

Scheduled Maintenance

Oven Cleaning

The oven must be cleaned at the end of each business day. Cleaning is not only necessary for sanitary reasons, but will increase sales appeal and maximize operating efficiency.

⚠ DANGER

Failure to remove power from this unit may cause severe electrical shock. This unit may have more than one disconnect switch.

⚠ CAUTION

Using abrasive cleaners may damage the cabinet finish. Use only a mild soap and water solution.

DO NOT USE OVEN CLEANER on this machine. Caustic cleaners can cause damage to the machine.

Never steam clean or get excess water in the interior of the cabinet as this can damage unit.

Always wear appropriate personal protection equipment during the cleaning process to guard against possible injury from hot cleaning solution.

1. Turn off all switches and controls.
2. Let the oven cool to room temperature.
3. Pull grease drawer out of oven and empty it's contents.
4. Clean grease drawer and tray area with hot soapy water.
5. Remove all food products from the unit. Remove meat forks, hanging baskets and rotors from the unit and place them in a large sink to soak in hot cleaning solution (**BKI Cleaner**).
6. Clean the outside and inside of the rotisserie oven with warm water, a sponge and an approved cleaner which is authorized for use on food surface areas.
7. Clean meat forks, hanging baskets and rotors with warm water, a sponge and BK Cleaner. Wipe dry with a clean cloth.
8. Reassemble the oven.

Troubleshooting

Problem	Cause	Possible Solution
Unit will not turn on.	Power to unit is not on. Problem with building power panel, circuit breaker or fuse.	Check circuit breaker or fuses at building power panel. If problem persists, contact an authorized electrician for corrective action.
	Power cord may not be plugged into outlet.	Plug cord into outlet.
	Blown fuse.	Contact an authorized BKI service agent for corrective action.
Not rotating.	Motor circuit breaker tripped.	Press the reset button. If problem persists, contact an authorized BKI service agent for corrective action.
	ROTOR switch may not be activated.	Make sure the ROTOR switch is on.
Rotor switch not functioning.	Defective switch.	Contact an authorized BKI service agent for corrective action.
Oven does not heat at all.	Improper program settings.	Check program settings.
	Heating elements not functioning.	Contact an authorized BKI service agent for corrective action.
	Bad relay.	Contact an authorized BKI service agent for corrective action.
	Doors may not be closed.	Close the doors.
Oven heats up slowly.	Improper line voltage.	Check incoming voltage. If problem persists, contact an authorized BKI service agent for corrective action.
	Heating element not functioning.	Contact an authorized BKI service agent for corrective action.
Lights are not working.	Light switch may not be on.	Turn the LIGHTS switch on. If problem persists contact an authorized BKI service agent for corrective action.
Controller displays "PROB".	Thermocouple connection is loose or thermocouple defective.	Contact an authorized BKI service agent for corrective action.
Controller displays faulty temperature readings above 400 degrees.	Defective controller, Defective heating elements or Defective thermocouple.	Contact an authorized BKI service agent for corrective action.



P.O. Box 80400, Simpsonville, S.C. 29680-0400, USA
<http://www.bkideas.com>

Made and printed in the U.S.A
LI0129/0407