

**Start
Here!**

Quick Start Guide Next Page...



FP106

LCD Display
Caller ID
Phonebook
Speakerphone
SMS Messaging

Quick Start Guide

Uniden®

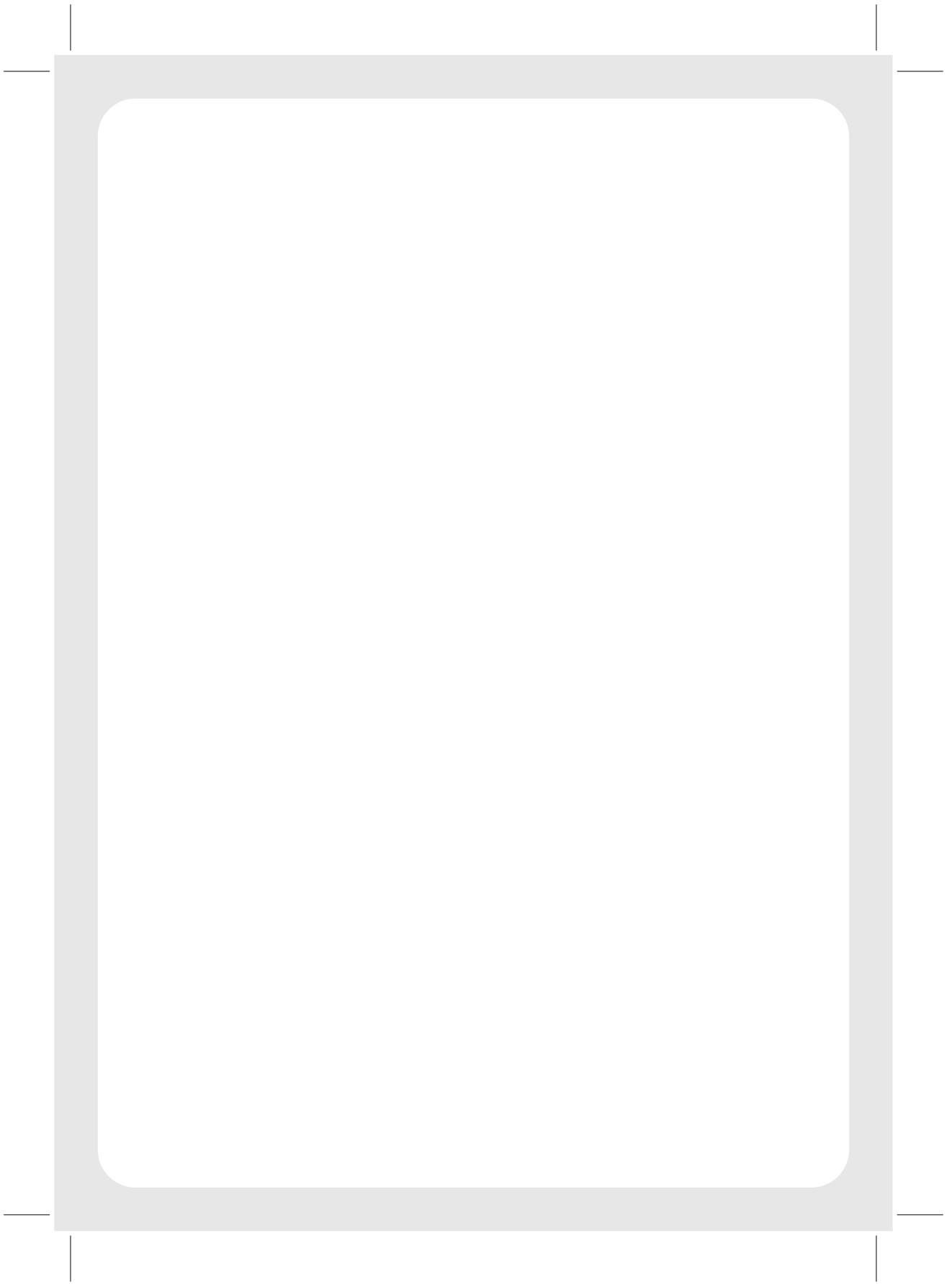

INSTALLATION & SAFETY

Choosing the best location for your phone.

When choosing a location for your phone there are a number of appliances the phone should not be near, and areas you should avoid.

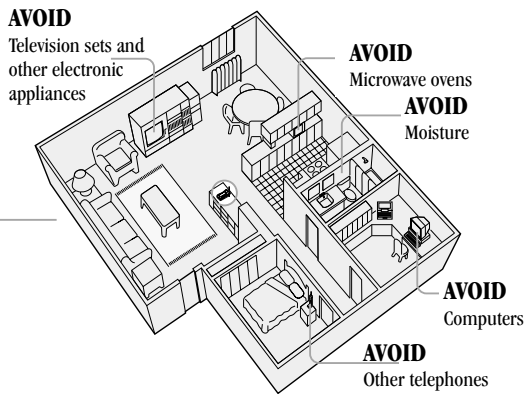

NOTE
This symbol indicates important operating and servicing instructions.

AVOID
Multi Power Boards

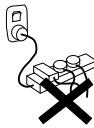

DON'T
Overload the power outlet

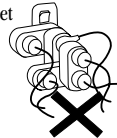

AVOID
Moisture

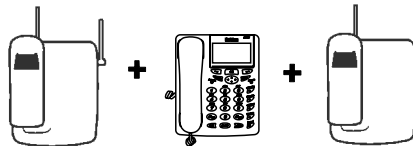

AVOID
Connecting more than
= 3
phones as ringing may be impaired

Start Here! 1 2 3

QUICK START GUIDE

This page is a very condensed version of the Owner's Manual. It is designed to allow you to get your phone installed and operating as quickly as possible -however it does not attempt to explain any of the advanced features of the FP106 series.

1 Installing the Base Unit

1) Connect the AC adapter to the DC IN 9V jack and to a standard AC wall outlet.

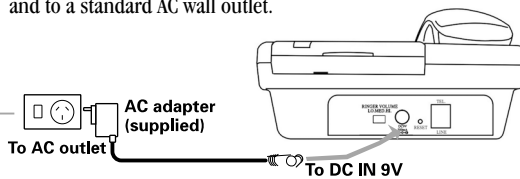

2) Connect the telephone line cord to the TEL LINE jack and to a telephone socket on the wall.

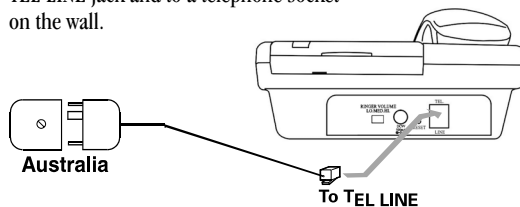

3) Set the base on a desk or tabletop.

4) For wall mounting, see "Mounting the Base Unit on a Wall" on page 9.

QUICK START GUIDE



Make sure the AC Adapter remains switched ON at all times. Use only the Uniden AC Adapter supplied with this unit.



During a power cut or if the AC adapter is switched off, this telephone will still function as a basic phone but without the speaker phone and display.

2 Handset Curly cord Connection

Plug one end of the Handset Curly Cord into the Handset and the other end into the jack on the side of the main base.

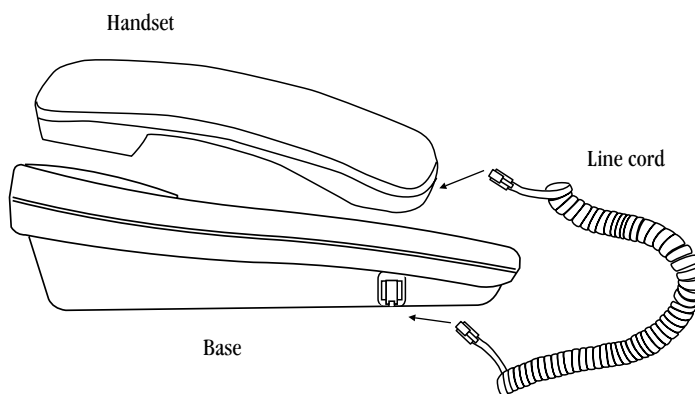

3 Using the Display, Scroll and the Soft keys

The FP106 has 3 soft key buttons,

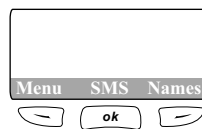

Options shown are an example only

Each soft key corresponds to the option displayed in the Display window above the keys.

If there is nothing displayed above the OK soft key then the OK button will respond as a confirmation button.

The FP106 also has Scroll keys which are used for selecting menus or options on the Display window. To use the Scroll keys press ▲ to move up a selection, press ▼ to move down a selection, press ◀ to move left or ▶ to move right.

Scroll Keys



4 Using Your Phone

1. To make a call:

Pick up handset or press 
Listen for the dial tone, then dial phone number.

Or for On Hook Dialling:

Dial the number first, then pick up handset or press 

2. To answer a call:

Pick up the handset to talk to the other party or press 
to use the speaker phone.

3. To end a call:

Place handset back into cradle of base unit or if using the
speaker phone press 

5 Using SMS Service

A subscription to an SMS service is required for SMS to function.

Setting SMS

To set the SMS alert ON so as to be alerted when an SMS is
received please refer to the instructions on page 22.

Sending an SMS

To send an SMS message please refer to the instructions on
page 23.

6 Setting the Clock

If you subscribe to Caller ID the time & date will be set automatically with the first incoming call.
Or see 'Clock' on page 25 for manual instructions.

7 Storing Numbers

For storing phone numbers into memory please see 'Storing a Name with phone numbers' page 16.

End of

Quick Start





The illustrations in this manual are intended as a guide and may differ from actual unit.

WELCOME

Congratulations on your purchase of this Uniden corded telephone. This unit is designed for reliability, long life and outstanding performance utilising the latest in telephone technology.

UNIDEN COMPANY PHILOSOPHY

To bring outstanding communication products to people's lives throughout the world.

FEATURES

Great features of this corded phone include

- On Hook Dialling
- Speaker phone
- Speaker phone Volume Control
- Handset Volume Control
- Ringer Volume Control
- 200 Name Phonebook with up to 3 numbers per name

Additional features

- 5 Pre-Programmed Feature Buttons*
- Record Last 10 Redial Numbers
- Clock/Alarm/Appointment Setting
- Call Timer/Call Transfer
- Stutter Dial Tone Detection
- Calculator
- Call Waiting*
- Voice Mail Message Waiting Indicator (VMWI)
- Redial/Flash and Pause
- Hearing Aid Compatible**

Short Message Service (SMS*)

- SMS Protocol 1 SMS (Short Message Service) function for max. 100 received & 100 written messages for 10 user names.
- SMS alert tone
- SMS CLIR function

Advance Alpha Display Caller ID* Features

- 50 Memory Caller ID (missed & received calls)
- Store Caller ID records to Phonebook
- VIP Caller ID records with different Alert Tones
- Call back
- Name Tagging/Name Search Functions

* Caller ID, POP ID, Voice Mail, SMS Service and the Pre-Programmed features work only if you subscribe to the service provided by your local telephone company. There is usually a fee for this service.

** The handset earpiece is designed to be compatible with hearing aids that can be inductively coupled.

CONTENTS

Installation & Safety..... (i)
 Quick Start Guide..... (ii)

Important Information
 Welcome..... 1
 Uniden Company Philosophy..... 1
 Features..... 2
 Contents..... 3
 Included in your Package..... 5
 Controls & Functions..... 6
 Function flow Chart..... 8

Installation
 Wall Mounting..... 9

How to Use Your Phone
 LCD Display..... 10
 Using Your Phone..... 10
 Speaker phone..... 10
 Redial..... 10
 Pause..... 11
 Flash..... 11
 Mute..... 11
 Hold..... 11
 Music on Hold..... 11

Using Caller ID.
 Missed Calls..... 12
 Received Calls..... 13
 Dialed Numbers..... 14

Phone Book..... 15
 Storing a name with phone numbers/setting VIP..... 16
 Searching for or editing an existing entry..... 16
 Browsing Entries..... 16
 VIP List..... 17

CONTENTS

Using the Pre-Programmed Feature Buttons

- Call Waiting..... 18
- Messages..... 18
- Call Forward..... 19
- Call Forward No Answer..... 19
- Call Forward Busy..... 20
- Call Forward Immediate..... 20
- Block Caller ID..... 21
- Caller..... 21

Calculator..... 21

Using SMS

- SMS Setting..... 22
- Setting User No..... 22
- Sending New SMS Messages..... 23
- Reviewing the Received SMS..... 24
- Modifying an SMS..... 24

Advanced Settings

- Ring Tone..... 25
- Clock..... 25
- Alarm..... 26
- Call Screen: VIP Filter..... 26
- Call Screen: Call Reject..... 27
- Stutter Dial Tone..... 27
- Call Wait ID ON/OFF (CID Type 2)..... 27
- First Ring..... 27
- Area Code..... 28
- SMS Setting..... 28
- LCD Contrast..... 28
- Reset..... 29
- Delete SMS..... 29
- Delete Phonebook..... 29
- Delete Call List..... 29
- Delete All..... 29

Troubleshooting..... 30

Warranty..... 31

INCLUDED IN YOUR PACKAGE

Included in Your Package



1 x Base Unit

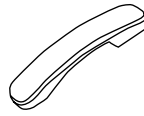

1 x Handset

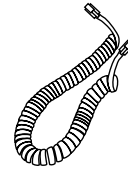

1 x Curly cord



1 x Line cord

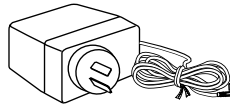

1 x AC Adaptor

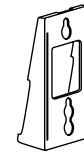

1 x Wall Mounting
Bracket & screws

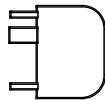

1 x Line cord Adapter

Additional Materials

- This Owner's Manual
- Other Printed Materials

CONTENTS









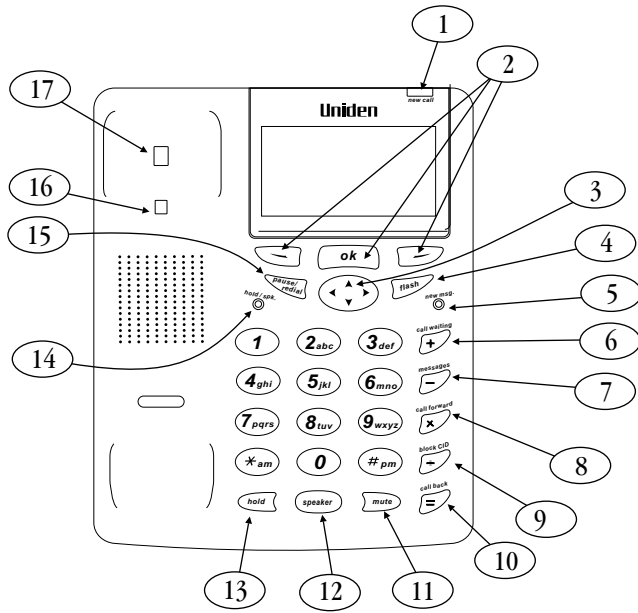



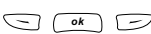

NOTE

If any of these items are missing or damaged contact your place of purchase.

CONTROLS & FUNCTIONS



CONTROLS & FUNCTIONS

- | | |
|--|--|
| 1 New Call LED | 10 Callback  |
| 2 Soft Keys  | 11 Mute  |
| 3 Scroll Keys  | 12 Speaker  |
| 4 Flash  | 13 Hold  |
| 5 New SMS LED  | 14 Hold/ Speaker LED  |
| 6 Call Waiting  | 15 Pause/Redial  |
| 7 Messages  | 16 Handset Retainer Tab |
| 8 Call Forward  | 17 On Hook Switch |
| 9 Block CID  | |

CONTROLS & FUNCTIONS

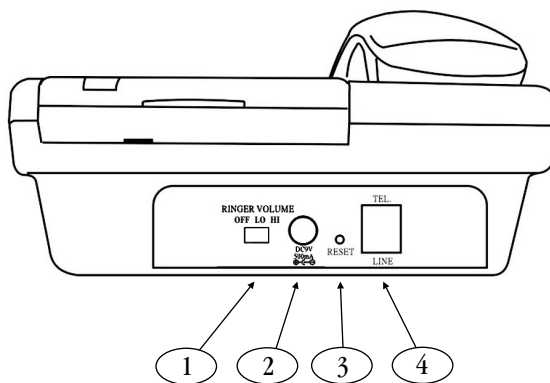

Rear Connections & Controls

1. Ringer Volume control
2. DC power socket
3. Telephone Reset
4. Telephone Line socket

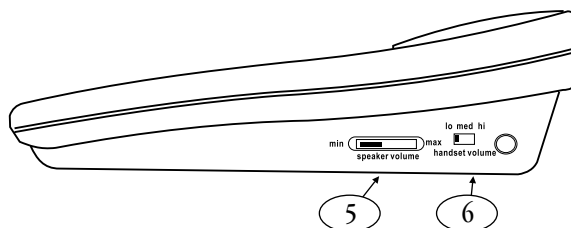

Side Controls

5. Speaker Volume control
6. Handset Volume control

FP106 FUNCTION FLOW CHART

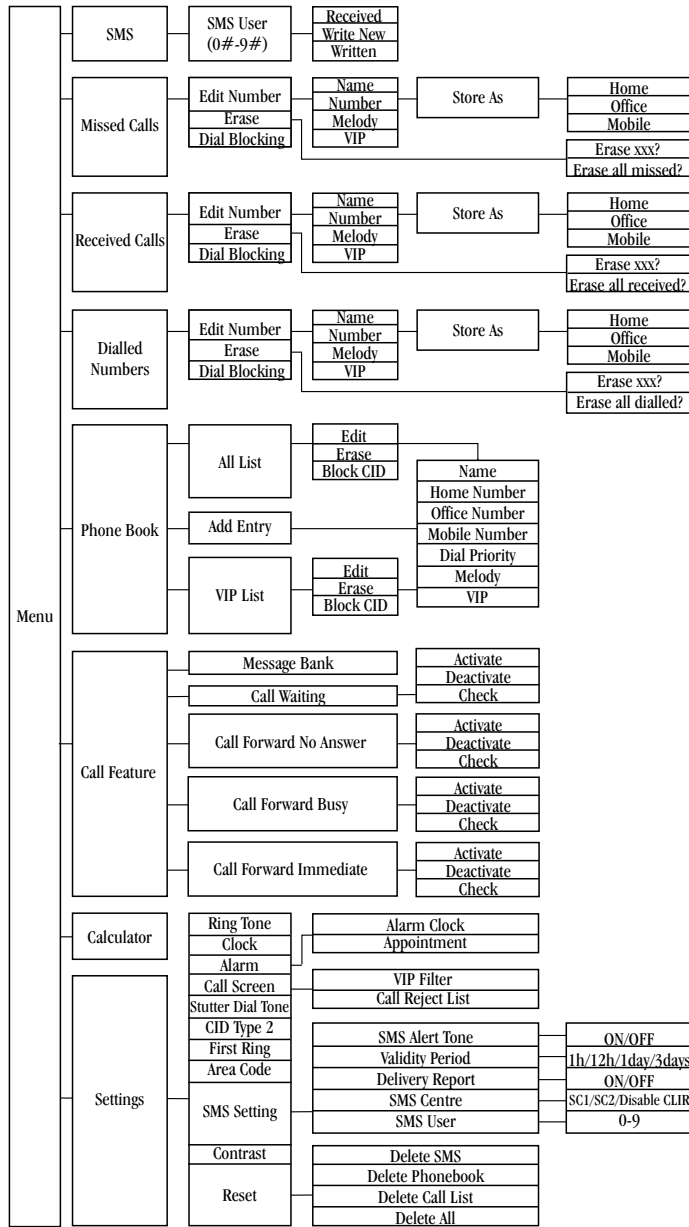

INSTALLATION

WALL MOUNTING

If required, you can mount your phone directly on a wall.

- Before mounting your phone, please consider the following:
- Select a location away from electrical cables, pipes or other items behind the mounting location that could cause a hazard when inserting screws into the wall.
- Make sure the wall material is capable of supporting the weight of the telephone.
- Use the screws (supplied) with anchoring devices suitable for the wall material where the Telephone will be placed.

1. Insert two mounting screws 100 mm apart. Allow about 5mm between the wall and screw heads for mounting the phone.

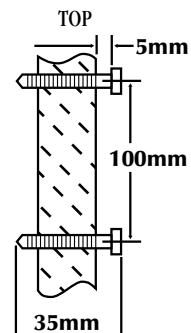

2. Gently pull out the handset retainer tab, turn 180° and re-fit. See Controls & Functions Page 5 for location of Handset Retainer Tab.

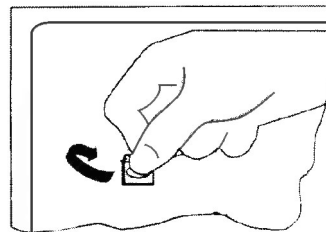

3. Attach the wall mounting bracket to the bottom of the telephone as shown.

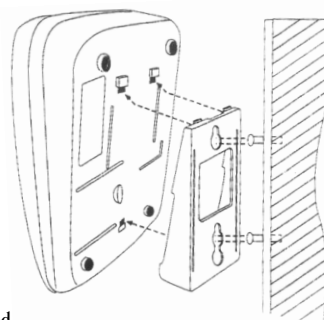







4. Place the base unit on the screws and push down until it's firmly seated.

HOW TO USE YOUR PHONE

The following page information expands on the basic phone use as explained in Step 4 of the Quick Start Guide.

LCD Display:

ICON	NAME
	: APPOINTMENT
	: MUTE
	: SPEAKER
	: MSG WAITING
	: CID
	: PHONE BOOK

The Icons shown here will display at the top of the Display window when such functions are in operation.

The icon names will appear at the bottom of the Display window.

Using Your Phone

1. To make a call:

Pick up handset or press  Listen for the dial tone, then dial phone number.

Or for On Hook Dialling:

Dial the number first, then pick up handset or press 

2. To answer a call:

Pick up the handset to talk to the other party or press  to use the speaker phone.

3. To end a call:

Place handset back into cradle of base unit or if using the speaker phone press 



SPEAKER PHONE

You can continue a call on Speaker phone mode anytime by pressing the  button during a call, then place the Handset on the base.

When speaking, Speak clearly towards the base of the telephone.

Also, you can transfer a call to the Handset anytime during a call by simply picking up the Handset.

REDIAL

If you want to redial the last number dialled, simply pick up the handset or press the  button, then press the  button. The telephone will automatically dial the last dialled number.

PAUSE



During the Phonebook storage procedure, you may wish to press the  button to insert a pause between numbers. (This is sometimes useful for accessing a switch board, telephone banking or long distance dialling).



Pressing  button more than once will increase the pause between digits.





Each time the  button is pressed, a 'P' will show on the LCD to indicate a 2 second pause in the dialling sequence. Each pause counts as one digit.

FLASH

The Flash feature can be used to momentarily break the line for transferring calls on a PABX system or for a Call Waiting service.

While talking, you hear the call waiting signal (series of beep tones), press the  button then  to switch call and put the current call on hold.

To switch back to original call, press the  button then .

1. Pressing  +  toggles the call between the incoming and the original call.
2. Pressing  +  will drop the current call connection and pick up the incoming call or the call on hold.

MUTE

Press the  button to turn off the handset microphone, allowing private conversations in the same room without the other party hearing.

Press the  button again to resume the conversation with the calling party.

HOLD

To place a call on hold, press the  button and hang up.

To begin conversation again, pick up the handset or press the  button or pick up an extension phone (if available).

MUSIC ON HOLD

When a call is placed on hold, the FP106 will play a popular melody to reassure your caller that the call has not been disconnected. The selected melody is fixed and cannot be altered or muted.

USING CALLER ID

When subscribed to Caller ID the caller's number appears on the Display window, usually after the first ring.

Missed Calls

When someone calls and the call is not answered their number is stored in the Missed Calls list. This function allows you to view a list from which somebody tried to call you with no success.

Using the Soft Key options provided in the Missed calls menu you can view the date and time of each call, and view, edit, erase or save the number. Each memory location can store a maximum of 20-digit number and 16-digit name.

► ►

▼

▼

▼

▼

Display Example:

Missed call:	01/04
JOHN SMITH	
0932125520	
0222474816	
BOB LEE	
Details Dial Back	

The 1st number indicates the highlighted call.
The 2nd number indicates the total number of current missed calls



If there is an answer machine on the same line which answers the call then the call will be treated as a Received Call

To review missed calls

1. Select **menu** scroll to **Missed Calls** and press
2. If the same number called several times, it shows the number of times next to the telephone number.
3. Any number that has been set as a VIP call will display the VIP icon.
4. If no missed calls, the screen displays "No Missed Calls".

Received Calls

This function allows you to view a list from which you have recently accepted calls.

Using the Soft Key options provided in the Received calls menu you can view the date and time of each call, and view, edit, erase or save the number. Each memory location can store a maximum of 20-digit number and 16-digit name.

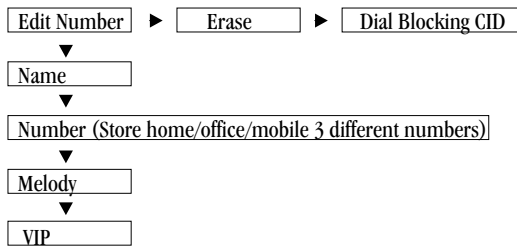

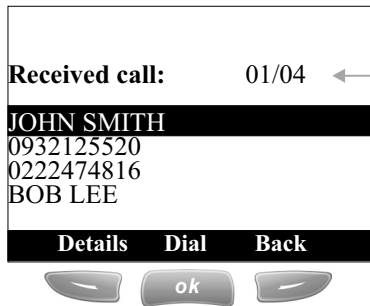

Display Example:



The 1st number indicates the highlighted Received call.

The 2nd number indicates the total received calls.

To Review Received Calls:

1. Select **Menu**  then scroll to **Received Call** and press **ok** .
2. If the same number is received twice then only the details of the latest call is stored and displayed.
3. Any number that has been set as a VIP call will display the VIP icon.
4. If no received calls, the screen displays "No Received Calls".

Dialled Numbers

This function allows you to view a list of the last 10 phone numbers that you have recently called or tried to call.

Using the Soft Key options provided in the Dialled calls menu you can view the date and time of each call, and view, edit, erase or save the number. Each memory location can store a maximum of 32-digit number and 16-digit name.

► ►
 ▼

 ▼

 ▼

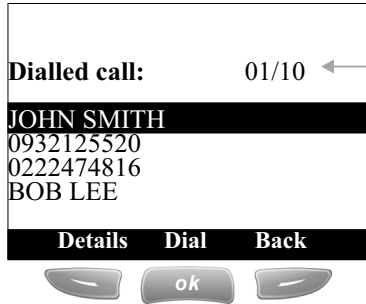

 ▼

Display example:



← The 1st number indicates the highlighted call out of the last 10 calls.

To Review Dialled Numbers:

1. Select **Menu**  then scroll to **Dialled call** and press **ok** .
2. If the same number is dialled twice, the list displays the number twice.
3. If the number is a VIP call, the VIP icon will display next to the number.
4. If no dialled numbers, the screen displays "No Dialled Numbers".

PHONE BOOK

You can store phone numbers and the associated names in the memory of the phone book. You can store up **200** names with 3 different numbers (each of which can have up to 32 digits) and other settings.

In standby mode (on or off hook) press ▲ or ▼ on the scroll key to jump to the start or end of the phonebook. Pressing ◀ on the scroll key will jump to the last dialled numbers. Pressing ▶ on the scroll key will jump to the call features

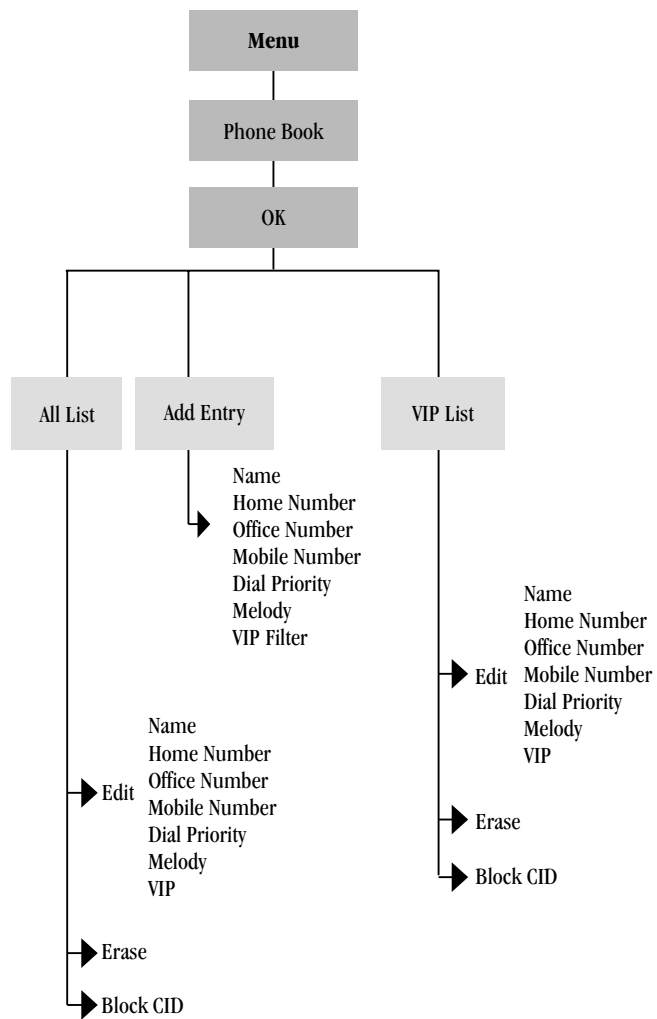

NOTE
OR press **Names** in the standby display as a shortcut.

Display example:

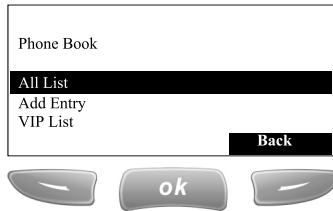

Storing a name with phone numbers/ Setting VIP

1. Select **Menu** then choose **Phone book** and press
2. Scroll to **Add Entry** and press
3. Key in the Name and number (or numbers if available)

The first character in the **Name** field must be a letter (for searching or browsing). If you make a mistake, you can remove characters to the left of the cursor by pressing **Delete** as many times as necessary. Pressing and holding **Delete** clears the screen.

To switch between upper and lower character case, press . The symbol ABC or abc shown at the top of the display indicates the selected case. The phone reverts to upper case for every new entry. To insert a space press . Pressing brings up a list of special characters. Move through the list to the desired character with and and press **Use** to insert it in the name.

After entering Name, Number (Home, Work, Mobile: Press to skip a number entry) press to view **Dial Priority**, **Melody** and **VIP** options. Press or to change or select these options.

If setting VIP to ON then the Melody selection must be set to **Ring1**, **Ring2**, **Ring3** or **No Selection**.

4. Press to confirm.

Searching for or Editing an Existing Entry

1. Select **Menu** then scroll to **Phone book** and press
2. Scroll to **All List** and press
3. Key in the first letter of the name to jump to first corresponding entry.
4. Use or to reach the desired name.
5. Press to dial the preset priority number. Or press **details** to view other numbers.
6. Press **Options** to view **Edit Number** or **Erase** options.
7. Scroll to **Edit Number** to edit the name, numbers, dial priority, melody and VIP settings for the current entry.

Browsing entries

Pressing the or button from standby mode allows browsing of the phone book. Keying in the first letter of the name jumps to first corresponding entry.



VIP needs to be selected to ON before an entry will appear in the VIP list. Please see Setting VIP on page 15.





VIP LIST

The VIP list is a list of names for whose phone number(s) triggers a secondary beeping tone. The VIP list requires the Caller ID service to work. You can transfer any Caller ID record into the VIP list.

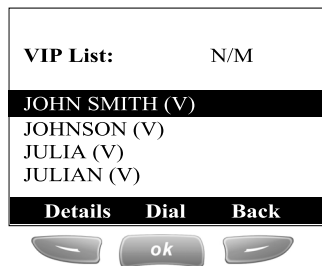
The Melody selection for each Name entry must be set to **Ring1, Ring2, Ring3** or **No Selection** for the VIP beeping tone to function. **Please see Call Screen: VIP Filter on page 26 to activate VIP function.**

Display example:





1. Select **Menu**  then choose **Phone book** and press .
2. Scroll to **VIP list** and press .
3. Use the **▲** or **▼** buttons to scroll through the VIP list.
4. When you locate the desired number, press  to dial the number or enter **Details** mode for the detail information.

USING THE PRE-PROGRAMMED FEATURES BUTTONS

Easy access to some of most popular network service features have been programmed into the telephone for your convenience.

CALL WAITING

If you subscribe to Call Waiting service, Call Waiting lets you know if you have another call while you are already on the phone. Call Waiting sends a discrete tone when you have another call.

- A discrete tone tell you someone's calling you when you're on another call. However, you have longer than this to answer the second call. The second caller simply hears a ringing tone and will usually keep holding for six to eight rings.
- Excuse yourself from the first caller, then press the  button on your phone. You can then talk to the second caller.
- To return to the first caller, simply press the  button again and you will be able to continue your original conversation.

MESSAGES

Telstra Home Messages 101 is a free, easy-to-use home message solution that allows voice messages to be left for you when you are away from the phone, on another call or dialled up to the Internet. All you have to do is dial 101 from your Telstra home phone to collect up to 10 messages at a time.

Telstra Home Messages 101 has a standard greeting and NO PIN number.

The phone will ring for approximately 20 seconds before Telstra Home Messages 101 takes the call.

To change the length of time before Telstra Home Messages 101 answers an incoming call, dial *99 and enter the number of seconds you would like the phone to ring (amount must be between 05 and 60 seconds). Then press .

When you have a message you will hear the Stutter Dial Tone when you pick up the phone receiver.

When a new message has been left in your mailbox, the  will flash on the display.



There may be a delay in these indicators turning off.

To Use Messages feature:

1. Press the  button.
2. Enter your PIN at the prompt and follow the recorded instructions.



When you have cleared the message (from any phone), the Message icon  will turn off.



You can press
▶ on scroll
keys to enter
Call Features
directly.



CALL FORWARD

Call Forward Immediate (Variable Number) With Variable Number Forward you can forward your calls to a number you select and change it at any time.

1. Select **menu**  then scroll ▼ to Call Feature.
2. Scroll to Call Fwd Immediate and press  to confirm.
3. Choose Activate and the display shows Enter the Fwd Number and enter the telephone number.
4. Press  and the telephone will automatically dial the access code *21(NUMBER)# and will enable Activate Call Forward Immediate feature.
5. Choose Deactivate, the telephone will automatically dial the access code #21# and will enable Deactivate Call Forward Immediate feature.
6. Choose Check, the telephone will automatically dial the access code *#21# and will enable Check activation state feature.



CALL FORWARD NO ANSWER

Telstra's "Call Forward No Answer" service is available for diverting calls to another number if your phone is not answered within 20 seconds (approximately 7 or 8 rings).

1. Press Menu  then choose Call Feature.
2. Scroll to Call Fwd No Answer and press  to confirm.
3. Select Activate and the display shows Enter the Fwd Number and enter the telephone number.
4. Press  and the phone will automatically dial the access code "*61(NUMBER)#" and enable Call Forward No Answer feature.
5. Select Deactivate, the telephone will automatically dial the access code "#61#" and will enable Deactivate Call Forward No Answer feature.
6. Select Check, the telephone will automatically dial the access code "*#61#" and will enable Check activation state feature.



CALL FORWARD BUSY

When you know your phone is going to be busy, this feature allows you to redirect your calls to any other number anywhere in Australia.

1. Press Menu  then choose **Call Feature**.
2. Scroll to **Call Fwd Busy** and press  to confirm.
3. Select **Activate** and the display shows **Enter the Fwd Number** and enter the telephone number.
4. Press  and the phone will automatically dial the access code “*24(NUMBER)#” and enable **Call Forward Busy** feature.
5. Select **Deactivate**, the telephone will automatically dial the access code “#24#” and will enable **Deactivate Call Forward Busy** feature.
6. Select **Check**, the telephone will automatically dial the access code “*#24#” and will enable **Check activation state** feature.

CALL FORWARD IMMEDIATE

You can redirect calls to anywhere, including mobiles, pagers and answering services. Call Forward Immediate (Variable Number) With Variable Number Forward you can forward your calls to a number you select and change it at any time.

1. Press Menu  then choose **Call Feature**.
2. Scroll to **Call Fwd Immediate** and press  to confirm.
3. Select **Activate** and the display shows **Enter the Fwd Number** and enter the telephone number.
4. Press  and the telephone will automatically dial the access code “*21(NUMBER)#” and will enable **Activate Call Forward Immediate** feature.
5. Select **Deactivate**, the telephone will automatically dial the access code “#21#” and will enable **Deactivate Call Forward Immediate** feature.
6. Select **Check**, the telephone will automatically dial the access code “*#21#” and will enable **Check activation state** feature.





You can press  on scroll keys to enter Call Features directly.



You must subscribe to a Call Back service.

BLOCK CALLER ID

Each time you make a call, your telephone number is automatically forwarded to the party you are calling (unless your number is a private number). In certain cases you may wish to prevent your number being sent, follow these steps.







1. Pick up the handset or press the  button. Wait for the dial tone.
2. Press the  button.
3. Dial the telephone number of the person you wish to call. Your telephone number will be withheld for this call only.

CALL BACK

If the number you are calling is engaged, Call Back can ring you when the number is free. It will keep trying a busy number for up to 45 minutes, and (provided you have a compatible phone) will alert you with a distinctive ring when the called number is free.

1. When you dial a number and receive the engaged tone, press .
2. You will hear the confirmation announcement.
3. Hang up the phone.
4. Your phone will ring with a distinctive ring tone when the number you called is free.
5. Pickup the handset and wait for the call to be connected.

Calculator

1. Select **Menu**  then choose **Calculator** and press .
2. Using numeric keypads and      on the right side for fundamental operations of arithmetic.

The display showing “E” means the content is too long or has an error.





The  key is for a decimal point.

3. Select  button to leave.

USING SMS SERVICE

A subscription to an SMS service is required. Then you can send and receive SMS.

SMS SETTING



1. Select **menu**  then scroll **▼** to Settings and press **ok** .
2. Scroll **▼** to SMS Setting.
3. Select **ok**  to set SMS alert tone (On/Off). Once you turn on the alert tone, the Box will sound an alert every time when it receives an SMS.
4. Select **ok**  to set Validity Period. There are four options (one hour, 12 hours, one day, and 3 days). You can choose how long you would like the messages to be kept in the service centre for you to retrieve.
5. Select **ok**  to set SMS Delivery report (On/Off) if you want a report on the sending results (sent, failed, pending).
Otherwise no SMS functions will operate.

SETTING USER NO.



This FP106 can be used by multiple users or connected in parallel to other SMS capable product.

If you do not want to set up any user names or passwords and have only one SMS entity, you can simply use the phone and neglect the user no.

When you have more than one SMS product in your house, or want to set up user names and passwords to protect your privacy, please read the following instructions carefully.













1. Select **menu**  then scroll **▼** to Settings then press **ok** .
2. Scroll **▼** to SMS Setting.
3. Press **ok**  to confirm.
4. Scroll **▲** or **▼** to select SME User (0# - 9#).
5. Choose the desired user number (0-9) and it is the terminal number.



Once you decide to set the user No., always set user NO. 0 because many SMS will be sent to user NO. 0. Apart from user NO. 0, you can choose whatever user No. (between 1-9) you want.

6. Press **ok**  to confirm.
7. Enter your user name (up to 10 digits) and password.
8. Press **ok**  to confirm.

Press Back to return to the standby mode or press **▲** or **▼** to set other functions.

SENDING NEW SMS MESSAGES

1. In standby mode, press SMS OR select **menu**  then scroll  to SMS then press  Scroll  to User and press  There are 3 features SMS Received, SMS Write new?, SMS Written?
2. Scroll  or  to SMS Write new appears. Press  to confirm.
3. Use keypad to key in the message content.
Each SMS message may contain a maximum 160 characters. Press  or  to move cursor in the text field. The next digit entered will appear to the right of the cursor. Press Delete to delete the digits at the left of the cursor. Hold down Delete to delete all digits at the left of the cursor.
4. When finished, press OK and enter the information for No. and Terminal.
5. Press  to confirm all information in the message and select Send and save.
6. Press  again to send the message. The display shows Sending.
7. If sending fails, the display will show Send error then show Send and Save. If you press  the message will be resent again. If you press Back, the FP106 will return and by mode. If the message is transmitted, the display shows Send OK and return to written mode.

- 1) You must enter the receiver's telephone number when sending an SMS. Other information can be omitted.
- 2) You can select Load from phonebook to recall the phone book records.
- 3) Press  to switch ABC/abc
- 4) Press  to choose specific characters.
- 5) When you are writing an SMS message and the ring is coming, the message will store on the "Written" box. You can retrieve the unfinished message from the "Written" box.

REVIEWING THE RECEIVED SMS

1. In standby mode, press SMS.
2. Choose a User and press
3. Press Received and choose a SM then press
4. Press ▲ or ▼ to see the SMS content.
5. Press to reply/Dial/Forward/Delete the message.

MODIFYING AN SMS





To modify the message content of a finished or received SMS, follow the standard steps below.

1. Select **menu** and scroll to SMS and press OK. Select User and press OK.
2. Choose the message you wish to modify. For example, choose SMS written? and press to confirm.
3. Select **OK** and scroll to Modify?.
4. Press to modify the message. When you have finish the modification, press and you will be prompted with save? or send?
5. Press for Save?
6. You can choose Load from phonebook to recall the phone book records before sending out the SM. Press for the desired name.
7. When you finish the modification, press to confirm all information in the message and press when the display shows Send?

ADVANCED SETTINGS

RING TONE

There are 4 different ring tones, 12 melody music for your options.







1. Select **Menu**  then scroll to **Settings** and press **ok** .
2. Scroll to **Ring Tone** and press **ok**  to confirm.
3. Scroll to desired tone.
4. Press **ok**  to confirm.

NOTE

Selecting a Melody tone as the main ring tone will not affect the VIP function.

CLOCK

If you do not subscribe to a Caller Display service you will need to set the clock as follows.





1. Select **Menu**  then scroll to **Settings** and press **ok** .
2. Scroll to **Clock** and press **ok**  to confirm.
3. Use the keypad buttons to set the date and time manually following the cursor position.
4. Press ***am**  or **#pm** .
5. Press **ok**  to confirm.

NOTE

If you make a mistake use the **◀** or **▶** buttons to move the cursor and re-enter the correct information.

Clock Display Form

You can choose between an analogue and a digital display as follows.

1. Select **Menu**  then scroll to **Settings** and press **ok** .
2. Scroll to **Clock** and press **ok**  to confirm.
3. Press **▼** and then **▶** key to choose Digital or Analog.
4. Press **ok**  to confirm.



The Phone alarms at a specified time everyday unless you turn the alarm clock off.









An error tone sounds when an invalid time is entered.

ALARM

The phone can be set to alarm at a specified time. Please see the Clock and Appointment instructions below for actual settings.







ALARM CLOCK

When the alarm time is reached, the phone sounds an alert tone. When the phone is alerting, "Alarm Clock" is shown on the LCD display. Press any key to stop the alarm.

1. Select **Menu**  then scroll to **Settings** and press 
2. Scroll to **Alarm** then select Alarm clock and press 
3. Use the keypad buttons to set the alarm time.
4. Scroll  to **On/Off**, then scroll  or  to turn **ON or OFF**.
5. Press  to confirm.

ALARM APPOINTMENT

The function helps you to keep track of reminders, calls that you need to make, meetings, and birthdays. The phone sounds an alarm tone when the alarm time is reached. Press any Key to stop the alarm.





1. Select **Menu**  then scroll to **Settings** and press 
2. Scroll to select **Alarm Appointment** and press 
3. Use the keypad buttons to set the alarm time.
4. Scroll  to **Note** to write a note. Please see **Storing a Name with Phone numbers** on page 16 for instructions on how to enter text.
5. Scroll  to **On/Off**, then scroll  or  to turn **ON or OFF**.

CALL SCREEN

You can set VIP Filter and Call Reject List. Call Screen allows you to set a filter for your VIP calls.

VIP FILTER

In the case that the VIP filter is set **ON**, all calls will ring normally but numbers in the VIP list will ring with a second beeping tone as well. In the case that the VIP Filter is **OFF** all calls ring normally with no secondary beeping tone.

1. Press **Menu**  then scroll to **Settings** and press 
2. Scroll to **Call Screen** then press **VIP Filter**.
3. Press  or  to turn VIP Filter **ON Or OFF**.
4. Press  to confirm.



You will hear the Call Wait confirmation while on a call to let you know of another caller.





CALL REJECT LIST

The Call Reject List is able to store 5 numbers. The function of the Call reject list is to screen incoming calls for any of those numbers and to answer and then hang up the call after 3 rings. Numbers in the Call Screen List ring with a secondary ring tone on top of the normal ring. This ring is sounded briefly after entries are confirmed in the list to alert the user. The Call Reject List is always on.

1. Press **Menu**  then choose **Settings**.
2. Scroll to **Call Screen** then choose **Call Reject List**.
3. Press **Edit** to edit the numbers; you can press **▲** or **▼** to edit other numbers.





STUTTER DIAL TONE

The Stutter Dial Tone Detect enables the phone to listen to the phone line for the stutter dial tone used to indicate a message waiting on a voice mail service.

1. Select **Menu**  then scroll to **Settings** and press .
2. Scroll to **"Stutter dial tone"** then press .
3. Press **◀** or **▶** to turn Stutter Dial Tone **ON** Or **OFF**.
4. Press  to confirm.



CALL WAIT ID ON/OFF (CID Type 2)

This feature allows you to see the number of the calling party (unless the call is blocked or is from a private number) while you are on call. You can choose turn on or turn off the function.



1. Select **Menu**  then scroll **▼** to Settings and press .
2. Scroll **▼** to CID Type 2 then press .
3. Scroll **▲** or **▼** to select CID type 2 ON/OFF
4. Press  to confirm.

FIRST RING





You can cancel first ring to prevent the incoming SMS being interrupted by off-hook.

1. Press **Menu**  then choose **Settings**.
2. Scroll to **First Ring** then press .
3. Move the buttons **◀** or **▶** to choose First Ring **ON/OFF**
4. Press  to confirm.

AREA CODE





1. Press **Menu**  then choose **Settings**.
2. Scroll to **Area Code** then press .
3. Key in the local area code.
4. Press  to confirm.

SMS SETTING

1. Press **Menu**  then scroll to **Settings** then press
2. Scroll to **SMS Setting**.
3. Press  to set **SMS alert tone (On/Off)**. Once you turn on the alert tone, the FP106 will sound an alert every time an SMS message is received.
4. Press  to set **Validity Period**. There are four options (one hour, 12 hours, one day, and 3 days). You can choose how long you would like the messages to be kept in the service centre for you to retrieve.
5. Press  to set **SMS Delivery report (On/Off)** if you want a report on the sending results (sent, failed, pending).

LCD CONTRAST

You can choose the desired luminance of the Display Window by following the steps below.









1. Select **Menu**  then scroll to **Settings** and press
2. Scroll to **Contrast** then press .
3. Scroll  or  to choose the desired level.
4. Press  to confirm.

RESET

You can delete the Phonebook entries (including old and new entries), Caller Display lists (including old and new entries) or delete all using the instructions below.





DELETE SMS

To delete all messages from the SMS history:

1. Select **Menu**  then scroll  to **Settings** and press 
2. Scroll  to **Reset** and press 
3. Scroll  to **Delete SMS** and press
4. Scroll  or  to select **Yes** or **No**.
5. Press  to confirm.





DELETE PHONE BOOK

All records of phone book will be deleted.

1. Select **Menu**  then scroll to **Settings** and press 
2. Scroll to **Reset** then press **Delete Phonebook**.
3. Scroll  or  to select **Yes** or **No**.
4. Press  to confirm.





DELETE Call List

All missed calls, received calls and dialled number call list will be deleted.

1. Select **Menu**  then scroll to **Settings** and press 
2. Scroll to **Reset** then press **Delete Call List**.
3. Scroll  or  to select **Yes** or **No**.
4. Press  to confirm.

DELETE All

Deletes all stored memories and resets all pre-programmed codes to factory default.

1. Select **Menu**  then scroll to **Settings** and press 
2. Scroll to **Reset** then press **Delete All**.
3. Scroll  or  to select **Yes** or **No**.
4. Press  to confirm.

TROUBLESHOOTING

If your telephone is not performing to your expectations, here are some suggestions on how to resolve the problem.

Problem	Suggestion
Can't make or receive calls. No Dial Tone.	<ul style="list-style-type: none"> • Make sure you use only the line cord supplied with this telephone. • Check that both ends of the telephone line cord and Handset cord are plugged in. • Plug another telephone into the telephone socket and check for a dial tone.
Can't hear the telephone ringing.	<ul style="list-style-type: none"> • Make sure the AC adaptor is plugged in and the wall socket switched on. • Make sure you do not have too many telephones connected to the telephone line. • Adjust the Ringer Volume Control.
Speaker phone volume is too low.	<ul style="list-style-type: none"> • During speaker phone conversation, adjust the speaker volume slider control on the side of the telephone.
Handset does not hang up in the wall mount position.	<ul style="list-style-type: none"> • Make sure the Handset Retainer Tab has been turned around (point facing up) and the Handset is placed firmly into the cradle.
New Call LED keeps flashing.	<ul style="list-style-type: none"> • All new calls must be reviewed before the new call LED stops flashing.
Caller Display and/or SMS Messaging feature not working Pre-programmed features not working.	<ul style="list-style-type: none"> • These are all subscription services. To subscribe, or check the pricing and availability, please contact your line services provider.
Blank or faint LCD screen.	<ul style="list-style-type: none"> • Make sure the AC adaptor is plugged in and the wall socket switched on. • Check / adjust the contrast control setting as described on page 28.
Speaker phone or display not working.	<ul style="list-style-type: none"> • Make sure the AC adaptor is plugged in and the wall socket switched on.

WARRANTY

WARRANTY

One Year Limited Warranty

Important: Evidence of original purchase is required for warranty service.

Warrantor: Uniden Australia Pty Limited. ABN 58001 865 498

Uniden New Zealand

ELEMENT OF WARRANTY: Uniden warrants to the original retail owner for the duration of this warranty, its FP106 (herein after referred to as the Product), to be free from defects in materials and craftsmanship with only the limitations or exclusions set out below.

WARRANTY DURATION: This warranty to the original retail owner only, shall terminate and be of not further effect 12 months after the date of original retail sale. This warranty will be deemed invalid if the product is; (A) Damaged or not maintained as reasonable and necessary, (B) Modified, altered or used as part of any conversion kits, subassemblies, or any configurations not sold by Uniden, (C) Improperly installed, (D) Repaired by someone other than an authorised Uniden Repair Agent for a defect or malfunction covered by this warranty, (E) Used in conjunction with any equipment or parts or as part of a system not manufactured by Uniden. (F) Only available in the original country of sale.

PARTS COVERED: This warranty covers for one (1) year, the FP106 Unit and Handset only. All accessories (Cables etc.) are covered for 90 days only.

STATEMENT OF REMEDY: In the event that the Product does not conform to this warranty at any time while this warranty is in effect, the warrantor at its discretion, will repair the defect or replace the product and return it to you without charge for parts or service. **THIS WARRANTY DOES NOT COVER OR PROVIDE FOR THE REIMBURSEMENT OR PAYMENT OF INCIDENTAL OR CONSEQUENTIAL DAMAGES. THIS GUARANTEE IS IN ADDITION TO AND DOES NOT IN ANY WAY AFFECT YOUR RIGHTS UNDER THE CONSUMER GUARANTEE ACT.**

PROCEDURE FOR OBTAINING PERFORMANCE OR WARRANTY: In the event that the product does not conform to this warranty, the Product should be shipped or delivered, freight pre-paid, with evidence of original purchase (e.g. a copy of the sales docket), to the warrantor at:

UNIDEN AUSTRALIA
SERVICE DIVISION
345 Princes Highway,
Rockdale NSW 2216
Fax (02) 9599 3278

www.uniden.com.au

UNIDEN NEW ZEALAND LIMITED
SERVICE DIVISION
150 Harris Road,
East Tamaki, Auckland
Fax (09) 274 4253

www.uniden.co.nz

Customers in other States should ship or deliver the Product freight pre-paid to their nearest Uniden Authorised Repair Centre (Contact Uniden for the nearest Warranty Agent to you).

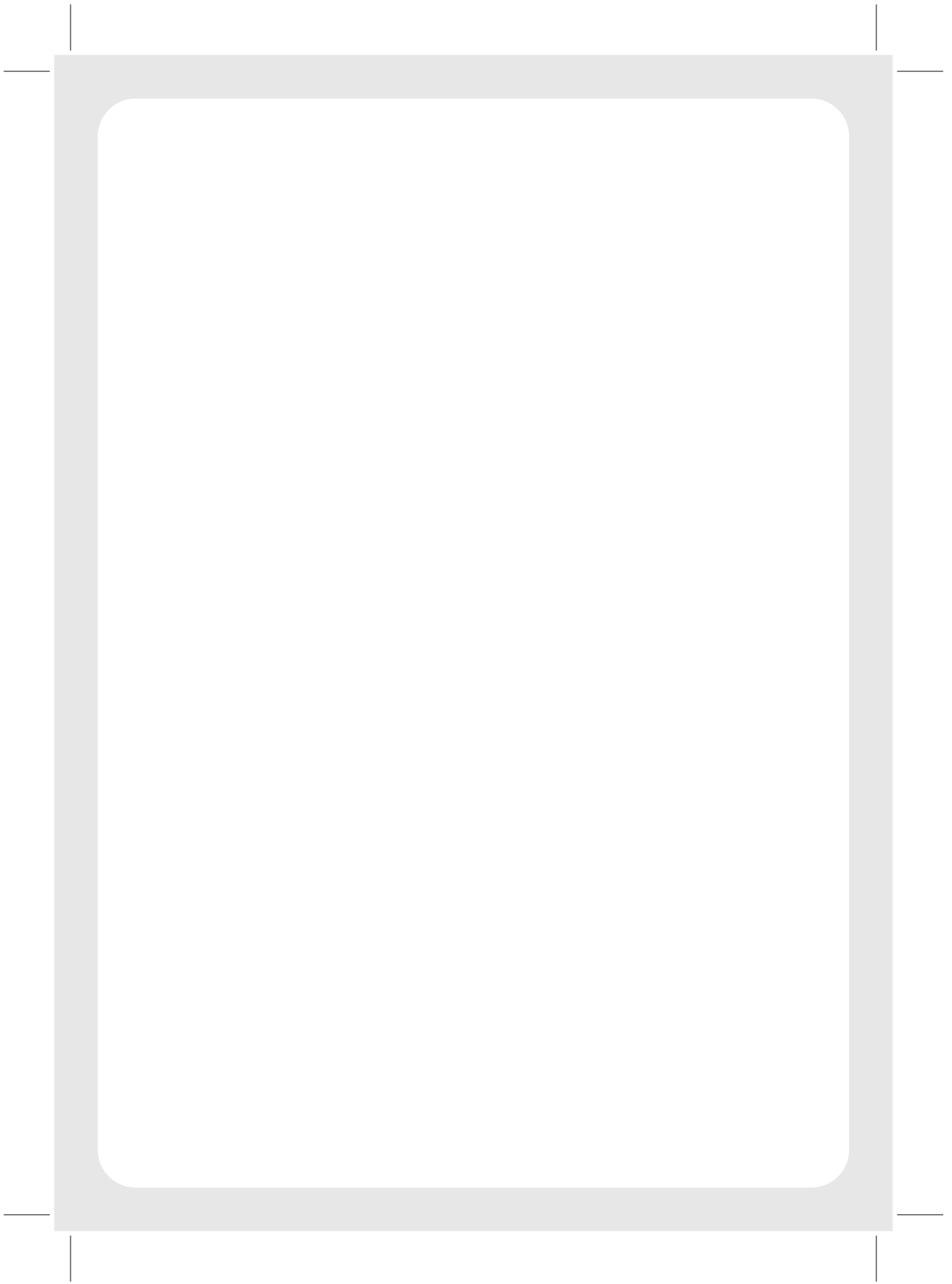

THANK YOU

FOR PURCHASING A UNIDEN PHONE

Uniden

© 2004
Uniden Australia Pty Limited
Uniden New Zealand Limited