



INSTALLATION AND OPERATING INSTRUCTIONS

FULL SIZE ELECTRIC CONVECTION OVENS

Models: COB-E and COM-E

INTENDED FOR OTHER THAN HOUSEHOLD USE
RETAIN THIS MANUAL FOR FUTURE REFERENCE
OVEN MUST BE KEPT CLEAR OF COMBUSTIBLES AT ALL TIMES



FOR YOUR SAFETY: Do not store or use gasoline or other flammable vapors and liquids in the vicinity of this or any other appliance.



WARNING: Improper installation, adjustment, alteration, service or maintenance can cause property damage, injury or death. Read the Installation, Operating and Maintenance Instructions thoroughly before installing or servicing this equipment.



WARNING: Initial heating of oven may generate smoke or fumes and must be done in a well-ventilated area. Overexposure to smoke or fumes may cause nausea or dizziness.



This equipment has been engineered to provide you with year round dependable service when used according to the instructions in this manual and standard commercial kitchen practices.



Form # 8898450 7/07

Phone: (864) 963-3471
Fax: (864) 963-5316
Toll Free: (800) 927-6887
Website: www.bkideas.com
E-mail: customerservice@bkideas.com

BKI Worldwide Headquarters
PO Box 80400
Simpsonville, SC 29680-0400 USA

INDEX

I. INSTALLATION INSTRUCTIONS			SECTION	ITEM	PAGE
SECTION	ITEM	PAGE			
A	Receiving.....	2		3. Cook & Hold.....	6
B	Set-up/Mounting.....	2		4. Steam Injection (Optional).....	6
C	Installation with Casters.....	3		5. Oven Cool Down.....	6
D	Location & Minimum Clearances.....	3	D	C Cleaning.....	7
E	Electrical Connections.....	4		D Servicing.....	8
F	Flue Connection Ventilation.....	4		1. Stacking Instructions.....	9
G	Initial Cleaning.....	4	E	2. Leg Assembly Instructions.....	10
H	System Check - Rotary Controls.....	5		E Wiring Diagrams.....	11
				1. Single Phase 208V or 240V Wiring Diagram (Dial Control).....	11
				2. Three Phase 208V or 240V Wiring Diagram (Dial Control).....	12
				3. Single Phase 208V or 240V Wiring Diagram (CH-100 Control).....	13
				4. Three Phase 208V or 240V Wiring Diagram (CH-100 Control).....	13
			F	Parts List w/Exploded View.....	14
				Warranty.....	16
II. OPERATING INSTRUCTIONS					
SECTION	ITEM	PAGE			
A	General Instructions.....	5			
B	Operation Sequence For Rotary Controls....	5			
	1. Cook Only.....	5			
	2. Timed Cooking.....	6			

I. INSTALLATION INSTRUCTIONS

A. RECEIVING

Read the notice on the outside carton regarding damage in transit. Damage discovered after opening the carton is "CONCEALED DAMAGE." Carrier must be notified immediately to send an inspector and to furnish forms for claims against the carrier.

When the oven arrives, it should consist of:

- A crate or carton containing your new oven (two for a stacked unit).
- A carton containing four 31" legs with mounting hardware (set of four 6" legs is supplied for stacked installations).
- A carton containing a Flue Adapter and a Draft Hood. Optional: for Direct Venting (Not available for European Community Countries).

B. SET UP / MOUNTING:

NOTE:

This appliance must be installed by competent personnel in accordance with the rules in force.

Your oven will be packed sitting on its bottom. The skid may be left under the oven for convenience in further handling. Unpack carefully, avoiding damage to the Stainless Steel front and/or trim. If concealed damage is found, follow the instructions detailed in Section A (Receiving). Keep the area around the ovens free and clear of combustible materials. Do not store any materials on top of or under any oven. The provision of adequate air supply to your oven for ventilation is essential. As a minimum, observe the clearances detailed in Section D (Location). Provide adequate ventilation and make up air in accordance with local codes. Servicing your oven is done through the front control panel and right side access cover. Ensure that these areas are kept unobstructed for easy access.

For a single unit: Refer to Figure 4

- (1) Tilt Oven over to left-hand side and attach two 31" legs on the right-hand side with four 3/8-16" bolts and washers. Tighten firmly.

- (2) Using proper lifting equipment, lift up the left-hand side and attach two 31" legs on the left-hand side the same way.

For a stack of two ovens: Refer to Figure 3

- (1) Remove flue from top oven and replace with flue-adaptor supplied in the stacking kit.
- (2) Tilt lower unit over to the left side and position two 6" legs on the right side (one for front and one for back), secure in place by using 4 bolts (3/8-16) per leg. Tighten firmly.
- (3) Using proper lifting equipment, lift up the left side of the unit and attach the other two legs in the same way.
- (4) Using the lifting equipment, raise the top oven to proper height and slide onto top of the bottom oven. Line up sides and front and fasten to each other at the rear of the units by using a mounting bracket supplied in the stacking kit.

To assemble an open rack stand: Refer to Figure 2

- (1) Loosen 12 bolts (attaching 31" legs) slightly.
- (2) Remove 4 inner bolts, 1 from each of the 4 legs, place top right angle and top left angle underneath and tighten these 4 bolts.
- (3) Insert "Open Rack Shelf" and tighten into place with eight 3/8-16 screws, washers and nuts.
- (4) Position "Rack Supports" and tighten in place using 4 each of flat washers and 5/16-18 Hex Nuts.

C. INSTALLATION WITH CASTERS (OPTIONAL):



Four casters (two with wheel brakes) and the mounting hardware are packed and included in the shipment if ordered. Install casters with wheel brakes on the front of the unit. Installation must conform to **UL 197: Electrical Supply Connections For Permanently Connected Appliances**. It requires that permanently connected appliances with casters be provided with a means for securing the appliance to the building structure to limit the movement of the appliance.

Oven Restraint: When casters are installed on either a single or double unit, a fixed restraint must be used to limit the movement of the appliance without depending on or transmitting stress to the electrical conduit. The restraint (a heavy-gauge cable) should be attached to the rear legs of the oven on which casters are mounted. If disconnection of the restraint is necessary, the restraint must be reconnected after the oven has been repositioned in its permanent location. The appliance shall be installed using flexible conduit.



D. LOCATION AND MINIMUM CLEARANCES:

Move the oven to its final location keeping the minimum clearance from the back of the oven to the wall. This clearance is necessary for safe operation and to provide proper air flow.

MINIMUM CLEARANCES FROM COMBUSTIBLE AND NONCOMBUSTIBLE CONSTRUCTION	
	Under Ventilation Hood
RIGHT WALL	1"
LEFT WALL	1"
REAR WALL	3"

 Suitable for installation on combustible floor when installed with legs or casters provided. 

 **CAUTION:** Do not set the oven with its back flat against the wall. It will not operate properly unless there is at least three inches breathing space behind the oven 

 **NOTICE:** Local codes regarding installation vary greatly from one area to another. The National Fire Protection Association, Inc., states in it's NFPA 96 latest edition that local codes are "authority having jurisdiction" when it comes to requirements for installation of equipment. Therefore, installations should comply with all local codes. 

E. ELECTRICAL CONNECTION:

Install according to the spacing requirements listed in the installation section of this manual. We strongly recommend having a competent professional install this equipment. A licensed electrician should make the electrical connections and connect power to the unit. Local codes should always be used when connecting these units to electrical power. In the absence of local codes, use the latest version of the National Electrical Code.

Note: For supply connections use No. 6 AWG wires suitable for at least 90°C.

The oven, when installed, must be electrically grounded in accordance with local codes and/or the latest edition of the National Electrical Code ANSI/NFPA No. 70 in the USA (Canadian Electrical Code CSA Standard C22.1, Part 1 in Canada).

In Europe, the appliance must be connected by an earthen cable to all other units in the complete installation and, thence, to an independent earth connection in compliance with EN 60335-1 and/or local codes.

Electrical power is to be supplied to the oven(s) by means of hard wiring, which is to be performed by a qualified licensed electrician.

- a) Adequate means must be provided to limit the movement of the appliance without depending on or transmitting stress to the electrical conduit.
- b) The location(s) where restraining means are to be attached to the appliance shall be specified.
- c) The appliance shall be installed using flexible conduit.

COB-E, COM-E											
Model	KW	Voltage	Phase	Amps				Motor-50hz		Motor-60hz	
				Line 1	Line 2	Line 3	N	RPM (Low)	RPM (High)	RPM (Low)	RPM (High)
COB-E, COM-E	10.5	208	1	48	48	-	-	725	1425	850	1725
	10.5	208	3	30	30	28	-	725	1425	850	1725
	10.5	220-240	1	44	44	-	-	725	1425	850	1725
	10.5	220-240	3	26	26	24	-	725	1425	850	1725

Each oven requires separate electrical connections!

Normal factory connections are made for 208 V. A.C. or 208/240 V.A.C., 60 hz.

This unit is provided with a permanently lubricated electric motor. A wiring diagram may be found on the back of the service panel on the right-hand side and also in this manual.

F. FLUE CONNECTION VENTILATION:

Installation under ventilation hood (standard):

Local inspectors and ventilation specialists should be consulted so that the design and the installation of the hood conform to local/municipal codes. In the U.K., follow ventilation requirements as detailed in B.S. 5440.

NOTE: DO NOT PUT A DAMPER IN THE FLUE AND DO NOT CONNECT A BLOWER DIRECTLY TO THE FLUE.

If the flue runs directly to the free air outside the building, use a wind deflector or a UL listed vent cap at the end of the pipe. Termination of the vent must be at least two feet above the highest part of the roof within ten feet. REF: AGA CATALOG NO. Xh0474.

G. INITIAL CLEANING :

Always clean equipment thoroughly before first use. Clean the protective oil from the metal parts and interior of baking chamber with a solution of washing soda or the other grease dissolving material.

H. SYSTEM CHECK-ROTARY CONTROL (standard):

- (1) Open the oven door.
- (2) Turn Selector Switch to "HI." The green indicator light near Selector Switch and oven light will illuminate.
- (3) Close the door. Oven lights will go off and fan will run. Make sure fan is rotating clockwise looking from front.
- (4) Press Oven Light switch. Oven light will go on and will go off as switch is released.
- (5) Turn the thermostat knob. The amber indicator light near the thermostat will illuminate and the heating elements will come on.
- (6) Turn the timer knob past 10 minutes and back to 2 minutes. At the end of 2 minutes the buzzer will sound. Reset by turning to "0." All settings below 10 minutes require turning past 10 minutes and then back to the time required.
- (7) Open the oven doors. Oven lights will go on and elements and fan will go off.
- (8) Turn Selector Switch to "Cool Down" position. The fan will run to cool down the oven.
- (9) Turn Selector Switch to "0" position.
- (10) Close the oven doors.

NOTE: WITH THE DOORS CLOSED, THE POWER SWITCH "ON" AND THE SELECTOR SWITCH IS IN ANY POSITION OTHER THAN "0", THE OVEN WILL START HEATING AS SOON AS THE SET TEMPERATURE IS HIGHER THAN THE OVEN TEMPERATURE.

THERMOSTAT INDICATOR LIGHT GOES OUT WHEN OVEN REACHES SET TEMPERATURE AND COMES ON WHEN OVEN IS HEATING UP.

IN THE EVENT OF POWER FAILURE, THE OVEN WILL NOT OPERATE.



PROGRAMMING MENUS: See Operating/Programming Instruction Booklet for Programmable Oven Control with this option.



II. OPERATING INSTRUCTIONS

A. GENERAL INSTRUCTIONS:

- (1) This equipment has an Electronic Temperature Control.
- (2) Due to increased efficiency of this oven, the temperature of standard recipes may be reduced 50°F (30°C).
- (3) Always load each shelf evenly. Space pans away from each other and from sides and back of oven to allow maximum air flow between them.
- (4) Large tempered glass windows and interior lights allow a close check on the product making it unnecessary to frequently open the doors. Products cook faster in a convection oven as compared to a conventional oven. Depending on the product and the type of pans used, time saving may run from 20 percent to as high as 50 percent.

B. OPERATION SEQUENCE ROTARY CONTROL:

Cook only rotary control:

- (1) Close the oven doors.
- (2) Turn Selector Switch to "HI" or "LO" position. The indicator light near the Selector Switch will be illuminated.
- (3) Turn the thermostat knob to the desired cooking temperature.
- (4) Upon reaching the set temperature, the indicator light near the thermostat will go out.
- (5) Load the oven with product to be cooked.
- (6) Remove the product from the oven when done.

Timed cooking rotary control:

- (1) Close the oven doors.
- (2) Turn Selector Switch to "HI" or "LO" position. The indicator light near the Selector Switch will be illuminated.
- (3) Turn the thermostat knob to the desired cooking temperature.
- (4) Upon reaching the set temperature, the indicator light near the thermostat will go out.
- (5) Load the oven with product to be cooked.
- (6) Turn the timer knob to the desired bake time and timer will start counting down.
- (7) When timer reaches zero, a buzzer will sound.
- (8) Turn the timer knob to "O" position.
- (9) Remove the product from the oven.

NOTE: TIMER DOES NOT CONTROL THE OVEN.

Cook and Hold Rotary Control:

- (1) Close the oven doors.
- (2) Turn Selector Switch to "HI" or "LO" position. The indicator light near the Selector Switch will be illuminated.
- (3) Turn the thermostat knob to the desired cooking temperature.
- (4) Upon reaching the set temperature, the indicator light near the thermostat will go out.
- (5) Load the oven with product to be cooked.
- (6) Turn the timer knob to the desired bake time and timer will start counting down.
- (7) When timer reaches zero, a buzzer will sound.
- (8) Turn the Timer knob to "O" position.
- (9) Turn the thermostat knob to the desired hold temperature.
- (10) Remove the product from the oven when done.

Optional steam injection Rotary control:

The solenoid valve for steam injection is mounted behind the service panel on the right-hand side of the unit. The electronic timer is preset at the factory. A ¼" copper tubing is provided on the Solenoid Valve for water hookup with a compression fitting. After the water hookup is made, make sure that there are no leaks. For steam injection, press the Steam switch momentarily.

NOTE: DO NOT USE STEAM INJECTION AT TEMPERATURES BELOW 275°F (135°C).

Oven cool down Rotary control:

To cool down the oven to a lower desired temperature, follow the steps detailed below.

- (1) Open the oven doors.
- (2) Turn Selector Switch to "oven cool down" position. Fan will now operate and cool down the oven.
- (3) When the oven has cooled down to the desired temperature, turn the Selector Switch to "O" position. Close oven doors.

IMPORTANT FOR FUTURE REFERENCE

Please complete this information and retain this manual for the life of the equipment. For Warranty Service and/or Parts, this information is required.

 Model Number

 Serial Number

 Date Purchased

CLEANING

Always clean equipment thoroughly before first use. Clean unit daily.



WARNING: To avoid any injury, turn the power switch off at the fuse disconnect switch/circuit breaker or unplug the unit from the power source and allow to cool completely before performing any maintenance or cleaning.



WARNING: Unit is not waterproof. To avoid electrical shock or personal injury, **DO NOT** submerge in water. **DO NOT** operate if it has been submerged in water. **DO NOT** clean the unit with a water jet. **DO NOT** steam clean or use excessive water on the unit.



CAUTION: Use mild detergent or soap solution for best results. Abrasive cleaners could scratch the finish of your unit, marring it's appearance and making it susceptible to dirt accumulation. **DO NOT** use abrasive cleaners or cleaners/sanitizers containing chlorine, iodine, ammonia or bromine chemicals as these will deteriorate the stainless steel and glass material and shorten the life of the unit. Use nylon scouring pads. **DO NOT** use steel wool.



OVEN INTERIOR:

Clean The Racks And Rack Support Guides:

Open the doors and remove all wire racks and rack support guides. Take them to the sink and thoroughly clean in warm water with mild detergent or soap. Use a nylon scouring pad or stiff nylon brush.

DO NOT USE STEEL WOOL.

Clean The Stainless Steel Interior:

Baked on splatter, oil, grease or discoloration on the stainless steel inside of the oven may be removed with stainless steel cleaner, or any other similar cleaning agent. **NEVER** use vinegar or any corrosive cleaner. Use only cleaners approved for stainless steel. **NEVER** use cleaning solvents with a hydrocarbon base. **NEVER** use a wire brush, steel or abrasive scouring pads, scraper, file or other steel tools.

NOTE: ALWAYS RUB THE STAINLESS STEEL ALONG THE GRAINS.

Clean The Blower Wheel:

To clean the blower wheel, remove and immerse in ammoniated water for 20 to 25 minutes. Then, scrub it off with a small, stiff brush. The same procedure can be followed for wire racks and rack supports. To remove the blower wheel, loosen the set screws (2) on the hub of the blower wheel and tighten the 3/8" wheel puller bolt (supplied) in center of hub (See Fig. 1).

Clean The Porcelain Interior:

Porcelain enamel interiors are designed to be as maintenance free as possible. However, for best results, the oven should be cleaned regularly. Enameled interiors can be easily cleaned with oven cleaners. **KEEP CLEANING FLUIDS AWAY FROM ELECTRICAL WIRES, LIGHT SOCKETS, SWITCHES AND CONTROL PANEL.**

OVEN EXTERIOR:

Clean The Exterior Stainless Steel:

To remove normal dirt or product residue from stainless steel, use ordinary soap and water (with or without detergent) applied with a sponge or cloth. Dry thoroughly with a clean cloth. Never use vinegar or corrosive cleaner. Do not use chlorine based cleaners.

To remove grease and food splatter or condensed vapors that have baked on the equipment, apply cleaners to a damp cloth or sponge and rub cleanser on the metal in the direction of the polished lines on the metal. Rubbing cleanser as gently as possible in the direction of the polished lines will not mar the finish of the stainless steel. To remove discoloration, use a non-abrasive cleaner. **NEVER** use a wire brush, steel or abrasive scouring pads, scraper, file or other steel tools. **NEVER RUB WITH A CIRCULAR MOTION.**

Figure 1

Cleaning The Blower Wheel

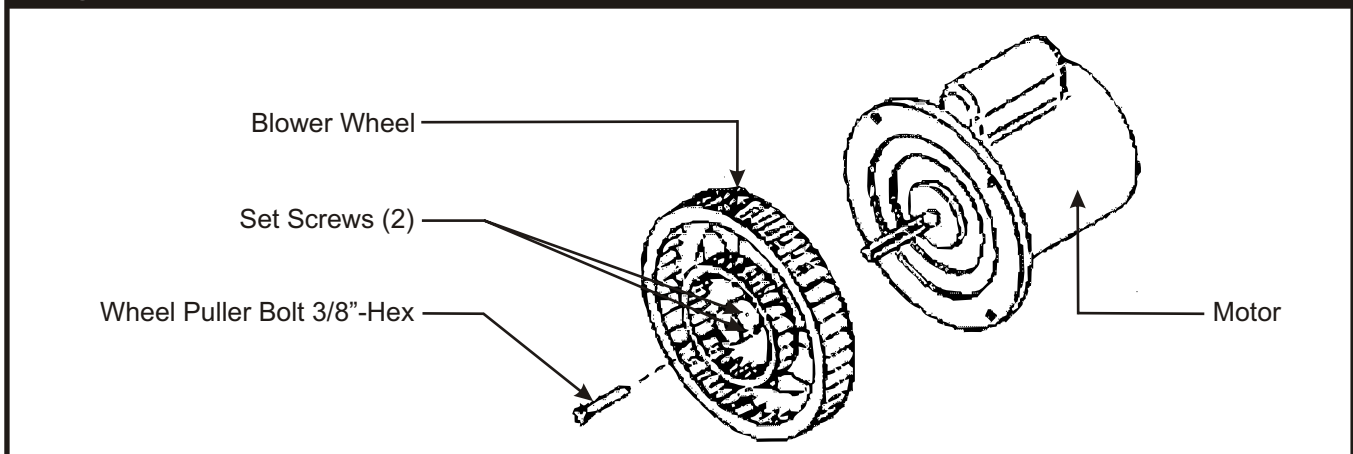

D. SERVICING:

NOTE: THIS APPLIANCE MUST BE SERVICED BY AN AUTHORIZED SERVICE AGENT.

- (1) Power supply to the unit must be disconnected before any service is performed.
- (2) Most of the service on the unit can be performed from the front and/or control panel side.
- (3) For proper servicing, access to the control panel side of the unit will be required.
- (4) It will be necessary to have access to the back of the oven for service needs related to the electric power supply.
- (5) A system wiring diagram is provided in this manual and on the back of the service panel on the right side of the oven.
- (6) All servicing should be performed by a factory-authorized technician only.
- (7) For proper maintenance and repairs, call the factory toll free (800-972-6887) for an authorized service agency in your area.

WARNING: RISK OF FIRE. When stacked two high maximum, use stacking kit part #E3771A only.

CAUTION: This product, when stacked, has more than one power-supply connection point. Disconnect all power supplies before servicing.

Figure 2 OPEN RACK STAND ASSEMBLY INSTRUCTIONS: COB-E & COM-E

- 770504**
Lock Nut 1/4-20 (12)
- 8507600**
Washer, Flat 1/4" (12)
- 8205500**
Screw, 1/4-20 X 1/2 (12)
- 21816807**
Support, Wire Rack (2)
- 770504**
Lock Nut 1/4-20 (12)
- 21818234**
Undershelf, Gas Oven (1)
- 8205500**
Screw, 1/4-20 X 1/2 (12)

Assembly Instructions

- 1: Place undershelf between legs & secure with 1/4-20 UNC screw, flat washer & locknut. The holes for mounting the wire racks should be toward the front of the oven.
- 2: Place open rack supports between legs and secure with 1/4-20 UNC screw, flat washer and locknut.
- 3: Slide open wire racks into position using the holes in the undershelf as a guide.

Figure 3 STACKING INSTRUCTIONS FOR: COB-E & COM-E CONVECTION OVENS

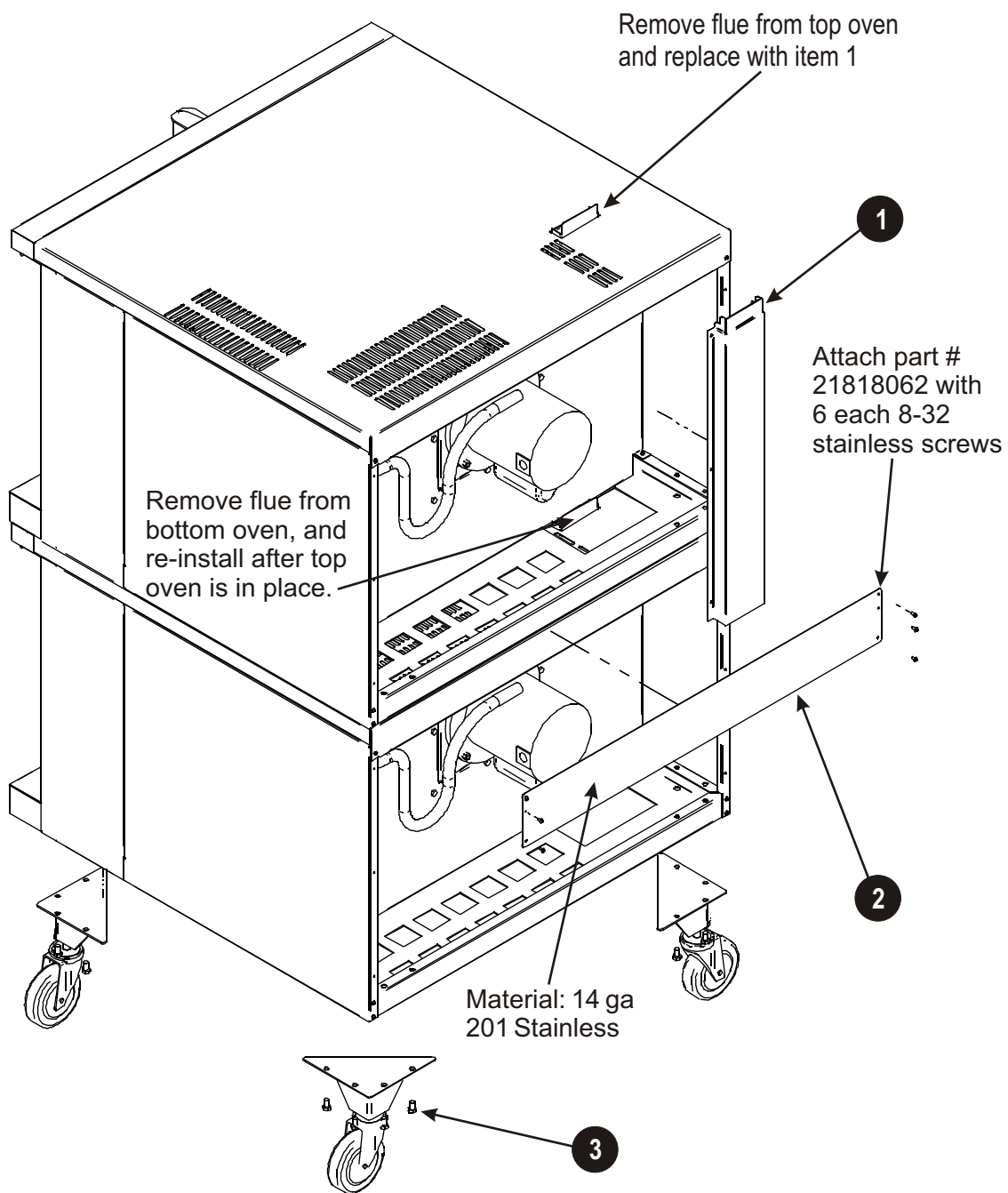

Item 1	Item 2	Item 3
 <p data-bbox="402 1921 521 1955">E3770A</p>	 <p data-bbox="849 1921 967 1955">E3771A</p>	 <p data-bbox="1206 1921 1377 1955">3/8"-16 Bolt</p>

Figure 4

LEG ASSEMBLY INSTRUCTIONS - MODEL: COB-E & COM-E

WITH PLATE CASTER

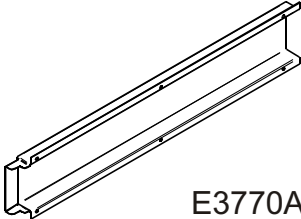
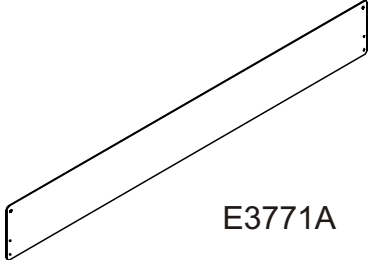
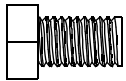
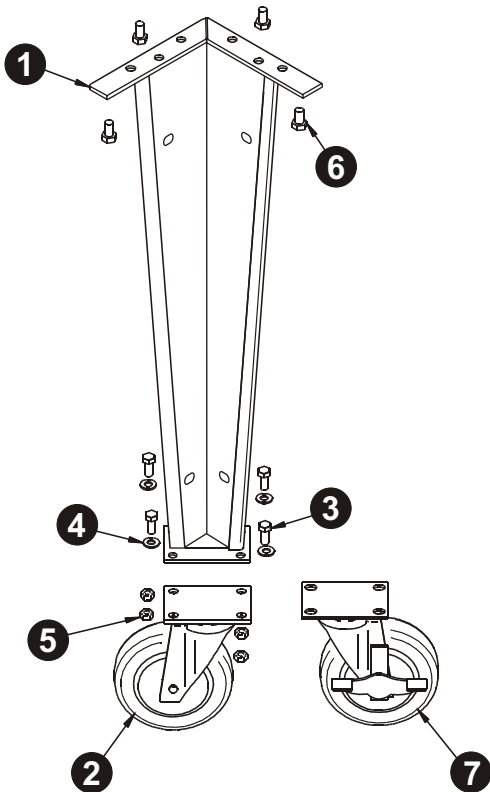

Item	P/N	Description
1	21796810	Weldment, Oven Leg
2	8633102	Caster, 5" Swivel W/Top Plate
3	8227700	Hex Hd 5/16-18 X 3/4 Bolt #5 Zn
4	8509300	Washer, Flat SAE, 5/16
5	8435000	Hex-nut 5/16-18
6	82447-00	Hex Hd. 3/8-16 X .750 #5
7	8633101	Caster, 5" Swivel W/Plate & Brake

1. Attach two item 2 to two item 1 using item 3, 4 and 5.
2. Attach two item 7 to two item 1 using item 3, 4 and 5.
3. Using proper lifting equipment attach item 1 to the corresponding hole patterns located in the bottom of the oven with item 6.

WITHOUT PLATE CASTER

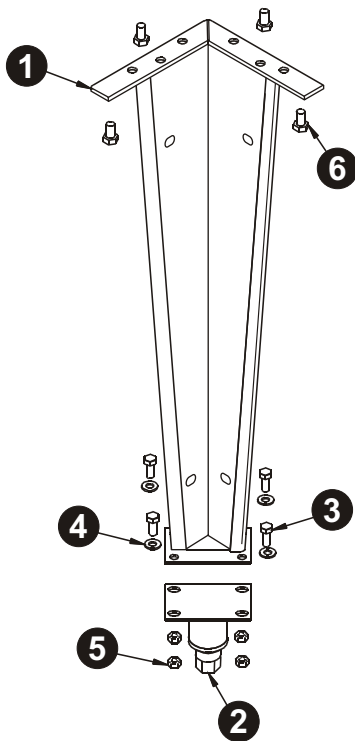

Item	P/N	Description
1	21796810	Weldment, Oven Leg
2	8633515	Foot Insert, Adjustable
3	8227700	Hex Hd 5/16-18 X 3/4 Bolt #5 Zn
4	8509300	Washer, Flat, SAE, 5/16
5	8435000	Hex-Nut 5/16-18
6	82447-00	Hex Hd. 3/8-16 X .750 #5

1. Attach four item 2 to four item 1 using item 3, 4 and 5.
2. Using proper lifting equipment attach item 1 to the corresponding hole patterns located in the bottom of the oven with item 6.

COB-E & COM-E 208, or 240VAC, 1 Phase (Dial Control)

E. WIRING DIAGRAMS

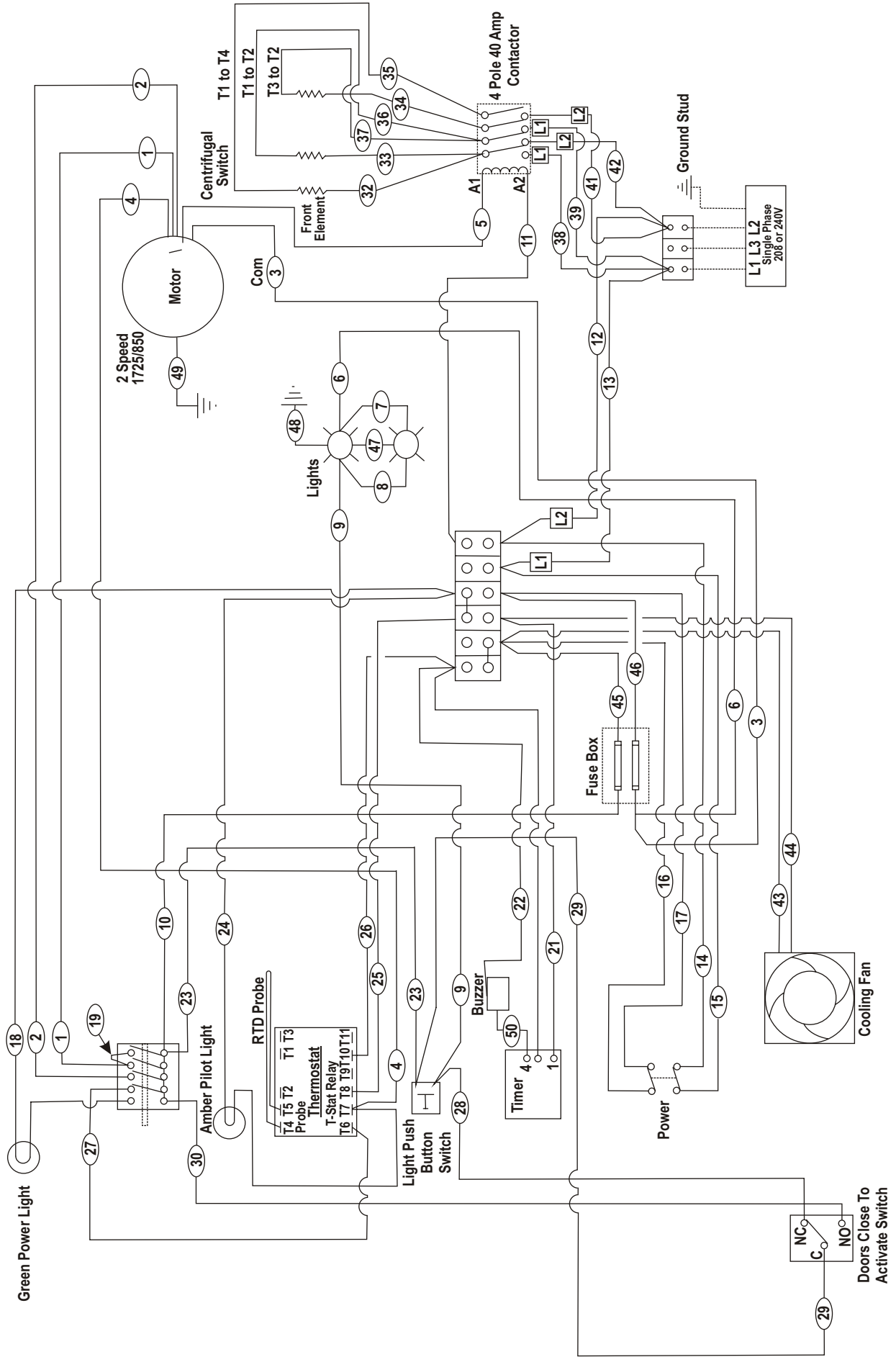

COB-E & COM-E 208, or 240VAC, 3 Phase (Dial Control)

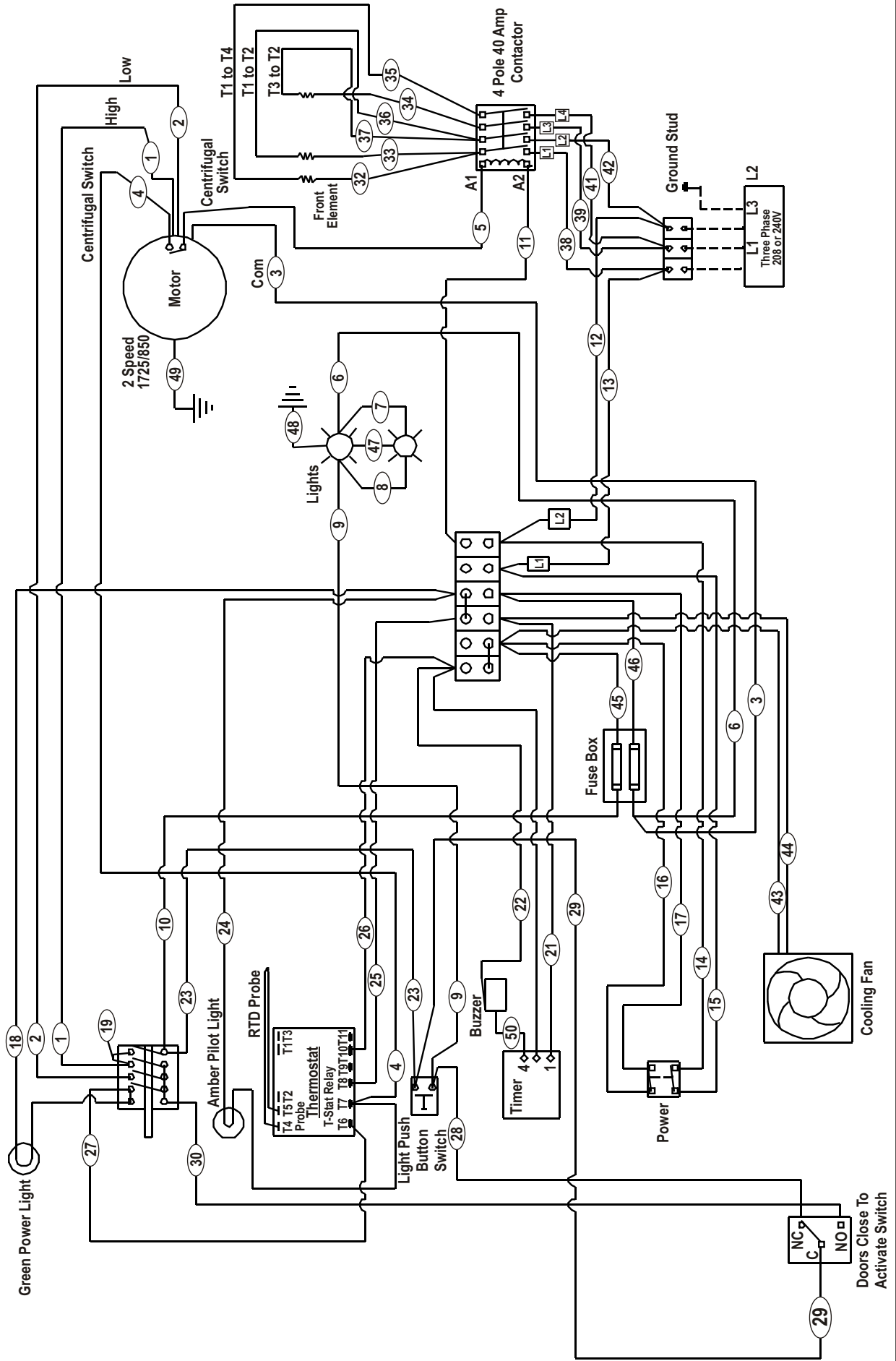

Single Phase 208V or 240V Wiring Diagram (CH-100 Control)

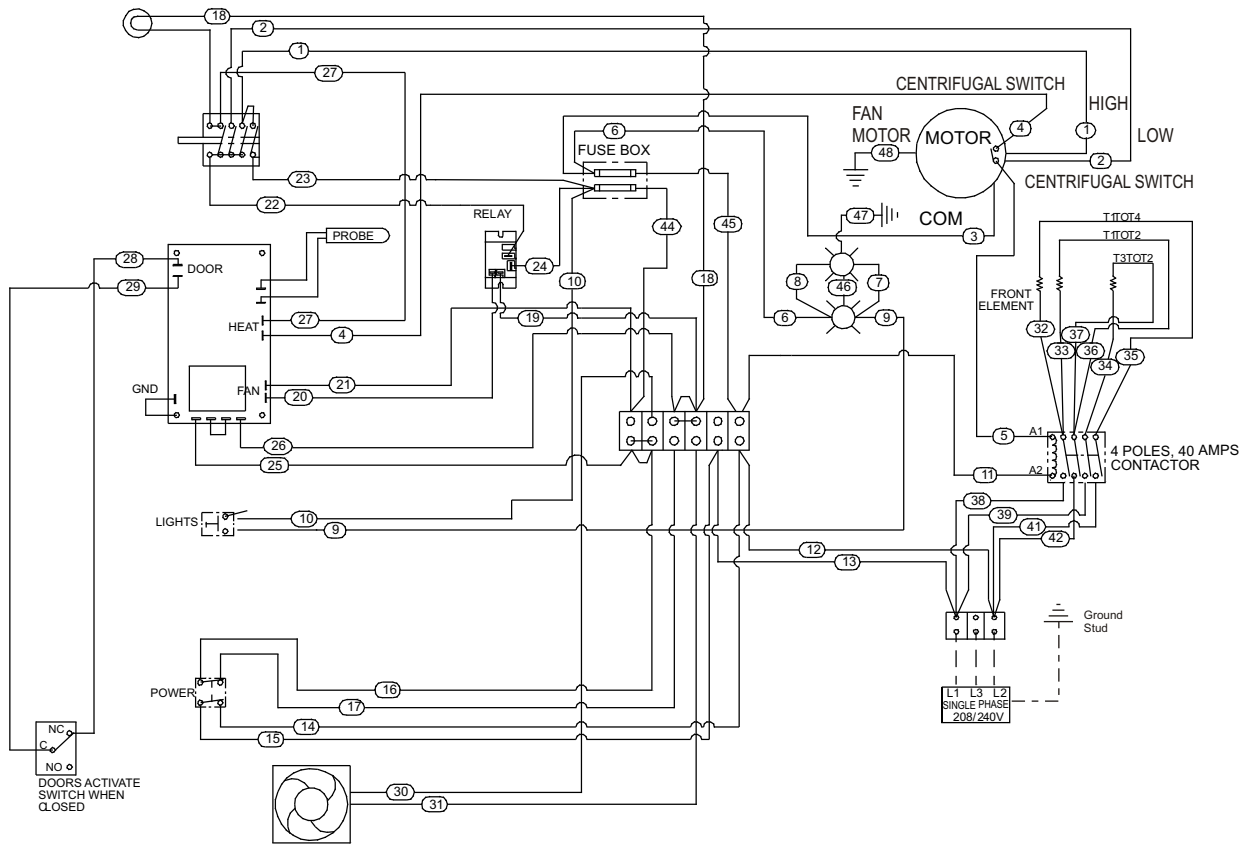

Three Phase 208V or 240V Wiring Diagram (CH-100 Control)

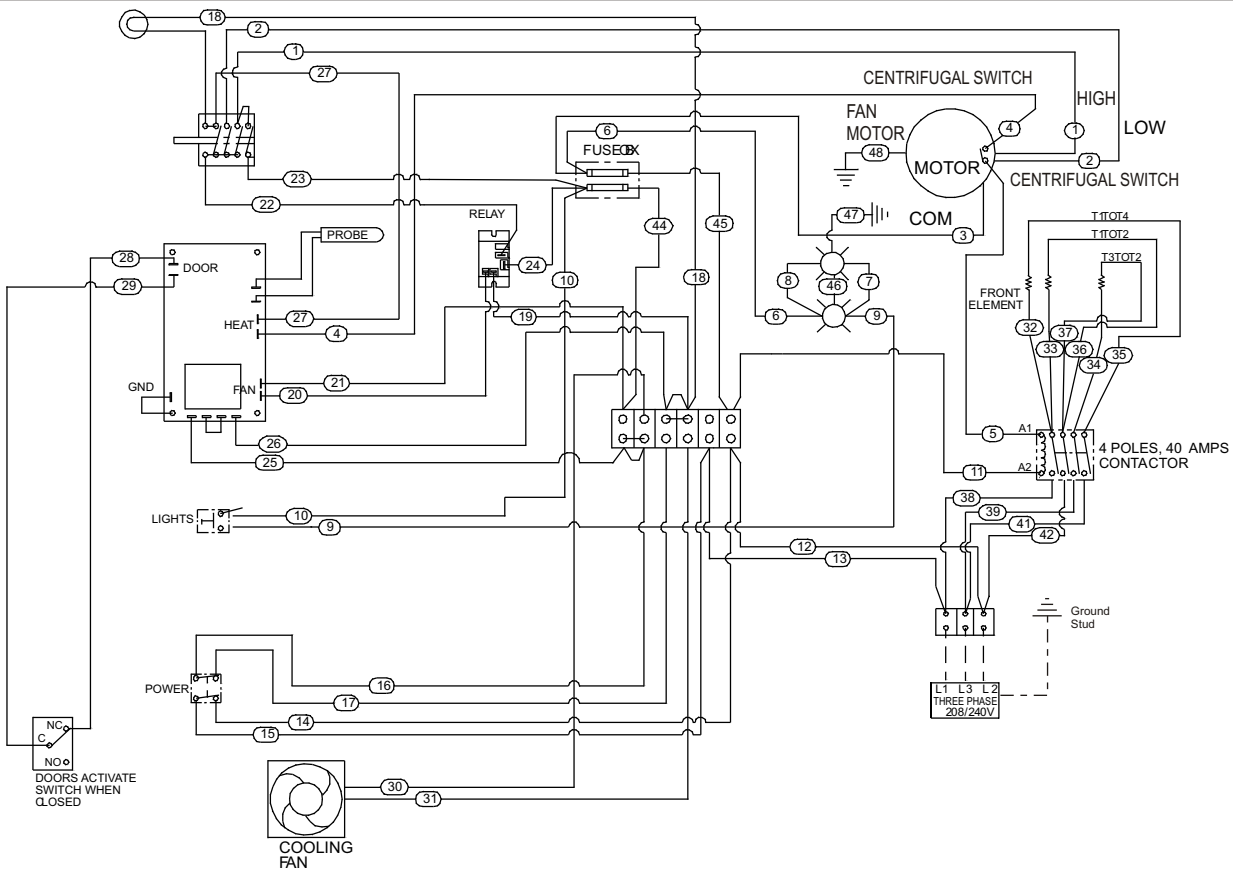

F. PARTS LIST w/EXPLODED VIEW COB-E & COM-E CONVECTION OVEN

Steam Option (Not Shown)		Kits (Not Shown)	
PIN	Description	PIN	Description
M1114X	Solenoid Valve	E8752A	Kit, 25" Legs, Black w/3" Adj Feet
M1115X	Coil (For Solenoid Valve)	E8753A	Kit, 25" Legs, Black w/Plate Casters
N3039A	1/8 Brass Coupling	E8754A	Kit, 25" Legs, S/S w/3" Adj Feet
N3040A	1/8 Brass Elbow	E8755A	Kit, 25" Legs, S/S w/Plate Casters
N5831A	1/8x4" Brass Nipple	E8756A	Kit, Stacking, w/6" Adj Legs
N3041A	1/8NPT-1/4 Compression Fitting	E8759A	Kit, Stacking, w/Plate Casters
N5814A	1/8x2 3/8 Nipple		
N5815A	1/4 Tubing x 9"		
N1019X	Steam Injection Nozzle		
M1231A	Steam Timer, 208/230V		
M1176X	Steam Potentiometer		
M1049X	Momentary Switch (Steam)		

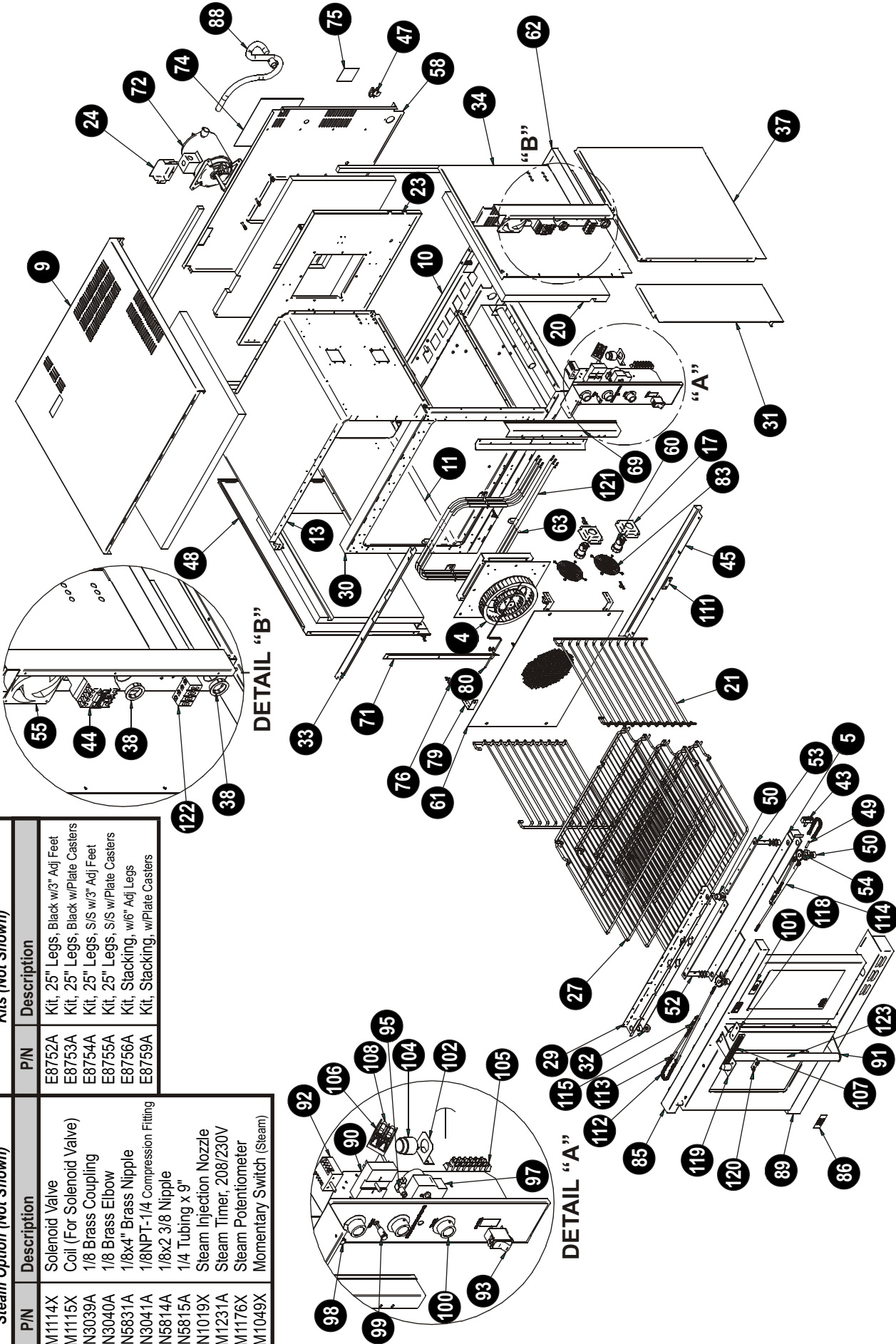

ITEM	P/N	DESCRIPTION	QTY	ITEM	P/N	DESCRIPTION	QTY
1*	81300-00	8-32 X 3/8 Type T	118	63	21816870	Support, Element	6
2*	8410400	Nut, Hex, 8-32 S/S	12	65*	21816868	Motor Panel	1
3	21816853	Support, Lower Back Liner	1	66*	21816844	Motor Mount	1
4	1200500	Fan, Wheel In Wheel Blower	1	67*	8354000	Pop Rivet, Ø.125 X .297	22
5	21816859	Bottom Channel	1	68*	84252-00	Nut, Hex, 1/4-20 SS	10
6*	21818043	Leg Mount	4	69	21816835	Front Cover	1
7*	8162500	M/S #10-32 Truss Hd	6	70*	8435000	Hex-nut 5/16-18 ZN	12
8*	43813149	Label, Warning Hot Surface (French)	1	71	21816864	Seal, Left & Right Door	2
9	218168-40	Panel, Top Outer	1	72	1219600	Motor 200-230v 850/1725 RPM	1
10	21816854	Pan, Base	1	73*	43813103	Label, Wiring, Hot Surface	1
11	21816841	Chamber, Oven Lower	1	74	8806650	Label, Elec Oven 3 Ph 208/240V Schematic	1
12*	81408-00	8-32 X 1/2 MS	12	75	8861000	Label, Spec	1
13	21816842	Bake Liner Upper	1	76	21816865	Support, Side Rack	8
14*	21816877	Cover, w/Cut-Out	1	77*	1000900	Sleeve, Fibgls, #3 Wire X .020wl	1
15*	21816869	Base, Cover w/Cut-Out	1	78*	8967200	Bushing, Snap .375 ID .5 Hole Nylon Black	1
16*	82306-00	5/16-18 X 1.25 Bolt Hx	4	79	218168-20	Bracket, Baffle	4
17	21816875	Support, Small Light	2	80	1400120	RTD Probe	1
18*	218180-47	Insulation, Bottom Conv Oven	2	81*	89456-00	Clamp-Loop 3/16"	1
19*	8508100	Lock Washer Ext 1/4	6	82*	21818033	Spacer, Probe	1
20	218180-46	Insulation, R.H. Side	1	83	31007-33	Guard, Fan Finger	2
21	21816807	Support, Wire Rack	2	84*	8203400	M/S Ft Hd Ph 1/4-20x 5/8 ZN	4
22*	218180-45	Insulation, L.H. Side	1	85	21816851	Trim, Top	1
23	21816813	Bake Liner, Back	1	86	8825300	Decal, Leg	1
24	21816871	Flue, End	1	87*	81759-00	10-32 X 1/2 Tr Hd	4
25*	218180-48	Insulation, Top	1	88	21816899	Conduit 1" 36" Long	1
26*	218180-44	Insulation, Back	1	89	21816850	Trim, Bottom	1
27	21816806	Rack, Full Size	5	90	21816883	Control Panel, Basic W/Assembly	1
28*	21818049	Insulation, Filler	4	91	21816827	Door,60 w/Window Assy	1
29	21816858	Support, Top Door	1	92	1300210	Switch, 4 Pos Rotary	1
30	21816857	Frame, Front	1	93	1300220	Switch, Rocker DPST	1
31	21816833	Insert, Control Panel	1	94*	21809210	Decal, Black & Red w.o./Steam	1
32	21818037	Spacer Door	2	21809220	Decal, Black & Red w/Steam	1	
33	21816896	Seal, Top	1	95	1300230	Switch, Push Button	1
34	21816863	Retainer, Right Insulation	1	96*	1400110	Thermostat, Fastron G6	1
35*	8211100	Screw, Mach 1/4-20 X 3/4	4	97	1400130	60 Min Timer	1
36*	82447-00	Hex Hd. 3/8-16 X .750 #5	33	98	1509600	Pilot Light Green (Power)	1
37	218168-62	Panel, Right Outer	1	99	45653000	Light, Indicator 250V, 1/2" Dia. Amber	1
38	89671-00	Bushing, Snap 1.312 I.D.	2	100	8704600	Knob	3
39*	21816861	Baffle, Control Panel	1	101	88250-00	Decal, Caution Disconnect	1
40*	21818034	Spacer, Insulation	8	102	21816895	Bracket, Buzzer	1
41*	21818040	Tube Cord Tube Weldment	1	103*	21816825	40 Door w/Window	1
42*	8357600	Rivet, 3/16 X 3/8 AI	84	104	1400140	Audio Alarm	1
43	1300240	Switch, Door	1	105	11072-00	Block Terinal, 6 Station 600V	1
44	M1030X	208V Contactor	1	106	1504800	Holder, Fuse 15A 600V	1
	1300205	240V Contactor	1	107	U1451A	Nameplate, BKI 8"	1
45	21816897	Seal, Bottom Door	1	108	3110007	Fuse,300V,15A	2
46*	11019-00	Connector, 1/2" Flex Straight	2	109*	8172400	M/S Ft Hd PH 10-32x1/2 SS	4
47	5161000	Connector Cable Romex	1	110*	21816834	Support, Door	1
48	21816852	Panel, Left Outer	1	111	21816832	Stop, Door	1
49	8400450	Roll Pin .250 X 1.250 (COM Only)	2	112	21816804	Chain, Roller #35 (COM Only)	2
50	8400430	Flange Bearing (COM Only)	6	113	21816816	Short Eye Hook (COM Only)	2
51*	8400420	Thrust Bearing	4	114	21816814	Long Eye Hook (COM Only)	2
52	21816819	60 Arm Weldment	1	115	84004-10	Turnbuckle, 1/4-20 (COM Only)	2
53	21816821	Arm, 40 Weldment	1	116*	8400440	Nut, Hex, Lt Hand 1/4-20 SS (COM Only)	2
54	218168-05	Sprocket, Door (COM Only)	2	117*	82082-00	1/4-20 X .75 Tr Hd	2
55	1215400	Fan W/ Motor	1	118	21816843	Plate, Cover	1
56*	21816810	Switch Cam	1	119	8716100	Catch, Roller (COM Uses1, COB Uses 2)	1
57*	81357-00	Screw, 8-32 X 3/8" Ft Hd	5	120	21818019	Plate, Striker (COM Uses1, COB Uses 2)	1
58	21816860	Retainer Back Insulation	1	121	L6803A	Element, 208 V, 3333W	3
60	1400150	Assy, Snap In Light 230V/15W	2		L6809A	Element, 230 V, 3333W	3
61	21816892	Baffle, Oven	1	122*	1107500	Block, 4 Pole Terminal, 85 Amp	1
62	21818075	Pan Cover	1	123	S6808A	Handle Assy (COM Uses1, COB Uses 2)	1

* = NOT SHOWN



BKI LIMITED WARRANTY

PO Box 80400 Simpsonville, SC 29680-0400 USA
(864) 963-3471 ♦ Toll Free: (800) 927-6887 ♦ Fax: (864) 963-5316

WHAT IS COVERED	This warranty covers defects in material and workmanship under normal use, and applies only to the original purchaser providing that: <ul style="list-style-type: none">♦ The equipment has not been accidentally or intentionally damaged, altered or misused;♦ The equipment is properly installed, adjusted, operated and maintained in accordance with National and local codes, and in accordance with the installation instruction provided with the product;♦ The serial number rating plate affixed to the equipment has not been defaced or removed.
WHO IS COVERED	This warranty is extended to the original purchaser and applies only to equipment purchased for use in the U.S.A.
COVERAGE PERIOD	Convection Ovens: COB Models: One (1) Year limited parts and labor; COM Models: Two (2) Year limited parts and labor; COI Models: Two (2) Year limited parts and labor; (5) Year limited door warranty. Warranty period begins the date of dealer invoice to customer or ninety (90) days after shipment date from BKI - whichever comes first.
WARRANTY COVERAGE	This warranty covers on-site labor, parts and reasonable travel time and travel expenses of the authorized service representative up to (100) miles, round trip, and (2) hours travel time.
EXCEPTIONS	The extended door warranty years 3 through 5 is a parts only warranty and does not include labor, travel, mileage or any other charges.
EXCLUSIONS	<ul style="list-style-type: none">♦ Negligence or acts of God,♦ Thermostat calibrations after (30) days from equipment installation date,♦ Air and Gas adjustments,♦ Light bulbs,♦ Glass doors and door adjustments.♦ Fuses,♦ Adjustments to burner flames and cleaning of pilot burners,♦ Tightening of screws or fasteners.♦ Failures caused by erratic voltages or gas supplies,♦ Unauthorized repair by anyone other than a BKI Factory Authorized Service Center,♦ Damage in shipment,♦ Alteration, misuse or improper installation,♦ Thermostats and safety valves with broken capillary tubes.♦ Freight - other than normal UPS charges,♦ Ordinary wear and tear.
INSTALLATION	Leveling, as well as proper installation and check out of all new equipment - per appropriate installation and use materials - is the responsibility of the dealer or installer, not the manufacturer.
REPLACEMENT PARTS	BKI genuine Factory OEM parts receive a (90) day materials warranty effective from the date of installation by a BKI Factory Authorized Service Center.

This Warranty is in lieu of all other warranties, expressed or implied, and all other obligations or liabilities on the manufacturers part. BKI shall in no event be liable for any special, indirect or consequential damages, or in any event for damages in excess of the purchase price of the unit. The repair or replacement of proven defective parts shall constitute a fulfillment of all obligations under the terms of this warranty.

Form #U4177A-BKI 7/07