

(12 dia.)



Push type



Lock type

FEATURES

1. High performance and excellent characteristics.

An AH7 snap action switch is used in the switch body and since the installation frame is made of molded plastic, dimensional accuracy is now on a new level.

2. Two series: push type and lock type

Lock type also available that locks when rotated.

3. Six push-button colors

You can use colors in accordance with sequence functions.

4. The switch body uses an AH7 snap action switch (O.F. 3.92 N max. type).

Also, if dirt and water resistant properties are required of the internal switch, a V type turquoise switch (sealed type snap action switch) can be built in. Please inquire.

PRECAUTIONS WHEN USING CADMIUM-FREE CONTACT TYPE

Models with cadmium-free contacts have been introduced in order to reduce environmentally harmful substances. ("F" is affixed to the end of the part number.)

We ask customers who are currently using products with cadmium-containing contacts (no "F" at the end of the part number) to please make the switch to models with cadmium-free contacts.

When switching, operating life may differ depending on the load. Please be sure to verify this by conducting an evaluation using actual equipment.

RoHS Directive compatibility information
<http://www.nais-e.com/>

PRODUCT TYPES

Type	Part No.	Push-button color (Number replaces asterisk in part number.)					
		Black	Red	Green	Yellow	White	Blue
Push type	AB5*2177F	1	2	3	4	5	6
Lock type	AB5*2277F	1	2	3	4	5	6

SPECIFICATIONS

1. Contact rating

Kind of load	AC rating	DC rating
Resistive load (cos nearly equal 1.0)	15A 125V AC, 15A 250V AC	0.6A 125V DC
Inductive load (cos nearly equal 0.4)	10A 125V AC, 10A 250V AC	0.6A 125V DC

2. Characteristics

Expected life	Mechanical	Min. 10 ⁷ (60 cpm)
	Electrical	Min. 10 ⁵ (20 cpm) at rated load
Insulation resistance		Min. 100 MΩ (at 500 V DC measured by insulation resistive meter)
Breakdown voltage	Between non-continuous terminals	1000 Vrms for 1 min. (at detection current: 10mA)
	Between each terminal and other exposed metal parts	1500 Vrms for 1 min. (at detection current: 10mA)
	Between each terminal and ground	1500 Vrms for 1 min. (at detection current: 10mA)
Contact resistance		Max. 50 mΩ (By voltage drop at 1 A, 6 to 8 V DC)
Allowable operation speed (No load)		0.1 to 1,000 mm/s
Max. switching frequency (No load)		600 cpm
Ambient temperature		-25°C to +85 °C (Not freezing below 0 °C)
Contact material		Movable: AgSnO ₂ alloy; Fixed: AgZnO alloy

DIMENSIONS (mm) (General tolerance: ± 0.4)

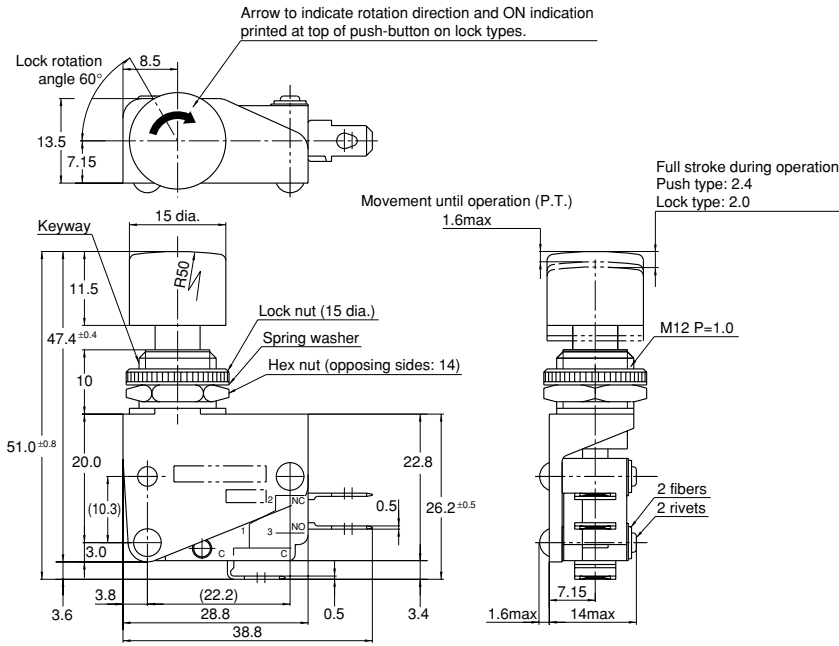

Mounting dimensions
(Panel thickness: Max. 3 mm)

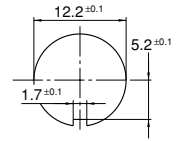

NOTES

1. For panel installation, please tighten with a torque of no more than 1.47 N·m.
2. For push-button installation, please tighten with a torque of no more than 0.49 N·m.
3. Notch is provided on the operation shaft and pushbutton to prevent the push-button from falling off. After using the notch, screw in a further 120 to 160° (3 or 4 threads).
4. Please note that the number changes when the push-button is replaced.