

# 17"/19" TFT-LCD Monitor

## SMT-1723/1923

### Features

- 620(PAL)/600(NTSC) Horizontal TV Lines
- DNLe(Digital Natural Image engine)
- 1000:1 High Contrast Ratio
- 300cd/m<sup>2</sup> High Brightness
- 5ms Response Time
- 1280x1024 Resolution
- BNC, S-Video, VGA Input
- Built-in Speakers
- Tempered Glass
- VESA 100 Mount Compatible
- 3 way adjustable stand

### Dimensions(mm)

#### SMT-1723

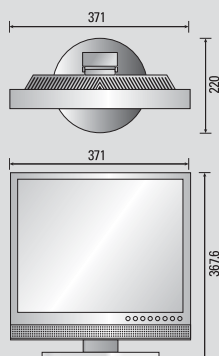

#### SMT-1923

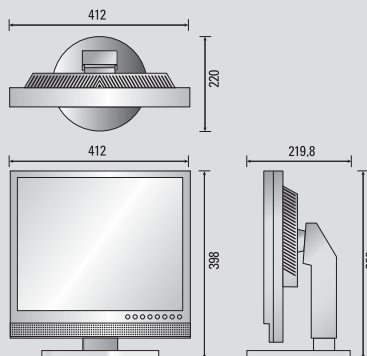

### Specifications

Model		SMT-1723	SMT-1923
Sync Format		NTSC/PAL	
	Inch	17"	19"
Panel	Resolution	1280 X 1024	
	Brightness(cd/m <sup>2</sup> )	300	
	Contrast	1,000:1	
	Response Time	5msec	
	Viewing Angle Degree	80/80/80/80	
	Active Display Area(mm)	338 x 270(H x V)	376 x 301(H x V)
	CCFL Lifetime	50,000 hour	
Feature	Scan System	Progressive	
	Horizontal Resolution	620TVL (PAL), 600TVL (NTSC)	
	Screen Mode	4:3	
	3D Comb Filter	Yes	
	Noise Reduction	Yes	
	PIP/PBP	Yes	
	Freeze	Yes	
	Under Scan	Yes	
Video	Composite	2Ch input, Loop Through out, BNC Type	
	S-Video	1Ch input(Y/C), Loop Through out	
	VGA	1Ch input	
Audio		2Ch input, 2W Stereo, RCA Type	
OSD	Language	11 Language (Eng/Fre/Ger/Spa/Ita/Rus/Swe/Por/Kor/Chn/Jpn)	
Height Adjustable Stand	Lift	0 ~ 100mm	
	Tilt	-5° ~ 23°	
	Swivel	-165° ~ +165°	
Weight		5.8Kg	6.8Kg
Dimensions(mm)		371 x 368 x 220 (W x H x D / Lowest)	412 x 398 x 220 (W x H x D / Lowest)
		371 x 468 x 220 (W x H x D / Highest)	412 x 498 x 220 (W x H x D / Highest)
Power Supply (Included)		DC 12V external power supply	
Power Consumption		42W	42W

\*Design and Specifications are subject to change without notice



\* Design and specifications are subject to change without notice

SAMSUNG ELECTRONICS CO., LTD.

416, Maetan 3 Dong, YeongTong-Gu, Suwon City, Kyeonggi-Do, Korea, 443-742  
Tel: +82-31-277-3342-3347 Fax: +82-31-277-6597 <http://www.samsungsecurity.com>

Distributed by



SMT-1723/1923

**imagine** the outstanding image quality with super high resolution!

Give the people that protect you and your property the best tools to do their job. The SMT-1723/1923 provides your security personnel with the best images available to ensure that even the smallest detail is not missed.

**SAMSUNG**  
ELECTRONICS



Beyond imagination! The ultra sharp screen with super high resolution clearly displays even a bead of perspiration!

## • : SMT-1723/1923 17"/19" TFT-LCD Monitor

### Fast Response Time

With a response time of 5ms ghosting and jagged pixel effects are greatly reduced, resulting in superb image clarity even when monitoring scenes with high speed activity.



conventional



5ms

### Tempered Glass Screen

SMT-1723/1923's tempered glass screen design protects the screen from dirt, repetitive touching or scratching.



### PIP (Picture in Picture), PBP (Picture by Picture)

The picture-in-picture or picture-by-picture capability allows a security manager to use a PC and view a CCTV camera at the same time. It could also allow the manager to always have a video of important camera in the corner at all times.



PIP (Picture in Picture)



PBP (Picture by Picture)

### Audio output in VGA Mode

Users can select an audio output in VGA mode from any of the audio inputs.

### Multiple Connections

Based on different surveillance needs, a combination of different video/audio ports can be used for a more integrated solution.

### Height Adjustable Stand (HAS)

SMT-1723/1923 monitor can be adjusted to your comfort level. Maximize your efficiency with the convenient height adjustable stand.

