

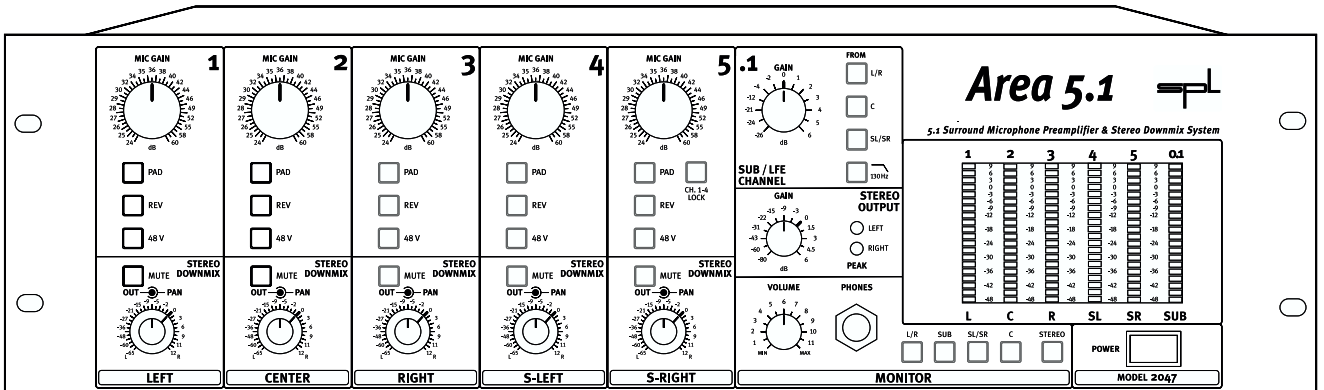

soundperformancelab.com



Area 5.1

5.1 Surround Microphone Preamp & Stereo Downmix System

Manual

Version 1.0 - 5/2000

The information in this document has been carefully verified and is assumed to be correct. However Sound Performance Lab (SPL) reserves the right to modify the product described at any time. Changes without notice. This document is the property of SPL and may not be copied or reproduced in any manner, in part or full without the authorization of SPL.

Limitations of Liability:

In no event will SPL be liable for any damages, including loss of data, lost profits, cost of cover or other special, incidental, consequential or indirect damages arising from the use of the unit, however caused and on any theory of liability. This limitation will apply even if SPL or an authorized dealer has been advised of the possibility of such damage.

Sound Performance Lab

P.O. Box 12 27

D- 41368 Niederkrüchten, Germany

Phone +49 - 21 63 / 98 34-0

Fax +49 - 21 63 / 98 34-20

eMail: info@soundperformancelab.com

www.soundperformancelab.com



Introduction	3
Feature List	7
Installation	4
Standard Recording Setup	4
SPL Mic Array	6
Operation	
Preamplifier	6
Sub/LFE channel	7
Stereo downmix stages	8
Stereo output	8
Monitoring	8
Output PPM meter	8
Power Supply	9
Specifications	9
Warranty	10
Notes	11

Dear customer,

congratulations on choosing the Area 5.1 for producing your 5.1 recordings. We are sure you have as much pleasure using it as we had making it.

The complete Area 5.1 system contains the Area 5.1 unit and optionally the SPL mic array and a multicore cable. Though the Area 5.1 unit could be used with any microphone setup, the combination with the SPL mic array is recommended since it is the first proven standard setup to capture three-dimensional sound images in all recording situations.

This authentic approach in terms of human perception also minimizes the efforts to set up an 5.1 microphone installation. Another essential feature is the stereo downmix stage that allows to record both stereo and 5.1 simultaneously.

Since the Area 5.1 constitutes an electroacoustical system in highest degrees of complexity, there are a few things to mention. This manual contains basic informations regarding setup, connections, first placing in operation and control elements.

Introduction

Installation

The Area 5.1 unit should not be installed near units which produce strong magnetic fields or extreme heat. Do not install the unit directly above or below power amplifiers. Generally choose a place with sufficient air circulation.

The mic array has to be placed the way that the LCR heads (those closer to the microphone center/90° angle) are facing the sound source. Be aware that placing the mic array close to the ground may result in ground reflections and comb filtering effects. The best horizontal position for the mic array is right on the crossing between the direct sound field and the diffuse sound field.

Connect all devices **BEFORE** switching on the Area 5.1

BEFORE switching on power, make sure that the microphones are connected with the Area 5.1 unit. (optional multicore lead recommended). Check that the voltage details quoted on the back panel are the same as your local mains electricity supply. Use a minus (-) screwdriver to set the voltage selector to the required voltage.

NOW switch on the Area 5.1. Chassis ground and AC ground can be disconnected by the "Ground Lift" switch (GND LIFT) on the back panel, if hum problems occur. An AC power cord is included to feed the IEC-spec, 3-prong connector.

After switching on the Area 5.1, proceed as follows:

- 1) Press the Ch. 1-4 Lock button of channel 5.
- 2) Turn the Mic Gain control of channel 5 clockwise until sufficient recording level is indicated at the PPM output meters (all other mic gain controls follow precisely)

Standard Recording Setup

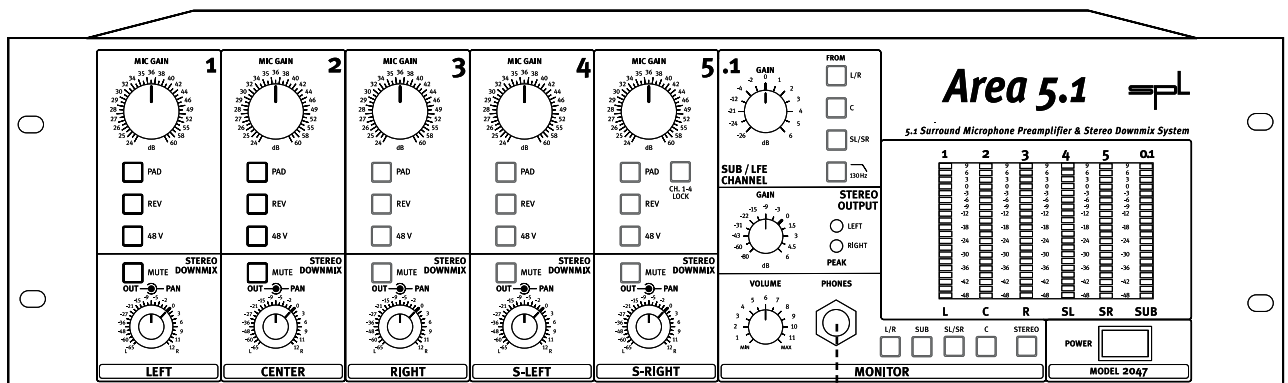

See chapter Operation/Monitoring, page 8, for further information on stereo headphone monitoring



Standard Recording Setup

The Standard Recording Setup is the basic configuration for recordings with the Area 5.1. Generally any digital or analog recording system can be connected to the analog 1/4" unbalanced jack or balanced XLR outputs of the Area 5.1.

If, for example, an eight-track DTRS is used, the first five tracks can be used for the L, C, R, SL and SR channels, the sub bass signal should be routed to the sixth track, track seven and eight can be used to record the stereo downmix.

We recommend to connect the five microphones with the optionally available multicore lead to exclude differences between the particular channels caused by varying tolerances of single wires.

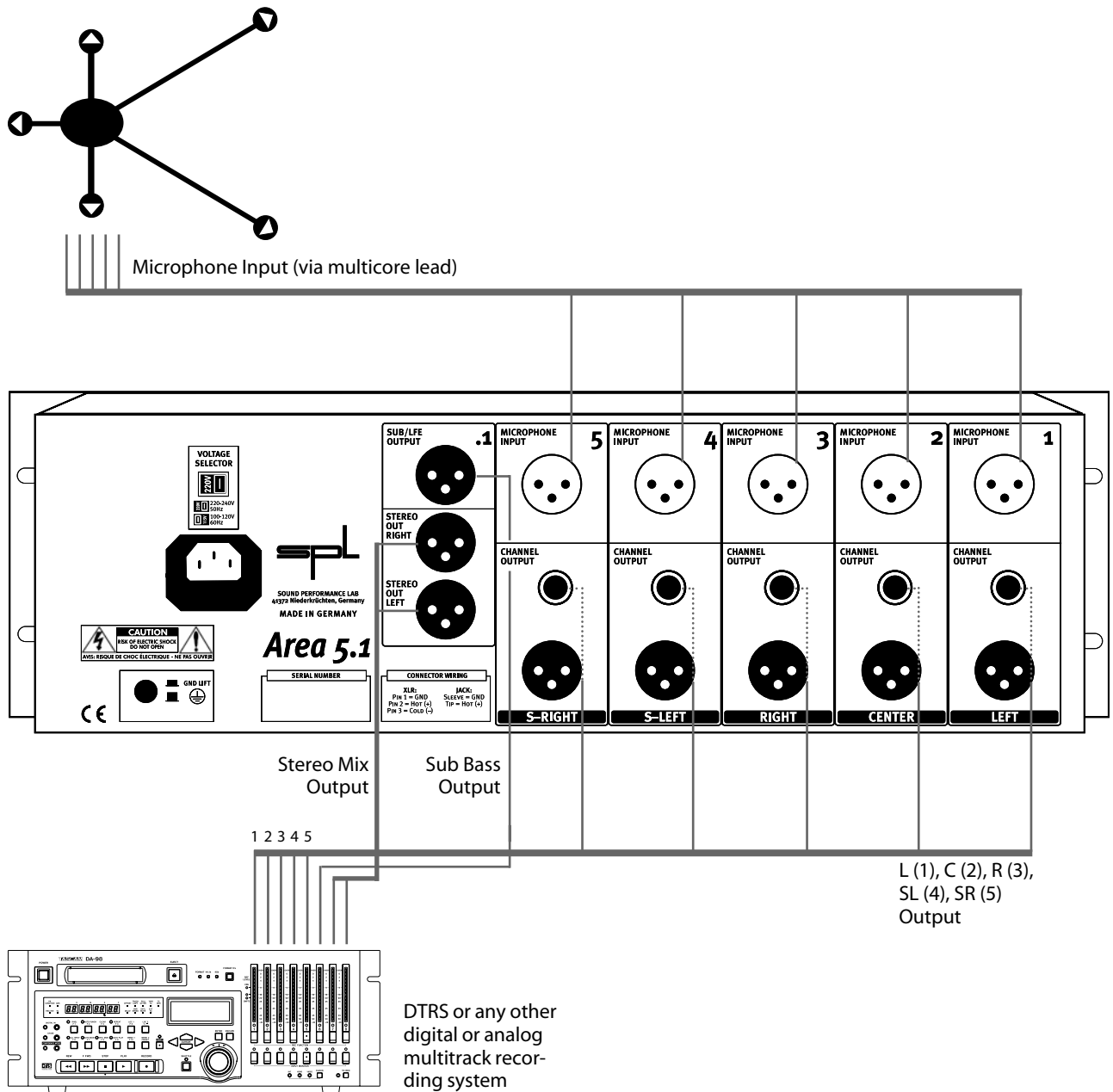

SPL Mic Array

The SPL Mic Array was designed to arrange any suitable microphones in the setup based on the ASM 5 design of SPL's Atmos 5.1 system. The outstanding quality of its 5.1 surround reproduction has been proven in many occasions. With large double membrane microphones in use, excellent tonal results are combined with minimum efforts. Basic advantages of the combination with the SPL Mic Array are:

- First proven standard setup to capture three-dimensional sound images in all recording situations
- Only one mic stand to mount the array
- Easy to move / fast and easy positioning
- Suited for all microphone types (matched mics recommended)
- First discrete 5.1 system for motion recordings

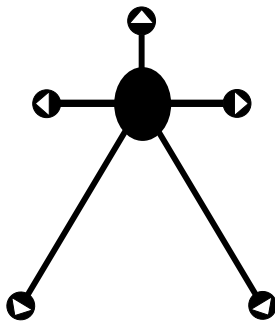

To get the most out of the Area 5.1 system it is essential to use appropriate microphones. Most important for best results is to use matched microphones at least for the L/R and SR/SL channel pairs, however we recommend to employ five matched microphones with large double membranes.

To start, choose cardioid microphone characteristics for all five microphones. The microphones should point in the directions shown in the graphic to the left. Many variations of this setup, depending on the microphones and recording situations, can be tested to find the best solution.

Operation *Preamplifier*

High precision gain preamplifiers

The Area 5.1 is equipped with five matched high precision microphone preamps to capture the sound sources in the most transparent, noiseless and uncolored way. The mic gain controls cover a range from 24 dB up to 60 dB. Lundahl microphone transformers optionally available.

The microphone preamps employ SPL's unique ServoDrive-Technology® which detects voltage differences (DC-offset) between the positive and negative paths of the amplifying stages. Any offset increases noise and distortion which compromises signal quality. ServoDrive minimizes DC-offsets to values between 0 mV and 2 mV. The signal contains less noise and distortion and improved tonal transparency.

Motorized master/slave mic gain controls

An important feature of the Area 5.1 are its motorized mic gain controls. A switch enables motorized control over all five microphone preamplifiers by just turning one control. This is important when readjustment of the preamplification becomes necessary while recording. Readjusting the preamplification manually is impossible since only 2 channels can be adjusted at once. The motorized mic gain controls also ensure not to influence the coherence of the room sound (phasing effects occur already at minimum differences).

Ch. 1-4 Lock

To *activate* the master mic gain control, *press* the Ch.1-4 lock button in the channel 5 section. Now the mic gain control of channel 5 is the master control for all five channels. The mic gain controls allow amplifications from 24 dB up to 60 dB.

Pad

The Pad switch (long life gold plated relays) attenuates the input signal by -25 dB, allowing high-level signals to be preamplified. This may apply to loud drum or brass recordings. Line-level signals (like keyboards or other preamplified signals) may be processed as well.

Rev

The phase reverse switch (long life gold plated relays) reverses the polarity of the microphone signal. If the switch is pressed the phase is rotated through 180°. Incorrect polarity leads to an unnatural tone and to drastic tonal changes, if the distance to the microphone is varied. We recommend that you check the polarity and correct it if necessary before commencing recording.

48 V

The 48 V phantom power button serves to supply condenser microphones which are equipped with in-built preamplifiers. A precise construction and disturbance free electrical supply are the main requirements for their trouble free operation. The voltage is maintained precisely at 48 V and delivers a maximum current of 14 mA, sufficient for all types of microphones.

WARNING: All microphones with balanced, ground free output (including tube microphones) can be operated with phantom power switched on. The following procedure is to be adhered to: Firstly connect the microphones to the Area 5.1, then switch on the phantom power – you can now commence work. When recording has been completed firstly switch off the phantom power then wait 30 seconds before disconnecting the microphone from the Area 5.1. This allows residual voltages to be discharged and improves operational safety. **Phantom powering is only used with condenser microphones. With any other type of microphone it is to be switched off! An unbalanced microphone is not to be used with phantom power switched on!**

Sub/LFE channel

In the Sub/LFE channel the Sub signal can be composited from any combination of L/R, C or SL/SR inputs. The gain control allows to adjust the Sub/LFE channel output level between -26 dB and +6 dB.

Area 5.1

Operation

Stereo downmix stages

Sub/LFE channel

To separate those frequencies that are not localisable, a 24 dB Butterworth low-pass filter can be activated at 130 Hz (Dolby AC 3). If the low-pass filter is not activated, the output can be fed to any other LFE processor to generate the Sub/LFE signal for other encodings such as DTS.

Stereo downmix stages

The Area 5.1 allows to record 5.1 and stereo signals in parallel. For each of the five channels a stereo downmix stage allows to control the particular level and panorama in the stereo image. Each channel is muted when the Mute switch is *not* pressed.

Dual concentric volume/pan controls

The inner ring of the dual concentric controls determines the output level for the concerning channel. The control range covers values from -65 dB to +12 dB.

The outer ring of the dual concentric controls allows to adjust the panorama of the channel's signal in the stereo image. The pan control is center detented.

Operation

Stereo output

Gain control

To determine the output gain of the stereo downmix use the gain control in the stereo output section. It covers values from -80 dB up to +6 dB. Two peak LEDs illuminate 6 dB before clipping for the left and right channel of the stereo signal.

Operation

Monitoring

Monitoring section

In the Monitor section a plug is installed on the front panel to connect any stereo headphone. A volume control serves to adjust the monitoring volume.

The L/R, SUB, SL/SR, C and Stereo buttons are used to select the channels to be monitored. This way, any channel or channel combination of the preamp output signal can be monitored.

Operation

Output PPM meter

Output PPM meter

The preamplifier output gain values for all 6 channels (L, C, R, SL, SR, Sub) are displayed on the PPM output meters. The PPM meter shows the peak levels and ranges from -48 dB up to +9 dB.

Power Supply

Built around a torroidal transformer, the power supply allows for a minimal electromagnetic field with no hum or mechanical noise. The power supply's output side is filtered by an RC circuit to extract noise and hums caused by your power service. 30.000µf capacitors smooth out the positive and negative half waves.

The phantom power is derived from a separate winding in the transformer, a precise current regulator delivers a clean phantom power of 48 volts. High quality 0.1%/6,81 kOhm resistors ensure the pristine quality of the phantom power supply.

The supply voltage can be set to 230 V/50 Hz or 115 V/60 Hz. Check your country's power requirements for the appropriate setting. An AC power cord is included to feed the IEC-spec, 3-prong connector. Transformer, AC cord and IEC-receptacle are VDE, UL and CSA approved.

Chassis ground and AC ground can be physically disconnected by the "Ground Lift" switch (GND LIFT). This helps to eliminate hums.

Frequency Response: 10 Hz-50 kHz
(50 kHz = -3 dB)

Common Mode Rejection: 1 kHz: -80 dB / 10 kHz: >-60 dB
(@ -20 dBu)

THD & N:	Amplification:	A weighted:
	20 dB	-97,1 dBu
	40 dB	-91,1 dBu
	60 dB	-71,0 dBu

Dynamic Response: 119 dB

Max. Output Level XLR / Jack: +20 dBu

Output Impedance: <75 Ohm

Housing: Standard EIA 19"/3U
... 482 x 132 x 237 mm

Weight: 7.3 kg

Subject to change without notice.

Specifications

Warranty

SPL electronics GmbH (hereafter called SPL) products are warranted only in the country where purchased, through the authorized SPL distributor in that country, against defects in material or workmanship. The specific period of this limited warranty shall be that which is described to the original retail purchaser by the authorized SPL dealer or distributor at the time of purchase.

SPL does not, however, warrant its products against any and all defects:

1) arising out of materials or workmanship not provided or furnished by SPL, or 2) resulting from abnormal use of the product or use in violation of instructions, or 3) in products repaired or serviced by other than authorized SPL repair facilities, or 4) in products with removed or defaced serial numbers, or 5) in components or parts or products expressly warranted by another manufacturer.

SPL agrees, through the applicable authorized distributor, to repair or replace defects covered by this limited warranty with parts or products of original or improved design, at its option in each respect, if the defective product is shipped prior to the end of the warranty period to the designated authorized SPL warranty repair facility in the country where purchased, or to the SPL factory in Germany, in the original packaging or a replacement supplied by SPL, with all transportation costs and full insurance paid each way by the purchaser or owner.

All remedies and the measure of damages are limited to the above services. It is possible that economic loss or injury to person or property may result from the failure of the product; however, even if SPL has been advised of this possibility, this limited warranty does not cover any such consequential or incidental damages. Some states or countries do not allow the limitations or exclusion of incidental or consequential damages, so the above limitation may not apply to you.

Any and all warranties, express or implied, arising by law, course of dealing, course of performance, usage of trade, or otherwise, including but not limited to implied warranties of merchantability and fitness for particular, are limited to a period of 1 (one) year from either the date of manufacture. Some states or countries do not allow limitations on how long an implied warranty lasts, so the above limitations may not apply to you.

This limited warranty gives you specific legal rights, and you may also have other rights which vary from state to state, country to country.

SPL electronics GmbH
41372 Niederkruechten, Germany

.....

.....

.....

.....

.....

.....

.....

.....

.....

.....

.....

.....

.....

.....

.....

.....

.....

.....

.....

.....

.....

.....

.....

.....

.....

.....

.....

.....

.....

.....

.....

.....

.....

.....

.....

.....

.....

.....

.....



Sound Performance Lab

Sohlweg 55

D-41372 Niederkrüchten, Germany

Phone: +49 · 2163 · 98340, Fax: +49 · 2163 · 983420

Website: www.soundperformancelab.com

Mail to: info@soundperformancelab.com

„NEVER let it be said that SPL is a dull company.“

Dave Foister, Studio Sound

