

### Application

Model SMDR-501 is a round smoke damper with extremely low leakage. The SMDR-501 has been qualified to 3,000 fpm (15.2 m/s) and 4 in. wg (1.0 kPa) for operational closure in emergency smoke control situations, for use in HVAC system applications.

### Ratings

**Leakage:** Class I  
**Pressure:** 4 in. wg (1.0 kPa) - differential pressure  
**Maximum Velocity:** 3000 fpm (15.2 m/s)  
**Temperature:** 350°F (177°C) depending on the actuator.

### Standard Construction

**Frame/sleeve:** 20 ga. (1mm) galvanized steel round integral sleeve  
**Blades:** Double skin galvanized steel (14 ga. [2mm] equivalent) round style blades  
**Seals:** Silicone rubber.  
**Axles:** 1/2 in. (13mm) dia. plated steel.  
**Bearings:** Oil impregnated stainless steel

### Size Limitations:

**Minimum Size:** 6 in. diameter (152mm)  
**Maximum Size:** 24 in. diameter (610mm)

### Optional Features:

- Electric or pneumatic actuators to accomplish smoke management and system functions.
- Open/Close Indicator (OCI) for remote indication of blade position.
- 14 ga. (2mm) or 16 ga. (1.5mm) frame/sleeve

### Specifications

True Round Smoke Dampers meeting the following specifications shall be furnished and installed where shown on plans and/or as described in schedules. Dampers shall meet the requirements of the latest edition of NFPA 92A, 92B, 101 & 105.

Dampers shall be tested, rated and labeled in accordance with the latest edition of UL Standards 555S. Dampers shall be UL labeled for use in dynamic systems. The damper shall have a dynamic closure airflow rating equal to or greater than the airflow at the damper's installed location and a dynamic closure pressure rating of 4 in. wg (1kPa).

Dampers shall have a UL 555S leakage rating of Class I and a temperature rating of 250° F (121°C) minimum. Dampers shall have a UL555S operational airflow rating equal to or greater than the airflow at its installed location and an operational pressure rating of 4 in. wg (1 kPa). Damper actuators shall be factory mounted and qualified for use with the damper in accordance with UL555S.

Model SMDR-501 meets the requirements for smoke dampers established by:

**National Fire Protection Association**  
NFPA Standards 92A, 92B, 101 & 105  
**IBC International Building Codes**  
**New York City** (MEA listing #260-91-M)  
**California State Fire Marshall**  
Listing #: 2330-0981:104

**"UL CLASSIFIED (see complete marking on product)"**  
**"UL CLASSIFIED to Canadian safety standards (see complete marking on product)"**  
Standard 555S (Listing #R13317)

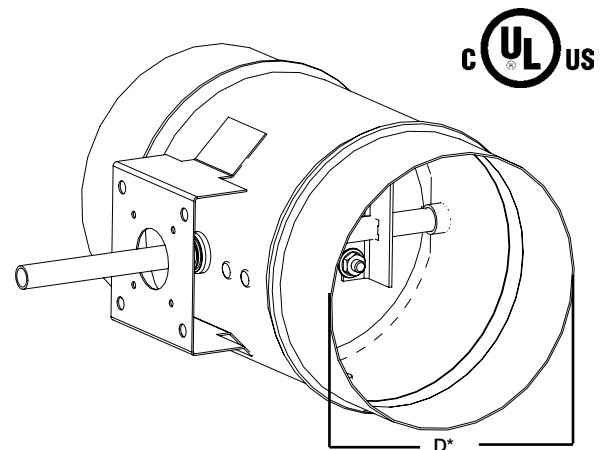

\* D dimension furnished approximately 1/8 in. (3mm) undersize.

Installation instructions available at [www.greenheck.com](http://www.greenheck.com).

Damper actuators shall be (specified select one of the following) electric type for 120 (or 24) volt operation or pneumatic type for 25 psi minimum operation (30 psi maximum). Manufacturer's submittal data shall indicate actuator space requirements around the damper.

All UL555S operational ratings and leakage ratings shall be qualified for airflow and pressure in either direction through the damper. UL ratings shall allow for mounting damper vertically or horizontally.

The Damper Manufacturer's submittal data shall certify all air performance pressure drop data is licensed in accordance with the AMCA certified ratings program for test figures 5.2, 5.3, and 5.5. Damper air performance data shall be developed in accordance with the latest edition of AMCA Standard 500-D.

Basis of design is Greenheck's model SMDR-501.