

DS90C3202

3.3V 8 MHz to 135 MHz Dual FPD-Link Receiver

General Description

The DS90C3202 is a 3.3V single/dual FPD-Link 10-bit color receiver is designed to be used in Liquid Crystal Display TVs, LCD Monitors, Digital TVs, and Plasma Display Panel TVs. The DS90C3202 is designed to interface between the digital video processor and the display device using the low-power, low-EMI LVDS (Low Voltage Differential Signaling) interface. The DS90C3202 converts up to ten LVDS data streams back into 70 bits of parallel LVCMOS/LVTTL data. The receiver can be programmed with rising edge or falling edge clock. Optional two-wire serial programming allows fine tuning in development and production environments. With an input clock at 135 MHz, the maximum transmission rate of each LVDS line is 945 Mbps, for an aggregate throughput rate of 9.45 Gbps (945 Mbytes/s). This allows the dual 10-bit LVDS Receiver to support resolutions up to HDTV.

Features

- Up to 9.45 Gbit/s data throughput
- 8 MHz to 135 MHz input clock support
- Supports up to QXGA panel resolutions
- Supports HDTV panel resolutions and frame rates up to 1920 x 1080p
- LVDS 30-bit, 24-bit or 18-bit color data inputs
- Supports single pixel and dual pixel interfaces
- Supports spread spectrum clocking
- Two-wire serial communication interface
- Programmable clock edge and control strobe select
- Power down mode
- +3.3V supply voltage
- 128-pin TQFP Package
- Compliant to TIA/EIA-644-A-2001 LVDS Standard

Block Diagram

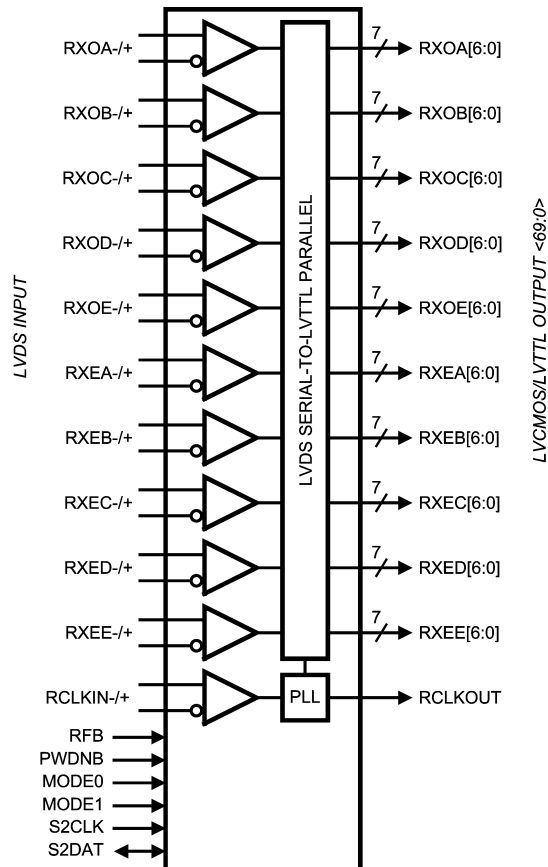

FIGURE 1. Receiver Block Diagram

20147101

Typical Application Diagram

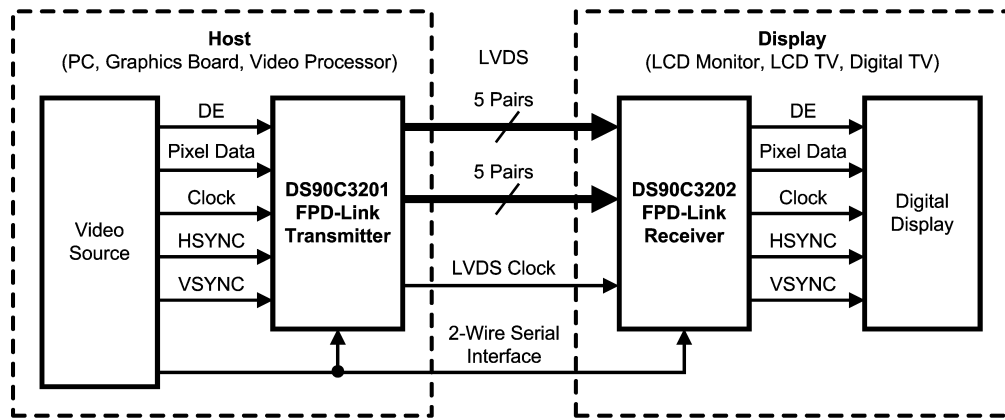

FIGURE 2. LCD Panel Application Diagram

20147102

Functional Description

The DS90C3201 and DS90C3202 are a dual 10-bit color Transmitter and Receiver FPD-Link chipset designed to transmit data at clocks speeds from 8 to 135 MHz. DS90C3201 and DS90C3202 are designed to interface between the digital video processor and the display using a LVDS interface. The DS90C3201 transmitter serializes 2 channels of video data (10-bit each for RGB for each channel, totaling 60 bits) and control signals (HSYNC, VSYNC, DE and two user-defined signals) along with clock signal to 10 channels of LVDS signals and transmits them. The DS90C3202 receiver converts 10 channels of LVDS signals into parallel signals and outputs 2 channels of video data (10-bit each for RGB for each channel, totaling 60 bits) and control signals (HSYNC, VSYNC, DE and two user-defined signals) along with clock signal. The dual high speed LVDS channels supports single pixel in-single pixel out and dual pixel in-dual pixel out transmission modes. The FPD-Link chipset is suitable for a variety of display applications including LCD Monitors, LCD TV, Digital TV, and DLP TV, and Plasma Display Panels.

Using a true 10-bit color depth system, the 30-bit RGB color produces over 1.07 billion colors to represent High Definition (HD) displays in their most natural color, surpassing the maximum 16.7 million colors achieved by 6/8-bit color conventionally used for large-scale LCD televisions and LCD monitors.

LVDS RECEIVER

The LVDS Receiver receives input RGB video data and control signal timing.

SELECTABLE OUTPUT DATA STROBE

The Receiver output data edge strobe can be latched on the rising or falling edges of clock signal. The dedicated RFB pin is used to program output strobe select on the rising edge of RCLK or the falling edge of RCLK.

2-WIRE SERIAL COMMUNICATION INTERFACE

Optional Two-Wire serial interface programming allows fine tuning in development and production environments. The Two-Wire serial interface provides several capabilities to reduce EMI and to customize output timing. These capabilities are selectable/programmable via Two-Wire serial interface: Programmable Skew Rates, Progress Turn On Function, Input/Output Channel Control.

PROGRAMMABLE SKEW RATES

Programmable edge rates allow the LVCMOS/LVTTL Data and Clock outputs to be adjusted for better impedance matching for noise and EMI reduction. The individual output drive control registers for Rx data out and Rx clock out are programmable via Two-Wire serial interface.

PROGRESS TURN ON FUNCTION

Progress Turn On (PTO) function aligns the two output channels of LVCMOS/LVTTL in either a non-skew data format (simultaneous switching) or a skewed data format (staggered). The skewed format delays the selected channel data and staggers the outputs. This reduces the number of outputs switching simultaneously, which lowers EMI radiation and minimizes ground bounce. Feature is controlled via Two-Wire serial interface.

INPUT/OUTPUT CHANNEL CONTROL

Full independent control for input/output channels can be disabled to minimize power supply line noise and overall power dissipation. Feature is configured via Two-Wire serial interface

Absolute Maximum Ratings (Note 1)

If Military/Aerospace specified devices are required, please contact the National Semiconductor Sales Office/Distributors for availability and specifications.

Supply Voltage (V_{DD})	-0.3V to +4V
LVC MOS/LVTTL Input Voltage	-0.3V to ($V_{DD} + 0.3V$)
LVC MOS/LVTTL Output Voltage	-0.3V to ($V_{DD} + 0.3V$)
LVDS Receiver Input Voltage	-0.3V to ($V_{DD} + 0.3V$)
Junction Temperature	+150°C
Storage Temperature	-65°C to +150°C
Lead Temperature (Soldering, 10 sec.)	+260°C
Maximum Package Power Dissipation Capacity @ 25°C	
128 TQFP Package:	1.4W

Package Derating: 25.6mW/°C above +25°C

ESD Rating:

(HBM, 1.5k Ω , 100pF)

> 2 kV

(EIAJ, 0 Ω , 200pF)

> 200 V

Recommended Operating Conditions

	Min	Nom	Max	Units
Supply Voltage (V_{DD})	3.15	3.3	3.6	V
Operating Free Air Temperature (T_A)	0	+25	+70	°C
Supply Noise Voltage (V_{P-P})			± 100	mV _{P-P}
Receiver Input Range	0		V_{DD}	V
Input Clock Frequency (f)	8		135	MHz

Electrical Characteristics

Over recommended operating supply and temperature ranges unless otherwise specified.

Symbol	Parameter	Conditions	Min	Typ	Max	Units
CMOS/TTL DC SPECIFICATIONS (Rx outputs, control inputs and outputs)						
V_{IH}	High Level Input Voltage		2.0		V_{DD}	V
V_{IL}	Low Level Input Voltage		0		0.8	V
V_{OH}	High Level Output Voltage	Rx clock out	2.4			V
		Rx data out				
V_{OL}	Low Level Output Voltage	Rx clock out			0.4	V
		Rx data out				
V_{CL}	Input Clamp Voltage	$I_{CL} = -18$ mA		-0.8	-1.5	V
I_{IN}	Input Current	$V_{IN} = V_{DD}$			+10	μ A
		$V_{IN} = 0V$	-10			μ A
I_{OS}	Output Short Circuit Current	$V_{OUT} = 0V$			-120	mA
LVDS RECEIVER DC SPECIFICATIONS						
V_{TH}	Differential Input High Threshold	$V_{CM} = +1.2V$			+100	mV
V_{TL}	Differential Input Low Threshold		-100			mV
V_{IN}	Input Voltage Range (Single-ended)		0		V_{DD}	V
$ V_{ID} $	Differential Input Voltage		0.200		0.600	V
V_{CM}	Differential Common Mode Voltage		0.2	1.2	$V_{DD}-0.1$	V
I_{IN}	Input Current	$V_{IN} = +2.4V, V_{DD} = 3.6V$			± 10	μ A
		$V_{IN} = 0V, V_{DD} = 3.6V$			± 10	μ A

Electrical Characteristics (Continued)

Over recommended operating supply and temperature ranges unless otherwise specified.

Symbol	Parameter	Conditions	Min	Typ	Max	Units	
RECEIVER SUPPLY CURRENT							
ICCRW	Receiver Supply Current Worst Case (Figures 2, 4)	$C_L = 8$ pF, Worst Case Pattern Default Register Settings	$f = 8$ MHz		65	130	mA
			$f = 135$ MHz		375	550	mA
ICCRG	Receiver Supply Current Incremental Test Pattern (Figures 3, 4)	$C_L = 8$ pF, Worst Case Pattern Default Register Settings	$f = 8$ MHz		55	120	mA
			$f = 135$ MHz		245	400	mA
ICCRZ	Receiver Supply Current Power Down	PDWNB = Low Receiver Outputs stay low during Powerdown mode. Default Register Settings			2	mA	

Note 1: "Absolute Maximum Ratings" are those values beyond which the safety of the device cannot be guaranteed. They are not meant to imply that the device should be operated at these limits. The tables of "Electrical Characteristics" specify conditions for device operation.

Note 2: Typical values are given for $V_{DD} = 3.3V$ and $T_A = +25^\circ C$.

Note 3: Current into device pins is defined as positive. Current out of device pins is defined as negative. Voltages are referenced to ground unless otherwise specified.

Note 4: The worst case test pattern produces a maximum toggling of digital circuits, LVDS I/O and LVCMOS/LVTTL I/O.

Note 5: The incremental test pattern tests device power consumption for a "typical" LCD display pattern.

Note 6: Figures 2, 3 show a falling edge data strobe (RCLK OUT).

Note 7: Figure 8 show a rising edge data strobe (RCLK OUT).

Receiver Switching Characteristics

Over recommended operating supply and temperature ranges unless otherwise specified.

Symbol	Parameter	Condition/ Reference	Min	Typ	Max	Units
CLHT	LVCMOS/LVTTL Low-to-High Transition Time, $C_L = 8\text{pF}$, (Figure 5) (Note 8) Register addr 28d/1ch, bit [2] (RCLK)=0b (Default), bit [1] (RXE) =0b (Default), bit [0] (RXO) =0b (Default)	Rx clock out		1.45	2.10	ns
		Rx data out		2.40	3.50	ns
CHLT	LVCMOS/LVTTL High-to-Low Transition Time, $C_L = 8\text{pF}$, (Figure 5) (Note 8) Register addr 28d/1ch, bit [2] (RCLK)=0b (Default), bit [1] (RXE) =0b (Default), bit [0] (RXO) =0b (Default)	Rx clock out		1.35	2.20	ns
		Rx data out		2.40	3.60	ns
CLHT Programmable adjustment	LVCMOS/LVTTL Low-to-High Transition Time, $C_L = 8\text{pF}$, (Figure 5) (Note 8) Register addr 28d/1ch, bit [2] (RCLK)=1b (Default), bit [1] (RXE) =1b (Default), bit [0] (RXO) =1b (Default)	Rx clock out		2.45		ns
		Rx data out		3.40		ns
CHLT Programmable adjustment	LVCMOS/LVTTL High-to-Low Transition Time, $C_L = 8\text{pF}$, (Figure 5) (Note 8) Register addr 28d/1ch, bit [2] (RCLK)=0b (Default), bit [1] (RXE) =0b (Default), bit [0] (RXO) =0b (Default)	Rx clock out		2.35		ns
		Rx data out		3.40		ns
RCOP	RCLK OUT Period (Figures 11, 12) (Note 8)	8–135 MHz	7.4	T	125	ns
RCOH	RCLK OUT High Time (Figures 11, 12)	Rx clock out	0.4T	0.5T	0.6T	ns
RCOL	RCLK OUT Low Time (Figures 11, 12)	Rx clock out	0.4T	0.5T	0.6T	ns
RSRC	RxOUT Setup to RCLK OUT (Figures 11, 12) (Notes 8, 9) Register addr 29d/1dh [2:1]= 00b (Default)		2.60	0.5T		ns
RHRC	RxOUT Hold to RCLK OUT (Figures 11, 12) (Notes 8, 9) Register addr 29d/1dh [2:1]= 00b (Default)		3.60	0.5T		ns
RSRC/RHRC Programmable Adjustment	Register addr 29d/1dh [2:1] = 01b, (Figures 13, 14) (Notes 2, 10) RSRC increased from default by 1UI RHRC decreased from default by 1UI			+1UI / -1UI		ns
	Register addr 29d/1dh [2:1] = 10b, (Figures 13, 14) (Notes 2, 10) RSRC decreased from default by 1UI RHRC increased from default by 1UI			-1UI / +1UI		ns
	Register addr 29d/1dh [2:1] = 11b, (Figures 13, 14) (Notes 2, 10) RSRC increased from default by 2UI RHRC decreased from default by 2UI			+2UI / -2UI		ns
RPLLS	Receiver Phase Lock Loop Set (Figure 6)				10	ms
RPDD	Receiver Powerdown Delay (Figure 7)				100	ns
RPDL	Receiver Propagation Delay — Latency (Figure 8)				4*RCLK	ns
RITOL	Receiver Input Tolerance (Figures 10, 16) (Notes 8, 10)	$V_{CM} = 1.25\text{V}$, $V_{ID} = 350\text{mV}$			0.25	UI

Note 8: Specification is guaranteed by characterization.

Note 9: A Clock Unit Symbol (T) is defined as 1/ (Line rate of RCLK). E.g. For Line rate of RCLK at 85MHz, 1 T = 11.76ns

Note 10: A Unit Interval (UI) is defined as 1/7th of an ideal clock period (RCLK/7). E.g. For an 11.76ns clock period (85MHz), 1 UI = 1.68ns

Two-Wire Serial Communication Interface

Over recommended operating supply and temperature ranges unless otherwise specified.

Symbol	Parameter	Conditions	Min	Typ	Max	Units
f_{sc}	S2CLK Clock Frequency				400	kHz
SC:LOW	Clock Low Period	$R_p = 4.7K\Omega, C_L = 50pF$	1.5			us
SC:HIGH	Clock High Period	$R_p = 4.7K\Omega, C_L = 50pF$	0.6			us
SCD:TR	S2CLK and S2DAT Rise Time	$R_p = 4.7K\Omega, C_L = 50pF$			0.3	us
SCD:TF	S2CLK and S2DAT Fall Time	$R_p = 4.7K\Omega, C_L = 50pF$			0.3	us
SU:STA	Start Condition Setup Time	$R_p = 4.7K\Omega, C_L = 50pF$	0.6			us
HD:STA	Start Condition Hold Time	$R_p = 4.7K\Omega, C_L = 50pF$	0.6			us
HD:STO	Stop Condition Hold Time	$R_p = 4.7K\Omega, C_L = 50pF$	0.6			us
SC:SD	Clock Falling Edge to Data	$R_p = 4.7K\Omega, C_L = 50pF$	0			us
SD:SC	Data to Clock Rising Edge	$R_p = 4.7K\Omega, C_L = 50pF$	0.1			us
SCL:SD	S2CLK Low to S2DAT Data Valid	$R_p = 4.7K\Omega, C_L = 50pF$	0.1		0.9	us
BUF	Bus Free Time	$R_p = 4.7K\Omega, C_L = 50pF$	13			us

AC Timing Diagrams

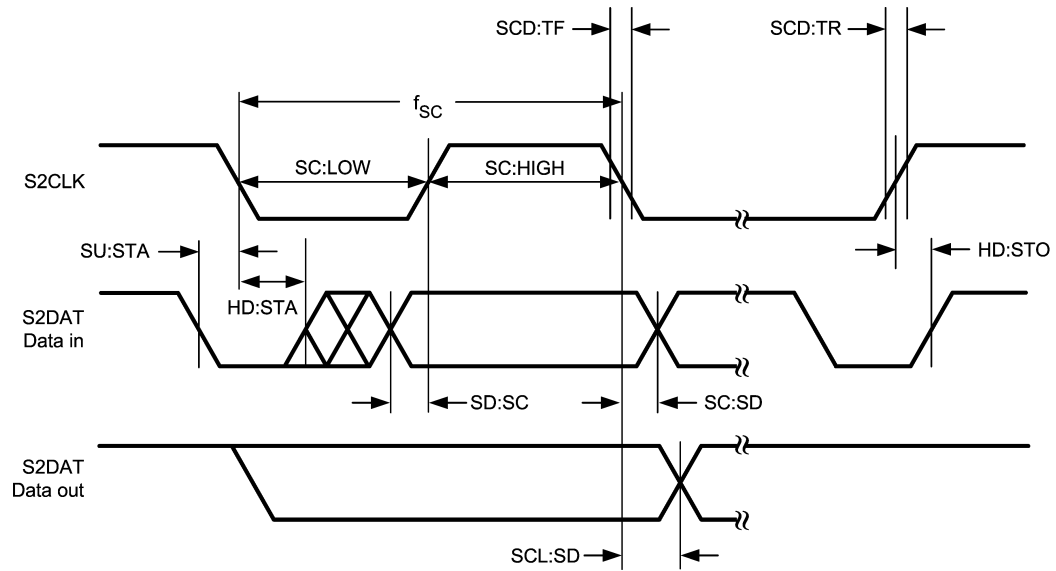

20147122

FIGURE 1. Two-Wire Serial Communication Interface Timing Diagram

AC Timing Diagrams (Continued)

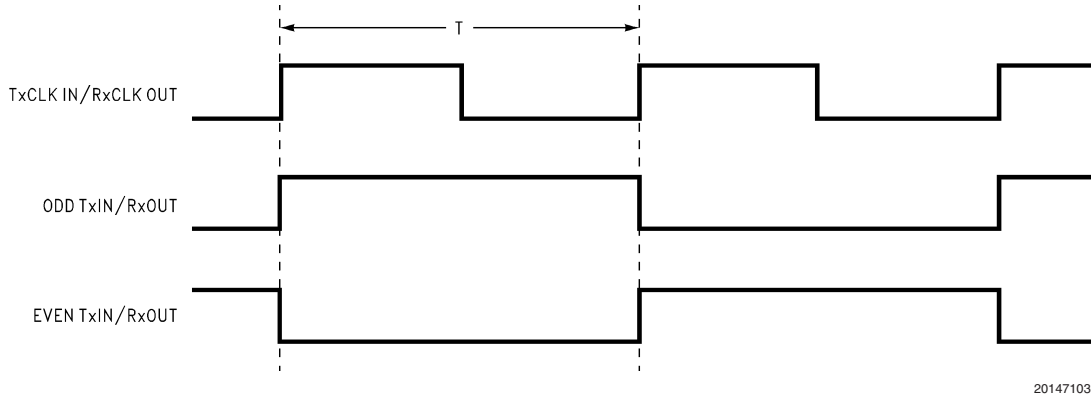

20147103

FIGURE 2. "Worst Case" Test Pattern

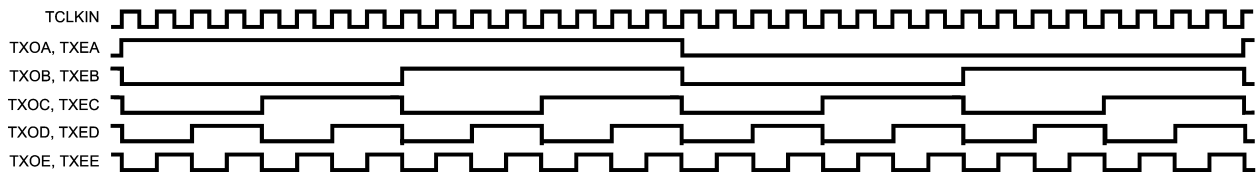

20147104

FIGURE 3. Incremental Test Pattern

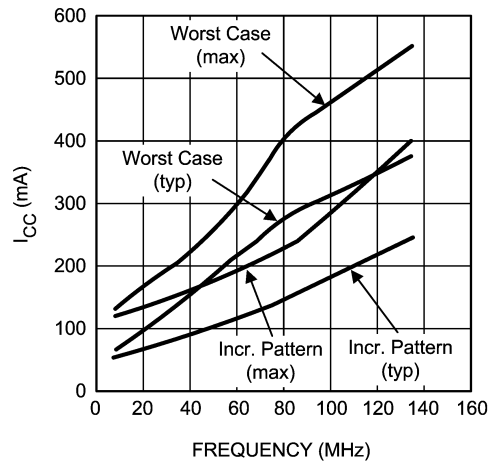

20147105

FIGURE 4. Typical and Max ICC with Worst Case and Incremental Pattern

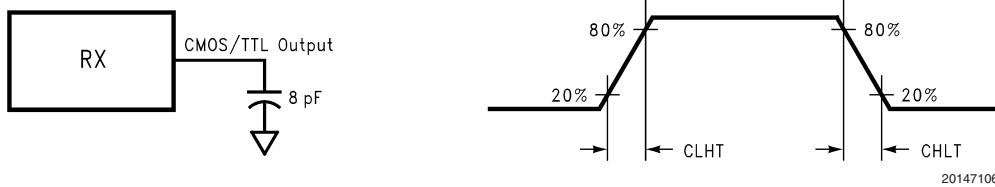

20147106

FIGURE 5. LVC MOS/LVTTL Output Load and Transition Times

AC Timing Diagrams (Continued)

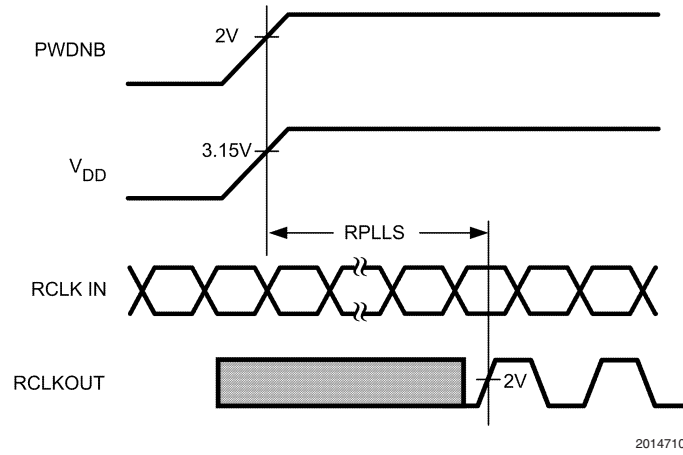

20147107

FIGURE 6. Receiver Phase Lock Loop Wake-up Time

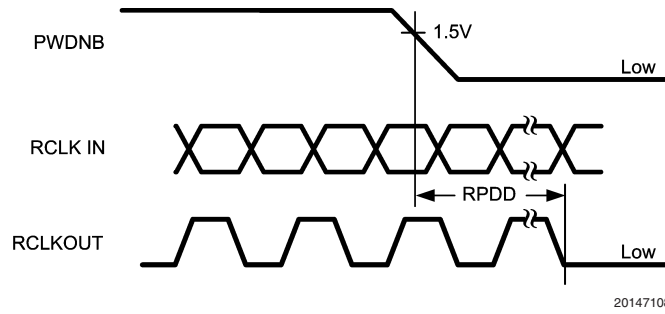

20147108

FIGURE 7. Powerdown Delay

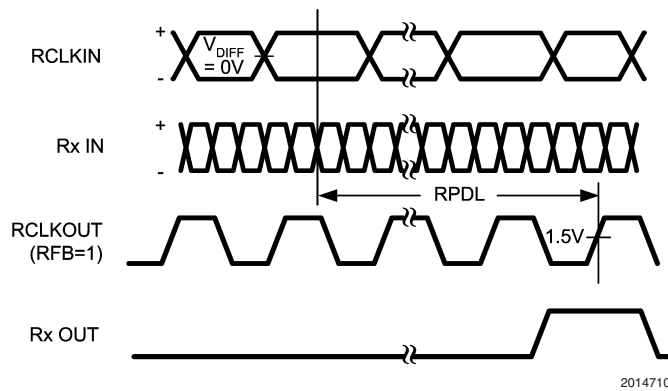

20147109

FIGURE 8. Receiver Propagation Delay

AC Timing Diagrams (Continued)

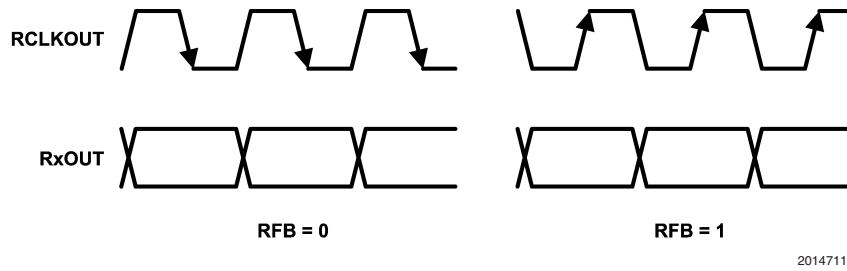
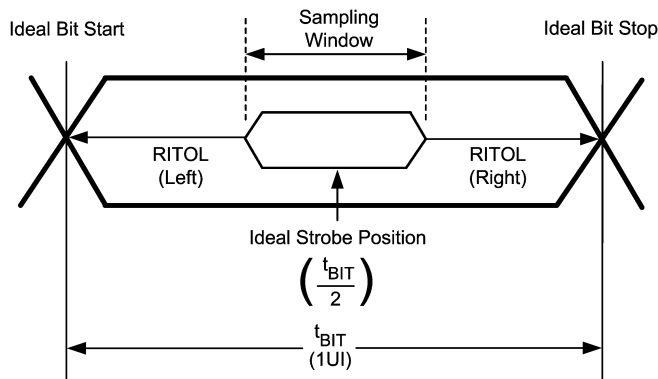

FIGURE 9. RFB: LVTTTL Level Programmable Strobe Select



RITOL ≥ Cable Skew (type, length) + Source Clock Jitter (cycle to cycle) (Note 11) + ISI (Inter-symbol interference) (Note 12)
 Cable Skew—typically 10 ps–40 ps per foot, media dependent
 Please see National's AN-1217 for more details.
Note 11: Cycle-to-cycle jitter is less than 100 ps (worse case estimate).
Note 12: ISI is dependent on interconnect length; may be zero.

FIGURE 10. Receiver Input Tolerance and Sampling Window

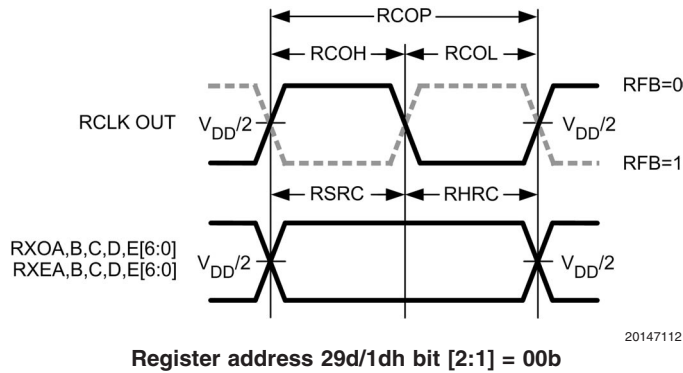

FIGURE 11. Receiver RSRC and RHRC Output Setup/Hold Time — PTO Disabled

AC Timing Diagrams (Continued)

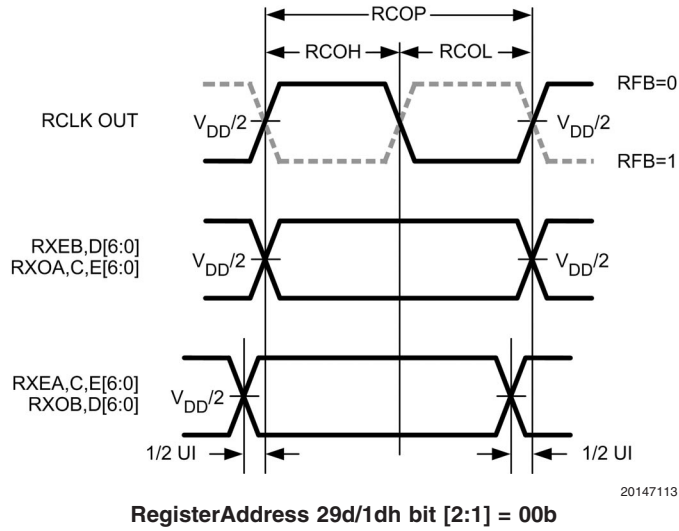

FIGURE 12. Receiver RSRC and RHRC Output Setup/Hold Time — PTO Enabled

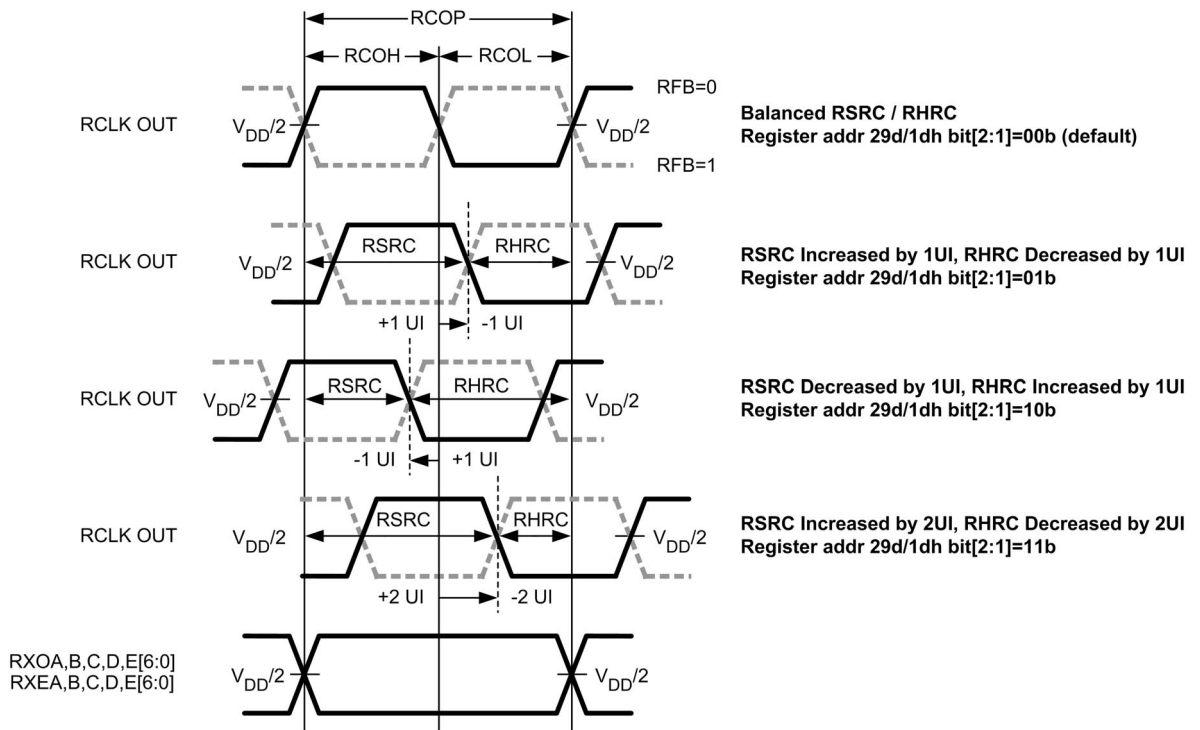
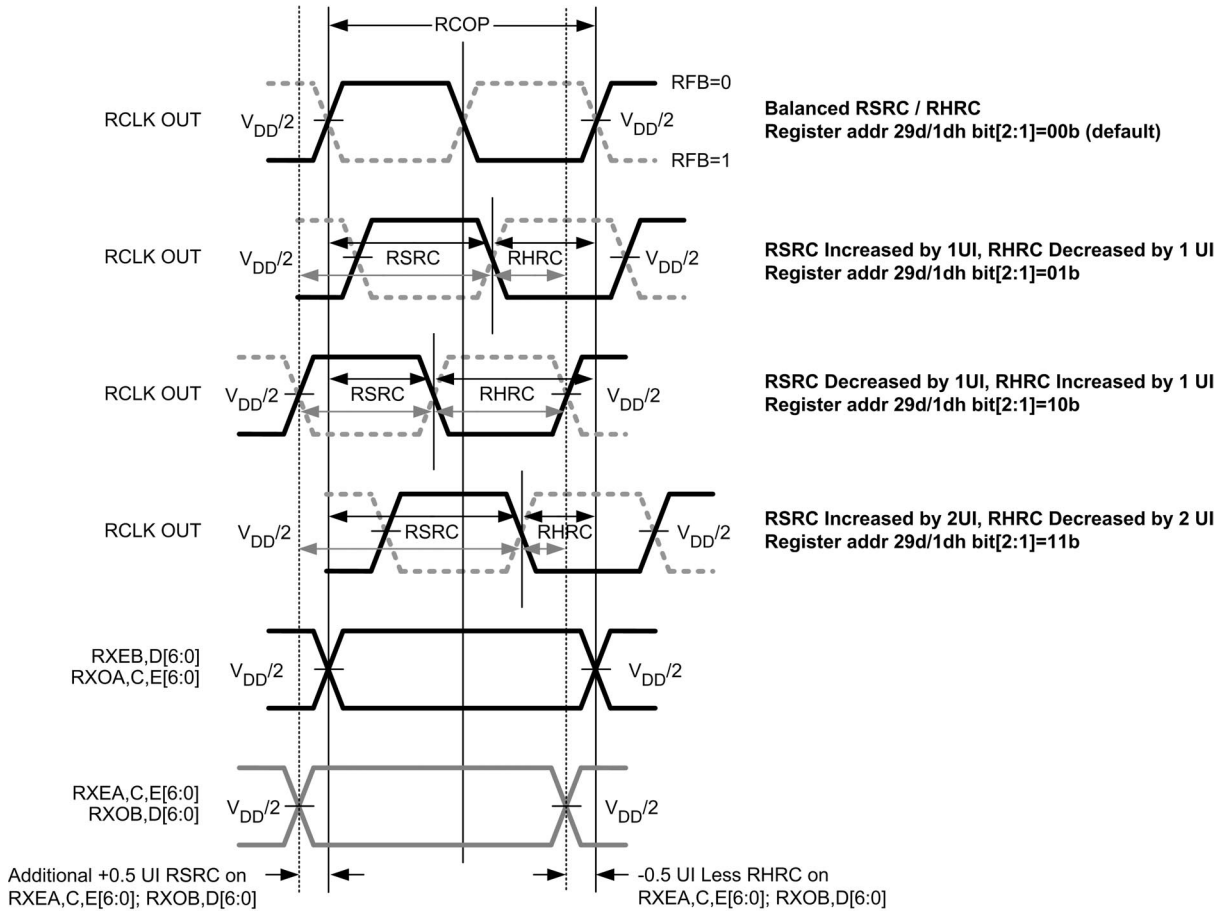

FIGURE 13. Receiver RSRC and RHRC Output Setup/Hold Time Adjustment — PTO Disabled

AC Timing Diagrams (Continued)



20147115

FIGURE 14. Receiver RSRC and RHRC Output Setup/Hold Time Adjustment — PTO Enabled

AC Timing Diagrams (Continued)

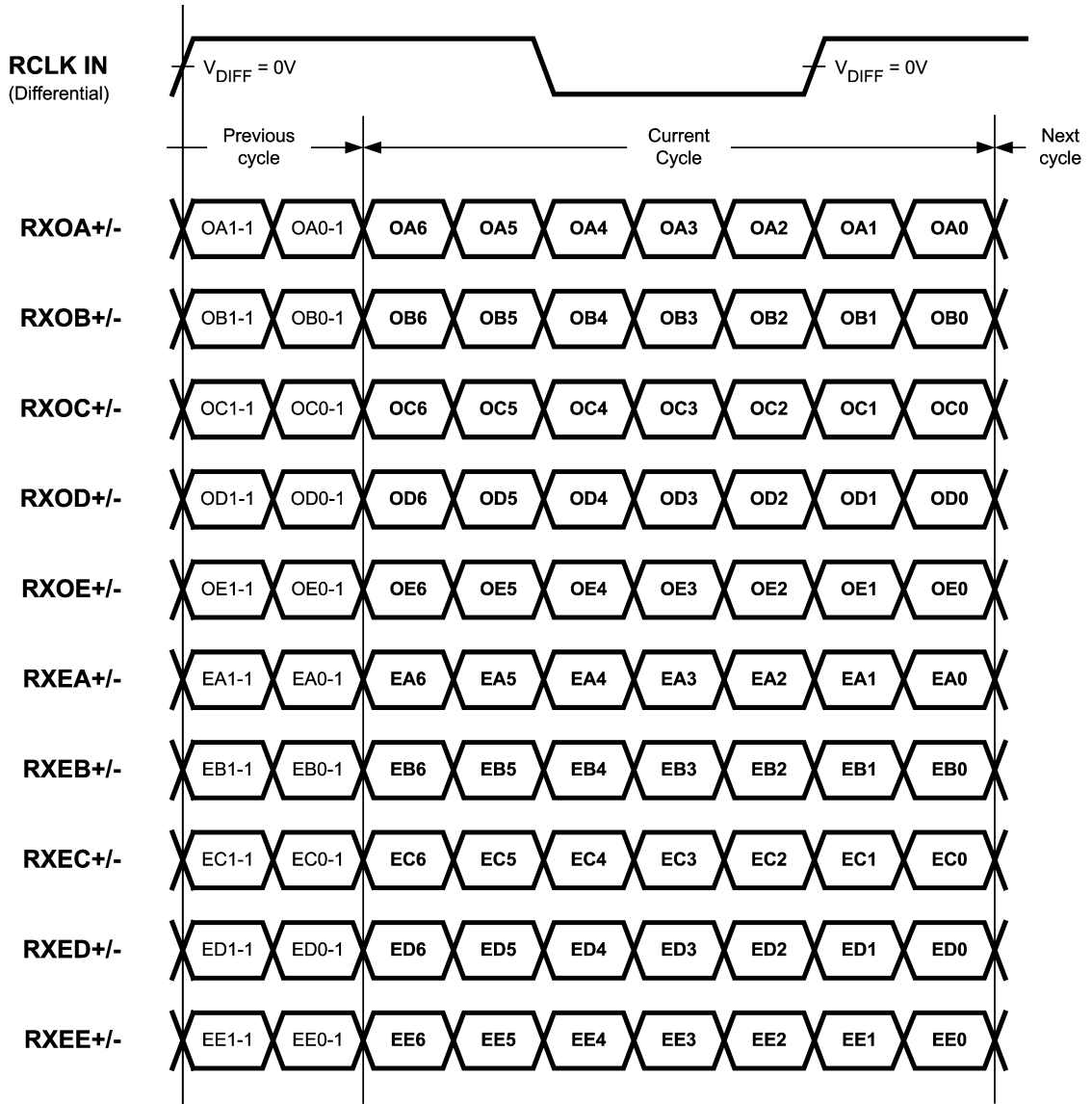

20147116

FIGURE 15. LVDS Input Mapping

AC Timing Diagrams (Continued)

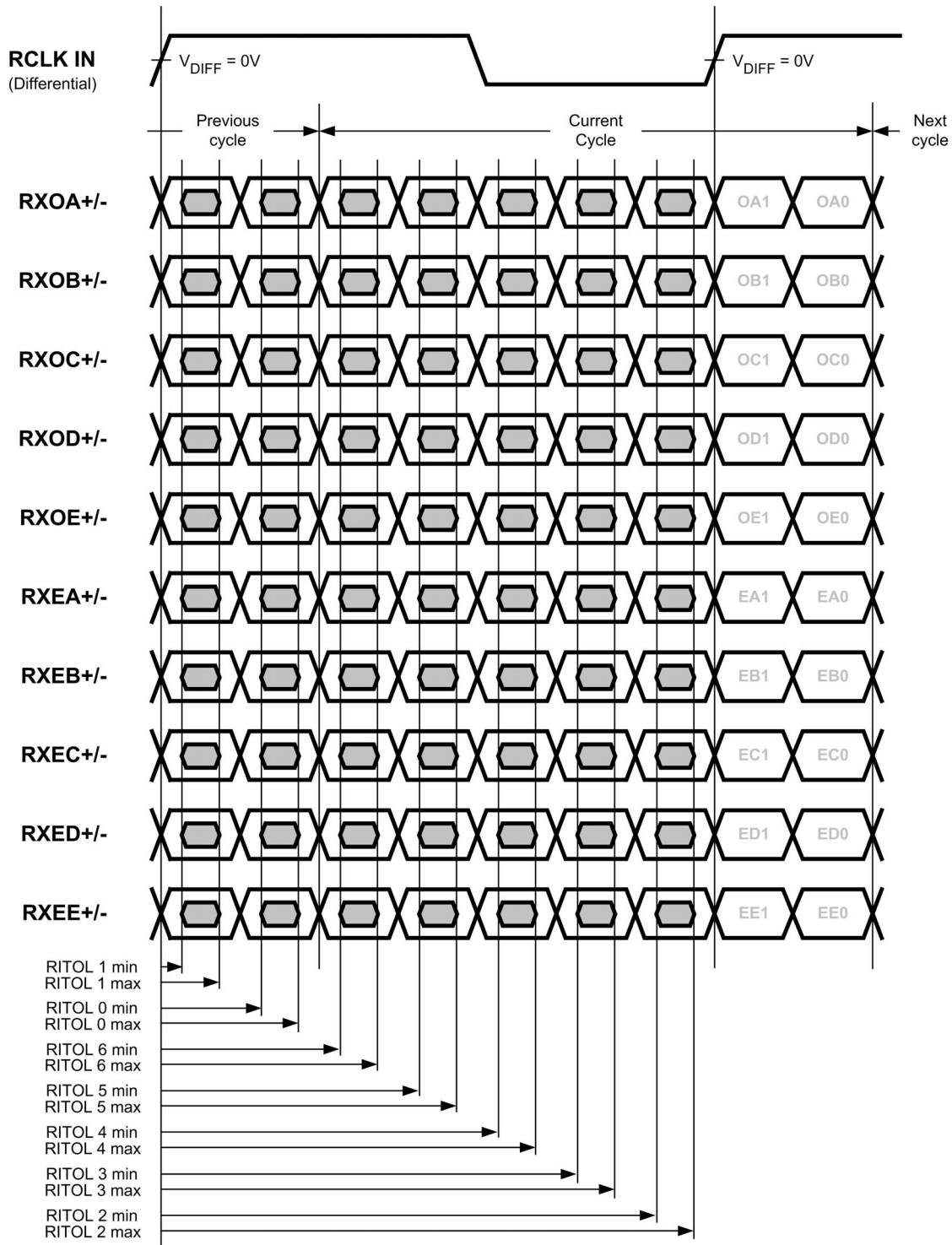

20147117

FIGURE 16. Receiver RITOL Min and Max

Pin Diagram

DS90C3202 Receiver

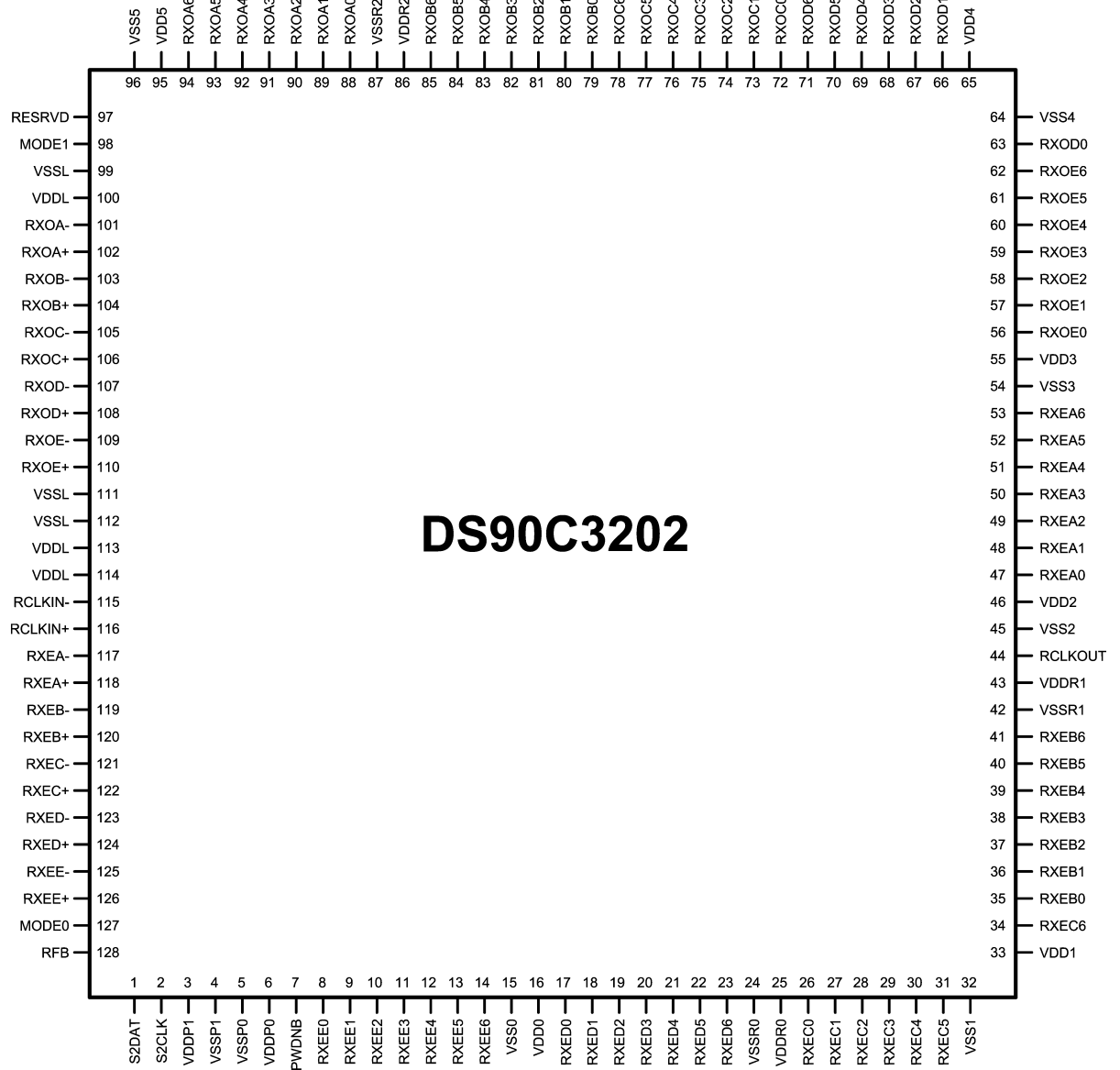

20147118

DS90C3202 Pin Descriptions

Pin No.	Pin Name	I/O	Pin Type	Description
1	S2DAT	I/OP	Digital	Two-wire Serial Interface – Data
2	S2CLK	I/P	Digital	Two-wire Serial Interface – Clock
3	VDDP1	VDD	PLL	Power supply for PLL circuitry
4	VSSP1	GND	PLL	Ground pin for PLL circuitry
5	VSSP0	GND	PLL	Ground pin for PLL circuitry
6	VDDP0	VDD	PLL	Power supply for PLL circuitry
7	PWDNB	I/P	LVTTL I/P (pulldown)	Powerdown Bar (Active LOW) 0 = DEVICE DISABLED 1 = DEVICE ENABLED
8	RXEE0	O/P	LVTTL O/P	LVTTL level data output
9	RXEE1	O/P	LVTTL O/P	LVTTL level data output
10	RXEE2	O/P	LVTTL O/P	LVTTL level data output
11	RXEE3	O/P	LVTTL O/P	LVTTL level data output
12	RXEE4	O/P	LVTTL O/P	LVTTL level data output
13	RXEE5	O/P	LVTTL O/P	LVTTL level data output
14	RXEE6	O/P	LVTTL O/P	LVTTL level data output
15	VSS0	GND	LVTTL O/P PWR	Ground pin for LVTTL outputs and digital circuitry
16	VDD0	VDD	LVTTL O/P PWR	Power supply pin for LVTTL outputs and digital circuitry
17	RXED0	O/P	LVTTL O/P	LVTTL level data output
18	RXED1	O/P	LVTTL O/P	LVTTL level data output
19	RXED2	O/P	LVTTL O/P	LVTTL level data output
20	RXED3	O/P	LVTTL O/P	LVTTL level data output
21	RXED4	O/P	LVTTL O/P	LVTTL level data output
22	RXED5	O/P	LVTTL O/P	LVTTL level data output
23	RXED6	O/P	LVTTL O/P	LVTTL level data output
24	VSSR0	GND	RX LOGIC	Ground pin for logic
25	VDDR0	VDD	RX LOGIC	Power supply for logic
26	RXEC0	O/P	LVTTL O/P	LVTTL level data output
27	RXEC1	O/P	LVTTL O/P	LVTTL level data output
28	RXEC2	O/P	LVTTL O/P	LVTTL level data output
29	RXEC3	O/P	LVTTL O/P	LVTTL level data output
30	RXEC4	O/P	LVTTL O/P	LVTTL level data output
31	RXEC5	O/P	LVTTL O/P	LVTTL level data output
32	VSS1	GND	LVTTL O/P PWR	Ground pin for LVTTL outputs and digital circuitry
33	VDD1	VDD	LVTTL O/P PWR	Power supply pin for LVTTL outputs and digital circuitry
34	RXEC6	O/P	LVTTL O/P	LVTTL level data output
35	RXEB0	O/P	LVTTL O/P	LVTTL level data output
36	RXEB1	O/P	LVTTL O/P	LVTTL level data output
37	RXEB2	O/P	LVTTL O/P	LVTTL level data output
38	RXEB3	O/P	LVTTL O/P	LVTTL level data output
39	RXEB4	O/P	LVTTL O/P	LVTTL level data output
40	RXEB5	O/P	LVTTL O/P	LVTTL level data output
41	RXEB6	O/P	LVTTL O/P	LVTTL level data output
42	VSSR1	GND	RX LOGIC	Ground pin for logic
43	VDDR1	VDD	RX LOGIC	Power supply for logic
44	RCLKOUT	O/P	LVTTL O/P	LVTTL level clock output
45	VSS2	GND	LVTTL O/P PWR	Ground pin for LVTTL outputs and digital circuitry

DS90C3202 Pin Descriptions (Continued)

Pin No.	Pin Name	I/O	Pin Type	Description
46	VDD2	VDD	LVTTTL O/P PWR	Power supply pin for LVTTTL outputs and digital circuitry
47	RXEA0	O/P	LVTTTL O/P	LVTTTL level data output
48	RXEA1	O/P	LVTTTL O/P	LVTTTL level data output
49	RXEA2	O/P	LVTTTL O/P	LVTTTL level data output
50	RXEA3	O/P	LVTTTL O/P	LVTTTL level data output
51	RXEA4	O/P	LVTTTL O/P	LVTTTL level data output
52	RXEA5	O/P	LVTTTL O/P	LVTTTL level data output
53	RXEA6	O/P	LVTTTL O/P	LVTTTL level data output
54	VSS3	GND	LVTTTL O/P PWR	Ground pin for LVTTTL outputs and digital circuitry
55	VDD3	VDD	LVTTTL O/P PWR	Power supply pin for LVTTTL outputs and digital circuitry
56	RXOE0	O/P	LVTTTL O/P	LVTTTL level data output
57	RXOE1	O/P	LVTTTL O/P	LVTTTL level data output
58	RXOE2	O/P	LVTTTL O/P	LVTTTL level data output
59	RXOE3	O/P	LVTTTL O/P	LVTTTL level data output
60	RXOE4	O/P	LVTTTL O/P	LVTTTL level data output
61	RXOE5	O/P	LVTTTL O/P	LVTTTL level data output
62	RXOE6	O/P	LVTTTL O/P	LVTTTL level data output
63	RXOD0	O/P	LVTTTL O/P	LVTTTL level data output
64	VSS4	GND	LVTTTL O/P PWR	Ground pin for LVTTTL outputs and digital circuitry
65	VDD4	VDD	LVTTTL O/P PWR	Power supply pin for LVTTTL outputs and digital circuitry
66	RXOD1	O/P	LVTTTL O/P	LVTTTL level data output
67	RXOD2	O/P	LVTTTL O/P	LVTTTL level data output
68	RXOD3	O/P	LVTTTL O/P	LVTTTL level data output
69	RXOD4	O/P	LVTTTL O/P	LVTTTL level data output
70	RXOD5	O/P	LVTTTL O/P	LVTTTL level data output
71	RXOD6	O/P	LVTTTL O/P	LVTTTL level data output
72	RXOC0	O/P	LVTTTL O/P	LVTTTL level data output
73	RXOC1	O/P	LVTTTL O/P	LVTTTL level data output
74	RXOC2	O/P	LVTTTL O/P	LVTTTL level data output
75	RXOC3	O/P	LVTTTL O/P	LVTTTL level data output
76	RXOC4	O/P	LVTTTL O/P	LVTTTL level data output
77	RXOC5	O/P	LVTTTL O/P	LVTTTL level data output
78	RXOC6	O/P	LVTTTL O/P	LVTTTL level data output
79	RXOB0	O/P	LVTTTL O/P	LVTTTL level data output
80	RXOB1	O/P	LVTTTL O/P	LVTTTL level data output
81	RXOB2	O/P	LVTTTL O/P	LVTTTL level data output
82	RXOB3	O/P	LVTTTL O/P	LVTTTL level data output
83	RXOB4	O/P	LVTTTL O/P	LVTTTL level data output
84	RXOB5	O/P	LVTTTL O/P	LVTTTL level data output
85	RXOB6	O/P	LVTTTL O/P	LVTTTL level data output
86	VDDR2	VDD	RX LOGIC	Power supply for logic
87	VSSR2	GND	RX LOGIC	Ground pin for logic
88	RXOA0	O/P	LVTTTL O/P	LVTTTL level data output
89	RXOA1	O/P	LVTTTL O/P	LVTTTL level data output
90	RXOA2	O/P	LVTTTL O/P	LVTTTL level data output
91	RXOA3	O/P	LVTTTL O/P	LVTTTL level data output

DS90C3202 Pin Descriptions (Continued)

Pin No.	Pin Name	I/O	Pin Type	Description
92	RXOA4	O/P	LVTTTL O/P	LVTTTL level data output
93	RXOA5	O/P	LVTTTL O/P	LVTTTL level data output
94	RXOA6	O/P	LVTTTL O/P	LVTTTL level data output
95	VDD5	VDD	LVTTTL O/P PWR	Power supply pin for LVTTTL outputs and digital circuitry
96	VSS5	GND	LVTTTL O/P PWR	Ground pin for LVTTTL outputs and digital circuitry
97	RESRVD	I/P	LVTTTL I/P (pulldown)	Tie to VSS for correct functionality
98	MODE1	I/P	Digital (pulldown)	“ODD” Bank Enable 0 = LVTTTL ODD OUTPUTS DISABLED (Data Output Low) 1 = LVTTTL ODD OUTPUTS ENABLED
99	VSSL	GND	LVDS PWR	Ground pin for LVDS
100	VDDL	VDD	LVDS PWR	Power supply pin for LVDS
101	RXOA-	I/P	LVDS I/P	Negative LVDS differential data input
102	RXOA+	I/P	LVDS I/P	Positive LVDS differential data input
103	RXOB-	I/P	LVDS I/P	Negative LVDS differential data input
104	RXOB+	I/P	LVDS I/P	Positive LVDS differential data input
105	RXOC-	I/P	LVDS I/P	Negative LVDS differential data input
106	RXOC+	I/P	LVDS I/P	Positive LVDS differential data input
107	RXOD-	I/P	LVDS I/P	Negative LVDS differential data input
108	RXOD+	I/P	LVDS I/P	Positive LVDS differential data input
109	RXOE-	I/P	LVDS I/P	Negative LVDS differential data input
110	RXOE+	I/P	LVDS I/P	Positive LVDS differential data input
111	VSSL	GND	LVDS PWR	Ground pin for LVDS
112	VSSL	GND	LVDS PWR	Ground pin for LVDS
113	VDDL	VDD	LVDS PWR	Power supply pin for LVDS
114	VDDL	VDD	LVDS PWR	Power supply pin for LVDS
115	RCLKIN-	I/P	LVDS I/P	Negative LVDS differential clock input
116	RCLKIN+	I/P	LVDS I/P	Positive LVDS differential clock input
117	RXEA-	I/P	LVDS I/P	Negative LVDS differential data input
118	RXEA+	I/P	LVDS I/P	Positive LVDS differential data input
119	RXEB-	I/P	LVDS I/P	Negative LVDS differential data input
120	RXEB+	I/P	LVDS I/P	Positive LVDS differential data input
121	RXEC-	I/P	LVDS I/P	Negative LVDS differential data input
122	RXEC+	I/P	LVDS I/P	Positive LVDS differential data input
123	RXED-	I/P	LVDS I/P	Negative LVDS differential data input
124	RXED+	I/P	LVDS I/P	Positive LVDS differential data input
125	RXEE-	I/P	LVDS I/P	Negative LVDS differential data input
126	RXEE+	I/P	LVDS I/P	Positive LVDS differential data input
127	MODE0	I/P	Digital (pulldown)	“EVEN” Bank Enable 0 = LVTTTL EVEN OUTPUTS DISABLED (Data Output Low) 1 = LVTTTL EVEN OUTPUTS ENABLED
128	RFB	I/P	Digital (pulldown)	Rising Falling Bar (<i>Figure 9</i>) 0 = FALLING EDGE DATA STROBE 1 = RISING EDGE DATA STROBE

Two-Wire Serial Communication Interface Description

The DS90C3202 operates as a slave on the Serial Bus, so the S2CLK line is an input (no clock is generated by the DS90C3202) and the S2DAT line is bi-directional. DS90C3202 has a fixed 7bit slave address. The address is not user configurable in anyway.

A zero in front of the register address is required. For example, to access register 0x0Fh, "0F" is the correct way of accessing the register.

COMMUNICATING WITH THE DS90C3202 CONTROL REGISTERS

There are 32 data registers (one byte each) in the DS90C3202, and can be accessed through 32 addresses. All registers are predefined as read only or read and write. The DS90C3202 slave state machine does not require an internal clock and it supports only byte read and write. Page mode is not supported. The 7bit binary address is 0111110. All seven bits are hardwired internally.

Reading the DS90C3202 can take place either of three ways:

1. If the location latched in the data register addresses is correct, then the read can simply consist of a slave address byte, followed by retrieving the data byte.
2. If the data register address needs to be set, then a slave address byte, data register address will be sent first, then the master will repeat start, send the slave address byte and data byte to accomplish a read.
3. When performing continuous read operations, another write (or read) instruction in between reads needs to be completed in order for the two-wire serial interface module to read repeatedly.

The data byte has the most significant bit first. At the end of a read, the DS90C3202 can accept either Acknowledge or No Acknowledge from the Master (No Acknowledge is typically used as a signal for the slave that the Master has read its last byte).

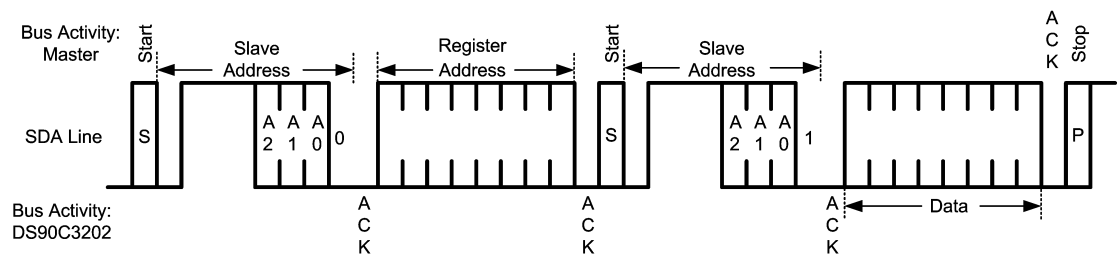

20147119

FIGURE 17. Byte Read

The master must generate a Start by sending the 7-bit slave address plus a 0 first, and wait for acknowledge from DS90C3202. When DS90C3202 acknowledges (the 1st ACK) that the master is calling, the master then sends the data register address byte and waits for acknowledge from the slave. When the slave acknowledges (the 2nd ACK), the master repeats the "Start" by sending the 7-bit slave address plus a 1 (indicating that READ operation is in progress) and

waits for acknowledge from DS90C3202. After the slave responds (the 3rd ACK), the slave sends the data to the bus and waits for acknowledge from the master. When the master acknowledges (the 4th ACK), it generates a "Stop". This completes the "READ".

A **Write** to the DS90C3202 will always include the slave address, data register address byte, and a data byte.

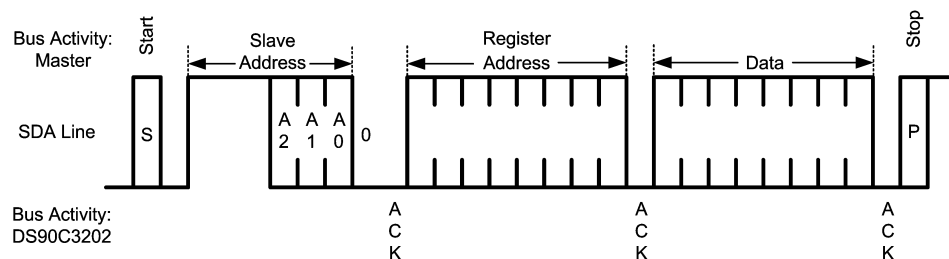

20147120

FIGURE 18. Byte Write

The master must generate a "Start" by sending the 7-bit slave address plus a 0 and wait for acknowledge from DS90C3202. When DS90C3202 acknowledges (the 1st ACK) that the master is calling, the master then sends the data register address byte and waits for acknowledge from

the slave. When the slave acknowledges (the 2nd ACK), the master sends the data byte and wait for acknowledge from the slave. When the slave acknowledges (the 3rd ACK), the master generates a "Stop". This completes the "WRITE".

DS90C3202 Two-Wire Serial Interface Register Table

Address	R/W	RESET	Bit #	Description	Default Value
0d/0h	R	PWDN	[7:0]	Vender ID low byte[7:0] = 05h	0000_0101
1d/1h	R	PWDN	[7:0]	Vender ID high byte[15:8] =13h	0001_0011
2d/2h	R	PWDN	[7:0]	Device ID low byte[7:0] = 28h	0010_1000
3d/3h	R	PWDN	[7:0]	Device ID high byte 15:8] = 67h	0110_0111
4d/4h	R	PWDN	[7:0]	Device revision [7:0] = 00h to begin with	0000_0000
5d/5h	R	PWDN	[7:0]	Low frequency limit, 8Mhz = 8h	0000_1000
6d/6h	R	PWDN	[7:0]	High frequency limit 135Mhz = 87h = 0000_0000_1000_0111	1000_0111
7d/7h	R	PWDN	[7:0]	Reserved	0000_0000
8d/8h	R	PWDN	[7:0]	Reserved	0000_0000
9d/9h	R	PWDN	[7:0]	Reserved	0000_0000
10d/ah	R	PWDN	[7:0]	Reserved	0000_0000
11d/bh	R	PWDN	[7:0]	Reserved	0000_0000
20d/14h	R/W	None	[7:0]	Reserved	0000_0000
21d/15h	R/W	None	[7:0]	Reserved	0000_0000
22d/16h	R/W	None	[7:3]	Reserved	0000_0000
			[2:0]	LVDS input skew control for CLK channel, 000 (default) applies to no delay added, ONE buffer delay per step adjustment towards Tsetup improvement	
23d/17h	R/W	None	[7]	Reserved	0000_0000
			[6:4]	LVDS input skew control for RXO channel B, 000 (default) applies to no delay added, ONE buffer delay per step adjustment towards Thold improvements	
			[3]	Reserved	
			[2:0]	LVDS input skew control for RXO channel C, 000 (default) applies to no delay added, ONE buffer delay per step adjustment towards Thold improvements	
24d/18h	R/W	None	[7]	Reserved	0000_0000
			[6:4]	LVDS input skew control for RXO channel D, 000 (default) applies to no delay added, ONE buffer delay per step adjustment towards Thold improvements	
			[3]	Reserved	
			[2:0]	LVDS input skew control for RXO channel E, 000 (default) applies to no delay added, ONE buffer delay per step adjustment towards Thold improvements	
25d/19h	R/W	None	[7]	Reserved	0000_0000
			[6:4]	LVDS input skew control for RXO channel A, 000 (default) applies to no delay added, ONE buffer delay per step adjustment towards Thold improvements	
			[3]	Reserved	
			[2:0]	LVDS input skew control for RXE channel A, 000 (default) applies to no delay added, ONE buffer delay per step adjustment towards Thold improvements	

DS90C3202 Two-Wire Serial Interface Register Table (Continued)

Address	R/W	RESET	Bit #	Description	Default Value
26d/1ah	R/W	None	[7]	Reserved	0000_0000
			[6:4]	LVDS input skew control for RXE channel B, 000 (default) applies to no delay added, ONE buffer delay per step adjustment towards Thold improvements	
			[3]	Reserved	
			[2:0]	LVDS input skew control for RXE channel C, 000 (default) applies to no delay added, ONE buffer delay per step adjustment towards Thold improvements	
27d/1bh	R/W	None	[7]	Reserved	0000_0000
			[6:4]	LVDS input skew control for RXE channel D, 000 (default) applies to no delay added, ONE buffer delay per step adjustment	
			[3]	Reserved	
			[2:0]	LVDS input skew control for RXE channel E, 000 (default) applies to no delay added, ONE buffer delay per step adjustment towards Thold improvements	
28d/1ch	R/W	None	[7:3]	Reserved	0000_0000
			[2]	LVTTTL output transition time control for CLK 0: Tr/Tf = 1.0ns (default) 1: Tr/Tf = 1.5ns	
			[1]	LVTTTL output transition time control for RXE 0: Tr/Tf = 1.5ns (default) 1: Tr/Tf = 2.5ns	
			[0]	LVTTTL output transition time control for RXO 0: Tr/Tf = 1.5ns (default) 1: Tr/Tf = 2.5ns	
29d/1dh	R/W	None	[7:3]	Reserved	0000_0000
			[2:1]	LVTTTL output setup and hold time control 00: balanced setup and hold time (default) 01: setup time is increased from default position by 1UI & hold time is reduced from default position by 1UI 10: setup time is decreased from default position by 1UI & hold time is reduced from default position by 1UI 11: setup time is increased from default position by 2UI & hold time is increased from default position by 2UI	
			[0]	LVTTTL output PTO control 1: PTO disabled, all outputs setup time are only controlled by contents of [2:1] 0: PTO enabled (default) Group1: CLK to latch Data is re-assigned earlier by 0.5UI respect to the normal centered position if only PTO option enabled; but PTO option and (Tsetup or Thold) adjustment can co-exist Group2: CLK to latch Data stays as the normal centered position if only PTO option enabled; but PTO option and (Tsetup or Thold) adjustment can co-exist	

DS90C3202 Two-Wire Serial Interface Register Table (Continued)

Address	R/W	RESET	Bit #	Description	Default Value
30d/1eh	R/W	None	[7:5]	Reserved	0000_0000
			[4]	I/O disable control for RXE channel A, 1: disable, 0: enable (default)	
			[3]	I/O disable control for RXE channel B, 1: disable, 0: enable (default)	
			[2]	I/O disable control for RXE channel C, 1: disable, 0: enable (default)	
			[1]	I/O disable control for RXE channel D, 1: disable, 0: enable (default)	
			[0]	I/O disable control for RXE channel E, 1: disable, 0: enable (default)	
31d/1fh	R/W	None	[7:6]	11; LVTTTL Outputs available as long as "NO CLK" is at HIGH regardless PLL lock or not 10; LVTTTL Outputs available after 1K of CLK cycles detected & PLL generated strobes are within 0.5UI respect to REFCLK 01; LVTTTL Outputs available after 2K of CLK cycles detected 00: default ; LVTTTL Outputs available after 1K of CLK cycles detected	0000_0000
			[5]	0: default; to select the size of wait counter between 1K or 2K, default is 1K	
			[4]	I/O disable control for RXO channel A, 1: disable, 0: enable (default)	
			[3]	I/O disable control for RXO channel B, 1: disable, 0: enable (default)	
			[2]	I/O disable control for RXO channel C, 1: disable, 0: enable (default)	
			[1]	I/O disable control for RXO channel D, 1: disable, 0: enable (default)	
			[0]	I/O disable control for RXO channel E, 1: disable, 0: enable (default)	

Note 13: Registers with RESET designated with "None" requires device to be power cycled to reset register values to their default state.

Physical Dimensions inches (millimeters) unless otherwise noted

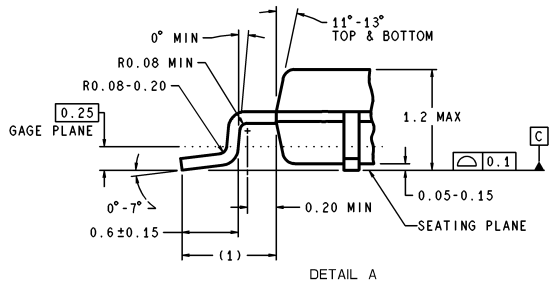
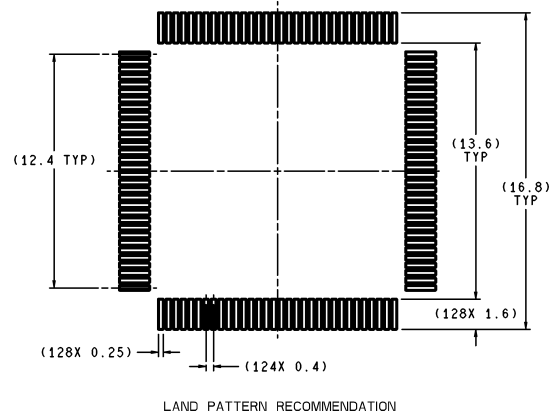
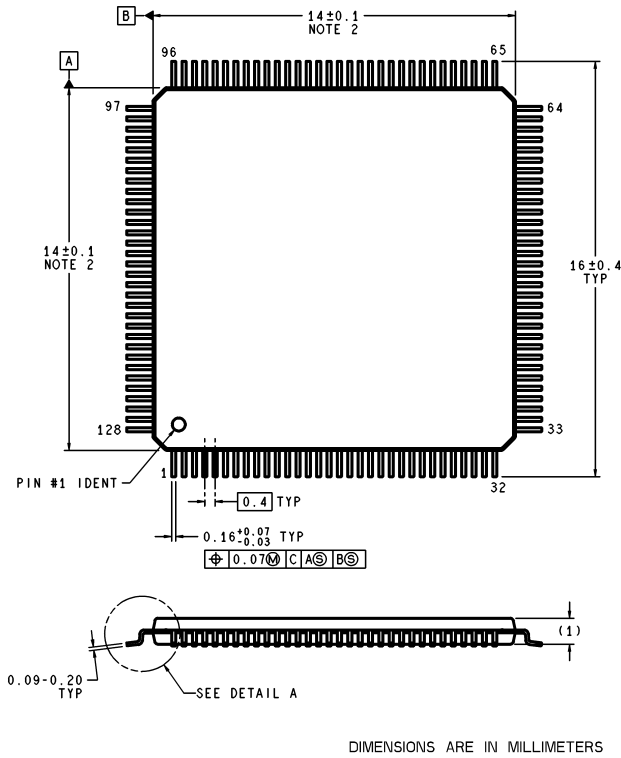

VJX128A (Rev A)

128-Pin TQFP Package
Order Number DS90C3202VS
NS Package Number VJX128A

National does not assume any responsibility for use of any circuitry described, no circuit patent licenses are implied and National reserves the right at any time without notice to change said circuitry and specifications.

For the most current product information visit us at www.national.com.

LIFE SUPPORT POLICY

NATIONAL'S PRODUCTS ARE NOT AUTHORIZED FOR USE AS CRITICAL COMPONENTS IN LIFE SUPPORT DEVICES OR SYSTEMS WITHOUT THE EXPRESS WRITTEN APPROVAL OF THE PRESIDENT AND GENERAL COUNSEL OF NATIONAL SEMICONDUCTOR CORPORATION. As used herein:

1. Life support devices or systems are devices or systems which, (a) are intended for surgical implant into the body, or (b) support or sustain life, and whose failure to perform when properly used in accordance with instructions for use provided in the labeling, can be reasonably expected to result in a significant injury to the user.
2. A critical component is any component of a life support device or system whose failure to perform can be reasonably expected to cause the failure of the life support device or system, or to affect its safety or effectiveness.

BANNED SUBSTANCE COMPLIANCE

National Semiconductor follows the provisions of the Product Stewardship Guide for Customers (CSP-9-111C2) and Banned Substances and Materials of Interest Specification (CSP-9-111S2) for regulatory environmental compliance. Details may be found at: www.national.com/quality/green.

Lead free products are RoHS compliant.

 **National Semiconductor**
Americas Customer Support Center
 Email: new.feedback@nsc.com
 Tel: 1-800-272-9959

National Semiconductor
Europe Customer Support Center
 Fax: +49 (0) 180-530 85 86
 Email: europe.support@nsc.com
 Deutsch Tel: +49 (0) 69 9508 6208
 English Tel: +44 (0) 870 24 0 2171
 Français Tel: +33 (0) 1 41 91 8790

National Semiconductor
Asia Pacific Customer Support Center
 Email: ap.support@nsc.com

National Semiconductor
Japan Customer Support Center
 Fax: 81-3-5639-7507
 Email: jpn.feedback@nsc.com
 Tel: 81-3-5639-7560