



## 1900L 19-inch LCD Touchmonitor User Guide

[Model ET1900L]



**Elo TouchSystems**  
**1900L 19-inch LCD Touchmonitor**  
**User Guide**

**Revision A**

**P/N E483389**

**Elo TouchSystems**

**1-800-EL TOUCH**

**[www.elotouch.com](http://www.elotouch.com)**

**Copyright © 2008 Tyco Electronics. All Rights Reserved.**

No part of this publication may be reproduced, transmitted, transcribed, stored in a retrieval system, or translated into any language or computer language, in any form or by any means, including, but not limited to, electronic, magnetic, optical, chemical, manual, or otherwise without prior written permission of Elo TouchSystems.

**Disclaimer**

The information in this document is subject to change without notice. Elo TouchSystems makes no representations or warranties with respect to the contents hereof, and specifically disclaims any implied warranties of merchantability or fitness for a particular purpose. Elo TouchSystems reserves the right to revise this publication and to make changes from time to time in the content hereof without obligation of Elo TouchSystems to notify any person of such revisions or changes.

**Trademark Acknowledgments**

IntelliTouch, APR (Acoustic Pulse Recognition), Elo TouchSystems, TE Logo, and Tyco Electronics are trademarks. Other product names mentioned herein may be trademarks or registered trademarks of their respective companies. Elo TouchSystems claims no interest in trademarks other than its own.

# Table of Contents

<b>Chapter 1: Introduction .....</b>	<b>5</b>
About the Product .....	5
Precautions .....	6
<b>Chapter 2: Installation and Setup .....</b>	<b>7</b>
Unpacking Your Touchmonitor .....	8
Connecting the Cables to the Touchmonitor and Computer .....	9
Installing the Touch Driver .....	10
Monitor Overview and Dimensions .....	11
Monitor Mounting and Orientation .....	12
<b>Chapter 3: Operation .....</b>	<b>15</b>
About Touchmonitor Adjustments .....	15
On-Screen Display (OSD) Control Panel .....	16
Preset Display Modes .....	20
Speakers and Audio Features .....	21
<b>Chapter 4: Troubleshooting .....</b>	<b>22</b>
Solutions to Common Problems .....	22
Technical Support .....	23
<b>Appendix A: Touchmonitor Safety .....</b>	<b>24</b>
Care and Handling of Your Touchmonitor .....	25
Warning .....	25
Waste Electrical and Electronic Equipment (WEEE) Directive .....	25
<b>Appendix B: Technical Specifications .....</b>	<b>26</b>
1900L Specifications .....	26
<b>Regulatory Information .....</b>	<b>29</b>
<b>Warranty .....</b>	<b>32</b>

## INTRODUCTION

### About the Product

---

The Elo TouchSystems 1900L touchmonitor senses touch on the display in a completely new way, by recognizing the unique pattern of sounds. Consisting only of a glass overlay mounted in front of the LCD panel, Elo's 1900L zero-bezel Acoustic Pulse Recognition (APR) delivers benefits that combine the ultimate in optical qualities with a stylish, easy to clean, seamless front face.

Wide-aspect displays like the Elo 1900L are easier to use and incorporate into the workplace than traditional desktop touchmonitors. Wide-screen format displays allow extra content on screen and are ideal in corporate environments for spreadsheets, publishing, and dual-window applications.

The 1900L is available in both zero-bezel APR and IntelliTouch Surface Acoustic Wave touch technologies.

Typical applications for the 1900L include: point-of-sale (POS), point-of-service, digital signage, loyalty systems, kiosk information systems, light industrial shop-floor automation and home control.

- Wide-screen format provides more application space
- Sleek, integrated design offers a stylish look for public venues
- AC and DC power for maximum input flexibility
- User-lockable on-screen display – designed for public access
- Adjustable height stand provides the flexibility to be raised or lowered to meet the application's height requirements

- VGA and DVI-D video input (DVI-D not available in Europe)
- Space-saving built-in speakers
- Sealed screen is resistant to water, dust, grease
- One-time factory calibration for easy deployment and integration
- Pure glass construction provides superior optical performance and the true-flat surface is easy to clean
- VESA compliance makes wall or arm-mounting possible

For more detailed information, please visit our website:  
**[www.elotouch.com](http://www.elotouch.com)**.

## Precautions

---

Follow all warnings, precautions, and maintenance as recommended in this user's manual to maximize the life of the unit. See Appendix A for more information on touchmonitor safety.

CHAPTER

# 2

## INSTALLATION AND SETUP

This chapter discusses how to install and set up your LCD touchmonitor and how to install Elo TouchSystems driver software.

## Unpacking Your Touchmonitor

---

Check that the following items are present:

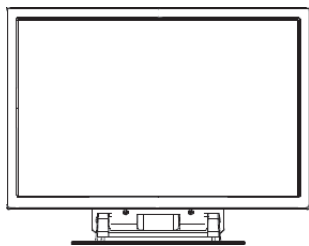

Touchmonitor

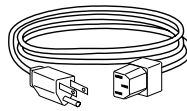

Power Cable



Input Audio  
Cable

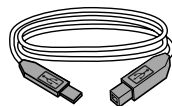

USB Cable



Serial Cable  
(not available with  
APR models)



(not available with  
APR models)



VGA Video cable



DVI-D Cable  
(not available with  
European models)

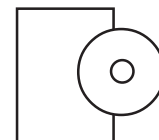

TouchTools or APR CD and  
Quick Install Guide



## Connecting the Cables to the Touchmonitor and Computer

---

### Connector Panel Underneath the Monitor

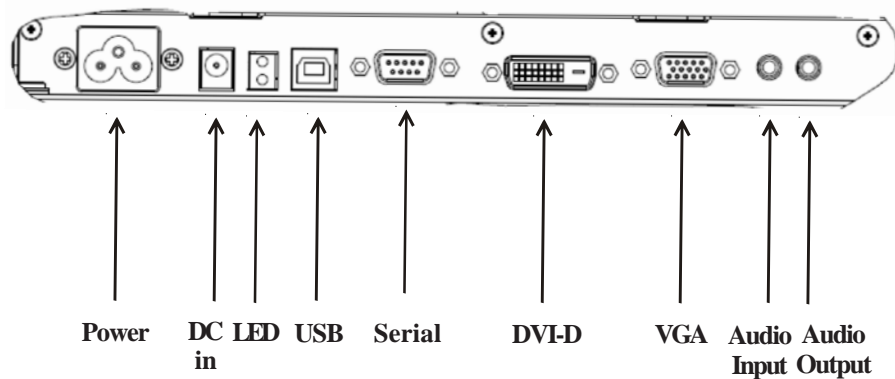

#### To connect the touchmonitor to the computer:

- 1 Tilt the monitor to reveal the connector panel in the recessed area underneath the bottom edge of the monitor.
- 2 Connect the AC power cable to the connector panel and connect the other end to the power outlet.
- 3 Connect either the USB cable **OR** the serial cable to the connector panel. **Note: Do not use both.** This cable connects the touchmonitor to your computer. Attach the other end to your computer.
- 4 Connect the video cable (VGA) or the DVI-D cable to the connector panel. Tighten by turning the two thumb screws clockwise to ensure proper grounding. Connect the other end to your computer.
- 5 Connect the audio cable to the Audio Input on the connector panel and connect the other end to your computer.
- 6 Press the power button on the side panel of the monitor to turn on the monitor.

## Installing the Touch Driver

---

Your Elo touchmonitor is Plug-and-Play compliant. Information on the video capabilities of the touchmonitor is sent to the video display adapter when the computer's operating system starts. If the computer's operating system detects the touchmonitor, follow the instructions on the screen to install a generic Plug-and-Play monitor.

Elo TouchSystems provides touchscreen driver software that allows your touchmonitor to work with your computer. Drivers are located on the enclosed CD.

The latest versions of drivers and driver information for all operating systems, including those that are not included with the CD, are available on the Elo TouchSystems website at [www.elotouch.com/support/downloads/](http://www.elotouch.com/support/downloads/).

To install the Touch Driver, follow the steps below:

- 1 Insert the TouchTools or APR CD in your computer's CD-ROM drive.
- 2 Click on **Install Driver for This Computer**.
- 3 Follow the on-screen instructions to complete the installation.

***If there are no on-screen instructions when you install the TouchTools or APR CD :***

- 1 Click **Start > Run**.
- 2 Click the **Browse** button to locate the EloCd.exe program on the CD-ROM.
- 3 Click **Open**, then **OK** to run EloCd.exe.
- 4 Follow the directions on the screen to complete the driver installation.

## Monitor Overview and Dimensions

---

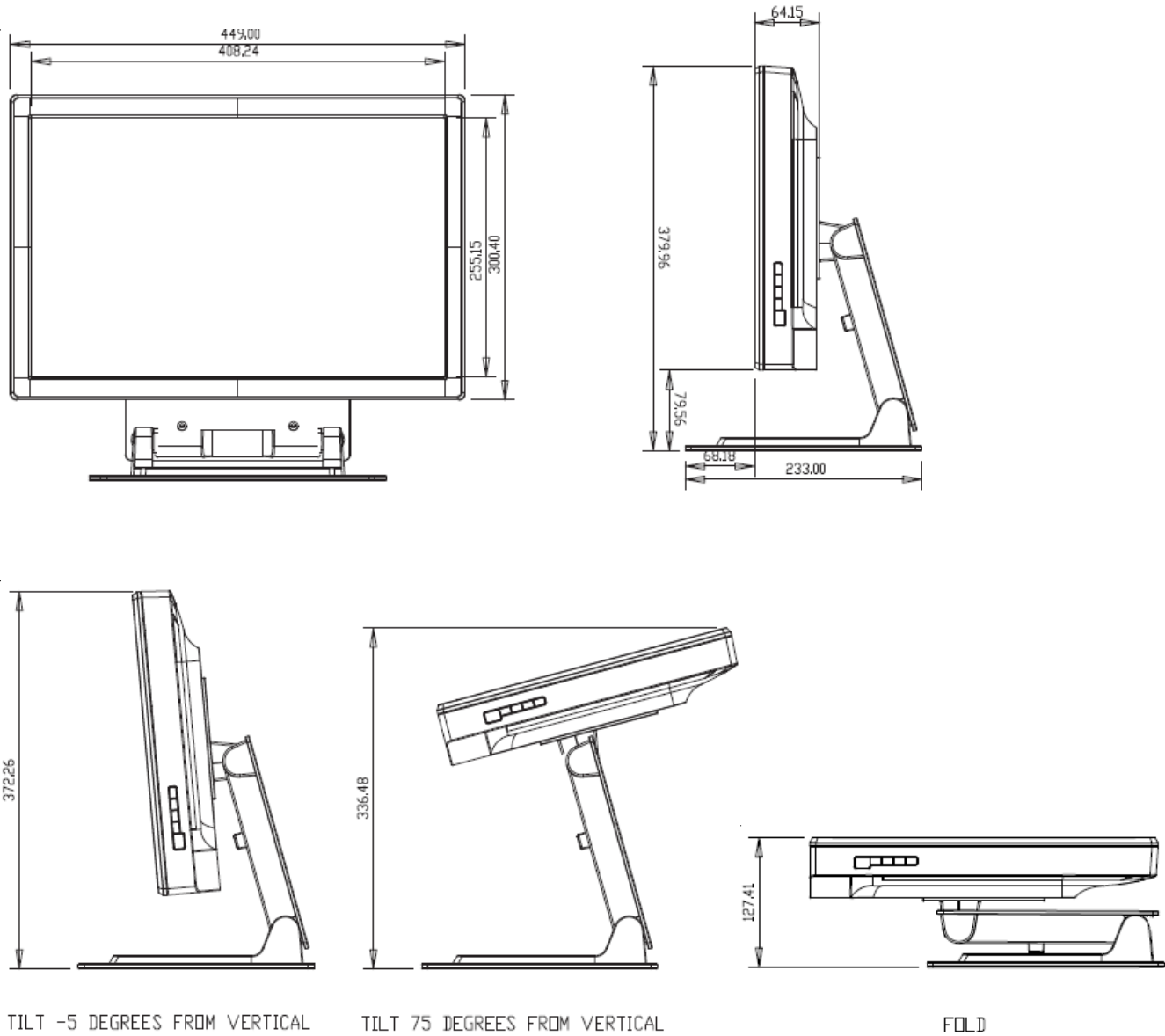

**Note:**

Dimensions are in millimeters.

Detailed mechanical drawings can be found at: [www.elotouch.com](http://www.elotouch.com)

## Monitor Mounting and Orientation

---

### Option 1— Mount on Flat Surface with Stand

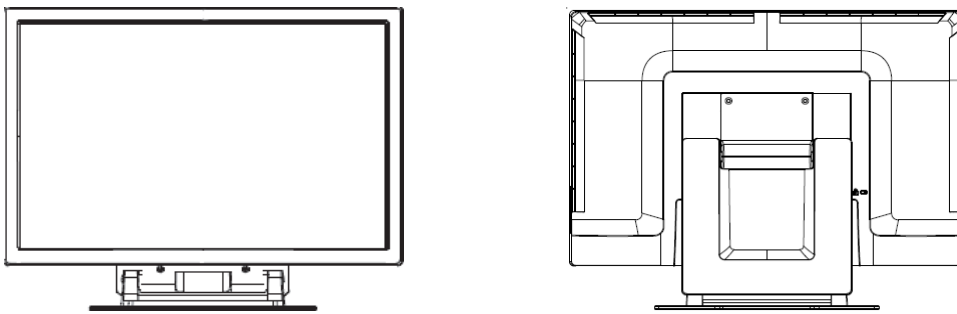

Landscape Orientation shown above

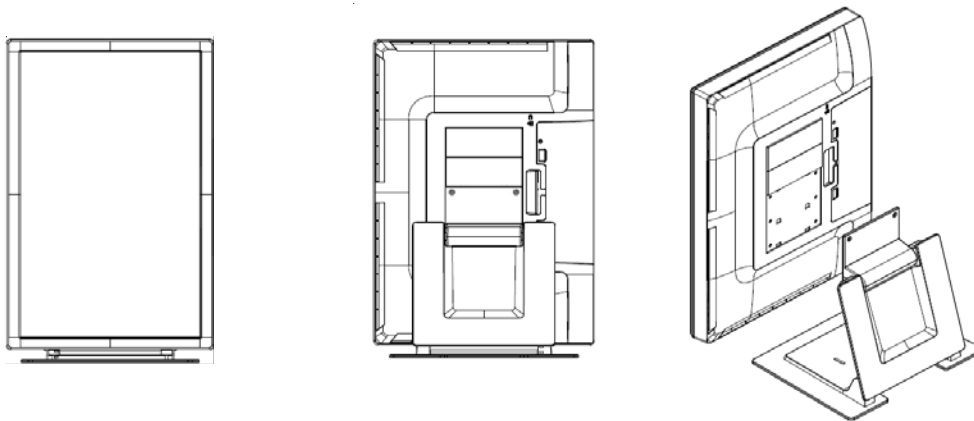

Portrait Orientation shown above

## Monitor Mounting and Orientation (continued)

### Option 2 — Mount using VESA

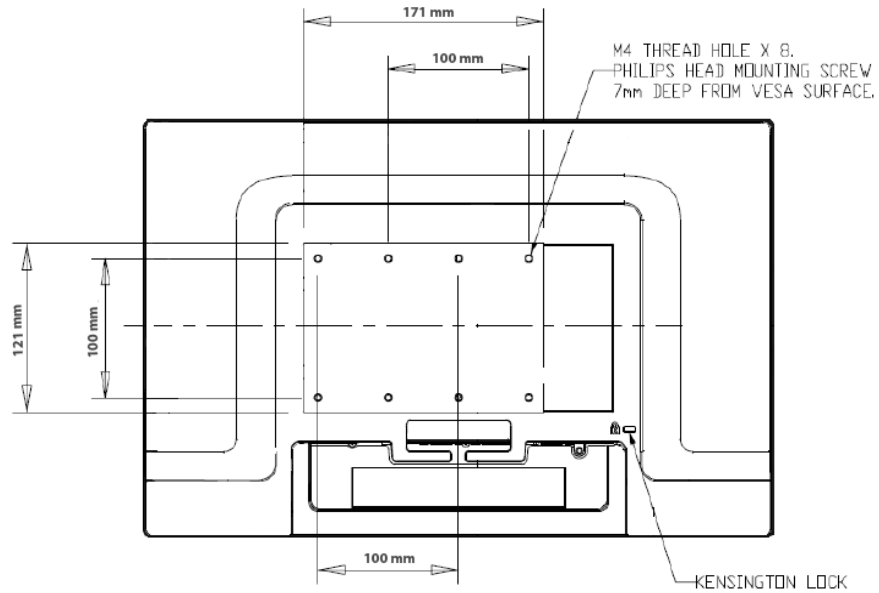

Rear view of monitor in landscape orientation shown above

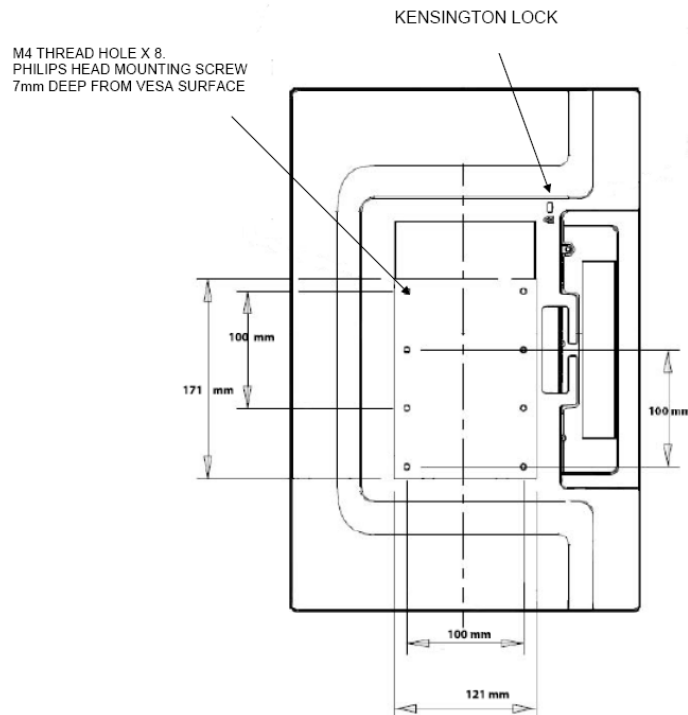

Rear view of monitor in portrait orientation shown above

## Monitor Mounting and Orientation (continued)

---

### Attaching the Stand to a Mounting Surface

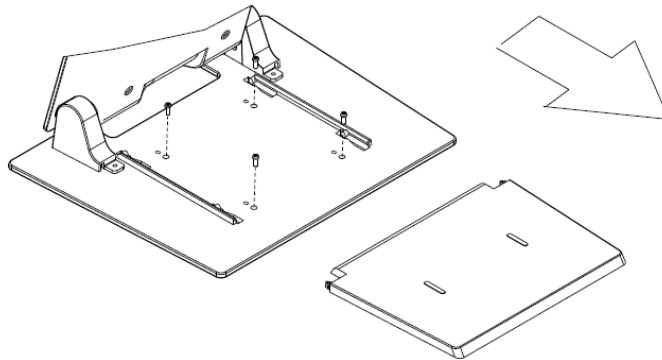

**Option 1 — Mounting from the top.**  
Slide out stand base cover. Use 4 screws to attach stand to surface.

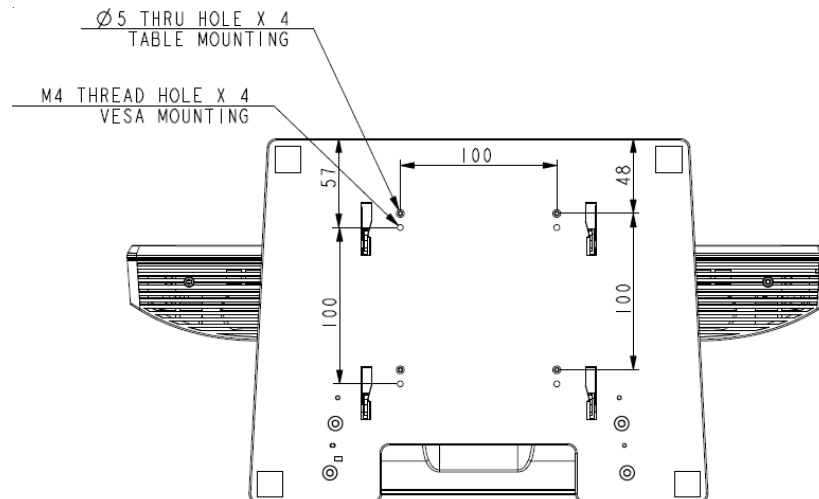

**Option 2 — Mounting from the bottom.**  
Attach to the surface using the holes shown above.

## OPERATION

## About Touchmonitor Adjustments

---

Your touchmonitor probably does not require adjustment. However, variations in video output and application may require adjustments to your touchmonitor to optimize the quality of the display.

For best performance, your video source should be at 1440 X 900 resolution, at 56–76 Hz refresh rate. Operating in other resolutions degrades video performance.

For input video outside the refresh rate and dot clock ranges, the monitor does not automatically adjust, but displays an “Out of Range” (OOR) message and the On-screen Display (OSD) menu, which ordinarily allows you to change monitor settings, is then disabled.

***Note: Do not operate the touchmonitor if you see the OOR message, or LCD damage may result. If you see the OOR message, set the video mode to one within the allowable range.***

## On-Screen Display (OSD) Control Panel

---

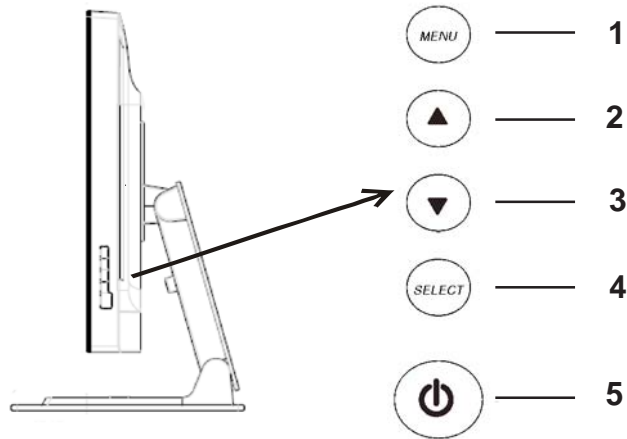

The On-Screen Display (OSD) control panel is located on the side of the monitor, as shown above.

### OSD Control Buttons

The OSD control buttons allow you to change settings on the monitor screen. The five buttons shown above are:

1	<b>MENU</b>
2	<b>UP</b>
3	<b>DOWN</b>
4	<b>SELECT</b>
5	<b>POWER</b>

### OSD Menu Functions

The control buttons have the following functions:

- MENU**      Displays or exits the OSD Menus
- UP ▲**      1) Enters brightness and/or contrast of the OSD (if no OSD is currently displayed on screen)  
2) Increases value of OSD adjustment choice  
3) Selects OSD choice counterclockwise



**DOWN ▼** 1) Adjusts audio volume or selects Mute option (if no OSD is currently displayed on screen)  
2) Decreases value of OSD adjustment choice

**SELECT** 1) Selects Analog or Digital  
2) Selects adjustment choices from the OSD menus.

**POWER** Turns the monitor on or off.  
After adjusting the values, the monitor automatically saves the changes.

### **OSD Lock/Unlock**

You can lock and unlock the OSD feature. The monitor is shipped with the OSD unlocked, no OSD can be displayed or used.

To lock the OSD:

- 1 Press the **MENU** button and **UP** button simultaneously for 2 seconds. A window appears displaying “OSD Unlock.”
- 2 Continue to hold the buttons down for another 2 seconds and the window toggles to “OSD Lock.”

### **Power Lock/Unlock**

You can lock and unlock the Power feature. When the power is locked, pressing the power switch does not turn off the monitor. The monitor is shipped with the power unlocked.

To lock the power:

- 1 Press the **MENU** button and the **DOWN** button simultaneously for 2 seconds. A window appears displaying “Power Unlock.”
- 2 Continue to hold the buttons down for another 2 seconds and the window toggles to “Power Lock.”

**NOTE:** By default, the OSD screen disappears if no input activities are detected for 30 seconds.

## OSD Control Options

### **Auto Adjust**

- Automatically adjusts video timing parameters (*VGA only*).

### **Luminance**

#### **Brightness**

- Adjusts the brightness.

#### **Contrast**

- Adjusts the contrast.

### **Image Setting (VGA only)**

#### **H. position**

- Moves the image left or right on the screen.

#### **V. position**

- Moves the image up or down on the screen.

#### **Clock**

- Stretches the image horizontally.

#### **Phase**

- Adjusts the phase of the dot clock to image data.

### **Color**

- Sets the color temperature.

### **Audio**

- Adjusts audio volume or selects Mute option.

### **OSD**

#### **OSD H. Position**

- Moves the OSD menu screen left or right.

#### **OSD V. Position**

- Moves the OSD menu screen up or down.

#### **OSD Timeout**

- Adjusts amount of time that the OSD menu is displayed.

### **Language**

- Selects the language used for the OSD menu from English, French, German, Spanish, Italian, Traditional Chinese, Simplified Chinese, or Japanese.

## **Recall**

### **Color Recall**

- Restores default color temperature settings.

### **Recall Defaults**

- Restores original factory settings for H-position, V-position, Clock, and Phase for the current video mode (*VGA only*).
- Restores original factory settings for all other parameters and video inputs, except language.

## **Miscellaneous**

### **Aspect Ratio**

- Selects Fill Screen or Fill to aspect ratio.

### **Sharpness**

- Adjusts sharpness of video.

### **DDCCI Function**

- Enables or disables the Display Data Channel Command Interface (DDCCI) function.

## **Display Information**

- Information is displayed at the bottom of the Main Menu regarding the input horizontal/vertical synchronizing signal.

## Preset Display Modes

---

The touchmonitor comes with preset settings for commonly used video modes. It automatically adjusts the picture size and centering for any of the video modes listed in *Appendix B, 1900L Specifications*, under “Preset Display Modes.”

## Speakers and Audio Features

---

The touchmonitor includes two built-in speakers. To use the speakers, plug in the audio cable to the **Audio Input** port shown in the illustration below, and connect the other end to your computer.

To use headphones, plug in the headphones to the **Audio Output** port shown in the illustration below. When headphones are connected, the sound plays through the headphones only.

### Connector Panel Underneath the Monitor

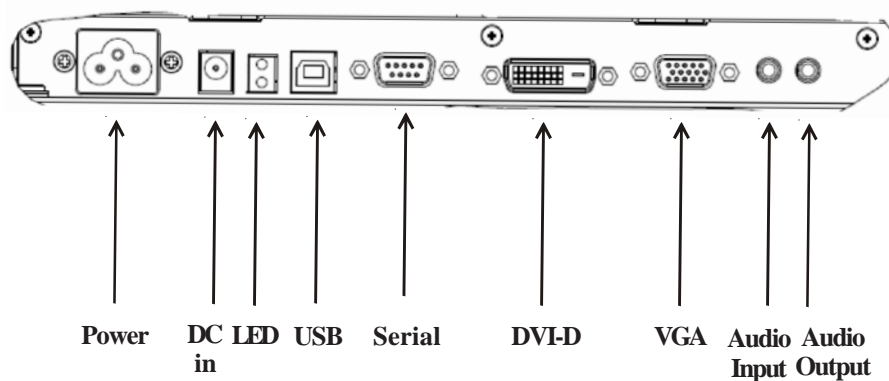

The volume and muting of the sound can be adjusted by using the “Audio” choice from the On-Screen Display (OSD) Control panel menu, as described on pages 16 through 18.

## TROUBLESHOOTING

If you are experiencing trouble with your touchmonitor, refer to the following table. If the problem persists, please contact your local dealer or our service center. Elo Technical Support numbers are listed on the next page.

### Solutions to Common Problems

Problem	Suggestion(s)
The monitor does not respond after you turn on the system	Check that the monitor's Power Switch is on. Turn off the power and check the monitor's power cord and signal cable for proper connection.
Characters on the screen are dim	Refer to the <i>On-Screen Display (OSD) Control Panel</i> section to adjust the brightness.
The screen is blank	During operation, the monitor screen may automatically turn off as a result of a computer Power Saving feature. Press any key on the computer's keyboard to see if the screen reappears. Refer to the <i>On-Screen Display (OSD) Control Panel</i> section to adjust the brightness.
Screen flashes when you first turn on the monitor	Turn the monitor off, then turn it on again.
"Out of Range" display	Check to see if the video mode or vertical frequency of your video source is outside the range of the touchmonitor. See Chapter 3 and Appendix B for more information on allowable video modes.
Touch doesn't work	Make sure the USB or serial cable is securely attached at both ends. Check that the driver is properly installed.

## Technical Support

---

To contact technical support online, please go to:  
**[www.elotouch.com/go/contactsupport](http://www.elotouch.com/go/contactsupport)**

To contact technical support by telephone, please call:  
**1-800-557-1458**

# A

## TOUCHMONITOR SAFETY

This manual contains information that is important for the proper setup and maintenance of your touchmonitor. Before setting up and powering on your touchmonitor, read through this manual, especially Chapter 2 (*Installation and Setup*), and Chapter 3 (*Operation*).

- 1** To reduce the risk of electric shock, follow all safety notices and never open the touchmonitor case.
- 2** Turn off the product before cleaning. (Please refer to *Care and Handling of Your Touchmonitor* on the following page for proper cleaning methods.)
- 3** Your touchmonitor is equipped with a 3-wire, grounding power cord. The power cord plug only fits into a grounded outlet. Do not attempt to fit the plug into an outlet that has not been configured for this purpose. Do not use a damaged power cord. Only use the power cord that comes with your Elo TouchSystems Touchmonitor. Use of an unauthorized power cord may invalidate your warranty.
- 4** The slots located on the sides and top of the touchmonitor case are for ventilation. Do not block or insert anything inside the ventilation slots.
- 5** It is important that your touchmonitor remains dry. Do not pour liquid into or onto your touchmonitor. If your touchmonitor becomes wet do not attempt to repair it yourself.



## Care and Handling of Your Touchmonitor

---

The following tips will help keep your Elo touchmonitor functioning at the optimal level.

- To avoid risk of electric shock, do not disassemble the touchmonitor. There are no user-serviceable parts inside the touchmonitor. Remember to unplug the touchmonitor from the power outlet before cleaning.
- Do not use alcohol (methyl, ethyl or isopropyl) or any strong solvent. Do not use thinner or benzene, abrasive cleaners or compressed air.
- To clean the touchmonitor housing, use a cloth lightly dampened with a mild detergent.
- Avoid getting liquids inside your touchmonitor. If liquid does get inside, have a qualified service technician check it before you power it on again.
- Do not wipe the touchscreen with anything abrasive that could scratch the surface.
- To clean the touchscreen, use window or glass cleaner. Put the cleaner on a clean cloth and wipe the touchscreen. *Never* apply the cleaner directly on the touchscreen .



### Warning

---

This product consists of devices that may contain mercury, which must be recycled or disposed of in accordance with local, state, or federal laws. (Within this system, the backlight lamps in the monitor display contain mercury.)

### Waste Electrical and Electronic Equipment (WEEE) Directive

---



In the European Union, this label indicates that this product should not be disposed of with household waste. It should be deposited at an appropriate facility to enable recovery and recycling.

APPENDIX

# B

TECHNICAL SPECIFICATIONS

## 1900L Specifications

---

<b>Model</b>	<b>ET1900L</b>
<b>LCD Display</b>	19" TFT active matrix panel
<b>Display Size</b>	408.24(H) x 255.15(V) mm
<b>Pixel Pitch</b>	.282(H) x .282(V) mm
<b>Preset Display Modes</b>	640 x 480 @ 60Hz 640 x 480 @ 66Hz 640 x 480 @ 72Hz 720 x 350 @ 70Hz 720 x 400 @ 70Hz 800 x 600 @ 56Hz 800 x 600 @ 60Hz 800 x 600 @ 72Hz 832 x 624 @ 75 Hz 1024 x 768 @ 60Hz 1024 x 768 @ 65Hz 1024 x 768 @ 72Hz 1024 x 768 @ 75Hz 1152 x 864 @ 75 Hz 1280 x 768 @ 65 Hz 1280 x 960 @ 60 Hz 1280 x 1024 @ 60Hz 1280 x 1024 @ 75 Hz 1360 x 768 @ 60 Hz 1366 x 768 @ 60 Hz 1440 x 900 @ 60 Hz 1680 x 1050 @ 60 Hz
<b>Native Resolution</b>	1440 x 900
<b>Contrast Ratio</b>	1000:1 (typical)
<b>Brightness</b>	No Touch: Typical 270 cd/m <sup>2</sup> IntelliTouch: Typical 270 cd/m <sup>2</sup> APR: Typical 270 cd/m <sup>2</sup>
<b>Response Time</b>	Rising and falling time: 5 ms (typical)

<b>Display Color</b>	16.7 Million
<b>Viewing Angle</b>	Vertical - 80° to 80° Horizontal - 80° to 80°
<b>Input Video Signal</b>	<ul style="list-style-type: none"> <li>• RGB Analog Video (0.7V p-p, 75 ohm; separate syncs, composite sync, or sync-on-green; TTL positive or negative)</li> <li>• DVI-D Video (not available with European models)</li> </ul>
<b>Input Video Range</b>	Horizontal scan frequency: 30 to 83 KHz Vertical frame rate range: 56 to 76 Hz
<b>Video Signal Connector</b>	Analog: 15-pin Female D-Sub Digital: Female DVI-D (not available with European models)
<b>VESA EDID file</b>	Version 1.3
<b>VESA MDCS protocol</b>	Version 2.0
<b>Two Internal Speakers</b>	2W rms, 3W peak (each)
<b>Touch Technology</b>	IntelliTouch or Acoustic Pulse Recognition
<b>Power Input</b>	Input: 100–240Vac, 47-63 Hz
<b>Operating Conditions</b>	Temperature: 0°C to 40°C Humidity: 20% to 80% (no condensation) Altitude: 0 to 3,658 m
<b>Storage Conditions</b>	Temperature: -20°C to 60°C Humidity: 10% to 90% (no condensation) Altitude: 0 to 12,192 m
<b>Weight</b>	9.03 Kg (unpackaged) 12.15 Kg (packaged)

## REGULATORY INFORMATION

---

### **I. Electrical Safety Information:**

A) Compliance is required with respect to the voltage, frequency, and current requirements indicated on the manufacturer's label. Connection to a different power source than those specified herein may result in improper operation, damage to the equipment, invalidation of warranty, or a fire hazard if the requirements are not followed.

B) There are no operator-serviceable parts inside this equipment. There are hazardous voltages generated by this equipment which constitute a safety hazard. Service should be provided only by a qualified service technician.

C) This equipment is provided with a detachable power cord which has an integral safety ground wire intended for connection to a grounded safety outlet.

1) Do not substitute the cord with other than the provided approved type. Under no circumstances use an adapter plug to connect to a 2-wire outlet as this defeats the continuity of the grounding wire.

2) The equipment requires the use of the ground wire as a part of the safety certification. Modification or misuse can provide a shock hazard that can result in serious injury or death.

3) Contact a qualified electrician or the manufacturer if there are questions about the installation prior to connecting the equipment to main power.

### **II. Emissions and Immunity Information**

A) Notice to Users in the United States: This equipment has been tested and found to comply with the limits for a Class B digital device, pursuant to Part 15 of FCC Rules. These limits are designed to provide reasonable protection against harmful interference in a residential or commercial installation. This equipment generates, uses, and can radiate radio frequency energy, and if not installed and used in accordance with the instructions, may cause harmful interference to radio communications.

B) Notice to Users in Canada: This equipment complies with the Class B limits for radio noise emissions from digital apparatus as established by the Radio Interference Regulations of Industry Canada.

C) Notice to Users in the European Union: Use only the provided power cords and interconnecting cabling provided with the equipment. Substitution of provided cords and cabling may compromise electrical safety or CE Mark Certification for emissions or immunity as required by the following standards: This Information Technology Equipment (ITE) is required to have a CE Mark on the manufacturer's label which means that the equipment has been tested to the following Directives and Standards:

This equipment has been tested to the requirements for the CE Mark as required by EMC Directive 89/336/EEC indicated in European Standard EN 55022 Class B and the Low Voltage Directive 73/23/EEC as indicated in European Standard EN 60950.

D) General Information to all Users: This equipment generates, uses and can radiate radio frequency energy. If not installed and used according to this manual, the equipment may cause interference with radio and television communications. There is, however, no guarantee that interference will not occur in any particular installation due to site-specific factors.

1) In order to meet emission and immunity requirements, the user must observe the following:

- a) Use only the provided I/O cables to connect this digital device with any computer.
- b) To ensure compliance, use only the provided manufacturer's approved power cord.
- c) The user is cautioned that changes or modifications to the equipment not expressly approved by the party responsible for compliance could void the user's authority to operate the equipment.

2) If this equipment appears to cause interference with radio or television reception, or any other device:

- a) Verify as an emission source by turning the equipment off and on.
- b) If you determine that this equipment is causing the

interference, try to correct the interference by using one or more of the following measures:

- i) Move the digital device away from the affected receiver.
- ii) Reposition (turn) the digital device with respect to the affected receiver.
- iii) Reorient the affected receiver's antenna.
- iv) Plug the digital device into a different AC outlet so the digital device and the receiver are on different branch circuits.
- v) Disconnect and remove any I/O cables that the digital device does not use. (Unterminated I/O cables are a potential source of high RF emission levels.)
- vi) Plug the digital device into only a grounded outlet receptacle. Do not use AC adapter plugs. (Removing or cutting the power cord ground may increase RF emission levels and may also present a lethal shock hazard to the user.)
- vii) If you need additional help, consult your dealer, manufacturer, or an experienced radio or television technician.

### **III. Agency Certifications**

The following Certifications have been issued for the monitor:

- Argentina
- Australia
- China
- China RoHS
- EU RoHS
- Europe CE
- FCC
- Japan VCCI
- Korea
- Mexico
- Russia
- Singapore
- Taiwan
- United States
- WEEE

## WARRANTY

---

Except as otherwise stated herein or in an order acknowledgment delivered to Buyer, Seller warrants to Buyer that the Product shall be free of defects in materials and workmanship. With the exception of the negotiated warranty periods; the warranty for the touchmonitor and components of the product is 3 years.

Seller makes no warranty regarding the model life of components. Seller's suppliers may at any time and from time to time make changes in the components delivered as Products or components. Buyer shall notify Seller in writing promptly (and in no case later than thirty (30) days after discovery) of the failure of any Product to conform to the warranty set forth above; shall describe in commercially reasonable detail in such notice the symptoms associated with such failure; and shall provide to Seller the opportunity to inspect such Products as installed, if possible. The notice must be received by Seller during the Warranty Period for such product, unless otherwise directed in writing by the Seller. Within thirty (30) days after submitting such notice, Buyer shall package the allegedly defective Product in its original shipping carton(s) or a functional equivalent and shall ship to Seller at Buyer's expense and risk.

Within a reasonable time after receipt of the allegedly defective Product and verification by Seller that the Product fails to meet the warranty set forth above, Seller shall correct such failure by, at Seller's options, either (i) modifying or repairing the Product or (ii) replacing the Product. Such modification, repair, or replacement and the return shipment of the Product with minimum insurance to Buyer shall be at Seller's expense. Buyer shall bear the risk of loss or damage in transit, and may insure the Product. Buyer shall reimburse Seller for transportation cost incurred for Product returned but not found by Seller to be defective. Modification or repair, of Products may, at Seller's option, take place either at Seller's facilities or at Buyer's premises. If Seller is unable to modify, repair, or replace a Product to conform to the warranty set forth above, then Seller shall, at Seller's option, either refund



to Buyer or credit to Buyer's account the purchase price of the Product less depreciation calculated on a straight-line basis over Seller's stated Warranty Period.

THESE REMEDIES SHALL BE THE BUYER'S EXCLUSIVE REMEDIES FOR BREACH OF WARRANTY. EXCEPT FOR THE EXPRESS WARRANTY SET FORTH ABOVE, SELLER GRANTS NO OTHER WARRANTIES, EXPRESS OR IMPLIED BY STATUTE OR OTHERWISE, REGARDING THE PRODUCTS, THEIR FITNESS FOR ANY PURPOSE, THEIR QUALITY, THEIR MERCHANTABILITY, THEIR NONINFRINGEMENT, OR OTHERWISE. NO EMPLOYEE OF SELLER OR ANY OTHER PARTY IS AUTHORIZED TO MAKE ANY WARRANTY FOR THE GOODS OTHER THAN THE WARRANTY SET FORTH HEREIN. SELLER'S LIABILITY UNDER THE WARRANTY SHALL BE LIMITED TO A REFUND OF THE PURCHASE PRICE OF THE PRODUCT. IN NO EVENT SHALL SELLER BE LIABLE FOR THE COST OF PROCUREMENT OR INSTALLATION OF SUBSTITUTE GOODS BY BUYER OR FOR ANY SPECIAL, CONSEQUENTIAL, INDIRECT, OR INCIDENTAL DAMAGES.

Buyer assumes the risk and agrees to indemnify Seller against and hold Seller harmless from all liability relating to (i) assessing the suitability for Buyer's intended use of the Products and of any system design or drawing and (ii) determining the compliance of Buyer's use of the Products with applicable laws, regulations, codes, and standards. Buyer retains and accepts full responsibility for all warranty and other claims relating to or arising from Buyer's products, which include or incorporate Products or components manufactured or supplied by Seller. Buyer is solely responsible for any and all representations and warranties regarding the Products made or authorized by Buyer. Buyer will indemnify Seller and hold Seller harmless from any liability, claims, loss, cost, or expenses (including reasonable attorney's fees) attributable to Buyer's products or representations or warranties concerning same.

# www.elotouch.com

---

## Get the latest...

- **Product information**
  - **Specifications**
  - **News on upcoming events**
  - **Press release**
  - **Software drivers**
  - **Touch Monitor Newsletter**
- 

## Getting in Touch with Elo

To find out more about Elo's extensive range of touch solutions, visit our Website at [www.elotouch.com](http://www.elotouch.com) or simply call the office nearest you:

### North America

Elo TouchSystems  
301 Constitution Drive  
Menlo Park, CA 94025  
USA

(800) ELO-TOUCH  
(800) 356-8682  
Tel 650-361-4800  
Fax 650-361-4747  
[eloinfo@elotouch.com](mailto:eloinfo@elotouch.com)

### Germany

Tyco Electronics Raychem GmbH Tyco Electronics Raychem N.V.  
(Elo TouchSystems Division) (Elo TouchSystems Division)  
Finsinger Feld 1 Diestsesteenweg 692  
D-85521 Ottobrunn B-3010 Kessel-Lo  
Germany Belgium

Tel +49 (0)(89) 60822-0  
Fax +49(0)(89) 60822-180  
[elosales@elotouch.com](mailto:elosales@elotouch.com)

### Belgium

Tyco Electronics Raychem N.V. Tyco Electronics Raychem N.V.  
(Elo TouchSystems Division) (Elo TouchSystems Division)  
Diestsesteenweg 692  
B-3010 Kessel-Lo  
Belgium

Tel +32(0)(16)35 21 00  
Fax +32(0)(16)35 21 01  
[elosales@elotouch.com](mailto:elosales@elotouch.com)

### Asia-Pacific

Sun Hamada Bldg. 2F  
1-19-20 ShinYokohama  
Kanagawa 222-0033  
Japan

Tel +81(45)478-2161  
Fax +81(45)478-2180  
[www.tps.co.jp](http://www.tps.co.jp)

© 2008 Tyco Electronics Printed in USA



Our commitment. Your advantage.