

TASCAM®

DIGITAL PORTASTUDIO III 788

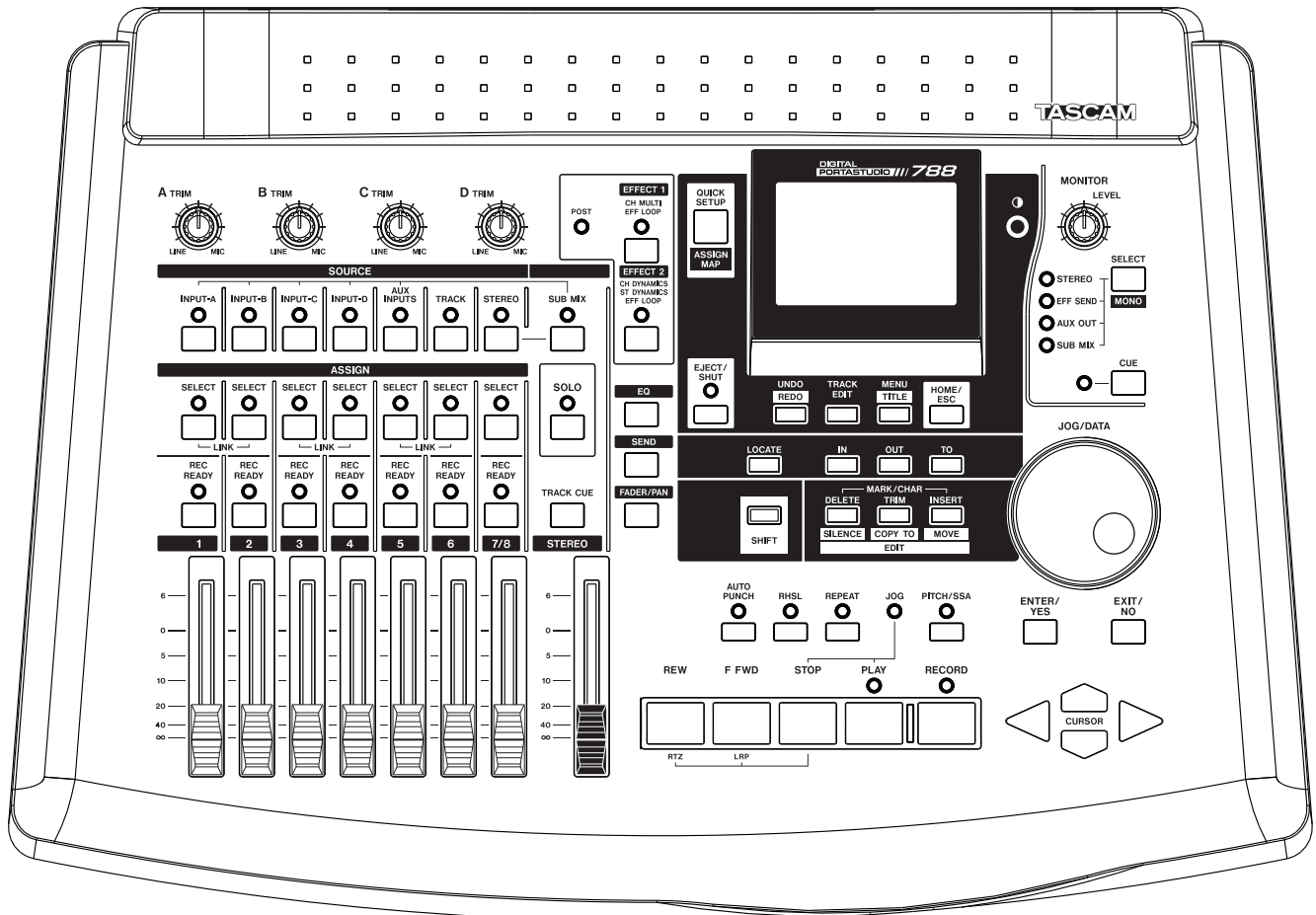
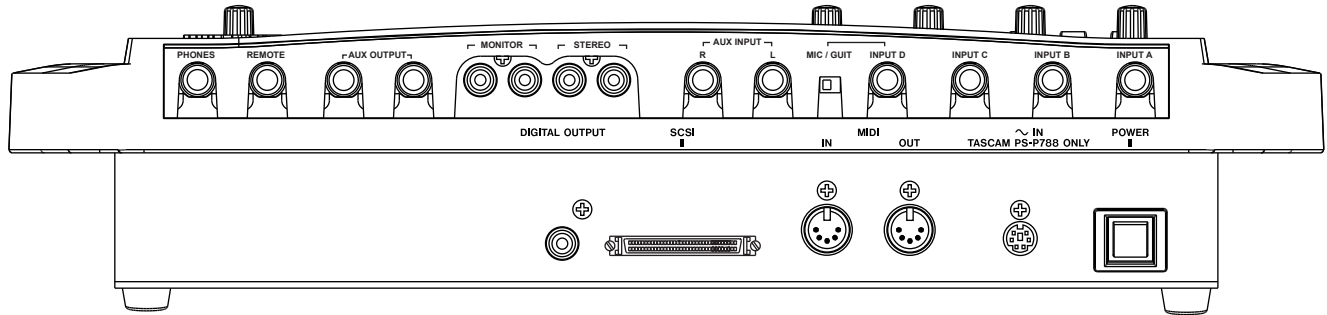

Edition Date: 7/10/2002
© 2002 TEAC/TASCAM, All Rights Reserved

VERSION 2.0 ADDENDUM

*This page
intentionally
left blank.*

Table of Contents

PREFACE

At TASCAM, we have been quite pleased with the success of the 788 Digital Portastudio. This product has brought a number of innovations at TASCAM, internally and externally.

The online forums at www.tascambbs.com are a good example. This forum has brought us closer to our customers, and our customers closer to each other. Most of the enhancements in v2.0 were pulled directly from user requests in the forums.

We hope you find the enhancements in v2.0 to be helpful in your use of the recorder. Thank you for continued support of TASCAM.

I) WAV File Import/Export Function	4
About WAV Files (16/24 bit, mono files)	4
About ISO-9660 (Level 1, "8.3" naming)	4
WAV File Export	4
WAV Export Troubleshooting	5
WAV File Import	5
WAV Import Troubleshooting	5
II) Improved Hard Drive Capabilities	6
Overview	6
About Partitions	6
A Note About Hard Drive Sizes	6
Reformat Partition	6
III) Other Enhancements	7
Time Remaining Display	7
Clone Master Track	7
CD-RW Erase	7
Burning Multiple CDs	7
Shortcut - Center Pan	7
Shortcut - Clear Meters	7
Current Song Display	7

Section I

WAV File Import/Export Functions

OVERVIEW

The 788 can utilize the WAV file format to bring sound files in and out of a song. The files will be written to and read from a Level 1 ISO-9660 formatted CD-ROM, using one of the approved CD recorders for the 788.

About WAV Files - (16 or 24 bit, mono files)

All files exported and imported must be created with a sample rate of 44.1kHz, since that is the native operating sample rate of the 788. Also, the files should be mono WAV files. Stereo WAV files cannot be imported.

	Import 16 bit WAV	Import 24 bit WAV
16 bit song on 788	YES	YES
24 bit song on 788	YES	YES

The WAV Import function imports 16 or 24 bit files into either 16 or 24 bit song files. The imported files will be written to match the bit depth of the song file.

	Export 16 bit WAV	Export 24 bit WAV
16 bit song on 788	YES	NO
24 bit song on 788	YES	YES

The WAV Export function exports 16 bit WAV files from 16 bit song files. When working with 24 bit songs, the files can be exported as 24 bit or 16 bit. The 16 bit export is helpful, since most other all-in-one studios cannot accept 24 bit files. Likewise, older DAWs may not accept 24 bit files.

About ISO-9660 Format - (level 1, 8.3 naming)

The CD format for importing and exporting WAV files is ISO-9660, Level 1. This format was chosen to provide maximum compatibility across dedicated hard disk recorders and Macintosh/Windows DAWs.

ISO-9660 was originally designed as the DOS CD-ROM format. As such, it follows the DOS "eight-dot-three" naming format. This uses 8 characters, followed by a

period, followed by the extension. So, valid file names will be something like KICKDRUM.WAV.

On export, the 788 will assign file names for you automatically. The names will be generic like TRACK001.WAV, TRACK002.WAV, and so on. On import, the 788 will assign the WAV file name to the virtual track to make it easier to find.

If you burn a disc from a computer to be imported into the 788, be sure to select the ISO-9660 Level 1 format. The more current Windows formats are also considered to be ISO-9660. Sometimes programs will designate "Level 1" ISO-9660 as "DOS", and more current formats as "Windows 95" or "Joliet". Check your computer's CD authoring software for more information on this.

Lastly, when burning a CD with WAV files for the 788 to import, be sure to place all the WAV files in the root directory of the CD. Do not place the files inside folders; the 788 will not read below the root directory.

WAV File Export

- 1) Place a blank disc in the CD recording drive.
- 2) Press MENU.
- 3) Select CD-R, and press ENTER.
- 4) Select WAV EXPORT, and press ENTER. The 788 will display all Virtual Tracks in this song file that contain audio.



NOTE: Track names cannot be edited in this step.

- 5) Select the virtual tracks to be exported. The JOG/DATA wheel and CURSOR highlight different tracks. The INSERT button will place a check mark by the track name, indicating it will be exported. The DELETE key will remove check marks from the highlighted tracks. When all tracks have been selected, press ENTER.

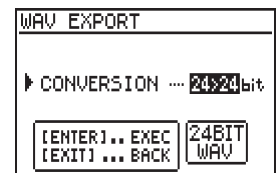

- 6) Select Resolution of file to be exported, and press ENTER. *NOTE: If the song on the 788 is recorded at 16 bit, WAV export is only available at 16 bit.*
- 7) The 788 will verify that you are ready to burn the WAV files to CD. Press ENTER again to confirm.
- 8) When the disc is complete, the 788 will ask if you would like another copy of the disc. Press YES or NO.

WAV File Import/Export Functions (Continued)**Section I****WAV Export Troubleshooting**

When exporting files to CDs, there are a few limitations on how much data can be moved at a time. (For instance, all of the selected WAV files must be able to fit on a single CD.) These messages may appear if you exceed one of the limitations.

"SELECTION EXCEEDS CD CAPACITY"

This indicates that you've selected more data than a CD can hold. You'll have to export a few tracks to one CD, and the rest of the tracks to another.

"TOO MANY TRACKS"

The 788 can only export up to 99 tracks at a time. If you run into this limitation, simply export 99 tracks on the first CD, then export the rest on a second pass.

"NO SPACE ON DISK FOR IMAGE FILE"

Before burning the data to CD, the 788 temporarily assembles all of the data on the hard drive. This message indicates that there is not enough space on the drive to create that working copy.

If you run into this problem, you need to generate some free space on the drive to enable the function to continue. Here are three simple ways to do it:

- 1) Erase Unwanted Songs - If you've got some old songs hanging around your drive that either you don't want, or you have backed up somewhere, delete them. That's the easiest way to free up space.
- 2) Use DELETE UNUSED - This function gets rid of data that is not being used in a song without destroying the song itself. It may free up enough space on the drive to allow the WAV file image to be generated. See p30 of the 788 Owner's Manual for more information.
- 3) Add More Space - You can add an external drive to the SCSI port on the 788 to give you more space. If you format the external drive to the 788 format, the 788 can use the space on the added hard drive for assembling the CD data.

WAV File Import

- 1) Place the CD-ROM with the WAV files in the CD recorder drive.
- 2) Press MENU.
- 3) Select CD-R, and press ENTER.
- 4) Select WAV IMPORT, and press ENTER. The 788 will display all WAV files on the CD-ROM.



- 5) Select a WAV file to import by highlighting the file, and pressing enter. (The 788 can only import one WAV file at a time.)

- 6) The 788 will show you a list of virtual tracks in the 788. Choose the virtual track that you want the WAV file to load into and press ENTER. (The 788 will only display empty virtual tracks, to prevent you from overwriting existing tracks.)

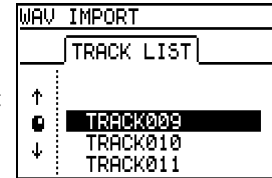

- 7) After the 788 loads the track, it will ask you if you have any other tracks you wish to load at this time. Press ENTER/YES or EXIT/NO.

When the WAV files are loaded into virtual tracks, the name of the WAV file is assigned to the virtual track. So, if you load KICKDRUM.WAV into a virtual track, that virtual track is now named KICKDRUM.WAV. This makes it easier to find those files once you've imported them.

WAV IMPORT TROUBLESHOOTING

If the 788 does not see WAV files on the CD-ROM, there are a few CD formatting issues to check. Try placing the CD-ROM in a computer, and look for these signs:

- 1) Make sure the CD-ROM is formatted as ISO-9660, Level 1. - If the CD Authoring program you used (like EZ CD Creator, Toast, or Nero) allowed for file names that exceed the "eight-dot-three" file naming scheme, then you don't have the appropriate format. (See the "About ISO-9660" section on the previous page.)

If the names do follow the Level 1 requirement, it is still possible that the names are the appropriate length, but the CD is the wrong CD format.

To solve this problem, simply burn the WAV files to CD again, with the CD set to ISO-9660 Level 1 format. Rename files as needed to fit the naming scheme.

- 2) Make sure the WAV files are in the root directory of the CD. If you open the disc on the computer, all of the files should be immediately apparent. You should not have to open any folders inside the disc. If the WAV files are in subdirectories, simply burn the disc again with the WAV files in the root directory.
- 3) Make sure the WAV files are mono files, at 44.1kHz, either 16 or 24 bit. The 788 cannot import stereo WAV files. Stereo sources should be imported as two mono WAV files - one each for the left and right side.
- 4) Make sure the files have the ".WAV" extension. The 788 may not recognize the files otherwise.

Section II

Improved Hard Drive Capabilities

OVERVIEW

Before v2.0, the 788 could identify and use up to 16GB from a single hard drive. v2.0 increases the usable area to 64GB of space. Be aware that this does not magically increase the size of your hard drive, it merely increases the amount of space that the 788 can recognize. You'll have to obtain a larger drive (either internal or external) to take advantage of this.

Keep in mind that the maximum capacity of a song is 7GB. This provides almost 1 hour and 45 minutes of all 8 tracks at 24 bit. If you need more time, you may need to break the recording into a few song files.

About Partitions

Whenever a system is writing to a hard drive, the data on the hard drive has to be stored at an "address". As hard drives get bigger and bigger, more and more addresses are needed. Eventually, you'll end up in a situation where the system cannot provide any more addresses, and the extra space cannot be used.

The computer industry ran into this problem in the mid-90's. To get around it, they allowed the drive to have multiple "partitions". Essentially, they broke the hard drive capacity into smaller, manageable pieces. To the system, each partition appears to be a different hard drive. In reality, they can all be from the same drive.

Before v2.0, the 788 could use up to 4GB in a partition, and allowed up to 4 partitions per drive. This allowed for a total of 16GB of space on the drive. With v2.0, the *partition* size is stepped up to 16GB. Since you can still have 4 partitions, that offers a total of 64GB of space.

A Note About Hard Drive Sizes:

If you replace your internal hard drive with a larger drive, or connect an external drive, you may notice that a drive will not yield all of the space that a drive quotes. For instance, a 60GB drive may only give you 56GB of space once mounted on the system.

There are two main reasons for this:

- 1 - Drive manufacturers will typically advertise "unformatted" capacity. Some space is used just in formatting the disk.
- 2 - Most drive sizes are quoted with rounded figures. In the chart at right, you can see that each step up in measurement actually occurs in steps of 1024. However, the quoted size will round to even thousands. This minor difference adds up to about a 7% variance between the drive's quoted size and its actual capacity.

RE-FORMAT (PARTITION)

Occasional formatting of the hard drive is generally considered to be "good housekeeping" on any system. Since the 788 can now hold such huge amounts of data, our engineers felt it may be cumbersome to back up everything, then format the whole drive, then restore all the data again.

To make this easier, they decided to offer the ability to format just one partition. It's kind of like giving you the ability to clean one room of a house at a time, rather than cleaning the whole house at once.

So, if you want to reformat partition 2, you can just copy the data you want to partition 1, then format only partition 2. Very simple!

Please keep in mind the difference between the FORMAT and RE-FORMAT commands. FORMAT clears out the whole drive. This is still needed if you choose to change the partition size, or if you want to wipe the entire drive clean. RE-FORMAT only formats one partition.

Step By Step Partition Formatting

- 1) Press MENU.
- 2) Select DISK, and press ENTER.
- 3) Select RE-FORMAT and press ENTER. The 788 will display each of the partitions that are currently available.
- 4) Highlight the partition you wish to format, and press ENTER.
- 5) The 788 will verify that you want to reformat the partition. Press ENTER again to confirm.

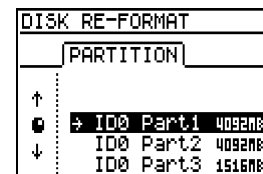

Rounded Hard Drive Size (Quoted Drive Sizes)	Real Hard Drive Size (Actual Storage Capacity)
1000 bytes = 1 KB (kilobyte)	1024 bytes = 1 KB (kilobyte)
1000 KB = 1 MB (megabyte)	1024 KB = 1 MB (megabyte)
1000 MB = 1 GB (gigabyte)	1024 MB = 1 GB (gigabyte)

1 GB = 1,000,000,000 Bytes 1 GB = 1,073,741,824 Bytes
 = 7% Difference

Section III Other v2.0 Enhancements

TIME REMAINING DISPLAY

v2.0 adds a display in the lower left hand corner of the home screen, telling you how much recording capacity you have available in this song. It accounts for:

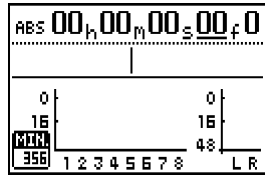

- 1) Free space available in the current drive partition or song file capacity, whichever is smaller. (Remember, a song file cannot exceed 7GB.)
- 2) Number of tracks armed for record - If no tracks are armed, it calculates space for one track. This is very helpful on large projects or live recordings.

CLONE MASTER TRACK

The MASTER TRACK is the track used for the stereo mixdown of the song when in PREMASTERING mode. (For an explanation of how PREMASTERING works, see the 788 Owner's Manual, p73-75.)

Before v2.0, the MASTER TRACK could only be used for your final mix. It could not be brought back into your song for more processing.

With v2.0, you can now copy the audio on the MASTER TRACK onto regular tracks. This allows you to use the MASTER TRACK for bouncing all 8 tracks in a pass, or simply touch up the mix with a little EQ or dynamics.

To copy the data from the Master Track:

- 1) Press TRACK EDIT.
- 2) Select CLONE TRACK.
- 3) Turn Src.Trk all the way to the right, until it says MST.
- 4) Select the Destination tracks in Dst.Trk and press ENTER.



CD-RW ERASE

The 788 previously did not have a method to merely erase a CD-RW disc. Erasing the disc is not necessary for data back-ups, since that function will overwrite the previous data. However, the Audio CD burning process needs to start from a blank disc. The CD-RW ERASE function (accessed in the CD-R menu) will give you the ability to erase a disc for reuse as an audio CD, or for any other reason.

This function will only work with the approved CD-RW drives... the CD-R only drives can't use CD-RW media.

BURNING MULTIPLE CDs

When you burn an audio CD, you have to select all the songs, the space between the songs, and so on. Then, the 788 will create a disc image. After that, the 788 burns the disc. If you wanted multiple copies, you had to go through the whole authoring process for each copy of the disc.

With v2.0, when the 788 finishes burning a CD, the 788 will prompt you to burn another copy.

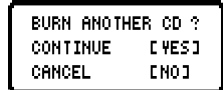

If you place a new disc in the tray and select "YES", the 788 will use the same disc image to burn another copy. You won't have to design the whole CD again, or wait for the 788 to generate another disc image. This is a tremendous time saver.

SHORTCUT - CENTER PAN

To save "tweaking" time, we have added a shortcut for centering the PAN controls on the mixer channels. Pressing SHIFT + FADER/PAN will center the pan on the current mixer channel. (This only works in the main mixer, not the TRACK CUE or INPUT SUBMIX.)

If two channels are linked, both channels will have the pan controls centered.

SHORTCUT - CLEAR METERS

The meters on the 788 can be set to maintain the peak level of a track. This is useful during recording, since you'll know if the track overloaded, or if the levels were too low. To set the meters to keep the peak level:

- 1) Press MENU.
- 2) Select OPTION.
- 3) Select GLOBAL.
- 4) Set PEAK HOLD to KEEP and press ENTER.

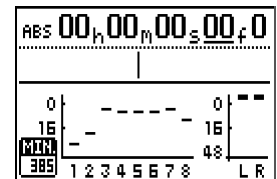

Before v2.0, the only way to clear the meters was to go back to this menu, set PEAK HOLD to something other than KEEP, and then switch it back. Now with v2.0, you can clear the meters by simply pressing SHIFT + EXIT/NO.

CURRENT SONG DISPLAY

By pressing SHIFT + HOME/ESC, you can see vital information on the current song. This includes the song name, bit depth, free space in the current partition and remaining song memory.



TASCAM®

DIGITAL PORTASTUDIO III 788

VERSION 2.0 ADDENDUM

TEAC CORPORATION Phone: (0422) 52-5082	3-7-3, Nakacho, Musashino-shi, Tokyo 180-8550, Japan
TEAC AMERICA, INC. Phone: (323) 726-0303	7733 Telegraph Road, Montebello, California 90640
TEAC CANADA LTD. Phone: 905-890-8008 Facsimilie: 905-890-9888	5939 Wallace Street, Mississauga, Ontario L4Z 1Z8, Canada
TEAC MEXICO, S.A. De C.V. Phone: 5-658-1943	Privada De Corina, No.18, Colonia Del Carmen Coyoacan, Mexico DF 04100
TEAC UK LIMITED Phone: 01923-819699	5 Marlin House, Marlin Meadow, The Croxley Centre, Watford, Herts. WD1 8YA, U.K.
TEAC DEUTSCHLAND GmbH Phone: 0611-71580	Bahnstrasse 12, 65205 Wiesbaden-Erbenheim, Germany
TEAC FRANCE S. A. Phone: 01.42.37.01.02	17 Rue Alesis-de-Tocqueville, CE 005 92182 Antony Cedex, France
TEAC BELGIUM NV/SA Phone: 0162-510860	Oeverkruid 15, NL-4941 VV Raamsdonksveer, Netherlands
TEAC NEDERLAND BV Phone: 0162-510210	Oeverkruid 15, NL-4941 VV Raamsdonksveer, Netherlands
TEAC AUSTRALIA PTY.,LTD. A.C.N. 005 408 462 Phone: (03) 9644-2442	106 Bay Street, Port Melbourne, Victoria 3207, Australia
TEAC ITALIANA S.p.A. Phone: 02-66010500	Via C. Cantù 11, 20092 Cinisello Balsamo, Milano, Italy
