

INSTRUCTION MANUAL

***MODEL 460H NEMA
OZONE MONITOR***

© Teledyne Instruments
Advanced Pollution Instrumentation Division
(T-API)
6565 Nancy Ridge Drive
San Diego, CA 92121-2251

TOLL-FREE: 800-324-5190
TEL: 858-657-9800
FAX: 858-657-9816
EMAIL: api-sales@teledyne.com
WEB SITE: www.teledyne-api.com

03662
Rev. D
1/8/04

SAFETY MESSAGES

Your safety and the safety of others is very important. We have provided many important safety messages in this manual. Please read these messages carefully.

A safety message alerts you to potential hazards that could hurt you or others. Each safety message is associated with a safety alert symbol. These symbols are found in the manual and inside the instrument. The definition of these symbols is described below:



General Warning/ Caution: Refer to the instructions for details on the specific danger.



Caution: Hot Surface



Caution: Electrical Shock Hazard



Technician Symbol: All operations marked with this symbol are to be performed by qualified maintenance personnel only.



CAUTION

The monitor should only be used for the purpose and in the manner described in this manual.

If you use the monitor in a manner other than that for which it was intended, unpredictable behavior could ensue with possibly hazardous consequences.

TABLE OF CONTENTS

SAFETY MESSAGES.....	II
TABLE OF CONTENTS	III
FIGURES	V
TABLES.....	VI
I. 0 INTRODUCTION	7
1. 1 PREFACE.....	7
1.2 WARRANTY POLICY	8
1.3 PRINCIPLE OF OPERATION	9
1.4 SPECIFICATIONS	10
2.0 INSTALLATION	11
2.1 MECHANICAL INSTALLATION	11
2.2 PNEUMATIC CONNECTIONS	12
2.3 AC POWER CONNECTION	13
2.4 ELECTRICAL I/O CONNECTIONS	14
2.4.1 Analog Output	14
2.4.2 Digital Status Outputs	15
2.4.3 Control Inputs	16
2.4.4 RS232/RS485 Serial Communications Port	17
3.0 STARTUP	18
4.0 OPERATION.....	19
4.1 FRONT PANEL DISPLAY	19
4.1.1 O ₃ readout.....	19
4.1.2 Pressure Display	19
4.1.3 Zero Calibration.....	19
4.1.4 Status LED's.....	19
4.2 AUTO-ZERO OPERATION (OPTIONAL)	20
4.2.1 Auto-Zero Installation	20
4.2.2 Auto-Zero Function	20
4.2.3 Auto Zero Error.....	20
5.0 SERIAL COMMUNICATIONS.....	21
5.1 SERIAL PORT CONFIGURATION.....	21
5.2 COMMAND SYNTAX	21
5.3 COMMAND SUMMARY	22
5.4 COMMAND REFERENCE	23
5.4.1 CAUTO.....	23
5.4.2 CZERO	24
5.4.3 DACSTEP.....	25
5.4.4 O ₃	26
5.4.5 SETADDR.....	27
5.4.6 TDUMP	28
5.4.7 TLIST.....	29
5.4.8 VGET.....	30
5.4.9 VLIST.....	31
5.4.10 VSET.....	32
6.0 MAINTENANCE	33
6.1 REPLACING THE GAS FILTER ELEMENT (OPTIONAL).....	33

6.2 CLEANING EXTERIOR SURFACES OF THE M460H	33
6.3 DEGREE OF PROTECTION	33
7.0 SENSOR AND SYSTEM TROUBLESHOOTING	34
7.1 STATUS OUTPUT SUMMARY	34
7.2 SENSOR OK	34
7.3 INVALID READING	35
7.4 LAMP LOW	35
7.5 CELL DIRTY	35
7.6 STATUS OUTPUT SUMMARY TABLE	36
APPENDIX A – SERIAL PORT CONFIGURATION	37

FIGURES

Figure 2-1 Mounting Hole Locations.....	11
Figure 2-2 Pneumatic Connections.....	12
Figure 2-3 Electrical Connections.....	14
Figure 2-4 Digital Output Connections.....	15
Figure 2-5 Typical RS232 and RS485 Connections.....	17
Figure A-1 RS232/RS485 Jumpers (Controller PCA#03492).....	37

TABLES

Table 2-1 Digital Status Output Pins	15
Table 2-2 Control Inputs.....	16
Table 2-3 Serial Port Pins	17
Table 4-1 Auto-Zero Function.....	20
Table 5-1 Serial Port Configuration	21
Table 5-2 Serial Port Command Summary.....	22
Table 7-1 Digital Status Outputs.....	34
Table 7-2 Status Output Truth Table.....	36

I.0 INTRODUCTION

1.1 Preface

Teledyne API is pleased that you have purchased the Model 460H NEMA. Included is a full one-year warranty (see Section 1.2) and we at Teledyne API will be pleased to provide you with any support required so that you may utilize our equipment to the fullest extent.

The Model 460H is a microprocessor based high concentration ozone monitor for monitoring process streams in water treatment, food processing, and research applications. The Model 460H has been designed to give accurate and stable readings over long time periods with little or no maintenance or calibration.

The flexibility of the software as well as the analog and digital I/O allow the Model 460H to interface with a broad range of devices for process control and data logging.

We hope you will not experience any problems with the Teledyne API Model 460H but if you do, our full time customer service department is always available to answer your questions.

1.2 WARRANTY POLICY

ADVANCED POLLUTION INSTRUMENTATION DIVISION

02024c

Prior to shipment, Teledyne API equipment is thoroughly inspected and tested. Should equipment failure occur, Teledyne API assures its customers that prompt service and support will be available.

COVERAGE

After the warranty period and throughout the equipment lifetime, Teledyne API stands ready to provide on-site or in-plant service at reasonable rates similar to those of other manufacturers in the industry. All maintenance and the first level of field troubleshooting are to be performed by the customer.

NON- TELEDYNE API MANUFACTURED EQUIPMENT

Equipment provided but not manufactured by Teledyne API is warranted and will be repaired to the extent and according to the current terms and conditions of the respective equipment manufacturers warranty.

GENERAL

Teledyne API warrants each Product manufactured by Teledyne API to be free from defects in material and workmanship under normal use and service for a period of one year from the date of delivery. All replacement parts and repairs are warranted for 90 days after the purchase.

If a Product fails to conform to its specifications within the warranty period, Teledyne API shall correct such defect by, in Teledyne API's discretion, repairing or replacing such defective Product or refunding the purchase price of such Product.

The warranties set forth in this section shall be of no force or effect with respect to any Product:

(i) that has been altered or subjected to misuse, negligence or accident, or (ii) that has been used in any manner other than in accordance with the instruction provided by Teledyne API or (iii) not properly maintained.

THE WARRANTIES SET FORTH IN THIS SECTION AND THE REMEDIES THEREFORE ARE EXCLUSIVE AND IN LIEU OF ANY IMPLIED WARRANTIES OF MERCHANTABILITY, FITNESS FOR PARTICULAR PURPOSE OR OTHER WARRANTY OF QUALITY, WHETHER EXPRESSED OR IMPLIED. THE REMEDIES SET FORTH IN THIS SECTION ARE THE EXCLUSIVE REMEDIES FOR BREACH OF ANY WARRANTY CONTAINED HEREIN. TELEDYNE API SHALL NOT BE LIABLE FOR ANY INCIDENTAL OR CONSEQUENTIAL DAMAGES ARISING OUT OF OR RELATED TO THIS AGREEMENT OF TELEDYNE API'S PERFORMANCE HEREUNDER, WHETHER FOR BREACH OF WARRANTY OR OTHERWISE.

TERMS AND CONDITIONS

All units or components returned to API should be properly packed for handling and returned freight prepaid to the nearest designated Service Center. After the repair, the equipment will be returned, freight prepaid.

1.3 Principle of Operation

The detection of ozone molecules is based on absorption of 254 nm UV light due to an internal electronic resonance of the O₃ molecule. The Model 460H uses a mercury lamp constructed so that a large majority of the light emitted is at the 254nm wavelength. Light from the lamp shines through an absorption cell through which the sample gas being measured is passed. The ratio of the intensity of light passing through the gas to a reference measurement which does not pass through the gas forms the ratio I/I₀. This ratio forms the basis for the calculation of the ozone concentration.

The Beer-Lambert equation, shown below, calculates the concentration of ozone from the ratio of light intensities.

$$C_{O_3} = -\frac{10^6}{\alpha \times \ell} \times \frac{T}{273^\circ \text{K}} \times \frac{14.695 \text{psi}}{P} \times \ln \frac{I}{I_0}$$

Where:

- I = Intensity of light passed through the sample
- I₀ = Intensity of light through sample free of ozone
- α = absorption coefficient
- ℓ = path length
- C_{O₃} = concentration of ozone in parts per million
- T = sample temperature in degrees Kelvin
- P = pressure in pounds per square inch (absolute)

As can be seen the concentration of ozone depends on more than the intensity ratio. Temperature and pressure influence the density of the sample. The density of the gas changes the number of ozone molecules in the absorption cell which impacts the amount of light removed from the light beam. These effects are addressed by directly measuring temperature and pressure and including their actual values in the calculation. The absorption coefficient is a number that reflects the inherent ability of ozone to absorb 254 nm light. Most current measurements place this value at 308 cm⁻¹ atm⁻¹ at STP. The value of this number reflects the fact that ozone is a very efficient absorber of UV radiation which is why stratospheric ozone protects the life forms lower in the atmosphere from the harmful effects from solar UV radiation. Lastly, the absorption path length determines how many molecules are present in the column of gas in the absorption cell.

The intensity of light is converted into a voltage by the detector/preamp module. The voltage is converted into a number by a voltage-to-frequency (V/F) converter capable of 80,000 count resolution. The digitized signal, along with the other variables, are used by the CPU to compute the concentration using the above formula.

1.4 Specifications

Measurement Principle	UV Absorption (Beer Lambert Law)
Ranges	0-5%, 0-10%, 0-15% w/w, 0-20% w/w 0-100 g/Nm ³ , 0-200 g/Nm ³ , 0-300 g/Nm ³ , 0-400g/ Nm ³
Measurement Units	wt%, g/Nm ³
Accuracy	± 1% of Full Scale
Precision/Repeatability	±0.5% of Full Scale Range
Resolution	0.1 % w/w or .01 g/Nm ³
Response Time (95%)	<5 sec to 95%
Compensation	Pressure, Temperature (NTP = 273.15K, 760mmHg)
Gas Inlet Pressure Range	3.0 – 30.0 psig
Gas Flow Rate	0.2 – 2.0 LPM
Temperature Range	5-45°C
Dimensions (H x W x D)	12.64" x 11.19" x 6.08" (321mm x 284mm x 154mm)
Weight	9.40lb (4.27kg)
Power	110-240V~, 50/60Hz, 2.5A
Environmental Conditions	Installation Category (Overvoltage Category) II Pollution Degree 2
Maximum Operating Altitude	2000 meters
Analog Output Voltage	0-5V, 4-20mA (Optional)
Isolated Analog Output 4-20mA Mode*	Maximum voltage between outputs and ground 60V peak
Degree of Protection (IP Code)	IPX65

*Optional

2.0 Installation

Upon receiving the Model 460H please verify that there is no apparent shipping damage. (If damage has occurred please advise shipper first, then Teledyne API.)

2.1 Mechanical Installation

1. Mount the enclosure securely to a vertical surface. Figure 2-1 below shows the locations of the four mounting holes. All four mounting holes should be used to secure the monitor.

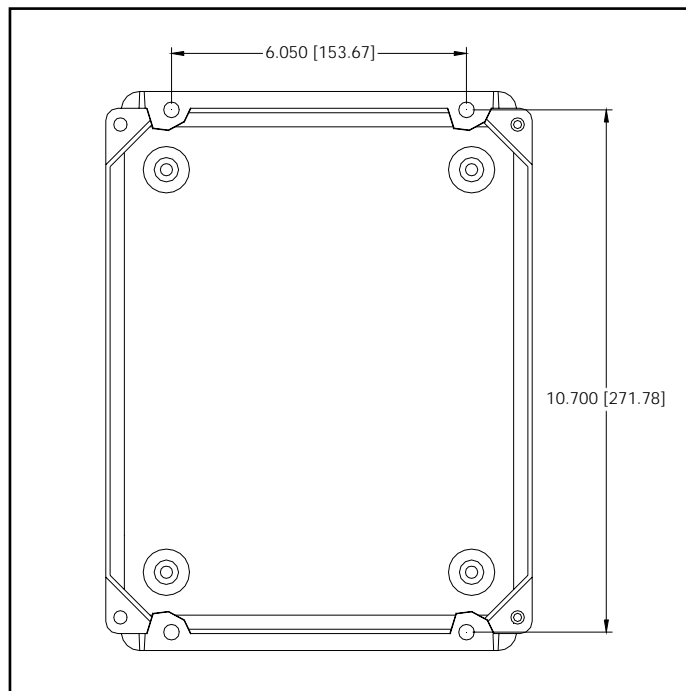

Figure 2-1 Mounting Hole Locations

2.2 Pneumatic Connections

1. Connect a ¼” exhaust line to the fitting labeled ‘Exhaust.’ This line should be vented to an outside area, since the exhaust gas may still contain trace levels of ozone that may not be completely removed by the built-in the ozone scrubber.



CAUTION

Exhaust gas from the M460H may contain dangerous levels of ozone!

2. Connect the ozone delivery line to the ¼” inlet fitting labeled “Ozone Inlet” on the bottom face of the enclosure (See Figure 2-2.) The ozone delivery should be regulated to no more than 30psig. All tubing used should be made of ozone resistant material such as PTFE(Teflon™) or FEP. API can supply appropriate tubing for connecting the ozone supply line.
3. Connect the oxygen or other zero gas source to the ¼” tube fitting labeled ‘Zero Gas Inlet.’ Zero Gas supply pressure should be regulated between 5 and 30 psig.
4. The gas flow rate through the monitor should be established between 0.5 and 2.0 L/min.

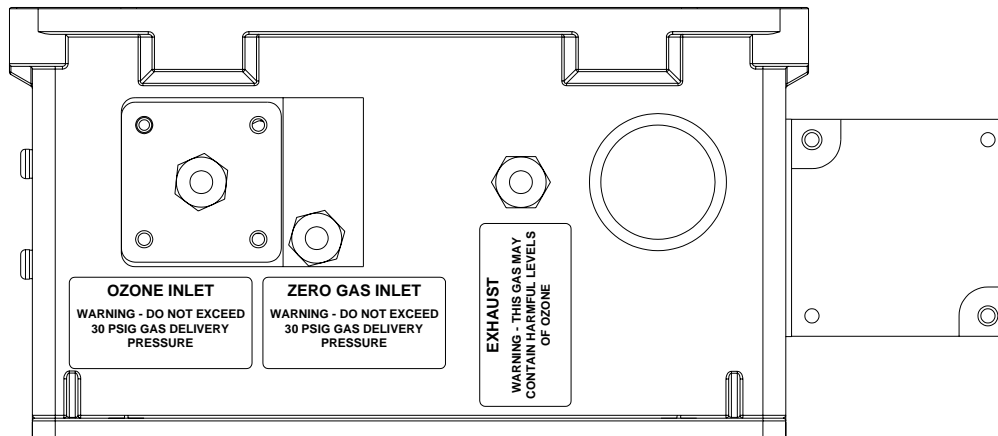

Figure 2-2 Pneumatic Connections

2.3AC Power Connection

Connect AC power to the instrument. A hole is provided on the bottom face of the enclosure for installing a ½” conduit fitting for routing the electrical wiring into the instrument. In order to maintain the IP (NEMA4X) rating of the enclosure, an appropriate sealed conduit connector should be used. Figure 2-3 below shows the location of the three terminal connector for the AC power. It is recommended that if multi-strand wires are used to make the AC connections, the wire ends should first be “tinned” with solder to ensure that the screw terminals can make a reliable connection to the wires.



CAUTION!

Disconnect power to the AC mains before making any electrical connections to the Model 460H.



IMPORTANT!

A proper earth ground connection must be made to the receptacle labeled “Earth Ground” on the 3 pin AC connector. Failure to do so may result in a shock hazard and malfunction of the instrument.

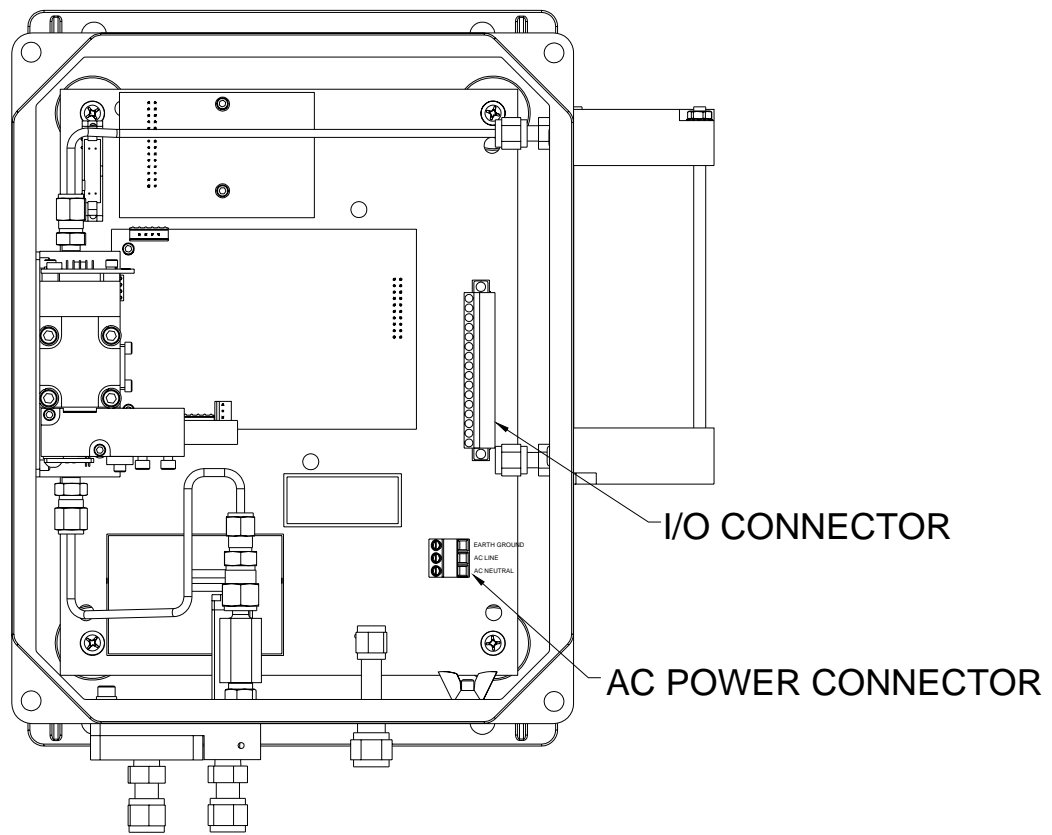

Figure 2-3 Electrical Connections

2.4 Electrical I/O Connections

All user I/O connections are available on the 16 pin connector on the mainboard (See Figure 2-3 for location.) This connector can be unplugged from the header on the mainboard for easier access when wiring. To disconnect from mainboard, loosen the two retaining screws at either end of the connector.

When connecting multi-strand wire to this connector, the wire ends should be “tinned” with solder to ensure a reliable connection. This is not necessary if solid-core wire is used.

2.4.1 Analog Output

The analog output is located on the two pins labeled ‘Analog Out +’ and ‘Analog Out –’. The analog output can be configured for voltage or current output. The standard output is a 0-5 volt output. The analog output can also be optionally configured for a 4-20mA Current output. Check the serial number tag on the instrument to determine Analog Output configuration.

2.4.2 Digital Status Outputs

The M460H has four digital status outputs for indicating error and operational status conditions. These outputs are in the form of opto-isolated open-collector transistors. They can be used to drive status LED's on a display panel or interface to a digital device such as a Programmable Logic Controller (PLC).

Figure 2-4 shows the most common way of connecting the digital outputs to an external device such as PLC. Note: Most devices, such as PLC's, have internal provision for limiting the current that the input will draw from an external device. When connecting to a unit that does not have this feature, external dropping resistors must be used to limit the current through the transistor output to 50mA or less.

See Chapter 7 for details on using the Status Outputs for diagnosing sensor and system-level malfunctions.

Table 2-1 below describes the function of the status outputs.

Table 2-1 Digital Status Output Pins

Label	Name	Operation
STATUS OUT 1	Sensor O.K.	Normally On
STATUS OUT 2	Invalid Reading	Normally Off
STATUS OUT 3	Lamp Low	Normally Off
STATUS OUT 4	Cell Dirty	Normally Off
STATUS OUT 5	Auto-Zero Error	Normally Off
STATUS OUT 6	Spare	Undefined
STATUS COM	Common Pin for all Status Outputs	N/A

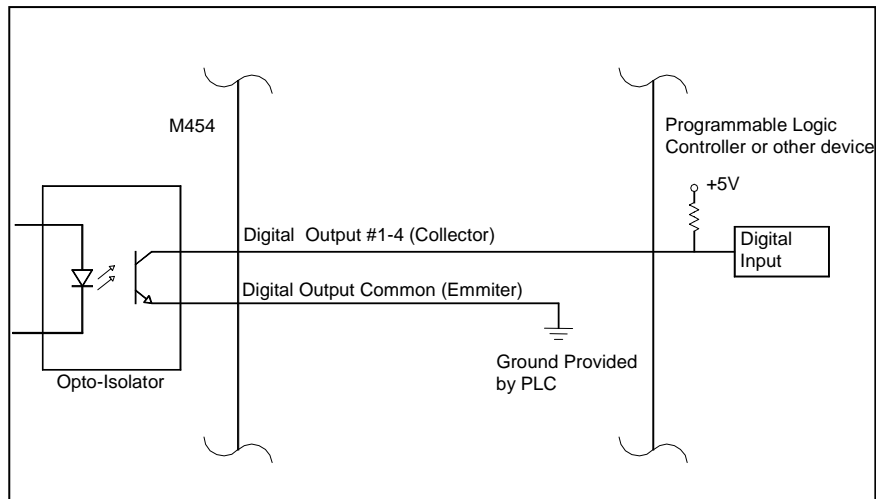

Figure 2-4 Digital Output Connections

2.4.3 Control Inputs

There are 2 digital control inputs on the I/O connector; they are labeled 'Zero Input' and 'Aux Input.' The control inputs are used for remote control of the M460H by a device such as a PLC. These inputs are triggered by providing a contact closure or low impedance current path between the Input and the Gnd pin. This can be done by using a mechanical switch or isolated transistor type output from another device, such as a PLC. Never connect a voltage level output from another device to these contacts. The functions of the control inputs is summarized below in Table 2-2:

Table 2-2 Control Inputs

Input	Description
Zero Input	Zero Calibration
Aux Input	Pressure Display

Zero Calibration Input:

The zero calibration input is used to initiate zero calibration from an external device. This input performs exactly the same function as the 'Zero' buttons on the front panel.

Pressure Display Input:

The pressure display input is used to display the pressure on the front panel. This input performs exactly the same function as the 'Pressure' buttons on the front panel.

2.4.4 RS232/RS485 Serial Communications Port

A bi-directional RS232/485 Serial Port Interface is provided that can be used for data acquisition and instrument control. All that is required to use this interface is a computer with a serial communications port (COM port) and terminal software. Three pins are provided on the I/O connector for serial communications as shown in Table 2-3.

Table 2-3 Serial Port Pins

Label	Description
SERIAL TX	Serial Transmit (RS485 – A)
SERIAL RX	Serial Receive (RS485 – B)
SERIAL GND	Serial Ground (RS232 Only)

The Serial Port can be configured for either RS232 or RS485. The standard factory configuration is RS232. For direct connection to a PC or Laptop, RS232 should be used. For a permanent connection into a data acquisition system, RS485 is recommended because it has better noise immunity and is more reliable when communicating over longer distances. See Appendix A for details on changing the Serial Port configuration.

Figure 2-5 below shows typical connections using RS232 and RS485. Note that the RS485 connection does not use the SERIAL GND pin.

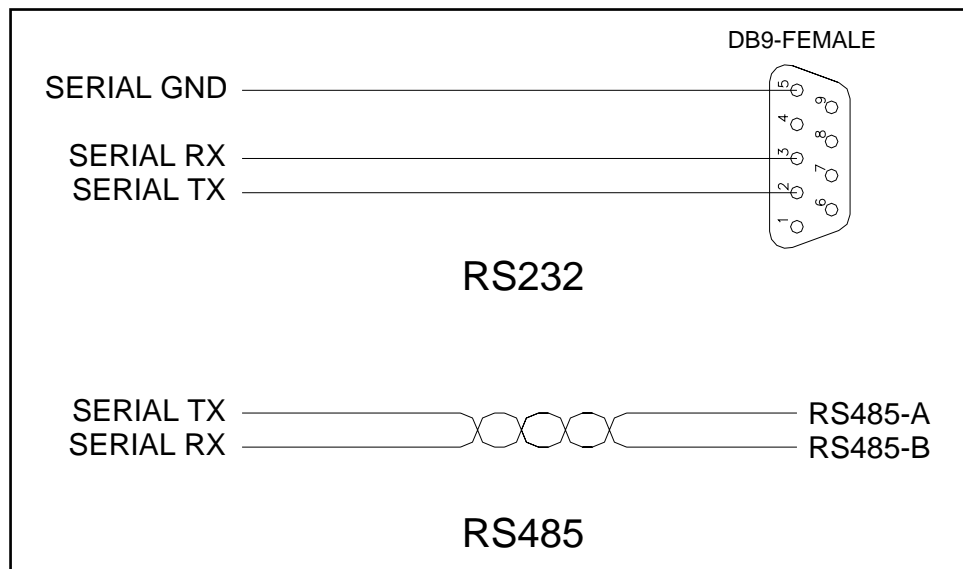

Figure 2-5 Typical RS232 and RS485 Connections

See Chapter 5 for information on the Serial Communications protocol used by the M460H.

3.0 Startup

Perform the following steps when first installing the M460H ozone monitor or when bringing the monitor back into service.

1. Turn on power to the monitor. The display will briefly display the “API” logo followed by the software version. The display will then begin showing ozone concentration.
2. Establish a flow of zero gas to the monitor. Zero gas can be oxygen or clean, dry air. If monitor cannot be disconnected from an ozone generator, then establish flow through the generator and monitor with the generator turned off. Flow rate through monitor should be between 0.5 – 2.0 LPM (Liters per minute.)
3. Let monitor warm up and purge for a minimum of 5 minutes. Zero the monitor by simultaneously pressing the Zero buttons on the front panel. The display should momentarily show dashes (‘----’) after which the display should go quickly to zero.
4. Check Status LED’s on front panel; Sensor OK led should be ON, all other LED’s should be OFF. If the Status LED’s are not in this state, refer to Chapter 7 for troubleshooting information.
5. Observe the monitor for several more minutes at zero to ensure that it is stable.
6. The monitor is now ready to measure ozone.

4.0 Operation

The M460H has been designed for simple and trouble-free operation. The Sections below detail the operational features of the M460H.

4.1 Front Panel Display

4.1.1 O₃ readout

The current ozone concentration is displayed in the 4 digit readout in the center of the display. The concentration is displayed in the currently selected units, either wt% or g/Nm³.

4.1.2 Pressure Display

The pressure inside the measurement cell can be displayed on the readout by pressing and holding the 'Pressure' key on the front panel. The pressure is displayed in units of psia (pounds per square inch absolute.) The normal ambient pressure at sea level is about 14.7psia. Ambient pressure at higher elevations will be somewhat less.

The M460H can accurately measure ozone at cell pressures of 12 - 20psia. Care should be taken in setting up the monitor to avoid over-pressurizing the cell, as this will result in erroneous readings.

4.1.3 Zero Calibration

A Zero Calibration can be performed on the monitor at any time by simultaneously pressing the two 'Zero' buttons on the front panel. The monitor will briefly display dashes ('----') after which the concentration should quickly go to zero.

The Zero Calibration is calculated based on the current measurement in the cell; so care must be taken to ensure that all ozone is purged from the cell before pressing the 'Zero' buttons.

If the Auto-Zero option is not used, API recommends performing a manual Zero Calibration on the monitor once a week.

4.1.4 Status LED's

The four status LED's to the right of the display indicate the general status of the Model 460H Monitor. During normal operation, after the monitor has warmed up, the green 'Sensor OK' LED should be on and all other Status LED's should be off. For information on troubleshooting using the Status LED's, see Chapter 7.

4.2 Auto-Zero Operation

The Auto-Zero feature allows the monitor to operate unattended for extended periods of time. This feature automatically performs a Zero Calibration at specific intervals (default interval is 12hrs.) The monitor does this by opening a solenoid valve to allow externally supplied Zero Gas to purge the monitor and then automatically performs a Zero Calibration.

4.2.1 Auto-Zero Installation

In order for this feature to function properly, external, pressurized zero gas must be supplied to the monitor as detailed in Section 2.2.

4.2.2 Auto-Zero Function

When the Auto-Zero function is triggered, the monitor performs the steps outlined in Table 4-1 below.

Table 4-1 Auto-Zero Function

Step	Function	Display Reads
1	Switch Auto-Zero valve on	N/A
2	Purge cell for 20 seconds	Holds and Flashes Concentration Value
3	Perform Zero Calibration	Dashes: '----'
4	Switch Auto-Zero valve off	Dashes: '----'
5	Hold-Off for 3 sec to return Measurement Gas to cell	Dashes: '----'
6	Return to Measurement Mode	Normal Concentration Display

4.2.3 Auto Zero Error

When performing an Auto-Zero Calibration, the monitor checks to make sure the ozone concentration is near zero before calibration. If the ozone concentration is above 0.5wt% or 5.0 g/Nm³, the monitor will not perform the calibration and will display a "ZERO ERR" message on the display. The monitor will also turn on the Auto-Zero Error status signal (See Section 2.4.2 Digital Status Outputs.) This Status Signal will remain on until another Auto-Zero Calibration is successfully performed or a Manual Zero Calibration is performed.

If an Auto-Zero error is detected, a manual Zero Calibration should be performed (See Section 4.1.3 Zero Calibration.)

5.0 Serial Communications

The M460H comes equipped with a powerful digital Serial Communications Port that can be used for Data Acquisition and for changing instrument configuration. This port can be configured for either RS232 or RS485(half-duplex) operation. See Section 2.4.4 for details on connecting the port to a computer or Data Acquisition system.

5.1 Serial Port Configuration

The Serial Port of the device being used to communicate with the M460H should be configured as follows:

Table 5-1 Serial Port Configuration

Parameter	Value
Baud Rate	9600 bps
Data Bits	8
Stop Bits	1
Parity	None

5.2 Command Syntax

All characters sent and received are standard Ascii characters and all numbers are decimal numbers converted to Ascii text.

All commands are sent using the following syntax:

<address><command>:<data1>,<data2>#<checksum><CR>

Where:

address is the instrument address(default =1)

command is the command string being sent

: (colon) is the data separator and is only included if data is being sent as part of the command (See Command Details below to see if a command requires data or not)

data1 is the first data parameter, if required.

data2 is the second data parameter, if required.

is the Checksum separator, sent only if optional checksum is included

checksum is an Ascii checksum of all characters up to the # character. The checksum is optional, commands sent without the checksum(and checksum separator,) are also valid.

CR is a carriage return, Ascii 13.

Examples of valid Commands with no data:

Checksum Included:
1O3#179<CR>
No Checksum:
1O3<CR>

Examples of valid Commands with data:

Checksum Included:
1VSET:1,20#620<CR>
No Checksum:
1VSET:1,20<CR>

5.3 Command Summary

Table 5-2 below lists the commands available and a summary of their function.

Table 5-2 Serial Port Command Summary

Command	Description
CAUTO	Perform an Auto-Zero Calibration (if option is installed)
CZERO	Perform a manual zero calibration (zero calibration is computed based on current O3 reading in cell)
DACSTEP	Analog Output Test Mode, Step Function
O3	Returns current O3 concentration
SETADDR	Set communications address
TDUMP	Returns a compact list of current measurement parameters
TLIST	Returns all current measurement parameters
VGET	Get Single VAR value
VLIST	Lists all internal VARS
VSET	Sets value of internal VAR

5.4 Command Reference

5.4.1 CAUTO

Syntax

<address>CAUTO<CR>

Description

Perform an Auto-Zero Calibration. Valid only if Auto-Zero option is installed in monitor.

Data Parameters Sent

None

Response

<address>:<success_flag>#<checksum><CR>

Example

Command:

1CAUTO<CR>

Response:

1:OK#261<CR> - Calibration Successful

1:FAIL#391<CR> - Calibration Failed

5.4.2 CZERO

Syntax

<address>CZERO<CR>

Description

Perform a Zero Calibration. Note that calibration is performed based on concentration currently in measurement cell. Instrument should be sufficiently purged with zero gas before issuing this command.

Data Parameters Sent

None

Response

<address>:<success_flag>#<checksum><CR>

Example

Command:
1CZERO<CR>

Response:
1:OK#261<CR> - Calibration Successful
1:FAIL#391<CR> - Calibration Failed

5.4.3 DACSTEP

Syntax

<address>DACSTEP<CR>

Description

Puts instrument in the Analog Output setup mode. The Analog Output steps from zero to full-scale in 20% increments, pausing for 4 seconds at each level. This repeats 5 times, after which the instrument returns to normal operation. This mode is useful for testing the Analog Output and the operation of any equipment measuring the Analog Output.

Data Parameters Sent

None

Response

<address>:<success_flag>#<checksum><CR>

Example

Command:

1DACSTEP<CR>

Response:

1:OK#261<CR> - Calibration Successful

1:FAIL#391<CR> - Calibration Failed

Notes

Note that the DACSTEP function takes some time to complete. When the command is sent to the monitor, it will immediately respond with the <address> and colon ':' as an acknowledgement that the message was received. After the function is complete the rest of the response will be sent. No additional commands should be issued to the monitor until the function completes.

5.4.4 O3

Syntax

<address>O3<CR>

Description

Returns the current ozone concentration measured by the monitor.

Data Parameters Sent

None

Response

<address>:<o3_conc>#<checksum><CR>

Example

Command:

1O3<CR>

Response:

1:12.01898#518<CR> - Current O3 Concentration (reading 12.02 wt%)

Notes

Note that the concentration value returned shows more digits after the decimal than the front panel display. Concentration values should only be considered valid to 4 significant digits.

5.4.5 SETADDR

Syntax

`<address>SETADDR:<new_address><CR>`

Description

Changes the communications address to a new value.

Data Parameters Sent

`new_address` is the new address for the monitor; Range for `new_address` is 1-9.

Response

`<address>:<success_flag>#<checksum><CR>`

Example

Command:

`1SETADDR:2<CR>` - Change address from 1 to 2

Response:

`1:OK#261<CR>` - Change Address Successful

`1:FAIL#391<CR>` - Change Address Failed

Notes

Note that monitor response is from previous address, but any further commands must be at new address. In the example above, after sending back the OK response, the monitor will no longer respond to commands with address 1.

5.4.6 TDUMP

Syntax

<address>TDUMP<CR>

Description

Returns the current measured parameters: O3 Concentration, Cell Pressure(psia,) Cell Temperature (K,) Lamp Temperature (K,) Measure Detector (mV,) Calibrated Reference Detector (mV,) Reference Detector (mV)

Data Parameters Sent

None

Response

<address>:<o3_conc>,<pressure>,<cell_temp>,<lamp_temp>,<measure>,<cal_ref>,<reference>#<checksum><CR>

Example

Command:
1TDUMP<CR>

Response:
1:0.0282144,14.77461,300.7179,324.7713,2881.437,2940.903,4412.52#3228<CR>

Notes

Note that the concentration value returned shows more digits after the decimal than the front panel display. Concentration values should only be considered valid to 4 significant digits.

5.4.7 TLIST

Syntax

<address>TLIST<CR>

Description

Returns a verbose list of the current measured parameters with labels for each parameter: O3 Concentration, Cell Pressure(psia,) Cell Temperature (K,) Lamp Temperature (K,) Measure Detector (mV,) Calibrated Reference Detector (mV,) Reference Detector (mV)

Data Parameters Sent

None

Response

Test Parameter List (See Below)

Example

Command:

```
1TLIST<CR>
```

Response:

```
O3 = 0.0226168  
Press = 14.7753  
Cell Temp = 300.7116  
Lamp Temp = 324.7965  
Ref = 2881.52  
Meas = 2941.092  
Raw Ref = 4412.646
```

Notes

Note that the concentration value returned shows more digits after the decimal than the front panel display. Concentration values should only be considered valid to 4 significant digits.

Also, note that no checksum is sent in the response to the TLIST command.

5.4.8 VGET

Syntax

<address>VGET:<var_index><CR>

Description

Returns value of an internal configuration variable (VAR.)

Data Parameters Sent

var_index is index number for internal VAR as follows:

Var Index	Name	Description	Allowable Range
0	analog_range	Full-Scale concentration range for Analog Output scaling	5.0 – 400.0 (Units are current unit of measure, wt% or g/Nm ³)
1	azero_enable	Auto-Zero Enable VAR. (only valid if Auto-Zero hardware is installed)	0 = Off 1 = On
2	azero_period	Period for Auto-Zero Calibration timer	5.0 - 86400.0 Seconds
3	carrier_weight	Mol weight of carrier gas for wt% calculations (32.0 = O ₂)	27.0 – 32.0 mol weight
4	comm_mode	Not Used	N/A
5	iir_filt	Digital Concentration filter	0.05 – 1.0 (1.0 = No Filtering, lower values increases filtering)
6	conc_units	O ₃ Concentration measurement units	0 = wt% 1 = g/Nm ³

Response

<address>:<var_value>#<checksum><CR>

Example

Command:

1VGET:0<CR> - Request analog_range value

Response:

1:15.0#303 - analog_range returned as 15.0 (wt%)

5.4.9 VLIST

Syntax

<address>VLIST<CR>

Description

Returns a verbose list of an internal configuration variables (VARs.)

Data Parameters Sent

None

Response

Var List (See Below)

Example

Command:

```
1VLIST<CR>
```

Response:

```
#0 analog_range = 15.0  
#1 azero_enable = 0.0  
#2 azero_period = 720.0  
#3 carrier_weight =32.0  
#4 comm_mode = 0.0  
#5 iir_filt = 0.4  
#6 conc_units = 0.0
```

Notes

Note that no checksum is sent in the response to the VLIST command.

5.4.10 VSET

Syntax

<address>VSET:<var_index>,<new_value><CR>

Description

Sets value of an internal configuration variable (VAR.)

Data Parameters Sent

var_index is index number for internal VAR (See VGET for index list)

new_value new value for VAR.

Response

<address>:<var_value>#<checksum><CR>

Example

Command:

1VSET:0,15.0<CR> - Set analog_range VAR to 15.0 (wt%)

Response:

1:OK#261<CR> - VSET Successful

1:FAIL#391<CR> - VSET Failed

6.0 Maintenance

6.1 Replacing the gas filter element

The Model 460H is equipped with a gas filter on the ozone inlet. These filters accept 25mm diameter glass fiber elements. Only filter elements of borosilicate glass or quartz fibers should be used. When the instrument is first installed, the sample filters should be checked at least once a week for particulate loading and replaced if necessary. Once the replacement frequency is determined, a regular schedule for filter replacement should be instituted.

For replacement 25mm filter elements, please contact API's sales department and request part number 02851.

Filter Replacement Procedure:

1. First ensure that the gas delivery line is not under pressure and has been purged of ozone.
2. Remove the four screws securing the gas filter assembly.
3. Remove the bottom half of the filter housing
4. Examine the internal sealing o-ring and replace if necessary.
5. Pull out the stainless steel screen securing the filter element.
6. The element can now be removed and replaced. When re-assembling filter, make sure that the top stainless steel screen is pushed into the filter cavity, securing the element in place.
7. After re-assembly, the gas line should be pressurized with oxygen or dry air and checked for leaks using a bubble solution.

6.2 Cleaning Exterior Surfaces of the M460H

If necessary, the exterior surfaces of M454H can be cleaned with a damp cloth. Do not attempt to clean any of the other surfaces of the instrument. Do not submerge any part of the instrument in water or cleaning solution.

6.3 Degree of Protection

The Model 460NEMA has a water ingress rating of IPX65 which indicates that it can withstand strong jets of water and is totally protected against dust.

7.0 Sensor and System Troubleshooting

This chapter gives guidelines for diagnosing system and sensor malfunctions using the five digital Status Outputs provided by the M460H. All troubleshooting should be done after the M460H has been turned on and allowed to warm up for at least 15 minutes.

7.1 Status Output Summary

Table 7-1 below gives a summary of the operation of the five Status Outputs on the M454H. See 2.4.2 Digital Status Outputs for information on connecting these outputs.

Table 7-1: Digital Status Outputs

Output #	Name	On State	Off state
1	Sensor O.K.	Normal State	Reference or Measure > 4995mV; Reference < 1000mV
2	Invalid Reading	Pressure > 45 psia, Negative Ozone Concentration, Concentration Over-Range	Normal State
3	Lamp Low	Reference Detector < 2500mV	Normal State
4	Cell Dirty	Measure/Reference ratio < 0.5 (zero gas)	Normal State
5	Auto-Zero Error	Auto-Zero Failed	Normal State

7.2 Sensor OK

The normal state for the Sensor OK output is ON. During the warm-up period on start-up this output will stay off until the UV lamp reaches a minimum intensity. If this output remains off after the 15 minute warm-up period, or goes off during normal operation, then the M460H is in need of servicing.

If the Sensor O.K. output turns off AND the Lamp Low output is on, this indicates that the lamp intensity has below the minimum level required for proper operation.

If the Sensor O.K. output turns off and the Lamp Low output is also off, then one of the analog voltages in the sensor has exceeded the range of the internal A/D converter. Adjustment by qualified service personnel is required.

7.3 Invalid Reading

The normal state for the Invalid Reading output is OFF. If this output turns on, this indicates that the M460H is still operational, but a system fault or calibration fault exists that may make the current ozone reading invalid.

The Invalid Reading output is turned on for any of the following conditions:

1. When the measured pressure in the measurement cell exceeds 45 psia.
2. When the measured concentration has exceeded the full-scale concentration range of the sensor. Check the serial number tag for the full-scale concentration range.
3. The sensor is indicating an excessive negative reading.

7.4 Lamp Low

The normal state for the Lamp Low output is OFF. If this output turns on, this indicates that the UV lamp intensity as measured by the reference detector has dropped below 2500mV.

If the Lamp Low output turns ON and the Sensor O.K. output is ON, this indicates that the lamp intensity is still adequate for measurement, but adjustment should be made when possible.

If the Lamp Low output turns ON and the Sensor O.K. output is OFF, this indicates a failure condition and measurement is no longer possible.

7.5 Cell Dirty

The normal state for the Cell Dirty output is OFF. If this output turns on, then the ratio of the measure detector to the reference detector (at zero) is < 0.5 . This value is calculated when the zero calibration is performed.

When this output is on, it indicates a loss of optical transmission through the windows in the absorption cell or a calibration fault.

7.6 Status Output Summary Table

Table 7-2 below is a logic truth table summarizing the recommended actions based on the states of the four status outputs. A '1' indicates the output is ON, a '0' indicates the output is OFF, and 'X' indicates the output is in either state.

Table 7-2: Status Output Truth Table

Sensor OK	Invalid Reading	Lamp Low	Cell Dirty	Actions
1	0	0	0	Normal operation, no action required
0	X	X	X	Service required
1	1	X	X	Check Pressure > 45 psia Verify that concentration has not exceeded full scale range of sensor. Calibrate at Zero.
1	X	1	X	Lamp adjustment useful, though not required
1	X	X	1	Calibrate at zero Clean Cell

Appendix A – Serial Port Configuration

To configure the com port for RS232 or RS485, move the 4 shunts on JP3 of the Controller PCA (#03492) to the proper position as shown in Figure A-1.

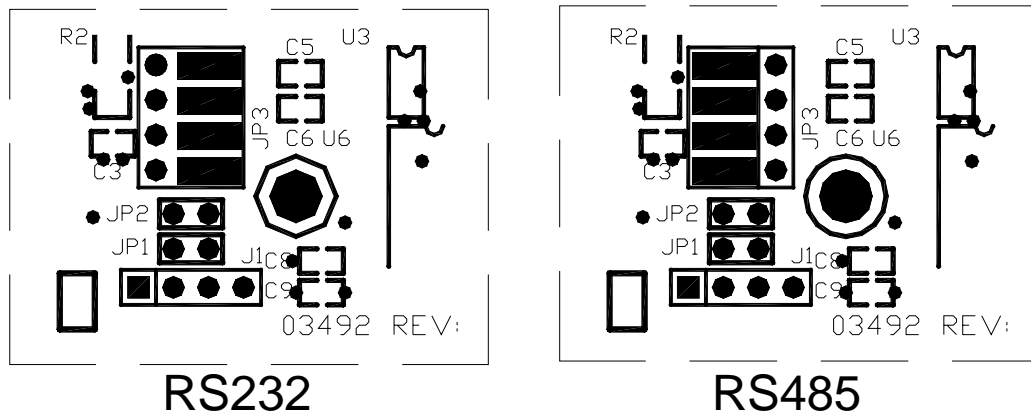

Figure A-1 RS232/RS485 Jumpers (Controller PCA#03492)

Appendix B – Pneumatic Diagram

