

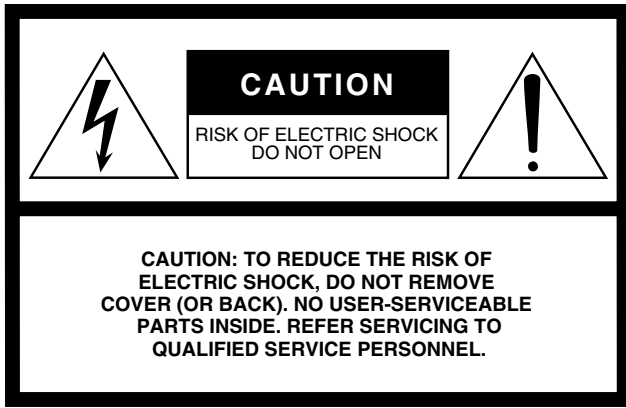

DIGITAL MIXING ENGINE SATELLITE
DME8i-C / DME8o-C / DME4io-C

Owner's Manual



The above warning is located on the top of the unit.

Explanation of Graphical Symbols

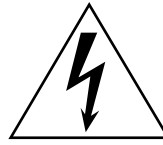

The lightning flash with arrowhead symbol within an equilateral triangle is intended to alert the user to the presence of uninsulated “dangerous voltage” within the product’s enclosure that may be of sufficient magnitude to constitute a risk of electric shock to persons.



The exclamation point within an equilateral triangle is intended to alert the user to the presence of important operating and maintenance (servicing) instructions in the literature accompanying the product.

IMPORTANT SAFETY INSTRUCTIONS

- 1 Read these instructions.
- 2 Keep these instructions.
- 3 Heed all warnings.
- 4 Follow all instructions.
- 5 Do not use this apparatus near water.
- 6 Clean only with dry cloth.
- 7 Do not block any ventilation openings. Install in accordance with the manufacturer’s instructions.
- 8 Do not install near any heat sources such as radiators, heat registers, stoves, or other apparatus (including amplifiers) that produce heat.
- 9 Do not defeat the safety purpose of the polarized or grounding-type plug. A polarized plug has two blades with one wider than the other. A grounding type plug has two blades and a third grounding prong. The wide blade or the third prong are provided for your safety. If the provided plug does not fit into your outlet, consult an electrician for replacement of the obsolete outlet.
- 10 Protect the power cord from being walked on or pinched particularly at plugs, convenience receptacles, and the point where they exit from the apparatus.
- 11 Only use attachments/accessories specified by the manufacturer.
- 12 Use only with the cart, stand, tripod, bracket, or table specified by the manufacturer, or sold with the apparatus. When a cart is used, use caution when moving the cart/apparatus combination to avoid injury from tip-over.
- 13 Unplug this apparatus during lightning storms or when unused for long periods of time.
- 14 Refer all servicing to qualified service personnel. Servicing is required when the apparatus has been damaged in any way, such as power-supply cord or plug is damaged, liquid has been spilled or objects have fallen into the apparatus, the apparatus has been exposed to rain or moisture, does not operate normally, or has been dropped.



WARNING

TO REDUCE THE RISK OF FIRE OR ELECTRIC SHOCK, DO NOT EXPOSE THIS APPARATUS TO RAIN OR MOISTURE.

(98-6500)

This product contains a battery that contains perchlorate material.
Perchlorate Material—special handling may apply,
See www.dtsc.ca.gov/hazardouswaste/perchlorate.

* This applies only to products distributed by YAMAHA CORPORATION OF AMERICA. (Perchlorate)

FCC INFORMATION (U.S.A.)

1. IMPORTANT NOTICE: DO NOT MODIFY THIS UNIT!

This product, when installed as indicated in the instructions contained in this manual, meets FCC requirements. Modifications not expressly approved by Yamaha may void your authority, granted by the FCC, to use the product.

2. IMPORTANT: When connecting this product to accessories and/or another product use only high quality shielded cables. Cable/s supplied with this product MUST be used. Follow all installation instructions. Failure to follow instructions could void your FCC authorization to use this product in the USA.

3. NOTE: This product has been tested and found to comply with the requirements listed in FCC Regulations, Part 15 for Class "B" digital devices. Compliance with these requirements provides a reasonable level of assurance that your use of this product in a residential environment will not result in harmful interference with other electronic devices. This equipment generates/uses radio frequencies and, if not installed and used according to the instructions found in the users manual, may cause interference harmful to the operation of other electronic devices. Compliance with FCC regulations does

not guarantee that interference will not occur in all installations. If this product is found to be the source of interference, which can be determined by turning the unit "OFF" and "ON", please try to eliminate the problem by using one of the following measures:

Relocate either this product or the device that is being affected by the interference.

Utilize power outlets that are on different branch (circuit breaker or fuse) circuits or install AC line filter/s.

In the case of radio or TV interference, relocate/reorient the antenna. If the antenna lead-in is 300 ohm ribbon lead, change the lead-in to co-axial type cable.

If these corrective measures do not produce satisfactory results, please contact the local retailer authorized to distribute this type of product. If you can not locate the appropriate retailer, please contact Yamaha Corporation of America, Electronic Service Division, 6600 Orangethorpe Ave, Buena Park, CA90620

The above statements apply ONLY to those products distributed by Yamaha Corporation of America or its subsidiaries.

* This applies only to products distributed by YAMAHA CORPORATION OF AMERICA.

(class B)

COMPLIANCE INFORMATION STATEMENT (DECLARATION OF CONFORMITY PROCEDURE)

Responsible Party : Yamaha Corporation of America
Address : 6600 Orangethorpe Ave., Buena Park, Calif.
90620
Telephone : 714-522-9011
Type of Equipment : DIGITAL MIXING ENGINE SATELLITE
Model Name : DME8i-C/DME8o-C/DME4io-C

This device complies with Part 15 of the FCC Rules.

Operation is subject to the following two conditions:

- 1) this device may not cause harmful interference, and
- 2) this device must accept any interference received including interference that may cause undesired operation.

See user manual instructions if interference to radio reception is suspected.

* This applies only to products distributed by
YAMAHA CORPORATION OF AMERICA.

(FCC DoC)

ADVARSEL!

Lithiumbatteri—Eksplodingsfare ved fejlagtig håndtering. Udskiftning må kun ske med batteri af samme fabrikat og type. Levér det brugte batteri tilbage til leverandoren.

WARNING

Explosionsfara vid felaktigt batteritype. Använd samma batterityp eller en ekvivalent typ som rekommenderas av apparattillverkaren. Kassera använt batteri enligt fabrikantens instruktion.

VAROITUS

Paristo voi räjähtää, jos se on virheellisesti asennettu. Vaihda paristo ainoastaan laitevalmistajan suosittelemaan tyyppiin. Hävitä käytetty paristo valmistajan ohjeiden mukaisesti.

(lithium caution)

NEDERLAND / THE NETHERLANDS

- Dit apparaat bevat een lithium batterij voor geheugen back-up.
- This apparatus contains a lithium battery for memory back-up.
- Raadpleeg uw leverancier over de verwijdering van de batterij op het moment dat u het apparaat aan het einde van de levensduur of gelieve dan contact op te nemen met de vertegenwoordiging van Yamaha in uw land.
- For the removal of the battery at the moment of the disposal at the end of life please consult your retailer or Yamaha representative office in your country.
- Gooi de batterij niet weg, maar lever hem in als KCA.
- Do not throw away the battery. Instead, hand it in as small chemical waste.

(lithium disposal)

IMPORTANT NOTICE FOR THE UNITED KINGDOM

Connecting the Plug and Cord

WARNING: THIS APPARATUS MUST BE EARTHED

IMPORTANT. The wires in this mains lead are coloured in accordance with the following code:

GREEN-AND-YELLOW	: EARTH
BLUE	: NEUTRAL
BROWN	: LIVE

As the colours of the wires in the mains lead of this apparatus may not correspond with the coloured markings identifying the terminals in your plug proceed as follows:

The wire which is coloured GREEN-and-YELLOW must be connected to the terminal in the plug which is marked by the letter E or by the safety earth symbol  or colored GREEN or GREEN-and-YELLOW.

The wire which is coloured BLUE must be connected to the terminal which is marked with the letter N or coloured BLACK.

The wire which is coloured BROWN must be connected to the terminal which is marked with the letter L or coloured RED.

• This applies only to products distributed by Yamaha-Kemble Music (U.K.) Ltd.(3 wires)

PRECAUTIONS

PLEASE READ CAREFULLY BEFORE PROCEEDING

* Please keep this manual in a safe place for future reference.



WARNING

Always follow the basic precautions listed below to avoid the possibility of serious injury or even death from electrical shock, short-circuiting, damages, fire or other hazards. These precautions include, but are not limited to, the following:

Power supply/Power cord

- Only use the voltage specified as correct for the device. The required voltage is printed on the name plate of the device.
- Use only the included power cord. If you intend to use the device in an area other than in the one you purchased, the included power cord may not be compatible. Please check with your Yamaha dealer.
- Do not place the power cord near heat sources such as heaters or radiators, and do not excessively bend or otherwise damage the cord, place heavy objects on it, or place it in a position where anyone could walk on, trip over, or roll anything over it.
- Be sure to connect to an appropriate outlet with a protective grounding connection. Improper grounding can result in electrical shock.

Do not open

- Do not open the device or attempt to disassemble the internal parts or modify them in any way. The device contains no user-serviceable parts. If it should appear to be malfunctioning, discontinue use immediately and have it inspected by qualified Yamaha service personnel.

Water warning

- Do not expose the device to rain, use it near water or in damp or wet conditions, or place containers on it containing liquids which might spill into any openings.
- Never insert or remove an electric plug with wet hands.

If you notice any abnormality

- If the power cord or plug becomes frayed or damaged, or if there is a sudden loss of sound during use of the device, or if any unusual smells or smoke should appear to be caused by it, immediately turn off the power switch, disconnect the electric plug from the outlet, and have the device inspected by qualified Yamaha service personnel.
- If this device should be dropped or damaged, immediately turn off the power switch, disconnect the electric plug from the outlet, and have the device inspected by qualified Yamaha service personnel.



CAUTION

Always follow the basic precautions listed below to avoid the possibility of physical injury to you or others, or damage to the device or other property. These precautions include, but are not limited to, the following:

Power supply/Power cord

- Remove the electric plug from the outlet when the device is not to be used for extended periods of time, or during electrical storms.
- When removing the electric plug from the device or an outlet, always hold the plug itself and not the cord. Pulling by the cord can damage it.

Location

- Before moving the device, remove all connected cables.
- When setting up the product, make sure that the AC outlet you are using is easily accessible. If some trouble or malfunction occurs, immediately turn off the power switch and disconnect the plug from the outlet. Even when the power switch is turned off, electricity is still flowing to the product at the minimum level. When you are not using the product for a long time, make sure to unplug the power cord from the wall AC outlet.
- If this device is to be mounted in an EIA-standard rack, leave the back of the rack open and make sure that it is at least 10 cm away from walls or surfaces. Also, if this device is to be mounted with devices that tend to generate heat, such as power amplifiers, be sure to keep an adequate gap between this device and the heat-generating devices or install ventilation panels to prevent high temperatures from developing inside this device.

Inadequate ventilation can result in overheating, possibly causing damage to the device(s), or even fire.

- If several of the devices are mounted in an EIA-compliant rack, carefully read the section "Precautions for Using a Rack-mounted DME Satellite" on page 8.
- Avoid setting all equalizer controls and faders to their maximum. Depending on the condition of the connected devices, doing so may cause feedback and may damage the speakers.
- Do not expose the device to excessive dust or vibrations, or extreme cold or heat (such as in direct sunlight, near a heater, or in a car during the day) to prevent the possibility of panel disfiguration or damage to the internal components.
- Do not place the device in an unstable position where it might accidentally fall over.
- Do not block the vents. This device has ventilation holes at the rear to prevent the internal temperature from becoming too high. In particular, do not place the device on its side or upside down. Inadequate ventilation can result in overheating, possibly causing damage to the device(s), or even fire.
- Do not use the device in the vicinity of a TV, radio, stereo equipment, mobile phone, or other electric devices. Doing so may result in noise, both in the device itself and in the TV or radio next to it.

Connections

- Before connecting the device to other devices, turn off the power for all devices. Before turning the power on or off for all devices, set all volume levels to minimum.

Handling caution

- Do not insert your fingers or hands in any gaps or openings on the device.
- Avoid inserting or dropping foreign objects (paper, plastic, metal, etc.) into any gaps or openings on the device. If this happens, turn off the power immediately and unplug the power cord from the AC outlet. Then have the device inspected by qualified Yamaha service personnel.
- Do not use the device for a long period of time at a high or uncomfortable volume level, since this can cause permanent hearing loss. If you experience any hearing loss or ringing in the ears, consult a physician.
- Do not rest your weight on the device or place heavy objects on it, and avoid use excessive force on the buttons, switches or connectors.

Backup battery

- This device has a built-in backup battery. When you unplug the power cord from the AC outlet, the current scene data is retained. However, the life of the backup battery is about five years. If the battery wears out, the current scene data will be lost. When the backup battery charge becomes low, the [ERROR] indicator on the front panel blinks. In this case, save the data to a computer immediately, then ask a Yamaha dealer to replace the backup battery.

Do not turn the [POWER] switch on and off repeatedly and rapidly. Be sure to wait six seconds or more between turning the power to the unit off and then on.

The rubber feet included in this package can be attached to the bottom of this device to prevent slippage when it is to be used on a slippery surface.

Yamaha cannot be held responsible for damage caused by improper use or modifications to the device, or data that is lost or destroyed.

Always turn the power off when the device is not in use.

The performance of components with moving contacts, such as switches, volume controls, and connectors, deteriorates over time. Consult qualified Yamaha service personnel about replacing defective components.

- The illustrations in this owner's manual are for instructional purposes, and may appear somewhat different from the actual equipment.
- CobraNet is a trademark of Cirrus Logic, Inc.
- Ethernet is a trademark of Xerox Corporation.
- All other trademarks are the property of their respective holders and are hereby acknowledged.

Contents

Foreword 7

Accessories (Please make sure the following items are included in the package.)	7
Options.....	7
About the Product Names.....	7
About the Firmware Version	7
Preparation.....	7
Connecting the AC power cord.....	7
Turning the power on and off.....	7
Precautions for Using a Rack-mounted DME Satellite	8

Introduction to the DME Satellite 9

Differences between DME8i-C, DME8o-C, and DME4io-C	9
DME Satellite Features	9
Audio System Network	10
Glossary for the DME Satellite.....	10
Signal Types.....	12
System Examples.....	13
About DME Designer.....	14
About CobraNet	15
CobraNet in a nutshell.....	15
Bundle	15
Multicast and unicast bundles	16
Conductors and performers.....	17
Cables and hubs for CobraNet network	17

Controls and Connectors 18

Front Panel	18
Rear Panel.....	20

Connecting to a Computer 22

USB Connection.....	22
Network Settings.....	23
Setting the IP address.....	23
Master and slave setting.....	23
Ethernet Connection ([NETWORK] Connector).....	24

Audio I/O Connection 28

Digital Audio Connection (CobraNet Connectors).....	28
Analog Audio Connection ([INPUT] & [OUTPUT] Connectors)	29

Connecting to an External Device..... 30

Remote Connection ([REMOTE] Connector)	30
Controlling external head amplifiers from the DME Satellite	30
Controlling a DME Satellite's internal head amps from a digital mixer	31
Controlling the DME Satellite from an external device.....	31
CobraNet Connection (CobraNet Connectors).....	32
Controlling DME Satellite's internal head amps from a digital mixer Yamaha LS9	32
Controlling the DME Satellite from a digital mixer Yamaha PM5D	33
Network Connection ([NETWORK] Connectors	33
GPI Connection ([GPI] Connector).....	34

Other Functions..... 35

Initializing the DME Satellite.....	35
-------------------------------------	----

References 36

Options	36
ICP1	36
CP4SW, CP4SF, and CP1SF.....	36
Troubleshooting.....	37
Component.....	37
MIDI Data Format	38
1. MIDI functions on the DME8i-C, DME8o-C, and DME4io-C.....	38
2. MIDI Data Flow	38
3. MIDI Setup	38
4. MIDI Format	39
MIDI Implementation Chart	41
Display Messages	42
Error Messages	42
Warning Messages	42
General Specifications	43
Electrical Characteristics	43
Input/Output Characteristics	46
[NETWORK] Connector (100Base-TX Ethernet, RJ-45)	47
Straight and Crossover Cable Wiring.....	47
Dimensions	48
Index	49

Foreword

Thank you for choosing a Yamaha DME8i-C/DME8o-C/DME4io-C Digital Mixing Engine Satellite.

In order to take full advantage of the features and performance provided by the DME8i-C/DME8o-C/DME4io-C, we urge you to read this owner's manual thoroughly before connecting or using the unit. Keep this manual in a safe place for future reference.

Accessories (Please make sure the following items are included in the package.)

- DME8i-C/DME8o-C/DME4io-C Owner's Manual (this document)
- AC power cord
- Euroblock plug (16P) x 1
- Euroblock plug (3P) x 8
- Rubber feet x 4

Options

Control Panels

- ICP1 Intelligent Control Panel
- CP4SW Control Panel
- CP4SF Control Panel
- CP1SF Control Panel

NOTE

For more information on your Control Panel, refer to the owner's manual that came with the Control Panel, as well as the DME Designer Owner's Manual.

About the Product Names

In this manual, models DME8i-C, DME8o-C, and DME4io-C are all called "DME Satellite," and models DME64N and DME24N, DME8i-ES/DME8o-ES/DME4io-ES and the DME Satellite are categorized as the DME series.

About the Firmware Version

You can check the version number of the DME Satellite firmware by using the DME Designer application software. You can also download the latest firmware from the following Yamaha website.

<http://www.yamahaproaudio.com/>

Preparation

Connecting the AC power cord



Be sure to turn all devices OFF before connecting AC mains power.

First plug the female-connector end of the AC cord into the [AC IN] socket on the rear panel of the DME Satellite, then plug the male plug into an appropriate AC mains outlet. Be sure to use the voltage specified for the device.

Turning the power on and off



To prevent the initial power-on surge from generating a large noise spike or damaging your speaker system, turn the devices on in the following order: audio sources, mixer (such as M7CL or PM5D), DME Satellite, and finally power amplifiers. Reverse this order when turning power off.

1. Press the [POWER] switch to turn on the power to the DME Satellite.
2. Press the [POWER] switch again to turn off the power.

NOTE

The DME Satellite remembers scene settings when you turn off the power. When you turn on the power to the DME Satellite, it will start up with the same scene settings. You can use the "Last Mem. Resume" setting in DME Designer to set up the DME Satellite so that at the startup it will recall the scene selected before you turned off the power to the device.



- Do NOT turn off the power to the DME Satellite while it is receiving data from DME Designer or while it is being manipulated from an external device. Otherwise, a malfunction may occur.
- Even when the power switch is turned off, electricity is still flowing to the product all the minimum level. When you are not using the product for a long time, make sure to unplug the power cord from the wall AC outlet.

Precautions for Using a Rack-mounted DME Satellite

If several DME Satellite units (or a DME Satellite unit together with other devices) are installed in a poorly-ventilated rack, the heat generated by each unit may raise the temperature inside the rack, preventing the DME Satellite from performing as designed. When mounting DME Satellite units in a rack, please leave one rack space vacant for every two units. You can attach a ventilation panel to this space or leave it open to prevent excessive heat build-up.

If the temperature inside the rack is expected to rise above 40 degrees Celsius or 104 degrees Fahrenheit (or if the ambient temperature outside the rack is expected to rise above 30 degrees Celsius or 86 Fahrenheit), install a fan kit in the top row of the rack. The fan must provide airflow of 1.6m³/min or more and static pressure of 5mmH₂O or more.

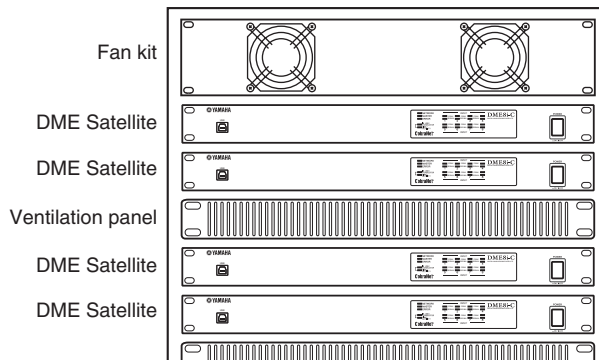

Differences between DME8i-C, DME8o-C, and DME4io-C

The differences between these three models are as follows:

■ DME8i-C

This model features 8-channel analog inputs.

■ DME8o-C

This model features 8-channel analog outputs.

■ DME4io-C

This model features 4-channel analog inputs and 4-channel analog outputs.

DME Satellite Features

In addition to basic mixing and matrix output functions, the DME Satellite includes a equalizers, compressors, delay, etc. – that can be patched together via DME Designer to configure just about any audio system you need. The CobraNet connectors on the device enable you to remotely control analog inputs and outputs by transferring digital audio signals via a network.

The following steps summarize the process for setting up the DME Satellite for use:
(For details, refer to the “DME Setup Manual”.)

- 1. Install USB-MIDI Driver, DME Designer and DME-N Network Driver.**
- 2. Set up the network from DME Designer (page 23).**
- 3. Connect devices.**
 - **Network connection**
Ethernet connection (page 24)
USB connection (page 22)
 - **CobraNet connection (page 32)**
 - **Analog connection (page 29)**
 - **External device connection**
Remote connection (page 30)
GPI connection (page 34)
- 4. Make network settings on your computer.**
- 5. Create a configuration using DME Designer, then transfer it to the DME Satellite.**
(Refer to the DME Designer Owner’s Manual for details.)

Audio System Network

Multiple DME series units that are interconnected in a network via Ethernet function as a single audio system. In a DME audio system, a group of the same models that can be operated in sync is called a “device group;” audio processing divisions that accommodate multiple device groups are called “zones;” and the entire area serviced by the acoustic system is called an “area.”

Each device group always includes one DME series unit that functions as the “group master” and controls all other DME series units in the same device group.

If a computer is connected to the network, you can use the computer to control an entire device group via the group master.

Glossary for the DME Satellite

This section explains terminology specific to the DME Satellite.

Components and parameters

The individual audio processing modules (equalizers, compressors, etc.) are called “components.”

External head amplifier control modules are also available as components.

Changing the parameters of components enables control over the operation of the components.

Configuration

A “configuration” is a complete set of components for constructing an audio system.

Each configuration determines the audio function(s) of the corresponding DME Satellite unit.

All parameter sets included with each component in a configuration are called “preset parameters.”

One DME Satellite unit has a number of configurations, and a configuration has a number of preset parameters.

User Defined buttons (User Defined parameters)

Assigning parameters to be User Defined parameters enables you to control the device from the ICP1 and the DME64N/DME24N.

Refer to the DME Designer Owner’s Manual for details.

Scene

A combination of all configuration and preset parameters is called a “scene.”

Scenes can be recalled from an ICP1, GPI device, other external controllers, DME64N/DME24N, or computer.

Up to 999 scenes can be stored for each device group.

Scene structure

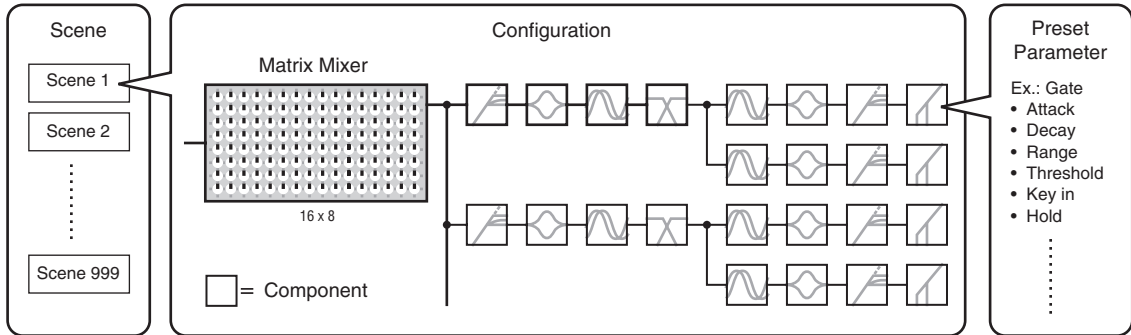

Scene change

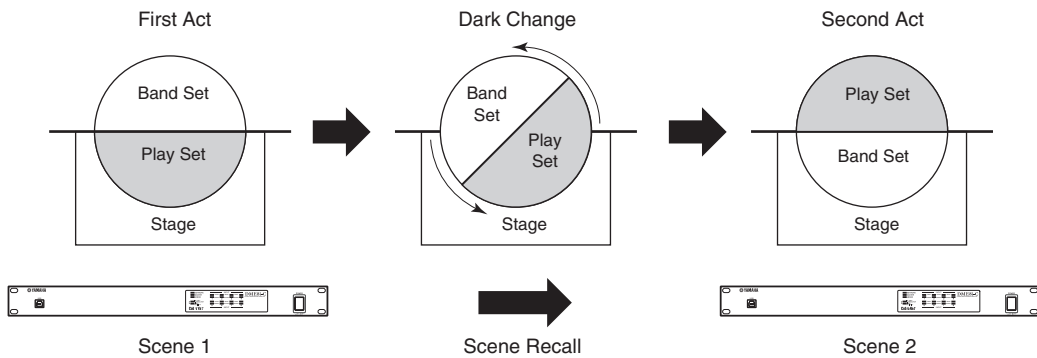

Signal Types

DME Satellite audio system signals can be broadly categorized as follows.

1 Audio

Analog and digital signals are input and output between the DME Satellite, other DME series units, and other audio devices.

Analog signals are input and output via the [INPUT]/[OUTPUT] jacks. Digital signals are input and output via the CobraNet jacks.

2 Device group control

Device group control signals control all DME series devices in the group.

There are two types of device group control signals, as follows:

- **Control signals between the computer and the group master DME series unit**
- **Control signals between the group master DME series unit and the other DME series units**

You can use the DME Designer application to control the entire device group, such as sending components to the devices and setting the parameters as required.

3 Device control

These signals provide communication and control between individual devices.

Included in this category are MIDI messages transferred between [USB] connectors, GPI signals transferred between [GPI] connectors, and remote head amp control signals handled via the [REMOTE] connector.

Type of signals handled by the DME Satellite

Connector	Audio Signal	Device Control	Reference Page
[USB] Connector	—	<ul style="list-style-type: none"> • Control signals between computer and DME Satellite • MIDI messages 	page 22
[NETWORK] Connector	—	<ul style="list-style-type: none"> • Control signals between computer and DME Satellite • Control signals between DME Satellites • Control signals with a controller such as an AMX or Crestron 	page 24
CobraNet Connector	Up to 16 channels of input and output.	<ul style="list-style-type: none"> • Internal head amp control signals with a digital mixer • Control signals between PM5D and DME Satellite. 	page 32
[GPI] Connector	—	GPI control signals between GPI device (GPI controller, etc.) and DME series unit	page 34
[REMOTE] Connector	—	<ul style="list-style-type: none"> • Control signals to/from an external device (such as AD8HR head amplifier) • Control signals for a digital mixer and internal head amp • Control signals with a controller such as an AMX or Crestron • MIDI messages 	page 30
[INPUT]/[OUTPUT] Connectors (audio in/out)	The number of I/O channels depends on model.	—	page 29

System Examples

Multiple DME Satellite units: Large-scale system

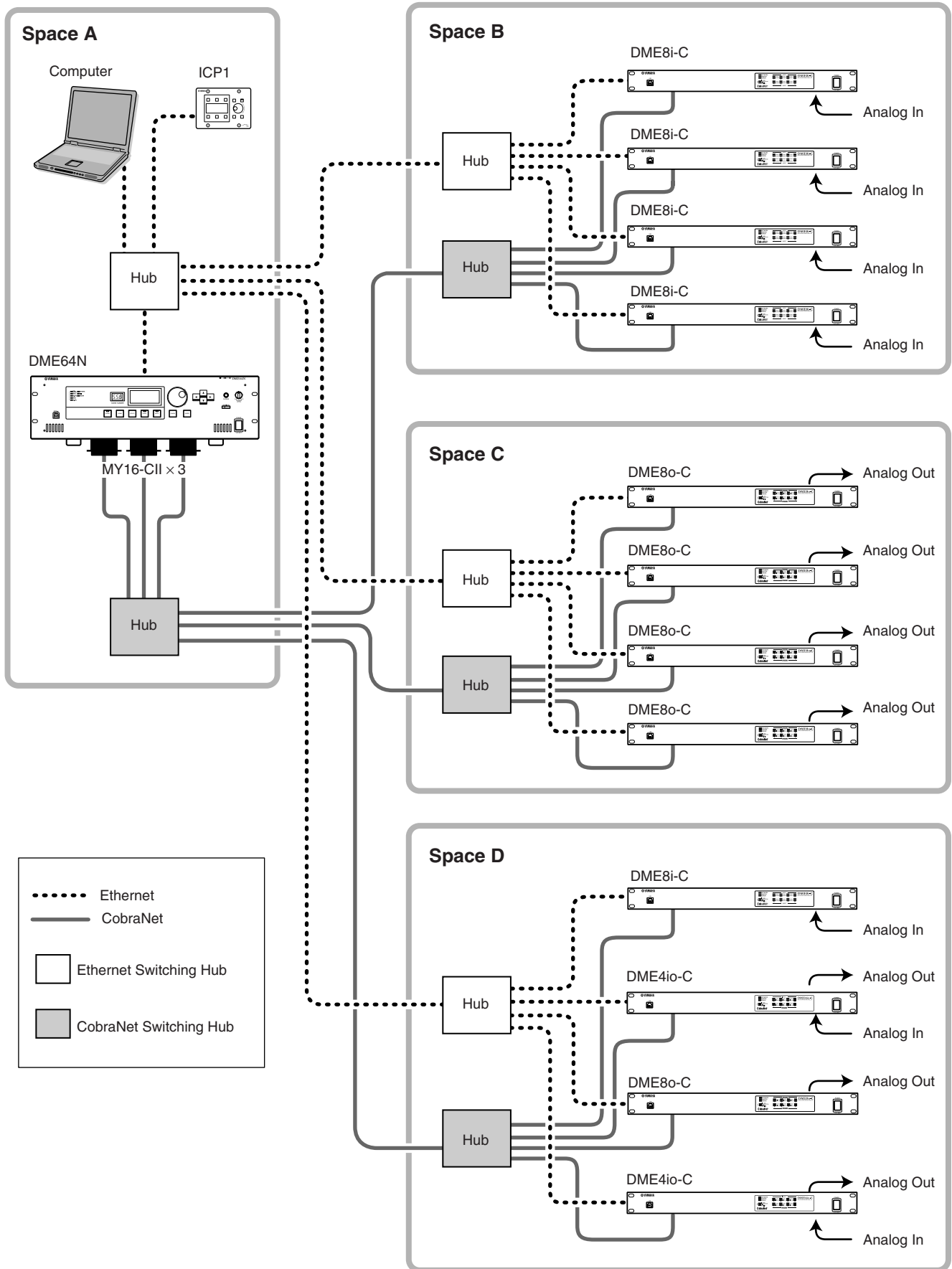

About DME Designer

DME Designer software enables you to integrate, configure, and control the DME series system from a connected computer.

You can build the DME series audio system using graphic blocks in DME Designer that are displayed on the computer monitor.

The DME series settings, configuration, and parameter data are transferred from the computer to the DME series unit via the USB or Ethernet connection.

DME series settings, configuration, and parameter data is sent via USB or Ethernet to the connected DME series unit. After the data is transmitted, you can disconnect the DME series unit from the computer and use it as an independent processor.

You can also connect it to a computer and control it in realtime from DME Designer.

If multiple DME series units are connected in the network, DME Designer enables you to build a configuration that includes those units.

Please download the DME Designer application, driver, DME setup manual, and DME Designer owner's manual at the following URL:

<http://www.yamahaproaudio.com/>

Refer to the "Connecting to a Computer" (page 22) for more information on connecting a computer to the DME Satellite. For details on how to install DME Designer and the drivers that are required for connection, refer to the "DME Setup Manual".

Refer to the DME Designer Owner's Manual for setup and operation instructions.

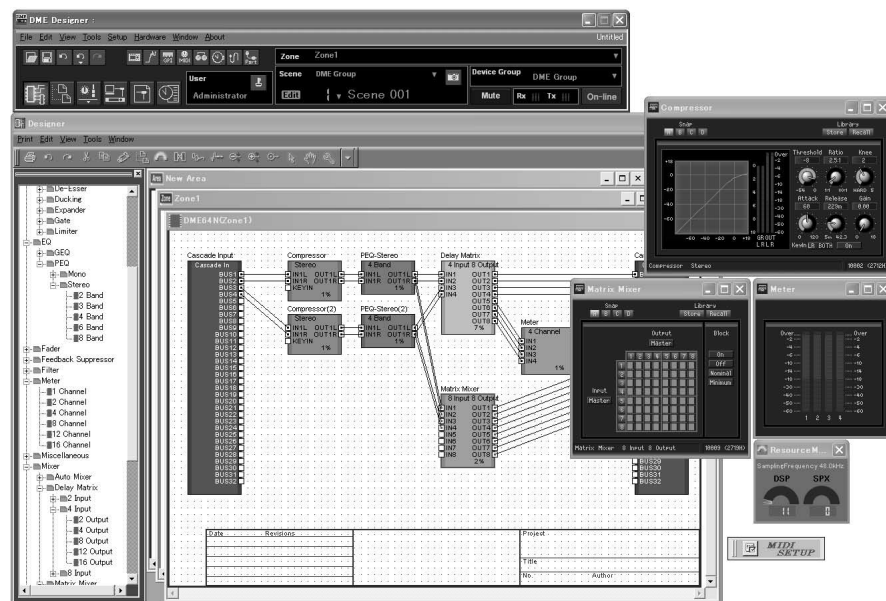

About CobraNet

CobraNet in a nutshell

Developed by Cirrus Logic, Inc., U.S., CobraNet technology allows real-time uncompressed digital audio distribution over industry-standard Fast Ethernet (100 megabits/sec.) networks.

Up to 128 channels, 64 in each direction, can be carried simultaneously over a CobraNet network. (The number of channels available depends on the performance of the devices and the condition of audio signals.) CobraNet currently supports a 48 or 96 kHz sampling rate with 16, 20, or 24-bit resolution.

It can also transfer control data along with audio signals.

The type of control data that the network can handle depends on the type of devices on the network.

When an audio signal passes through the CobraNet network, it causes a fixed latency of 5.33 milliseconds (or, depending on the setting, 2.67 or 1.33 milliseconds).

Visit the CobraNet home page for more information on CobraNet.

CobraNet home page

<http://www.cobranet.info/>

Bundle

CobraNet network transmits digital audio data in bundles. When bundles are received, they are converted back into the original digital audio data.

With the DME Satellite, a single bundle can carry up to eight channels of digital audio.

For routing around the network, bundles are assigned numbers from 1 through 65,279. If you set the same bundle number on both transmitting and receiving devices, digital audio data can be transmitted over CobraNet network. There is no limitation to the number of bundles that can be transmitted and received over the CobraNet network, as long as there are enough network resources.

The number of bundles that can be handled depends on the device.

The DME Satellite can use up to 4 output bundles and up to 8 input bundles.

You can specify the bundle number by using the DME Designer application.

The maximum number of channels that can be assigned to each bundle is as follows.

Maximum channels per bundle

Latency	16bit, 48kHz	20bit, 48kHz	24bit, 48kHz	16bit, 96kHz	20bit, 96kHz	24bit, 96kHz
5.33ms	8	8	7	4*	4*	3**
2.67ms	8	8	8	4*	4*	4*
1.33ms	8	8	8	4*	4*	4*

* Since 96-kHz audio is handled as two 48-kHz signals combined, the maximum number of channels is halved.

** The audio signal output from the 4th channel will include some aliasing noise, and proper operation cannot be guaranteed. Please do not use this channel.

NOTE

The number of channels per bundled can be changes as shown below.

Depending on the configuration, the maximum number of channels that can be handle may be less than 8.

Number of bundles per channel and usable channels

Channels per Bundle	Bundle 1	Bundle 2	Bundle 3	Bundle 4	Bundle 5	Bundle 6	Bundle 7	Bundle 8
8	1-8	9-16	–	–	–	–	–	–
4	1-4	5-8	9-12	13-16	–	–	–	–
2	1-2	3-4	5-6	7-8	9-10	11-12	13-14	15-16
1	1	2	3	4	5	6	7	8

Multicast and unicast bundles

CobraNet bundles can be either multicast or unicast.

Multicast bundles are transmitted from one device to multiple devices on the network (one-to-many). Unicast bundles are transmitted from one device to another (one-to-one).

Unicast bundles are transmitted only when another device is configured to receive them by assigning the same bundle numbers. On the other hand, multicast bundles are transmitted to all devices on the network regardless of whether any devices are configured to receive them, and only devices that are configured to receive those bundles actually process them.

It is recommended that no more than four multicast bundles (offering up to 32 channels) be used, since transmission of multicast bundles consumes more network resources.

Unicast bundles should be used if five or more bundles are required. It is also possible to set multiple devices to receive the same unicast bundle number, and depending on the transmitting device up to 4 receiving devices may be able to simultaneously receive the same bundle. This situation is known as “multi-unicast.” The DME Satellite is capable of handling multi-unicast bundles.

Multicast and unicast bundles are identified by bundle number. Multicast bundles are numbered 1 through 255. Unicast bundles are numbered 256 through 65,279.

Multicast bundle

If Device A is transmitting multicast bundles, they will be transmitted to all devices on the CobraNet network (e.g., Devices B, C, and D in the example).

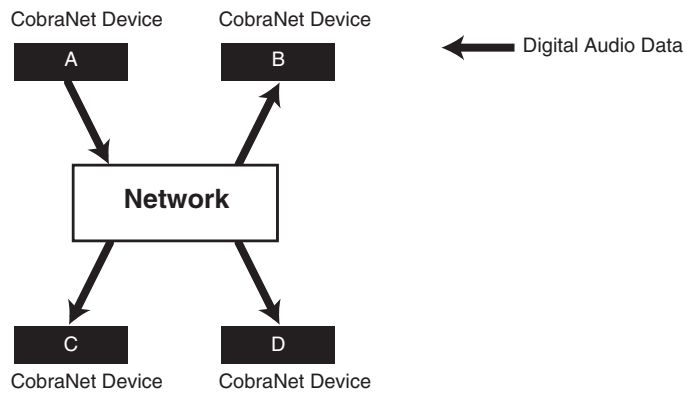

Unicast bundle

If Device A is transmitting unicast bundles, and the same bundle numbers are assigned to the transmitting bundles on Device A and receiving bundles on Device D, then Device A will transmit the unicast bundles to Device D.

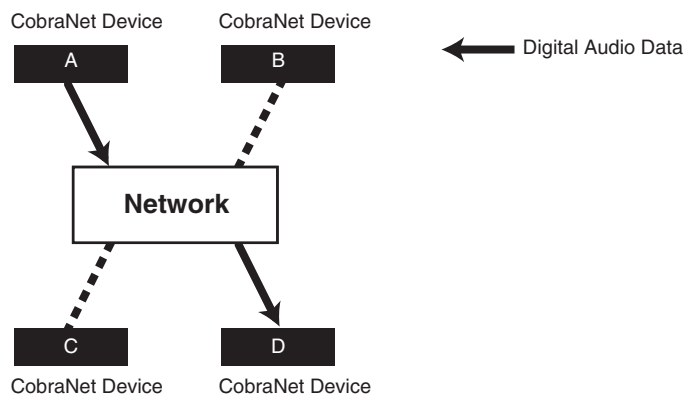

Conductors and performers

One device on the CobraNet network works as the conductor (network sync master). All other CobraNet devices are performers (network sync slaves). Each device synchronizes its own internal clock to the beat packets (sync signals) transmitted by the conductor.

The conductor device is chosen automatically and no user intervention is required.

However, setting an appropriate conductor priority could enable users to assign any device as the conductor. Refer to the DME Designer Owner's Manual for more information on setting the conductor priority.

If the DME Satellite is the conductor, the [IN USE/CONDUCTOR] LED flashes orange.

If the conductor fails, another device automatically takes over.

Since the conductor transmits beat packets (sync signals) onto the network, each performer does not require an external word clock connection, reducing cabling complexity and cost.

Any non-networked digital audio equipment should derive its word clock from a CobraNet networked device.

NOTE

All CobraNet networked devices, regardless of whether each device serves as the conductor or a performer, can receive digital audio data and control data.

Cables and hubs for CobraNet network

Category-5 metal cables can be used for runs of up to 100 meters. The maximum distance for multimode fiber optic cable is 2 kilometers.

However, due to differences in cables, as well as switching hub and CobraNet device performance, proper operation at the maximum length cannot be guaranteed in all cases.

Always use switching hubs in a CobraNet network. When using metal cable for connections, be sure to use Category 5 straight cables.

Controls and Connectors

Front Panel

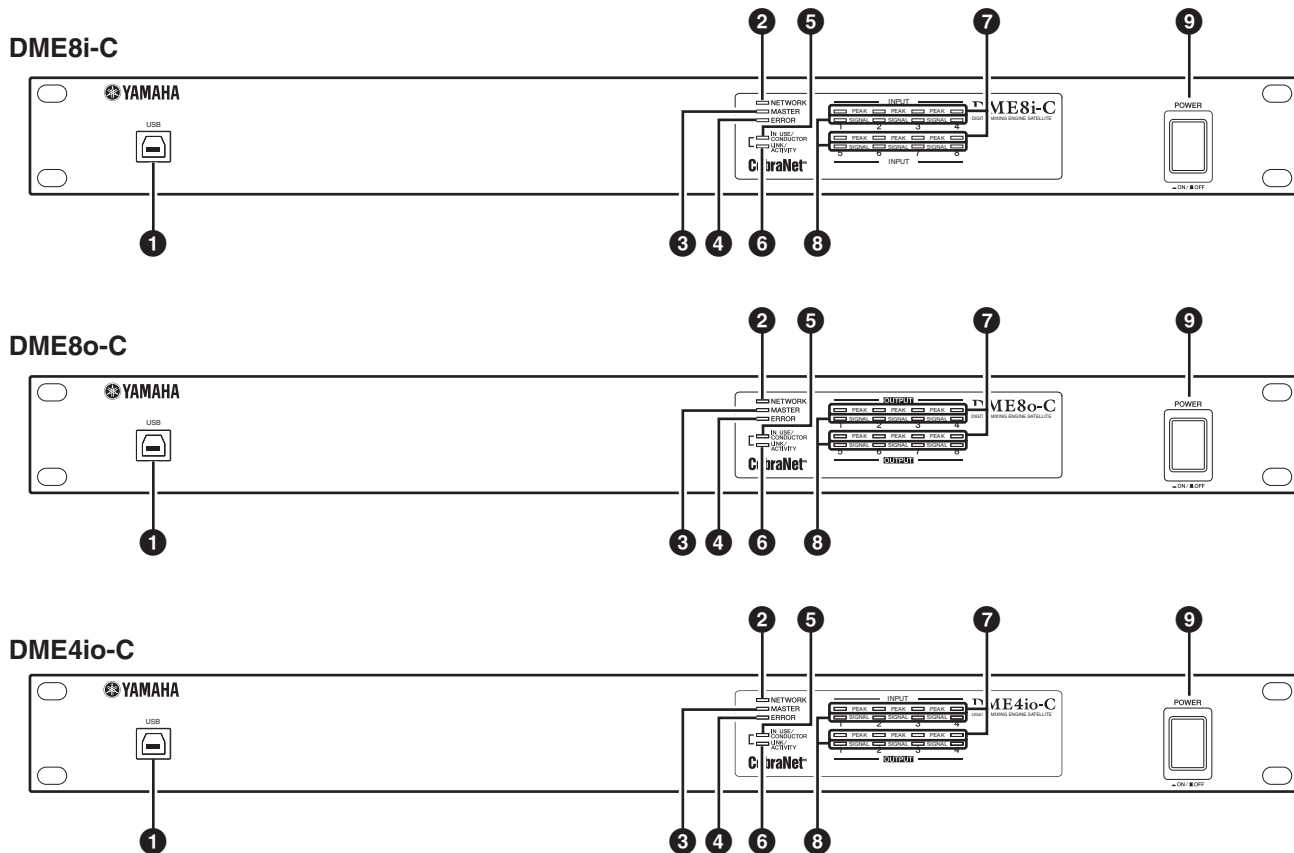

1 [USB] Connector

Use this connector to connect the DME Satellite to the computer's USB port. If you plan to use a USB connection, you must first install the USB-MIDI Driver on your computer. Refer to the "DME Setup Manual" (PDF file) for installation instructions.

Be sure to follow the procedure below when you make a USB connection with a computer. Otherwise, the computer and/or DME Satellite may freeze, resulting in damages or loss of data.

If the computer or DME Satellite freezes, turn the power to the DME Satellite off and then on, then restart the computer.

- Before you connect the DME Satellite to the computer via USB, cancel the computer's energy saving mode (such as Suspend, Sleep, or Stand-by mode).
- Before turning on the power to the DME Satellite, first connect its [USB] connector to the computer's USB port.
- Before turning the power to the unit on or off, and before connecting or disconnecting the USB cable, take the following actions:
 - Quit all open applications.
 - Make sure that the DME Satellite is NOT transferring any data.
- Be sure to wait six seconds or more between turning the power to the unit on and then off (or off and then on), or between connecting and disconnecting (or vice versa) the USB cable.



CAUTION

2 [NETWORK] Indicator

Lights orange while data communication is occurring via the [USB] or [NETWORK] connector.

3 [MASTER] Indicator

Lights green when the device is operating as the group master. The indicator is turned off if the device is operating as a slave.

You can assign the group master in DME Designer.

4 [ERROR] Indicator

Lights when an error occurs. The [PEAK] indicators reflect the type of error. The [ERROR] indicator flashes when the battery charge is getting low.

5 [IN USE/CONDUCTOR] Indicator

Lights orange when the power is supplied correctly to the DME Satellite. It flashes while the device is operating as a CobraNet conductor. If the secondary (backup) connector on the DME Satellite is connected (page 21), the indicator turns off every three seconds to indicate an abnormality on the primary connection.

NOTE

Refer to page 21 for information on the primary and secondary connectors.

6 [LINK/ACTIVITY] Indicator

Lights up steadily or flashes slowly when cables are connected correctly to the CobraNet connectors. It flashes rapidly while the unit is transferring data onto the network correctly. If the secondary (backup) connection is being used for communication, the indicator turns off every three seconds to indicate an abnormality on the primary connection.

7 [PEAK] Indicators

Light red when the signal level at the corresponding built-in analog audio inputs or outputs ([INPUT] or [OUTPUT] connectors) reaches or exceeds -3 dBFS. They also indicate an error number or status.

8 [SIGNAL] Indicators

Light green when the signal level at the corresponding built-in analog audio inputs or outputs ([INPUT] or [OUTPUT] connectors) reaches or exceeds -40 dBFS. They also indicate the status, for example, of the initialization process.

NOTE

Remove the transparent protective film that was applied to the indicator panel prior to shipment from the factory.

9 [POWER] Switch

Turns mains power to the device on and off. The DME Satellite will start up with the same scene settings that were active when it shut down. You can use the “Last Mem. Resume” setting in DME Designer to set up the DME Satellite so that at startup it will recall the scene selected before you turned off the power to the device.



- If “Last Mem. Resume” is set to ON, the unit will back up data to the internal memory periodically. In this case, do not turn off the power to the unit within five (5) seconds after you operate any parameters.

Caution when turning the power off

Do not turn off the power while the front panel [SIGNAL] indicators are lighting consecutively in the clockwise direction.

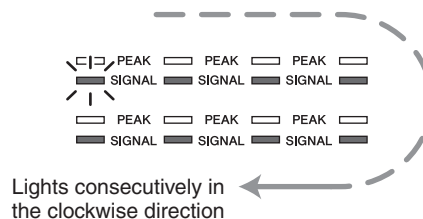

This indicates that data is being written into internal memory, and part of the data may be damaged if you turn off the power at this time. Data writing will occur during the following operations.

- While shifting to on-line operation
- While storing or deleting scene memory
- While saving changes to the Utility settings
- While using the DME File Storage function to transmit/receive or delete files
- While updating the firmware, or while reverting to the previous firmware following a failed update

Rear Panel

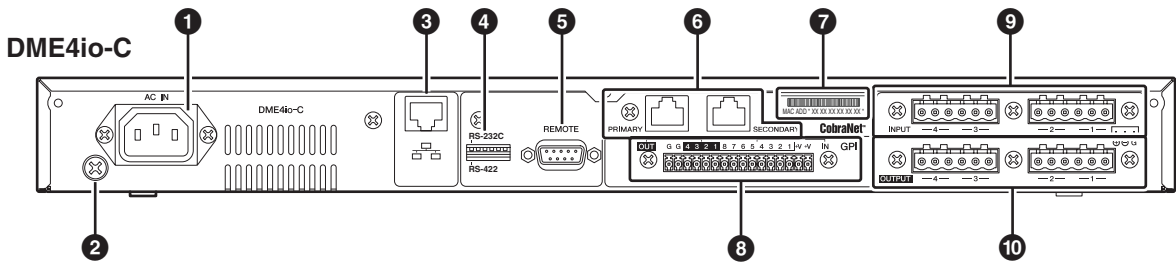
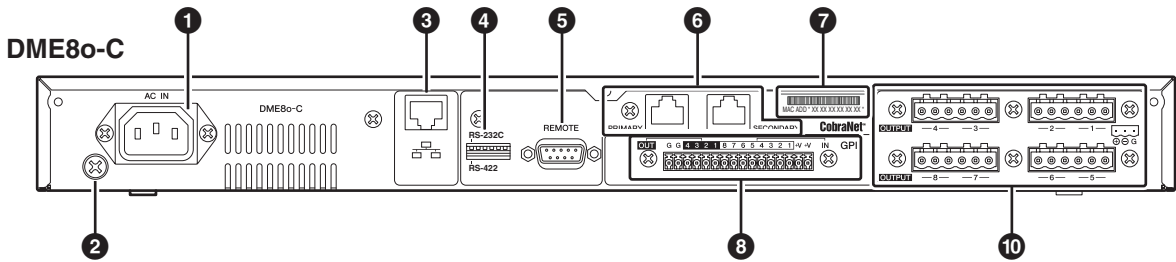
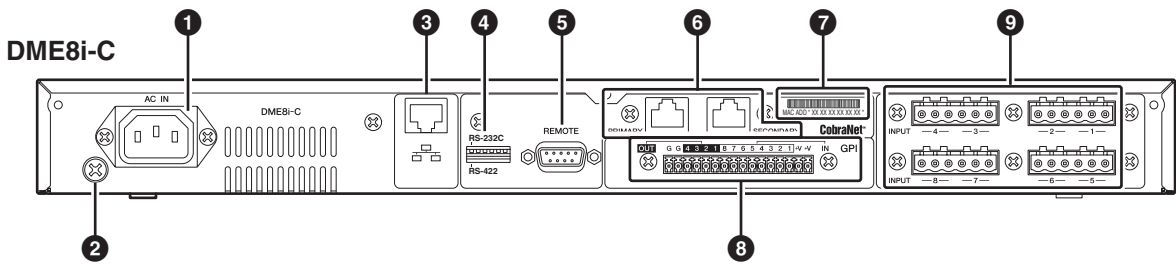

1 [AC IN] Connector

Connect to the AC mains using the supplied AC power cord. First connect the power cord to the DME Satellite, then insert the power cord plug into an AC outlet.



Even when the power switch is turned off, electricity is still flowing to the product all the minimum level. When you are not using the product for a long time, make sure to unplug the power cord from the wall AC outlet.

2 Ground Screw

For maximum safety be sure to securely connect the DME Satellite ground screw to an earth connection. The supplied power cable has a three-prong plug that will ground the unit when the plug is inserted into an appropriately grounded three-prong type AC mains outlet. If the AC outlet is not grounded, be sure to ground the unit by using this ground screw. Correct grounding will effectively eliminate hum noise and interference.

3 [NETWORK] Connector

This is a 100Base-TX/10Base-T Ethernet connector for connection to a computer or to another DME series unit in the network. See “Ethernet Connection ([NETWORK] Connector)” on page 24 for connection details.

NOTE

Use a STP (Shielded Twisted Pair) cable for this connection to prevent electromagnetic interference.

4 Dip Switch

This 6-bit dip switch enables you to select the [REMOTE] connector function or initialize the DME Satellite, depending on its setting at the startup of the device. To switch between RS-232C and RS-422 for the [REMOTE] connector function, turn off the power to the device, set the dip switch as shown below, then turn on the power to the device again. See page 35 for the DME Satellite initialization procedure.





If you do not plan to initialize the DME Satellite, set all dip switch bits (excluding one bit for the RS-422 setting) in the upper position.

5 [REMOTE] Connector

This 9-pin D-SUB connector allows connection to a Yamaha AD824 or AD8HR remote head amplifier or an RS-232C/RS-422 compatible controller such as those from AMX or Crestron. See “Remote Connection ([REMOTE] Connector)” on page 30 for connection details.

6 CobraNet [PRIMARY]/[SECONDARY] Connectors

The DME Satellite features two CobraNet connectors for built-in redundancy: one for a primary network connection, another for a secondary or backup connection. If for some reason the primary connection fails (e.g., a cable is damaged, inadvertently disconnected, or a switching hub fails), the secondary connection automatically kicks in. Audio transmission is momentarily interrupted, but the duration of interruption varies depending on the hub performance or settings, and the system configuration.

NOTE

- You can check the CobraNet connection status by looking at the [IN USE/CONDUCTOR] and [LINK ACTIVITY] indicators. The indicators on both sides to the CobraNet connectors are turned off.
- Use a STP (Shielded Twisted Pair) cable to prevent electromagnetic interference.

7 MAC Address

This is the CobraNet's MAC (Media Access Control) address.

8 [GPI] Connector

This Euroblock connector provides access to the unit's GPI (General Purpose Interface) interface for transfer of control signals to and from external equipment. It features 8-port input and 4-port output. The +V terminals have an output voltage of 5 volts. The IN terminal detects voltage changes from 0V to 5V. The OUT terminals output either signal "L" or "H" at a TTL level. (See page 34.)

9 [INPUT] Connectors

These Euroblock connectors receive 8-channel analog audio signals on the DME8i-C.

These Euroblock connectors receive 4-channel analog audio signals on the DME4io-C.

NOTE

- The PAD will be internally switched on or off when the gain of the DME8i-C/DME4io-C internal head amp is adjusted between -6 dB and -5 dB. Keep in mind that noise may be generated if there is a difference between the Hot and Cold output impedance of the external device connected to the INPUT connector when using phantom power.

10 [OUTPUT] Connectors

These Euroblock connectors output 8-channel analog audio signals on the DME8o-C.

These Euroblock connectors output 4-channel analog audio signals on the DME4io-C.

Connecting to a Computer

USB Connection

To connect multiple DME Satellite units to a network, you must assign appropriate IP addresses and make other network settings on all units. To achieve this, you need to connect the [USB] connector of one of the DME Satellite units to the USB port of the computer using USB cables, install USB-MIDI Driver and DME Designer on the computer, then assign the IP addresses to the DME Satellite units from DME Designer.

NOTE

- Refer to the “DME Setup Manual” (PDF file) for details on installing USB-MIDI Driver and DME Designer.
- Make sure that the USB-MIDI Driver’s THRU setting is “OFF.”
- Refer to “Network Settings” on page 23 for more information on assigning IP addresses from DME Designer.

USB connections can be used in the following three ways:

- (1) Set up the network (e.g., assign a unique IP address to each DME Satellite) from DME Designer.
- (2) Control the DME Satellite from DME Designer.
- (3) Connect to any individual DME Satellite and control that DME Satellite unit by transmitting MIDI commands from a MIDI sequencer or similar software.

NOTE

- When using a DME Satellite together with the DME64N/24N, you must assign the DME Satellite (including the DME8i-ES/DME8o-ES/DME4io-ES) as the master.
- The computer on which DME Designer is running can be connected to either the group master or a slave DME series unit.
- The correspondence between the MIDI commands to be received/transmitted and the scene parameters can be set up using DME Designer.
- The USB port being used by DME Designer is not available for use by a MIDI sequencer or other application.

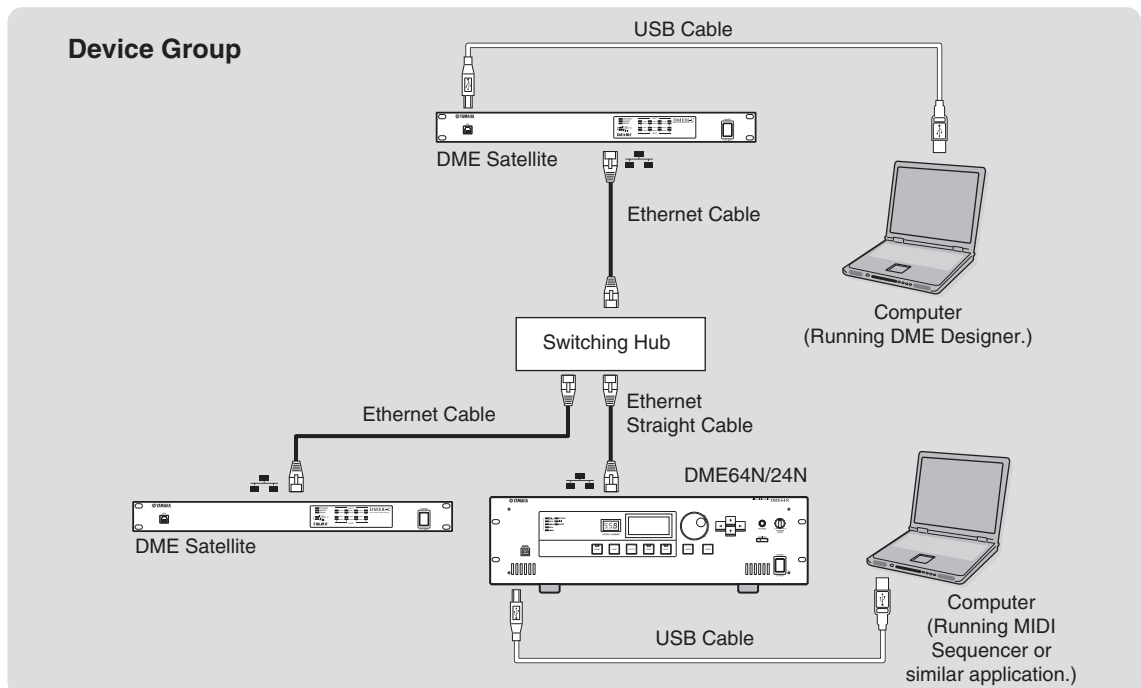

Network Settings

Use DME Designer to specify the IP address, master/slave, and master ID settings as follows.

Setting the IP address

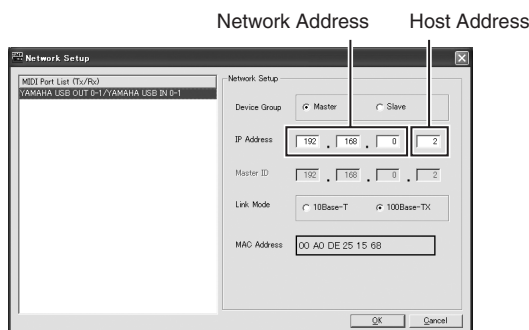

Each group of digits between periods in an IP address is called an “octet.” These groups of digits are called “1st octet,” “2nd octet,” etc., starting from the left-most digit group.

You cannot specify 0, 127, or 223 through 255 for the 1st octet of the network address.

You can specify the following range of values for the 4th octet.

Master : 2-253

Slave : 3-253

NOTE

- Subnet mask is fixed at 255.255.255.0.
- The network address of Gateway is the same as that of IP address. The host address of Gateway is automatically set to 254.
- Assign each of DME series units a unique IP address so that there are no duplicates. Assigning duplicate IP addresses may cause serious network problems.
- You cannot make any network settings while using the DME Designer application on-line. To make network settings, first set DME Designer off-line. Refer to the DME Designer Owner's Manual for details.
- If you have connected a PM5D and a DME Satellite via CobraNet and are controlling the DME Satellite from the PM5D, you must specify a value of 2 as the fourth octet of the group master DME Satellite's IP address. However, if the PM5D is version 2.20 or higher and the DME Satellite is version 3.07 or higher, you can set the parameter to any number.

Master and slave setting

Each device group must have one master. All other devices in the group are assigned as slave.

The fourth octet of a slave DME Satellite's master ID must be the same value as the fourth octet of the group master DME Satellite's IP address.

NOTE

When using a DME Satellite together with the DME64N/24N, you must assign the DME Satellite (including the DME8i-ES/DME8o-ES/DME4io-ES) as the master. If you assign the DME64N/24N as the device group master, you will be unable to synchronize using DME Designer.

Ethernet Connection ([NETWORK] Connector)

To control the DME Satellite from the computer via Ethernet, use an Ethernet cable to connect the [NETWORK] connector on the rear panel of the DME Satellite to the computer, then install DME-N Network Driver.

NOTE

- Refer to the “DME Setup Manual” (PDF file) for details on installing DME-N Network Driver.
- Appropriate IP addresses must first be assigned to all devices connected to an Ethernet network. Connect your computer to one of the DME Satellite units via USB, then assign the IP addresses from DME Designer (page 22).

Two DME Satellite units directly connected via Ethernet

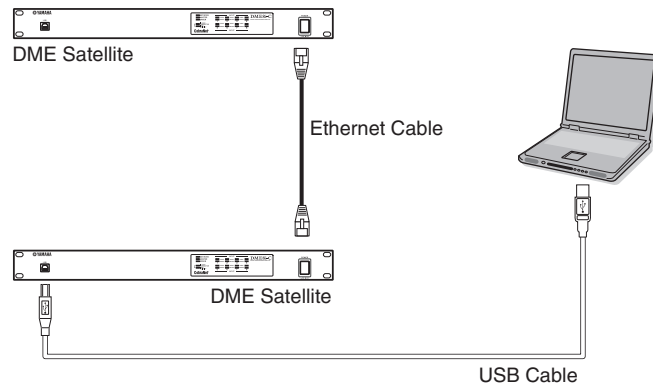

You can connect devices in the same device group directly to each other using Ethernet cables, without connecting them to a switching hub. If they are DME Satellite units, you can use either crossover cables or straight cables. In this case, from DME Designer set Link Mode on both units to the same setting. Devices in different subnet (different network address) groups can be connected via a router or layer-3 compliant switching hub.

HINT

Since the DME Satellite supports Auto MDI/MDI-X, it will automatically detect whether the connected cable is of the straight type or crossover type, and will configure itself to create the optimal connection. Therefore, you can use either a straight or crossover cable.

Control from a computer in the same subnet group

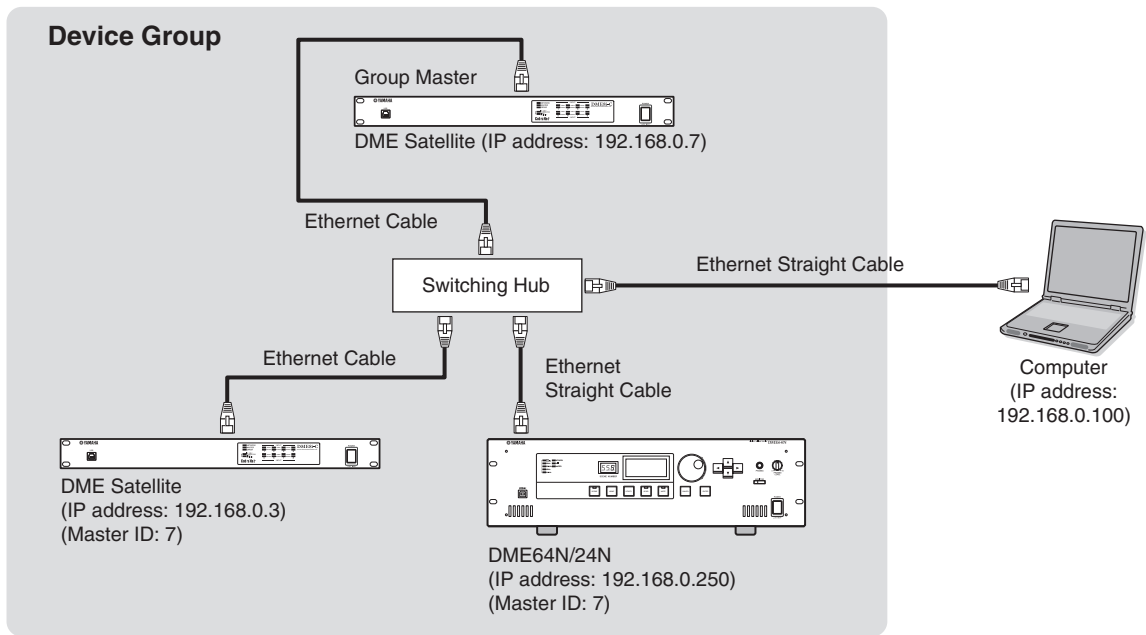
**NOTE**

- The IP addresses in the diagram are examples.
- Use a switching hub that is compatible with 100Base-TX/10Base-T network speeds.
The maximum length of a cable between a switching hub and the DME Satellite is 100 meters. Due to the quality of cables and switching hub performance, however, proper operation at the maximum length cannot be guaranteed in some cases. Use a STP (Shielded Twisted Pair) cable to prevent electromagnetic interference.
- If you are using multiple DME series units, set Link Mode on each unit to the same setting. Yamaha recommends that you select 100Base-TX for the Link Mode setting.
- You can also connect a supported controller such as the AMX or Crestron, and control the DME Satellite remotely. For details, refer to “Connecting to an External Device” on page 30.

Control from a computer with a different subnet

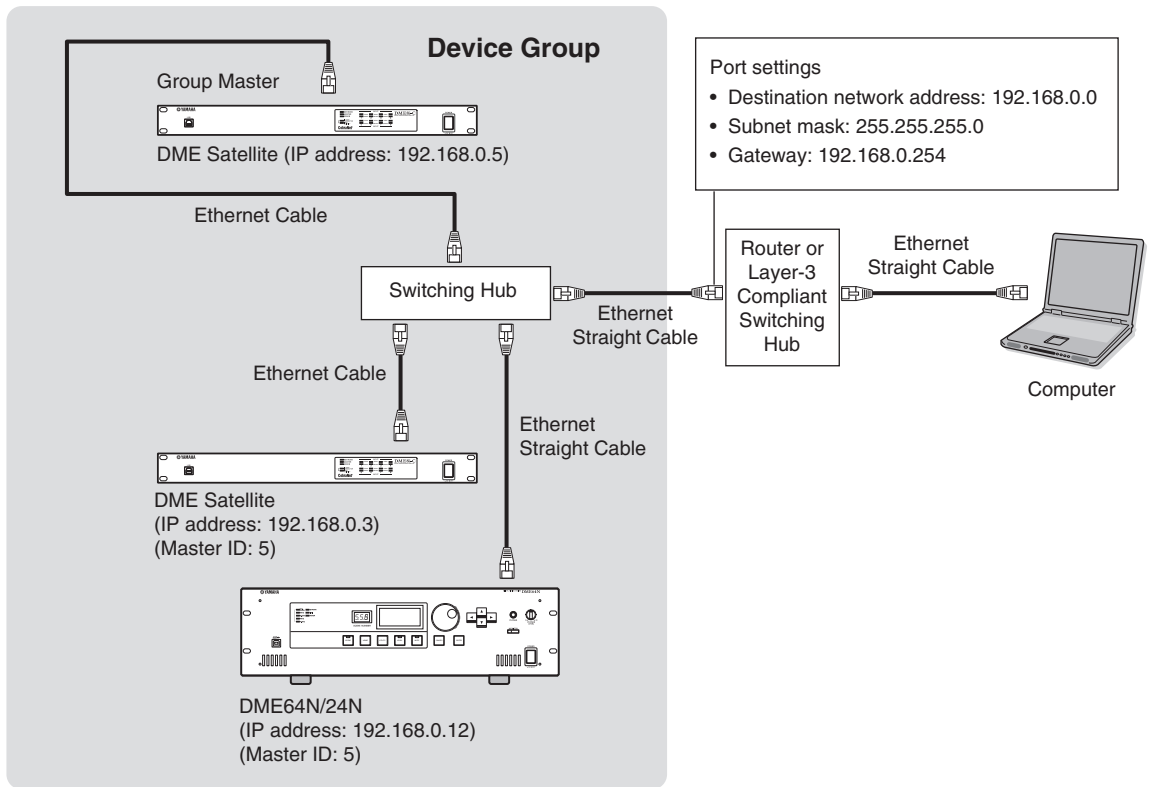

Connecting multiple device groups

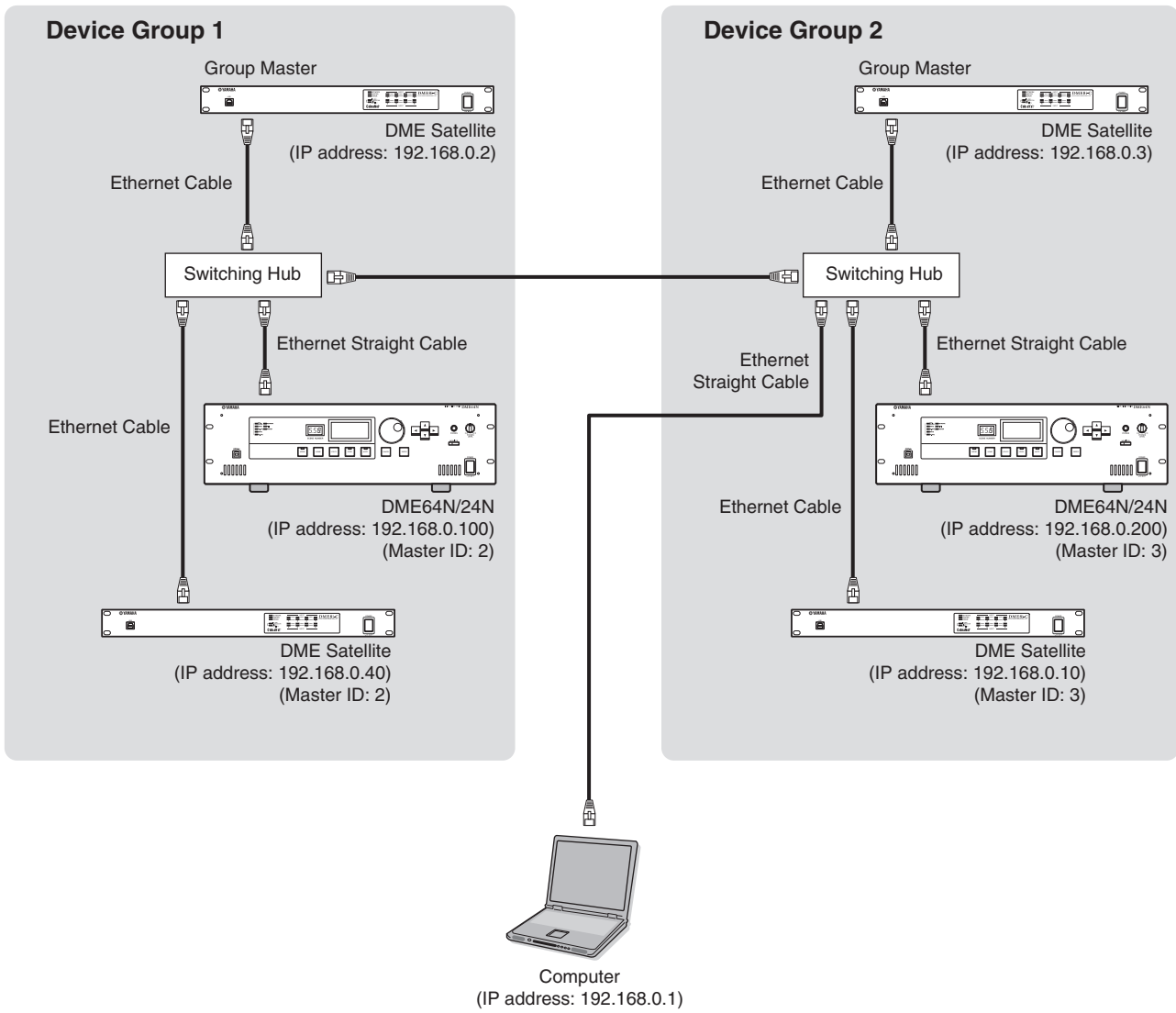

Audio I/O Connection

Digital Audio Connection (CobraNet Connectors)

The DME Satellite CobraNet connectors enable you to transfer digital audio, control, and word clock signals. Refer to page 15 for more information on CobraNet.

Connecting and setting up the DME Satellite in accordance with other CobraNet compatible equipment allows for broad-ranging audio and word clock signal networkability. Refer to the MY16-C or MY16-CII Owner's Manual for more information on the corresponding interface card.

Example: Connection to CobraNet devices

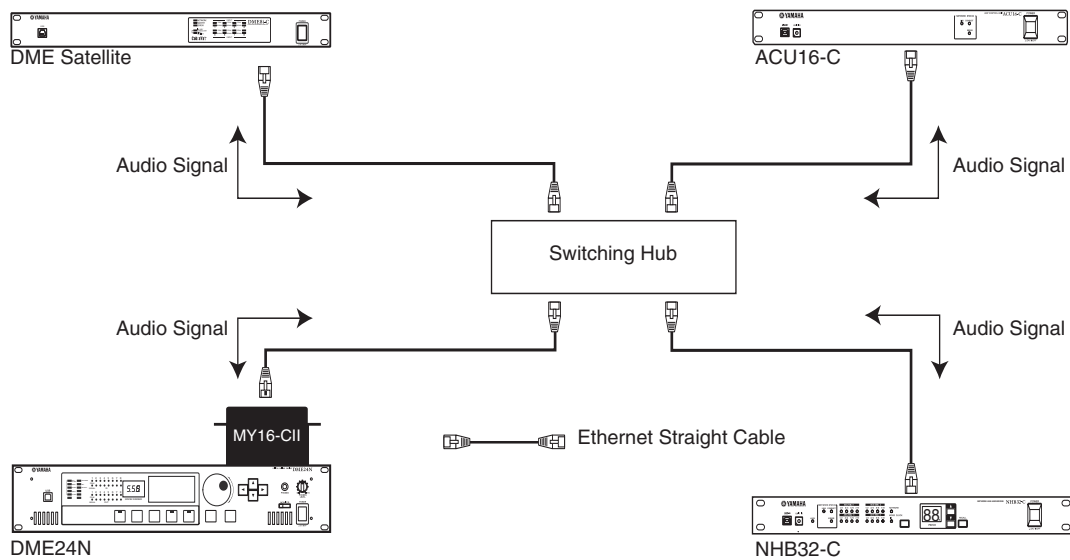

NOTE

DME Satellites and the MY16-C or MY16-CII can transmit and receive control data such as for internal head amps via CobraNet. However in some cases, it may not be possible to transmit or receive control data depending on the device in which the MY card is installed. For details, refer to the operating manual of the device in which the card is installed.

Analog Audio Connection ([INPUT] & [OUTPUT] Connectors)

The DME Satellite can directly input and output audio signals via the [INPUT] and [OUTPUT] connectors. Wire the supplied Euroblock plugs (3P) as shown below. You can use DME Designer to set the head amplifier gain and turn the phantom power on and off for each [INPUT] connector.

Cable preparation

Prepare cables to be attached to a Euroblock plug as shown below.

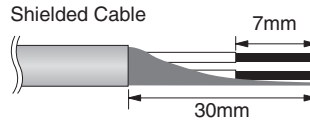

Be sure to use shielded cables.



Do not tin (plate with solder) the exposed sections of the cable.

Euroblock plug connection

NOTE

Use a slotted screwdriver with a blade width of about 3 millimeters to secure the cables to the (3P) Euroblock plug.
Use a slotted screwdriver with a blade width of about 2 millimeters to secure the cables to the (16P) Euroblock plug to connect to the [GPI] connector.



1. Loosen terminal screws.

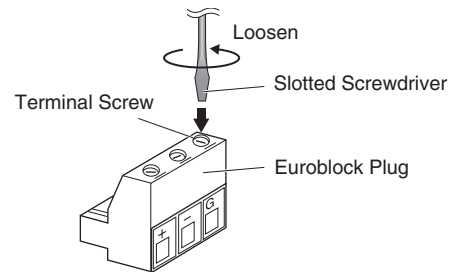

2. Insert cables.

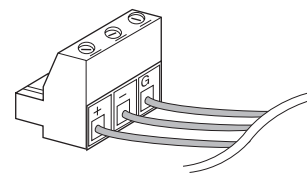

3. Securely tighten terminal screws.

Pull the cables (not too strongly) to confirm that they are securely connected.

4. Insert the Euroblock plug into the Euroblock connector on the rear panel.

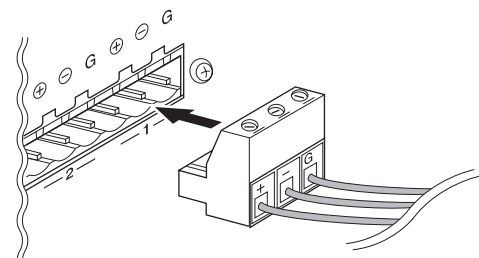

Connecting to an External Device

Remote Connection ([REMOTE] Connector)

The [REMOTE] connector of the DME Satellite can be connected to remotely-controllable Yamaha AD8HR or AD824 head amplifiers (pre-amps), digital mixers, or RS-232C compatible controllers (such as those from AMX or Crestron). The [REMOTE] connector also transmits and receives MIDI messages.

Controlling external head amplifiers from the DME Satellite

You can remotely control the AD8HR or AD824 head amplifier settings from DME Designer. Up to eight AD8HR/AD824 head amplifiers can be connected.

Be sure to set the dip switch on the rear panel of the DME Satellite to “RS-422” (page 20) when connecting to AD8HR or AD824 remote head amplifiers. Do not change the dip switch setting to any position other than to “RS-422” while the devices are connected to prevent possible damage to the device(s).

When connecting to a combination of AD8HR and AD824 head amplifiers, be sure to place the AD8HR units closest to the DME Satellite in the chain, otherwise the AD8HR or AD824 unit(s) may not be properly recognized by the DME Satellite.

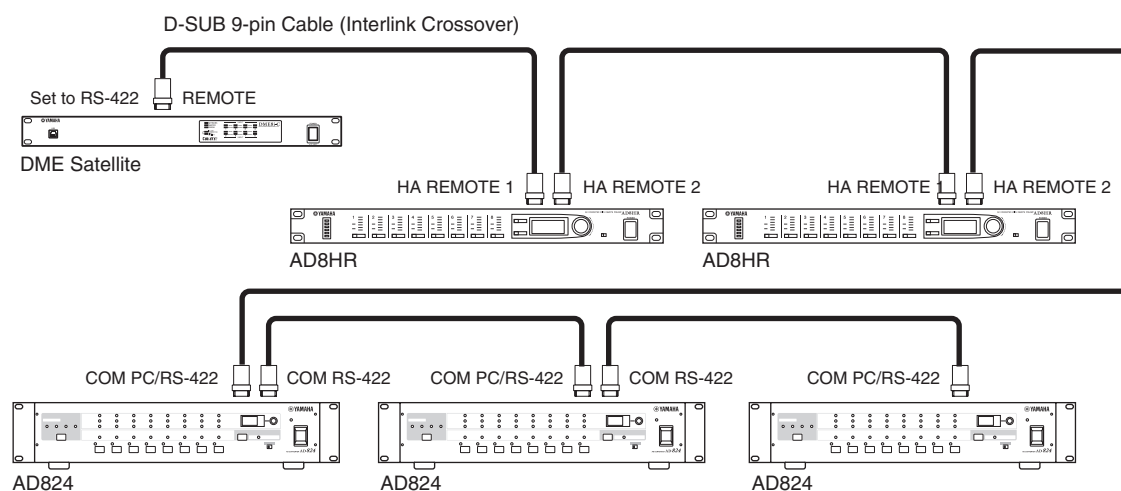

NOTE

Only control signals are transmitted and received via the REMOTE connection. Audio connections must be made separately.

Controlling a DME Satellite's internal head amps from a digital mixer

The internal head amp settings of a DME8i-C or DME4io-C can be remotely controlled from a digital mixer such as the Yamaha PM5D or DM2000.

Connect the digital mixer to the DME series' [REMOTE] connector, and use an Ethernet cable to make connections between the [NETWORK] connectors of the DME series.

From the digital mixer, DME series units can be controlled as an AD8HR. The gain and the phantom power (+48V) can be controlled.

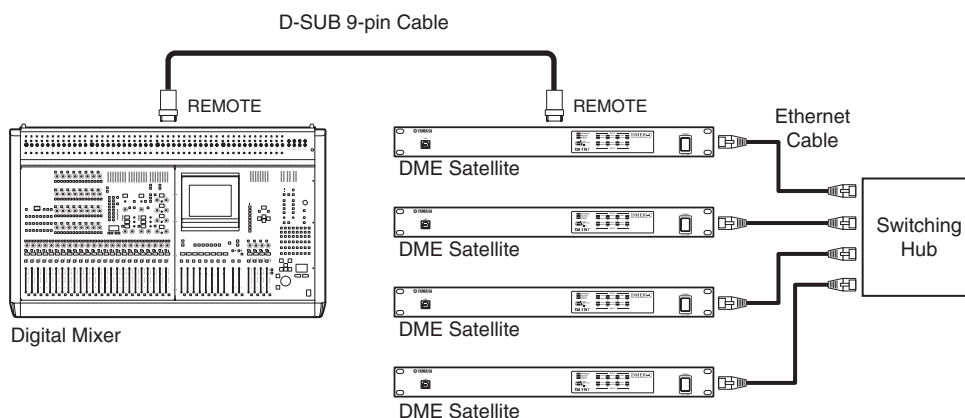

NOTE

- Only one mixer can be connected within each device group.
- The digital mixer can be connected to any DME series unit, whether it is the group master or a slave unit.
- The ID number of the DME series unit being remotely controlled is specified from DME Designer. For details on making this setting, refer to the "DME Designer Owner's Manual."
- If the connection between DME series units is broken, it will no longer be possible to communicate with DME units of an ID number that follows the disconnected DME.
- The variable range of GAIN differs between the AD8HR and the DME Satellite. You cannot use the mixer to specify a value that exceeds the variable range of the DME Satellite.

Controlling the DME Satellite from an external device

You can remotely control the DME Satellite from a connected RS-232C or RS-422 compatible controller, such as those from AMX or Crestron.

Be sure to set the dip switch on the rear panel of the DME Satellite correctly (page 20) in accordance with a connected RS-232C or RS-422 compatible remote controller. Do not change the dip switch setting to any other position while the devices are connected to prevent possible damage to the device(s).

NOTE

- The port used for remote control is specified from DME Designer. For details on making this setting, refer to the "DME Designer Owner's Manual."
- Refer to "DME Remote Control Protocol Specifications" on the Yamaha web site for more information on communication protocols used to control the DME Satellite from an external device (such as those from AMX or Crestron).
<http://www.yamahaproaudio.com/>

CobraNet Connection (CobraNet Connectors)

You can use the CobraNet connector to control the DME Satellite's internal head amp or other functionality.

Controlling DME Satellite's internal head amps from a digital mixer Yamaha LS9

The internal head amp settings of a DME8i-C or DME4io-C can be remotely controlled from a digital mixer LS9. Use the MY16-CII interface card to make CobraNet connections between the digital mixer and the DME series. Use an Ethernet cable connected to the [NETWORK] connectors to make connections between DME series units.

The gain and the phantom power (+48V) can be controlled from the digital mixer.

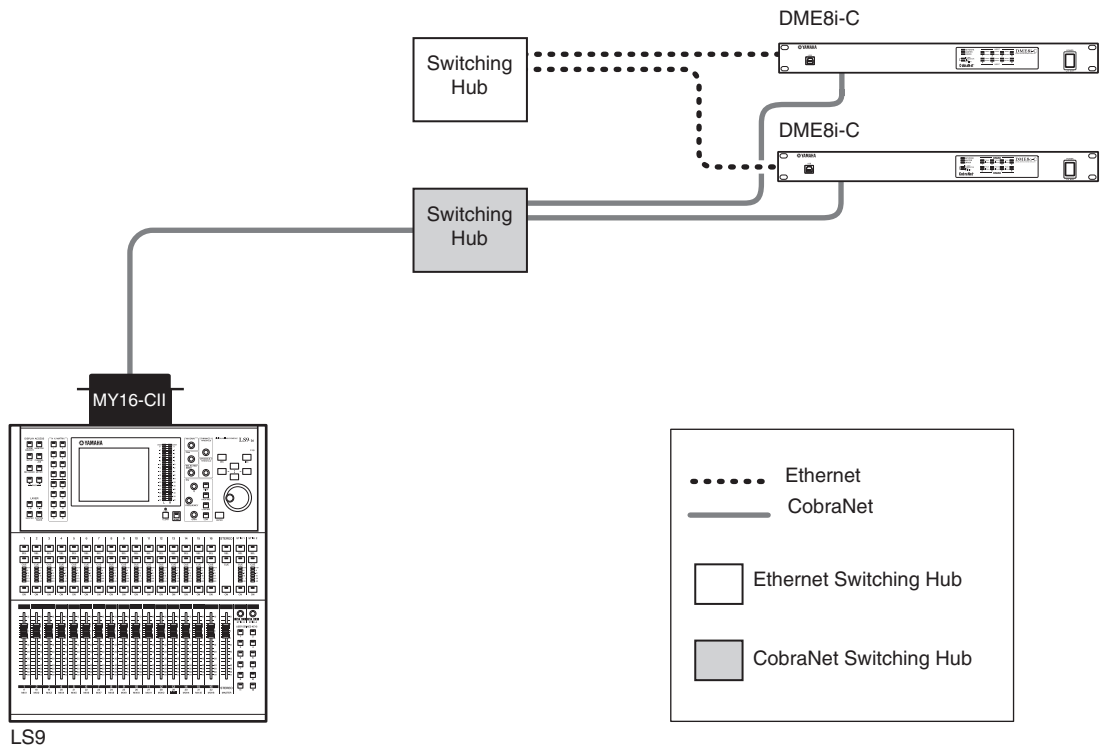

NOTE

- Only one mixer can be connected within each device group.
- The digital mixer can be connected to any DME series unit, whether it is the group master or a slave unit.
- The ID number of the DME series unit being remotely controlled is specified from DME Designer. For details on making this setting, refer to the “DME Designer Owner’s Manual.”
- If the connection between DME series units is broken, it will no longer be possible to communicate with DME units of an ID number that follows the disconnected DME.

Controlling the DME Satellite from a digital mixer Yamaha PM5D

If you install an MY16-C or MY16-CII interface card on a PM5D Digital Mixing Console and connect it to the DME Satellite via the CobraNet connectors, you can remotely control the DME Satellite from the PM5D, as well as transfer audio and word clock signals between them. Refer to the PM5D/PM5D-RH Owner's Manual for more information on the PM5D's DME Control function.

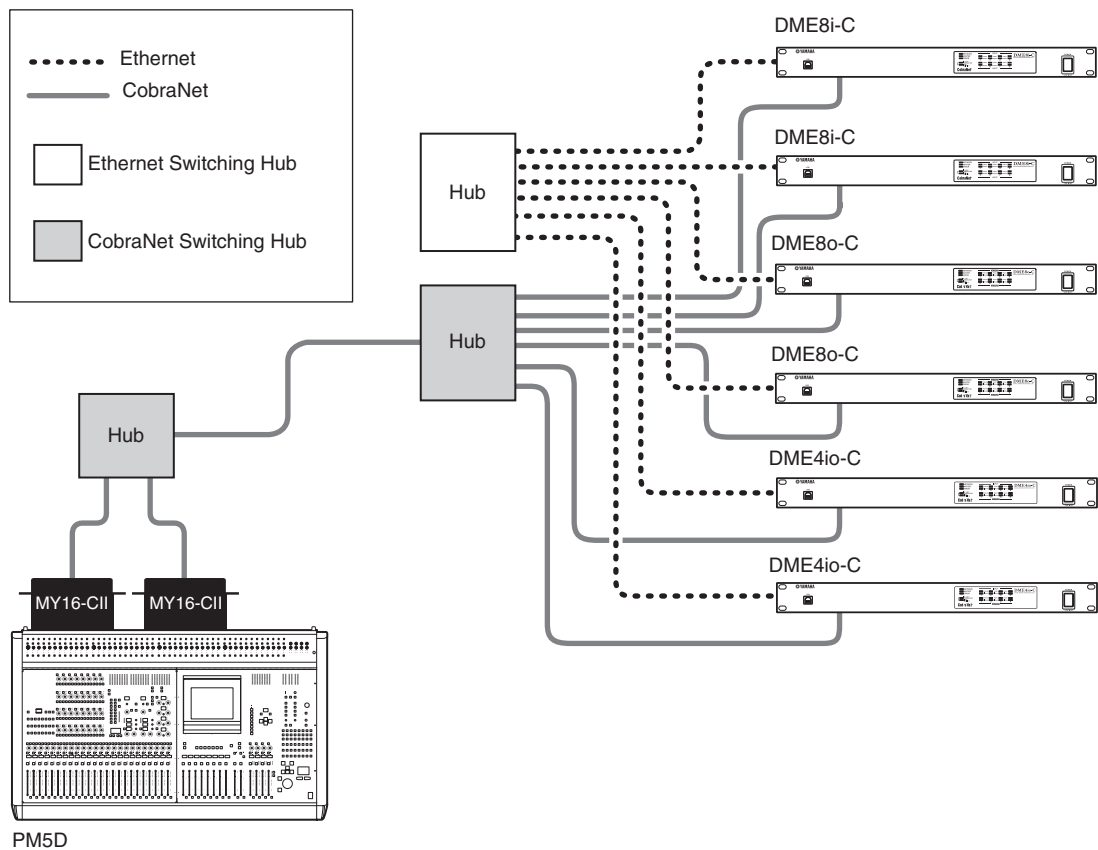

NOTE

- You can control multiple DME series units from a PM5D. Specify the same device group for each DME series unit you want to control.
- If you have connected a PM5D and a DME Satellite via CobraNet and are controlling the DME Satellite from the PM5D, you must specify a value of 2 as the fourth octet of the group master DME Satellite's IP address.

Network Connection ([NETWORK] Connectors)

You can connect a controller such as the AMX or Crestron to DME Satellites via Ethernet, and remotely control multiple DME Satellite units.

NOTE

- The port used for remote control is specified from DME Designer. For details on making this setting, refer to the "DME Designer Owner's Manual."
- Refer to "DME Remote Control Protocol Specifications" on the Yamaha web site for more information on communication protocols used to control the DME Satellite from an external device (such as those from AMX or Crestron).
<http://www.yamahaproaudio.com/>

GPI Connection ([GPI] Connector)

A GPI (General Purpose Interface) device (GPI controller, etc.) can be connected to the rear panel [GPI] connectors to enable the transfer of a variety of control signals. Optional CP4SW, CP4SF, and CP1SF Control Panels can be also connected via GPI.

The DME Satellite features 8-port GPI input and 4-port GPI output. The +V terminals have an output voltage of 5 volts. The IN terminal detects voltage changes from 0V to 5V. The OUT terminals output either signal “L” or “H” at a TTL level.

The parameters for each GPI input and output are assigned via the DME Designer application.

Euroblock connectors are used for all GPI input and output connections. Euroblock connection methods are described in “Euroblock plug connection” on page 29 in this manual.

NOTE

- For more information on the CP4SW, CP4SF, and CP1SF Control Panels, refer to the CP4SW/CP4SF/ CP1SF Owner’s Manual.
- You can use DME Designer to set up the system so that scene recall operations and User Defined parameter control can be carried out from connected GPI control devices. Refer to the DME Designer Owner’s Manual for details.

Example: Controlling the DME Satellite from a switch box

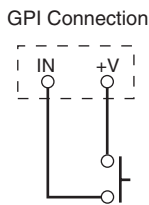

Example: Controlling the DME Satellite via a 10k ohm linear taper potentiometer.

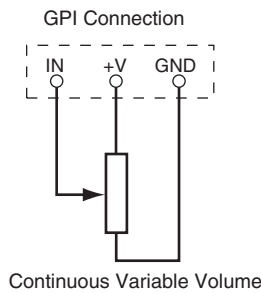

Example: Lighting LED indicators on the external devices from the DME Satellite

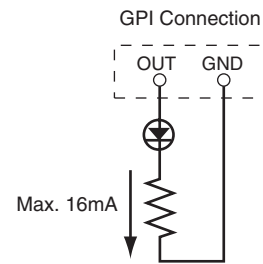

Make sure that the current between the OUT and GND [GPI] connectors is less than 16mA.

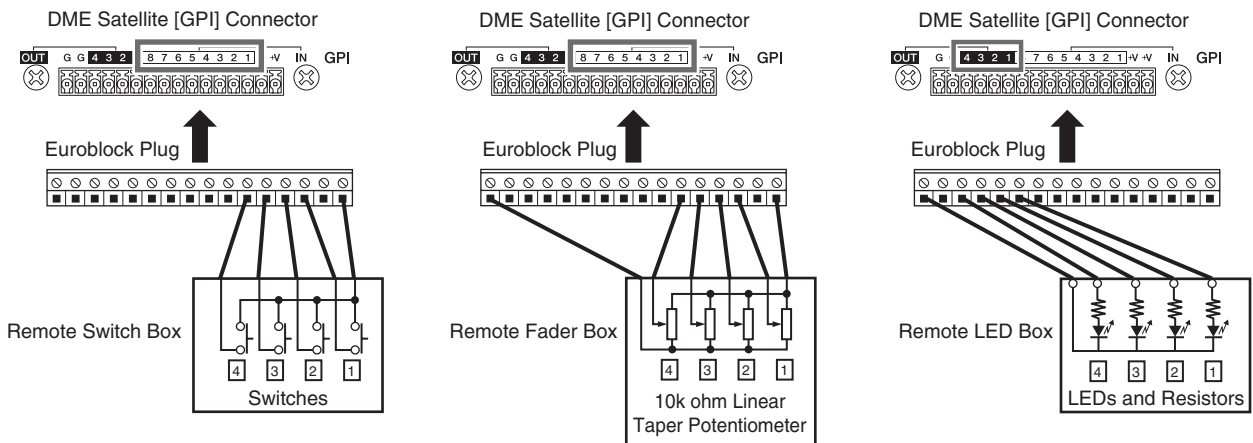

NOTE

You can use DME Designer to adjust the input calibration parameters for the [GPI] connector.

Initializing the DME Satellite

You can initialize the DME Satellite internal memory.

Select one of the following initialization types:

Initialize DME:

All scenes, preset parameter settings and WAVE files except components and files saved via the File Storage function will be deleted. The Utility settings will be set to default values.

Delete All Data:

All stored component, scene, and preset parameter settings, WAVE files, and files saved via the File Storage function will be deleted. The Utility settings will be set to default. Use this initialization type if the internal data is damaged or corrupted. After initialization, transfer necessary components from DME Designer.

- 1. While the DME Satellite is turned off, set the dip switch on the rear panel to the following position, then turn on the power to the unit.**



Four [PEAK] indicators on the upper row on the front panel light up during the initialization process. Four [SIGNAL] indicators on the lower row of the front panel flash when the initialization process is complete. Four [PEAK] indicators on the lower row of the front panel flash if the initialization process fails.



Do NOT turn off the power to the DME Satellite during the initialization process to prevent possible damage to the device.

- 2. When initialization is complete, reset the dip switch to its previous position (page 20), then turn off and on the power to the unit.**



Be sure to reset the dip switch to the previous position to prevent possible damage to the device.

References

Options

The ICP1, CP4SW, CP1SF, and CP4SF controllers are available as options for remote external control of the DME series. The ICP1 connects via Ethernet, while the CP4SW, CP1SF, and CP4SF connect via the GPI interface. For more information on installing your Control Panel and connecting it to a DME series unit, refer to the owner's manual that came with the Control Panel. For more information on settings, refer to the DME Designer Owner's Manual.

ICP1

This controller connects to a DME series unit via Ethernet. Like the DME series units, a unique IP address must be assigned to each controller unit. Data is transmitted and received via Ethernet cables.

You can assign and control any function of all DME series units in the same device group via the controller.

Up to four parameter sets can be assigned to six function keys (F1 – F6) located above and under the LCD. You can control up to 24 parameters by selecting a display page using the [HOME] key.

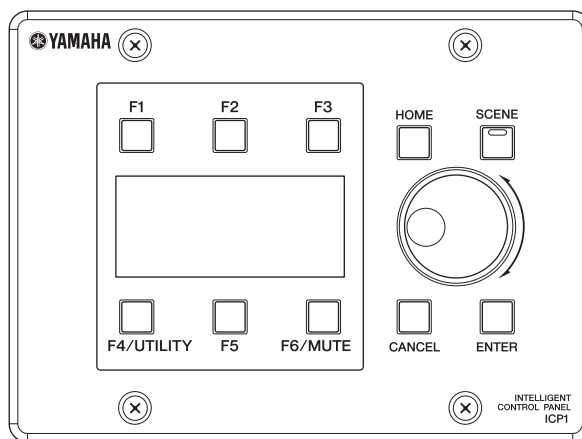

CP4SW, CP4SF, and CP1SF

These controllers connect to DME series units via the [GPI] connectors. These controllers control only the DME series units to which they are directly connected. The controller switches enable you to turn the parameter settings On and Off. The switch LEDs enable you to check the parameter status. The faders enable you to control the parameter values.

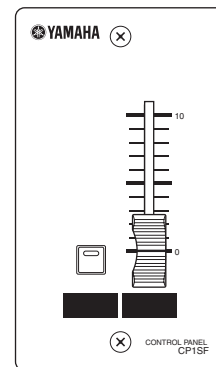
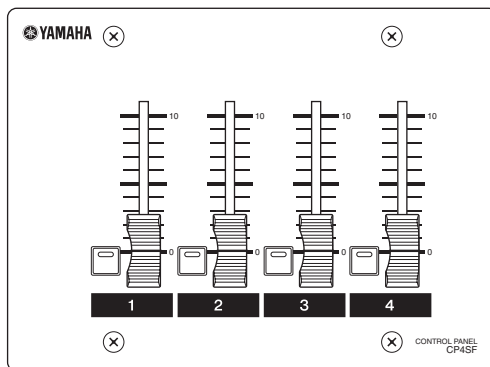
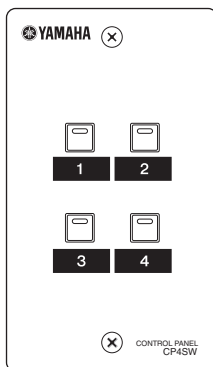

Troubleshooting

The device does not turn on, or the panel LEDs do not light up.	<ul style="list-style-type: none"> • Connect the power cord properly (page 7). • Make sure that the [POWER] switch is turned ON (page 19). • If the device still does not turn on, contact a Yamaha dealer.
No communication between the DME Satellite and the DME Designer application software.	<ul style="list-style-type: none"> • Connect the cable properly (page 22, 24). • Make sure that USB-MIDI Driver has been installed correctly. • If the [NETWORK] connector is being used for connection, make sure that you have set the DME-N Network Driver correctly. • Make the "MIDI Setup" settings. • The DME Designer version should be 3.0 or later. • Make the Port setting.
No audio input is present.	<ul style="list-style-type: none"> • Connect the cable properly. • Check to see if signals are being received from an external device. • Make sure that the CobraNet bundle and latency settings are correct. • Set the gain of the internal head amplifier or external head amplifier to an appropriate level.
No audio is output.	<ul style="list-style-type: none"> • Connect the cable properly. • Make sure that the CobraNet bundle and latency settings are correct. • Make sure that the number of CobraNet multicast bundles is not exceeding the recommended maximum number. • Depending on the type of switching hub and connection method, extra network resources may have been used, resulting in interruption of audio signals. • Make sure that the output level set in DME Designer is not too low. • Make sure that the Mute setting in DME Designer is set to Off. • You may have designed a scene in DME Designer that mutes audio output. • You may have tried to use a configuration at 96 kHz that does not support 96 kHz.
The selected scene changes unexpectedly.	<ul style="list-style-type: none"> • Use DME Designer to check the MIDI Program Change assignments. • Use DME Designer to check the GPI input assignments.
MIDI messages cannot be transmitted or received.	<ul style="list-style-type: none"> • Make sure that the power to the MIDI device is turned on. • Set the MIDI port properly. • Set the receive and transmit channels properly.
Scenes cannot be recalled via MIDI Program Change messages.	<ul style="list-style-type: none"> • Use DME Designer to change the setting so that the required MIDI Program Change messages will be received properly. • Make the appropriate Program Change Table settings via DME Designer.
Parameters cannot be controlled via MIDI Control Change messages.	<ul style="list-style-type: none"> • Use DME Designer to set the parameters correctly to allow Control Change message reception. • Make the appropriate MIDI Control Change Table settings via DME Designer.
Parameters cannot be edited via MIDI Parameter Change messages.	<ul style="list-style-type: none"> • Use DME Designer to set the parameters correctly to allow Parameter Change message reception. • Make the appropriate MIDI Parameter Change Table settings via DME Designer.

Component

Refer to the DME Designer Owner's Manual for more information on each component.

MIDI Data Format

1. MIDI functions on the DME8i-C, DME8o-C, and DME4io-C

1.1 Scene Change

Scene recall occurs according to the “MIDI Program Change Table” assignments when appropriate MIDI Bank Select MSB/LSB and Program Change messages are received by the DME8i-C/DME8o-C/DME4io-C.

When a scene recall operation is carried out via DME Designer, corresponding MIDI Bank Select MSB/LSB and Program Change messages are also transmitted by the DME8i-C/DME8o-C/DME4io-C as specified by the “MIDI Program Change Table” assignments.

Transmission does not occur while configurations are being switched.

1.2 Parameter Control

MIDI Control Change and Parameter Change messages transmitted to the DME8i-C/DME8o-C/DME4io-C can be used to control parameters according to the “MIDI Control Change Table” and “MIDI Parameter Change Table” assignments.

When a parameter is edited via DME Designer, corresponding MIDI Control Change and Parameter Change messages are also transmitted by the DME8i-C/DME8o-C/DME4io-C as specified by the “MIDI Control Change Table” and “MIDI Parameter Change Table” assignments.

“MIDI Program Change Table,” “MIDI Control Change Table,” and “MIDI Parameter Change Table” assignments can be made via DME Designer. Refer to the DME Designer Owner’s Manual for details.

2. MIDI Data Flow

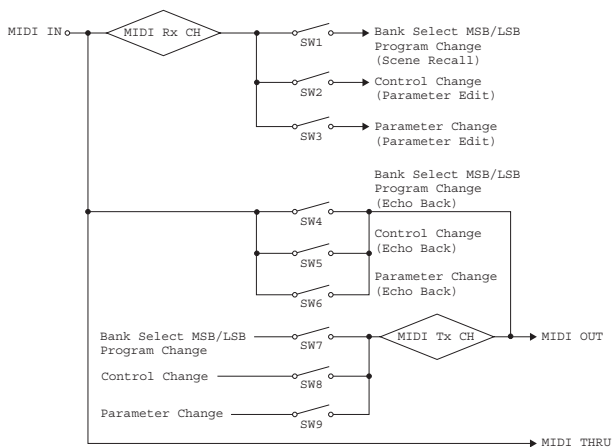

SW1:	Program Change Rx Switch [On/Off]
SW2:	Control Change Rx Switch [On/Off]
SW3:	Parameter Change Rx Switch [On/Off]
SW4:	Program Change Echo Back Switch [On/Off]
SW5:	Control Change Echo Back Switch [On/Off]
SW6:	Parameter Change Echo Back Switch [On/Off]
SW7:	Program Change Tx Switch [On/Off]
SW8:	Control Change Tx Switch [On/Off]
SW9:	Parameter Change
MIDI Rx CH:	MIDI Rx Channel (1-16)
MIDI Tx CH:	MIDI Tx Channel (1-16)

3. MIDI Setup

Specifies basic MIDI operation. Use DME Designer to make the setting.

3.1 Host Select

Selects the input/output ports to be used for MIDI communication.

3.2 MIDI Tx Channel

Specifies the MIDI transmit channel (1 ~ 16).

3.3 MIDI Rx Channel

Specifies the MIDI receive channel (1 ~ 16).

3.4 MIDI Tx Switch

Program Change Tx Switch: turns Bank Select MSB, LSB, and Program Change transmission on or off.

Control Change Tx Switch: turns Control Change transmission on or off.

Parameter Change Tx Switch: turns Parameter Change transmission on or off.

3.5 MIDI Rx Switch

Program Change Rx Switch: turns Bank Select MSB, LSB, and Program Change reception on or off.

Control Change Rx Switch: turns Control Change reception on or off.

Parameter Change Rx Switch: turns Parameter Change reception on or off.

3.6 MIDI Omni Switch

Program Change Omni Switch: turns the Bank Select MSB, LSB, and Program Change omni mode on or off.

Control Change Omni Switch: turns the Control Change omni mode on or off.

3.7 MIDI Echo Back Switch

Program Change Echo Back Switch: turns Bank Select MSB, LSB, and Program Change echo back on or off.

Control Change Echo Back Switch: turns Control Change echo back on or off.

Parameter Change Echo Back Switch: turns Parameter Change echo back on or off.

4. MIDI Format

Number Format Notation

Numbers ending with "h" are in hexadecimal format, while numbers ending with "b" are binary format. Characters "A" through "F" in hexadecimal numbers represent decimal values 10 through 15. Other lower-case characters (usually "n" or "x") can represent any number.

MIDI Format Chart (Rx: receive, Tx: transmit)

	Command	Rx/Tx	Function
Channel Message	Control Change (Bnh)	Rx/Tx	Editing the parameters
	Program Change (Cnn)	Rx/Tx	Scene Recall
System Real-time Message	TIMING CLOCK (F8h)	Rx	MIDI Clock Receive
	ACTIVE SENSING (FEh)	Rx	MIDI Cable Check
System Exclusive Message	Parameter Change	Rx/Tx	Editing the parameters

4.1 Program Change (Cnh)

Receive

When the "Program Change Rx Switch" is on, Program Change messages are received on the MIDI channel specified by the "MIDI Rx Channel" parameter.

If the "Program Change Omni Switch" is also on, however, Program Change messages will be received on all MIDI channels regardless of the "MIDI Rx Channel" setting.

When a Program Change message is received, the scene assigned to the received program number in the "MIDI Program Change Table" is recalled.

The effective Bank Select, Program Change range is as follows:

Bank Select MSB:	0
Bank Select LSB:	0-7
Program Change No.:	0-127

Transmit

When the "Program Change Tx Switch" is on and a scene is switched from DME Designer, the corresponding Program Change number will be transmitted as specified by the "MIDI Program Change Table" and "MIDI Tx Channel" settings.

If multiple Program Change numbers are assigned to a single scene, the Bank Select MSB/LSB and Program Change number corresponding to the lowest number will be transmitted.

Bank Select MSB

Status	Bnh (1101nnnnb)	Control Change
Data	00h (00000000b)	Control Change No. 0 (Bank Select MSB)
Data	nnh (0nnnnnnnb)	Control Value (Bank Select MSB No.)

Bank Select LSB

Status	Bnh (1101nnnnb)	Control Change
Data	20h (00100000b)	Control Change No. 32 (Bank Select LSB)
	nnh (0nnnnnnnb)	Control Value (Bank Select LSB No.)

Program Change No.

Status	Cnh (1100nnnnb)	Program Change
Data	nnh (0nnnnnnnb)	Program Change No. (0-127)

4.2 Active Sensing (FEh)

Receive

MIDI communication will be initialized if no data is received within 300 ms after reception (Running Status, etc., will be cleared).

Active Sensing

Status	FEh (11111110b)	Active Sensing
--------	-----------------	----------------

4.3 Control Change (Bnh)

Receive

When the "Control Change Rx Switch" is on, Control Change messages are received on the MIDI channel specified by the "MIDI Rx Channel" parameter.

If the "Control Change Omni Switch" is also on, however, Control Change messages will be received on all MIDI channels regardless of the "MIDI Rx Channel" setting.

Control Change parameter resolution is 128 regardless of the effective range of the parameter.

For finer settings use Parameter Change.

Transmit

When the "Control Change Tx Switch" is on and a parameter is edited via DME Designer, appropriate Control Change data will be transmitted as specified by the "MIDI Control Change Table" and "MIDI Tx Channel" settings.

Refer to "Supplementary Information 1" for cases in which multiple messages are assigned to a single parameter.

Status	Bnh (1011nnnnb)	Control Change
Data	cch (0cccccccb)	Control Change No. (1-31, 33-95, 102-119)
	vvh (0vvvvvvvb)	Control Value (0-127)

4.4 Parameter Change (F0h - F7h)

Receive

When the "Parameter Change Rx Switch" is On, Parameter Change messages are received on the MIDI channel specified by the "Device ID (Rx Ch)" parameter.

Transmit

When the “Parameter Change Tx Switch” is On and a parameter is edited via DME Designer, appropriate Parameter Change data will be transmitted as specified by the “MIDI Parameter Change Table” and “MIDI Tx Channel” settings.

Refer to “Supplementary Information 1” for cases in which multiple messages are assigned to a single parameter.

Refer to “Supplementary Information 2” for information on setting Parameter Data values.

Status	F0h (11110000b)	System Exclusive Message
ID No.	43h (01000011b)	Manufacturer’s ID No. (YAMAHA)
DEVICE ID.	1xh (0001xxxxb)	Rx/Tx Channel (0-15)
GROUP ID.	3Eh (00111110b)	Digital Mixer
MODEL ID.	10h (00010000b)	Device Code (DME)
Parameter Address	aah (0aaaaaab)	Parameter Address High
	aah (0aaaaaab)	Parameter Address Low
Parameter Data Value	ddh (0ddddddb)	data 0
	ddh (0ddddddb)	data 1
	ddh (0ddddddb)	data 2
	ddh (0ddddddb)	data 3
	ddh (0ddddddb)	data 4
EOX	F7h (11110111b)	End of Exclusive

Supplementary Information 1

Messages Transmitted When Multiple Messages are Assigned to the Same Parameter

The DME8i-C/DME8o-C/DME4io-C MIDI transmit messages are specified via the “MIDI Control Change Table” and “MIDI Parameter Change Table.”

(The “MIDI Control Change Table” and “MIDI Parameter Change Table” can be set up via DME Designer.)

Multiple messages can be assigned to a single parameter, but the DME8i-C/DME8o-C/DME4io-C will only transmit one of the assigned messages.

The transmitted messages are as follows:

- If a Control Change message and a Parameter Change message are assigned to the same parameter → the Control Change message will be transmitted.
- If multiple Control Change numbers are assigned to the same parameter → the smallest Control Change number message will be transmitted.
- If multiple Parameter Change numbers are assigned to the same parameter → the smallest Parameter Change number message will be transmitted.

Supplementary Information 2

Setting the Parameter Change Message Parameter Data Values

The Parameter change parameter values are expressed as 32-bit integers with or without parity.

- A parity bit (positive:0, negative:1) is added above the most significant value bit (bit 31).
- Fractional parameters will be converted according to the integer table.
- For integers with parity, negative numbers are expressed as the 2’s complement.

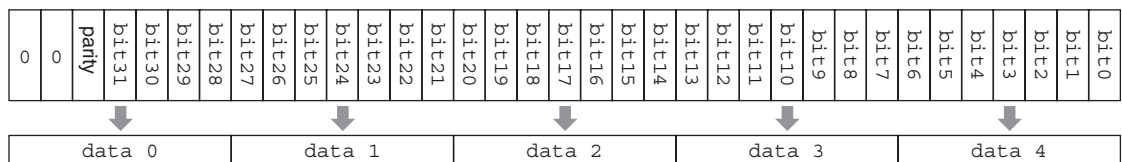

Example:

- Decimal value 1000 → Hexadecimal value 3E8h

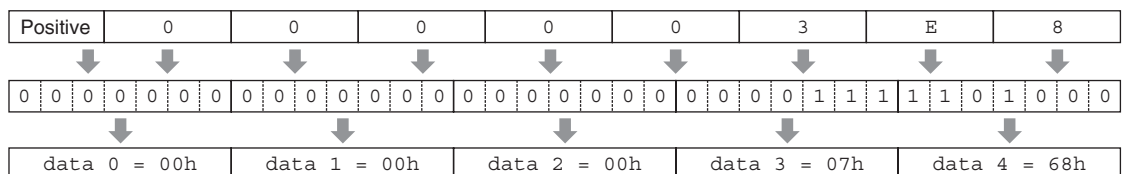

- Decimal value 1000 → Hexadecimal value FFFFC18h (2’s complement of 3E8h)

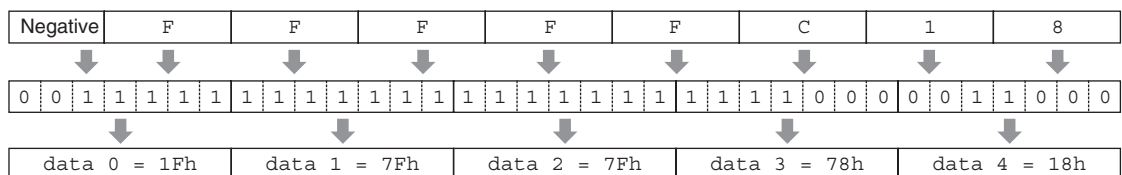

MIDI Implementation Chart

YAMAHA [Digital Mixing Engine Satellite]
 Model DME8i-C, DME8o-C, DME4io-C MIDI Implementation Chart

Date :16-FEB-2006
 Version : 1.0

Function...		Transmitted	Recognized	Remarks
Basic Channel	Default Changed	1 - 16 1 - 16	1 - 16 1 - 16	Memorized
Mode	Default Messages Altered	X X *****	X X X	
Note Number	: True voice	X *****	X X	
Velocity	Note ON Note OFF	X X	X X	
After Touch	Key's Ch's	X X	X X	
Pitch Bend		X	X	
Control Change	0,32 1-31,33-95,102-119	O *1 O *2	O *1 O *2	Bank Select Assignable
Prog Change	: True #	O 0 - 127 *1 *****	O 0 - 127 *1 0 - 127	
System Exclusive		O *3	O *3	Assignable
Common	: Song Pos. : Song Sel. : Tune	X X X	X X X	
System	: Clock Real Time : Commands	X X	X X	
Aux Messages	: All Sound Off : Reset All Cntrls : Local ON/OFF : All Notes OFF : Active Sense : Reset	X X X X X X	X X X X O X	
Notes:				
*1 transmit/receive if program change switch is on.				
*2 transmit/receive if control change switch is on.				
*3 transmit/receive if parameter change switch is on.				

Mode 1 : OMNI ON , POLY Mode 2 : OMNI ON , MONO O : Yes
 Mode 3 : OMNI OFF, POLY Mode 4 : OMNI OFF, MONO X : No

Display Messages

The [ERROR] and [PEAK] indicators on the front panel of the DME Satellite indicate error and warning messages.

Error Messages

Indicator	Error	Action
Lit 	Flashing A system error has occurred.	Execute the "Initialize DME" operation, then restart it. If the error indicators are still indicating the error, execute the "Delete All Data" initialization. If the problem persists, contact a Yamaha dealer.
Lit 	Flashing Data inside the internal flash memory has been erased.	The firmware update operation may have failed. Use DME Designer to execute the Recovery update operation. If the problem persists, contact a Yamaha dealer.
Lit 	Flashing The internal battery is completely discharged or not installed.	If you turn off the power to the unit, the current settings will be lost and reset to the default values. Stop operating the unit, and contact a Yamaha dealer regarding battery replacement.
Lit 	Flashing A scene recall attempt has failed.	Use DME Designer to recall the scene again. If the problem persists, contact a Yamaha dealer.
Lit 	Flashing Audio is not input or output and is muted due to insufficient DSP resources.	This error sometimes occurs if you try to operate a configuration at 96 kHz that has been created with a word clock of 48 kHz. To operate a configuration at any word clock setting, use DME Designer to create a configuration with the word clock set to 96 kHz.
Lit 	Flashing The network is not communicating properly.	Connect the network cables properly, and make sure that the network devices are operating correctly.
Lit 	Flashing Duplicate IP addresses.	Connect your computer to the DME Satellite via USB, then set a unique IP address.
Lit 	Flashing The DME Satellite contains data for a different device group or no data.	Send data appropriate for the actual device configuration from DME Designer.

Warning Messages

Indicator	Error	Action
Flashing rapidly 	The internal battery is almost discharged. Your data may be lost.	If you turn off the power to the unit, the current settings may be lost and reset to the default values. Stop operating the unit, and contact a Yamaha dealer regarding battery replacement.
Flashing slow 	The backup battery voltage is low.	This does not affect the operation of the unit. However, if you continue using the unit, the settings may be lost and reset to the default values. Contact a Yamaha dealer regarding battery replacement at your earliest convenience.

General Specifications

Sampling Frequency	Normal Rate:48kHz Double Rate:96kHz (±37ppm for conductor) (±50ppm for performer)	
Maximum Voltage Gain	Gain: -60dB, RL:600Ω, 64dB INPUT to OUTPUT	
Miscellaneous	Power Consumption	40W
	Dimensions (HxDxW)	44x361x480 mm
	Net Weight	4.4kg
	Temperature range	operating: 5 to 40°C storage: -20 to 60°C
	Include Accessories	AC Power cord, Mini Euro plug(16P)x1, Euro plug(3P)x8, Owner's Manual, Rubber feetx4

Electrical Characteristics

Output impedance of signal generator: 150 Ω

DME8i-C : Measured with DME8o-C

DME8o-C : Measured with DME8i-C

DME4io-C: Measured with DME4io-C

Frequency Response

fs=48kHz@20Hz–20kHz, reference to the nominal output level @1kHz

fs=96kHz@20Hz–40kHz, reference to the nominal output level @1kHz

<DME8i-C>

Input	Output	RL	CONDITIONS	MIN	TYP	MAX	UNITS
INPUT 1-8	OUTPUT 1-8	600Ω	input level: -60dBu, GAIN: -60dB	-1.5	0.0	+0.5	dB
			input level: +10dBu, GAIN: +10dB	-1.5	0.0	+0.5	dB

<DME8o-C>

Input	Output	RL	CONDITIONS	MIN	TYP	MAX	UNITS
INPUT 1-8	OUTPUT 1-8	600Ω	input level: +10dBu, GAIN: +10dB	-1.5	0.0	+0.5	dB

<DME4io-C>

Input	Output	RL	CONDITIONS	MIN	TYP	MAX	UNITS
INPUT 1-4	OUTPUT 1-4	600Ω	input level: -60dBu, GAIN: -60dB	-1.5	0.0	+0.5	dB
			input level: +10dBu, GAIN: +10dB	-1.5	0.0	+0.5	dB

Gain Error

@1kHz

<DME8i-C>

Input	Output	RL	CONDITIONS	MIN	TYP	MAX	UNITS
INPUT 1-8	OUTPUT 1-8	600Ω	input level: -60dBu, GAIN: -60dB	+2.0	+4.0	+6.0	dBu
			input level: +10dBu, GAIN: +10dB	+2.0	+4.0	+6.0	dBu

<DME8o-C>

Input	Output	RL	CONDITIONS	MIN	TYP	MAX	UNITS
INPUT 1-8	OUTPUT 1-8	600Ω	input level: +10dBu, GAIN: +10dB	+2.0	+4.0	+6.0	dBu

<DME4io-C>

Input	Output	RL	CONDITIONS	MIN	TYP	MAX	UNITS
INPUT 1-4	OUTPUT 1-4	600Ω	input level: -60dBu, GAIN: -60dB	+2.0	+4.0	+6.0	dBu
			input level: +10dBu, GAIN: +10dB	+2.0	+4.0	+6.0	dBu

Total Harmonic Distortion

fs=48kHz or 96kHz

<DME8i-C/DME4io-C>

Input	Output	RL	CONDITIONS	MIN	TYP	MAX	UNITS
<DME8i-C> INPUT 1-8 <DME4io-C> INPUT 1-4	OUTPUT 1-8	600Ω	+4dB@20Hz-20kHz (fs=48kHz), 20Hz-40kHz (fs=96kHz), GAIN: -60dB			0.1	%
			+4dB@20Hz-20kHz (fs=48kHz), 20Hz-40kHz (fs=96kHz), GAIN: +10dB			0.05	%
			+22dB@1kHz, GAIN: +10dB (fs=48kHz)			0.015	%
			+22dB@1kHz, GAIN: +10dB (fs=96kHz)			0.007	%

<DME8o-C>

Input	Output	RL	CONDITIONS	MIN	TYP	MAX	UNITS
INPUT 1-8	OUTPUT 1-8	600Ω	+4dB@20Hz-20kHz (fs=48kHz), 20Hz-40kHz (fs=96kHz), GAIN: +10dB			0.05	%
			+22dB@1kHz, GAIN: +10dB (fs=48kHz)			0.015	%
			+22dB@1kHz, GAIN: +10dB (fs=96kHz)			0.007	%

* Total Harmonic Distortion is measured with a 18dB/octave filter @80kHz.

Hum&Noise

fs=48kHz or 96kHz, EIN=Equivalent Input Noise

<DME8i-C>

Input	Output	RL	CONDITIONS	MIN	TYP	MAX	UNITS
INPUT 1-8	OUTPUT 1-8	600Ω	Rs=150Ω, GAIN: -60dB All input & output level controls: 0dB		-128 EIN	-127 EIN	dBu
					-64		dBu
			Rs=150Ω, GAIN: +10dB All input & output level controls: 0dB		-82	-79	dBu

<DME8o-C>

Input	Output	RL	CONDITIONS	MIN	TYP	MAX	UNITS
INPUT 1-8	OUTPUT 1-8	600Ω	Rs=150Ω, GAIN: +10dB All input & output level controls: 0dB		-82	-79	dBu

<DME4io-C>

Input	Output	RL	CONDITIONS	MIN	TYP	MAX	UNITS
INPUT 1-4	OUTPUT 1-4	600Ω	Rs=150Ω, GAIN: -60dB All input & output level controls: 0dB		-128 EIN	-127 EIN	dBu
					-64		dBu
			Rs=150Ω, GAIN: +10dB All input & output level controls: 0dB		-82	-79	dBu

* Hum & Noise are measured with a 6dB/octave filter @12.7kHz; equivalent to a 20kHz filter with infinite dB/octave attenuation.

Dynamic Range**fs=48kHz or 96kHz**

<DME8i-C/DME8o-C>

Input	Output	RL	CONDITIONS	MIN	TYP	MAX	UNITS
INPUT 1-8	OUTPUT 1-8	600Ω	GAIN: +10dB		106		dB

<DME4io-C>

Input	Output	RL	CONDITIONS	MIN	TYP	MAX	UNITS
INPUT 1-4	OUTPUT 1-4	600Ω	GAIN: +10dB		106		dB

* Dynamic range are measured with a 6dB/octave filter @12.7kHz; equivalent to a 20kHz filter with infinite dB/octave attenuation.

Crosstalk@1kHz**reference to the level of output N**

<DME8i-C/DME8o-C>

from	to	CONDITIONS	MIN	TYP	MAX	UNITS
INPUT N	OUTPUT (N-1) or (N+1)	N = 1-8, GAIN: +10dB			-80	dB

<DME4io-C>

from	to	CONDITIONS	MIN	TYP	MAX	UNITS
INPUT N	OUTPUT (N-1) or (N+1)	N = 1-4, GAIN: +10dB			-80	dB

* Crosstalk is measured with a 18dB/octave filter @80kHz

LED Level Meter

<DME8i-C>

METERING POINT	CONDITIONS	MIN	TYP	MAX	UNITS
INPUT 1-8	PEAK red LED: ON		-3		dBFS
	SIGNAL green LED: ON		-40		dBFS

<DME8o-C>

METERING POINT	CONDITIONS	MIN	TYP	MAX	UNITS
OUTPUT 1-8	PEAK red LED: ON		-3		dBFS
	SIGNAL green LED: ON		-40		dBFS

<DME4io-C>

METERING POINT	CONDITIONS	MIN	TYP	MAX	UNITS
INPUT 1-4 OUTPUT 1-4	PEAK red LED:ON		-3		dBFs
	SIGNAL green LED:ON		-40		dBFs

Signal Delay

PARAMETER	CONDITIONS	MIN	TYP	MAX	UNITS
CobraNet Latency: 5.33msec	ANALOG INPUT to ANALOG OUTPUT@96KHz		6.12		msec
CobraNet Latency: 2.67msec			3.45		msec
CobraNet Latency: 1.33msec			2.12		msec

Input/Output Characteristics

ANALOG INPUT CHARACTERISTICS

Input Terminals	GAIN	Actual Load Impedance	For Use With Nominal	Input Level		Connector
				Nominal	Max.before clip	
<DME8i-C> CH INPUT 1-8	-60dB	3k Ω	50-600 Ω Mics & 600 Ω Lines	-60dBu (0.775mV)	-40dBu (7.75mV)	EUROBLOCK (5.08mm pitch)
<DME4io-C> CH INPUT 1-4	+10dB			+10dBu (2.45V)	+30dBu (24.5V)	

*1.In these specifications, 0dBu is referenced to 0.775 Vrms.

*2.All AD converters are 24-bit linear, 128-times oversampling (Fs=48kHz)/64-times oversampling (Fs=96kHz).

*3.+48V DC (Phantom power) is supplied to CH INPUT EUROBLOCK connectors via each individual software controlled switch.

ANALOG OUTPUT CHARACTERISTICS

Output Terminals	Actual Source Impedance	For Use With Nominal	Output level		Connector
			Nominal	Max. before clip	
<DME8o-C> CH OUTPUT 1-8	75 Ω	600 Ω Lines	+4dBu (1.23 V)	+24dBu(12.28V)	EUROBLOCK (5.08mm pitch)
<DME4io-C> CH OUTPUT 1-4					

*1.In these specifications, 0dBu is referenced to 0.775 Vrms.

*2.All DA converters are 24-bit linear, 128-times oversampling (Fs=48kHz)/64-times oversampling (Fs=96kHz).

DIGITAL INPUT & OUTPUT CHARACTERISTICS

Terminal	Format	Data length	Level	Connector
CobraNet	CobraNet	16/20/24bit	100Base-TX	RJ-45x2 *1

*1.PRIMARY,SECONDARY

*2.Double Channel format and Single format are supported at 96kHz.

CONTROL I/O CHARACTERISTICS

Terminal		Format	Level	Connector
GPI	IN	–	0–5V	EUROBLOCK *1 (3.5mm pitch)
	OUT	–	TTL	
	+V	–	5V	
Ethernet		IEEE802.3	10Base-T/100Base-TX	RJ-45
USB		USB 1.1 Function	–	Type B
REMOTE		RS-232C/RS-422	RS-232C/RS-422	D-SUB 9P (Male)

*1 Inputs: 8 channels, Outputs: 4 channels
 Inputs: Not apply 2 wire Fader mode
 Outputs: I_{max}/pin = 16mA
 Outputs: V_H = 2.5V(min.), V_L = 0.6V(max.)

[NETWORK] Connector (100Base-TX Ethernet, RJ-45)

Pin	Connection
1	TxD+
2	TxD–
3	RxD+
4	Unused
5	Unused
6	RxD–
7	Unused
8	Unused

Straight and Crossover Cable Wiring**Straight Cables**

Pins
1 – 1
2 – 2
3 – 3
4 – 4
5 – 5
6 – 6
7 – 7
8 – 8

Crossover Cables

Pins
1 – 3
2 – 6
3 – 1
4 – 4
5 – 5
6 – 2
7 – 7
8 – 8

Dimensions

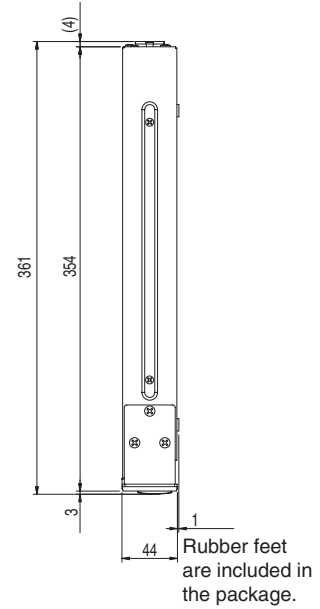
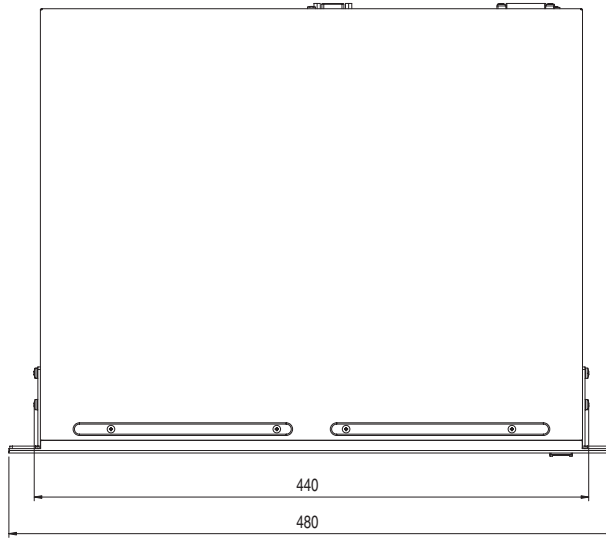
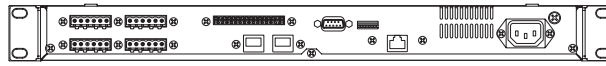

Unit: mm

* Specifications and descriptions in this owner's manual are for information purpose only. Yamaha Corp. reserves the right to charge or modify products or specifications at any time without prior notice. Since specifications, equipment or options may not be the same in every locale, please check with your Yamaha dealer.

European models

Purchaser/User Information specified in EN55103-1 and EN55103-2.

Inrush Current: 35A

Conforms to Environments: E1,E2,E3 and E4.

Index

- A**
- About DME Designer 14
 - [AC IN] Connector 20
 - Analog Audio Connection 29
 - area 10
- B**
- Bundle 15
- C**
- CobraNet 15
 - CobraNet Connection 32
 - CobraNet [PRIMARY]/[SECONDARY] Connectors 21
 - Components 10
 - conductor priority 17
 - Conductors 17
 - Configuration 10
 - CP4SW, CP4SF, and CP1SF 36
- D**
- Delete All Data 35
 - device group 10
 - Digital Audio Connection 28
 - Dimensions 48
 - Dip Switch 20
 - Display Messages 42
 - DME4io-C 9
 - DME8i-C 9
 - DME8o-C 9
- E**
- Electrical Characteristics 43
 - [ERROR] Indicator 19
 - Error Messages 42
 - Ethernet Connection 24
 - Euroblock plug connection 29
- F**
- Firmware Version 7
- G**
- General Specifications 43
 - GPI Connection 34
 - [GPI] Connector 21
 - Ground Screw 20
 - group master 10
- I**
- ICP1 36
 - [IN USE/CONDUCTOR] Indicator 19
 - Initialize DME 35
 - Initializing 35
 - [INPUT] & [OUTPUT] Connectors 29
 - [INPUT] Connectors 21
 - Input/Output Characteristics 46
- L**
- [LINK/ACTIVITY] Indicator 19
- M**
- MAC Address 21
 - Master and slave setting 23
 - [MASTER] Indicator 18
 - MIDI Data Format 38
 - MIDI Implementation Chart 41
 - multicast bundles 16
 - multi-unicast bundles 16
- N**
- [NETWORK] Connector 20, 47
 - [NETWORK] Indicator 18
 - Network Settings 23
- O**
- octet 23
 - Options 36
 - [OUTPUT] Connectors 21
- P**
- parameters 10
 - [PEAK] Indicators 19
 - performers 17
 - [POWER] Switch 19
 - Precautions for Using a Rack-mounted DME Satellite 8
 - preset parameters 10
 - primary 19
- R**
- Remote Connection 30
 - [REMOTE] Connector 20
 - RS-232C 20
 - RS-422 20

S

Scene 11
secondary (backup) 19
Setting the IP address 23
[SIGNAL] Indicators 19
Signal Types 12
Straight and Crossover Cable Wiring 47
System Examples 13

T

Troubleshooting 37

U

unicast bundles 16
USB Connection 22
[USB] Connector 18
User Defined buttons (User Defined parameters) 10

W

Warning Messages 42

Z

zones 10

For details of products, please contact your nearest Yamaha representative or the authorized distributor listed below.

Pour plus de détails sur les produits, veuillez-vous adresser à Yamaha ou au distributeur le plus proche de vous figurant dans la liste suivante.

Die Einzelheiten zu Produkten sind bei Ihrer unten aufgeführten Niederlassung und bei Yamaha Vertragshändlern in den jeweiligen Bestimmungsländern erhältlich.

Para detalles sobre productos, contacte su tienda Yamaha más cercana o el distribuidor autorizado que se lista debajo.

NORTH AMERICA

CANADA

Yamaha Canada Music Ltd.
135 Milner Avenue, Scarborough, Ontario,
M1S 3R1, Canada
Tel: 416-298-1311

U.S.A.

Yamaha Corporation of America
6600 Orangethorpe Ave., Buena Park, Calif. 90620,
U.S.A.
Tel: 714-522-9011

CENTRAL & SOUTH AMERICA

MEXICO

Yamaha de México S.A. de C.V.
Calz. Javier Rojo Gómez #1149,
Col. Guadalupe del Moral
C.P. 09300, México, D.F., México
Tel: 55-5804-0600

BRAZIL

Yamaha Musical do Brasil Ltda.
Rua Joaquim Floriano, 913 - 4º andar, Itaim Bibi,
CEP 04534-013 Sao Paulo, SP. BRAZIL
Tel: 011-3704-1377

ARGENTINA

Yamaha Music Latin America, S.A.
Sucursal de Argentina
Olga Cossetini 1553, Piso 4 Norte
Madero Este-C1107CEK
Buenos Aires, Argentina
Tel: 011-4119-7000

PANAMA AND OTHER LATIN AMERICAN COUNTRIES/ CARIBBEAN COUNTRIES

Yamaha Music Latin America, S.A.
Torre Banco General, Piso 7, Urbanización Marbella,
Calle 47 y Aquilino de la Guardia,
Ciudad de Panamá, Panamá
Tel: +507-269-5311

EUROPE

THE UNITED KINGDOM

Yamaha Music U.K. Ltd.
Sherbourne Drive, Tilbrook, Milton Keynes,
MK7 8BL, England
Tel: 01908-366700

GERMANY

Yamaha Music Central Europe GmbH
Siemensstraße 22-34, 25462 Rellingen, Germany
Tel: 04101-3030

SWITZERLAND/LIECHTENSTEIN

Yamaha Music Central Europe GmbH,
Branch Switzerland
Seefeldstrasse 94, 8008 Zürich, Switzerland
Tel: 01-383 3990

AUSTRIA

Yamaha Music Central Europe GmbH,
Branch Austria
Schleiergasse 20, A-1100 Wien, Austria
Tel: 01-60203900

CZECH REPUBLIC/SLOVAKIA/ HUNGARY/SLOVENIA

Yamaha Music Central Europe GmbH,
Branch Austria, CEE Department
Schleiergasse 20, A-1100 Wien, Austria
Tel: 01-602039025

POLAND

Yamaha Music Central Europe GmbH
Sp.z. o.o. Oddział w Polsce
ul. 17 Stycznia 56, PL-02-146 Warszawa, Poland
Tel: 022-868-07-57

THE NETHERLANDS/ BELGIUM/LUXEMBOURG

Yamaha Music Central Europe GmbH,
Branch Benelux
Clarissenhof 5-b, 4133 AB Vianen, The Netherlands
Tel: 0347-358 040

FRANCE

Yamaha Musique France
BP 70-77312 Marne-la-Vallée Cedex 2, France
Tel: 01-64-61-4000

ITALY

Yamaha Musica Italia S.P.A.
Combo Division
Viale Italia 88, 20020 Lainate (Milano), Italy
Tel: 02-935-771

SPAIN/PORTUGAL

Yamaha Música Ibérica, S.A.
Ctra. de la Coruna km. 17, 200, 28230
Las Rozas (Madrid), Spain
Tel: 91-639-8888

SWEDEN

Yamaha Scandinavia AB
J. A. Wettergrens Gata 1, Box 30053
S-400 43 Göteborg, Sweden
Tel: 031 89 34 00

DENMARK

YS Copenhagen Liaison Office
Generatorvej 6A, DK-2730 Herlev, Denmark
Tel: 44 92 49 00

NORWAY

Norsk filial av Yamaha Scandinavia AB
Grini Næringspark 1, N-1345 Østerås, Norway
Tel: 67 16 77 70

RUSSIA

Yamaha Music (Russia)
Office 4015, entrance 2, 21/5 Kuznetskii
Most street, Moscow, 107996, Russia
Tel: 495 626 0660

OTHER EUROPEAN COUNTRIES

Yamaha Music Central Europe GmbH
Siemensstraße 22-34, 25462 Rellingen, Germany
Tel: +49-4101-3030

AFRICA

Yamaha Corporation,
Asia-Pacific Music Marketing Group
Nakazawa-cho 10-1, Naka-ku, Hamamatsu,
Japan 430-8650
Tel: +81-53-460-2313

MIDDLE EAST

TURKEY/CYPRUS

Yamaha Music Central Europe GmbH
Siemensstraße 22-34, 25462 Rellingen, Germany
Tel: 04101-3030

OTHER COUNTRIES

Yamaha Music Gulf FZE
LOB 16-513, P.O.Box 17328, Jubel Ali,
Dubai, United Arab Emirates
Tel: +971-4-881-5868

ASIA

THE PEOPLE'S REPUBLIC OF CHINA

Yamaha Music & Electronics (China) Co.,Ltd.
25/F., United Plaza, 1468 Nanjing Road (West),
Jingan, Shanghai, China
Tel: 021-6247-2211

INDONESIA

PT. Yamaha Music Indonesia (Distributor)
PT. Nusantik
Gedung Yamaha Music Center, Jalan Jend. Gatot
Subroto Kav. 4, Jakarta 12930, Indonesia
Tel: 21-520-2577

KOREA

Yamaha Music Korea Ltd.
8F, 9F, Dongsung Bldg. 158-9 Samsung-Dong,
Kangnam-Gu, Seoul, Korea
Tel: 080-004-0022

MALAYSIA

Yamaha Music Malaysia, Sdn., Bhd.
Lot 8, Jalan Perbandaran, 47301 Kelana Jaya,
Petaling Jaya, Selangor, Malaysia
Tel: 3-78030900

SINGAPORE

Yamaha Music Asia Pte., Ltd.
#03-11 A-Z Building
140 Paya Lebar Road, Singapore 409015
Tel: 747-4374

TAIWAN

Yamaha KHS Music Co., Ltd.
3F, #6, Sec.2, Nan Jing E. Rd. Taipei.
Taiwan 104, R.O.C.
Tel: 02-2511-8688

THAILAND

Siam Music Yamaha Co., Ltd.
891/1 Siam Motors Building, 15-16 floor
Rama 1 road, Wangmai, Pathumwan
Bangkok 10330, Thailand
Tel: 02-215-2626

OTHER ASIAN COUNTRIES

Yamaha Corporation,
Asia-Pacific Music Marketing Group
Nakazawa-cho 10-1, Naka-ku, Hamamatsu,
Japan 430-8650
Tel: +81-53-460-2317

OCEANIA

AUSTRALIA

Yamaha Music Australia Pty. Ltd.
Level 1, 99 Queensbridge Street, Southbank,
Victoria 3006, Australia
Tel: 3-9693-5111

COUNTRIES AND TRUST TERRITORIES IN PACIFIC OCEAN

Yamaha Corporation,
Asia-Pacific Music Marketing Group
Nakazawa-cho 10-1, Naka-ku, Hamamatsu,
Japan 430-8650
Tel: +81-53-460-2313

HEAD OFFICE Yamaha Corporation, Pro Audio & Digital Musical Instrument Division
Nakazawa-cho 10-1, Naka-ku, Hamamatsu, Japan 430-8650
Tel: +81-53-460-2441



Yamaha Pro Audio global web site:
<http://www.yamahaproaudio.com/>
Yamaha Manual Library
<http://www.yamaha.co.jp/manual/>

U.R.G., Pro Audio & Digital Musical Instrument Division, Yamaha Corporation
© 2006 Yamaha Corporation
WK83890 804IPDHx.x-02D0
Printed in Japan