

LED Monitor

User Manual

The color and the appearance may differ depending on the product, and the specifications are subject to change without prior notice to improve the performance.



Table Of Contents

MAJOR SAFETY PRECAUTIONS

Before You Start	1-1
Care and Maintenance	1-2
Cleaning the Monitor	1-3
Safety Precautions	1-4

INSTALLING THE PRODUCT

Package Contents	2-1
Installing the Stand	2-2
Adjusting the Product Tilt and Height	2-3
Rotating the Monitor Screen	2-4
Installing a Wall-mount Kit or Desktop Stand	2-5
Connecting to your Network	2-6
Connecting the Power	2-7
Connecting to another Monitor	2-8
Connecting a SERIAL Cable	2-9
Connecting with a PC	2-10
Connecting a Stereo Cable	2-11
Connecting Headphones	2-12
Connecting MIC	2-13
Kensington Lock	2-14

USING THE PRODUCT

What is a PC over IP?	3-1
Connect to the host PC using a LAN cable	3-2
Plug & Play	3-3
Standard Signal Mode Table	3-4
Installing the Device Driver	3-5
Installing a USB-to-Serial Driver	3-6
Product Operating Buttons	3-7
Using the Screen Adjustment Menu (OSD: On Screen Display)	3-8

INSTALLING THE SOFTWARE

PCoIP	4-1
Natural Color	4-2
MultiScreen	4-3

TROUBLESHOOTING

Monitor Self-Diagnosis	5-1
Before Requesting Service	5-2
FAQ	5-3

MORE INFORMATION



Specifications	6-1
Power Saving Function	6-2

Contact SAMSUNG WORLDWIDE	6-3
Correct Disposal of This Product (Waste Electrical & Electronic Equipment)	6-4

1 Major Safety Precautions

1-1 Before You Start

Icons used in this manual

ICON	NAME	MEANING
	Caution	Indicates cases where the function may not work or the setting may be canceled.
	Note	Indicates a hint or tip to operate a function.

Using this Manual

- Make yourself fully aware of the safety precautions before using this product.
- If a problem occurs, refer to the 'Troubleshooting' section.

Copyright Notice

The contents of this manual are subject to change without prior notice for performance improvement.

Copyright © 2011 Samsung Electronics Co., Ltd. All Rights Reserved.

The copyright of this manual is reserved by Samsung Electronics, Co., Ltd.

The contents of this manual may not be partially or in whole reproduced, distributed or used in any form without the written permission of Samsung Electronics, Co., Ltd.

The SAMSUNG logo and SyncMaster are the registered trademarks of Samsung Electronics, Co., Ltd.

Microsoft, Windows and Windows NT are the registered trademarks of Microsoft Corporation.

VESA, DPM and DDC are the registered trademarks of the Video Electronics Standard Association.

All other trademarks mentioned herein belong to their respective companies.

An administration fee may be charged if either

(a) an engineer is called out at your request and there is no defect in the product.

(i.e. where you have failed to read this user manual).

(b) you bring the unit to a repair centre and there is no defect in the product.

(i.e. where you have failed to read this user manual).

The amount of such administration charge will be advised to you before any work or home visit is carried out.

1-2 Care and Maintenance

External Surface and Screen Maintenance

Clean the product with a soft, damp cloth.

- Do not clean the product with an inflammable substance such as benzene or thinner or with a wet cloth. This may result in a problem with the product.
- Do not scratch the screen with your fingernails or a sharp object.
This may result in scratches or damage to the product.
- Do not clean the product directly by spraying water onto the product.
If water enters the product, it may result in fire, electric shock or a problem with the product.
- A white stain may be generated on the surface of the high-glossy model due to the inherent characteristics of the material, if a supersonic humidifier is used.

 The appearance and the color may differ depending on the model.

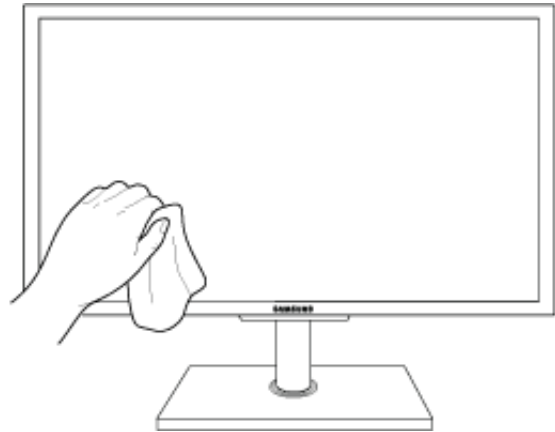

Securing the Installation Space

- Keep the required distances between the product and other objects (e.g. walls) to ensure proper ventilation. Failing to do so may result in fire or a problem with the product due to an increase in the internal temperature. Install the product so the required distances shown in the figure are kept.

 The appearance may differ depending on the product.

When installing the product with a stand

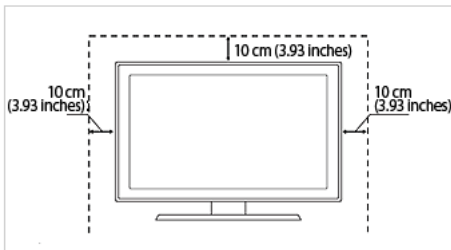

When installing the product with a wall-mount

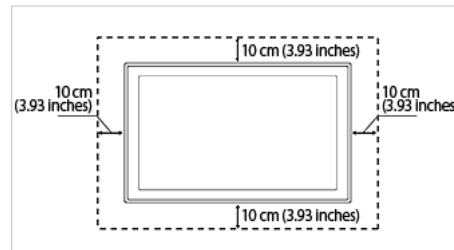

About persistent images

- Displaying a still image for a long time may create a persistent image or stain on the screen. If you do not use the product for a long time, set the power-saving mode or screen saver.
- Due to technological constraints of the Panel manufacturer, the images generated by this product may appear either brighter or darker than normal by appr. 1ppm (parts per million) pixel.

The number of sub-pixels of an panel by size: The number of Sub-Pixels = Max. Horizontal Resolution x Max. Vertical Resolution x 3

Example) If the maximum resolution is 1680 x 1050, the number of sub-pixels is 1680 x 1050 x 3 = 5.292.000.

1-3 Cleaning the Monitor

Cleaning the Monitor

- The panel and exterior of the cutting-edge monitor scratch easily and require careful attention. Clean the monitor according to the following steps.

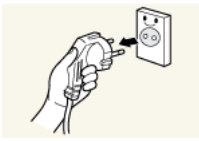

1. Power off the monitor and PC.
2. Disconnect the power cable from the monitor.

 To avoid electric shock, be sure you disconnect the cable by gripping the plug and do not touch the cable with wet hands.



3. Wipe the monitor using a soft, slightly damp cloth that has been squeezed .



- Do not use a cleaning agent that contains alcohol or solvents, or that is surface active. Otherwise, the exterior may discolor or crack or the panel coating may come off.



- Do not spray water or cleaning agent directly onto the monitor. Otherwise, the liquid may sink into the monitor and cause a fire, electric shock, or failure.

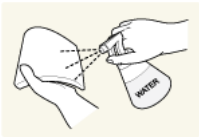

4. Clean the exterior of the monitor using a soft cloth dampened with a small amount of water.

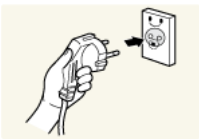

5. Connect the power cable to the monitor after you have finished cleaning.
6. Power on the monitor and PC.

Precautions for Storage

- Using an ultrasonic humidifier may cause white stains on a highly glossy product.

 Be sure you contact the nearest service center (paid service) for cleaning the inside of the monitor.

1-4 Safety Precautions

Icons used for safety precautions

ICON	NAME	MEANING
	Warning	Failing to follow the precautions marked with this sign, may result in a serious injury or even a fatality.
	Caution	Failing to follow the precautions marked with this sign, may result in a personal injury or property damage.

Meaning of Signs



Do not perform.



Must be followed.

Power Related

The following images are for your reference and may differ depending on models and countries.

Warning

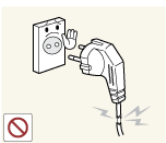

Avoid using a damaged power cord or plug or a loose power outlet.

- Otherwise, it may result in electric shock or fire.



Avoid connecting multiple electric appliances to a single wall outlet.

- Otherwise, it may result in fire due to overheating of the wall outlet.



Avoid plugging in or unplugging the power supply with wet hands.

- Otherwise, it may result in electric shock.

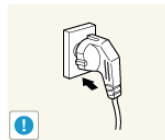

Plug the power plug in firmly.

- Otherwise, it may result in fire.

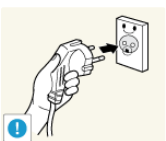

Make sure to connect the power cord to a grounded wall outlet (for insulation class 1 equipment only).

- Otherwise, it may result in electric shock or injury.



Avoid bending or twisting the power cord excessively and avoid placing heavy objects on the cord.

- Otherwise, it may result in electric shock or fire due to a damaged power cord.

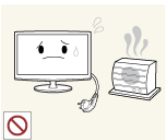

Keep the power cord and the product away from a heater.

- Otherwise, it may result in electric shock or fire.



If the pins of the power plug or the wall outlet are covered in dust, clean it using a dry cloth.

- Otherwise, it may result in fire.

Caution

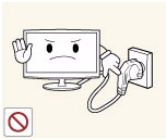

Avoid unplugging the power plug while the product is operating.

- Otherwise, it may damage the product due to electric shock.

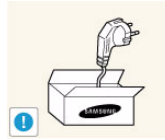

Make sure to use only the power cord supplied by Samsung. In addition, do not use the power cord of another electric appliance.

- Otherwise, it may result in electric shock or fire.

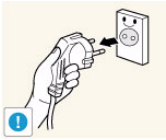

When unplugging the power plug from the wall outlet, make sure to hold it by the plug and not by the cord.

- Otherwise, it may result in electric shock or fire.



Connect the power plug to a wall outlet that can be easily reached.

- When a problem occurs with the product, you must unplug the power plug to cut the power off completely. You cannot cut the power off completely using only the power button on the product.

Installation Related

Warning



AVOID PLACING BURNING CANDLES, MOSQUITO-REPELLENT OR CIGARETTES ON THE PRODUCT AND INSTALLING THE PRODUCT NEAR A HEATER.

- Otherwise, it may result in fire.

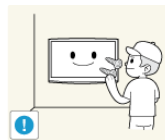

Ask an installation engineer or relevant company to install the product onto a wall.

- Otherwise, it may result in injury.
- Make sure to use the specified wall mount.



Avoid installing the product in a badly-ventilated location such as inside a bookshelf or closet.

- Otherwise, it may result in fire due to internal over-heating.



Avoid installing the product in a location that is unstable or exposed to excessive vibrations such as on an unstable or slanted shelf.

- The product may fall and this may result in damage to the product or injury.
- If you use the product in a location exposed to excessive vibrations, it may result in a problem with the product or fire.



Keep the plastic bags used to pack the product away from children.

- If children place the plastic bags over their heads, they may suffocate.



Avoid installing the product in a location exposed to direct sunlight or heat source such as a fire or heater.

- This may shorten the product life cycle or cause fire.



Avoid installing the product at a height where children may reach it.

- If a child touches the product, the product may fall and this may result in injury.
- Since the front part is heavier, install the product on a flat and stable surface.



Avoid installing the product in a location exposed to dust, moisture (sauna), oil, smoke or water (rain drops) and installing it within a vehicle.

- This may result in electric shock or fire.



Edible oil, such as soybean oil, can damage or deform the product. Do not install the product in a kitchen or near a kitchen counter.

Caution



Do not let the product drop while moving it.

- This may result in a problem with the product or injury.

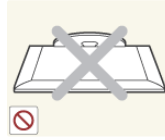

Do not place the product face down on the floor.

- This may damage the panel of the product.



When installing the product on a console or shelf, make sure that the front of the product does not protrude out of the console or shelf.

- Otherwise, this may cause the product to fall off and result in a malfunction or injury.
- Make sure to use a cabinet or shelf suitable to the size of the product.



When putting the product down, handle it gently.

- Otherwise, it may result in a problem with the product or injury.



If the product is installed in a location where the operating conditions vary considerably, a serious quality problem may occur due to the surrounding environment. In this case, install the product only after consulting one of our service engineers about the matter.

- Places exposed to microscopic dust, chemicals, too high or low temperature, high humidity, such as airports or stations where the product is continuously used for a long time and so on.

Usage Related

Warning



Since a high voltage runs through the product, never disassemble, repair or modify the product yourself.

- Otherwise, it may result in fire or electric shock.
- If the product needs to be fixed, contact a service center.



Before moving the product, turn off the power switch and disconnect the power cable and all other connected cables.

- Otherwise, the power cord may be damaged and a fire or electric shock may result.



If the product generates a strange noise, a burning smell, or smoke, unplug the power plug immediately and contact a service center.

- Otherwise, it may result in electric shock or fire.



Avoid letting children to hang or climb onto the product.

- Otherwise, it may result in the product falling and this may result in injury or death.



If you drop the product or the case is damaged, turn the power off and unplug the power cord. Contact a service center.

- Otherwise, it may result in fire or electric shock.



Avoid placing objects such as toys and cookies on top of the product.

- If a child hangs over the product to grab an object, the object or the product may fall and this may result in injury or even death.

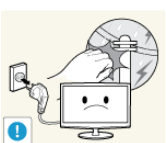

During a lightning or thunderstorm, power off the product and remove the power cable.

- Otherwise, it may result in electric shock or fire.



Avoid dropping an object over the product or cause impact to the product.

- Otherwise, it may result in electric shock or fire.



Avoid moving the product by pulling the power cord or antenna cable.

- Otherwise, it may result in electric shock, fire or a problem with the product due to damage to the cable.

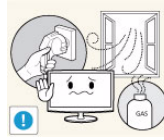

When a gas leak occurs, do not touch the product or the power plug and ventilate immediately.

- A spark may result in an explosion or fire.

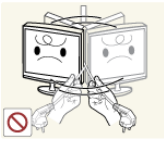

Avoid lifting up or move the product by holding only the power cord or signal cable.

- Otherwise, it may result in electric shock, fire or a problem with the product due to damage to the cable.

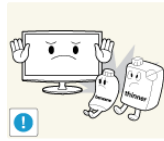

Avoid using or placing inflammable spray or objects near the product.

- This may result in an explosion or fire.



Take care not to block the vent by a table cloth or curtain.

- Otherwise, it may result in fire due to internal overheating.



Avoid inserting metal objects such as a chopsticks, coins or hairpins, or inflammable objects into the product (the vents, ports, etc).

- If water or an alien substance enters the product, turn the power off, unplug the power cord and contact a service center.
- Otherwise, it may result in a problem with the product, electric shock or fire.



Avoid placing a liquid container such as a vase, flowerpot, beverage, cosmetics or drugs, or a metal object over the product.

- If water or an alien substance enters the product, turn the power off, unplug the power cord and contact a service center.
- Otherwise, it may result in a problem with the product, electric shock or fire.

Caution



Displaying a still image for a long time may create a persistent image or stain on the screen.

- If you do not use the product for a long time, use the power-saving mode or set the screensaver to the moving picture mode.

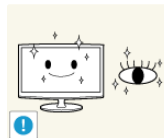

It is important to give your eyes some rest (5 minutes every hour) when viewing the product screen for long periods of time.

- This will alleviate any eye strain.



Set the appropriate resolution and frequency for the product.

- Otherwise, it may result in eye strain.

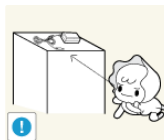

Keep small accessories away from the children.

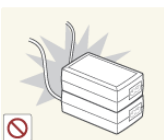

Do not put DC power adapters together.

- Otherwise, a fire may result.



Avoid placing a heavy object over the product.

- Otherwise, it may result in a problem with the product or injury.



Remove the plastic bag from the DC power adapter before you use it.

- Otherwise, a fire may result.



When not using the product for a long time such as leaving your home, unplug the power cord from the wall outlet.

- Otherwise, it may cause dust accumulation and result in fire caused by overheating or short circuit or result in an electric shock.



Do not let water enter the DC power device or get the device wet.

- An electric shock or fire may result.
- Avoid using the product outdoors where it can be exposed to rain or snow.
- Be careful not to get the DC power adapter wet when you wash the floor.



Avoid turning the product upside down or move the product holding only the stand.

- This may cause the product to fall resulting in damage to the product or injury.

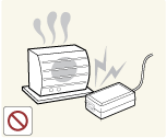

Do not put the DC power adapter near to any heating apparatus.

- Otherwise, a fire may result.



Avoid using a humidifier or cooker near the product.

- Otherwise, it may result in electric shock or fire.

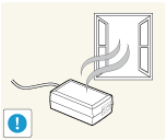

Keep the DC power adapter in a well-ventilated area.



Since the display panel is hot after using it for a long time, do not touch the product.

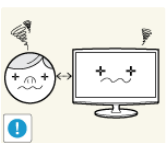

Watching the product from too close a distance continuously may damage your eyesight.

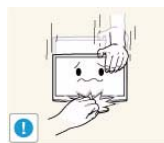

Take care when adjusting the angle of the product or the height of the stand.

- If your hand or finger is caught, you may be injured.
- If the product is tilted excessively, the product may fall and this may result in injury.

Maintaining the Correct Posture when Using this Product

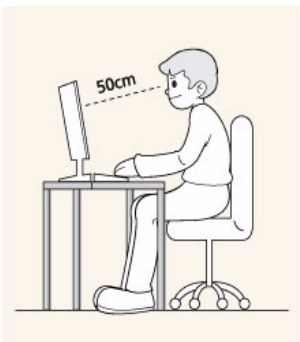

Use the product in the correct posture as follows:

- Straighten your back.
- Keep a distance of 45~50 cm(18~ 20inches) from your eyes to the screen. Look down at the screen and face the screen forwards.
- Adjust the angle of the product so that light is not reflected onto the screen.
- Keep your elbow at a right angle and keep your arm level with the back of your hand.
- Keep your elbow at a right angle.
- Place your heels flat on the ground while keeping your knees at an angle of 90 degrees or higher and maintain the position of your arm so that your arm is below your heart.















2 Installing the Product

2-1 Package Contents

- Unpack the product and check if all of the following contents have been included.
- Store the packaging box in case you need to move the product at a later stage.
- If any items are missing, contact your dealer.
- Contact a local dealer to purchase optional items.



Monitor

CONTENTS			
			
Quick Setup Guide	Warranty Card (Not available in all locations)	User Manual	DC power adapter
			
Power cable	Stand base		
OPTIONAL PARTS			
			
LAN Cable	DVI Cable	Stereo Cable	Mouse (USB)
			
Keyboard	Headphone	D-Sub Cable	USB Cable
			
RS-232C Cable			

- The color and the appearance may differ depending on the product, and the specifications are subject to change without prior notice to improve the performance.

2-2 Installing the Stand

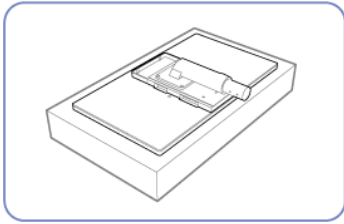

Place a soft cloth over the table to protect the product and place the product onto the cloth so that the front of the product is facing downwards.

Turn the stand in the direction indicated by the arrow.

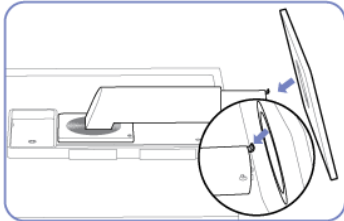

Insert the stand base into the stand in the direction of the arrow.

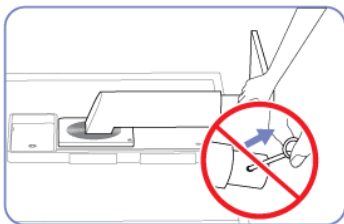

Do not remove the fixing pin until you are finished attaching the stand.

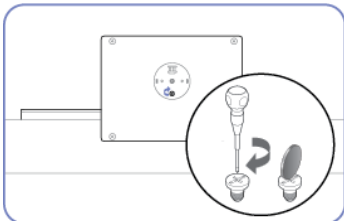

Tightly fasten the screw to the bottom of the base.



After installing the stand, place the product upright.

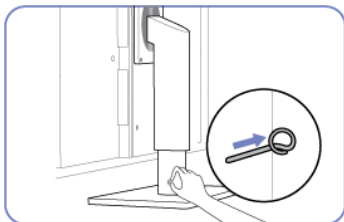

You can remove the fixing pin and adjust the stand now.

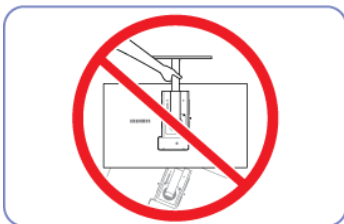

- Caution

Do not hold the product upside down only by the stand.

- Disassembly is in the reverse order of the assembly.
- The color and the appearance may differ depending on the product, and the specifications are subject to change without prior notice to improve the performance.

2-3 Adjusting the Product Tilt and Height

- The color and shape of parts may differ from what is shown. Specifications are subject to change without notice to improve quality.

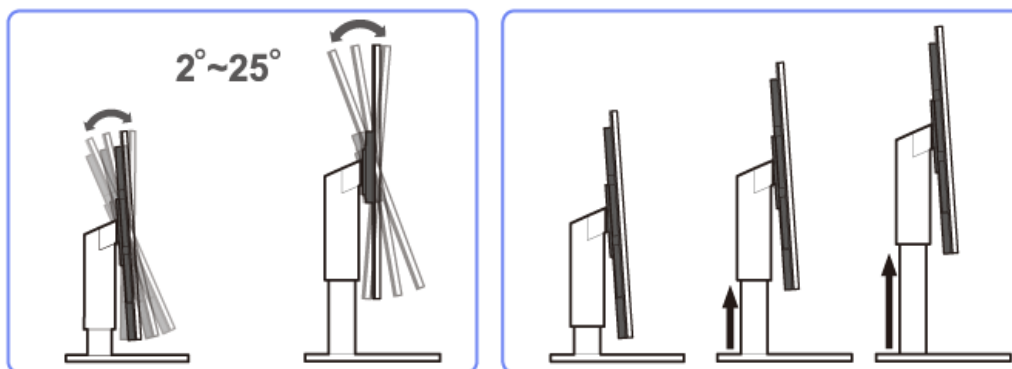

- To adjust the height, remove the fixing pin.
- The monitor tilt and height can be adjusted.
- Hold the top center of the product and adjust the height carefully.

2-4 Rotating the Monitor Screen

You can rotate your monitor as shown below.

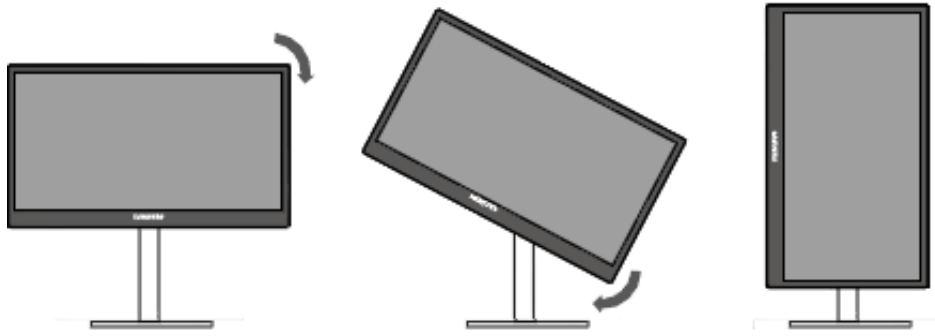

- Be sure to fully extend the stand before rotating the monitor.
- If you rotate the monitor without fully extending the stand, the corner of the monitor may hit the floor and get damaged.
- Do not rotate the monitor counterclockwise. The monitor may get damaged.

2-5 Installing a Wall-mount Kit or Desktop Stand

Before Installation

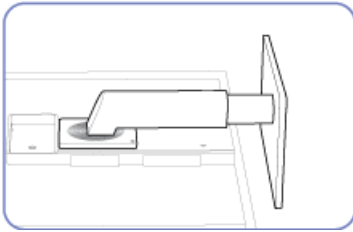

Place a protective cloth or cushion on a flat surface. Next, place the product with the face down on top of the cloth or cushion.

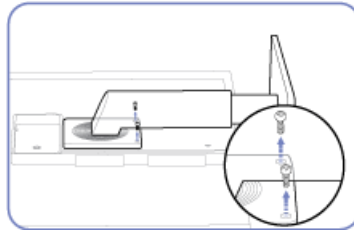

Unfasten the screw from the back of the product.

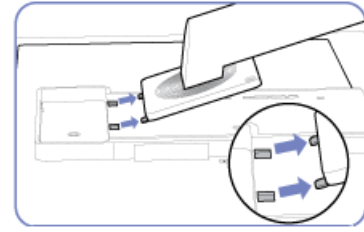

Lift and detach the stand.

Installing a Wall-mount Kit or Desktop Stand

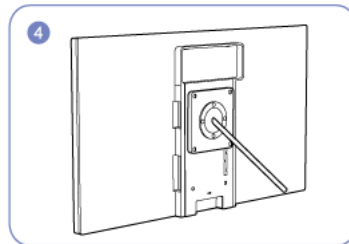
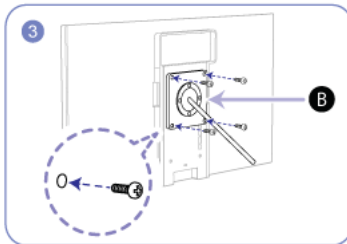
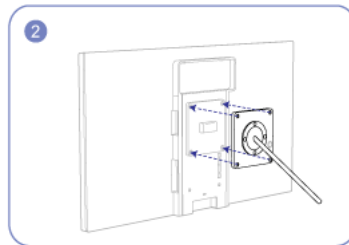
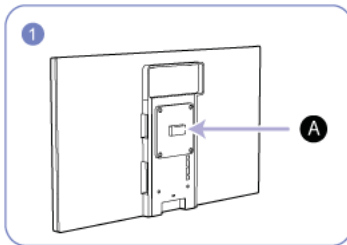

A Attach the wall-mount kit or desktop stand here

B Bracket (sold separately)

Align the grooves and tightly fasten the screws on the bracket on the product with the corresponding parts on the wall-mount kit or desktop stand you want to attach.

- !** Using a screw longer than the standard length can damage the internal components of the product.
- The length of screws required for a wall mount that does not comply with the VESA standards may vary depending on the specifications.
- Do not use screws that do not comply with the VESA standards. Do not attach the wall-mount kit or desktop stand using excessive force. The product may get damaged or fall and cause personal injury. Samsung shall not be held liable for any damage or injury caused by using improper screws or attaching the wall-mount kit or desktop stand using excessive force.
- Samsung shall not be held liable for any product damage or personal injury caused by using a wallmount kit other than the one specified or from an attempt to install the wall-mount kit on your own.
- To mount the product on a wall, ensure you purchase a wall-mount kit that can be installed 10cm or farther away from the wall.
- Be sure to use a wall-mount kit that complies with the standards.

2-6 Connecting to your Network

 The connecting part may differ depending on the product model.

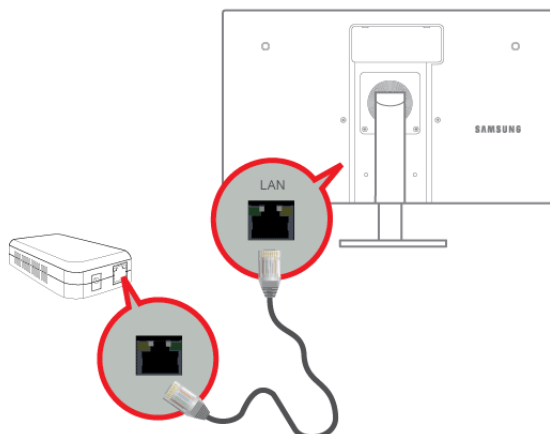

- Connect between the [LAN] port on the product and your network using a LAN cable.
-  The two [LAN] ports are designed to work as an Internet HUB. One port can be used for input and the other port for output to connect the product to an external Internet device.

2-7 Connecting the Power

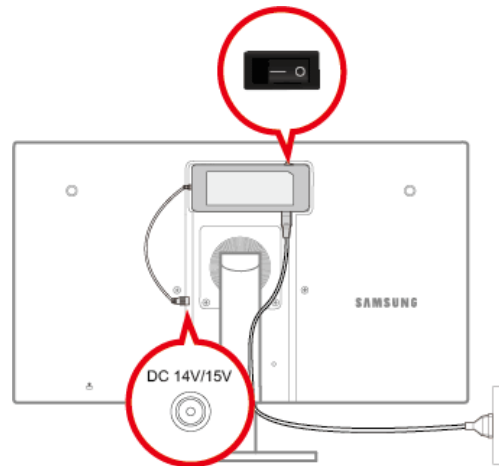

- To use the monitor, connect the power cable to a power outlet and the [POWER] port on the monitor. (The input voltage is switched automatically.)

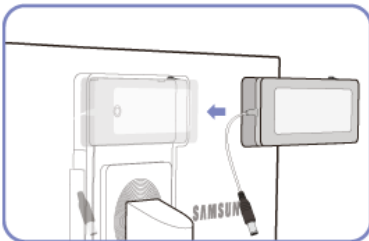

Put the DC power adapter in the groove, with the switch facing upward.
- Push the adapter until you hear a “click.”

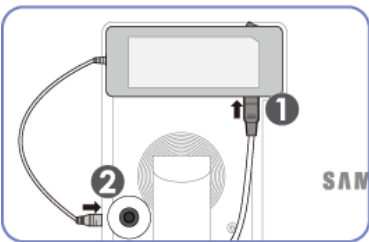

Connect the power cable to the DC power adapter. Next, connect the DC power adapter to the product.

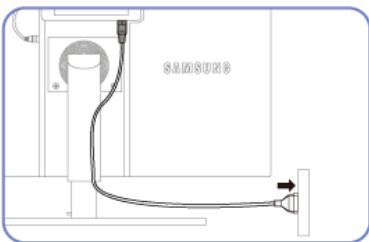

Plug in the power cable to the power socket.

Removing the DC power adapter

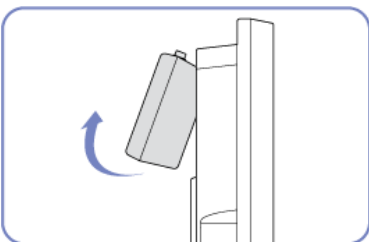

To remove the DC power adapter, lift it outwards from the bottom as shown in the image.

2-8 Connecting to another Monitor

 The connecting part may differ depending on the product model.

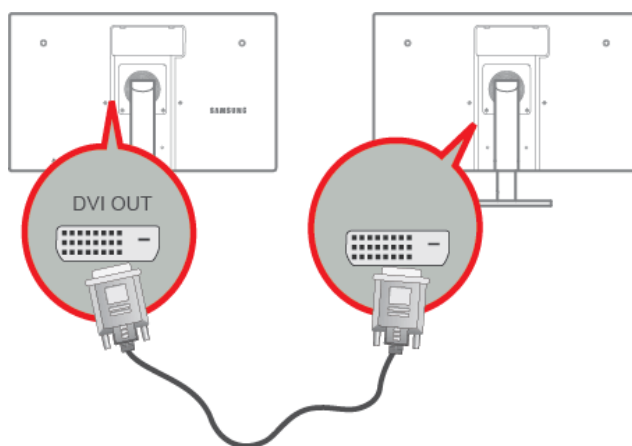

- Connect between the [DVI OUT] port on the product and the DVI port on your monitor using a DVI cable.

 You can connect more monitors via [DVI OUT]. (For presentation purposes).

2-9 Connecting a SERIAL Cable

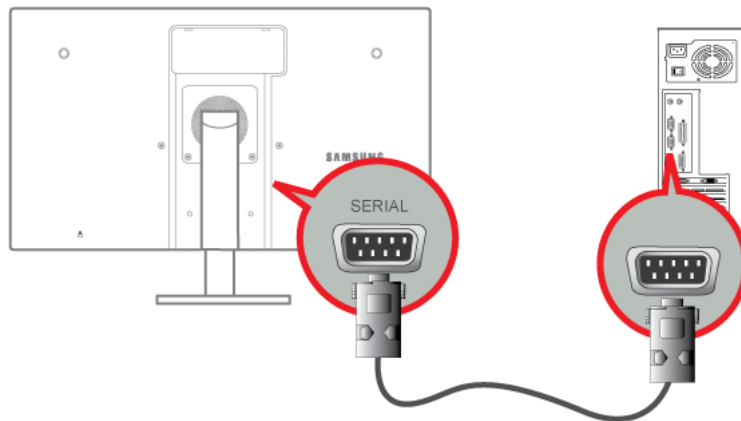

- Devices which support RS-232C connection (interface) can be connected.

2-10 Connecting with a PC

 The connecting part may differ depending on the product model.

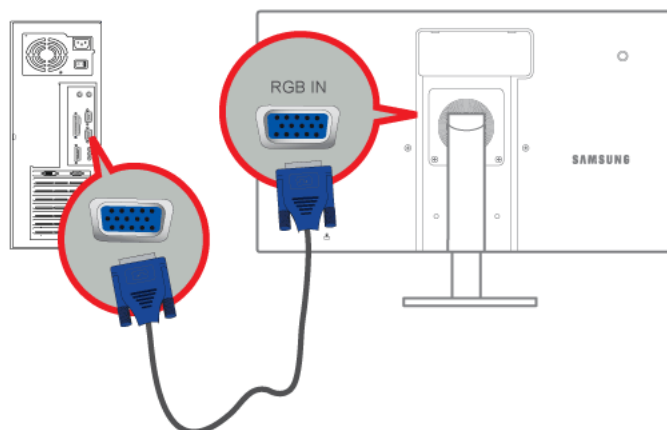

- Connect the [RGB IN] port of the product to the D-Sub port of your PC with a D-Sub cable.

 Use the [RGB IN] port to directly connect the monitor to a PC.

2-11 Connecting a Stereo Cable

 The connecting part may differ depending on the product model.

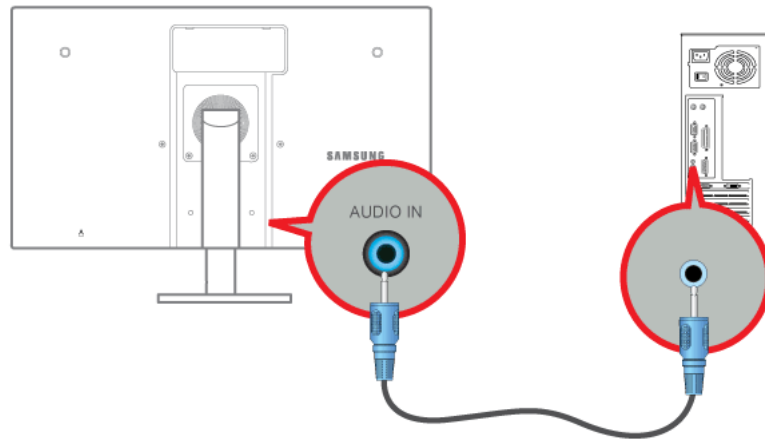

- Connect the [AUDIO IN] port on the rear side of the monitor to the sound card of the PC.

2-12 Connecting Headphones

 The connecting part may differ depending on the product model.

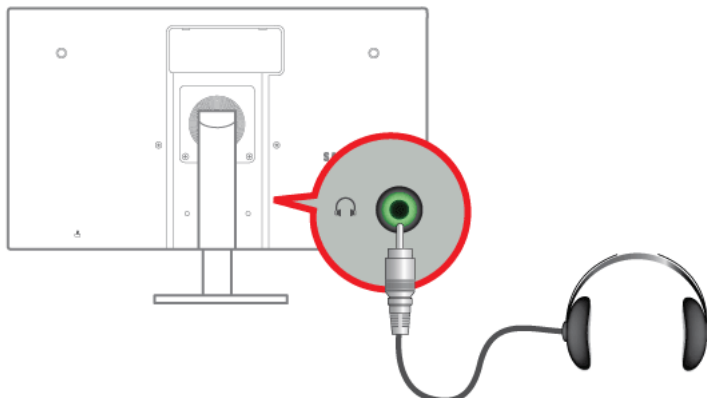

- Connect your headphones to the Headphone connection terminal.

 You may connect your headphones to the monitor.

2-13 Connecting MIC

 The connecting part may differ depending on the product model.

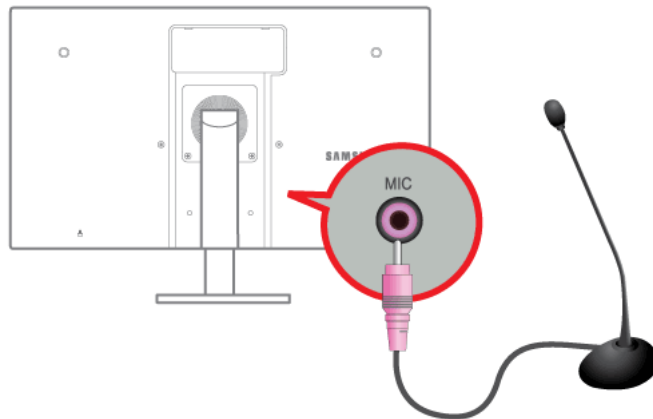

- Connect the microphone cable to the MIC port on the monitor.

 You may connect your microphone to the monitor.

2-14 Kensington Lock

An anti-theft lock allows you to use the product securely even in public places.

The locking device shape and locking method depend on the manufacturer. Refer to the user guide provided with your anti-theft locking device for details.

The lock device is sold separately.

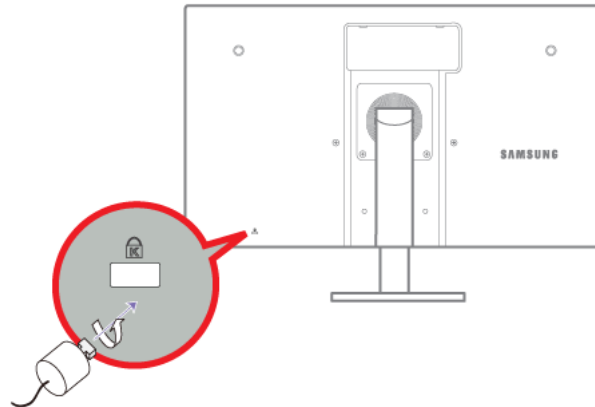

To lock an anti-theft locking device:

1. Fix the cable of your anti-theft locking device to a heavy object such as a desk.
2. Put one end of the cable through the loop on the other end.
3. Insert the locking device into the anti-theft lock slot at the back of the product.
4. Lock the locking device.

- An anti-theft locking device can be purchased separately.
- Refer to the user guide provided with your anti-theft locking device for details.
- Anti-theft locking devices can be purchased at electronics retailers or online.

3 Using the product

3-1 What is a PC over IP?

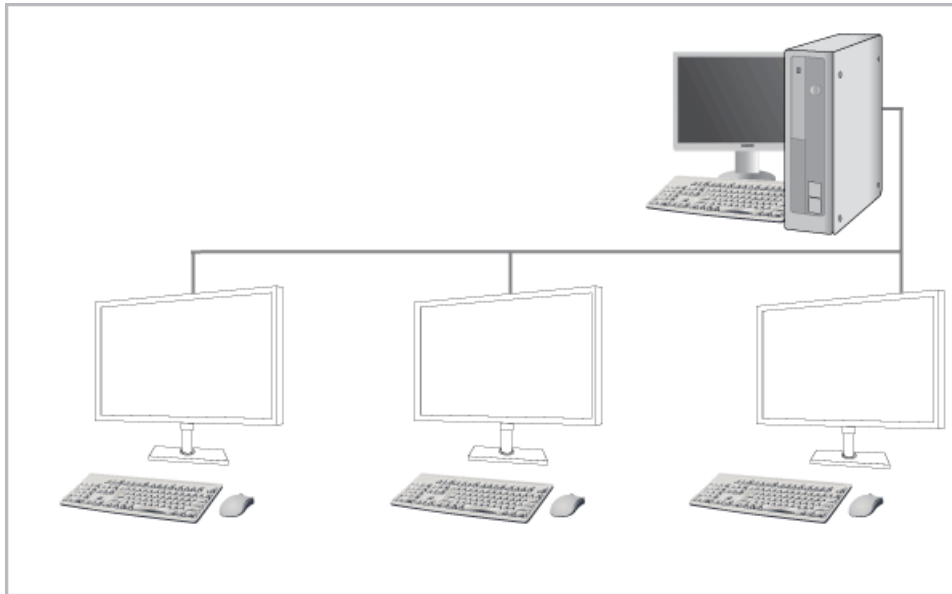

- This monitor can decode and display the screen of the server PC encoded and transmitted through the network (LAN) as well as display the computer screen like a conventional monitor. This monitor shows a far more improved performance than a normal RDP and has been designed to support a resolution of 1920*1080 pixels for high-quality graphic work.
- This monitor enables reinforced security because it is used by connecting it to a server PC and enabling you to access the Internet, create documents and edit figures. In addition, this new-concept monitor enables you to play music, videos and games by connecting an external input source device such as DSC, MP3, external storage device etc. to the USB port.
- This monitor can be utilized for various fields such as video conferencing and co-working by displaying the network display screen on another display device by connecting the device through the DVI OUT port.

3-2 Connect to the host PC using a LAN cable

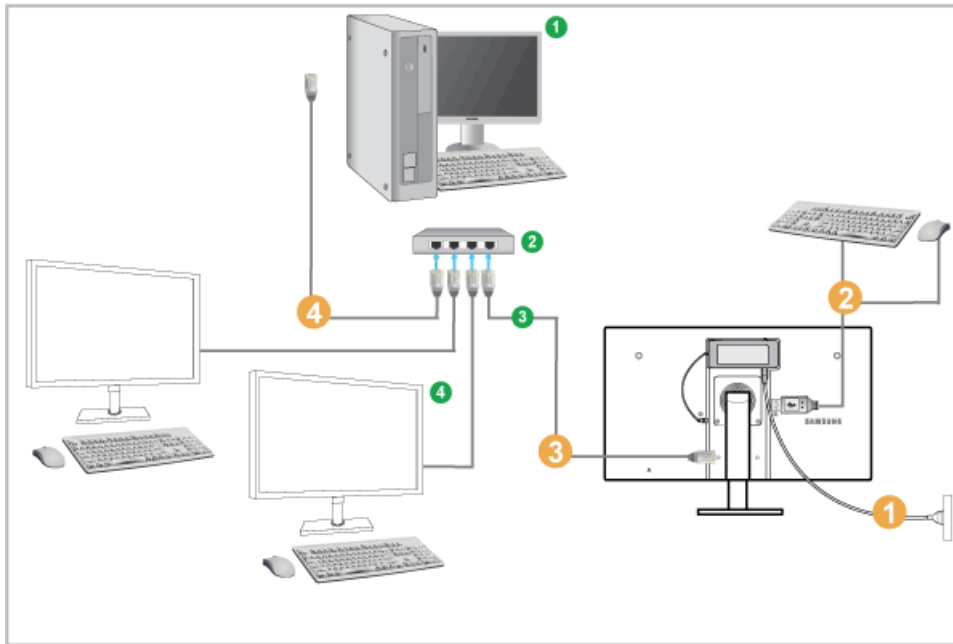

① Host PC

② Hub

③ LAN Cable

④ Monitor

- ① Connect the power cord to the power terminal at the back of the monitor.
- ② Connect the mouse and the keyboard to the USB ports.
- ③ Connect the LAN port on the back of the monitor and the hub.
- ④ Connect the hub and the LAN port of the host PC.

🔑 The host PC must have an IP address.

After connecting the LAN and setting the IP address, you can view the host PC screen on the monitor.

Use the USB port to connect an external storage device (DSC, MP3, external storage, etc.).

Connecting one Host PC to many client device is possible only when virtualization solution like vmware is installed in Host PC.

3-2-1 Connecting USB

- The connecting part may differ depending on the product model.
- The  port supports up to USB 2.0.

VMware View 4.6 or later is required. Data transfer rate may decrease depending on the network conditions.

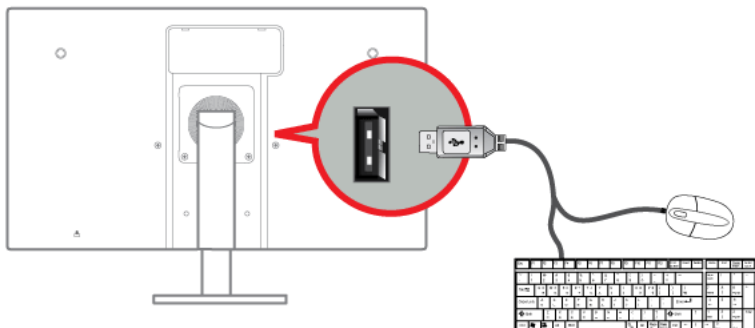

- Connect USB devices such as a mouse, keyboard and external storage devices (DSC (Digital Still Camera), MP3, external storage, etc.).
 - You can use a USB device such as a mouse, keyboard, Memory Stick, or external hard disk drive by connecting them to the  USB port of the monitor without connecting them to the PC. A USB device can be connected and used in this port in Client mode only.

3-3 Plug & Play

If you turn the power on after purchasing the product, a message regarding the optimal resolution setting appears on the screen. Select a language and the optimal resolution.

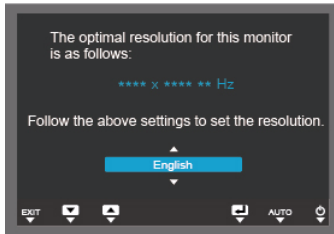

▲/▼ : You can select a language with these buttons.

MENU : If you press this button, the message disappears.

- The message appears up to 3 times if the resolution has not been set to the optimal resolution.
- To set the resolution to the optimal resolution.
 - When the PC is turned off, connect the product and the PC and turn the power on.
 - Right-click over the Desktop and select 'Properties' from the pop-up menu.
 - In the 'Settings' tab, set the resolution to the optimal resolution.

3-4 Standard Signal Mode Table

- The monitor has one optimal resolution for the best visual quality depending on the screen size due to the inherent characteristics of the panel, unlike for a CDT monitor.

Therefore, the visual quality will be degraded if the optimal resolution is not set for the panel size. It is recommended setting the resolution to the optimal resolution of the product.

If the signal from the PC is one of the following standard signal modes, the screen is set automatically. However, if the signal from the PC is not one of the following signal modes, a blank screen may be displayed or only the Power LED may be turned on. Therefore, configure it as follows, referring to the User Manual of the graphics card.

DISPLAY MODE	HORIZONTAL FREQUENCY (KHZ)	VERTICAL FREQUENCY (HZ)	PIXEL CLOCK (MHZ)	SYNC POLARITY (H/V)
IBM, 640 x 350	31.469	70.086	25.175	+/-
IBM, 720 x 400	31.469	70.087	28.322	-/+
MAC, 640 x 480	35.000	66.667	30.240	-/-
MAC, 832 x 624	49.726	74.551	57.284	-/-
MAC, 1152 x 870	68.681	75.062	100.000	-/-
VESA, 640 x 480	31.469	59.940	25.175	-/-
VESA, 640 x 480	37.861	72.809	31.500	-/-
VESA, 640 x 480	37.500	75.000	31.500	-/-
VESA, 800 x 600	35.156	56.250	36.000	+/+
VESA, 800 x 600	37.879	60.317	40.000	+/+
VESA, 800 x 600	48.077	72.188	50.000	+/+
VESA, 800 x 600	46.875	75.000	49.500	+/+
VESA, 1024 x 768	48.363	60.004	65.000	-/-
VESA, 1024 x 768	56.476	70.069	75.000	-/-
VESA, 1024 x 768	60.023	75.029	78.750	+/+
VESA, 1152 x 864	67.500	75.000	108.000	+/+
VESA, 1280 x 800	49.702	59.810	83.500	-/+
VESA, 1280 x 800	62.934	74.934	106.500	-/+
VESA, 1280 x 960	60.000	60.000	108.000	+/+
VESA, 1280 x 1024	63.981	60.020	108.000	+/+
VESA, 1280 x 1024	79.976	75.025	135.000	+/+
VESA, 1440 x 900	55.935	59.887	106.500	-/+
VESA, 1440 x 900	70.635	74.984	136.750	-/+
VESA, 1680 x 1050	65.290	59.954	146.250	-/+

Horizontal Frequency

The time taken to scan one line from the left-most position to the right-most position on the screen is called the horizontal cycle and the reciprocal of the horizontal cycle is called the horizontal frequency. The horizontal frequency is represented in kHz.

Vertical Frequency

A panel must display the same picture on the screen tens of times every second so that humans can see the picture. This frequency is called the vertical frequency. The vertical frequency is represented in Hz.

3-5 Installing the Device Driver

 If you install the device driver, you can set up the appropriate resolution and frequency for the product. The device driver is included on the CD-ROM supplied with the product. If the supplied drive file is corrupted, please visit the Samsung Electronics website(<http://www.samsung.com/>), and download the driver.

1. Insert the driver installation CD-ROM into the CD-ROM drive.
2. Click on "Windows Driver".
3. Complete the remaining installation steps according to the instructions displayed on the screen.
4. Select the model of your product from the model list.

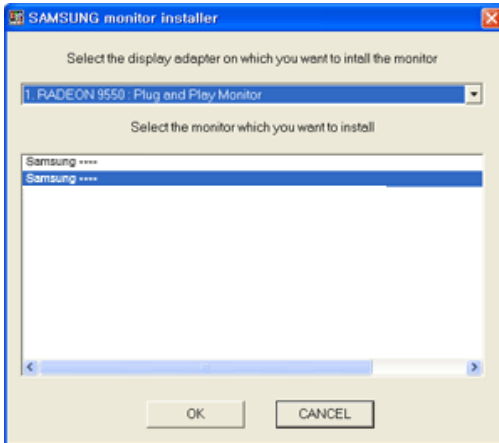

5. Check if the appropriate resolution and screen refresh rate are displayed in the Control Panel settings. For more information, refer to the document about the Windows operating system.

3-6 Installing a USB-to-Serial Driver

 Install the driver on the server PC.

1. Insert the driver installation CD-ROM into the CD-ROM drive.
2. Click on "USB-SERIAL Driver".
3. Click Next.

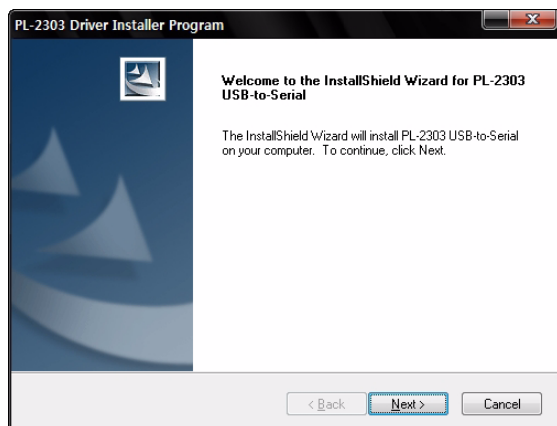



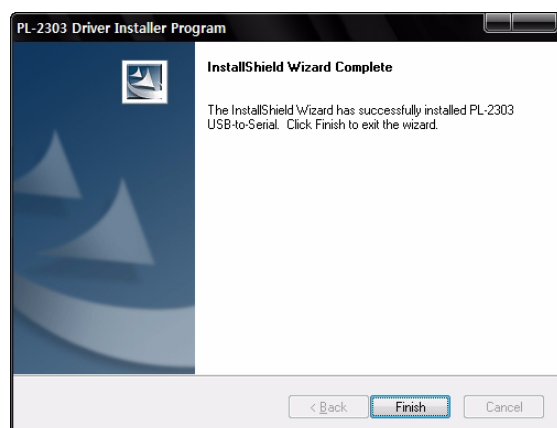





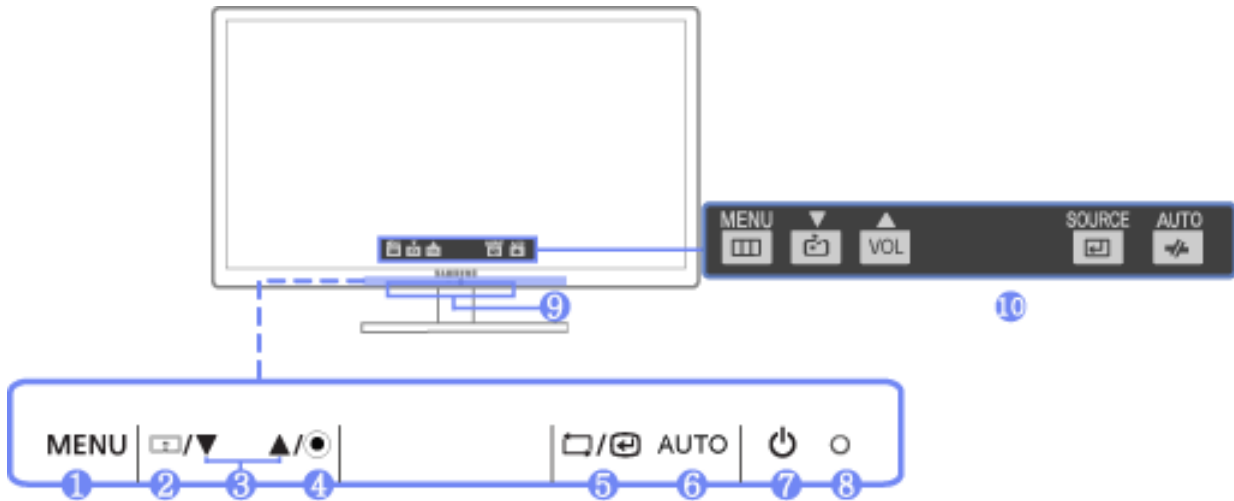

4. Click Finish.



3-7 Product Operating Buttons

Product Operating Buttons



	Icon	Description
1	MENU	<p>Press this button to view the On Screen Display (OSD). This button is also used to exit the OSD or to return to a higher-level OSD menu</p> <p>* Key Lock</p> <p>This function locks the buttons on the front of the product to prevent the current settings from being changed by others.</p> <p>Lock: Press and hold the MENU button for 5 seconds. The key lock mode will be enabled.</p> <p>Unlock: Press and hold the MENU button for 5 seconds when the key lock is enabled. The key lock mode will be disabled.</p> <p> When the key lock mode is enabled, all the buttons on the front of the product are disabled.</p>
2		Press the button at least 2sec to connect to the host PC in Client mode. In order to turn the host PC off, press the button more than 2 sec, being connected to the host PC.
3	▲/▼	Use these buttons to navigate the menu or to adjust a value in the OSD.
4		When OSD is not on the screen, push the button to adjust volume.
5		Use this button to select a function Press [] to select the video signal from a connected device while the OSD is off. (When the [] button is pressed to change the input mode, a message appears in the upper left of the screen displaying the current mode).
6	AUTO	In <Analog> mode, this button is used for auto adjustments. In <Client> mode, it is used to disconnect from the server.
7		Press this button to turn the product on or off
8	 (Power LED)	<p>This LED is turned on when the product works normally.</p> <p> For more information on the power-saving function, refer to the power saving function in More Information. When not using the product for a long time, unplugging the power cord is recommended to minimize power consumption.</p>

	Icon	Description
9	Speaker	 If the 11th digit of the model code is M, the model has internal speakers. E.g.) LF22NEBHBMEN
10	OSD Guide	<ul style="list-style-type: none"> • Press one of the buttons on the monitor. OSD Guide will appear on the screen. • If you press a button on the front of the monitor, an OSD Guide will display showing the function of the button before the menu for the pressed button appears. • To go to the menu, press the button on the front of the monitor again. • OSD Guide may vary according to functions and models. Please refer to actual product.

3-8 Using the Screen Adjustment Menu (OSD: On Screen Display)

The Screen Adjustment Menu (OSD: On Screen Display) Structure



Top Menu	Sub Menu				
PICTURE	Brightness	Contrast	Sharpness	SAMSUNG MAGIC Bright	Coarse
	Fine				
COLOR	SAMSUNG MAGIC Color	Red	Green	Blue	Color Tone
	Gamma				
SIZE & POSITION	H-Position	V-Position	Menu H-Position	Menu V-Position	
SETUP&RESET	Reset	Language	Display Time	Menu Transparency	
INFORMATION	-				

Monitor functions may vary according to models. Please refer to actual product.

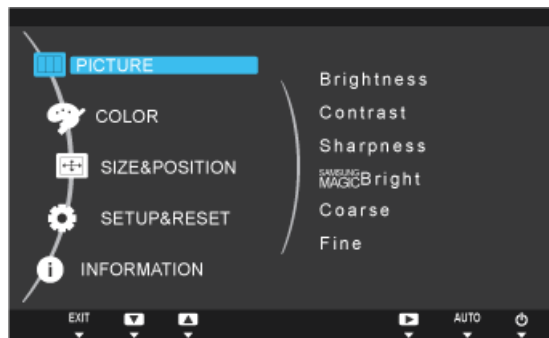
PICTURE





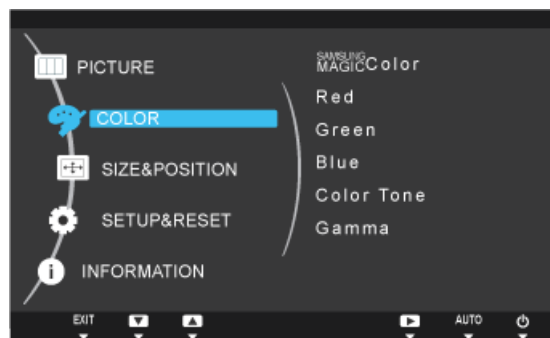

Menu	Description
Brightness	Controls the screen brightness. This menu is unavailable when <SAMSUNG MAGIC Bright> is set to <Dynamic Contrast> mode.
Contrast	Controls the contrast of the pictures displayed on the screen. This menu is unavailable when <SAMSUNG MAGIC Bright> is set to <Dynamic Contrast> mode. This menu is unavailable when <SAMSUNG MAGIC Color> is set to <Full> mode or <Intelligent> mode.
Sharpness	Controls the clarity of details of pictures displayed on the screen. This menu is unavailable when <SAMSUNG MAGIC Bright> is set to <Dynamic Contrast> mode. This menu is unavailable when <SAMSUNG MAGIC Color> is set to <Full> mode or <Intelligent> mode.

Menu	Description
<p>SAMSUNG MAGIC Bright</p>	<p>Provides preset picture settings optimized for various user environments such as editing a document, surfing the Internet, playing games, watching sports or movies and so on.</p> <ul style="list-style-type: none"> • <Custom> If the preset picture modes are not sufficient, you can configure the <Brightness> and <Contrast> directly using this mode. • <Standard> This mode provides the picture setting appropriate for surfing the Internet (text + picture). • <Game> This mode provides the picture setting appropriate for playing games that include lots of graphics and that require a fast screen refresh rate. • <Cinema> This mode provides brightness and sharpness settings similar to those of a TV for the best entertainment environment (movie, DVD, etc.). • <Dynamic Contrast> Controls the picture contrast automatically so that bright and dark pictures are balanced overall.
<p>Coarse</p>	<p>Removes vertical noise lines (line pattern) from the screen.</p> <p>The location of the screen may be changed after the adjustment. In this case, move the screen so that the screen is displayed at the center of the display panel using the <H-Position> menu.</p> <p> This function is only available in <Analog> mode.</p>
<p>Fine</p>	<p>Removes horizontal noise lines (line pattern) from the screen.</p> <p>If you cannot remove the noise completely with the <Fine> function, adjust the <Coarse> and then use the <Fine> function again.</p> <p> This function is only available in <Analog> mode.</p>

 **COLOR**





Menu	Description
SAMSUNG MAGIC Color	<p>Expresses natural colors more clearly without changing the picture quality by using proprietary digital picture quality improvement technology developed by Samsung Electronics.</p> <ul style="list-style-type: none"> • <Off> - Turns the <SAMSUNG MAGIC Color> function off. • <Demo> - You can compare the pictures processed by <SAMSUNG MAGIC Color> with the original pictures. • <Full> - Provides a clearer picture including areas corresponding to skin color. • <Intelligent> - Improves the chroma of pictures except for areas corresponding to skin color.
Red	<p>You can adjust the red color value according to your preference.</p> <p> This menu is unavailable when <SAMSUNG MAGIC Color> is set to <Full> mode or <Intelligent> mode.</p>
Green	<p>You can adjust the green color value according to your preference.</p> <p> This menu is unavailable when <SAMSUNG MAGIC Color> is set to <Full> mode or <Intelligent> mode.</p>
Blue	<p>You can adjust the blue color value according to your preference.</p> <p> This menu is unavailable when <SAMSUNG MAGIC Color> is set to <Full> mode or <Intelligent> mode.</p>
Color Tone	<p>You can set the color temperature according to your preference.</p> <ul style="list-style-type: none"> • <Cool 2> - Sets the color temperature of the screen to very cool. • <Cool 1>- Sets the color temperature of the screen to cool. • <Normal> - Sets the color temperature of the screen to the standard color temperature. • <Warm 1> - Sets the color temperature of the screen to warm. • <Warm 2> - Sets the color temperature of the screen to very warm. • <Custom> - Select this menu to set the color temperature manually. <p>If you do not like the preset color temperatures, you can manually adjust the value of RGB.</p> <p> • This menu is unavailable when <SAMSUNG MAGIC Color> is set to <Full> mode or <Intelligent> mode.</p>
Gamma	<p>Using this menu, you can change the intensity of the colors of medium brightness.</p> <ul style="list-style-type: none"> • <Mode1> - <Mode2> - <Mode3>

 This is unavailable when <SAMSUNG MAGIC Bright> is set to <Dynamic Contrast> or <Cinema> mode.

SIZE & POSITION



Menu	Description
H-Position	Moves the position of the display area on the screen horizontally.  This function is only available in <Analog> mode.
V-Position	Moves the position of the display area on the screen vertically.  This function is only available in <Analog> mode.
Menu H-Position	You can adjust the horizontal position of the OSD.
Menu V-Position	You can adjust the vertical position of the OSD.

SETUP&RESET

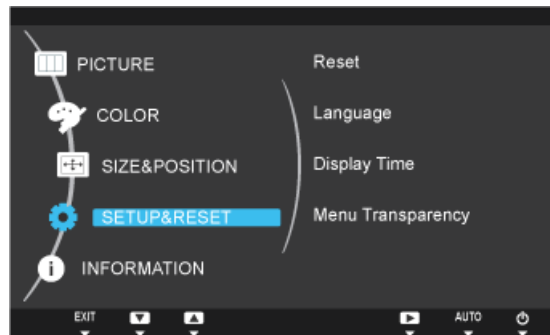

Menu	Description
Reset	Use this function to restore the visual quality and color settings to the factory defaults. <ul style="list-style-type: none"> <No> - <Yes>
Language	Select a language for the OSD. English, Deutsch, Español, Français, Italiano, Magyar, Polski, Português, Русский, Svenska, Türkçe, 日本語, 한국어, 汉语  The selected language is only applied to the product OSD. This setting does not affect the other functions of the PC.
Display Time	The OSD automatically disappears if no action is taken by the user. You can determine the time to wait before the OSD is hidden. <ul style="list-style-type: none"> <5 sec> - <10 sec> - < 20 sec> - <200 sec>
Menu Transparency	You can select the transparency of the OSD. <ul style="list-style-type: none"> <Off> - <On>

INFORMATION

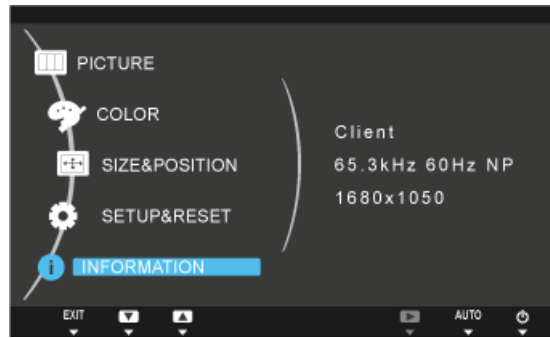

Menu	Description
INFORMATION	Shows the frequency and resolution set on the PC.  For models with an Analog interface only, <Analog/Digital> is not shown in the <Information>.

4 Installing the Software

4-1 PCoIP

On Screen Display (OSD)

The On Screen Display (OSD) local GUI is displayed to the user when the device is powered on and a PCoIP session is not in progress.

The OSD provides a mechanism to connect to a host device via the Connect Screen. The Connect Screen is presented to the user on startup.

The Connect Screen also allows access to the Options Window.

The Options Window is accessible through the <Options> button on the Connect Screen. An administrative password is required to change Portal options.

Connect Screen

The Connect Screen is shown on startup except when the Portal has been configured for a managed start-up or auto-reconnect.

The logo displayed above the <Connect> button can be changed by uploading a replacement image via the Administrative Web Interface.

Figure 2-1: OSD Connect Screen

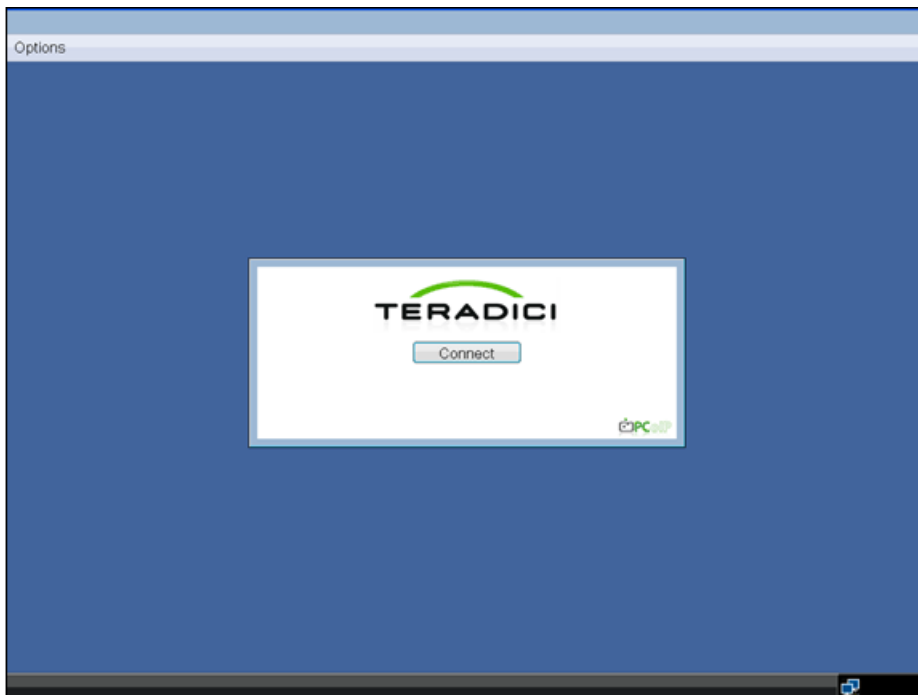

Connect Button

Selecting the Connect button initiates a PCoIP or RDP session, depending on the session settings. While the PCoIP connection is pending, the OSD local GUI will display a “Connection Pending” message. When the connection is established, the OSD local GUI will disappear and be replaced with the session image.

Figure 2-2: OSD Connect Screen (Connecting)

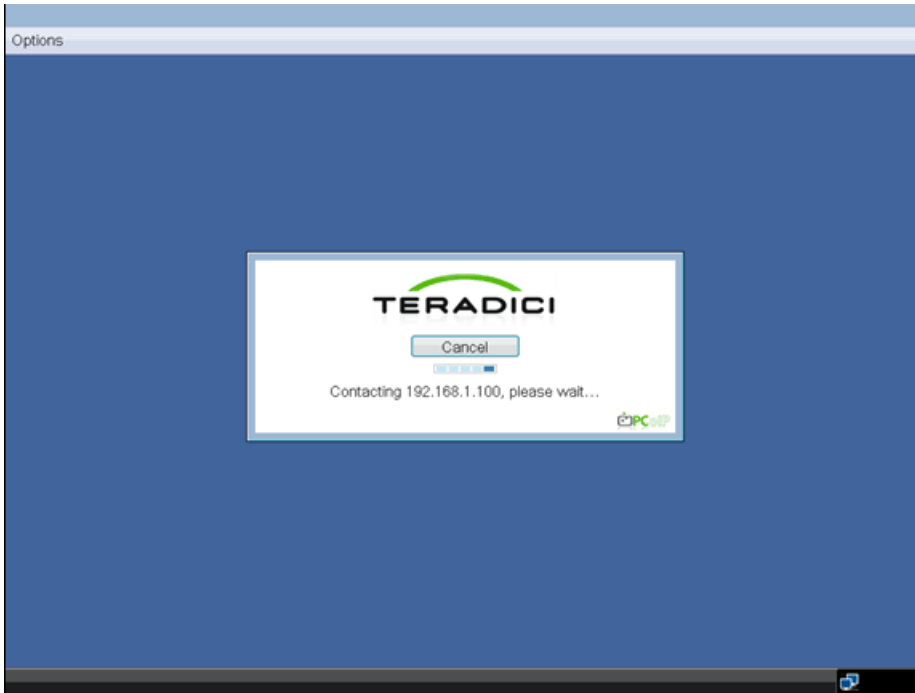

OSD <Options> Menu

Selecting the <Options> menu will produce a list of selections. The OSD <Options> menu contains:

- <Configuration>
- <Diagnostics>
- <Information>
- <User Settings>
- <Password>

Selecting one of the selections will produce a settings window.

Figure 2-3: OSD <Options> Menu

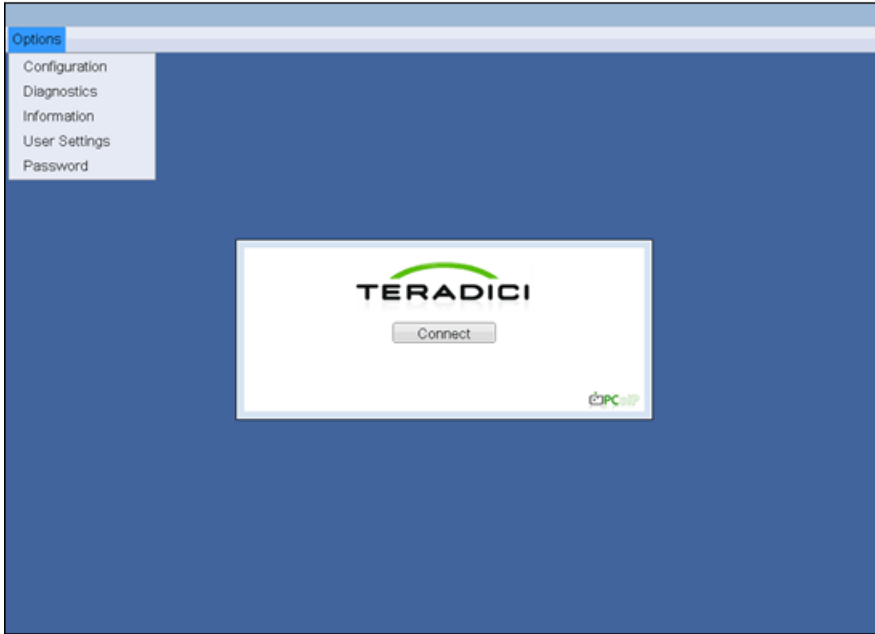

<Configuration> Window

The <Configuration> window allows the administrator to access window tabs with settings that define how the Portal operates and interacts with its environment.

The tabs in the <Configuration> window are:

- <Network>
- <Label>
- <Connection Management>
- <Discovery>
- <Session>
- <RDP>
- <Language>
- <OSD>
- <Reset>
- <VMware View>

Each tab has <OK>, <Cancel>, and <Apply> buttons that allow the administrator to accept or cancel the setting changes made on the tab.

- 🔑 Some PCoIP devices have password protection disabled and do not require a password to login into the administration webpages or access the OSD parameters. Password protection for the Log In page and OSD can be enabled through PCoIP Management Console.

<Network> Tab

The <Network> tab allows an administrator to set the Portal network parameters.

- 🔑 The Network parameters can also be configured using the Webpage Administration Interface.

Figure 2-4: <Network> Configuration

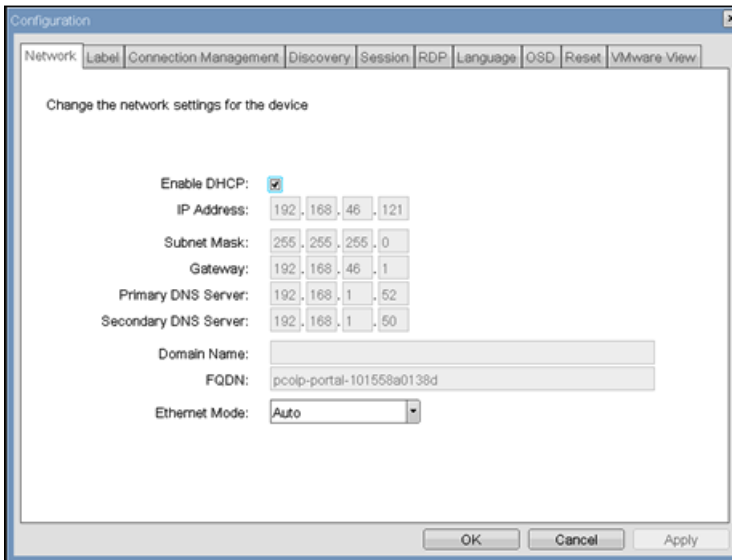

- <Enable DHCP>
When <Enable DHCP> is enabled, the device will contact a DHCP server to be assigned an IP address, subnet mask, gateway IP address and DNS servers. When disabled, the device requires these parameters to be set manually.
 - <IP Address>
The IP Address field is the device's <IP address>. If DHCP is disabled, this field is required. If DHCP is enabled, this field is not editable. This field must be a valid IP address, and if an invalid IP address is entered, the OSD will prompt the administrator to correct it.
 - <Subnet Mask>
The <Subnet Mask> field is the device's subnet mask. If DHCP is disabled, this field is required.
If DHCP is enabled, this field is not editable. This field must be a valid subnet mask, if an invalid subnet mask is entered, the OSD will prompt the administrator to correct it.
 - <Gateway>
The <Gateway> field is the device's gateway IP address. If DHCP is disabled, this field is required. If DHCP is enabled, this field is not editable.
 - <Primary DNS Server>
The <Primary DNS Server > field is the device's primary DNS IP address. This field is optional. If DHCP is enabled, this field is not editable.
 - <Secondary DNS Server>
The <Secondary DNS Server> field is the device's secondary DNS IP address. This field is optional. If DHCP is enabled, this field is not editable.
 - <Domain Name>
The <Domain Name> is the domain name used, e.g. 'domain.local'. This field is optional. This field specifies the domain that the Host or Portal is on.
 - <FQDN>
The <FQDN> is the Fully Qualified Domain Name for the Host or Portal. The default is pcoip-host-MAC or pcoip-portal-MAC where MAC is the Host or Portal's MAC address. If used, the Domain Name will be appended, e.g. pcoip-host-MAC.domain.local.
 - <Ethernet Mode>
The <Ethernet Mode> field configures the Ethernet mode of the Portal. The options are:
 - <Auto>
 - <10 Mbps Full-Duplex>
 - <100 Mbps Full-Duplex>
-  Administrators should always set the <Ethernet Mode> to <Auto> and only use <10 Mbps Full-Duplex> or <100 Mbps Full-Duplex> when the other network equipment, e.g. switch, is also configured to operate at <10 Mbps Full-Duplex> or <100 Mbps Full-Duplex>.

<Label> Tab

The <Label> tab allows an administrator to add custom information for the Host or Portal.

 The Portal Label parameters can also be configured using the Webpage Administration Interface.

Figure 2-5: <Label> Configuration

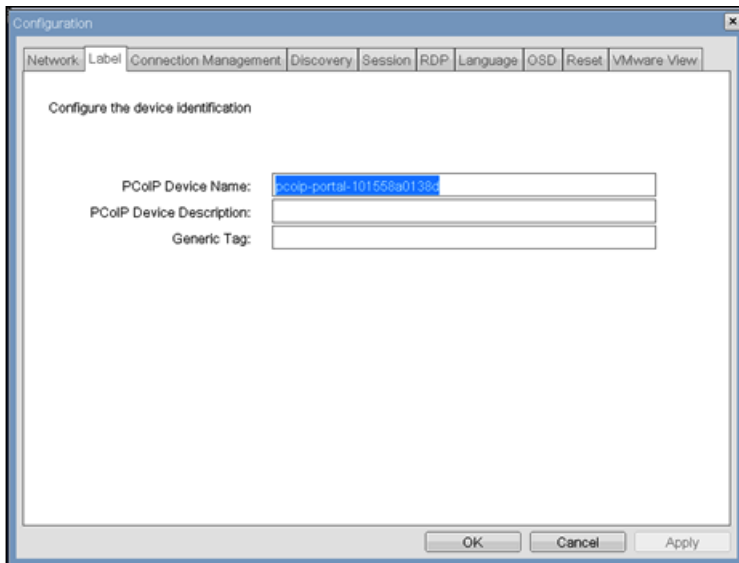

- <PCoIP Device Name>
If the <PCoIP Device Name> allows the administrator to give the Host or Portal a logical name. The default is pcoip-host-MAC or pcoip-portal-MAC where MAC is the Host or Portal's MAC address.
- <PCoIP Device Description>
The <PCoIP Device Description> allows the administrator to give the Host or Portal a description or more information, e.g. location of endpoint, etc.
- <Generic Tag>
The <Generic Tag> allows the administrator to give the Host or Portal a generic tag information.

<Connection Management> Tab

The <Connection Management> tab allows enabling or disabling connection management, and to specify the IP address of the connection manager.

In a managed connection, an external <Connection Manager> Server communicates with and can remotely control and configure the device. Additionally, the connection manager can locate an appropriate peer for the device to connect to and initiate the connection. <Connection management> can greatly simplify the administration effort for a large, complex system.

 The Connection Management parameters can also be configured using the Webpage Administration Interface.

Figure 2-6: <Connection Management> Configuration

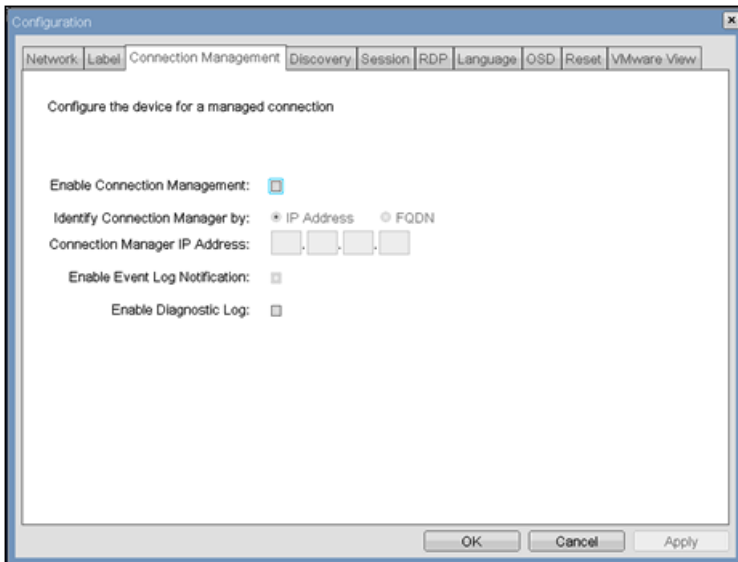

- <Enable Connection Management>
If the <Enable Connection Management> option is enabled, the device can be configured and controlled by an external connection manager.
- <Identify Connection Manager By>
The <Identify Connection Manager By> selector allows the administrator to choose whether the connection manager is identified by <IP address> or by Fully Qualified Domain Name (FQDN). If connection management is disabled, this field is not required and is not editable.
Table 2-1 shows the configuration parameters available when either method is chosen. If an invalid IP address or DNS name is entered, the OSD will prompt the administrator to correct it.

Table 2-1: Connection Manager Method

METHOD	DATA FIELDS
<IP address>	Connection Manager IP Address
<FQDN>	Connection Manager DNS name

- <Enable Event Log Notification>
The <Enable Event Log Notification> field controls whether the PCoIP Host and Portal devices send the contents of their event logs to the connection management server.
- <Enable Diagnostic Log>
The <Enable Diagnostic Log> field controls whether connection management specific debug messages are written to the event log of the PCoIP Host and Portal devices.

<Discovery> Tab

The <Discovery> configuration tab allows the use of features that ease the discovery of Portals in a PCoIP system.

 The Discovery parameters can also be configured using the [Webpage Administration Interface](#).

Figure 2-7: <Discovery> Configuration

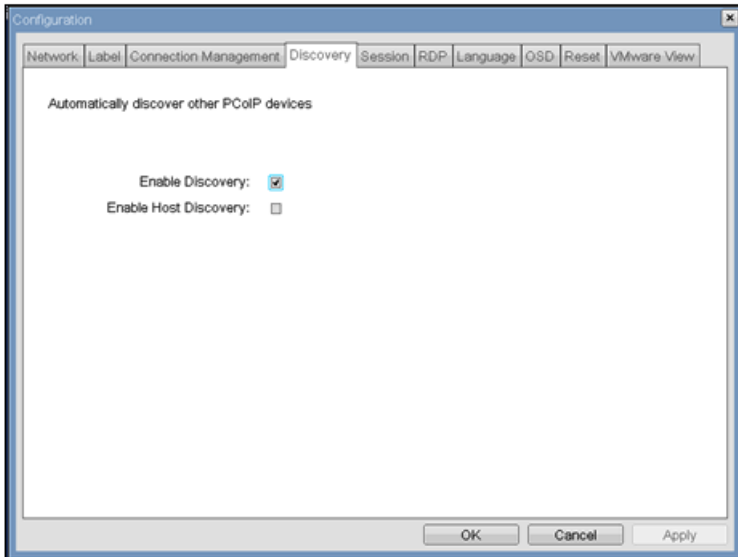

- <Enable Discovery>
If the <Enable Discovery>option is enabled, the device will dynamically discover peer devices using SLP Discovery, without requiring prior knowledge of their locations in the network. This can dramatically reduce configuration and maintenance effort for complex systems.
 - 🔗 SLP discovery requires routers configured to allow multicast, and therefore DNS-SRV Discovery is the recommended discovery mechanism.
- <Enable Host Discovery>
The <Enable Host Discovery>feature allows the Portal to discover Hosts that are not in a PCoIP session. When enabled, the Portal is able to display up to 10 available hosts in order of being discovered. It is expected that the <Enable Host Discovery> feature will be used with small numbers of Hosts.

<Session> Tab

The <Session> tab allows an administrator to configure how the device connects to peer devices.

- 🔗 The Session parameters can also be configured using the Webpage Administration Interface.

Figure 2-8: <Session> Configuration

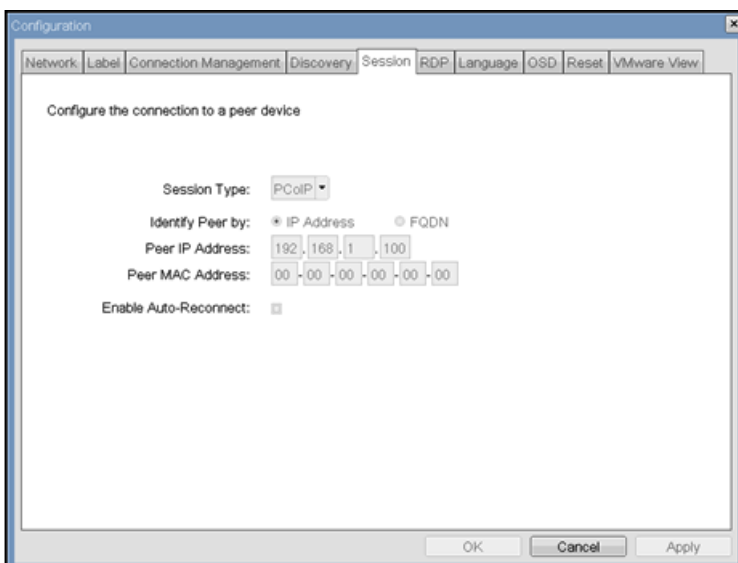

- <Session Type>
The <Session Type> allows the administrator to configure the Portal for a PCoIP session or RDP session.
- <Identify Peer By>
The <Identify Peer By> selector allows the administrator to choose whether the peer device is identified by IP and MAC address or by Fully Qualified Domain Name (FQDN).

Table 2-2 shows the peer identity parameters available when either method is chosen. If an invalid IP address or DNS name is entered, the OSD will prompt the administrator to correct it.

Table 2-2: Peer Identity Methods

PEER IDENTITY METHOD	DATA FIELDS	COMMENT
Peer IP/MAC	Peer IP Address	PCoIP or Portal RDP client
	Peer MAC Address	PCoIP
Peer FQDN	Peer FQDN	PCoIP or Portal RDP client

- <Enable Auto-Reconnect>
The <Enable Auto-Reconnect> option allows the Portal to automatically reconnect with the last connected Host when a session is lost.

<Language> Tab

The <Language> field allows the administrator to configure the language of the OSD.

 The Language parameters can also be configured using the Webpage Administration Interface.

Figure 2-9: <Language> Configuration

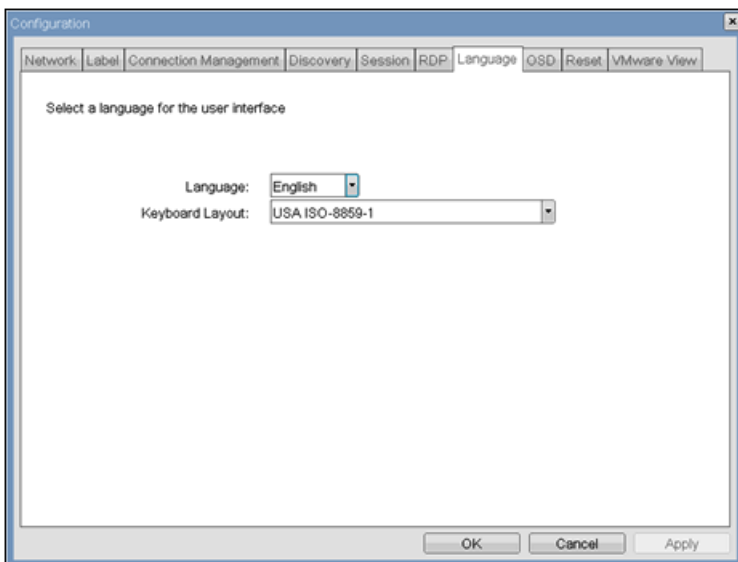

<Language>

The <Language> field can be used to configure the language for the on-screen display and event log messages.

<Keyboard Layout>

The <Keyboard Layout> field allows the administrator to change the keyboard layout.

<Reset> Tab

The <Reset> tab allows the administrator to reset all the configurable parameters stored in flash.

 The Reset can also be initiated using the Webpage Administration Interface.

Figure 2-10: <Reset>

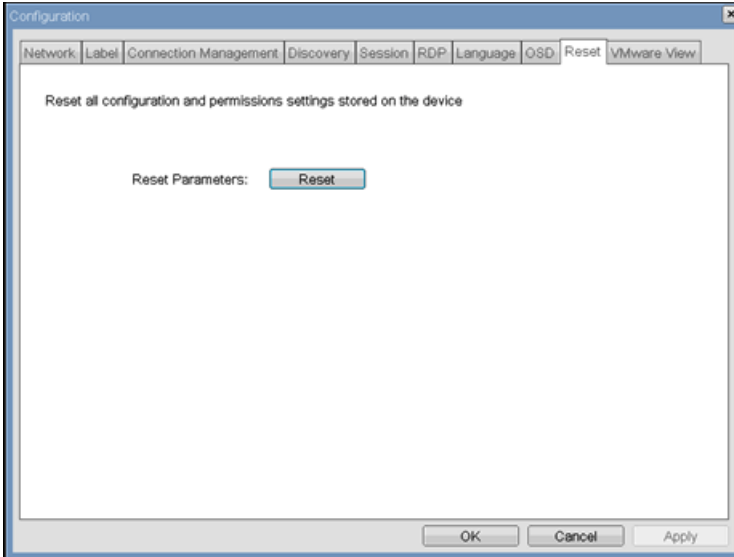

<Reset Parameters>

The <Reset Parameters> <Reset> button resets all configuration and permissions to factory default values.

<VMware View> Tab

The <VMware View> tab allows configuration for use with a VMware View Connection Server.

 The VMware View parameters can also be configured using the Webpage Administration Interface.

Figure 2-11: <VMware View> Configuration

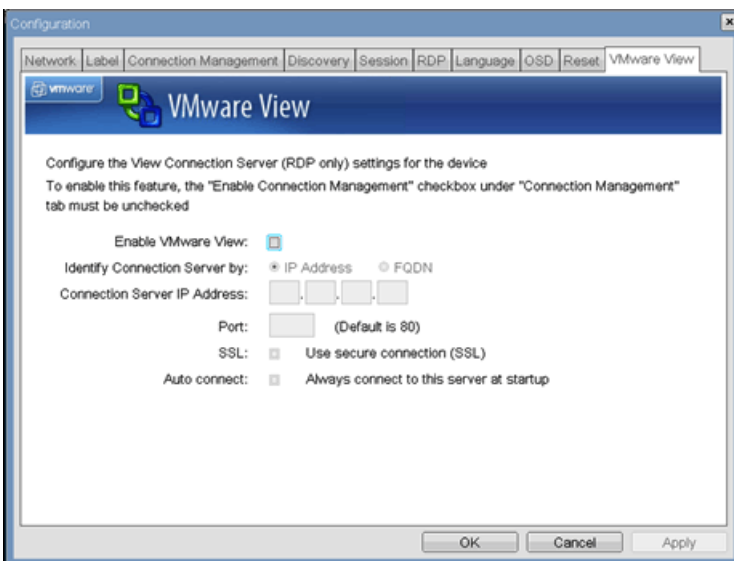

<Enable VMware View>

When the <Enable VMware View> option is enabled, the Portals can be configured for use with a VMware View Connection Server.

 To enable the VMware View feature, the <Connection Management> checkbox on the <Enable Connection Management> tab must be unchecked.

<Identify Connection Server by>

The <Identify Connection Server by> selector allows the administrator to choose whether the connection manager is identified by IP address or by Fully Qualified Domain Name (FQDN). If VMware View is disabled, this field is not required and is not editable.

<Port>

The <Port> parameter allows the administrator to specify the port used to communicate to the VMware View Connection Server.

<SSL>

The <SSL> parameter allows the administrator to specify the <SSL> to communicate with the VMware View Connection Server.

<Auto connect>

The <Auto connect> parameter allows the administrator to specify that the Portal automatically always connects with the VMware View Connection Server at startup.

<Diagnostics> Window

The <Diagnostics> allows the administrator to access window tabs with diagnostics concerning the Portal. The tabs in the <Diagnostics> window are:

- <Event Log>
- <Session Statistics>
- <PCoIP Processor>
- <Ping >

Each tab has a Close button to close the window.

<Event Log> Tab

The <Event Log> tab allows the administrator to view and clear event log messages from the Portal.

 The <Event Log> can also be initiated using the [Webpage Administration Interface](#).

Figure 2-12: <Event Log>

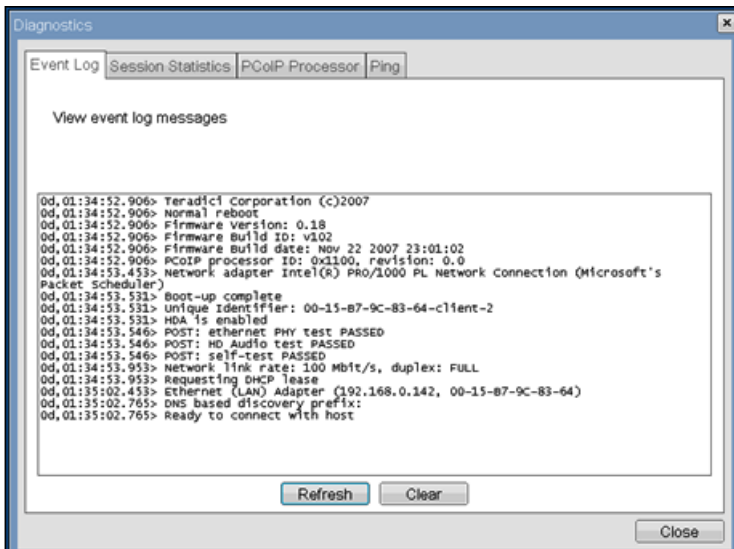

<View event log messages>

The <View event log messages> field displays log messages with time stamp information. There are two associated buttons available.

- <Refresh>
Selecting the <Refresh> button refreshes the event log messages displayed.
- <Clear>

Selecting the <Clear> button clears all of the displayed event log messages.

<Session Statistics> Tab

The <Session Statistics> tab allows the administrator to view PColP-specific statistics for the last PColP session that was active on the Portal.

 <Session Statistics> can also be viewed using the [Webpage Administration Interface](#).

Figure 2-13: <Session Statistics>

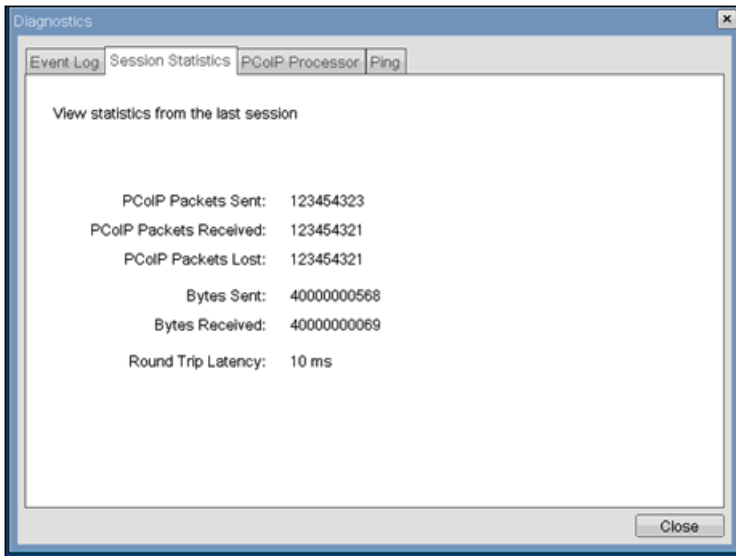

<PCoIP Packets Statistics>

- <PCoIP Packets Sent>
The <PCoIP Packets Sent> field reports the total number of PCoIP packets sent from the Portal to the Host in the last active session.
- <PCoIP Packets Received>
The <PCoIP Packets Received> field reports the total number of PCoIP packets received from the Host to the Portal in the last active session.
- <PCoIP Packets Lost>
The <PCoIP Packets Lost> field reports the total number of PCoIP packets lost in the last active session.

<Bytes Statistics>

- <Bytes Sent>
The <Bytes Sent >field reports the total number of bytes sent in the last active session.
- <Bytes Received>
The <Bytes Received> field reports the total number of bytes received in the last active session.

<Round Trip Latency>

The <Round Trip Latency> field reports the total round-trip PCoIP system (e.g. Portal to Host and back to Portal) and network latency in milliseconds (+/- 1 ms).

<PCoIP Processor> Tab

The <PCoIP Processor> tab allows the administrator to view the uptime of the Portal PCoIP processor since last boot.

 The <PCoIP Processor> Uptime can also be viewed in the [Webpage Administration Interface](#).

Figure 2-14: <PCoIP Processor>

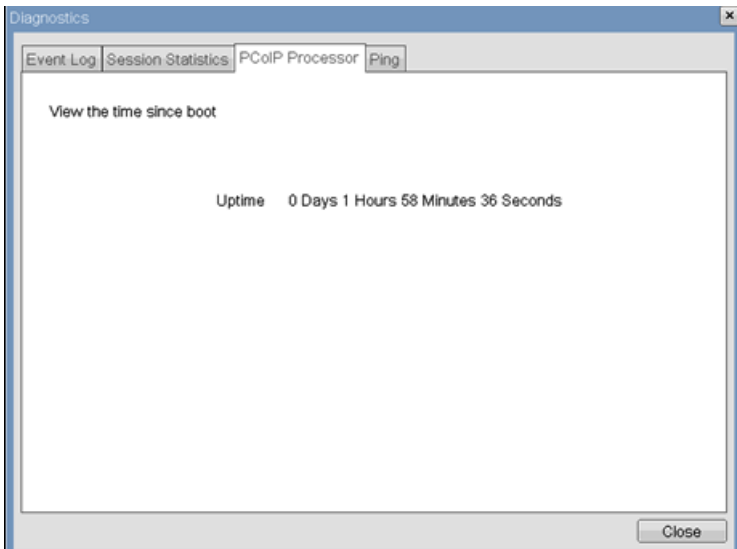

<Ping> Tab

The <Ping> tab allows the administrator to ping a device to see if it is reachable across an IP network. This may be useful for determining if a Host is reachable.

Figure 2-15: <Ping>

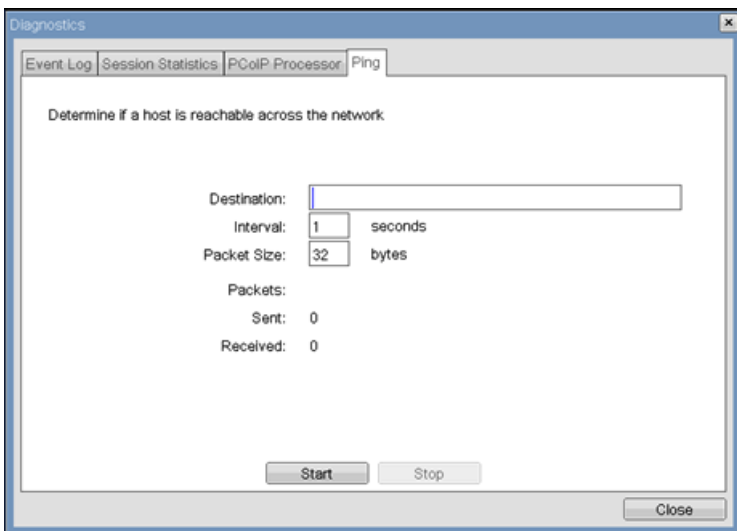

Ping Settings

- <Destination>
IP Address or FQDN to ping
- <Interval>
Interval between ping packets
- <Packet Size>
Size of ping packet

Packets

- <Sent>
Number of ping packets sent
- <Received>
Number of ping packets received

<Information> Window

The <Information> window allows an administrator to access the Version tab containing information about the device.

-  The Version information can also be viewed using the Webpage Administration Interface.

Figure 2-16: <Version>

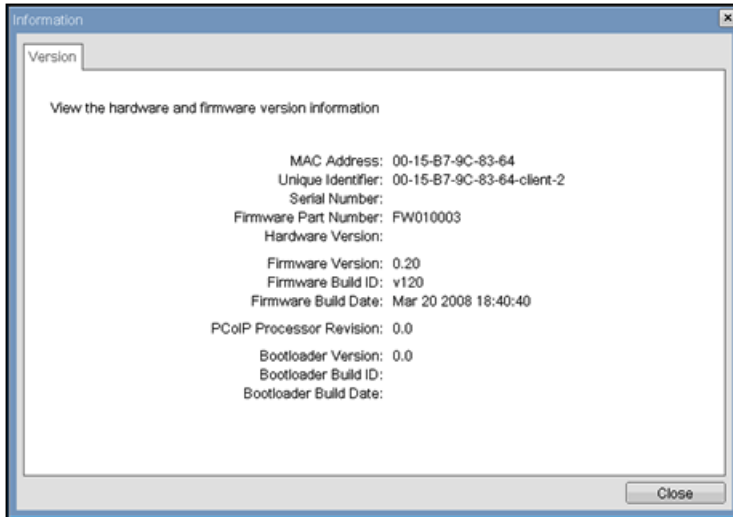

VPD Information

Vital Product Data (VPD) is information provisioned by the factory to uniquely identify each Portal or Host.

- <MAC Address>
Portal unique <MAC address>
- <Unique Identifier>
Portal unique identifier
- <Serial Number>
Portal unique serial number
- <Firmware Part Number>
Part number of PCoIP firmware
- <Hardware Version>
Portal hardware version number

Firmware Information

The <Firmware Information> reflects the current PCoIP firmware details.

- <Firmware Version>
Version of the current PCoIP firmware
- <Firmware Build ID>
Revision code of the current PCoIP firmware
- <Firmware Build Date>
Build date of the current PCoIP firmware

<PCoIP Processor Revision>

The <PCoIP Processor Revision> Revision field reports the PCoIP Processor Revision code. TERA1x00 Revision A silicon is denoted by 0.0 and TERA1x00 Revision B silicon is denoted by 1.0.

Bootloader Information

The Bootloader information reflects the current PCoIP bootloader details.

- <Bootloader Version>
Version of the current PCoIP bootloader
- <Bootloader Build ID>

Revision code of the current PCoIP bootloader

- <Bootloader Build Date>

Build date of the current PCoIP bootloader

<User Settings> Window

The <User Settings> window allows the user to access window tabs that define the mouse and keyboard settings and the PCoIP image quality.

The tabs in the User Settings menu are:

- <Mouse>
- <Keyboard>
- <Image>

<Mouse> Tab

The <Mouse> tab allows a user to change the mouse cursor speed settings for the OSD and RDP sessions.

-  The OSD mouse cursor speed setting does not affect the mouse cursor settings when a PCoIP session is active unless the Local Keyboard Host Driver function is being used (see PCoIP Host Software User Guide for more information).

Figure 2-17: <Mouse>



- <Mouse Speed>

The <Mouse Speed> field allows the Portal mouse cursor speed to be configured.

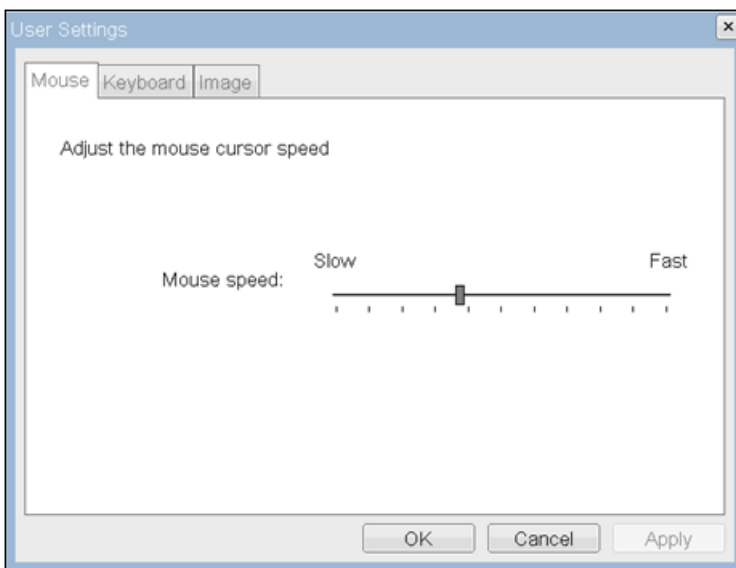
-  The <Mouse Speed> can also be configured via the PCoIP Host Software. For more information on using the PCoIP Host Software, refer to the PCoIP Host Software User Guide for more information.

<Keyboard> Tab

The <Keyboard> tab allows a user to change the keyboard repeat settings for the OSD and RDP sessions.

-  The keyboard settings do not affect the keyboard settings when a PCoIP session is active unless the Local Keyboard Host Driver function is being used (see PCoIP Host Software User Guide for more information).

Figure 2-18: <Keyboard>



- <Keyboard Repeat Delay >
The <Keyboard Repeat Delay> field allows a user to configure the Portal keyboard repeat delay.
- <Keyboard Repeat Rate>
The <Keyboard Repeat Rate> field allows a user to configure the Portal keyboard repeat rate.
- <Repeat Settings Test Box >
The <Repeat Settings Test Box> field allows a user to test the chosen keyboard settings.

<Image>

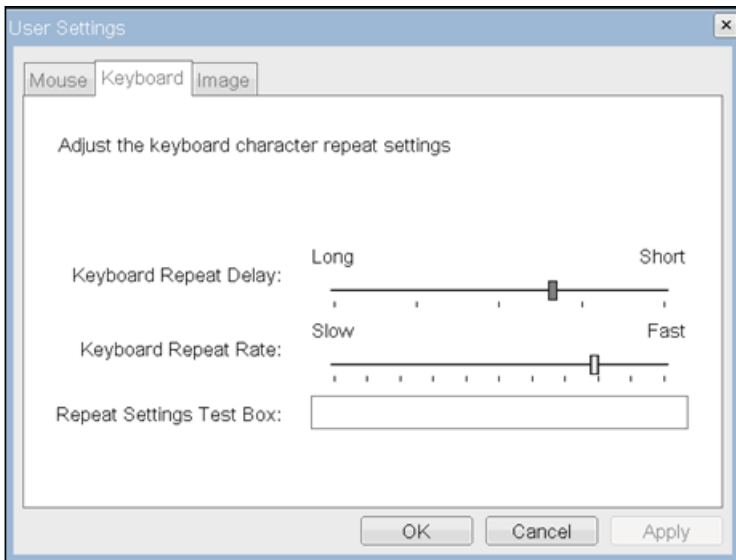
The <Image> allows a user to change the image settings on the PCoIP system.

 The Image parameters can also be configured using the Webpage Administration Interface.

Figure 2-19: <Image>

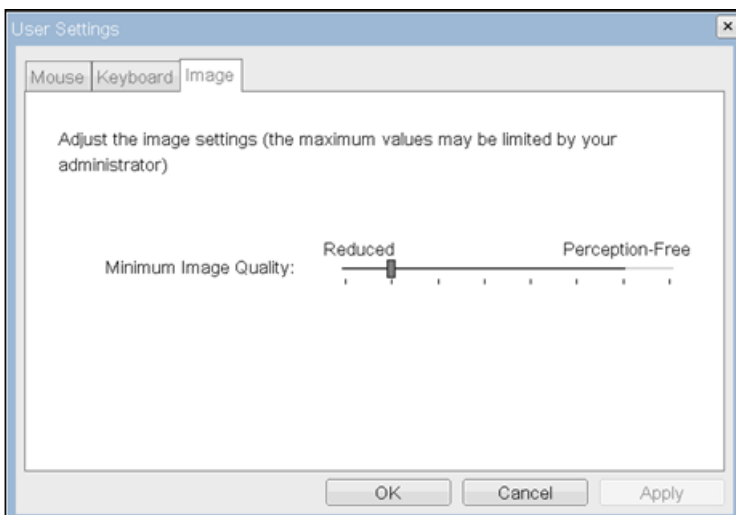

- <Minimum Image Quality>
The <Minimal Image Quality> slider allows a user to make compromises between image quality and frame rate when network bandwidth is limited. Some usage cases may require lower-quality images at a higher frame rate, while in other cases higher-quality images at a lower frame rate may be preferred.
Moving the slider toward <Reduced> when the network bandwidth is constrained will degrade the image quality. When network bandwidth is not constrained, the PCoIP system will maintain <perception-free> quality regardless of the <Minimum Image Quality> setting.

<Password> Window

The <Password> window allows an administrator to update the administrative password for the device. Note that this will affect the web interface and the local <OSD> GUI.

- Care must be taken when updating the Portal Password as the Portal may become unusable if the password is lost.
- The Password can also be updated using the Webpage Administration Interface.
- Some PCoIP devices have password protection disabled by default and this <Password> window is not available. Password protection can be enabled through PCoIP Management Console.

Figure 2-20: <Change Password>

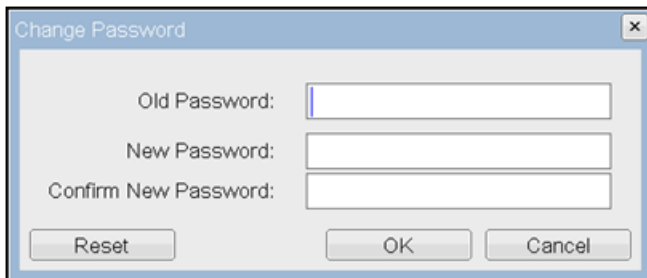

- <Old Password>
The <Old Password> field must match the current administrative password for the change to take place.
- <New Password>
The <New Password> field will be the new administrative password for both the web interface and the local OSD GUI.
- <Confirm New Password>
The <Confirm New Password> field must match the <New Password> field for the change to take place.
- <Reset>
In the unlikely event that a Portal password is lost, the <Reset> button allows an administrator to request a Response code from their vendor. The Challenge code can be sent to the vendor. The vendor will qualify the request and return a Response code if authorized.
Once the Response code is correctly entered, the Portal's password is reset to an empty string and the administrator is prompted to enter a new password.

- Contact the Portal vendor for more information when an authorized password reset is required.

Figure 2-21: <Authorized Password Reset>

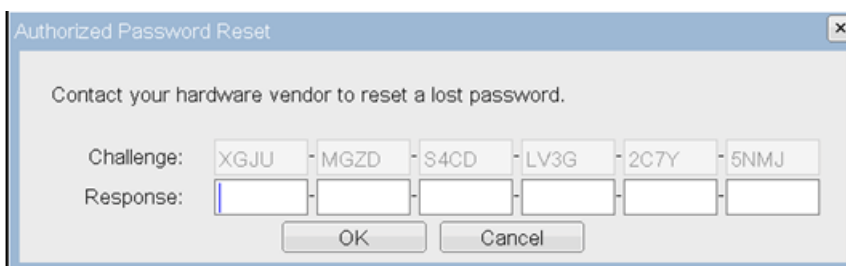

- Details on how to use PCoIP are subject to change. To view the latest information, visit the Teradici website. (<http://www.teradici.com>)

What is Natural Color?

One of the problems with using a PC is that the colors you see on the screen are different from the colors of printed pictures or source images input through a scanner or digital camera. Natural Color is a color management system developed by Samsung Electronics to resolve this problem. This software works with Samsung products only and enables you to adjust the displayed colors on the screen to match the colors of the printed pictures. For more information, refer to the online help of the software (F1).

The Natural Color is provided online. You can download it from the website below and install;



http://www.samsung.com/us/consumer/learningresources/monitor/naturalcolorexpert/pop_download.html

What is MultiScreen ?



MultiScreen enables users to use the monitor by partitioning multiple sections.

Installing the Software

1. Insert the installation CD into the CD-ROM drive.
2. Select the MultiScreen setup program.
 -  If the pop-up screen for the software installation does not appear on the main screen, find and double-click the MultiScreen setup file on the CD-ROM.
3. When the Installation Wizard appears, click [Next].
4. Complete the remaining software installation steps according to the instructions displayed on the screen.
 -  The software may not work properly if you do not restart the computer after the installation.
The MultiScreen icon may not appear depending on the computer system and the product specifications.
If the shortcut icon does not appear, press the F5 key.

Restrictions and Problems with the Installation (MultiScreen)

The MultiScreen installation may be affected by the graphics card, motherboard and the networking environment.

Operating System

OS

- Windows 2000
- Windows XP Home Edition
- Windows XP Professional
- Windows Vista 32Bit
- Windows 7 32Bit

 For MultiScreen, the operating systems Windows 2000 or later is recommended.

Hardware

- At least 32MB of memory
- At least 60MB of free space on the hard disk drive

Removing the Software

Click [Start], select [Settings]/[Control Panel], and then double-click [Add or Remove Programs].

Select MultiScreen from the program list and click the [Add/Delete] button.

5 Troubleshooting

5-1 Monitor Self-Diagnosis

- You can check if the product is working properly using the Self-Diagnosis function.
- If a blank screen is displayed and the Power LED blinks even if the product and the PC are properly connected, perform the self-diagnosis function according to the procedures below.

1. Turn the product and the PC off.
2. Separate the signal cable from the product .
3. Turn the product on.
4. If the product is working properly, the <Check Signal Cable> message appears.

In this case, if a blank screen is displayed again, make sure that there is no problem with the PC and the connection. The product is working properly.

5-2 Before Requesting Service

-  Please check the following before requesting After-Sales service. If the problem continues, please contact your nearest Samsung Electronics Service Center.

A BLANK SCREEN APPEARS / I CANNOT TURN THE PRODUCT ON.	
Is the power cord connected properly?	Check the connection status of the power cord.
Is the <Check Signal Cable> message displayed on the screen?	Check the cable connecting the PC and the product. If the message appears on the screen even if the cable is properly connected, recheck the input signal by pressing the [☐]/SOURCE] button of the product.
Is the <Not Optimum Mode> message displayed on the screen?	This occurs when the signal from the graphics card exceeds the maximum resolution or the maximum frequency of the product. In this case, set up the appropriate resolution and the frequency for the product.
Is a blank screen displayed and does the power LED blink at a 1 second interval?	This occurs when the power saving function is running. If you click the mouse or press any key, the screen will be turned on.
THE IMAGE IS TOO LIGHT OR TOO DARK.	
Adjust the <Brightness> and <Contrast>. If <MagicBright> is set to <Dynamic Contrast>, the display brightness can differ according to the input signal.	
THE BUTTONS ON THE MONITOR ARE NOT FUNCTIONING.	
Is the key lock mode enabled?	Disable the key lock mode if it is enabled.
THE COLOR IS WEIRD / THE PICTURE IS DISPLAYED IN BLACK AND WHITE.	
Is the entire screen displayed in the same color as if viewing the screen through a cellophane paper?	Check the cable connection to the computer. Reinsert the graphics card into the computer completely. Check if the <Color Effect> is set to <Off>.
Is the graphics card configured correctly?	Set up the graphics card referring to the user manual.
THE DISPLAY AREA SUDDENLY MOVES TO AN EDGE OR TO THE CENTER.	
Did you change the graphics card or the driver?	Please press the [AUTO] button to run the auto adjustment function.
Did you change the resolution and frequency appropriate to the product?	Set the resolution and the frequency to the appropriate values in the graphics card refer to the (Standard Signal Mode Table)
Is the graphics card configured correctly?	Set up the graphics card referring to the user manual.
THE PICTURES ARE OUT-OF-FOCUS.	
Did you change the resolution and the frequency appropriate to the product?	Set the resolution and the frequency to the appropriate values in the graphics card refer to the (Standard Signal Mode Table)

THE COLOR IS DISPLAYED IN 16 BIT (16 COLORS). THE COLOR HAS BEEN CHANGED AFTER CHANGING THE GRAPHICS CARD.

Did you install the device driver for the product?

Windows XP : Set the color again by selecting Control Panel → Appearance and Themes → Display → Settings.
 Windows ME/2000 : Set the color again by selecting Control Panel → Display → Settings.
 Windows Vista : Change the color settings by selecting Control Panel → Appearance and Personalization → Personalization → Display settings.
 Windows 7 : Change the color settings by selecting Control Panel → Appearance and Personalization → Display → Adjust resolution → Advanced settings → Monitor.
 (For more information, refer to the Windows user manual for the computer.)

Is the graphics card configured correctly?

Configure the color again in accordance with the new graphics card driver.

WHEN I CONNECT THE MONITOR, THE 'UNKNOWN MONITOR, PLUG&PLAY (VESA DDC) MONITOR FOUND' MESSAGE IS DISPLAYED.

Did you install the device driver for the product?

Install the device driver referring to the descriptions about the driver installation.

Check if all the Plug&Play (VESA DDC) functions are supported referring to the User Manual of the graphics card.

Install the device driver referring to the descriptions about the driver installation.

WHEN I LOOK AT THE EXTERIOR EDGES OF THE PRODUCT, SMALL ALIEN SUBSTANCES APPEAR ON IT.

Since this product is designed so that the color has a soft appearance by coating it with a transparent material over the black edges, such things may be seen. This is not a defect of the product.

A "BEEP, BEEP" SOUND IS HEARD WHEN BOOTING THE COMPUTER.

If the beep sound is generated 3 or more times when booting up the computer, please request service for the computer.

Problems Related to Audio.

No sound

Ensure that the audio cable is firmly connected to both the audio-in port on your monitor and the audio-out port on your sound card.
 Check the volume level.

Sound level is too low.

Check the volume level.
 If the volume is still too low after turning the control to its maximum, check the volume control on the computer sound card or software program.

FAQ!	PLEASE TRY THE FOLLOWING!
How can I change the frequency of the video signal?	<p>You have to change the frequency of the graphics card.</p> <p>Windows XP : Change the frequency by selecting Control Panel → Appearance and Themes → Display → Settings → Advanced → Monitor, and then change the refresh rate under Monitor Settings.</p> <p>Windows ME/2000 : Change the frequency by selecting Control Panel → Display → Settings → Advanced → Monitor, and then change the refresh rate under Monitor Settings.</p> <p>Windows Vista : Change the frequency by selecting Control Panel → Appearance and Personalization → Personalization → Display settings → Advanced settings → Monitor, and then change the refresh rate under Monitor Settings.</p> <p>Windows 7 : Change the frequency by selecting Control Panel → Appearance and Personalization → Display → Adjust resolution → Advanced settings → Monitor, and then change the refresh rate under Monitor Settings.</p> <p>(For more information, refer to the User Manual of the computer or the graphics card.)</p>
How can I change the resolution?	<p>Windows XP : Change the resolution by selecting Control Panel → Appearance and Themes → Display → Settings.</p> <p>Windows ME/2000 : Change the resolution by selecting Control Panel → Display → Settings.</p> <p>Windows Vista : Change the resolution by selecting Control Panel → Appearance and Personalization → Personalization → Display settings.</p> <p>Windows 7 : Change the resolution by selecting Control Panel → Appearance and Personalization → Display → Adjust resolution.</p> <p>(For more information, refer to the User Manual of the computer or the graphics card.)</p>
How can I use the power saving function?	<p>Windows XP : Configure it by selecting Control Panel → Appearance and Themes → Display → Screen Saver Setting or configure it in the BIOS Setup of the computer.</p> <p>Windows ME/2000 : Configure it by selecting Control Panel → Display → Screen Saver Setting or Configure it in the BIOS Setup of the computer.</p> <p>Windows Vista : Change settings by selecting Control Panel → Appearance and Personalization → Personalization → Screen Saver. You can also use the BIOS SETUP menu on the PC.</p> <p>Windows 7 : Change settings by selecting Control Panel → Appearance and Personalization → Personalization → Screen Saver. You can also use the BIOS SETUP menu on the PC.</p> <p>(For more information, refer to the Windows user manual for the computer.)</p>

6 More Information

6-1 Specifications

MODEL NAME		NC220
Panel	Size	22 inches (55cm)
	Display area	473.76 mm (H) × 296.1 mm (V) 18.7 inches (H) × 11.7 inches (V)
Synchroniza- tion	Horizontal	31~70kHz
	Vertical	56~75Hz
Display Color		16.7M
Resolution	Optimum resolution	1680 X 1050 @ 60Hz
	Maximum resolution	1680 X 1050 @ 60Hz
Input Signal, Terminated		RGB Analog 0.7 Vp-p ± 5 % Separate H/V sync, Composite TTL Level (V high ≥ 2.0 V, V low ≤ 0.8 V)
Maximum Pixel Clock		146.250MHz (Analog / Digital)
Power Supply		This product supports 100 – 240 V. Since the standard voltage may differ from country to country, please check the label on the back of the product.
Signal connectors		RGB IN(D-Sub) port
Server connector		LAN port
USB		USB 2.0 X 4(Down stream)
Dimensions (WxHxD) / Weight		508.0 X 515.0 X 215.6 mm (20.0 X 20.3 X 8.5 inches) (With Stand) / 5.5 kg (12.12 lbs) 508.0 X 344.3 X 56.6 mm (20.0 X 13.6 X 2.2 inches) (Without Stand) / 3.8 kg (8.38 lbs)
VESA Mounting Interface		100 mm X 100 mm / 3.9 inches X 3.9 inches 100 mm X 200 mm / 3.9 inches X 7.9 inches
Environmen- tal consider- ations	Operating	Temperature : 50 ° F ~ 104 ° F (10 ° C ~ 40 ° C) Humidity :10 % ~ 80 %, non-condensing
	Storage	Temperature : -4 ° F ~ 113 ° F (-20 ° C ~ 45 ° C) Humidity : 5 % ~ 95 %, non-condensing
Tilt		2° (±1°) ~ 25° (±1°)

 Design and specifications are subject to change without prior notice.

 Class B (Information Communication equipment for residential use)

This device is registered for EMC requirements for home use (Class B). It can be used in all areas.

(Class B equipment emits less electromagnetic waves than Class A equipment.)

(USA ONLY)

Dispose unwanted electronics through an approved recycler.

To find the nearest recycling location, go to our website,

www.samsung.com/recyclingdirect, or call (877) 278 - 0799

6-2 Power Saving Function

This product provides a power saving function that automatically turns the screen off when the product is not used for a predetermined period of time to reduce power consumption. If the product enters power saving mode, the power LED turns to a different color to indicate that the product is in power saving mode.

When the product is in power saving mode, the power is not turned off and you can turn the screen on again by pressing any key or clicking the mouse. However, the power saving function only works when the product is connected to a computer that provides the power saving function.

STATE	NORMAL OPERATION	POWER OFF (POWER BUTTON OFF)	POWER OFF (MECHANICAL SWITCH OFF)
Power Indicator	On	Off	Off
Power Consumption (Typical)	38 W	less than 0.8 W	0 W

- The actual power consumption may be different from the indicated power consumption above if the system conditions or settings are changed.
- To stop any power consumption, turn off the switch or disconnect the power cable on the back. Be sure to disconnect the power if you intend to stay away from home for many hours.

6-3 Contact SAMSUNG WORLDWIDE

 If you have any questions or comments relating to Samsung products, please contact the SAMSUNG customer care center.

NORTH AMERICA		
U.S.A	1-800-SAMSUNG (726-7864)	http://www.samsung.com
CANADA	1-800-SAMSUNG (726-7864)	http://www.samsung.com/ca http://www.samsung.com/ca_fr (French)
MEXICO	01-800-SAMSUNG (726-7864)	http://www.samsung.com
LATIN AMERICA		
ARGENTINA	0800-333-3733	http://www.samsung.com
BRAZIL	0800-124-421 4004-0000	http://www.samsung.com
BOLIVIA	800-10-7260	http://www.samsung.com
CHILE	800-SAMSUNG (726-7864) From mobile 02-482 82 00	http://www.samsung.com
COLOMBIA	01-8000112112	http://www.samsung.com
COSTA RICA	0-800-507-7267	http://www.samsung.com
DOMINICA	1-800-751-2676	http://www.samsung.com
ECUADOR	1-800-10-7267	http://www.samsung.com
EL SALVADOR	800-6225	http://www.samsung.com
GUATEMALA	1-800-299-0013	http://www.samsung.com
HONDURAS	800-27919267	http://www.samsung.com
JAMAICA	1-800-234-7267	http://www.samsung.com
NICARAGUA	00-1800-5077267	http://www.samsung.com
PANAMA	800-7267	http://www.samsung.com
PERU	0-800-777-08	http://www.samsung.com
PUERTO RICO	1-800-682-3180	http://www.samsung.com
TRINIDAD & TOBAGO	1-800-SAMSUNG (726-7864)	http://www.samsung.com
VENEZUELA	0-800-100-5303	http://www.samsung.com
EUROPE		
ALBANIA	42 27 5755	http://www.samsung.com
AUSTRIA	0810 - SAMSUNG (7267864, € 0.07/min)	http://www.samsung.com
BELGIUM	02-201-24-18	http://www.samsung.com/be (Dutch) http://www.samsung.com/be_fr (French)
BOSNIA	05 133 1999	http://www.samsung.com
BULGARIA	07001 33 11	http://www.samsung.com
CROATIA	062 SAMSUNG (062 726 7864)	http://www.samsung.com

EUROPE

CZECH	800 - SAMSUNG (800-726786)	http://www.samsung.com
	Samsung Electronics Czech and Slovak, s.r.o., Oasis Florenc, Sokolovská 394/17, 180 00, Praha 8	
DENMARK	70 70 19 70	http://www.samsung.com
FINLAND	030 - 6227 515	http://www.samsung.com
FRANCE	01 48 63 00 00	http://www.samsung.com
GERMANY	01805 - SAMSUNG (726-7864, € 0,14/Min)	http://www.samsung.com
CYPRUS	From landline : 8009 4000	http://www.samsung.com
GREECE	From landline : 80111- SAMSUNG (7267864) From landline & mobile : (+30) 210 6897691	http://www.samsung.com
HUNGARY	06-80-SAMSUNG (726-7864)	http://www.samsung.com
ITALIA	800-SAMSUNG (726-7864)	http://www.samsung.com
KOSOVO	+381 0113216899	http://www.samsung.com
LUXEMBURG	261 03 710	http://www.samsung.com
MACEDONIA	023 207 777	http://www.samsung.com
MONTENEGRO	020 405 888	http://www.samsung.com
NETHERLANDS	0900 - SAMSUNG (0900-7267864) (€ 0,10/Min)	http://www.samsung.com
NORWAY	815-56 480	http://www.samsung.com
POLAND	0 801-1SAMSUNG (172-678) +48 22 607-93-33	http://www.samsung.com
PORTUGAL	808 20 - SAMSUNG (808 20 7267)	http://www.samsung.com
RUMANIA	From landline : 08010- SAMSUNG (7267864) From landline & mobile : (+40) 21 206 01 10	http://www.samsung.com
SERBIA	0700 Samsung (0700 726 7864)	http://www.samsung.com
SLOVAKIA	0800 - SAMSUNG(0800-726 786)	http://www.samsung.com
SPAIN	902 - 1 - SAMSUNG (902 172 678)	http://www.samsung.com
SWEDEN	0771 726 7864 (SAMSUNG)	http://www.samsung.com
SWITZERLAND	0848-SAMSUNG (7267864, CHF 0.08/min)	http://www.samsung.com/ch http://www.samsung.com/ch_fr (French)
U.K	0330 SAMSUNG (7267864)	http://www.samsung.com
EIRE	0818 717100	http://www.samsung.com
LITHUANIA	8-800-77777	http://www.samsung.com
LATVIA	8000-7267	http://www.samsung.com
ESTONIA	800-7267	http://www.samsung.com
TURKEY	444 77 11	http://www.samsung.com

CIS		
RUSSIA	8-800-555-55-55	http://www.samsung.com
GEORGIA	8-800-555-555	http://www.samsung.com
ARMENIA	0-800-05-555	http://www.samsung.com
AZERBAIJAN	088-55-55-555	http://www.samsung.com
KAZAKHSTAN	8-10-800-500-55-500 (GSM: 7799)	http://www.samsung.com
UZBEKISTAN	8-10-800-500-55-500	http://www.samsung.com
KYRGYZSTAN	00-800-500-55-500	http://www.samsung.com
TADJIKISTAN	8-10-800-500-55-500	http://www.samsung.com
MONGOLIA		http://www.samsung.com
UKRAINE	0-800-502-000	http://www.samsung.com/ua http://www.samsung.com/ua_ru
BELARUS	810-800-500-55-500	http://www.samsung.com
MOLDOVA	00-800-500-55-500	http://www.samsung.com
ASIA PACIFIC		
AUSTRALIA	1300 362 603	http://www.samsung.com
NEW ZEALAND	0800 SAMSUNG (0800 726 786)	http://www.samsung.com
CHINA	400-810-5858	http://www.samsung.com
HONG KONG	(852) 3698 - 4698	http://www.samsung.com/hk http://www.samsung.com/hk_en/
INDIA	1800 1100 11 3030 8282 1800 3000 8282 1800 266 8282	http://www.samsung.com
INDONESIA	0800-112-8888 021-5699-7777	http://www.samsung.com
JAPAN	0120-327-527	http://www.samsung.com
MALAYSIA	1800-88-9999	http://www.samsung.com
PHILIPPINES	1-800-10-SAMSUNG (726-7864) for PLDT 1-800-3-SAMSUNG(726-7864) for Digitel 1-800-8-SAMSUNG(726-7864) for Globe 02-5805777	http://www.samsung.com
SINGAPORE	1800-SAMSUNG (726-7864)	http://www.samsung.com
THAILAND	1800-29-3232 02-689-3232	http://www.samsung.com
TAIWAN	0800-329-999 0266-026-066	http://www.samsung.com
VIETNAM	1 800 588 889	http://www.samsung.com

MIDDLE EAST		
IRAN	021-8255	http://www.samsung.com
OMAN	800-SAMSUNG (726-7864)	http://www.samsung.com
KUWAIT	183-2255	http://www.samsung.com
BAHRAIN	8000-4726	http://www.samsung.com
EGYPT	08000-726786	http://www.samsung.com
JORDAN	800-22273	http://www.samsung.com
MOROCCO	080 100 2255	http://www.samsung.com
SAUDI ARABIA	9200-21230	http://www.samsung.com
U.A.E	800-SAMSUNG (726-7864)	http://www.samsung.com
AFRICA		
CAMEROON	7095- 0077	http://www.samsung.com
COTE D' IVOIRE	8000 0077	http://www.samsung.com
GHANA	0800-10077 0302-200077	http://www.samsung.com
KENYA	0800 724 000	http://www.samsung.com
NIGERIA	0800-726-7864	http://www.samsung.com
SENEGAL	800-00-0077	http://www.samsung.com
SOUTH AFRICA	0860-SAMSUNG (726-7864)	http://www.samsung.com
TANZANIA	0685 88 99 00	http://www.samsung.com
UGANDA	0800 300 300	http://www.samsung.com

6-4 Correct Disposal of This Product (Waste Electrical & Electronic Equipment)



(Applicable in the European Union and other European countries with separate collection systems)

This marking on the product, accessories or literature indicates that the product and its electronic accessories (e.g. charger, headset, USB cable) should not be disposed of with other household waste at the end of their working life. To prevent possible harm to the environment or human health from uncontrolled waste disposal, please separate these items from other types of waste and recycle them responsibly to promote the sustainable reuse of material resources.

Household users should contact either the retailer where they purchased this product, or their local government office, for details of where and how they can take these items for environmentally safe recycling.

Business users should contact their supplier and check the terms and conditions of the purchase contract. This product and its electronic accessories should not be mixed with other commercial wastes for disposal.