



TECHNICAL GUIDE

SPLIT-SYSTEM HEAT PUMPS

14.5 SEER – R-410A

MODELS:
YHJF18 THRU 60
(1.5 THRU 5 NOMINAL TONS, 1 PHASE)



ISO 9001
Certified Quality
Management System



Due to continuous product improvement, specifications are subject to change without notice.

Visit us on the web at www.york.com

Additional rating information can be found at
www.ahridirectory.org

DESCRIPTION

The heat pump condensing unit is the outdoor part of a versatile system of heating and air conditioning. It is designed to be custom-matched with one of UPG's complete line of evaporator sections, with each serving a specific function. Matching Air Handlers are available for upflow, downflow, or horizontal applications to provide a complete system. Electric Heaters are available, if required. Add-on coils are available for use with upflow, downflow, or horizontal furnaces and air handlers. Many matches meet Federal Tax Rebate program.

WARRANTY

Single Phase Units:

5-year limited parts warranty.

10-year limited compressor warranty.

FEATURES

- **QUALITY CONDENSER COILS** - The coil is constructed of copper tubing and enhanced aluminum fins for increased efficiency and corrosion protection.
- **PROTECTED COMPRESSOR** - The complete scroll compressor line is internally protected against high pressure, temperature, and externally by a factory installed high pressure switch. This is accomplished by the simultaneous operation of high pressure relief valve and a temperature sensor which protects the compressor if undesirable operating conditions occur. A liquid line filter-drier further protects the compressor.
- **DURABLE FINISH** - The cabinet is made of pre-painted steel. The pre-treated galvanized steel provides a better paint to steel bond, which resists corrosion and rust creep. Special primer formulas and matted-textured finish insure less fading when exposed to sunlight.
- **LOWER INSTALLED COST** - Installation time and costs are reduced by easy power and control wiring connections. Available in sweat connect models only. The unit contains enough refrigerant for matching indoor coils and 15 feet of interconnecting piping. The small base dimension means less space is required on the ground or roof.
- **TOP DISCHARGE** - The warm air from the top mounted fan is blown up away from the structure and any landscaping. This allows compact location on multi-unit applications.
- **SWEPT FAN BLADE SOUND JACKET** - The upward air flow carries the normal operating noise away from the living area. The rigid top panel effectively isolates any motor sound. Isolator mounted compressor and the rippled fins of the condenser coil muffle the normal fan motor and compressor operating sounds. The swept wing fan blade and compressor sound jacket further reduce noise levels.
- **LOW MAINTENANCE** - Long life permanently lubricated motor-bearings need no annual servicing.
- **EASY SERVICE ACCESS** - Fully exposed refrigerant connections, and a single panel covering the electrical controls make for easy servicing of the unit.
- **SECURED SERVICE VALVES** - Secured re-usable service valves are provided on both the liquid and vapor sweat connections for ease of evacuating and charging.
- **U.L. and C.U.L. listed** - approved for outdoor application.
- **Agency Listed** - U.L. and C.U.L. listed - approved for outdoor application. The unit is certified in accordance with the Unitary Small Equipment certification program, which is based on ARI Standard 210/240.

Physical and Electrical Data

MODEL	YHJF18 S41S1	YHJF24 S41S1	YHJF30 S41S1	YHJF36 S41S1	YHJF42 S41S1	YHJF48 S41S1	YHJF60 S41S1
Unit Supply Voltage	208-230V, 1 ϕ , 60Hz						
Normal Voltage Range ¹	187 to 252						
Minimum Circuit Ampacity	11.9	17.6	17.3	23.7	26.1	28.8	35.3
Max. Overcurrent Device Amps ²	20	30	30	40	45	50	60
Min. Overcurrent Device Amps ³	15	20	20	25	30	30	40
Compressor Type	Scroll	Scroll	Scroll	Scroll	Scroll	Scroll	Scroll
Compressor Amps	Rated Load	9.0	13.4	12.8	17.9	19.8	35.3
	Locked Rotor	48.0	58.3	64.0	96.7	115.0	118.0
Crankcase Heater	No	No	No	No	No	No	No
Fan Motor Amps	Rated Load	0.7	0.8	1.3	1.3	1.3	1.3
Fan Diameter Inches	24	22	24	24	24	24	24
Fan Motor	Rated HP	1/10	1/8	1/4	1/4	1/4	1/4
	Nominal RPM	825	1075	850	850	850	850
	Nominal CFM	2000	2000	3900	3900	3900	3800
Coil	Face Area Sq. Ft.	15.72	19.17	23.58	23.58	23.58	23.58
	Rows Deep	1	1	1	1	1	2
	Fin / Inches	22	22	22	22	22	18
Liquid Line Set OD (Field Installed)	3/8	3/8	3/8	3/8	3/8	3/8	3/8
Vapor Line Set OD (Field Installed)	3/4	3/4	3/4	3/4	7/8	7/8	1-1/8
Unit Charge (Lbs. - Oz.) ⁴	6 – 15	7 – 14	9 – 14	10 – 9	10 – 9	14 – 2	14 – 2
Charge Per Foot, Oz.	0.62	0.62	0.62	0.62	0.67	0.67	0.75
Operating Weight Lbs.	145	145	176	193	198	248	290

1. Rated in accordance with ARI Standard 110, utilization range "A".
2. Dual element fuses or HACR circuit breaker. Maximum allowable overcurrent protection.
3. Dual element fuses or HACR circuit breaker. Minimum recommended overcurrent protection.
4. The Unit Charge is correct for the outdoor unit, matched indoor coil and 15 feet of refrigerant tubing. For tubing lengths other than 15 feet, add or subtract the amount of refrigerant, using the difference in length multiplied by the per foot value.

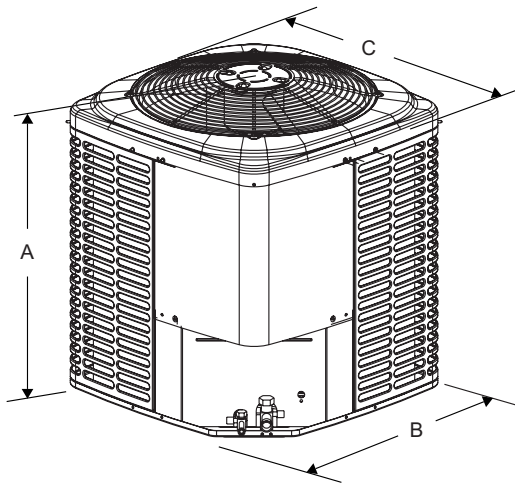

All dimensions are in inches. They are subject to change without notice. Certified dimensions will be provided upon request.

Unit Model	Dimensions (Inches)			Refrigerant Connection Service Valve Size	
	A ¹	B	C	Liquid	Vapor
18	28	34	34	3/8"	3/4"
24	40	29	29		
30	40	34	34		
36	40	34	34		
42	40	34	34		
48	40	34	34	7/8"	
60	40	34	34		

1. Including Fan Guard.

System Charge for Various Matched Systems							
Outdoor Unit	YHJF18 S41S1	YHJF24 S41S1	YHJF30 S41S1	YHJF36 S41S1	YHJF42 S41S1	YHJF48 S41S1	YHJF60 S41S1
Required Orifice or TXV ^{1,2}	.051/1TVM4F1	.059/1TVM4G1	.063/1TVM4G1	.071/1TVM4H1	.075/1TVM4J1	1TVM4J1	1TVM4K1
Factory Charge, lbs-oz	6 - 15	7 - 14	9 - 14	10 - 9	10 - 9	14 - 2	14 - 2
Indoor Coil ^{3,4}	Additional Charge, Oz						
FC/MC/PC/UC32	.051 + 0	.059 + 0	–	–	–	–	–
FC/MC/PC/UC35	.051 + 0	.059 + 0	–	–	–	–	–
FC/MC/PC/UC37	.051 + 13	.059 + 12	.063 + 0	.071 + 0	–	–	–
FC/MC/PC/UC43	.051 + 13	.059 + 12	.063 + 0	.071 + 0	–	–	–
FC/PC62D3X	–	–	–	–	.075 + 0	TXV + 0	TXV + 0
AHX30	.051 + 0	.059 + 0	–	–	–	–	–
AHX36	.051 + 13	.059 + 12	.063 + 0	.071 + 0	–	–	–
AHX60	–	–	–	–	.075 + 0	TXV + 0	TXV + 0
AV36	.051 + 13	.059 + 12	.063 + 0	.071 + 0	–	–	–
F6FP030H06	.051 + 0	.059 + 0	–	–	–	–	–
F6FP036H06	.051 + 0	.059 + 0	–	–	–	–	–
F6FP042H06	–	–	.063 + 3	.063 + 3	–	–	–
F6FP060H06	–	–	–	–	.075 + 0	TXV + 0	TXV + 0

FOOTNOTES:

1. For applications requiring a TXV use 1TVM900 series kit.
2. Approved orifice shipped with outdoor unit.
3. Systems matched with furnace or air handlers not equipped with blower-off delays may require blower Time Delay Kit 2FD06700224.
4. PC coils cannot be used in downflow or horizontal applications. FC coils cannot be used in horizontal applications.

PROCEDURES:

1. Unit factory charge listed on the unit nameplate includes refrigerant for the condenser, the smallest evaporator and 15 feet of interconnecting line tubing.
2. Verify the TXV and additional charge required for specific evaporator coil in the system using the above table.
3. Additional charge for the amount of interconnecting line tubing greater than 15 feet at the rate specified in Physical and Electrical Data Table.
4. For orifice or TXV matches requiring additional charge, the refrigerant needs to be weighed in for specific coil match and lineset length.
5. Permanently mark the unit nameplate with the total system charge. Total System Charge = Base Charge (as shipped) + adder for evaporator + adder for line set.

COOLING CAPACITY - With Air Handler Coils

UNIT MODEL	AIR HANDLER		COIL MODEL ¹	STAGE	COOLING				
	MODEL	W			RATED CFM	NET MBH		SEER	EER
						TOTAL	SENS.		
14.5 SEER HP WITH MV - VARIABLE SPEED									
YHJF18S41S1	MV12B	17	FC/MC35B	—	600	18.0	13.0	15.00	12.50
	MV12B	17	FC/MC43B	—	600	18.0	13.3	15.00	12.50
YHJF24S41S1	MV12B	17	FC/MC35B	—	800	22.8	17.2	15.00	12.50
	MV12B	17	FC/MC43B	—	800	23.4	18.0	15.00	12.50
YHJF30S41S1	MV12B	17	FC/MC43B	—	1000	29.0	21.6	15.00	12.50
	MV16C	21	FC/MC43C	—	1000	29.0	21.6	15.00	12.50
YHJF36S41S1	MV12B	17	FC/MC43B	—	1225	35.4	26.6	14.35	12.00
	MV16C	21	FC/MC43C	—	1200	35.2	26.4	14.50	12.00
YHJF42S41S1	MV20D	24	FC/MC62D	—	1400	40.0	30.8	14.50	12.00
YHJF48S41S1	MV20D	24	FC/MC62D	—	1630	48.0	36.2	15.00	12.50
YHJF60S41S1	MV20D	24	FC/MC62D	1	1160	48.0	31.0	14.50	21.55
				2	1855	57.0	40.5		12.00
14.5 SEER HP WITH AV / SV / F*FV - VARIABLE SPEED									
YHJF18S41S1	AV*36	21	—	—	630	18.0	13.3	15.00	12.50
YHJF24S41S1	AV*36	21	—	—	725	22.8	16.8	15.00	12.50
YHJF30S41S1	AV*36	21	—	—	960	29.2	21.8	15.00	12.50
YHJF36S41S1	AV*36	21	—	—	1190	35.4	26.4	14.50	12.00
14.5 SEER HP WITH AHP / SHP / AHX / F*FP									
YHJF18S41S1	AHX30	17	—	—	640	18.0	13.3	15.00	12.50
YHJF24S41S1	AHX30	17	—	—	800	22.8	17.1	15.00	12.50
	F6FP030	17	—	—	850	22.8	17.3	14.50	12.00
	F6FP036	21	—	—	855	22.8	17.4	15.00	12.50
	AHX36	21	—	—	820	23.0	17.4	15.00	12.50
YHJF30S41S1	AHX36	21	—	—	1030	29.4	22.2	15.00	12.50
	F6FP042	21	—	—	1065	29.4	22.2	15.00	12.50
YHJF36S41S1	AHX36	21	—	—	1210	35.4	26.6	14.50	12.00
	AHX42	21	—	—	1190	35.8	26.8	15.00	12.50
	F6FP042	24	—	—	1290	36.0	27.6	15.00	12.50
YHJF42S41S1	AHX60	24	—	—	1355	40.0	30.2	14.50	12.00
	F6FP060	24	—	—	1475	40.5	31.4	14.50	12.00
YHJF48S41S1	AHX60	24	—	—	1570	48.0	35.6	15.00	12.50
	F6FP060	24	—	—	1570	48.0	35.6	15.00	12.50
YHJF60S41S1	AHX60	24	—	1	1160	47.5	30.5	14.50	21.20
			—	2	1855	57.0	40.5		12.00

Rated in accordance with DOE test procedures (Federal Register 12-27-79 and 3-18-88) and ARI Standards 210.

Cooling MBH based on 80°F entering air temperature, 50% RH, and rated air flow.

EER (Energy Efficiency Ratio) is the total cooling output in BTU's at 95°F outdoor ambient divided by the total electric power in watt-hours at those conditions.

SEER (Seasonal Energy Efficiency Ratio) is the total cooling output in BTU's during a normal annual usage period for cooling divided by the total electric power input in watt-hours during the same period.

1. MC coils available with a factory installed horizontal drain pan. See price pages for specific model number.

— = Not applicable.

COOLING CAPACITY - With High Efficiency Motor Furnaces

UNIT MODEL	FURNACE MODEL	COIL MODEL ¹	W	STAGE	COOLING				
					RATED CFM	Net MBH		SEER	EER
						TOTAL	SENS.		
14.5 SEER HP WITH VARIABLE SPEED FURNACES²									
YHJF18S41S1	T*(8,L)X*A12	FC/MC/PC32A	14	-	590	18.0	13.0	15.00	12.50
	Y*(8,L)(C,V)*A12	FC/MC/PC32A	14	-	590	18.0	13.0	15.00	12.50
	Y*(8,L)(C,V)*B12	FC/MC/PC35B	17	-	650	18.0	13.4	15.00	12.50
	Y*(8,L)(C,V)*C16	FC/MC/PC35C	21	-	600	18.0	13.0	15.00	12.50
	Y*9(C,V)*B12	FC/MC/PC35B	17	-	570	18.0	13.0	15.00	12.50
	Y*9(C,V)*C16	FC/MC/PC35C	21	-	645	18.0	13.4	15.00	12.50
	Y*(8,L)(C,V)*A12	FC/MC/PC37A	14	-	625	18.0	13.3	15.00	12.50
	Y*(8,L)(C,V)*B12	FC/MC/PC43B	17	-	560	18.0	12.8	15.00	12.50
YHJF24S41S1	T*(8,L)X*A12	FC/MC/PC32A	14	-	800	23.0	17.3	15.00	12.50
	T*(8,L)X*B12	FC/MC/PC35B	17	-	850	23.0	17.8	15.00	12.50
	T*(8,L)X*C16	FC/MC/PC35C	21	-	865	23.2	18.0	15.00	12.50
	T*(8,L)X*C20	FC/MC/PC35C	21	-	865	23.2	18.1	15.00	12.50
	T*9X*B12	FC/MC/PC35B	17	-	785	23.0	17.3	15.00	12.50
	T*9X*C16	FC/MC/PC35C	21	-	765	23.0	17.3	15.00	12.50
	T*9X*C20	FC/MC/PC35C	21	-	825	23.0	17.2	15.00	12.50
	T*(8,L)X*A12	FC/MC/PC37A	14	-	840	23.4	18.0	15.00	12.50
	T*(8,L)X*B12	FC/MC/PC43B	17	-	865	23.4	18.1	15.00	12.50
	T*(8,L)X*C16	FC/MC/PC43C	21	-	855	23.4	18.1	15.00	12.50
	T*9X*B12	FC/MC/PC43B	17	-	800	23.4	18.0	15.00	12.50
	T*9X*C16	FC/MC/PC43C	21	-	785	23.2	17.5	15.00	12.50
	T*9X*C20	FC/MC/PC43C	21	-	790	23.2	17.4	15.00	12.50
	Y*(8,L)(C,V)*A12	FC/MC/PC32A	14	-	775	22.8	17.1	14.50	12.00
	Y*(8,L)(C,V)*B12	FC/MC/PC35B	17	-	760	22.6	16.7	15.00	12.50
	Y*(8,L)(C,V)*C16	FC/MC/PC35C	21	-	855	23.0	17.7	15.00	12.50
	Y*(8,L)(C,V)*C20	FC/MC/PC35C	21	-	740	22.6	16.6	15.00	12.50
	Y*9(C,V)*B12	FC/MC/PC35B	17	-	815	22.8	17.1	14.50	12.00
	Y*9(C,V)*C16	FC/MC/PC35C	21	-	865	23.2	18.2	15.00	12.50
	Y*9(C,V)*C20	FC/MC/PC35C	21	-	755	22.6	16.7	15.00	12.50
	Y*(8,L)(C,V)*A12	FC/MC/PC37A	14	-	805	23.2	17.9	15.00	12.50
	Y*(8,L)(C,V)*B12	FC/MC/PC43B	17	-	760	22.8	17.0	15.00	12.50
	Y*(8,L)(C,V)*C16	FC/MC/PC43C	21	-	875	23.4	18.5	15.00	12.50
	Y*(8,L)(C,V)*C20	FC/MC/PC43C	21	-	760	23.0	17.1	15.00	12.50
Y*9(C,V)*B12	FC/MC/PC43B	17	-	800	23.2	17.9	15.00	12.50	
Y*9(C,V)*C16	FC/MC/PC43C	21	-	810	23.4	18.0	15.00	12.50	
Y*9(C,V)*C20	FC/MC/PC43C	21	-	875	23.4	18.4	15.00	12.50	
YHJF30S41S1	T*(8,L)X*A12	FC/MC/PC37A	14	-	1095	29.4	23.0	15.00	12.50
	T*(8,L)X*B12	FC/MC/PC43B	17	-	1105	29.6	23.2	15.00	12.50
	T*(8,L)X*C16	FC/MC/PC43C	21	-	955	29.2	21.6	15.00	12.50
	T*9X*B12	FC/MC/PC43B	17	-	1095	29.4	23.0	15.00	12.50
	T*9X*C16	FC/MC/PC43C	21	-	1055	29.4	22.6	15.00	12.50
	Y*(8,L)(C,V)*A12	FC/MC/PC37A	14	-	980	28.6	21.4	14.50	12.00
	Y*(8,L)(C,V)*B12	FC/MC/PC43B	17	-	990	28.8	21.4	15.00	12.50
	Y*(8,L)(C,V)*C16	FC/MC/PC43C	21	-	990	29.0	21.6	15.00	12.50
	Y*(8,L)(C,V)*C20	FC/MC/PC43C	21	-	1000	29.0	21.6	15.00	12.50
	Y*9(C,V)*B12	FC/MC/PC43B	17	-	1035	29.0	22.0	14.50	12.00
	Y*9(C,V)*C16	FC/MC/PC43C	21	-	1030	29.2	22.2	15.00	12.50
	Y*9(C,V)*C20	FC/MC/PC43C	21	-	995	29.0	21.6	15.00	12.50

For Notes See Page 6.

COOLING CAPACITY - With High Efficiency Motor Furnaces (Continued)

UNIT MODEL	FURNACE MODEL	COIL MODEL ¹	W	STAGE	COOLING				
					RATED CFM	Net MBH		SEER	EER
						TOTAL	SENS.		
14.5 SEER HP WITH VARIABLE SPEED FURNACES²									
YHJF36S41S1	T*(8,L)X*A12	FC/MC/PC37A	14	-	1290	35.8	27.4	14.50	12.00
	T*(8,L)X*B12	FC/MC/PC43B	17	-	1300	35.8	27.4	14.50	12.00
	T*(8,L)X*C16	FC/MC/PC43C	21	-	1175	35.4	26.4	15.00	12.50
	T*(8,L)X*C20	FC/MC/PC43C	21	-	1250	36.0	27.4	15.00	12.50
	T*9X*B12	FC/MC/PC43B	17	-	1270	35.8	27.4	14.50	12.00
	T*9X*C16	FC/MC/PC43C	21	-	1260	36.0	27.4	14.50	12.00
	T*9X*C20	FC/MC/PC43C	21	-	1185	35.2	26.4	14.50	12.00
	Y*(8,L)(C,V)*C16	FC/MC/PC43C	21	-	1205	35.2	26.4	14.50	12.00
	Y*(8,L)(C,V)*C20	FC/MC/PC43C	21	-	1190	35.2	26.4	14.50	12.00
	Y*9(C,V)*C16	FC/MC/PC43C	21	-	1240	35.6	27.2	14.20	12.00
Y*9(C,V)*C20	FC/MC/PC43C	21	-	1200	35.2	26.4	14.35	12.00	
YHJF42S41S1	T*(8,L)X*C16	FC/MC62D	21	-	1360	40.5	31.0	15.00	12.50
	T*(8,L)X*C20	FC/MC62D	21	-	1485	40.5	31.8	15.00	12.50
	T*9X*C16	FC/MC62D	21	-	1460	40.0	30.8	14.50	12.00
	T*9X*C20	FC/MC62D	21	-	1460	40.5	31.0	14.50	12.00
	T*9X*D20	FC/MC62D	24	-	1425	40.5	31.0	14.50	12.00
	Y*(8,L)(C,V)*C16	FC/MC62D	21	-	1420	40.0	30.8	14.40	12.00
	Y*(8,L)(C,V)*C20	FC/MC62D	21	-	1410	40.5	30.8	14.50	12.00
	Y*9(C,V)*C20	FC/MC62D	21	-	1445	40.0	30.6	14.05	11.90
	Y*9(C,V)*D20	FC/MC62D	24	-	1455	40.0	30.6	14.25	12.00
YHJF48S41S1	T*(8,L)X*C16	FC/MC62D	21	-	1610	48.0	36.2	14.50	12.00
	T*(8,L)X*C20	FC/MC62D	21	-	1665	48.0	36.2	14.50	12.00
	T*9X*C16	FC/MC62D	21	-	1550	48.0	36.0	14.50	12.00
	T*9X*C20	FC/MC62D	21	-	1595	48.0	36.2	14.50	12.00
	T*9X*D20	FC/MC62D	24	-	1610	48.0	36.0	14.50	12.00
	Y*(8,L)(C,V)*C16	FC/MC62D	21	-	1635	48.0	36.0	14.50	12.00
	Y*(8,L)(C,V)*C20	FC/MC62D	21	-	1615	48.0	36.0	14.50	12.00
	Y*9(C,V)*C16	FC/MC62D	21	-	1590	47.5	36.0	14.35	12.00
	Y*9(C,V)*C20	FC/MC62D	21	-	1655	47.5	35.8	14.05	12.00
	Y*9(C,V)*D20	FC/MC62D	24	-	1630	47.5	35.8	14.25	12.00
YHJF60S41S1	T*(8,L)X*C20	FC/MC62D	21	1	835	44.0	27.0	14.50	20.25
				2	1665	57.0	39.5		12.00
	T*9X*C20	FC/MC62D	21	1	1220	48.5	31.6	14.50	21.10
				2	1595	56.5	38.5		12.00
	T*9X*D20	FC/MC62D	24	1	1240	48.5	31.8	14.50	21.30
				2	1645	56.5	39.0		12.00
	Y*(8,L)(C,V)*C20	FC/MC62D	21	1	1015	46.0	29.2	14.50	20.65
				2	1615	56.5	38.5		12.00
	Y*9(C,V)*C20	FC/MC62D	21	1	1040	46.5	29.4	14.50	20.55
				2	1655	56.0	38.5		12.00
	Y*9(C,V)*D20	FC/MC62D	24	1	1085	47.0	29.8	14.50	20.65
				2	1630	56.0	38.5		12.00

1. MC coils available with a factory installed horizontal drain pan. See price pages for specific model number.

2. Variable speed furnaces have B.O.D (Blower on Delay) standard.

HEATING PERFORMANCE - With Air Handler

UNIT MODEL*	AIR HANDLER	COIL ¹ MODEL	ARI HEATING ²							
			47°F			17°F			HSPF	
			MBH	COP	KW	MBH	COP	KW	STD	
14.5 SEER HP WITH MV - VARIABLE SPEED										
YHJF18S41S1	MV12B	FC/MC35B	18.0	3.76	1.40	11.0	2.48	1.30	8.50	
	MV12B	FC/MC43B	18.0	3.90	1.35	10.9	2.56	1.25	8.50	
YHJF24S41S1	MV12B	FC/MC35B	22.2	3.68	1.77	14.9	2.46	1.77	8.50	
	MV12B	FC/MC43B	22.2	3.82	1.70	14.9	2.54	1.72	8.50	
YHJF30S41S1	MV12B	FC/MC43B	30.0	3.88	2.27	18.8	2.68	2.06	9.00	
	MV16C	FC/MC43C	30.0	3.92	2.24	18.8	2.70	2.04	9.00	
YHJF36S41S1	MV12B	FC/MC43B	36.0	3.74	2.82	24.4	2.52	2.84	8.20	
	MV16C	FC/MC43C	36.0	3.74	2.82	24.2	2.52	2.81	9.00	
YHJF42S41S1	MV20D	FC/MC62D	40.5	4.02	2.95	26.0	2.76	2.76	9.00	
YHJF48S41S1	MV20D	FC/MC62D	48.0	3.82	3.68	31.8	2.60	3.58	9.00	
14.5 SEER HP WITH AV / SV / F*FV - VARIABLE SPEED										
YHJF18S41S1	AV*36	—	18.0	3.98	1.33	10.8	2.62	1.21	8.50	
YHJF24S41S1	AV*36	—	22.0	3.70	1.74	14.8	2.50	1.73	8.50	
YHJF30S41S1	AV*36	—	29.8	3.98	2.19	18.6	2.74	1.99	9.00	
YHJF36S41S1	AV*36	—	36.0	3.78	2.79	24.2	2.54	2.79	9.00	
14.5 SEER HP WITH AHP / SHP / AHX / F*FP										
YHJF18S41S1	AHX30	—	18.0	3.88	1.36	10.9	2.52	1.27	8.50	
YHJF24S41S1	AHX30	—	22.2	3.64	1.79	13.7	2.42	1.66	8.50	
	F6FP030	—	22.2	3.64	1.79	15.1	2.42	1.83	8.20	
	F6FP036	—	22.2	3.68	1.77	15.0	2.46	1.79	8.50	
	AHX36	—	22.4	3.70	1.77	15.1	2.46	1.80	8.50	
YHJF30S41S1	AHX36	—	30.0	4.00	2.20	18.7	2.76	1.99	9.00	
	F6FP042	—	30.0	4.00	2.20	18.7	2.76	1.99	9.00	
YHJF36S41S1	AHX36	—	36.0	3.82	2.76	24.2	2.56	2.77	9.00	
	AHX42	—	36.0	3.84	2.75	22.2	2.56	2.54	9.00	
	F6FP042	—	36.0	3.88	2.72	24.4	2.60	2.75	9.00	
YHJF42S41S1	AHX60	—	40.5	4.00	2.97	26.0	2.74	2.78	9.00	
	F6FP060	—	41.0	4.04	2.97	26.2	2.74	2.80	9.00	
YHJF48S41S1	AHX60	—	48.0	3.82	3.68	31.6	2.60	3.56	9.00	
	F6FP060	—	48.0	3.82	3.68	31.6	2.60	3.56	9.00	

See notes below.

HEATING CAPACITY - With Air Handler Coils

UNIT MODEL	AIR HANDLER	COIL ¹ MODEL	HEATING ²					
			STAGE	RATED CFM	NET MBH		HSPF	COP @ 47
					47 OD	17 OD		
14.5 SEER HP WITH MV - VARIABLE SPEED								
YHJF60S41S1	MV20D	FC/MC62D	1	1160	43.0	—	—	—
			2	1855	57.0	40.5	9.00	3.66
			2	1160	54.9	39.0	8.85	3.04
14.5 SEER HP WITH AHX								
YHJF60S41S1	AHX60	—	1	1160	43.1	—	—	—
			2	1855	58.0	40.0	9.00	3.72
			2	1170	57.5	40.0	8.90	3.24

Rated in accordance with DOE test procedures (Federal Register 12-27-79 and 3-18-88) and ARI Standards 210.

Cooling MBH based on 80°F entering air temperature, 50% RH, and rated air flow.

EER (Energy Efficiency Ratio) is the total cooling output in BTU's at 95°F outdoor ambient divided by the total electric power in watt-hours at those conditions.

SEER (Seasonal Energy Efficiency Ratio) is the total cooling output in BTU's during a normal annual usage period for cooling divided by the total electric power input in watt-hours during the same period.

1. Rated CFM same as for cooling.

2. Heating MBH based on ARI standards of 70° DB entering indoor air, 72% RH outdoor air with 25 feet of interconnecting piping and no supplemental electric heat operation.

CP equals MBH output divided by (total KW input x 3.412).

HSPF (Heating Seasonal Performance Factor) is the total heating output during a normal annual usage period for heating divided by the total electric power input during the same period.

— = Not Applicable.

HEATING CAPACITY - With High Efficiency Motor Furnaces

MODEL	FURNACE MODEL	COIL ¹ MODEL	ARI HEATING ²						
			47°F			17°F			HSPF
			MBH	COP	KW	MBH	COP	KW	STD
14.5 SEER HP WITH VARIABLE SPEED FURNACES³									
YHJF18S41S1	T*(8,L)X*A12	FC/MC/PC32A	17.9	3.84	1.37	10.8	2.54	1.25	9.00
	Y*(8,L)(C,V)*A12	FC/MC/PC32A	18.0	3.76	1.40	11.0	2.48	1.30	8.50
	Y*(8,L)(C,V)*B12	FC/MC/PC35B	18.0	3.84	1.37	10.9	2.50	1.28	8.50
	Y*(8,L)(C,V)*C16	FC/MC/PC35C	18.0	3.82	1.38	10.9	2.52	1.27	8.50
	Y*9(C,V)*B12	FC/MC/PC35B	18.0	3.80	1.39	10.9	2.50	1.28	8.50
	Y*9(C,V)*C16	FC/MC/PC35C	18.0	3.84	1.37	10.9	2.50	1.28	8.50
	Y*(8,L)(C,V)*A12	FC/MC/PC37A	18.0	3.90	1.35	10.9	2.58	1.24	8.50
Y*(8,L)(C,V)*B12	FC/MC/PC43B	18.0	3.80	1.39	10.8	2.52	1.26	8.50	
YHJF24S41S1	T*(8,L)X*A12	FC/MC/PC32A	22.0	3.72	1.73	14.8	2.48	1.75	8.50
	T*(8,L)X*B12	FC/MC/PC35B	22.0	3.74	1.72	14.8	2.48	1.75	8.50
	T*(8,L)X*C16	FC/MC/PC35C	22.0	3.76	1.71	14.8	2.50	1.73	8.50
	T*(8,L)X*C20	FC/MC/PC35C	22.0	3.76	1.71	14.8	2.48	1.75	8.50
	T*9X*B12	FC/MC/PC35B	22.0	3.72	1.73	14.8	2.48	1.75	8.50
	T*9X*C16	FC/MC/PC35C	22.0	3.78	1.71	14.7	2.50	1.72	9.00
	T*9X*C20	FC/MC/PC35C	22.2	3.72	1.75	14.9	2.48	1.76	8.50
	T*(8,L)X*A12	FC/MC/PC37A	22.2	3.88	1.68	14.8	2.56	1.69	8.50
	T*(8,L)X*B12	FC/MC/PC43B	22.0	3.88	1.66	14.8	2.58	1.68	8.50
	T*(8,L)X*C16	FC/MC/PC43C	22.0	3.88	1.66	14.8	2.58	1.68	8.50
	T*9X*B12	FC/MC/PC43B	22.2	3.88	1.68	14.8	2.56	1.69	8.50
	T*9X*C16	FC/MC/PC43C	22.0	3.80	1.70	14.8	2.54	1.71	9.00
	T*9X*C20	FC/MC/PC43C	22.0	3.74	1.72	14.9	2.50	1.75	8.50
	Y*(8,L)(C,V)*A12	FC/MC/PC32A	22.2	3.62	1.80	15.0	2.42	1.82	8.50
	Y*(8,L)(C,V)*B12	FC/MC/PC35B	22.0	3.56	1.81	14.9	2.40	1.82	8.50
	Y*(8,L)(C,V)*C16	FC/MC/PC35C	22.2	3.68	1.77	14.9	2.44	1.79	8.50
	Y*(8,L)(C,V)*C20	FC/MC/PC35C	21.8	3.60	1.77	14.8	2.42	1.79	8.50
	Y*9(C,V)*B12	FC/MC/PC35B	22.2	3.64	1.79	15.0	2.42	1.82	8.50
	Y*9(C,V)*C16	FC/MC/PC35C	22.2	3.70	1.76	15.0	2.44	1.80	8.50
	Y*9(C,V)*C20	FC/MC/PC35C	22.0	3.58	1.80	14.8	2.42	1.79	8.50
	Y*(8,L)(C,V)*A12	FC/MC/PC37A	22.4	3.76	1.75	15.0	2.50	1.76	8.50
Y*(8,L)(C,V)*B12	FC/MC/PC43B	22.0	3.68	1.75	14.9	2.46	1.77	8.50	
Y*(8,L)(C,V)*C16	FC/MC/PC43C	22.2	3.84	1.69	14.9	2.52	1.73	8.50	
Y*(8,L)(C,V)*C20	FC/MC/PC43C	22.0	3.72	1.73	14.8	2.50	1.73	8.50	
Y*9(C,V)*B12	FC/MC/PC43B	22.2	3.78	1.72	15.0	2.52	1.74	8.50	
Y*9(C,V)*C16	FC/MC/PC43C	22.2	3.82	1.70	14.9	2.52	1.73	8.50	
Y*9(C,V)*C20	FC/MC/PC43C	22.4	3.82	1.72	14.9	2.52	1.73	8.50	
YHJF30S41S1	T*(8,L)X*A12	FC/MC/PC37A	30.0	4.02	2.19	18.9	2.74	2.02	9.00
	T*(8,L)X*B12	FC/MC/PC43B	30.0	4.00	2.20	18.9	2.72	2.04	9.00
	T*(8,L)X*C16	FC/MC/PC43C	30.0	3.96	2.22	18.6	2.74	1.99	9.00
	T*9X*B12	FC/MC/PC43B	30.0	3.98	2.21	18.8	2.72	2.03	9.00
	T*9X*C16	FC/MC/PC43C	30.0	3.96	2.22	18.8	2.72	2.03	9.00
	Y*(8,L)(C,V)*A12	FC/MC/PC37A	30.0	3.80	2.31	19.1	2.62	2.14	8.50
	Y*(8,L)(C,V)*B12	FC/MC/PC43B	30.0	3.86	2.28	18.9	2.66	2.08	8.50
	Y*(8,L)(C,V)*C16	FC/MC/PC43C	30.0	3.92	2.24	18.7	2.70	2.03	9.00
	Y*(8,L)(C,V)*C20	FC/MC/PC43C	30.0	3.94	2.23	18.7	2.72	2.01	9.00
	Y*9(C,V)*B12	FC/MC/PC43B	30.0	3.84	2.29	19.0	2.64	2.11	8.50
	Y*9(C,V)*C16	FC/MC/PC43C	30.0	3.90	2.25	18.9	2.68	2.07	9.00
	Y*9(C,V)*C20	FC/MC/PC43C	30.0	3.90	2.25	18.8	2.70	2.04	9.00

For Notes See Page 9.

HEATING CAPACITY - With High Efficiency Motor Furnaces (Continued)

MODEL	FURNACE MODEL	COIL ¹ MODEL	ARI HEATING ²						
			47°F			17°F			HSPF
			MBH	COP	KW	MBH	COP	KW	STD
YHJF36S41S1	T*(8,L)X*A12	FC/MC/PC37A	36.0	3.80	2.78	24.6	2.54	2.84	8.50
	T*(8,L)X*B12	FC/MC/PC43B	36.0	3.80	2.78	24.6	2.54	2.84	8.50
	T*(8,L)X*C16	FC/MC/PC43C	36.0	3.78	2.79	24.0	2.56	2.75	9.00
	T*(8,L)X*C20	FC/MC/PC43C	36.0	3.88	2.72	24.4	2.60	2.75	9.00
	T*9X*B12	FC/MC/PC43B	36.0	3.80	2.78	24.6	2.54	2.84	8.50
	T*9X*C16	FC/MC/PC43C	36.0	3.82	2.76	24.4	2.56	2.79	8.50
	T*9X*C20	FC/MC/PC43C	36.0	3.74	2.82	24.2	2.52	2.81	8.50
	Y*(8,L)(C,V)*C16	FC/MC/PC43C	36.0	3.72	2.84	24.4	2.50	2.86	8.50
	Y*(8,L)(C,V)*C20	FC/MC/PC43C	36.0	3.74	2.82	24.2	2.52	2.81	8.50
	Y*9(C,V)*C16	FC/MC/PC43C	36.0	3.76	2.81	24.6	2.52	2.86	8.50
Y*9(C,V)*C20	FC/MC/PC43C	36.0	3.70	2.85	24.4	2.50	2.86	8.50	
YHJF42S41S1	T*(8,L)X*C16	FC/MC62D	40.5	4.06	2.92	26.0	2.78	2.74	9.00
	T*(8,L)X*C20	FC/MC62D	41.0	4.08	2.94	26.2	2.78	2.76	9.00
	T*9X*C16	FC/MC62D	41.0	3.98	3.02	26.2	2.72	2.82	9.00
	T*9X*C20	FC/MC62D	40.5	4.02	2.95	26.2	2.74	2.80	9.00
	T*9X*D20	FC/MC62D	40.5	4.02	2.95	26.0	2.76	2.76	9.00
	Y*(8,L)(C,V)*C16	FC/MC62D	41.0	3.96	3.03	26.4	2.70	2.86	9.00
	Y*(8,L)(C,V)*C20	FC/MC62D	41.0	4.00	3.00	26.2	2.74	2.80	9.00
	Y*9(C,V)*C16	FC/MC62D	41.5	3.86	3.15	26.6	2.64	2.95	9.00
	Y*9(C,V)*C20	FC/MC62D	41.0	3.90	3.08	26.4	2.68	2.89	9.00
Y*9(C,V)*D20	FC/MC62D	41.0	3.94	3.05	26.4	2.70	2.86	9.00	
YHJF48S41S1	T*(8,L)X*C16	FC/MC62D	48.0	3.78	3.72	32.0	2.56	3.66	9.00
	T*(8,L)X*C20	FC/MC62D	48.0	3.80	3.70	31.8	2.58	3.61	9.00
	T*9X*C16	FC/MC62D	48.0	3.76	3.74	32.0	2.56	3.66	9.00
	T*9X*C20	FC/MC62D	48.0	3.80	3.70	32.0	2.58	3.63	9.00
	T*9X*D20	FC/MC62D	48.0	3.76	3.74	32.0	2.56	3.66	9.00
	Y*(8,L)(C,V)*C20	FC/MC62D	48.0	3.76	3.74	32.0	2.56	3.66	9.00
	Y*9(C,V)*C16	FC/MC62D	48.0	3.72	3.78	32.2	2.54	3.71	9.00
	Y*9(C,V)*C20	FC/MC62D	48.0	3.68	3.82	32.4	2.50	3.80	9.00
Y*9(C,V)*D20	FC/MC62D	48.0	3.72	3.78	32.2	2.52	3.74	9.00	

1. MC coils available with a factory installed horizontal drain pan. See price pages for specific model number.

2. Heating MBH based on ARI standards of 70° DB entering indoor air, 72% RH outdoor air with 25 feet of interconnecting piping and no supplemental electric heat operation.

3. Variable speed furnaces have B.O.D (Blower on Delay) standard.

CP equals MBH output divided by (total KW input x 3.412).

HSPF (Heating Seasonal Performance Factor) is the total heating output during a normal annual usage period for heating divided by the total electric power input during the same period.

— = Not Applicable.

HEATING CAPACITY - With High Efficiency Motor Furnaces

UNIT MODEL	VARIABLE SPEED FURNACE MODEL	COIL MODEL ¹	HEATING ²					
			STAGE	RATED CFM	NET MBH		HSPF	COP @ 47
					47 OD	17 OD		
14.5 SEER HP WITH VARIABLE SPEED FURNACES³								
YHJF60S41S1	T*(8,L)X*C20	FC/MC62D	1	835	42.0	—	—	2.98
			2	1665	57.0	39.5	9.00	3.64
			2	835	56.5	38.5	8.85	2.62
	T*9X*C20	FC/MC62D	1	1220	43.5	—	—	3.38
			2	1595	57.0	40.0	9.00	3.58
			2	1220	55.6	39.0	8.60	3.08
	T*9X*D20	FC/MC62D	1	1240	43.5	—	—	3.42
			2	1645	57.0	40.0	9.00	3.60
			2	1240	55.6	39.0	8.65	3.10
	Y*(8,L)(C,V)*C20	FC/MC62D	1	1015	42.5	—	—	3.20
			2	1615	57.0	40.0	9.00	3.58
			2	1015	55.6	39.0	8.75	2.86
	Y*9(C,V)*C20	FC/MC62D	1	1040	43.0	—	—	3.20
			2	1655	57.0	40.5	9.00	3.54
			2	1040	54.9	39.0	8.70	2.88
	Y*9(C,V)*D20	FC/MC62D	1	1085	43.0	—	—	3.26
			2	1630	57.0	40.0	9.00	3.54
			2	1085	55.6	39.0	8.65	2.94

1. MC coils available with a factory installed horizontal drain pan. See price pages for specific model number.

2. Heating MBH based on ARI standards of 70° DB entering indoor air, 72% RH outdoor air with 25 feet of interconnecting piping and no supplemental electric heat operation.

3. Variable speed furnaces have B.O.D (Blower on Delay) standard.

CP equals MBH output divided by (total KW input x 3.412).

HSPF (Heating Seasonal Performance Factor) is the total heating output during a normal annual usage period for heating divided by the total electric power input during the same period.

— = Not Applicable.

ACCESSORIES

Refer to Price Manual for specific model numbers.

Start Assist Kit - Provides starting torque for low voltage applications.

Blower Time Delay - Available to increase efficiency when installed. Installs on indoor section and maintains blower for approximately one minute after cooling thermostat has been satisfied.

Low Temperature Cutout (2LT06700224) - Prevents heat

pump operation below -10°F ambient temperature.

Thermal Expansion Valve Kit - 1TVM4 Series TXV kit used when required.

Outdoor Thermostat (2TD06700124) - Provides additional staging of supplemental electric heat.

Room Thermostats - A wide selection of matching thermostats is available to provide features required for any installation.

* For the most current accessory information, refer to the price book or consult factory.

SOUND LEVEL - TYPICAL OCTAVE BAND SPECTRUM (without tone adjustment)

Size	Test Condition	63	125	250	500	1000	2000	4000	8000	dBA	SQI
	RSS Sound Power Calibration 1091 402	82.8	85.4	85.9	85.3	88.1	88.6	86.6	83.9	-	-
18	Cooling Mode	67.3	69.2	64.6	67.3	65.5	61.5	58.2	51.8	70.0	19.21
	Heating Mode	68.9	69.0	64.0	66.4	66.6	59.6	56.4	52.6	69.7	19.17
24	Cooling Mode	70.0	73.6	64.0	70.0	71.8	63.2	57.3	52.3	73.9	19.19
	Heating Mode	72.2	71.0	68.5	74.1	71.9	63.4	59.8	53.4	75.4	19.14
30	Cooling Mode	70.5	68.8	64.3	65.3	65.5	60.3	55.8	50.6	69.0	19.01
	Heating Mode	72.2	70.1	67.5	66.7	69.4	62.5	58.3	52.7	72.0	19.03
36	Cooling Mode	70.9	69.3	65.3	66.4	66.3	59.7	56.7	50.8	69.6	19.14
	Heating Mode	73.2	70.1	66.9	68.5	68.4	61.6	59.4	55.5	71.7	19.12
42	Cooling Mode	71.7	69.5	72.1	69.0	71.3	60.6	56.9	54.0	73.3	19.01
	Heating Mode	72.6	72.6	68.1	70.5	70.9	62.7	59.2	56.9	73.6	19.02
48	Cooling Mode	71.0	71.0	68.4	68.1	67.9	60.1	55.8	51.3	70.8	19.11
	Heating Mode	73.6	72.5	74.0	73.6	75.8	64.0	63.2	56.8	77.6	19.08
60	Cooling Mode - High Stage	71.2	69.4	71.4	73.2	71.2	61.1	57.6	52.8	74.7	19.09
	Heating Mode - High Stage	71.6	72.7	69.6	71.3	72.4	63.4	61.5	57.4	75.0	19.05

* Rated in accordance with ARI 270-2008 Standards.

TYPICAL INSTALLATION

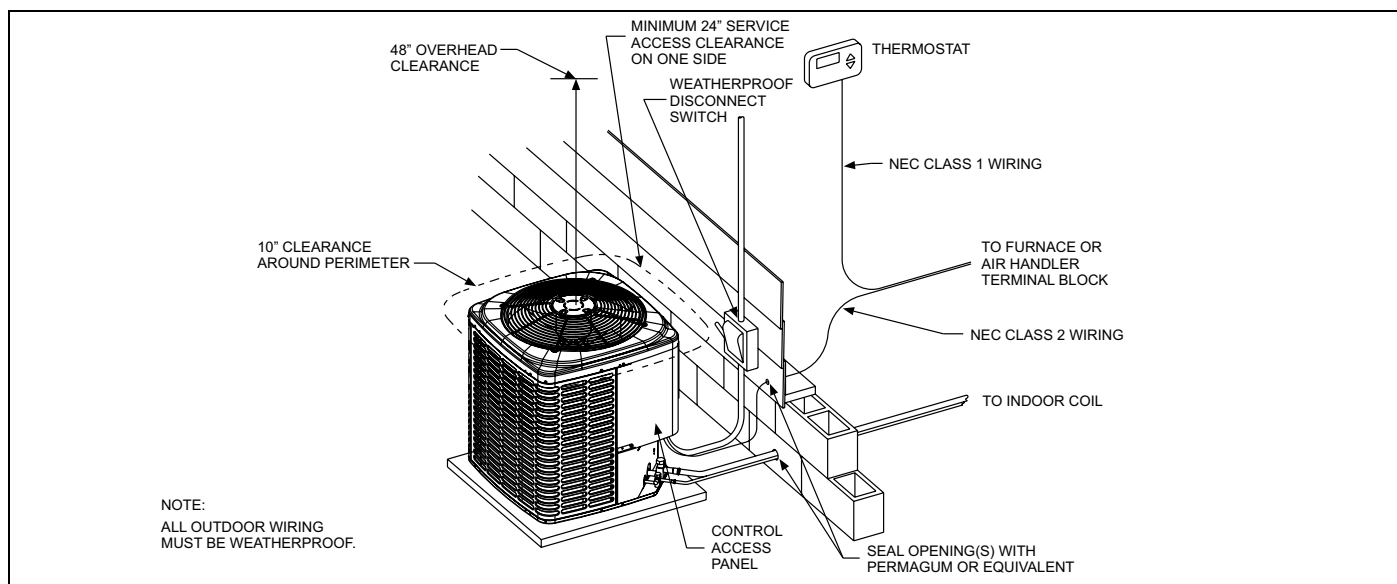

TYPICAL FIELD WIRING

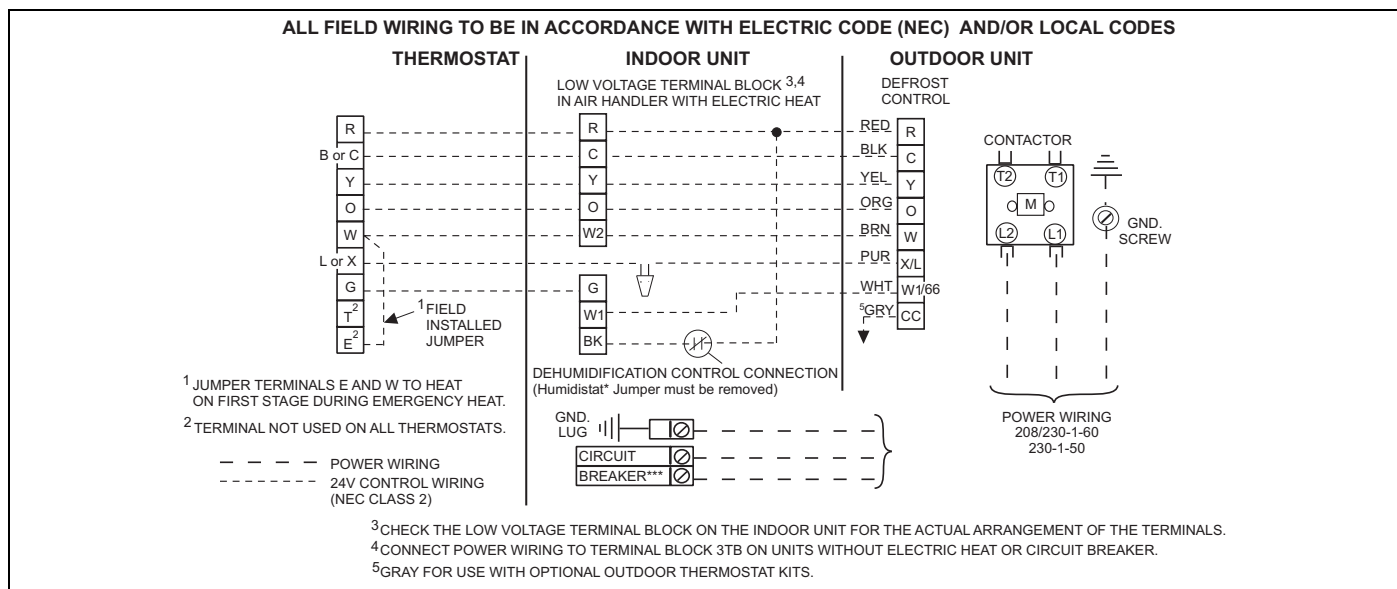

COOLING PERFORMANCE DATA																
CONDENSING UNIT MODEL NO.		YHJF18S41S1														
INDOOR COIL MODEL NO.		AHX30														
CONDENSING ENTERING AIR TEMPERATURE	IDCFM	400					600					800				
	ID DB (°F)	80	80	75	80	80	80	80	75	80	80	80	80	75	80	80
	ID WB (°F)	57	62	62	67	72	57	62	62	67	72	57	62	62	67	72
65	T.C.	17.2	18.8	18.8	20.5	22.2	19.2	19.9	20.1	21.7	22.9	21.2	20.9	21.3	22.8	23.6
	S.C.	16.8	14.9	12.9	12.9	11.0	18.8	17.7	15.2	14.7	11.7	20.8	20.5	17.4	16.5	12.5
	KW	0.9	0.9	0.9	0.9	0.9	0.9	1.0	1.0	1.0	1.0	1.0	1.0	1.0	1.0	1.0
75	T.C.	16.4	17.9	17.9	19.7	21.3	18.4	19.1	19.0	20.8	22.1	20.4	20.2	20.2	21.8	22.9
	S.C.	16.1	14.5	12.5	12.5	10.5	18.0	17.1	14.8	14.4	11.5	20.0	19.8	17.0	16.3	12.4
	KW	1.0	1.0	1.0	1.0	1.0	1.1	1.1	1.1	1.1	1.1	1.2	1.2	1.2	1.2	1.2
85	T.C.	15.7	17.0	17.0	18.9	20.4	17.7	18.3	18.0	19.9	21.3	19.6	19.5	19.1	20.8	22.1
	S.C.	15.4	14.1	12.1	12.1	10.1	17.3	16.6	14.3	14.2	11.2	19.2	19.1	16.6	16.2	12.2
	KW	1.1	1.1	1.1	1.2	1.2	1.2	1.2	1.2	1.2	1.3	1.3	1.3	1.3	1.3	1.3
95	T.C.	15.0	16.1	16.1	18.1	19.6	16.9	17.4	17.0	19.0	20.4	18.8	18.8	18.0	19.8	21.3
	S.C.	14.7	13.7	11.6	11.8	9.7	16.5	16.0	13.9	13.9	10.9	18.4	18.4	16.2	16.0	12.1
	KW	1.3	1.3	1.3	1.3	1.3	1.4	1.4	1.4	1.4	1.4	1.5	1.5	1.5	1.5	1.5
105	T.C.	14.0	14.7	14.8	16.7	18.4	15.9	16.2	15.7	17.6	19.2	17.7	17.7	16.6	18.5	20.1
	S.C.	13.7	13.1	11.0	11.2	9.2	15.5	15.2	13.3	13.4	10.4	17.3	17.3	15.6	15.6	11.6
	KW	1.4	1.4	1.4	1.5	1.5	1.5	1.5	1.5	1.5	1.6	1.6	1.6	1.6	1.6	1.7
115	T.C.	13.1	13.4	13.4	15.4	17.2	14.8	15.0	14.4	16.2	18.0	16.6	16.6	15.3	17.1	18.8
	S.C.	12.8	12.5	10.5	10.6	8.7	14.5	14.4	12.7	12.9	9.9	16.2	16.2	15.0	15.1	11.2
	KW	1.6	1.6	1.6	1.6	1.7	1.7	1.7	1.7	1.7	1.7	1.8	1.8	1.8	1.8	1.8
125	T.C.	12.2	12.1	12.1	14.0	16.1	13.8	13.8	13.0	14.9	16.8	15.5	15.5	14.0	15.7	17.5
	S.C.	11.9	11.9	9.9	10.1	8.2	13.5	13.5	12.1	12.3	9.5	15.1	15.1	14.0	14.6	10.7
	KW	1.7	1.7	1.7	1.8	1.8	1.8	1.8	1.8	1.9	1.9	2.0	2.0	1.9	2.0	2.0

NOTE: ALL CAPACITIES INCLUDE INDOOR FAN HEAT AT 1250 BTUH/1000 CFM.

Multipliers for determining the performance with other indoor sections.

NOTE: For dry bulb temperatures different than those listed (between 73-87 F), sensible capacity increases by 1060 BTUH per 1000 CFM per degree above the listed temperature and decreases by 1060 BTUH per 1000 CFM per degree below the listed temperature.

Air Handler	Coil	T.C.	S.C.	KW
AV*36	-	1.00	1.00	1.08
MV12B	FC/MC35B	1.00	0.98	1.08
MV12B	FC/MC43B	1.00	1.00	1.08

Variable Speed Furnace	Coil	T.C.	S.C.	KW
T*(8,L)X*A12	FC/MC/PC32A	1.00	0.98	1.08
Y*(8,L)(C,V)*A12	FC/MC/PC32A	1.00	0.98	1.08
Y*(8,L)(C,V)*B12	FC/MC/PC35B	1.00	1.01	1.08
Y*(8,L)(C,V)*C16	FC/MC/PC35C	1.00	0.98	1.08
Y*9(C,V)*B12	FC/MC/PC35B	1.00	0.98	1.08
Y*9(C,V)*C16	FC/MC/PC35C	1.00	1.01	1.08
Y*(8,L)(C,V)*A12	FC/MC/PC37A	1.00	1.00	1.08
Y*(8,L)(C,V)*B12	FC/MC/PC43B	1.00	0.96	1.08

COOLING PERFORMANCE DATA																
CONDENSING UNIT MODEL NO.		YHJF24S41S1														
INDOOR COIL MODEL NO.		AHX30														
CONDENSING ENTERING AIR TEMPERATURE	IDCFM	600					800					1000				
	ID DB (°F)	80	80	75	80	80	80	80	75	80	80	80	80	75	80	80
	ID WB (°F)	57	62	62	67	72	57	62	62	67	72	57	62	62	67	72
65	T.C.	21.7	23.6	23.5	25.2	26.6	23.4	24.1	24.3	26.0	27.2	25.1	24.6	25.1	26.9	27.8
	S.C.	21.4	19.4	16.6	16.2	13.7	23.1	21.8	18.5	17.9	14.3	24.8	24.3	20.5	19.5	15.0
	KW	1.2	1.2	1.2	1.2	1.2	1.3	1.3	1.3	1.3	1.3	1.4	1.4	1.4	1.4	1.4
75	T.C.	20.8	22.3	22.2	24.0	25.7	22.4	23.0	23.0	24.8	26.3	24.1	23.8	23.8	25.7	26.9
	S.C.	20.5	18.8	16.0	15.7	13.1	22.1	21.1	18.0	17.5	13.9	23.8	23.5	19.9	19.2	14.6
	KW	1.4	1.4	1.4	1.4	1.4	1.4	1.4	1.4	1.5	1.5	1.5	1.5	1.5	1.5	1.5
85	T.C.	19.8	20.9	20.9	22.9	24.8	21.4	21.9	21.6	23.7	25.5	23.1	22.9	22.4	24.5	26.1
	S.C.	19.5	18.2	15.4	15.3	12.5	21.2	20.4	17.4	17.1	13.4	22.8	22.6	19.4	18.9	14.3
	KW	1.5	1.5	1.5	1.5	1.6	1.6	1.6	1.6	1.6	1.6	1.7	1.7	1.7	1.7	1.7
95	T.C.	18.8	19.5	19.6	21.8	23.9	20.5	20.8	20.3	22.5	24.6	22.1	22.1	21.1	23.2	25.3
	S.C.	18.6	17.5	14.8	14.8	11.9	20.2	19.7	16.8	16.7	12.9	21.8	21.8	18.8	18.7	14.0
	KW	1.7	1.7	1.7	1.7	1.7	1.8	1.8	1.7	1.8	1.8	1.9	1.9	1.8	1.9	1.9
105	T.C.	17.7	18.0	18.0	20.2	22.4	19.2	19.3	18.7	20.9	23.1	20.7	20.7	19.4	21.6	23.7
	S.C.	17.4	16.8	14.1	14.2	11.3	18.9	18.7	16.1	16.1	12.4	20.5	20.5	18.2	18.1	13.5
	KW	1.9	1.9	1.9	1.9	2.0	2.0	2.0	1.9	2.0	2.0	2.1	2.1	2.0	2.1	2.1
115	T.C.	16.5	16.4	16.4	18.7	20.9	17.9	17.9	17.0	19.3	21.6	19.4	19.4	17.7	20.0	22.2
	S.C.	16.3	16.1	13.4	13.5	10.8	17.7	17.6	15.4	15.5	11.9	19.2	19.2	17.5	17.5	13.0
	KW	2.1	2.1	2.1	2.1	2.2	2.2	2.2	2.1	2.2	2.2	2.3	2.3	2.2	2.3	2.3
125	T.C.	15.3	14.8	14.8	17.1	19.4	16.7	16.4	15.4	17.7	20.0	18.1	18.1	16.1	18.3	20.6
	S.C.	15.1	14.8	12.7	12.9	10.2	16.5	16.4	14.7	14.9	11.3	17.8	17.8	16.1	16.9	12.5
	KW	2.2	2.2	2.2	2.3	2.4	2.4	2.4	2.4	2.4	2.4	2.5	2.5	2.5	2.5	2.5

NOTE: ALL CAPACITIES INCLUDE INDOOR FAN HEAT AT 1250 BTUH/1000 CFM.

Multipliers for determining the performance with other indoor sections.

NOTE: For dry bulb temperatures different than those listed (between 73-87 F), sensible capacity increases by 1060 BTUH per 1000 CFM per degree above the listed temperature and decreases by 1060 BTUH per 1000 CFM per degree below the listed temperature.

Air Handler	Coil	T.C.	S.C.	KW
AHX36	-	1.01	1.02	1.03
AV*36	-	1.00	0.98	1.02
F6FP030	-	1.00	1.01	1.07
F6FP036	-	1.00	1.02	1.02
MV12B	FC/MC35B	1.00	1.01	1.02
MV12B	FC/MC43B	1.03	1.05	1.05

Variable Speed Furnace	Coil	T.C.	S.C.	KW
T*(8,L)X*A12	FC/MC/PC32A	1.01	1.01	1.03
T*(8,L)X*B12	FC/MC/PC35B	1.01	1.04	1.03
T*(8,L)X*C16	FC/MC/PC35C	1.02	1.05	1.04
T*(8,L)X*C20	FC/MC/PC35C	1.02	1.06	1.04
T*9X*B12	FC/MC/PC35B	1.01	1.01	1.03
T*9X*C16	FC/MC/PC35C	1.01	1.01	1.03
T*9X*C20	FC/MC/PC35C	1.01	1.01	1.03
T*(8,L)X*A12	FC/MC/PC37A	1.03	1.05	1.05
T*(8,L)X*B12	FC/MC/PC43B	1.03	1.06	1.05

Variable Speed Furnace	Coil	T.C.	S.C.	KW
T*(8,L)X*C16	FC/MC/PC43C	1.03	1.06	1.05
T*9X*B12	FC/MC/PC43B	1.03	1.05	1.05
T*9X*C16	FC/MC/PC43C	1.02	1.02	1.04
T*9X*C20	FC/MC/PC43C	1.02	1.02	1.04
Y*(8,L)(C,V)*A12	FC/MC/PC32A	1.00	1.00	1.07
Y*(8,L)(C,V)*B12	FC/MC/PC35B	0.99	0.98	1.02
Y*(8,L)(C,V)*C16	FC/MC/PC35C	1.01	1.04	1.03
Y*(8,L)(C,V)*C20	FC/MC/PC35C	0.99	0.97	1.02
Y*9(C,V)*B12	FC/MC/PC35B	1.00	1.00	1.07
Y*9(C,V)*C16	FC/MC/PC35C	1.02	1.06	1.04
Y*9(C,V)*C20	FC/MC/PC35C	0.99	0.98	1.02
Y*(8,L)(C,V)*A12	FC/MC/PC37A	1.02	1.05	1.04
Y*(8,L)(C,V)*B12	FC/MC/PC43B	1.00	0.99	1.02
Y*(8,L)(C,V)*C16	FC/MC/PC43C	1.03	1.08	1.05
Y*(8,L)(C,V)*C20	FC/MC/PC43C	1.01	1.00	1.03
Y*9(C,V)*B12	FC/MC/PC43B	1.02	1.05	1.04
Y*9(C,V)*C16	FC/MC/PC43C	1.03	1.05	1.05
Y*9(C,V)*C20	FC/MC/PC43C	1.03	1.08	1.05

COOLING PERFORMANCE DATA																
CONDENSING UNIT MODEL NO.		YHJF30S41S1														
INDOOR COIL MODEL NO.		AHX36														
CONDENSING ENTERING AIR TEMPERATURE	IDCFM	800					1000					1200				
	ID DB (°F)	80	80	75	80	80	80	80	75	80	80	80	80	75	80	80
	ID WB (°F)	57	62	62	67	72	57	62	62	67	72	57	62	62	67	72
65	T.C.	28.4	30.2	30.1	33.0	34.3	30.2	31.2	31.2	33.5	34.8	32.0	32.2	32.2	34.0	35.3
	S.C.	28.4	26.3	22.5	22.3	18.2	30.2	29.6	24.6	23.7	18.7	32.0	32.2	26.8	25.1	19.1
	KW	1.5	1.5	1.5	1.6	1.5	1.6	1.6	1.6	1.6	1.6	1.7	1.7	1.7	1.7	1.7
75	T.C.	27.3	28.7	28.7	31.5	33.2	29.0	29.7	29.6	32.1	33.7	30.7	30.6	30.6	32.7	34.2
	S.C.	27.3	25.7	21.8	21.6	17.7	29.0	28.4	23.9	23.2	18.2	30.7	30.6	26.1	24.8	18.7
	KW	1.7	1.7	1.7	1.7	1.7	1.8	1.8	1.8	1.8	1.8	1.9	1.9	1.9	1.8	1.8
85	T.C.	26.2	27.2	27.2	30.0	32.2	27.8	28.1	28.1	30.7	32.6	29.5	29.0	29.0	31.4	33.1
	S.C.	26.2	25.0	21.1	21.0	17.1	27.8	27.3	23.3	22.8	17.7	29.5	29.0	25.4	24.6	18.4
	KW	1.8	1.9	1.9	1.9	1.9	1.9	1.9	1.9	2.0	2.0	2.0	2.0	2.0	2.0	2.0
95	T.C.	25.1	25.8	25.8	28.6	31.1	26.7	26.6	26.6	29.3	31.5	28.2	27.3	27.3	30.1	32.0
	S.C.	25.1	24.4	20.4	20.4	16.5	26.7	26.1	22.6	22.4	17.3	28.2	27.3	24.7	24.4	18.1
	KW	2.0	2.0	2.0	2.0	2.1	2.1	2.1	2.1	2.1	2.1	2.2	2.1	2.1	2.2	2.2
105	T.C.	23.7	23.8	23.9	26.9	29.5	25.2	25.1	24.6	27.6	29.9	26.7	26.3	25.4	28.2	30.3
	S.C.	23.7	23.4	19.6	19.7	15.7	25.2	25.1	21.7	21.7	16.6	26.7	26.3	23.9	23.7	17.5
	KW	2.2	2.2	2.2	2.3	2.3	2.3	2.3	2.3	2.4	2.4	2.4	2.4	2.4	2.4	2.4
115	T.C.	22.2	21.9	21.9	25.2	27.8	23.7	23.6	22.7	25.8	28.3	25.2	25.2	23.4	26.4	28.7
	S.C.	22.2	21.9	18.7	19.0	15.0	23.7	23.6	20.9	21.0	16.0	25.2	25.2	23.1	23.0	17.0
	KW	2.4	2.4	2.4	2.5	2.5	2.5	2.5	2.5	2.6	2.6	2.6	2.6	2.6	2.7	2.7
125	T.C.	20.8	19.9	20.0	23.5	26.2	22.2	22.1	20.7	24.0	26.7	23.7	24.2	21.5	24.5	27.1
	S.C.	20.8	19.9	17.8	18.3	14.2	22.2	22.1	20.1	20.3	15.3	23.7	24.2	21.5	22.3	16.4
	KW	2.6	2.6	2.6	2.7	2.8	2.7	2.8	2.7	2.8	2.8	2.8	2.9	2.9	2.9	2.9

NOTE: ALL CAPACITIES INCLUDE INDOOR FAN HEAT AT 1250 BTUH/1000 CFM.

Multipliers for determining the performance with other indoor sections.

NOTE: For dry bulb temperatures different than those listed (between 73-87 F), sensible capacity increases by 1060 BTUH per 1000 CFM per degree above the listed temperature and decreases by 1060 BTUH per 1000 CFM per degree below the listed temperature.

Air Handler	Coil	T.C.	S.C.	KW
AV*36	—	0.99	0.98	1.09
F6FP42	—	0.99	0.98	1.09
MV12B	FC/MC43B	0.99	0.97	1.09
MV16C	FC/MC43C	0.99	0.97	1.09

Variable Speed Furnace	Coil	T.C.	S.C.	KW
T*(8,L)X*A12	FC/MC/PC37A	1.00	1.04	1.10
T*(8,L)X*B12	FC/MC/PC43B	1.01	1.05	1.11
T*(8,L)X*C16	FC/MC/PC43C	0.99	0.97	1.09
T*9X*B12	FC/MC/PC43B	1.00	1.04	1.10
T*9X*C16	FC/MC/PC43C	1.00	1.02	1.10
Y*(8,L)(C,V)*A12	FC/MC/PC37A	0.97	0.96	1.11
Y*(8,L)(C,V)*B12	FC/MC/PC43B	0.98	0.96	1.08
Y*(8,L)(C,V)*C16	FC/MC/PC43C	0.99	0.97	1.09
Y*(8,L)(C,V)*C20	FC/MC/PC43C	0.99	0.97	1.09
Y*9(C,V)*B12	FC/MC/PC43B	0.99	0.99	1.13
Y*9(C,V)*C16	FC/MC/PC43C	0.99	1.00	1.09
Y*9(C,V)*C20	FC/MC/PC43C	0.99	0.97	1.09

COOLING PERFORMANCE DATA																
CONDENSING UNIT MODEL NO.		YHJF36S41S1														
INDOOR COIL MODEL NO.		AHX36														
CONDENSING ENTERING AIR TEMPERATURE	IDCFM	1000					1200					1400				
	ID DB (°F)	80	80	75	80	80	80	80	75	80	80	80	80	75	80	80
	ID WB (°F)	57	62	62	67	72	57	62	62	67	72	57	62	62	67	72
65	T.C.	34.5	36.4	37.1	40.1	42.7	36.2	37.6	37.8	41.2	43.4	38.0	38.7	38.5	42.3	44.1
	S.C.	34.5	36.4	32.5	32.1	26.5	36.2	37.6	34.8	34.5	27.5	38.0	38.7	37.1	36.9	28.4
	KW	1.9	2.0	2.0	2.0	2.0	2.0	2.1	2.1	2.1	2.1	2.1	2.1	2.1	2.2	2.2
75	T.C.	33.0	34.5	34.9	38.1	41.1	34.7	35.6	35.7	39.2	41.7	36.4	36.6	36.5	40.2	42.4
	S.C.	33.0	34.5	31.4	31.1	25.5	34.7	35.6	33.8	33.5	26.5	36.4	36.6	36.1	35.9	27.5
	KW	2.2	2.2	2.2	2.3	2.3	2.3	2.3	2.3	2.3	2.4	2.4	2.4	2.4	2.4	2.4
85	T.C.	31.5	32.6	32.8	36.2	39.4	33.2	33.6	33.6	37.1	40.0	34.9	34.5	34.4	38.1	40.6
	S.C.	31.5	32.6	30.2	30.1	24.5	33.2	33.6	32.7	32.5	25.6	34.9	34.5	34.4	34.9	26.7
	KW	2.4	2.5	2.5	2.5	2.6	2.5	2.6	2.6	2.6	2.6	2.6	2.6	2.6	2.7	2.7
95	T.C.	29.9	30.7	30.6	34.3	37.8	31.6	31.6	31.5	35.1	38.3	33.3	32.4	32.4	36.0	38.9
	S.C.	29.9	30.7	29.1	29.2	23.4	31.6	31.6	31.5	31.5	24.6	33.3	32.4	32.4	33.9	25.8
	KW	2.7	2.7	2.7	2.8	2.8	2.8	2.8	2.8	2.9	2.9	2.9	2.9	2.9	2.9	2.9
105	T.C.	28.2	28.1	28.0	31.8	35.3	29.8	29.4	28.9	32.6	35.9	31.4	30.8	29.7	33.4	36.6
	S.C.	28.2	28.1	27.6	28.0	22.3	29.8	29.4	28.9	30.3	23.6	31.4	30.8	29.7	32.7	24.8
	KW	3.0	3.0	3.0	3.0	3.1	3.1	3.1	3.1	3.1	3.2	3.2	3.2	3.2	3.2	3.2
115	T.C.	26.5	25.5	25.3	29.4	32.7	28.0	27.3	26.2	30.1	33.5	29.5	29.2	27.1	30.9	34.2
	S.C.	26.5	25.5	25.3	26.8	21.2	28.0	27.3	26.2	29.2	22.5	29.5	29.2	27.1	30.9	23.8
	KW	3.3	3.3	3.3	3.3	3.3	3.4	3.4	3.4	3.4	3.4	3.5	3.5	3.4	3.5	3.5
125	T.C.	24.7	22.9	22.6	27.0	30.2	26.2	25.2	23.6	27.7	31.0	27.6	27.6	24.5	28.3	31.9
	S.C.	24.7	22.9	22.6	25.6	20.1	26.2	25.2	23.6	27.7	21.4	27.6	27.6	24.5	28.3	22.7
	KW	3.5	3.5	3.5	3.6	3.6	3.6	3.6	3.6	3.7	3.7	3.8	3.7	3.7	3.7	3.8

NOTE: ALL CAPACITIES INCLUDE INDOOR FAN HEAT AT 1250 BTUH/1000 CFM.

Multipliers for determining the performance with other indoor sections.

NOTE: For dry bulb temperatures different than those listed (between 73-87 F), sensible capacity increases by 1060 BTUH per 1000 CFM per degree above the listed temperature and decreases by 1060 BTUH per 1000 CFM per degree below the listed temperature.

Air Handler	Coil	T.C.	S.C.	KW
AHX42	—	1.01	1.01	1.03
AV*36	—	1.00	0.99	1.06
F6FP042	—	1.02	1.04	1.03
MV12B	FC/MC43B	1.00	1.00	1.06
MV16C	FC/MC43C	0.99	0.99	1.05

Variable Speed Furnace	Coil	T.C.	S.C.	KW
T*(8,L)X*A12	FC/MC/PC37A	1.01	1.03	1.07
T*(8,L)X*B12	FC/MC/PC43B	1.01	1.03	1.07
T*(8,L)X*C16	FC/MC/PC43C	1.00	0.99	1.02
T*(8,L)X*C20	FC/MC/PC43C	1.02	1.03	1.03
T*9X*B12	FC/MC/PC43B	1.01	1.03	1.07
T*9X*C16	FC/MC/PC43C	1.02	1.03	1.08
T*9X*C20	FC/MC/PC43C	0.99	0.99	1.05
Y*(8,L)(C,V)*C16	FC/MC/PC43C	0.99	0.99	1.02
Y*(8,L)(C,V)*C20	FC/MC/PC43C	0.99	0.99	1.05
Y*9(C,V)*C16	FC/MC/PC43C	1.01	1.02	1.06
Y*9(C,V)*C20	FC/MC/PC43C	0.99	0.99	1.05

COOLING PERFORMANCE DATA																
CONDENSING UNIT MODEL NO.		YHJF42S41S1														
INDOOR COIL MODEL NO.		AHX60														
CONDENSING ENTERING AIR TEMPERATURE	IDCFM	1155					1355					1555				
	ID DB (°F)	80	80	75	80	80	80	80	75	80	80	80	80	75	80	80
	ID WB (°F)	57	62	62	67	72	57	62	62	67	72	57	62	62	67	72
65	T.C.	38.5	40.6	41.2	44.8	48.2	40.3	41.9	41.0	45.8	49.3	42.2	43.3	40.7	46.7	50.4
	S.C.	38.5	35.5	30.5	30.2	24.7	40.3	39.2	32.0	32.1	25.8	42.2	42.9	33.6	33.9	26.8
	KW	2.2	2.2	2.2	2.2	2.4	2.3	2.3	2.3	2.3	2.4	2.3	2.3	2.3	2.5	2.5
75	T.C.	36.9	38.6	39.0	42.8	46.3	38.7	39.7	39.1	43.7	47.3	40.6	40.8	39.2	44.6	48.3
	S.C.	36.9	34.8	29.6	29.4	23.8	38.7	37.7	31.3	31.3	24.9	40.6	40.6	33.0	33.2	26.0
	KW	2.5	2.5	2.5	2.5	2.6	2.6	2.6	2.6	2.6	2.7	2.6	2.7	2.6	2.7	2.8
85	T.C.	35.3	36.7	36.9	40.8	44.3	37.2	37.5	37.2	41.6	45.3	39.0	38.3	37.6	42.4	46.2
	S.C.	35.3	34.0	28.6	28.6	23.0	37.2	36.2	30.5	30.5	24.1	39.0	38.3	32.5	32.4	25.1
	KW	2.8	2.8	2.8	2.8	2.9	2.9	2.9	2.9	2.9	3.0	3.0	3.0	2.9	3.0	3.1
95	T.C.	33.7	34.8	34.7	38.8	42.3	35.6	35.3	35.4	39.6	43.2	37.4	35.8	36.1	40.3	44.1
	S.C.	33.7	33.3	27.7	27.7	22.2	35.6	34.7	29.8	29.7	23.2	37.4	35.8	31.9	31.6	24.3
	KW	3.0	3.1	3.1	3.1	3.1	3.2	3.2	3.2	3.2	3.2	3.3	3.3	3.2	3.3	3.4
105	T.C.	31.7	32.2	31.4	35.9	39.8	33.4	33.3	32.3	36.7	40.5	35.1	34.3	33.1	37.5	41.3
	S.C.	31.7	31.6	26.3	26.6	21.1	33.4	33.1	28.5	28.6	22.2	35.1	34.3	30.7	30.6	23.3
	KW	3.3	3.4	3.4	3.4	3.5	3.5	3.5	3.5	3.5	3.6	3.6	3.5	3.5	3.6	3.7
115	T.C.	29.7	29.7	28.2	33.0	37.2	31.2	31.2	29.2	33.8	37.8	32.7	32.7	30.2	34.7	38.5
	S.C.	29.7	29.7	24.9	25.4	20.1	31.2	31.2	27.2	27.5	21.2	32.7	32.7	29.5	29.6	22.3
	KW	3.7	3.7	3.7	3.7	3.8	3.8	3.8	3.8	3.8	3.9	3.9	3.8	3.8	3.9	4.0
125	T.C.	27.6	27.1	25.0	30.1	34.6	29.0	29.2	26.1	31.0	35.1	30.4	31.2	27.2	31.9	35.6
	S.C.	27.6	27.1	23.6	24.3	19.1	29.0	29.2	25.9	26.4	20.2	30.4	31.2	27.2	28.6	21.4
	KW	4.0	4.0	4.0	3.9	4.1	4.1	4.1	4.1	4.1	4.2	4.2	4.1	4.1	4.2	4.3

NOTE: ALL CAPACITIES INCLUDE INDOOR FAN HEAT AT 1250 BTUH/1000 CFM.

Multipliers for determining the performance with other indoor sections.

NOTE: For dry bulb temperatures different than those listed (between 73-87 F), sensible capacity increases by 1060 BTUH per 1000 CFM per degree above the listed temperature and decreases by 1060 BTUH per 1000 CFM per degree below the listed temperature.

Air Handler	Coil	T.C.	S.C.	KW
F6FP060	-	1.01	1.04	1.04
MV20D	FC/MC62D	1.00	1.02	1.03

Variable Speed Furnace	Coil	T.C.	S.C.	KW
T*(8,L)X*C16	FC/MC62D	1.01	1.03	1.00
T*(8,L)X*C20	FC/MC62D	1.01	1.05	1.00
T*9X*C16	FC/MC62D	1.00	1.02	1.01
T*9X*C20	FC/MC62D	1.01	1.03	1.04
T*9X*D20	FC/MC62D	1.01	1.03	1.04
Y*(8,L)(C,V)*C20	FC/MC62D	1.01	1.02	1.04
Y*9(C,V)*C16	FC/MC62D	1.00	1.01	1.06
Y*9(C,V)*C20	FC/MC62D	1.00	1.01	1.04
Y*9(C,V)*D20	FC/MC62D	1.00	1.01	1.03

COOLING PERFORMANCE DATA																
CONDENSING UNIT MODEL NO.		YHJF48S41S1														
INDOOR COIL MODEL NO.		F6FP060														
CONDENSING ENTERING AIR TEMPERATURE	IDCFM	1400					1600					1800				
	ID DB (°F)	80	80	75	80	80	80	80	75	80	80	80	80	75	80	80
	ID WB (°F)	57	62	62	67	72	57	62	62	67	72	57	62	62	67	72
65	T.C.	46.3	48.5	48.5	53.1	57.3	48.0	50.1	49.9	53.5	58.0	49.8	51.6	51.4	53.9	58.7
	S.C.	46.3	42.2	35.8	35.4	29.2	48.0	45.7	38.1	36.7	29.9	49.8	49.3	40.4	38.0	30.6
	KW	2.7	2.7	2.7	2.8	2.7	2.8	2.8	2.8	2.8	2.8	2.9	2.9	2.9	2.9	2.9
75	T.C.	44.4	46.1	46.1	50.7	55.0	46.2	47.4	47.3	51.3	55.8	48.0	48.7	48.5	51.8	56.5
	S.C.	44.4	41.2	34.8	34.4	28.2	46.2	44.2	37.0	36.0	29.0	48.0	47.1	39.2	37.5	29.8
	KW	3.0	3.0	3.0	3.0	3.1	3.1	3.1	3.1	3.1	3.2	3.2	3.2	3.2	3.2	3.2
85	T.C.	42.4	43.6	43.6	48.3	52.7	44.3	44.7	44.7	49.0	53.5	46.2	45.7	45.7	49.8	54.3
	S.C.	42.4	40.2	33.7	33.5	27.1	44.3	42.6	35.8	35.3	28.0	46.2	45.0	38.0	37.0	29.0
	KW	3.3	3.3	3.3	3.3	3.4	3.4	3.4	3.4	3.4	3.5	3.5	3.5	3.5	3.5	3.6
95	T.C.	40.5	41.1	41.2	45.9	50.5	42.5	42.0	42.0	46.8	51.3	44.4	42.8	42.8	47.7	52.1
	S.C.	40.5	39.2	32.7	32.6	26.0	42.5	41.0	34.7	34.6	27.1	44.4	42.8	36.8	36.5	28.2
	KW	3.7	3.7	3.7	3.6	3.8	3.8	3.8	3.8	3.8	3.9	3.9	3.9	3.9	3.9	4.0
105	T.C.	37.9	38.3	37.6	42.7	47.5	39.7	39.5	38.5	43.5	48.2	41.5	40.7	39.3	44.3	48.8
	S.C.	37.9	37.4	31.1	31.4	24.8	39.7	39.1	33.2	33.3	25.9	41.5	40.7	35.3	35.3	26.9
	KW	4.0	4.0	4.0	4.1	4.2	4.2	4.2	4.1	4.2	4.3	4.3	4.3	4.2	4.3	4.4
115	T.C.	35.2	35.5	34.0	39.5	44.6	36.9	37.1	34.9	40.2	45.1	38.7	38.7	35.8	41.0	45.5
	S.C.	35.2	35.5	29.6	30.1	23.6	36.9	37.1	31.7	32.1	24.7	38.7	38.7	33.9	34.1	25.7
	KW	4.4	4.4	4.4	4.6	4.6	4.6	4.6	4.5	4.7	4.7	4.7	4.7	4.6	4.7	4.8
125	T.C.	32.6	32.7	30.4	36.3	41.7	34.2	34.7	31.3	37.0	42.0	35.8	36.6	32.2	37.7	42.3
	S.C.	32.6	32.7	28.0	28.8	22.4	34.2	34.7	30.2	30.9	23.5	35.8	36.6	32.2	32.9	24.5
	KW	4.8	4.8	4.8	5.0	5.1	5.0	5.0	4.9	5.1	5.1	5.1	5.1	5.0	5.2	5.2

NOTE: ALL CAPACITIES INCLUDE INDOOR FAN HEAT AT 1250 BTUH/1000 CFM.

Multipliers for determining the performance with other indoor sections.

NOTE: For dry bulb temperatures different than those listed (between 73-87 F), sensible capacity increases by 1060 BTUH per 1000 CFM per degree above the listed temperature and decreases by 1060 BTUH per 1000 CFM per degree below the listed temperature.

Air Handler	Coil	T.C.	S.C.	KW
AHX60	-	1.00	0.99	1.04
MV20D	FC/MC62D	1.00	1.01	1.04

Variable Speed Furnace	Coil	T.C.	S.C.	KW
T*(8,L)X*C16	FC/MC62D	1.00	1.01	1.08
T*(8,L)X*C20	FC/MC62D	1.00	1.01	1.08
T*9X*C16	FC/MC62D	1.00	1.00	1.08
T*9X*C20	FC/MC62D	1.00	1.01	1.08
T*9X*D20	FC/MC62D	1.00	1.00	1.08
Y*(8,L)(C,V)*C16	FC/MC62D	1.00	1.00	1.08
Y*(8,L)(C,V)*C20	FC/MC62D	1.00	1.00	1.08
Y*9(C,V)*C16	FC/MC62D	0.99	1.00	1.07
Y*9(C,V)*C20	FC/MC62D	0.99	0.99	1.07
Y*9(C,V)*D20	FC/MC62D	0.99	0.99	1.07

COOLING PERFORMANCE DATA - LOW CFM 1-STAGE OPERATION																
CONDENSING UNIT MODEL NO.		YHJF60S41S1														
INDOOR COIL MODEL NO.		AHX60														
CONDENSING ENTERING AIR TEMPERATURE	IDCFM	965					1165					1365				
	ID DB (°F)	80	80	75	80	80	80	80	75	80	80	80	80	75	80	80
	ID WB (°F)	57	62	62	67	72	57	62	62	67	72	57	62	62	67	72
65	T.C.	37.3	41.8	41.6	45.5	50.9	40.4	43.7	43.3	47.7	52.2	43.5	45.6	45.1	49.9	53.6
	S.C.	35.2	32.0	27.8	27.8	23.7	38.1	35.1	30.0	30.0	24.9	41.1	38.2	32.2	32.3	26.1
	KW	2.1	2.1	2.1	2.1	2.1	2.2	2.2	2.2	2.2	2.2	2.3	2.3	2.3	2.3	2.3
75	T.C.	36.2	39.9	39.8	43.6	48.4	39.0	41.6	41.3	45.5	49.8	41.8	43.3	42.8	47.4	51.2
	S.C.	34.2	31.2	27.0	27.0	22.7	36.8	34.3	29.1	29.1	23.9	39.5	37.3	31.3	31.3	25.1
	KW	2.4	2.4	2.4	2.4	2.4	2.5	2.5	2.5	2.5	2.5	2.6	2.6	2.6	2.6	2.6
85	T.C.	35.2	38.0	37.9	41.8	46.0	37.6	39.4	39.2	43.3	47.4	40.1	40.9	40.5	44.8	48.8
	S.C.	33.2	30.5	26.1	26.1	21.7	35.5	33.5	28.3	28.3	22.9	37.8	36.5	30.4	30.4	24.0
	KW	2.7	2.7	2.8	2.7	2.8	2.8	2.8	2.8	2.8	2.8	2.9	2.9	2.9	2.9	2.9
95	T.C.	34.1	36.0	36.0	39.9	43.6	36.2	37.3	37.1	41.1	45.0	38.3	38.5	38.2	42.3	46.5
	S.C.	32.2	29.7	25.3	25.3	20.7	34.2	32.7	27.4	27.4	21.9	36.2	35.7	29.5	29.4	23.0
	KW	3.1	3.1	3.1	3.1	3.1	3.1	3.1	3.1	3.1	3.1	3.2	3.2	3.2	3.2	3.2
105	T.C.	32.4	33.7	33.7	37.3	40.9	34.2	34.7	34.6	38.3	42.1	36.1	35.7	35.5	39.3	43.3
	S.C.	30.6	28.8	24.3	24.3	19.6	32.3	31.1	26.4	26.3	20.8	34.1	33.3	28.5	28.4	22.0
	KW	3.5	3.5	3.5	3.5	3.5	3.5	3.5	3.5	3.5	3.5	3.6	3.6	3.6	3.6	3.6
115	T.C.	30.6	31.4	31.4	34.7	38.3	32.3	32.1	32.1	35.5	39.2	33.9	32.8	32.8	36.3	40.1
	S.C.	28.9	27.8	23.3	23.2	18.6	30.5	29.4	25.4	25.3	19.7	32.0	31.0	27.4	27.3	20.9
	KW	3.9	3.9	3.9	3.9	3.9	3.9	3.9	3.9	3.9	3.9	4.0	4.0	4.0	4.0	4.0
125	T.C.	28.9	29.1	29.1	32.1	35.7	30.3	29.5	29.6	32.7	36.3	31.7	29.9	30.1	33.4	37.0
	S.C.	27.3	26.9	22.4	22.2	17.5	28.6	27.8	24.4	24.2	18.7	30.0	28.6	26.4	26.3	19.9
	KW	4.3	4.3	4.3	4.3	4.3	4.3	4.3	4.3	4.3	4.4	4.4	4.4	4.4	4.4	4.4

NOTE: ALL CAPACITIES INCLUDE INDOOR FAN HEAT AT 1250 BTUH/1000 CFM.

Multipliers for determining the performance with other indoor sections.

NOTE: For dry bulb temperatures different than those listed (between 73-87 F), sensible capacity increases by 1060 BTUH per 1000 CFM per degree above the listed temperature and decreases by 1060 BTUH per 1000 CFM per degree below the listed temperature.

LOW CFM

Air Handler	Coil	T.C.	S.C.	KW
MV20D	FC/MC62D	1.00	1.00	0.99

Variable Speed Furnace	Coil	T.C.	S.C.	KW
T*(8,L)X*C20	FC/MC62D	0.92	0.87	0.97
T*9X*C20	FC/MC62D	1.01	1.02	1.02
T*9X*D20	FC/MC62D	1.02	1.03	1.01
Y*(8,L)(C,V)*C20	FC/MC62D	0.97	0.94	0.99
Y*9(C,V)*C20	FC/MC62D	0.97	0.95	1.00
Y*9(C,V)*D20	FC/MC62D	0.98	0.96	1.01

COOLING PERFORMANCE DATA - HIGH CFM 2-STAGE OPERATION																
CONDENSING UNIT MODEL NO.		YHJF60S41S1														
INDOOR COIL MODEL NO.		AHX60														
CONDENSING ENTERING AIR TEMPERATURE	IDCFM	1650					1850					2050				
	ID DB (°F)	80	80	75	80	80	80	80	75	80	80	80	80	75	80	80
	ID WB (°F)	57	62	62	67	72	57	62	62	67	72	57	62	62	67	72
65	T.C.	56.5	60.0	59.6	65.6	70.6	58.5	61.2	60.8	66.7	72.5	60.5	62.3	62.0	67.8	74.4
	S.C.	55.7	50.3	42.9	42.5	34.9	57.7	53.1	44.9	44.5	36.0	59.6	55.9	47.0	46.5	37.1
	KW	3.4	3.5	3.5	3.5	3.6	3.5	3.6	3.5	3.6	3.7	3.6	3.6	3.6	3.7	3.8
75	T.C.	54.4	57.2	56.8	62.6	67.6	56.3	58.2	57.9	63.6	69.1	58.1	59.2	59.0	64.6	70.6
	S.C.	53.6	49.1	41.6	41.3	33.5	55.4	51.9	43.7	43.2	34.6	57.3	54.7	45.7	45.2	35.7
	KW	3.8	3.9	3.8	3.9	4.0	3.9	3.9	3.9	4.0	4.1	4.0	4.0	4.0	4.1	4.2
85	T.C.	52.3	54.4	54.0	59.6	64.6	54.0	55.2	55.0	60.5	65.8	55.7	56.1	56.0	61.3	66.9
	S.C.	51.5	48.0	40.3	40.1	32.2	53.2	50.7	42.4	42.0	33.2	54.9	53.4	44.4	43.9	34.3
	KW	4.2	4.2	4.2	4.3	4.4	4.3	4.3	4.3	4.4	4.5	4.4	4.4	4.4	4.5	4.6
95	T.C.	50.2	51.6	51.2	56.5	61.7	51.8	52.3	52.1	57.3	62.4	53.3	52.9	53.0	58.1	63.2
	S.C.	49.5	46.8	39.1	38.9	30.8	51.0	49.5	41.1	40.8	31.8	52.5	52.1	43.1	42.6	32.9
	KW	4.6	4.6	4.6	4.7	4.8	4.7	4.7	4.7	4.8	4.9	4.8	4.8	4.8	4.9	5.0
105	T.C.	47.5	48.0	47.8	52.6	57.5	48.8	49.0	48.4	53.3	58.1	50.2	50.0	49.1	54.0	58.8
	S.C.	46.8	45.2	37.6	37.4	29.2	48.1	47.3	39.6	39.2	30.2	49.5	49.3	41.5	41.1	31.3
	KW	5.1	5.1	5.1	5.2	5.3	5.2	5.2	5.2	5.3	5.4	5.3	5.3	5.3	5.4	5.5
115	T.C.	44.7	44.4	44.4	48.7	53.3	45.9	45.7	44.8	49.3	53.9	47.1	47.1	45.2	49.8	54.4
	S.C.	44.1	43.7	36.1	35.8	27.6	45.2	45.0	38.0	37.7	28.6	46.4	46.4	39.9	39.5	29.7
	KW	5.6	5.6	5.6	5.7	5.8	5.7	5.7	5.7	5.8	5.9	5.8	5.8	5.8	5.9	6.0
125	T.C.	42.0	40.7	41.0	44.8	49.2	43.0	42.5	41.1	45.3	49.6	44.0	44.2	41.3	45.7	50.0
	S.C.	41.4	40.7	34.6	34.3	26.0	42.3	42.5	36.5	36.2	27.0	43.3	43.5	38.4	38.0	28.1
	KW	6.1	6.1	6.1	6.2	6.3	6.2	6.2	6.2	6.3	6.4	6.3	6.3	6.3	6.4	6.5

NOTE: ALL CAPACITIES INCLUDE INDOOR FAN HEAT AT 1250 BTUH/1000 CFM.

Multipliers for determining the performance with other indoor sections.

NOTE: For dry bulb temperatures different than those listed (between 73-87 F), sensible capacity increases by 1060 BTUH per 1000 CFM per degree above the listed temperature and decreases by 1060 BTUH per 1000 CFM per degree below the listed temperature.

HIGH CFM

Air Handler	Coil	T.C.	S.C.	KW
MV20D	FC/MC62D	1.03	1.01	0.96

Variable Speed Furnace	Coil	T.C.	S.C.	KW
T*(8,L)X*C20	FC/MC62D	1.02	0.97	0.93
T*9X*C20	FC/MC62D	1.01	0.95	0.93
T*9X*D20	FC/MC62D	1.02	0.97	0.93
Y*(8,L)(C,V)*C20	FC/MC62D	1.01	0.96	0.93
Y*9(C,V)*C20	FC/MC62D	1.01	0.96	0.96
Y*9(C,V)*D20	FC/MC62D	1.01	0.96	0.95

HEATING PERFORMANCE DATA										
CONDENSING UNIT MODEL NO		YHJF18S41S1								
EVAPORATOR COIL MODEL NO		AHX30								
AIR TEMP. ENTERING OUTDOOR UNIT	AIR TEMP. ENTERING INDOOR COIL	ID CFM								
		450			600			750		
		MBTUH	KW	C.O.P.	MBTUH	KW	C.O.P.	MBTUH	KW	C.O.P.
60	60	21.1	4.1	1.3	22.2	4.5	1.2	23.3	4.9	1.1
	70	20.5	3.6	1.5	21.6	4.0	1.4	22.6	4.3	1.3
	80	19.9	3.2	1.6	20.9	3.5	1.5	21.9	3.9	1.4
47	60	18.6	3.8	1.3	19.2	4.0	1.2	19.8	4.2	1.1
	70	17.7	3.3	1.4	18.4	3.5	1.3	19.1	3.7	1.2
	80	16.8	2.8	1.6	17.6	3.1	1.5	18.4	3.3	1.4
40	60	16.7	3.4	1.3	17.3	3.6	1.2	17.9	3.8	1.1
	70	16.1	3.0	1.4	16.8	3.2	1.3	17.4	3.4	1.2
	80	15.6	2.7	1.5	16.3	2.9	1.4	17.0	3.1	1.3
30	60	14.6	3.1	1.2	15.1	3.2	1.2	15.5	3.4	1.1
	70	14.2	2.7	1.4	14.6	2.9	1.3	15.0	3.0	1.2
	80	13.7	2.4	1.5	14.1	2.5	1.4	14.4	2.6	1.3
17	60	11.7	2.6	1.2	12.0	2.6	1.1	12.3	2.7	1.1
	70	11.2	2.2	1.3	11.6	2.3	1.2	11.9	2.4	1.2
	80	10.8	2.0	1.5	11.1	2.0	1.4	11.5	2.1	1.3
10	60	10.1	2.3	1.1	10.3	2.3	1.1	10.4	2.3	1.0
	70	9.6	1.9	1.3	9.9	2.0	1.2	10.2	2.1	1.2
	80	9.1	1.7	1.4	9.5	1.8	1.4	9.9	1.9	1.3

NOTE: ALL CAPACITIES ARE NET (KBTUH) WITH INDOOR FAN HEAT ALREADY DEDUCTED AT 1250 BTUH/1000 CFM.

Multipliers for determining the performance with other indoor sections.

Air Handler	Coil	MBH	KW	COP
AV*36	-	1.00	1.03	0.97
MV12B	FC/MC35B	1.00	0.97	1.03
MV12B	FC/MC43B	1.00	1.01	0.99

Variable Speed Furnace	Coil	MBH	KW	COP
T*(8,L)X*A12	FC/MC/PC32A	0.99	0.99	1.00
Y*(8,L)(C,V)*A12	FC/MC/PC32A	1.00	0.97	1.03
Y*(8,L)(C,V)*B12	FC/MC/PC35B	1.00	0.99	1.01
Y*(8,L)(C,V)*C16	FC/MC/PC35C	1.00	0.98	1.02
Y*9(C,V)*B12	FC/MC/PC35B	1.00	0.98	1.02
Y*9(C,V)*C16	FC/MC/PC35C	1.00	0.99	1.01
Y*(8,L)(C,V)*A12	FC/MC/PC37A	1.00	1.01	0.99
Y*(8,L)(C,V)*B12	FC/MC/PC43B	1.00	0.98	1.02

HEATING PERFORMANCE DATA										
CONDENSING UNIT MODEL NO		YHJF24S41S1								
EVAPORATOR COIL MODEL NO		AHX30								
AIR TEMP. ENTERING OUTDOOR UNIT	AIR TEMP. ENTERING INDOOR COIL	ID CFM								
		600			800			1000		
		MBTUH	KW	C.O.P.	MBTUH	KW	C.O.P.	MBTUH	KW	C.O.P.
60	60	26.8	4.0	1.7	27.6	4.3	1.6	28.4	4.5	1.5
	70	25.1	3.4	1.9	26.1	3.7	1.8	27.2	4.0	1.6
	80	23.3	2.9	2.1	24.7	3.2	2.0	26.1	3.5	1.8
47	60	24.8	3.8	1.7	25.0	4.0	1.5	25.2	4.1	1.4
	70	22.7	3.2	1.8	23.2	3.4	1.7	23.7	3.6	1.6
	80	20.7	2.7	2.0	21.5	2.9	1.9	22.2	3.1	1.8
40	60	20.8	3.3	1.6	21.5	3.5	1.5	22.3	3.7	1.4
	70	19.5	2.9	1.8	20.3	3.0	1.7	21.2	3.2	1.6
	80	18.2	2.4	2.0	19.1	2.6	1.8	20.0	2.8	1.7
30	60	18.7	3.1	1.6	18.8	3.1	1.5	18.9	3.2	1.4
	70	17.5	2.6	1.7	17.8	2.7	1.6	18.1	2.8	1.5
	80	16.2	2.3	1.9	16.8	2.4	1.8	17.3	2.5	1.7
17	60	15.5	2.7	1.5	15.8	2.7	1.4	16.2	2.8	1.4
	70	13.1	2.1	1.6	13.8	2.2	1.6	14.5	2.3	1.5
	80	10.8	1.6	1.8	11.8	1.7	1.7	12.8	1.9	1.6
10	60	13.5	2.4	1.5	13.8	2.4	1.4	14.0	2.4	1.3
	70	12.2	1.9	1.6	12.5	2.0	1.5	12.8	2.0	1.5
	80	10.8	1.6	1.8	11.2	1.7	1.7	11.6	1.7	1.6

NOTE: ALL CAPACITIES ARE NET (KBTUH) WITH INDOOR FAN HEAT ALREADY DEDUCTED AT 1250 BTUH/1000 CFM.

Multipliers for determining the performance with other indoor sections.

Air Handler	Coil	MBH	KW	COP
AHX36	–	1.01	1.02	0.99
AV*36	–	0.99	1.02	0.97
F6FP030	–	1.00	1.00	1.00
F6FP036	–	1.00	1.01	0.99
MV12B	FC/MC35B	1.00	1.01	0.99
MV12B	FC/MC43B	1.00	1.05	0.95

Variable Speed Furnace	Coil	MBH	KW	COP
T*(8,L)X*A12	FC/MC/PC32A	0.99	1.02	0.97
T*(8,L)X*B12	FC/MC/PC35B	0.99	1.03	0.96
T*(8,L)X*C16	FC/MC/PC35C	0.99	1.03	0.96
T*(8,L)X*C20	FC/MC/PC35C	0.99	1.03	0.96
T*9X*B12	FC/MC/PC35B	0.99	1.02	0.97
T*9X*C16	FC/MC/PC35C	0.99	1.04	0.95
T*9X*C20	FC/MC/PC35C	1.00	1.02	0.98
T*(8,L)X*A12	FC/MC/PC37A	1.00	1.07	0.94
T*(8,L)X*B12	FC/MC/PC43B	0.99	1.07	0.93

Variable Speed Furnace	Coil	MBH	KW	COP
T*(8,L)X*C16	FC/MC/PC43C	0.99	1.07	0.93
T*9X*B12	FC/MC/PC43B	1.00	1.07	0.94
T*9X*C16	FC/MC/PC43C	0.99	1.04	0.95
T*9X*C20	FC/MC/PC43C	0.99	1.03	0.96
Y*(8,L)(C,V)*A12	FC/MC/PC32A	1.00	0.99	1.01
Y*(8,L)(C,V)*B12	FC/MC/PC35B	0.99	0.98	1.01
Y*(8,L)(C,V)*C16	FC/MC/PC35C	1.00	1.01	0.99
Y*(8,L)(C,V)*C20	FC/MC/PC35C	0.98	0.99	0.99
Y*9(C,V)*B12	FC/MC/PC35B	1.00	1.00	1.00
Y*9(C,V)*C16	FC/MC/PC35C	1.00	1.02	0.98
Y*9(C,V)*C20	FC/MC/PC35C	0.99	0.98	1.01
Y*(8,L)(C,V)*A12	FC/MC/PC37A	1.01	1.03	0.98
Y*(8,L)(C,V)*B12	FC/MC/PC43B	0.99	1.01	0.98
Y*(8,L)(C,V)*C16	FC/MC/PC43C	1.00	1.05	0.95
Y*(8,L)(C,V)*C20	FC/MC/PC43C	0.99	1.02	0.97
Y*9(C,V)*B12	FC/MC/PC43B	1.00	1.04	0.96
Y*9(C,V)*C16	FC/MC/PC43C	1.00	1.05	0.95
Y*9(C,V)*C20	FC/MC/PC43C	1.01	1.05	0.96

HEATING PERFORMANCE DATA										
CONDENSING UNIT MODEL NO		YHJF30S41S1								
EVAPORATOR COIL MODEL NO		AHX36								
AIR TEMP. ENTERING OUTDOOR UNIT	AIR TEMP. ENTERING INDOOR COIL	ID CFM								
		800			1000			1200		
		MBTUH	KW	C.O.P.	MBTUH	KW	C.O.P.	MBTUH	KW	C.O.P.
60	60	36.9	4.6	2.1	37.4	4.8	1.9	38.0	5.0	1.8
	70	35.9	4.0	2.3	36.5	4.2	2.2	37.1	4.4	2.0
	80	34.8	3.5	2.6	35.5	3.8	2.4	36.2	4.0	2.2
47	60	31.3	4.1	2.0	31.8	4.2	1.8	32.3	4.4	1.7
	70	30.5	3.6	2.2	31.0	3.7	2.1	31.5	3.9	1.9
	80	29.8	3.1	2.5	30.2	3.3	2.3	30.7	3.5	2.2
40	60	28.4	3.7	1.9	28.9	3.9	1.8	29.3	4.0	1.7
	70	27.6	3.3	2.2	28.1	3.4	2.0	28.6	3.6	1.9
	80	26.8	2.9	2.4	27.4	3.0	2.3	27.9	3.2	2.1
30	60	24.8	3.3	1.9	25.1	3.4	1.8	25.4	3.5	1.7
	70	23.9	2.9	2.1	24.3	3.0	2.0	24.6	3.1	1.9
	80	23.0	2.6	2.3	23.4	2.7	2.2	23.8	2.7	2.1
17	60	19.9	2.8	1.8	20.1	2.8	1.7	20.4	2.9	1.7
	70	18.8	2.4	2.0	19.2	2.4	2.0	19.6	2.5	1.9
	80	17.8	2.0	2.3	18.3	2.1	2.2	18.8	2.2	2.1
10	60	17.1	2.4	1.8	17.4	2.4	1.7	17.6	2.5	1.6
	70	15.8	2.0	2.0	16.3	2.1	1.9	16.7	2.1	1.8
	80	14.4	1.7	2.2	15.1	1.8	2.1	15.8	1.9	2.0

NOTE: ALL CAPACITIES ARE NET (KBTUH) WITH INDOOR FAN HEAT ALREADY DEDUCTED AT 1250 BTUH/1000 CFM.

Multipliers for determining the performance with other indoor sections.

Air Handler	Coil	MBH	KW	COP
AV*36	-	0.99	1.00	1.00
F6FP042	-	0.99	1.00	1.00
MV12B	FC/MC43B	1.00	0.97	1.03
MV16C	FC/MC43C	1.00	0.98	1.02

Variable Speed Furnace	Coil	MBH	KW	COP
T*(8,L)X*A12	FC/MC/PC37A	1.00	1.01	1.00
T*(8,L)X*B12	FC/MC/PC43B	1.00	1.00	1.00
T*(8,L)X*C16	FC/MC/PC43C	1.00	0.99	1.01
T*9X*B12	FC/MC/PC43B	1.00	1.00	1.01
T*9X*C16	FC/MC/PC43C	1.00	0.99	1.01
Y*(8,L)(C,V)*A12	FC/MC/PC37A	1.00	0.95	1.05
Y*(8,L)(C,V)*B12	FC/MC/PC43B	1.00	0.97	1.04
Y*(8,L)(C,V)*C16	FC/MC/PC43C	1.00	0.98	1.02
Y*(8,L)(C,V)*C20	FC/MC/PC43C	1.00	0.99	1.02
Y*9(C,V)*B12	FC/MC/PC43B	1.00	0.96	1.04
Y*9(C,V)*C16	FC/MC/PC43C	1.00	0.98	1.03
Y*9(C,V)*C20	FC/MC/PC43C	1.00	0.98	1.03

HEATING PERFORMANCE DATA										
CONDENSING UNIT MODEL NO		YHJF36S41S1								
EVAPORATOR COIL MODEL NO		AHX36								
AIR TEMP. ENTERING OUTDOOR UNIT	AIR TEMP. ENTERING INDOOR COIL	ID CFM								
		1000			1200			1400		
		MBTUH	KW	C.O.P.	MBTUH	KW	C.O.P.	MBTUH	KW	C.O.P.
60	60	47.2	4.2	2.9	47.9	4.4	2.7	48.6	4.6	2.6
	70	46.3	3.7	3.3	46.8	3.9	3.1	47.3	4.1	2.9
	80	45.3	3.3	3.7	45.6	3.4	3.4	46.0	3.6	3.2
47	60	40.0	3.7	2.8	40.4	3.8	2.7	40.9	4.0	2.5
	70	39.5	3.3	3.2	39.8	3.4	3.0	40.1	3.5	2.8
	80	38.9	2.9	3.5	39.2	3.0	3.3	39.4	3.2	3.2
40	60	36.8	3.5	2.7	37.0	3.6	2.6	37.2	3.7	2.5
	70	36.3	3.1	3.1	36.4	3.2	2.9	36.6	3.3	2.8
	80	35.7	2.7	3.5	35.9	2.8	3.3	36.0	2.9	3.1
30	60	31.9	3.1	2.7	32.0	3.1	2.5	32.1	3.2	2.4
	70	31.5	2.7	3.1	31.6	2.8	2.9	31.7	2.9	2.7
	80	31.0	2.4	3.4	31.2	2.5	3.2	31.4	2.6	3.1
17	60	25.3	2.6	2.5	25.4	2.6	2.4	25.4	2.6	2.3
	70	24.2	2.2	2.9	24.7	2.3	2.8	25.2	2.3	2.6
	80	23.1	1.9	3.2	24.1	2.0	3.1	25.0	2.1	3.0
10	60	21.6	2.3	2.3	20.9	2.3	2.3	20.2	2.2	2.2
	70	21.4	2.0	2.7	20.3	2.0	2.6	19.2	1.9	2.5
	80	21.1	1.8	3.1	19.6	1.7	2.9	18.2	1.6	2.7

NOTE: ALL CAPACITIES ARE NET (KBTUH) WITH INDOOR FAN HEAT ALREADY DEDUCTED AT 1250 BTUH/1000 CFM.

Multipliers for determining the performance with other indoor sections.

Air Handler	Coil	MBH	KW	COP
AHX42	—	1.00	1.01	0.99
AV*36	—	1.00	0.99	1.01
F6FP042	—	1.00	1.02	0.98
MV12B	FC/MC43B	1.00	0.98	1.02
MV16C	FC/MC43C	1.00	0.98	1.02

Variable Speed Furnace	Coil	MBH	KW	COP
T*(8,L)X*A12	FC/MC/PC37A	1.00	1.00	1.00
T*(8,L)X*B12	FC/MC/PC43B	1.00	1.00	1.00
T*(8,L)X*C16	FC/MC/PC43C	1.00	0.99	1.01
T*(8,L)X*C20	FC/MC/PC43C	1.00	1.02	0.98
T*9X*B12	FC/MC/PC43B	1.00	1.00	1.00
T*9X*C16	FC/MC/PC43C	1.00	1.01	0.99
T*9X*C20	FC/MC/PC43C	1.00	0.98	1.02
Y*(8,L)(C,V)*C16	FC/MC/PC43C	1.00	0.98	1.02
Y*(8,L)(C,V)*C20	FC/MC/PC43C	1.00	0.98	1.02
Y*9(C,V)*C16	FC/MC/PC43C	1.00	0.99	1.01
Y*9(C,V)*C20	FC/MC/PC43C	1.00	0.97	1.03

HEATING PERFORMANCE DATA										
CONDENSING UNIT MODEL NO		YHJF42S41S1								
EVAPORATOR COIL MODEL NO		AHX60								
AIR TEMP. ENTERING OUTDOOR UNIT	AIR TEMP. ENTERING INDOOR COIL	ID CFM								
		1200			1400			1600		
		MBTUH	KW	C.O.P.	MBTUH	KW	C.O.P.	MBTUH	KW	C.O.P.
60	60	45.3	4.1	2.8	45.0	4.1	2.7	44.6	4.2	2.6
	70	45.1	3.8	3.0	44.9	3.8	2.9	44.6	3.9	2.8
	80	44.9	3.5	3.3	44.8	3.6	3.1	44.7	3.6	3.0
47	60	41.3	4.1	2.5	41.2	4.1	2.5	41.1	4.1	2.4
	70	40.7	3.6	2.8	40.7	3.7	2.7	40.7	3.7	2.6
	80	40.0	3.3	3.1	40.2	3.3	3.0	40.3	3.4	2.9
40	60	38.2	3.8	2.5	38.4	3.9	2.4	38.5	3.9	2.3
	70	37.4	3.4	2.8	37.7	3.5	2.7	38.1	3.5	2.6
	80	36.6	3.1	3.0	37.1	3.1	3.0	37.7	3.2	2.9
30	60	33.3	3.4	2.4	33.4	3.4	2.4	33.5	3.4	2.3
	70	32.7	3.0	2.7	32.8	3.1	2.6	32.9	3.1	2.5
	80	32.0	2.7	3.0	32.2	2.8	2.9	32.3	2.8	2.8
17	60	26.7	2.9	2.2	26.9	2.9	2.2	27.2	2.8	2.2
	70	25.2	2.5	2.5	20.9	2.5	2.4	26.7	2.5	2.5
	80	23.6	2.1	2.8	14.9	2.2	2.7	26.3	2.3	2.7
10	60	22.8	2.5	2.3	23.3	2.5	2.2	23.8	2.5	2.2
	70	22.9	2.2	2.6	23.2	2.3	2.5	23.6	2.3	2.4
	80	22.9	2.1	2.8	23.1	2.1	2.8	23.3	2.1	2.7

NOTE: ALL CAPACITIES ARE NET (KBTUH) WITH INDOOR FAN HEAT ALREADY DEDUCTED AT 1250 BTUH/1000 CFM.

Multipliers for determining the performance with other indoor sections.

Air Handler	Coil	MBH	KW	COP
F6FP060	-	1.01	1.01	1.00
MV20D	FC/MC62D	1.00	1.01	1.00

Variable Speed Furnace	Coil	MBH	KW	COP
T*(8,L)X*C16	FC/MC62D	1.00	1.02	0.99
T*(8,L)X*C20	FC/MC62D	1.01	1.02	0.99
T*9X*C16	FC/MC62D	1.01	1.00	1.02
T*9X*C20	FC/MC62D	1.00	1.01	1.00
T*9X*D20	FC/MC62D	1.00	1.01	1.00
Y*(8,L)(C,V)*C20	FC/MC62D	1.01	1.00	1.01
Y*9(C,V)*C16	FC/MC62D	1.02	0.97	1.06
Y*9(C,V)*C20	FC/MC62D	1.01	0.98	1.04
Y*9(C,V)*D20	FC/MC62D	1.01	0.99	1.03

HEATING PERFORMANCE DATA										
CONDENSING UNIT MODEL NO		YHJF48S41S1								
EVAPORATOR COIL MODEL NO		F6FP060								
AIR TEMP. ENTERING OUTDOOR UNIT	AIR TEMP. ENTERING INDOOR COIL	ID CFM								
		1400			1600			1800		
		MBTUH	KW	C.O.P.	MBTUH	KW	C.O.P.	MBTUH	KW	C.O.P.
60	60	62.2	4.3	3.7	62.7	4.5	3.5	63.2	4.6	3.3
	70	60.9	3.8	4.2	61.2	3.9	4.0	61.6	4.1	3.8
	80	59.5	3.3	4.8	59.8	3.5	4.5	60.0	3.6	4.2
47	60	53.1	3.6	3.8	53.1	3.7	3.6	53.1	3.8	3.4
	70	52.0	3.2	4.3	52.0	3.2	4.1	52.1	3.3	3.9
	80	50.9	2.8	4.8	51.0	2.9	4.6	51.0	2.9	4.5
40	60	47.9	3.2	3.8	47.8	3.3	3.6	47.8	3.4	3.4
	70	47.2	2.8	4.4	47.0	2.9	4.2	46.9	3.0	3.9
	80	46.5	2.5	5.0	46.2	2.6	4.7	45.9	2.6	4.4
30	60	40.1	2.9	3.6	40.2	2.9	3.5	40.3	2.9	3.3
	70	38.9	2.7	3.8	39.3	2.7	3.8	39.6	2.6	3.7
	80	37.8	2.5	4.0	38.3	2.4	4.0	38.8	2.4	4.1
17	60	30.2	2.6	2.8	31.3	2.8	2.8	32.4	2.9	2.7
	70	28.7	2.4	3.0	29.5	2.4	3.0	30.3	2.5	2.9
	80	27.3	2.2	3.2	27.7	2.2	3.2	28.1	2.2	3.1
10	60	25.2	2.4	2.6	24.8	2.3	2.5	24.4	2.3	2.5
	70	24.5	2.1	2.9	25.3	2.1	3.0	26.1	2.0	3.2
	80	23.8	1.9	3.1	25.7	1.8	3.5	27.7	1.8	3.9

NOTE: ALL CAPACITIES ARE NET (KBTUH) WITH INDOOR FAN HEAT ALREADY DEDUCTED AT 1250 BTUH/1000 CFM.

Multipliers for determining the performance with other indoor sections.

Air Handler	Coil	MBH	KW	COP
AHX60	-	1.00	0.99	1.01
MV20D	FC/MC62D	1.00	0.99	1.01

Variable Speed Furnace	Coil	MBH	KW	COP
T*(8,L)X*C16	FC/MC62D	1.00	0.98	1.02
T*(8,L)X*C20	FC/MC62D	1.00	0.99	1.01
T*9X*C16	FC/MC62D	1.00	0.98	1.02
T*9X*C20	FC/MC62D	1.00	0.99	1.01
T*9X*D20	FC/MC62D	1.00	0.98	1.02
Y*(8,L)(C,V)*C16	FC/MC62D	1.00	0.98	1.02
Y*(8,L)(C,V)*C20	FC/MC62D	1.00	0.98	1.02
Y*9(C,V)*C16	FC/MC62D	1.00	0.97	1.03
Y*9(C,V)*C20	FC/MC62D	1.00	0.96	1.04
Y*9(C,V)*D20	FC/MC62D	1.00	0.97	1.03

HEATING PERFORMANCE DATA										
CONDENSING UNIT MODEL NO		YHJF60S41S1								
EVAPORATOR COIL MODEL NO		AHX60								
AIR TEMP. ENTERING OUTDOOR UNIT	AIR TEMP. ENTERING INDOOR COIL	ID CFM								
		1600			1800			2000		
		MBTUH	KW	C.O.P.	MBTUH	KW	C.O.P.	MBTUH	KW	C.O.P.
60	60	70.70	4.28	4.25	71.76	4.41	4.11	72.83	4.54	3.97
	70	69.78	3.85	4.72	70.63	3.95	4.57	71.49	4.07	4.41
	80	68.86	3.48	5.19	69.51	3.58	5.03	70.15	3.67	4.86
47	60	61.77	3.89	4.05	62.15	3.97	3.92	62.54	4.05	3.78
	70	60.84	3.47	4.53	61.18	3.55	4.39	61.52	3.62	4.23
	80	59.90	3.13	5.01	60.20	3.19	4.86	60.50	3.27	4.69
40	60	56.20	3.64	3.93	56.47	3.70	3.80	56.74	3.76	3.69
	70	55.47	3.24	4.42	55.62	3.30	4.27	55.76	3.35	4.13
	80	54.75	2.92	4.90	54.77	2.96	4.75	54.79	3.02	4.57
30	60	49.33	3.30	3.78	49.52	3.33	3.70	49.72	3.34	3.61
	70	47.84	2.83	4.36	47.68	2.87	4.21	47.52	2.90	4.06
	80	46.36	2.45	4.94	45.84	2.49	4.71	45.31	2.53	4.51
17	60	40.18	2.78	3.64	37.45	2.80	3.50	34.72	2.80	3.40
	70	40.02	2.47	4.14	38.68	2.60	4.00	37.36	2.50	3.91
	80	39.86	2.23	4.65	39.91	2.25	4.53	39.99	2.27	4.42
10	60	35.02	2.49	3.52	35.29	2.51	3.45	35.54	2.53	3.38
	70	33.76	2.16	3.98	34.56	2.22	3.90	35.35	2.27	3.82
	80	32.50	1.89	4.44	33.83	1.97	4.34	35.15	2.06	4.26

NOTE: ALL CAPACITIES ARE NET (KBTUH) WITH INDOOR FAN HEAT ALREADY DEDUCTED AT 1250 BTUH/1000 CFM.

Multipliers for determining the performance with other indoor sections.

Air Handler	Coil	MBH	KW	COP
MV20D	FC/MC62D	0.99	1.00	0.99

Variable Speed Furnace	Coil	MBH	KW	COP
T*(8,L)X*C20	FC/MC62D	0.97	0.89	1.10
T*9X*C20	FC/MC62D	1.00	1.01	1.00
T*9X*D20	FC/MC62D	1.00	1.02	0.99
Y*(8,L)(C,V)*C20	FC/MC62D	0.99	0.95	1.04
Y*9(C,V)*C20	FC/MC62D	0.99	0.96	1.04
Y*9(C,V)*D20	FC/MC62D	1.00	0.97	1.03