



PT1520MU
Touchscreen LCD Monitor

USER'S GUIDE

www.planar.com

The information contained in this document is subject to change without notice.
This document contains proprietary information that is protected by copyright. All rights are reserved. No part of this document may be reproduced, translated to another language or stored in a retrieval system, or transmitted by any means, electronic, mechanical, photocopying, recording, or otherwise, without prior written permission. Windows is a registered trademark of Microsoft, Inc.
Other brand or product names are trademarks of their respective holders.

Important Recycle Instructions:

 LCD Lamp(s) inside this product contain mercury. This product may contain other electronic waste that can be hazardous if not disposed of properly. Recycle or dispose in accordance with local, state, or federal Laws. For more information, contact the Electronic Industries Alliance at WWW.EIAE.ORG. For lamp specific disposal information check WWW.LAMPRECYCLE.ORG.

Table of Contents

Usage Notice

<i>Precautions</i>	2
--------------------------	---

Introduction

<i>About Planar's PT1520MU</i>	3
<i>Touch Screen for PT1520MU</i>	4
<i>Package Overview</i>	5

Installation

<i>Product Overview</i>	6
<i>VESA Mount</i>	8
<i>Removing the Deskstand</i>	8
<i>Cable Management</i>	9
<i>Start Your Installation</i>	10

User Controls

<i>Front Panel Controls</i>	12
<i>How to Use the OSD Menus</i>	13
<i>On-Screen Display Menus</i>	14

Appendices

<i>Troubleshooting</i>	15
<i>Warning Signal</i>	16
<i>Product Dimensions</i>	17
<i>Compatibility Modes</i>	18
<i>Touch Screen Driver Installation</i>	19

Usage Notice

 **Warning-** To prevent the risk of fire or shock hazards, do not expose this product to rain or moisture.

 **Warning-** Please do not open or disassemble the product as this may cause electric shock.

Precautions

Follow all warnings, precautions and maintenance as recommended in this user's manual to maximize the life of your unit.

Do:

- Turn off the product before cleaning.
- Touch screen surface may be cleaned using a soft clean cloth moistened with mild window glass commercial cleaners or 50/50 mixture of water and isopropyl alcohol.
- Use a soft cloth moistened with mild detergent to clean the display housing.
- Use only high quality safety approved AC/DC power adapter that comes with your monitor.
- Disconnect the power plug from the AC outlet if the product is not going to be used for an extended period of time.

Don't:

- Do not touch the LCD Display screen surface with sharp or hard objects.
- Do not use abrasive cleaners, waxes or solvents for cleaning.
- Do not operate the product under the following conditions:
 - Extremely hot, cold or humid environment.
 - Areas susceptible to excessive dust and dirt.
 - Near any appliance generating a strong magnetic field.
 - In direct sunlight.

Introduction

About Planar's PT1520MU

The PT1520MU is a 15" flat panel screen with an active matrix, thin-film transistor (TFT) liquid crystal display (LCD).

Features include:

- ❑ Direct analog signal input
- ❑ Active matrix TFT LCD technology
- ❑ 1024x768 XGA resolution
- ❑ 15" viewable display area
- ❑ 31.5 ~ 60 kHz horizontal scan
- ❑ 56 ~ 75 Hz refresh rate
- ❑ Auto -adjustment function
- ❑ Multilingual OSD user controls
- ❑ VESA DPMS power saving
- ❑ Kensington security slot
- ❑ Built-in speakers for multimedia application
- ❑ 75 mm VESA mount
- ❑ Removable base for flexible mounting solutions
- ❑ 3m® 5-wire Resistive touch screen

Touch Screen for PT1520MU

- ❑ 3m® 5-wire Resistive touch screen for finger and stylus input
 - ❑ Surface: Anti-glare treatment
 - ❑ Interface: USB
 - ❑ Durability: 35 million touches at a single point
 - ❑ Hardness of surface: 4H per ASTM D3363-92
 - ❑ Operating force: Stylus- <25 g (average)
Finger - <50 g (average)
 - ❑ Transmissivity: 83% (Typ.) \pm 2%
 - ❑ Haze: 5% (Typ.)
- Driver: 3m® MT 7.11. Supports Microsoft Windows® 2000, XP

Package Overview

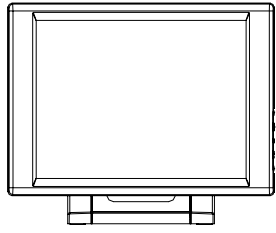

LCD Display

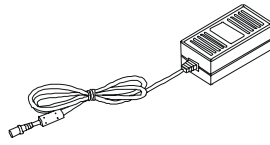

Power Adapter

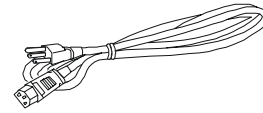

Power Cord

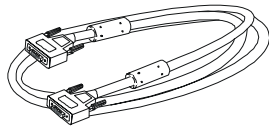

VGA Signal Cable



Audio-in Cable

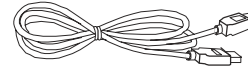

USB Cable



User's Guide



Landing Strip

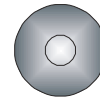

Touchscreen Driver
Installation CD-ROM

Installation

Product Overview

◆ Front View

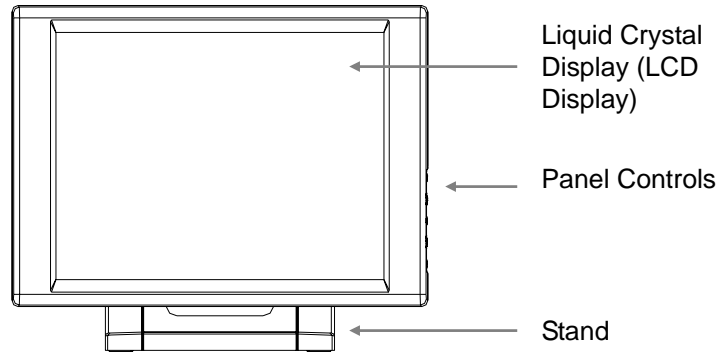

◆ Back View

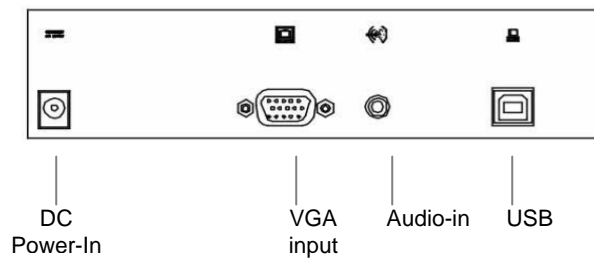
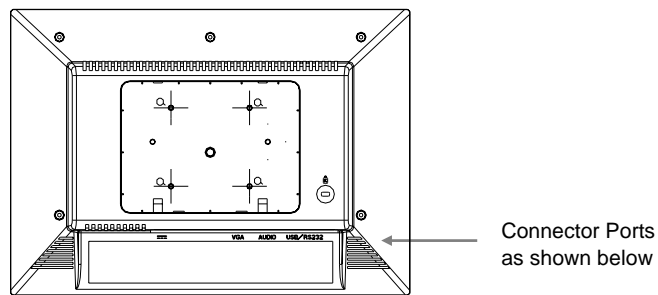

◆ Tilt

Turn the knob. Once loosened, grasp the LCD display with both hands to adjust the tilt as desired. Tighten the knob once the display is in the desired location.

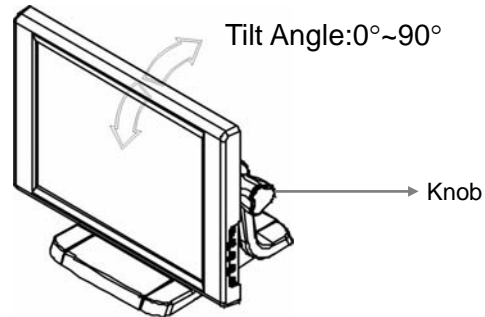

◆ Kensington® Security Slot

The monitor can be secured to your desk or any other fixed object with Kensington lock security products. The Kensington lock is not included.

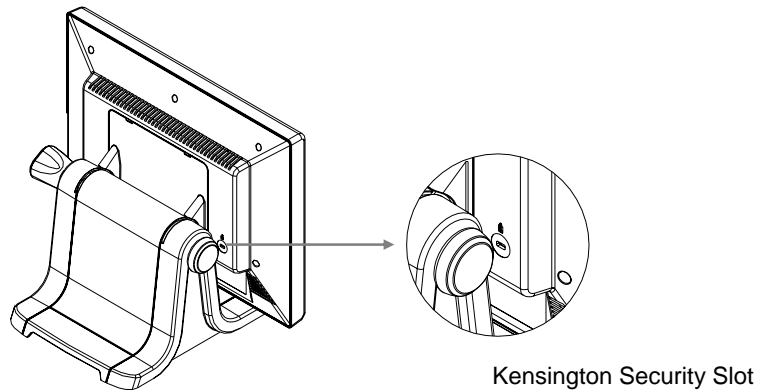

This monitor conforms to the VESA Flat Panel Mounting Physical Mounting Interface Standard which defines a physical mounting interface for flat panel monitors, and corresponding standards for flat panel monitor mounting devices, such as wall and table arms. The VESA mounting interface is located on the back of your monitor.

The 75 mm VESA hole pattern is located inside the rear cover (shown in the following figure).

To mount the monitor on a swing arm or other mounting fixture, follow the instructions included with the mounting fixture to be used.

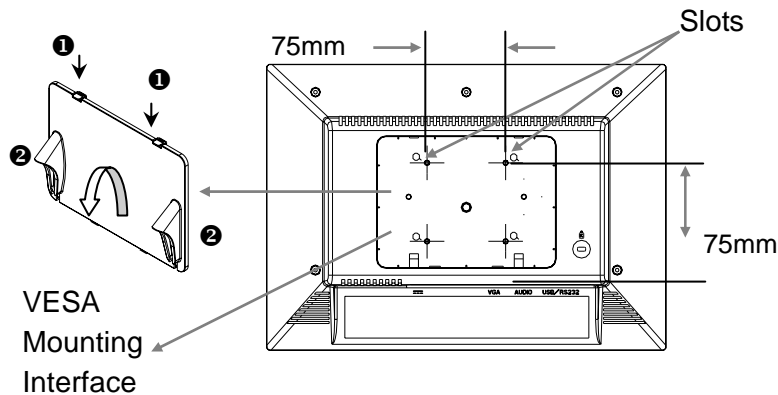

Removing the Deskstand

1. Push clips down (❶) and pull the VESA cover from the rear of the display by the ears (❷). You may need a screw driver or some other item to help you dislodge and prop the first clip while you dislodge the second clip.
2. Unscrew the 4 screws from the rear cover using a Philips screw driver.

Warning!

Please select the proper screws!

The correct screw type to use is M4 x 12.

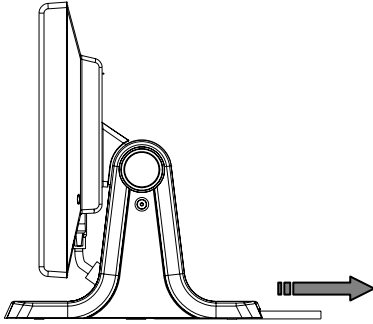

1. Pull all the cables backward while the tilt angle is 0°.

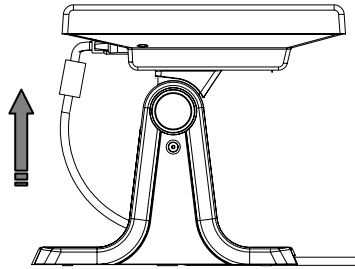

2. Pull all the cables forward while the tilt angle is 90°.

Start Your Installation

◆ Connecting the Display (Figure 10.1)

To setup this display, please refer to the following figure and procedures.

1. Be sure all equipment is turned off.
2. Connect the DC power cord to the power connector; plug one end of the AC power cord into the power adapter, and the other end into an electrical outlet (❶).
3. Connect the VGA signal cable from display VGA input connector to the 15-pin connector of your host computer and tighten the screws (❷).
4. Connect the Audio-In cable from audio input port of your display to the Audio-out port of your computer (❸).
5. Connect the USB cable from USB port of your display to the USB port of your computer (❹).
6. Configure the touch screen. Refer to the “Touch Screen Driver Installation” section on page 19.
7. Once the touch screen is configured, turn on your computer, display and video source.

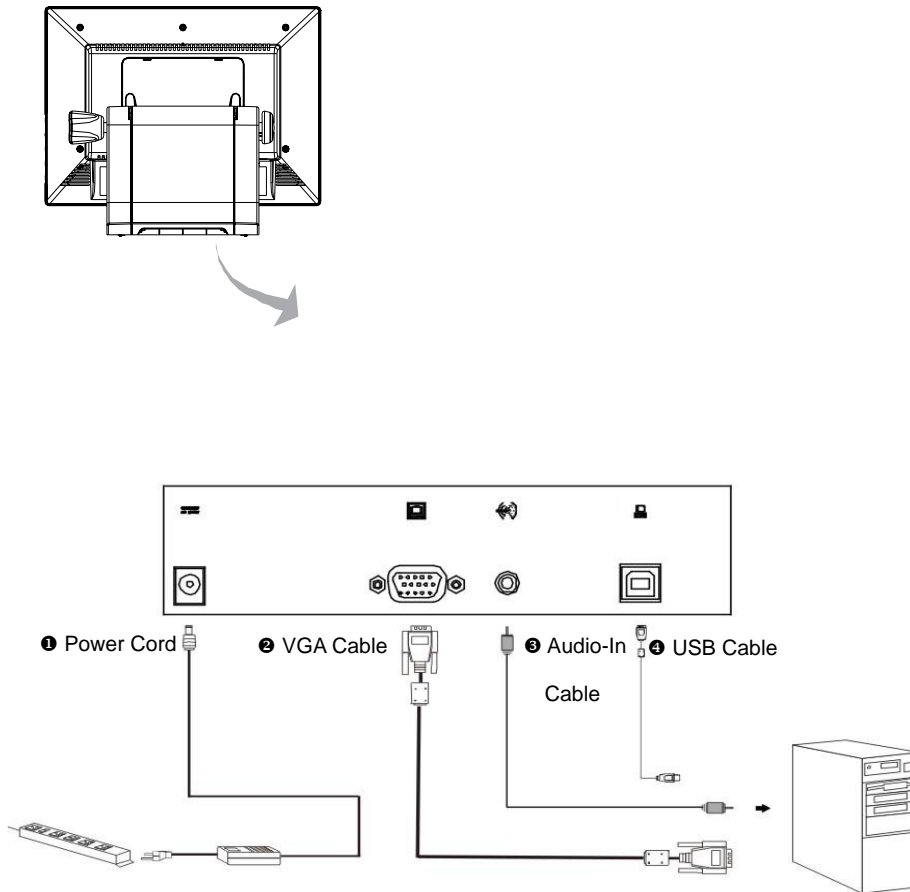

Notice: To ensure the LCD display will work well with your computer, please configure the display mode of your graphics card to make it less than or equal to 1024 x 768 resolution and make sure the timing of the display mode is compatible with the LCD screen. We have listed the “Compatibility Modes” of this LCD screen in appendices for your reference.

Figure 10.1

User Controls

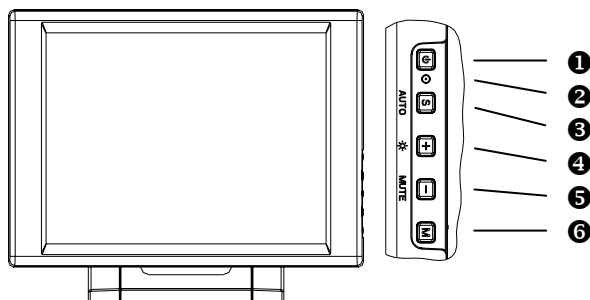
Front Panel Controls



No / Icon	Control	Function
① 	Power Switch	Turns on/ off the power of the LCD display.
②	Power LED	1. Green indicates the display is turned on. 2. Amber indicates the display is in power-saving mode.
③ S	Select/Auto	<i>Select</i> - To select the adjustment items from OSD menus. <i>Auto</i> - To activate the "Auto Adjustment" function to obtain an optimum image.
④ 	Plus/Brightness	1. Increases the brightness of the display image. 2. Increases value of the adjustment functions.
⑤ 	Minus/Mute On/Off	1. Decreases value of the adjustment functions. 2. Makes the volume function ineffective/effective.
⑥ M	Menu Button	Display the OSD menus.

How to Use the OSD Menu

1. Press the "MENU" button to pop up the "on-screen menu" and to select among the four main menus.
2. Choose the adjustment items by pressing the "Select/Auto" button.
3. Adjust the value of the adjustment items by pressing the "+" or "-" button.
4. The OSD menu will automatically close if you have left it idle for a pre-set amount of time.
5. To disable the OSD menu buttons, please follow the instructions below. **Please note:** the monitor has to be ON with a valid signal present.
 - a. Press and hold the "-" key.
 - b. With the "-" key held down, press and hold the "Menu" key for 3 seconds.
 - c. The wording "OSD Locked" will appear for 3 seconds on the monitor. This indicates that all the front buttons, with the exception of the power button, are now disabled.
6. To enable the OSD menu buttons, please follow the instructions below. **Please note:** the monitor has to be ON with a valid signal present.
 - a. Press and hold the "-" key.
 - b. With the "-" key held down, press and hold the "Menu" key for 3 seconds.
 - c. The wording "OSD Unlocked" will appear for 3 seconds on the monitor. This indicates that all the front buttons are now enabled

On-Screen Display Menus

Main Menu	Menu Level 2	Function Description	Remark
Page 1	Auto-Adjustment	Choose this function to obtain an optimum image.	
	Contrast	Adjusts the contrast of the display image. The range is 0~100.	Default is 50
	Brightness	Adjusts the brightness of the image. The range is 0~100.	Default is 70
	Horizontal Position	Changes the horizontal position of the image.	
	Vertical Position	Changes the vertical position of the image.	
	Clock	Changes the displays data frequency to match the frequency of your graphics card. When you experience a vertical flickering bar, use this function to make an adjustment.	
	Phase	Synchronizes the signal timing of the display to that of the graphics card. When you experience an unstable flickering image, use this function to make an adjustment.	
Page 2	Display Mode	Select this function to show the display resolution, vertical refresh, and horizontal scan of the current mode.	
	OSD Off-Time	Adjusts how long the OSD menu will be displayed after inactivity. The range is 5~60.	Default is 30
	Language	Opens the Language sub-menu where you can select the desired language of the OSD. Choices include: English, German, Spanish, French, Japanese, Italian.	Default is English
	Sharpness	Adjusts the sharpness of the image.	
	Reset	Resets the display parameters back to its factory default settings.	
Page 3	Volume	Adjusts the sound volume. The range is 0~32.	Default is 20
	Mute	Disables the sound immediately.	
Page 4	Color Setting	Adjusts and customizes color.	
	Color Adjustment-Red	Adjusts the red color of the display. The range is 0~100.	Default is 100
	Color Adjustment-Green	Adjusts the green color of the display. The range is 0~100.	Default is 100
	Color Adjustment-Blue	Adjusts the blue color of the display. The range is 0~100.	Default is 100

Appendix

Troubleshooting

If you are experiencing trouble with the LCD display, refer to the following. If the problem persists, please contact Planar.

Problem: No image appears on screen.

- ▶ Check that all the I/O and power connectors are correctly installed and well connected as described in the "Installation" section.
- ▶ Make sure the pins of the connectors are not crooked or broken.
- ▶ Reconfigure the resolution of your computer to make it less than or equal to 1024 x 768.

Problem: Partial Image or incorrectly displayed the image.

- ▶ Check to see if the resolution of your computer is higher than that of the LCD display.
- ▶ Reconfigure the resolution of your computer to make it less than or equal to 1024 x 768.

Problem: Image has vertical flickering line bars.

- ▶ Use "Clock" to make an adjustment.
- ▶ Check and reconfigure the display mode of the vertical refresh rate of your graphic card to make it compatible with the LCD display.

Problem: Image is unstable and flickering

- ▶ Use "Phase" to make an adjustment.

Problem: Image is scrolling

- ▶ Check and make sure the VGA signal cable (or adapter) is well connected.
- ▶ Check and reconfigure the display mode of the vertical refresh rate of your graphics card to make it compatible with the LCD Display.

Problem: Ghosting image (character and graphic images)

- ▶ Use "Clock" to make an adjustment. If this problem still exists, use "Phase" to make an adjustment.

Warning Signal

If you see warning messages on your LCD screen, this means that the LCD display cannot receive a clean signal from the computer graphics card.

There are three kinds of sources for this problem. Please check the cable connections or contact Planar for more information.

▶ **No Signal**

This message means that the LCD Display has been powered on but it cannot receive any signal from the computer graphics card. Check all the power switches, power cables, and VGA signal cable.

▶ **Going to Sleep**

This message means that the LCD display is under the power saving mode. In addition, the LCD display will enter the sleeping mode when experiencing a sudden signal disconnecting problem.

▶ **Unsupported Mode**

This message means that the signal of the computer graphics card is not compatible with the LCD display. The LCD display will show this message when the signal is not included in the compatibility mode listed in the Appendices of this manual.

Product Dimensions

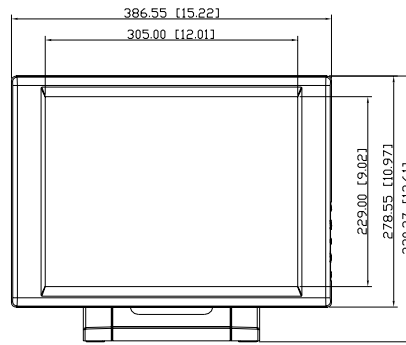

Front View

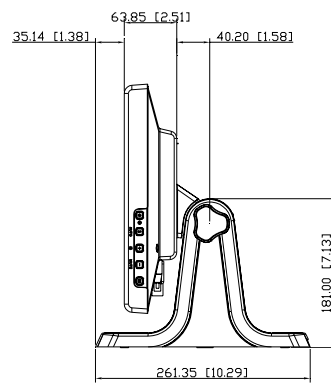

Side View

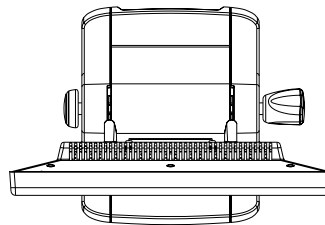

Top View

Compatibility Modes

Mode	Resolution	V. Frequency (Hz)	H. Frequency (kHz)
IBM VGA	640 x 350	70	31.5
IBM VGA	640 x 400	70	31.5
IBM VGA	720 x 400	70	31.5
IBM VGA	640 x 480	60	31.5
VESA VGA	640 x 480	72	37.9
VESA VGA	640 x 480	75	37.5
VESA SVGA	800 x 600	56	35.2
VESA SVGA	800 x 600	60	37.9
VESA SVGA	800 x 600	72	48.1
VESA SVGA	800 x 600	75	46.9
VESA XGA	1024 x 768	60	48.4
VESA XGA	1024 x 768	70	56.5
VESA XGA	1024 x 768	75	60.0
Apple Mac LC	640 x 480	67	34.9
Apple Mac II	640 x 480	67	35.0
Apple Mac	832 x 624	75	49.7
Apple Mac	1024 x 768	75	60.2

Touch Screen Driver Installation

Please note: the PT1520MU is Microsoft Windows® HID (Human Interface Device) compatible. No additional software driver is required for general operation of the monitor. Simply plug in the USB cable to the monitor and computer and power up. The computer will automatically recognize and operate the PT1520MU.

Should you desire enhanced features and calibration for 1% TPE accuracy, load 3M® MT 7.11 touch screen driver located on the enclosed CD in the “PT1520MU, LX1200, 2000, XP” link. The enhanced features include drag and drop, touch activation on lift off, enhanced touch accuracy, etc.

The following Microsoft Windows operating systems are supported by the MT 7.11 touch driver: Microsoft Windows 2000 and XP.

MT 7.11 Driver Installation Process:

1. Be sure that the USB cable is not connected to the PC.
2. Load the CD-Rom.
3. Click on the “PT1520MU, LX1200, 2000, XP” link.
4. Follow the step-by-step instructions.
5. Reconnect the USB cable to the computer prior to use.
6. Please note: if the touch screen isn't active, simply reboot your system.

Please read "Readme.txt" located in the unzipped file folder for additional information and assistance.

Planar Systems, Inc.

Customer Service

Online Support : <http://www.planar.com/support>

Email : PlanarSupport@planar.com

Tel : 1-866-PLANAR-1 (1-866-752-6271)

Hours : M-F, 8am-8pm Eastern Time (5am-5pm Pacific Time)

©2006 Planar Systems, Inc. Planar is a registered trademark of Planar Systems, Inc.

Other brands and names are the property of their respective owners.

Technical information in this document is subject to change without notice.

P/N:36.64501G011 Rev.A

020-0410-00A