



**EL320.256-FD7 320 x 256 Pixel,  
High Brightness, High Contrast Display**

**USER'S MANUAL**

[www.planar.com](http://www.planar.com)

**Revision Control**

<b>Date</b>	<b>Description</b>
November 1997	Document number PI02355 Ver 3
June 2004	Document number 020-0353-00A

# Contents

Product Profile .....	3
EL Technology.....	3
Electrical Characteristics.....	4
Connector Layout .....	4
Input Connectors and Programmable Jumpers .....	5
Connectors .....	6
Control Basics .....	6
Power Input.....	6
Display Features .....	6
Luminance Control .....	6
Two-Bits Parallel .....	6
Self-Test .....	6
Input Specifications.....	7
Timing Characteristics.....	7
Setup and Hold Timing .....	8
Operational Specifications .....	9
Environmental.....	9
Reliability.....	9
Safety.....	9
Electromagnetic Compatibility .....	9
Optical.....	10
<i>Display colour</i> .....	10
<i>Optional Filter</i> .....	10
Mechanical Characteristics.....	11
Installation and Handling.....	12
Description of Warranty .....	14
Easy to Use .....	14
Ordering Information .....	15
Support and Services.....	15

## Figures

Figure 1. EL Technology.....	3
Figure 2. Connector Layout.....	4
Figure 3. Timing Characteristics.....	7
Figure 4. Setup and Hold Timing.....	8
Figure 5. Viewing Area Characteristics .....	12
Figure 6. Mechanical Dimensions .....	13

## Tables

Table 1. Input Connectors and Programmable Jumpers.....	5
Table 2. Connectors.....	6
Table 3. Input Specifications .....	7
Table 4. Timing Characteristics. ....	8
Table 5. Setup and Hold Timing.....	8
Table 6. Environmental Characteristics.....	9
Table 7. Optical Characteristics .....	10
Table 8. Display External Dimensions.....	11
Table 9. Display Viewing Area Characteristics .....	11

---

---

## Product Profile

The EL320.256-FD7 display is a low power, rugged, electroluminescent (TFEL) display which replaces the bulky CRT in control and instrument product designs. It features an integrated DC/DC converter, and its compact dimensions save space that can allow addition of features or reduction in overall size. It is designed to function in extreme environments, and its clear display is viewable under most lighting conditions at wide viewing angles. Its ease of installation reduces system integration costs.

The EL320.256-FD7 is a 320 column by 256 row flat panel display. The digital flat panel interface is designed to match the needs of most systems.

The display requires +5 Vdc and +11 to +30 Vdc ( $V_{cc1}$ ,  $V_{cc2}$ ) power and four basic signals to operate:

1. Video Data or pixel information (VID)
2. Video Clock, pixel clock, or dot clock (VCLK)
3. Horizontal Sync (HS)
4. Vertical Sync (VS)

## EL Technology

The display consists of an electroluminescent glass panel and two mounted circuit boards with control electronics.

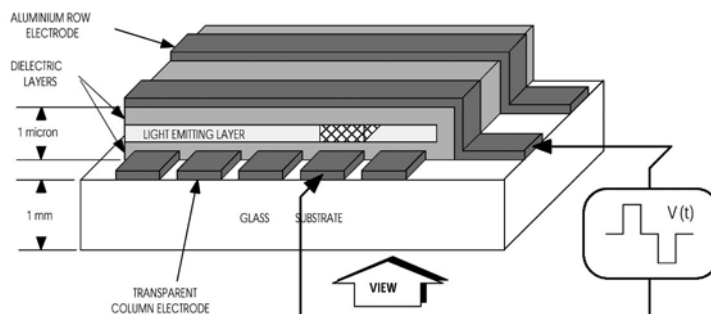

**Figure 1. EL Technology.**

The EL glass panel is a solid-state device with a thin film luminescent layer sandwiched between transparent dielectric layers and a matrix of row and column electrodes. The row electrodes, in back, are aluminium; the column electrodes, in front, are transparent. The entire thin film device is deposited on a single glass substrate. The glass panel is mounted to an electronic circuit assembly board (ECA) with an elastic spacer. The ECA's are connected to the EL glass panel with soldered lead frames. The result is a flat, compact, reliable and rugged display device.

The EL320.256-FD7 display includes a light absorbing ICE ( Integrated Contrast Enhancement) construction of the display glass. ICE construction significantly improves the luminance contrast of the display in bright ambient. The ICE also removes the halo around the lit pixels in dark ambient making the appearance of each pixel extremely crisp and clear.

In the EL320.256-F Series, the 320 column electrodes and 256 row electrodes are arranged in an X-Y formation with the intersecting areas performing as pixels. Voltage is applied to both the correct row electrode and the correct column electrode to cause a lit pixel. Operating voltages required are provided by an integral DC/DC converter.

## Electrical Characteristics

### Connector Layout

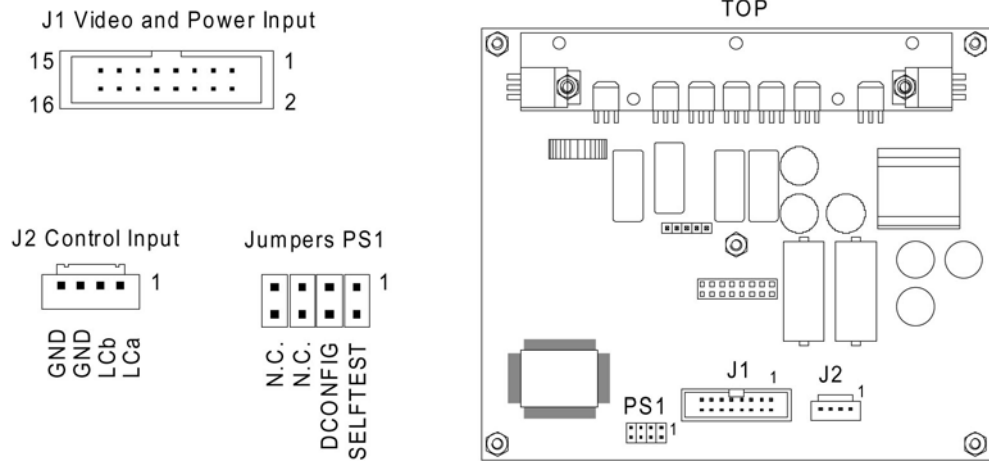

In factory default setting no jumpers are set

- REAR VIEW -

**Fig 2. Input Connectors and Programmable Jumpers.**

## Input Connectors and Programmable Jumpers

Table1. Input Connectors and Programmable Jumpers.

Pins	Signal	Symbol	Description
<b>J1(Data/power input connector)</b>			
1, 2	Voltage	Vcc2	Supply voltage (+11...30V) converted to required internal high voltages.
3, 4	Voltage	Vcc1	Supply voltage (+5 V) for the logic.
5	Enable	_ENABLE	Display operation is enabled when LOW or left disconnected.
6,8,10 12,14,16	Ground	GND	Signal and power return.
7	Two-bit data	TVID	Odd column data input for optional two bit parallel mode. See page 6.
9	Vertical Sync	VS	The vertical sync signal VS controls the vertical position of the picture. The topmost row displayed is the first HS HIGH time ending after the rising edge of the VS.
11	Horizontal Sync	HS	The horizontal sync signal HS controls the horizontal position of the picture. The last 320 pixels before the fall of HS are displayed.
13	Video Clock	VCLK	The VCLK signal shifts data present on the VID and TVID lines into the display system. VCLK is active on the rising edge.
15	Video Data	VID	Signal that supplies the pixel information to the system. Even pixel data for two pit parallel mode. See page 6.
<b>J2 (Control input)</b>			
1	Luminance	LCb	Brightness control inputs a and b. If left disconnected, luminance is at its maximum level. See brightness control on page 6.
2	Luminance	LCb	
3	Ground	GND	Signal return. Same as GND in connector J1.
4	Ground	GND	Signal return. Same as GND in connector J1.
<b>Pinstrip PS1</b>			
1	SELFTEST		When set, video data input in VID and TVID is displayed asynchronously.
2	DCONFIG		The video data is input two pixels per video clock using VID and TVID if jumper is set.

---

---

## Connectors

**Table 2. Connectors.**

J1	16-pin header Mating	ODU 511.066.003.016 or eq. ODU 517.065.003.016 or eq.
J2	4-pin header Mating Protector	Hirose DF1-4P-2.5 DSA or eq. Hirose DF1-4S-2.5 R 24 or eq. Hirose DF1-4A 1.33

## Control basics

The EL panel has 320 transparent column electrodes crossing 256 row electrodes in an X-Y fashion. Light is emitted when an AC voltage is applied at a row-column intersection. The display operation is based on the symmetric, line at a time data addressing scheme which is synchronized by the external VS, HS, and video clock input signals. The signal inputs are HCT compatible with 100  $\Omega$  series resistors.

## Power Input

The input voltages needed are the +5 V input (Vcc1) for the logic and the +11...+30V input (Vcc2) for the DC/DC converter. All high voltages required for display glass access are generated internally.

## Display Features

### Luminance Control

The luminance of the display can be adjusted from below 10% up to full brightness by a 50 k $\Omega$  external logarithmic potentiometer between LCa and LCb control inputs (J2/1 and /2). The control function is achieved by sinking a small current from LCa to LCb (when open, the voltages are at 5V and 0V respectively). If the two inputs are left disconnected, the brightness is at its maximum level.

### Two-Bits-Parallel

For reduction of data clock frequency, it is possible to input the data of two pixels per pixel clock. This feature is selected with DCONFIG jumper (PS1/2). If the jumper is set, data for even columns is input in VID and data for odd columns is input in TVID. If jumper is open, data is input normally to VID only.

### Self Test

When SELFEST jumper (PS1/1) is set, the video data at VID and TVID are displayed asynchronously without the use of any timing signals.



## Input Specifications

**Table 3. Input Specifications.**

Parameter	Symbol	Min.	Typ.	Max.	Absolute min./max.
Logic input HIGH		2V	—	V <sub>cc1</sub>	V <sub>cc1</sub> + 0.5V Abs. max.
Logic input LOW			—	0.8V	-0.5V Abs. min.
Supply voltage	V <sub>cc1</sub>	4.75V	5.0V	5.25V	6.0V Abs. max.
Supply current at 5V	I <sub>cc1</sub>	—	0.1A	0.2A	
Supply voltage	V <sub>cc2</sub>	10.8V	—	30V	33V Abs. max.
Supply current at 12V	I <sub>cc2</sub>				
@ 60 Hz		—	0.25A	0.5A*	
@ 120 Hz		—	0.5A	0.9A	
Power consumption					
@ 60 Hz		—	3.5W	6W*	
@ 120 Hz		—	6W	11W	

\* Values verified at design, not measured.

Operating conditions: Ambient temperature 25°C

**Note:** Absolute maximum ratings are those values beyond which damage to the device may occur. The minimum and maximum specifications in this Operations Manual should be met, without exception, to ensure the long-term reliability of the display. Planar does not recommend operation of the display outside these specifications.

## Timing Characteristics

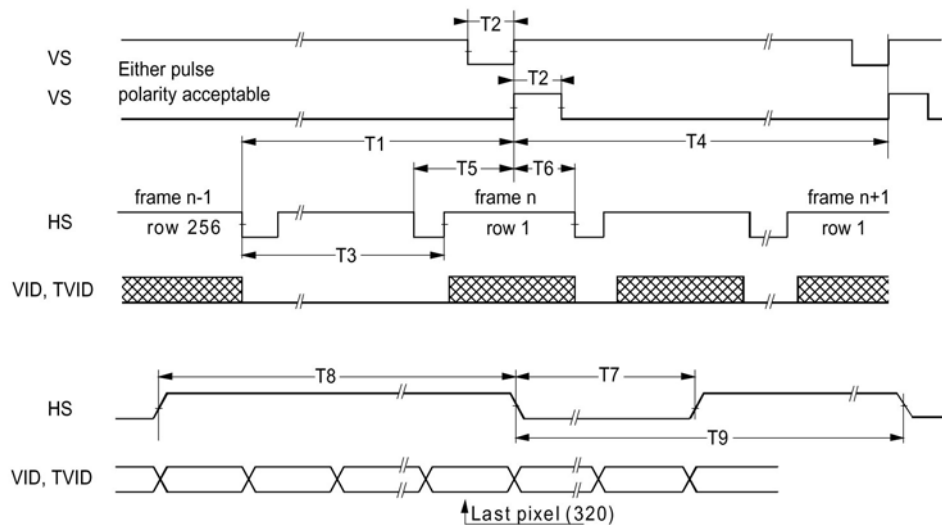

**Figure 3. Timing Characteristics**

**Table 4. Timing Characteristics.**

Description	Min	Max	Unit	Note
T1 Vertical Front Porch	60		$\mu\text{s}$	1
T2 VS HIGH/LOW time	1		tVCLK	2
T3 Vertical Blank	40		$\mu\text{s}$	
T4 Vertical Period	256		tHS	
VS frequency		120	Hz	
Description	Min	Typ	Unit	Note
T5 HS setup to VS	1		$\mu\text{s}$	3
T6 HS hold from VS	3		$\mu\text{s}$	
T7 HS Low Time	4		tVCLK	
T8 HS High Time	320	320	tVCLK	4
T9 HS period (tHS)	19		$\mu\text{s}$	

**Notes:**

1. This time is needed to display the last row and to initiate the following frame.
2. Only rising edge is used.
3. 2 tVCLK minimum
4. The number of VCLK pulses during HS high time must be even. Video clock VCLK must be kept running continuously.

## Setup and Hold Timing

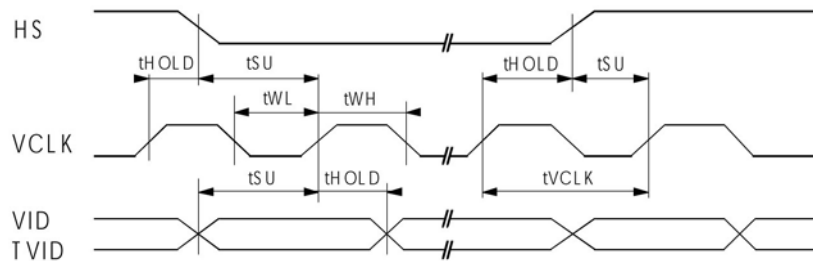

**Figure 4. Setup and Hold Timing.**

**Table 5. Setup and Hold Timing.**

Symbol	Description	Min	Max
tSU	HS, VID, TVID setup to VCLK	8ns	
tHOLD	HS, VID, TVID hold from VCLK	8ns	
tWL	VCLK low width	16ns	
tWH	VCLK high width	16ns	
tVCLK	VCLK period	40ns	
	VCLK frequency		25 MHz

---

---

# Operational Specifications

## Environmental

**Table 6. Environmental Characteristics.**

<b>Temperature</b>	
Operating	-25...+65°C
Non-operating	-40...+85°C
Operating Survival	-40...+70°C (no permanent damage)
<b>Humidity</b>	
Relative Humidity	+40°C, 93% RH, Operating (IEC 68-2-3)
Damp Heat	+25...+55°C, 95% RH, Non operating (IEC 68-2-30)
<b>Altitude</b>	
	15,000 m (50,000 ft.) above sea level Standard IEC 68-2-13
<b>Vibration</b>	
	20...500 Hz ASD level 0.05 g <sup>2</sup> /Hz 30 min each axis Standard IEC 68-2-36, Random Vibration, Test Fdb
<b>Shock</b>	
Magnitude	100 g
Duration	4 ms (half sine wave)
Number of shocks	18 (3 on each of the 6 surfaces) IEC 68-2-27, test Ea

## Reliability

MTBF > 50,000 h @ 25°C, @ 120 Hz

## Safety

The display will not inhibit the end product from obtaining any of the following certifications: UL544, IEC 950.

## Electromagnetic Compatibility

The display is capable of operating in an end product that complies with: EN55022 Class B, FCC Part 15J Class B.

---

---

## Optical

Determined at 25°C ambient.

### *Display colour*

Wide band amber (ZnS:Mn) Peak wavelength 580nm typ.

**Table 7. Optical Characteristics.**

---

<b>Areal Luminance</b>		
On Luminance	28 cd/m <sup>2</sup> (8.2 fL) min @ 60Hz	
	55 cd/m <sup>2</sup> (16 fL) min @ 120Hz	
Measured at the center and the four corners of the screen.		
<hr/>		
<b>Luminance Non-uniformity</b>		
Maximum	30%	= (1 – min. luminance/max luminance) x 100.
<hr/>		
<b>Luminance Variation (Time)</b>		
Maximum	20%	10,000 h @ 25°C
<hr/>		
<b>Luminance Variation (Temperature)</b>		
Maximum	15%	over specified temperature ranges.
<hr/>		
<b>Luminance Contrast Ratio</b>		
Minimum	20:1	@ 60HZ, @ 500lx
	3:1	@ 60HZ, @ 4500lx
	36:1	@ 120HZ, @ 500lx
	3:1	@ 120HZ, @ 9000lx
<hr/>		
<b>Viewing Angle</b>		
Minimum	160°	
<hr/>		

Illuminance	Classification
1 ... 10 lx	dark
10 ... 100 lx	dim
100 ... 1000 lx	office
1000 ... 10000 lx	bright
10000 ... 100000 lx	sunlight

### *Optional Filter*

The luminance contrast of EL320.256–FD7 is sufficient for operation without any contrast enhancement. An anti-reflective coating or protecting sheet with anti-reflective treatment is recommended. For best overall performance in high ambient luminance levels, a circular polarizing filter with anti-reflecting coating or etch is recommended. This filter will still lower the reflections from the display background and improve the contrast ratio. Contact Planar for details.

---

---

## Mechanical Characteristics

Figs. 6 shows the mechanical dimensions of a EL320.256-FD7 display unit.

**Table 8. Display External Dimensions.**

<b>Height</b>	110 mm	4.33 in.
<b>Width</b>	130 mm	5.12 in.
<b>Depth</b>	33.0 mm	1.30 in.
<b>Weight</b>	310 g max.	10.9 oz. max

The EL320.256–FD7 is mechanically compatible with existing Planar MD320.256 and EL320.256 displays

**Table 9. Display Viewing Area Characteristics.**

<b>Active Area</b>			
millimeters (inches)	height	76.7 (3.02)	
	width	95.9 (3.77)	
<b>Pixel Pitch</b>			
millimeters (inches)	height	0.30 (0.012)	
	width	0.30 (0.012)	
<b>Pixel Size</b>			
millimeters (inches)	height	0.24 (0.009)	
	width	0.24 (0.009)	
<b>Pixel fill factor</b>		64%	
<b>Pixel Matrix</b>		320 horizontal by 256 vertical	

---

**CAUTION:** The ambient temperature of the display should not be allowed to exceed the environmental specifications (see page 9). In most applications, an air gap of min5 mm is recommended (see mechanical drawings). Some applications may require, however, a larger air gap or cooling of the display unit in the system. Note that this may slightly increase the total depth of the design.

---

---

**WARNING:** The product generates potentially dangerous voltages capable of causing personal injury (high voltage pulses up to 195 Vac). Do not touch the display electronics during operation!

---

---

**ELECTROSTATIC CAUTION:** The Planar display uses CMOS and power MOS-FET devices. These components are electrostatic sensitive. Unpack, assemble and examine this assembly in a static-controlled area only. When shipping use packing materials designed for protection of electrostatic-sensitive components

---

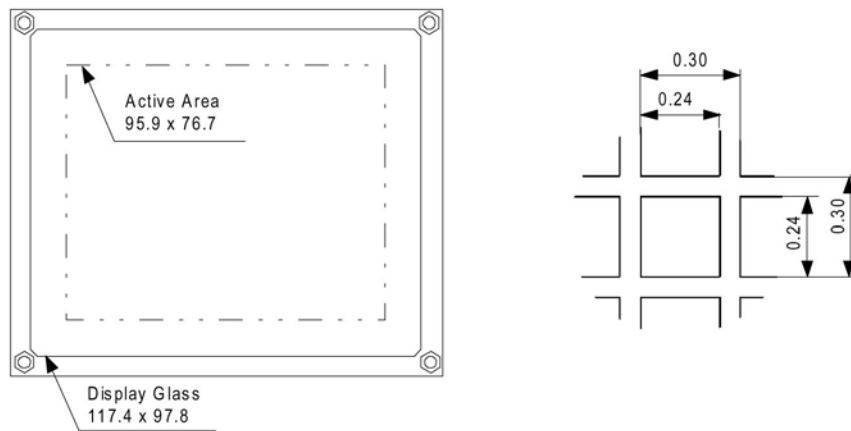

*Fig 5. Viewing Area Characteristics in mm.*

## Installation and Handling

EL320.256–FD7 should be mounted using the four M3 corner standoffs. It is recommended to use also the center nut in the mounting if the vibration or shock stress is severe.

Before touching the display, necessary precaution must be taken to prevent application of static charges on the display from the operator or tools.

The display is made of glass material and should be handled with proper care. Do not drop the display or allow hard objects to strike its surface.

---

**NOTE:** For trouble-free data transfer a maximum cable length of 300 mm (12 in.) from data transmitter to display input connector is recommended. If longer cables up to 2 m (80 in.) length are needed, a serial resistor of appr. 100  $\Omega$  could be placed at each of the four signal line outputs of the transmitter in order to lower signal reflections.

---

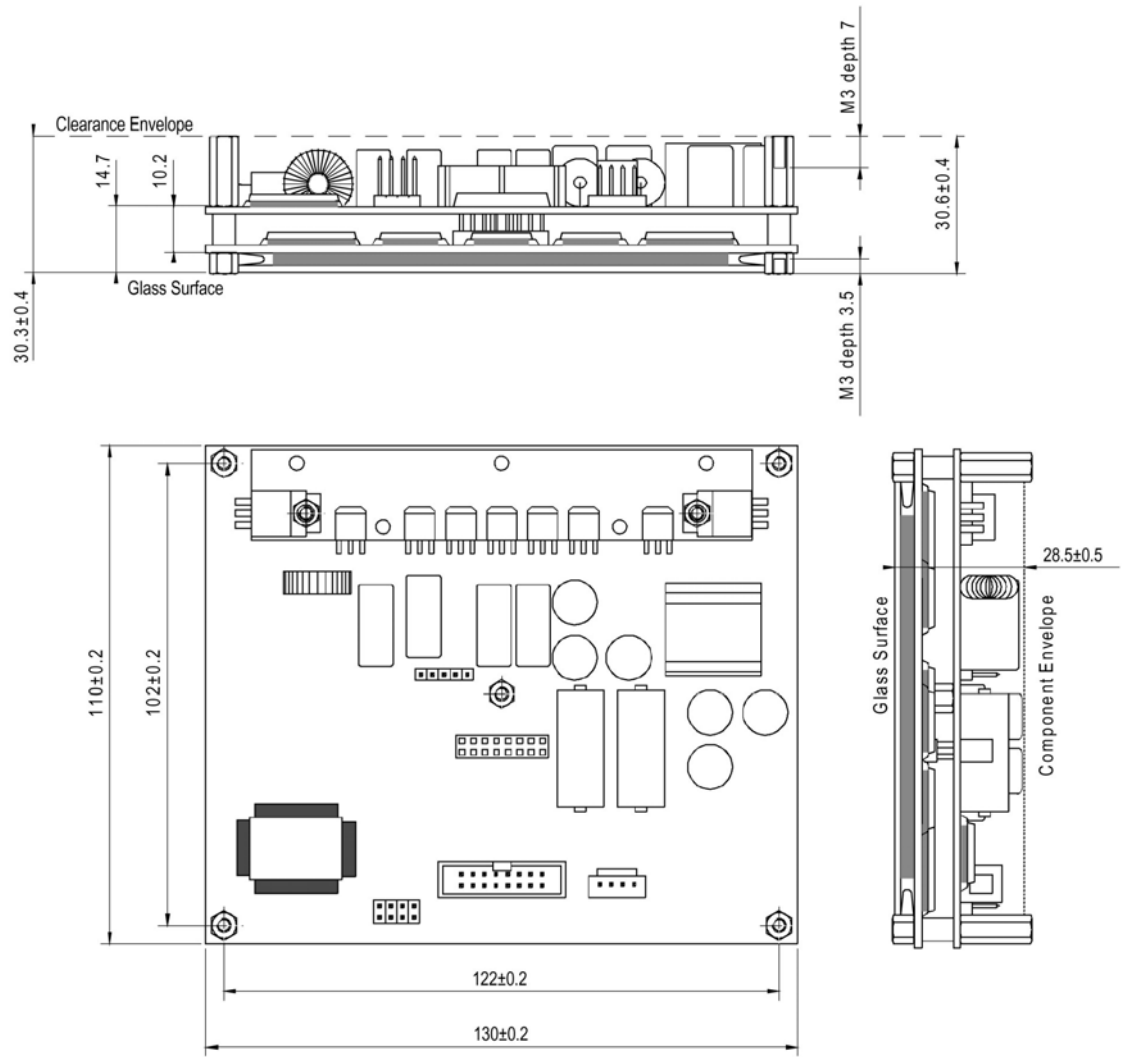

PI02345 5.9.1994

**Fig 6. Mechanical dimensions in mm.**

---

## Description of Warranty

Seller warrants that the Goods will conform to published specifications and be free from defects in material for 12 months from delivery. To the extent that Goods incorporate third-party-owned software, Seller shall pass on Seller's licensor's warranty to Buyer subject to the terms and conditions of Seller's license.

Warranty repairs shall be warranted for the remainder of the original warranty period. Buyer shall report defect claims in writing to Seller immediately upon discovery, and in any event, within the warranty period. Buyer must return Goods to Seller within 30 days of Seller's receipt of a warranty claim notice and only after receiving Seller's Return Goods Authorization. Seller shall, at its sole option, repair or replace the Goods.

If Goods were repaired, altered or modified by persons other than Seller, this warranty is void. Conditions resulting from normal wear and tear and Buyer's failure to properly store, install, operate, handle or maintain the Goods are not within this warranty. Repair or replacement of Goods is Seller's sole obligation and Buyer's exclusive remedy for all claims of defects. If that remedy is adjudicated insufficient, Seller shall refund Buyer's paid price for the Goods and have no other liability to Buyer.

All warranty repairs must be performed at Seller's authorized service center using parts approved by Seller. Buyer shall pay costs of sending Goods to Seller on a warranty claim and Seller shall pay costs of returning Goods to Buyer. The turnaround time on repairs will usually be 30 working days or less. Seller accepts no added liability for additional days for repair or replacement.

If Seller offers technical support relating to the Goods, such support shall neither modify the warranty nor create an obligation of Seller. Buyer is not relying on Seller's skill or judgment to select Goods for Buyer's purposes. Seller's software, if included with Goods, is sold as is, and this warranty is inapplicable to such software.

SELLER DISCLAIMS ALL OTHER WARRANTIES, EXPRESS OR IMPLIED, INCLUDING BUT NOT LIMITED TO, IMPLIED WARRANTIES OF MERCHANTABILITY AND FITNESS FOR A PARTICULAR PURPOSE.

## Easy to Use

There are many options available which make Planar flat panel displays easy to use, easy to interface, and easy to package. Call Planar for complete information.



---

---

## Ordering Information

Product	Part Number	Description
EL320.256-FD7	996-5089-00	EL320.256 ICE high-bright display, Op. temp -25 - +65° C
EL320.256-FD7 AG	996-5089-01	EL320.256-FD7 with optically bonded anti-glare film

Design and specifications are subject to change without notice.

## Support and Service

Planar is a U.S. company based in Beaverton, Oregon and Espoo, Finland, with a world-wide sales distribution network. Full application engineering support and service are available to make the integration of Planar displays as simple and quick as possible for our customers.

**RMA Procedure:** Applying for a Returned Material Authorization number, please contact Planar Systems, Inc., with the model number(s) and original purchase order number(s). When returning goods for repair, please include a brief description of the problem, and be sure to mark the outside of the shipping container with the RMA number.

---

---

## **Planar Systems, Inc.**

Customer Service

**24x7 Online Technical Support:** <http://www.planar.com/support>

### **Americas Support**

1195 NW Compton Drive

Beaverton, OR 97006-1992

**Tel:** 1-866-PLANAR1 (866) 752-6271

**Hours:** M-F, 5am - 5pm Pacific Time

### **Europe and Asia-Pacific Support**

Olarinluoma 9 P.O. Box 46

FIN-02201 Espoo, Finland

**Tel:** +358-9-420-01

**Hours:** M-F, 7:00am - 4pm CET

© 2004 **Planar Systems, Inc. 06/04** Planar is a registered trademark of Planar Systems, Inc.

**ICE, ICEBrite, and ICEPlus** are trademarks of Planar Systems, Inc.

Other brands and names are the property of their respective owners.

Technical information in this document is subject to change without notice.

**020-0353-00A**